



US009140709B2

(12) **United States Patent**
Spinke et al.

(10) **Patent No.:** **US 9,140,709 B2**
(45) **Date of Patent:** ***Sep. 22, 2015**

(54) **ANALYTICAL SANDWICH TEST FOR DETERMINING NT-PROBNP**

33/543 (2013.01); *G01N 33/558* (2013.01);
C07K 2317/34 (2013.01); *G01N 2333/58*
(2013.01)

(75) Inventors: **Juergen Spinke**, Lorsch (DE); **Alfons Nichtl**, Hohenpeissenberg (DE); **Volker Klemt**, Weilheim (DE); **Klaus Hallermayer**, Feldafing (DE); **Michael Grol**, Feldafing (DE); **Anneliese Borgya**, Seeshaupt (DE); **Andreas Gallusser**, Penzberg (DE)

(58) **Field of Classification Search**

CPC *C07K 16/26*; *C07K 2317/34*; *G01N 33/5302*; *G01N 33/543*; *G01N 33/558*; *G01N 33/74*; *G01N 2333/58*

USPC 422/55, 56, 57, 58; 435/7.1, 7.5, 7.92, 435/7.94, 7.95, 70.21, 452, 336, 287.2, 435/287.9; 436/514, 518, 524, 525, 528, 436/531, 548, 169, 810, 811; 530/324, 530/388.24, 389.2, 391.1

See application file for complete search history.

(73) Assignee: **Roche Diagnostics Operations, Inc.**, Indianapolis, IN (US)

(*) Notice: Subject to any disclaimer, the term of this patent is extended or adjusted under 35 U.S.C. 154(b) by 853 days.

This patent is subject to a terminal disclaimer.

(56) **References Cited**

U.S. PATENT DOCUMENTS

4,861,711 A 8/1989 Friesen et al.
5,073,484 A 12/1991 Swanson et al.

(Continued)

FOREIGN PATENT DOCUMENTS

AU 758562 * 8/2000
EP 0 291 194 A1 11/1988

(Continued)

OTHER PUBLICATIONS

Karl, et al., *Development of a Novel, N-terminal-pro-BNP (NT-proBNP) assay with low detection limit*, Scan. J. Clin. Lab. Invest 59 (Suppl 230):177-181 (1999).

(Continued)

Primary Examiner — Gail R Gabel

Assistant Examiner — James L Grun

(74) *Attorney, Agent, or Firm* — Stinson Leonard Street LLP

(21) Appl. No.: **12/354,410**

(22) Filed: **Jan. 15, 2009**

(65) **Prior Publication Data**

US 2009/0123947 A1 May 14, 2009

Related U.S. Application Data

(63) Continuation of application No. 10/994,851, filed on Nov. 22, 2004, now Pat. No. 7,507,550.

(30) **Foreign Application Priority Data**

Nov. 28, 2003 (DE) 103 55 731

(51) **Int. Cl.**

G01N 33/74 (2006.01)
G01N 33/543 (2006.01)

(Continued)

(52) **U.S. Cl.**

CPC *G01N 33/74* (2013.01); *C07K 16/26* (2013.01); *G01N 33/5302* (2013.01); *G01N*

(57) **ABSTRACT**

The present invention concerns an immunological test for determining NT-proBNP comprising at least two antibodies to NT-proBNP, wherein at least one of the antibodies to NT-proBNP is a monoclonal antibody. The epitopes recognized by the antibodies can slightly overlap.

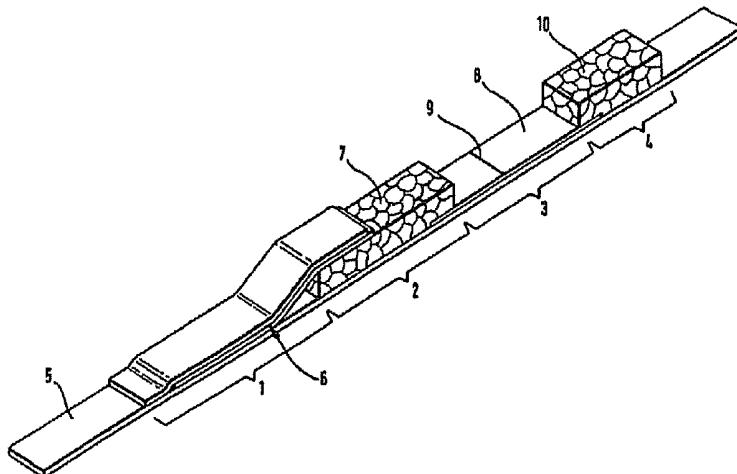

17 Claims, 5 Drawing Sheets

- (51) **Int. Cl.**
G01N 33/558 (2006.01)
C07K 16/26 (2006.01)
G01N 33/53 (2006.01)

(56) **References Cited**

U.S. PATENT DOCUMENTS

5,141,850	A	8/1992	Cole et al.	
5,458,852	A	10/1995	Buechler	
5,591,645	A	1/1997	Rosenstein	
5,786,163	A	7/1998	Hall	
6,117,644	A	9/2000	DeBold	
6,136,963	A *	10/2000	Chandrashekar	536/23.1
6,461,828	B1	10/2002	Stanton et al.	
6,506,612	B2	1/2003	Kang et al.	
6,833,275	B1	12/2004	Nichti	
RE38,688	E *	1/2005	Friesen et al.	436/518
7,109,023	B2 *	9/2006	Kang et al.	435/287.2
7,264,938	B2 *	9/2007	Borgya et al.	435/7.1
7,507,550	B2 *	3/2009	Spinke et al.	435/7.5
7,527,939	B2 *	5/2009	Davey et al.	435/7.94
2004/0096920	A1	5/2004	Davey et al.	

FOREIGN PATENT DOCUMENTS

WO	WO 93/024531	A1	12/1993
WO	WO 97/06439	A1	2/1997
WO	WO 00/35951		6/2000
WO	WO 00/45176	A2	8/2000
WO	WO 02/083913	A1	10/2002
WO	WO 03/087819	A1	10/2003
WO	WO 2004/046194	A	6/2004
WO	WO 2004/099252	A1	11/2004
WO	WO 2004/099253	A1	11/2004

OTHER PUBLICATIONS

Omland, et al., *N-terminal pro-B-type Natriuretic peptide and long-term mortality in acute coronary syndromes*, Circulation 106:2913-2319 (2002).

Shimizu, Hiroyuki, et al., *Characterization of molecular forms of probrain natriuretic peptide in human plasma*, Clinica Chimica Acta 334:233-239 (2003).

Hughes, et al., *An immunoluminometric assay for N-terminal pro-brain natriuretic peptide: development of a test for left ventricular dysfunction*, Clinical Science, 96:373-380 (1999).

* cited by examiner

Fig. 1

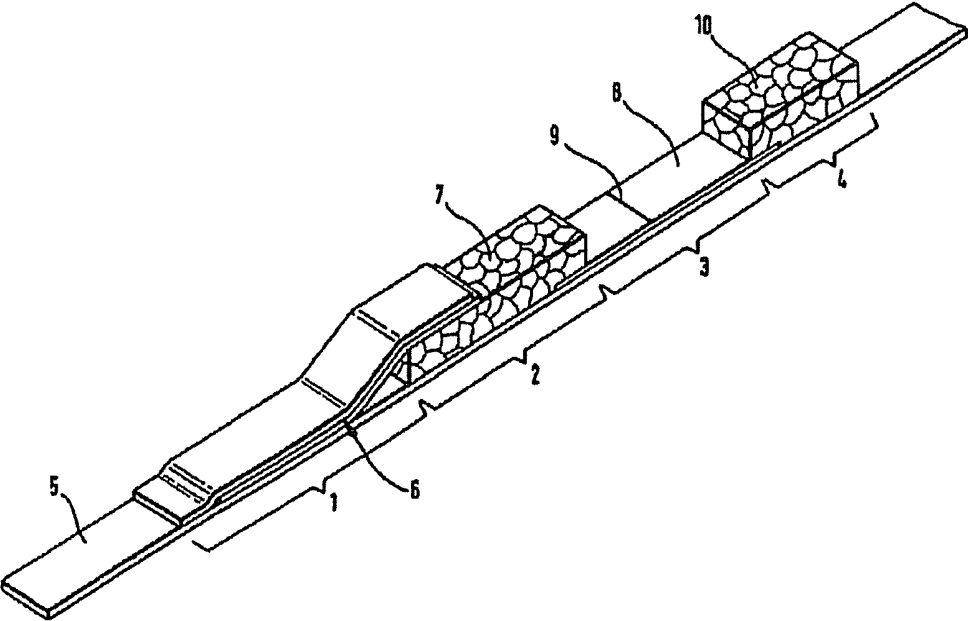

Fig. 2

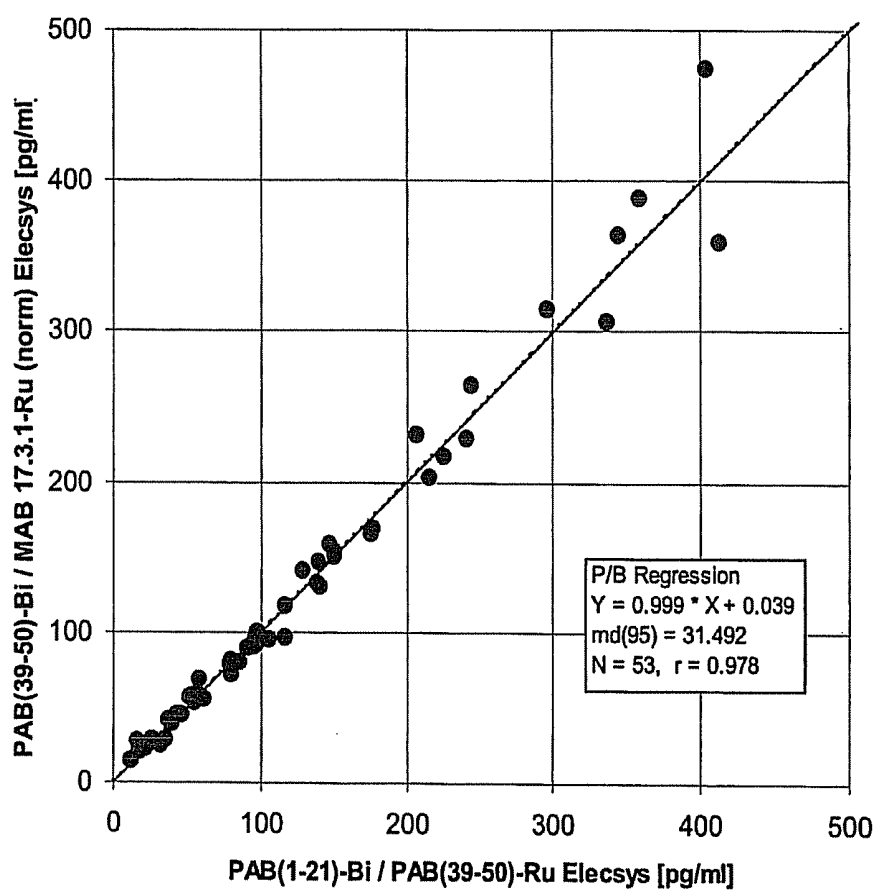

Fig. 3

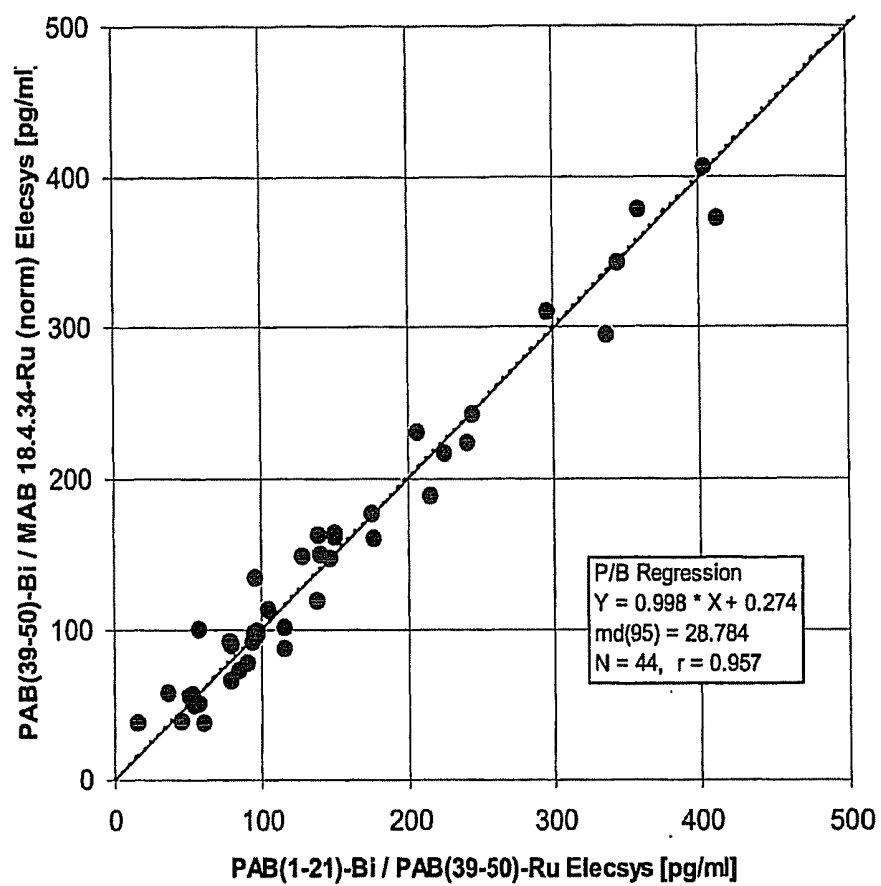

Fig. 4

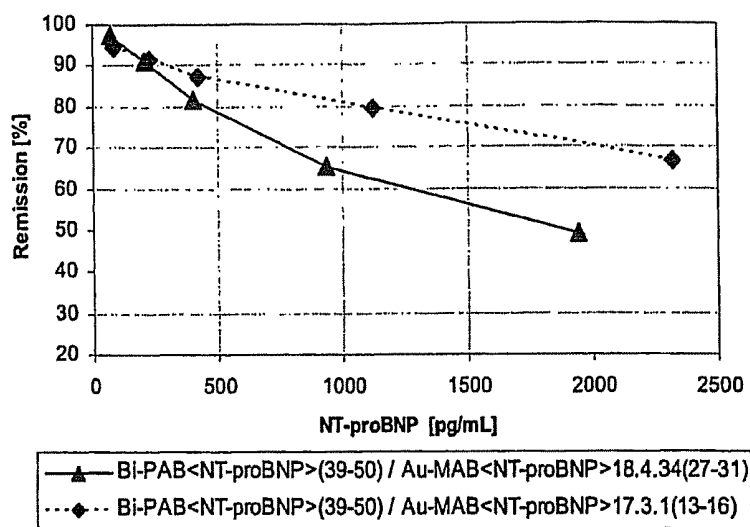
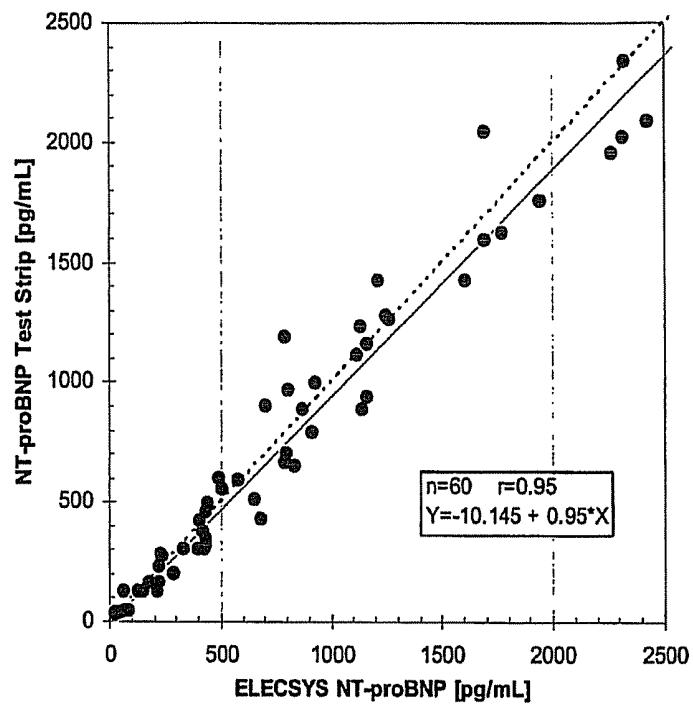

Fig. 5



ANALYTICAL SANDWICH TEST FOR DETERMINING NT-PROBNP

CROSS-REFERENCE TO RELATED APPLICATION

This application is a continuation of U.S. patent application Ser. No. 10/994,851, filed Nov. 22, 2004, now U.S. Pat. No. 7,507,550. U.S. Ser. No. 10/994,851 claims the benefit of German Patent Application Serial No. DE 103 55 731.8.

BACKGROUND OF THE INVENTION

The present invention concerns an analytical sandwich test, in particular a test element and in particular in the form of an immunochromatographic test strip using the sandwich principle to determine N-terminal pro-brain natriuretic peptide (NT-proBNP).

NT-proBNP is a very promising marker for the diagnosis and management of heart failure. At present, the only NT-proBNP test that is available on the in-vitro diagnostic market is the fully automated Elecsys® NT-proBNP test from Roche Diagnostics which is based on a sandwich reaction with electrochemiluminescence detection. This test is designed to be used in large central laboratories and in addition to liquid reagents that have to be exactly dosed, requires a relatively complex instrument to dose the liquids and to detect the luminescence signal in order to carry out the test. A simple to use, rapid test for NT-proBNP which if needed can be evaluated visually without an evaluation instrument is presently not on the market.

In patients with acute respiratory distress it is advantageous to carry out a NT-proBNP determination as rapidly as possible in order to exclude or diagnose heart failure as a cause of the dyspnoea and to initiate appropriate treatment. Since the Elecsys® NT-proBNP test can only be carried out in a central laboratory, it is difficult to rapidly determine NT-proBNP outside the routine times. Hence, it would be particularly advantageous for the emergency ward if a rapid test were available which could be carried out directly in the emergency ward outside of routine times. This rapid test should, however, ensure the same reference ranges and cut-offs as the reference method in the central laboratory (Elecsys® NT-proBNP) in order to enable a good comparability of the results independently of the type of test that is actually carried out.

The polyclonal antibodies (PAB) used in the Elecsys® NT-proBNP test recognize a very special fraction of NT-proBNP ("native" NT-proBNP; see International Patent Application PCT/EP2004/005091 dated May 12, 2004 from Klemm et al.; according to this the test recognizes the epitopes of NT-proBNP comprising the amino acids 1-21 (AA 1-21) and 39-50 (AA 39-50)). However, it has turned out that these polyclonal antibodies are unsuitable for NT-proBNP rapid tests that use particulate labels such as colloidal gold as a label since they exhibit a high undesired variability in the signal generation due to physico-chemical interactions with the components of the rapid test (such as the support materials, matrices, etc.). This results in considerable fluctuations in the quality of the test from batch to batch.

SUMMARY OF THE INVENTION

It is against the above background that the present invention provides certain unobvious advantages and advancements over the prior art. In particular, the inventors have recognized a need for improvements in rapid analytical tests

for determining NT-proBNP, which can be reproducibly manufactured and has a good correlation to the laboratory method.

In various embodiments of the invention, the following combinations of antibodies are used:

Combination I

- i. a monoclonal antibody directed against an epitope of NT-proBNP comprising amino acids of human NT-proBNP selected from the group consisting of: 1-21, 13-16, 22-38, 51-76 and 64-67;
- ii. a polyclonal antibody directed against an epitope of NT-proBNP comprising amino acids 39-50;

Combination II

- i. a monoclonal antibody directed against an epitope of NT-proBNP comprising amino acids of human NT-proBNP selected from the group consisting of: 1-21, 22-37, and 43-76;
- ii. a polyclonal antibody directed against an epitope of NT-proBNP comprising amino acids 38-42;

Combination III

- i. a monoclonal antibody directed against an epitope of NT-proBNP comprising amino acids of human NT-proBNP selected from the group consisting of: 1-21, 22-43, and 51-76;
- ii. a polyclonal antibody directed against an epitope of NT-proBNP comprising amino acids 44-50;

Combination IV

- i. a monoclonal antibody directed against an epitope of NT-proBNP comprising amino acids 27-31;
- ii. a polyclonal antibody directed against an epitope of NT-proBNP selected from the group consisting of: 39-50, 38-42, and 44-50;

Combination V

- i. a monoclonal antibody directed against an epitope of NT-proBNP comprising amino acids 13-16;
- ii. a polyclonal antibody directed against an epitope of NT-proBNP selected from the group consisting of: 39-50, 38-42, and 44-50;

Combination VI

- i. a monoclonal antibody directed against an epitope of NT-proBNP comprising amino acids 27-31 of human NT-proBNP;
- ii. a monoclonal antibody directed against an epitope of NT-proBNP comprising amino acids 38-42 of human NT-proBNP.

In accordance with one embodiment of the present invention, an immunological test for determining NT-proBNP is provided comprising at least two antibodies to NT-proBNP, wherein at least one of the antibodies to NT-proBNP is a monoclonal antibody. One of these antibodies is directed at least against parts of the epitope of NT-proBNP comprising the amino acids 38 to 50. In addition, one of these antibodies is directed at least against parts of the epitope of NT-proBNP comprising the amino acids 1 to 37 or 43 to 76. The epitope recognized by the antibodies can slightly overlap.

These and other features and advantages of the present invention will be more fully understood from the following detailed description of the invention taken together with the accompanying claims. It is noted that the scope of the claims is defined by the recitations therein and not by the specific discussion of features and advantages set forth in the present description.

BRIEF DESCRIPTION OF THE DRAWINGS

The following detailed description of the embodiments of the present invention can be best understood when read in

conjunction with the following drawings, where like structure is indicated with like reference numerals and in which:

FIG. 1 shows a diagram of a rapid test device according to one embodiment of the present invention in the form of an immunochromatographic test strip;

FIG. 2 shows the correlation of the antibody combination MAB 17.3.1 (13-16)/PAB (39-50) in the Elecsys® wet test format with the Elecsys® reference method PAB (1-21)/PAB (39-50);

FIG. 3 shows the correlation of the antibody combination MAB 18.4.34 (27-31)/PAB (39-50) in the Elecsys® wet test format with the Elecsys® reference method PAB (1-21)/PAB (39-50);

FIG. 4 shows function curves of NT-proBNP test strips according to Example 1 with different antibody combinations; and

FIG. 5 shows the correlation of an NT-proBNP test strip with the antibody combination: Au-MAB 18.4.34 (27-31)/Bi-PAB (39-50) to the Elecsys® NT-proBNP test kit.

Skilled artisans appreciate that elements in the figures are illustrated for simplicity and clarity and have not necessarily been drawn to scale. For example, the dimensions of some of the elements in the figures may be exaggerated relative to other elements to help improve understanding of the embodiment(s) of the present invention.

DETAILED DESCRIPTION OF EMBODIMENTS OF THE INVENTION

The inventive solution for producing an immunological test in a sandwich format in accordance with one embodiment of the present invention and, in particular, a rapid test which correlates well with the Elecsys® reference method uses a combination of antibodies comprising at least two antibodies to NT-proBNP, where at least one antibody is a monoclonal antibody (MAB). Another antibody of the sandwich test according to an embodiment of the present invention can either also be a MAB or a polyclonal antibody (PAB). In this connection one of these antibodies (abbreviated AB) is directed at least against parts of the epitope of NT-proBNP comprising amino acids 38 to 50 (in the following also abbreviated to AB (38-50) or MAB (38-50) or PAB (38-50)). At least one additional antibody is directed at least against parts of the epitope of NT-proBNP comprising amino acids 1 to 37 or 43 to 76 (in the following abbreviated to AB (1-37) or AB (43-76) or MAB (1-37) or MAB (43-76) or PAB (1-37) or PAB (43-76)). The epitopes recognized by the antibodies can slightly overlap, typically by less than 5 amino acids, more typically by less than 2 amino acids.

A combination of antibodies is typical comprising at least one polyclonal antibody (PAB) and one monoclonal antibody (MAB) (so-called PAB/MAB combination) to NT-proBNP.

The term PAB (X-Y) as used herein means a polyclonal antibody which is directed against the epitope of NT-proBNP comprising the amino acids X to Y. MAB (X-Y) is a corresponding monoclonal antibody. AB (X-Y) generally denotes an antibody (e.g., PAB or MAB) which is directed against the epitope of NT-proBNP comprising the amino acids X to Y.

MAB a.b.c. (X-Y) is a monoclonal antibody directed against the epitope of NT-proBNP comprising the amino acids X to Y which is obtained from a deposited cell line a.b.c.

In order to guarantee a reproducible quality of the antibody-label conjugate, the MAB is typically immobilized on a particulate label, in particular on a gold label. Other suitable particulate labels are for example coloured latices, other metal sol labels, polymer labels or semiconductor nanocrystals (so-called quantum dots). The MAB-label conjugate is

typically provided on the rapid test device in such a manner that it can be detached from it by the sample liquid, for example by impregnating suitable support materials such as fleeces, membranes, etc. It is, however, also possible to add the MAB-label conjugate as a solution to the rapid test.

The PAB which is typically obtained by immunizing mammals, in particular sheep, goats or rabbits, is typically provided in the rapid test as a biotin derivative and can be bound to an avidin or streptavidin detection line. However, it also possible to directly immobilize the PAB in the rapid test device, for example in the form of a detection line on a suitable chromatography membrane.

According to an embodiment of the present invention, it is also possible although less typical, to use the labelled AB, in particular the labelled MAB, and the second antibody, in particular the second MAB or PAB in solution or in solutions for the rapid test. A binding partner which can capture the appropriately labelled AB is then located in a detection zone on the test device and thus binds the sandwich complex comprising first antibody, analyte and second antibody to a solid phase of the rapid test.

The MAB used according to an embodiment of the present invention does not necessarily have to recognize the epitope (AA 1-21) that is detected in the reference system (Elecsys® test) in order to ensure good correlation with the reference test: the antibody combinations and, in particular, the MAB/PAB combinations MAB 17.3.1 (13-16)/PAB (39-50) and MAB 18.4.34 (27-31)/PAB (39-50) correlate well with the Elecsys® reference system which uses polyclonal antibodies to the epitopes AA 1-21 and AA 39-50 of NT-proBNP (PAB (1-21) and PAB (39-50)). Other useful combinations include MAB 17.3.1 (13-16)/PAB (38-42) and MAB 18.4.34 (27-31)/PAB (38-42).

The polyclonal antibodies such as PAB (1-21) and PAB (39-50) can be obtained, characterized and identified by methods known to a person skilled in the art especially in analogy to example 2 of WO 00/45176.

The monoclonal antibodies such as MAB (38-42) and MAB (44-50) can be obtained, characterized and identified by methods known to a person skilled in the art especially in analogy to example 3 of WO 00/45176 or example 3 of the International Patent Application PCT/EP2004/005091 dated May 12, 2004 (Klemm et al.).

The antibodies are labelled for example with gold or other labels, biotin, etc. by methods known to a person skilled in the art (cf., also example 2 in WO 00/45176 and example 2 of the International Patent Application PCT/EP2004/005091 dated May 12, 2004 by Klemm et al.). Labelling with gold is, for example, described in detail in EP-A 0 898 170.

In particular, the typical monoclonal antibodies MAB 17.3.1 (13-16), MAB 16.1.39 (38-42), MAB 18.29.23 (64-67) and MAB 18.4.34 (27-31) can be obtained according to example 3 of the International Patent Application PCT/EP2004/005091 dated May 12, 2004 by Klemm et al. Corresponding cell lines are deposited at the Deutsche Sammlung von Mikroorganismen und Zellkulturen GmbH (DSMZ), Mascheroder Weg 1B, D-38124 Braunschweig, Germany (accession numbers of the depository and date of deposition: DSM ACC2591 (7th May 2003) for MAB 17.3.1 (13-16); DSM ACC2590 (7th May 2003) for MAB 16.1.39 (38-42); DSM ACC2593 (7th May 2003) for MAB 18.29.23 (64-67) and DSM ACC2592 (7th May 2003) for MAB 18.4.34 (27-31).

The combination of MAB 18.4.34 (27-31)/PAB (39-50) results in a relatively good correlation with the reference test as does the combination MAB 17.3.1 (13-16)/PAB (39-50) (see also example 2).

In addition the combination MAB 18.4.34 (27-31)/PAB (39-50) proved to be particularly advantageous for the test according to an embodiment of the present invention: this combination enabled a function curve to be adapted that is particularly suitable for rapid tests (see example 3). In comparison, the combination MAB 17.3.1 (13-16)/PAB (39-50) exhibited a poorer test sensitivity.

In order that the invention may be more readily understood, reference is made to the following examples, which are intended to illustrate the invention, but not limit the scope thereof.

EXAMPLES

Example 1

Preparation of a Test Device for Determining NT-proBNP from Whole Blood

The test device (FIG. 1) consists of a support material (5) on which a sample application zone (1), an erythrocyte separation zone (2), a detection zone (3) and a suction zone (4) are mounted. A sample application matrix (6) which partially overlaps an erythrocyte separation zone (7) is located in the sample application zone (1). The erythrocyte separation matrix (7) in turn slightly overlaps the detection matrix (8) (detection zone) on which an immobilized substance is applied in the form of a line (9). A suction matrix (10) slightly overlaps the detection matrix (8). All reagents that are necessary to form a complex with the analyte to be detected are accommodated in the sample application matrix (6). For example, the sample application zone can be composed of two fleeces on top of one another where the first ("gold fleece") is impregnated with a gold-labelled antibody to NT-proBNP (MAB 18.4.34 (27-31)) and the second fleece ("biotin fleece") contains a biotinylated antibody to NT-proBNP (PAB (39-50)). A line (9) made of streptavidin is applied within the detection zone.

A polyester foil (Pütz) of 350 µm thickness is used as the support layer (5). A polyester fleece (Roche Diagnostics) of 360 µm thickness is used as the "gold fleece" or "biotin fleece" of the sample application matrix (6). A glass fibre fleece (Roche Diagnostics) of 1.8 mm thickness is used as an erythrocyte separation matrix (7). A nitrocellulose membrane (Sartorius) of 140 µm thickness is used as the detection matrix (8). A glass fibre fleece (Roche Diagnostics) of 1.8 mm thickness is used as the suction matrix (10). The individual components (6, 7, 8, 10) are glued slightly overlapping on the support layer (5) by means of hot-melt adhesive as shown in FIG. 1.

The impregnation formulation of the "gold and biotin fleeces" is:

"biotin fleece":	100 mM Hepes pH 7.4, 0.1% Tween ®, 20 µg/ml biotinylated PAB (39-50)
"gold fleece":	100 mM Hepes pH 7.4, OD 4 MAB 18.4.34 (27-31) gold conjugate

Example 2

Correlation of the Epitope/Antibody Combination MAB 17.3.1 (13-16)/PAB (39-50) and MAB 18.4.34 (27-31)/PAB (39-50) in the Elecsys® Format to the Elecsys® NT-proBNP Test Kit (cf., FIGS. 2 and 3)

The correlation of the MAB/PAB combinations MAB 17.3.1 (13-16)/PAB (39-50) and MAB 18.4.34 (27-31)/PAB

(39-50) to the Elecsys® test kit (PAB (1-21)/PAB (30-50)) was examined in an electrochemiluminescence immunoassay on an Elecsys® 2010 (Roche Diagnostics). For this the PAB (39-50) was used as a biotinylated capture reagent and ruthenylated F(ab')₂ fragments of the MABs were used as the detection reagent. 20 µl sample or standard material was in each case incubated with 75 µl of the two antibody reagents for 9 minutes at 37° C. Afterwards, 35 µl streptavidin-coated magnetic polystyrene particles were added and it was incubated for a further 9 minutes at room temperature. The electroluminescence signal of an aliquot of the incubation solution was measured routinely on the Elecsys® 2010 and converted into a concentration signal by means of a standard curve.

Clinical samples from patients with cardiac failure were now measured with the two MAB/PAB test variants and the Elecsys® kit. The results are shown in FIGS. 2 and 3. A very good correlation to the Elecsys® kit ($r=0.978$ and $r=0.957$) was obtained with both MAB/PAB variants.

Example 3

Function Curve of an NT-proBNP Test Strip with Two Different MAB/PAB Combinations

An NT-proBNP test strip was prepared according to Example 1. The following impregnation formulation for the reagent fleeces was used:

"biotin fleece":	100 mM Hepes pH 7.4, 0.1% Tween ®, 20 µg/ml biotinylated PAB (39-50)
"gold fleece":	100 mM Hepes pH 7.4, OD 4 MAB 18.4.34 (27-31) or MAB 17.3.1 (13-16) gold conjugate

Heparinized blood samples from healthy donors were spiked with sera containing NT-proBNP from heart failure patients and aliquoted. 150 µl of the spiked blood samples was pipetted onto the test strips and measured in a CARDIAC Reader® (Roche Diagnostics). The reaction time after sample detection was 12 minutes. In order to determine the NT-proBNP concentration of the samples, plasma was centrifuged from one aliquot and measured with an Elecsys® NT-proBNP kit (Roche Diagnostics). Function curves obtained in this manner of the two test strip variants MAB 17.3.1 (13-16)/PAB (39-50) and MAB 18.4.34 (27-31)/PAB (39-50) are shown in FIG. 4. The variant MAB 18.4.34 (27-31)/PAB (39-50) has a considerably steeper standard curve and is thus a more sensitive test.

Example 4

Correlation of an NT-proBNP Test Strip with the AB Combination: Au-MAB 18.4.34 (27-31)/Bi-PAB (39-50) to the Elecsys® NT-proBNP Test Kit

Sera containing NT-proBNP from patients with cardiac failure were added to heparinized blood samples from healthy donors and aliquoted. 150 µl of these "spiked" blood samples was pipetted onto the test strips and measured in a CARDIAC Reader® (Roche Diagnostics) according to the standard method. Plasma was centrifuged from the same sample and measured with the Elecsys® NT-proBNP kit on an Elecsys® 1010 analytical system (Roche Diagnostics). 60 samples were prepared in this manner and measured with both systems. FIG. 5 shows the measured values for both systems. The correlation is very good at $r=0.95$.

It is noted that terms like “preferably”, “commonly”, and “typically” are not utilized herein to limit the scope of the claimed invention or to imply that certain features are critical, essential, or even important to the structure or function of the claimed invention. Rather, these terms are merely intended to highlight alternative or additional features that may or may not be utilized in a particular embodiment of the present invention.

For the purposes of describing and defining the present invention it is noted that the term “substantially” is utilized herein to represent the inherent degree of uncertainty that may be attributed to any quantitative comparison, value, measurement, or other representation. The term “substantially” is also utilized herein to represent the degree by which a quantitative representation may vary from a stated reference without resulting in a change in the basic function of the subject matter at issue.

Having described the invention in detail and by reference to specific embodiments thereof, it will be apparent that modifications and variations are possible without departing from the scope of the invention defined in the appended claims. More specifically, although some aspects of the present invention are identified herein as preferred or particularly advantageous, it is contemplated that the present invention is not necessarily limited to these preferred aspects of the invention.

What is claimed is:

1. An immunological test strip device for determining human N-terminal pro-brain natriuretic peptide (NT-proBNP) comprising:

(a) a sample application zone for receiving a liquid sample;
(b) a combination of antibodies, wherein the combination is:

i. a monoclonal antibody that specifically binds an epitope of NT-proBNP, wherein the epitope comprises amino acid residues 27-31 of the sequence of human NT-proBNP;

ii. a polyclonal antibody that specifically binds an epitope of NT-proBNP, wherein the epitope is amino acid residues 38-42 of the sequence of human NT-proBNP;

wherein at least one antibody in the combination of antibodies is attached to a particulate label selected from the group consisting of a gold label, a colored lattice, a metal sol label, a polymer label, a semiconductor nanocrystal and biotin; and

(c) a detection zone in fluid communication with the sample application zone for binding a complex comprising the NT-proBNP and the antibodies of the combination.

2. The device of claim 1, wherein the sample application zone comprises a matrix material.

3. The device of claim 2, wherein the matrix material is impregnated with at least one of the monoclonal antibody and the polyclonal antibody.

4. The device of claim 2, wherein the matrix comprises at least two fleece structures.

5. The device of claim 1, wherein the detection zone comprises at least one immobilized immunochemical component.

6. The device of claim 1, further comprising an erythrocyte separation zone in fluid communication with the sample application zone.

7. The device of claim 6, wherein the erythrocyte separation zone is in fluid communication with the detection zone.

8. The device of claim 1 further comprising a suction zone in fluid communication with the detection zone.

9. The device of claim 1 wherein the test strip device is an immunochromatographic test device.

10. The device of claim 1 wherein the particulate label is a gold label.

11. The device of claim 1 wherein the particulate label is biotin.

12. A method for detecting human N-terminal pro-brain natriuretic peptide (NT-proBNP) comprising:

(a) providing the immunological test strip device of claim 1;

(b) adding a biological sample suspected of containing NT-proBNP to the test strip device; and

(c) determining presence or amount of NT-proBNP in the sample that binds to both the antibodies in the combination of antibodies.

13. A method for determining N-terminal pro-brain natriuretic peptide (NT-proBNP) in a human patient sample, the method comprising:

(a) contacting a patient sample with an immunological test strip device comprising a combination of antibodies, wherein the combination is:

i. a monoclonal antibody that specifically binds an epitope of NT-proBNP, wherein the epitope comprises amino residues 27-31 of the sequence of human NT-proBNP;

ii. a polyclonal antibody that specifically binds an epitope of NT-proBNP, wherein the epitope is amino residues 38-42 of the sequence of human NT-proBNP;

wherein at least one antibody in the combination of antibodies is attached to a particulate label selected from the group consisting of a gold label, a colored lattice, a metal sol label, a polymer label, a semiconductor nanocrystal and biotin;

(b) forming a complex comprising the NT-proBNP from the sample, and the antibodies of the combination, wherein one of the antibodies of the combination is bound to or becomes bound to a detection zone of the test device; and

(c) detecting the complex, thereby determining the NT-proBNP in the sample.

14. The method of claim 13 wherein the sample is whole blood, plasma or serum.

15. The method of claim 13 wherein the particulate label is a gold label.

16. The method of claim 13 wherein the particulate label is a biotin label.

17. An immunological test strip device for determining human N-terminal pro-brain natriuretic peptide (NT-proBNP) comprising a test strip comprising:

(a) a combination of antibodies, wherein the combination is:

i. a monoclonal antibody that specifically binds an epitope of NT-proBNP, wherein the epitope comprises amino acid residues 27-31 of the sequence of human NT-proBNP;

ii. a polyclonal antibody that specifically binds an epitope of NT-proBNP, wherein the epitope is amino acid residues 38-42 of the sequence of human NT-proBNP;

wherein at least one antibody in the combination of antibodies is attached to a particulate label selected from the group consisting of a gold label, a colored lattice, a metal sol label, a polymer label, a semiconductor nanocrystal and biotin;

(b) a sample application zone for receiving a liquid sample, wherein the sample application zone comprises a matrix

material impregnated with at least one of the mono-
clonal antibody and the polyclonal antibody; and
(c) a detection zone in fluid communication with the
sample application zone for binding a complex compris- 5
ing the NT-proBNP and the antibodies of the combina-
tion.

* * * * *

专利名称(译)	用于测定NT-proBNP的分析夹心试验		
公开(公告)号	US9140709	公开(公告)日	2015-09-22
申请号	US12/354410	申请日	2009-01-15
[标]申请(专利权)人(译)	罗氏诊断运营		
申请(专利权)人(译)	罗氏诊断业务, INC.		
当前申请(专利权)人(译)	罗氏诊断业务, INC.		
[标]发明人	SPINKE JUERGEN NICHTL ALFONS KLEMT VOLKER HALLERMAYER KLAUS GROL MICHAEL BORGIA ANNELIESE GALLUSSER ANDREAS		
发明人	SPINKE, JUERGEN NICHTL, ALFONS KLEMT, VOLKER HALLERMAYER, KLAUS GROL, MICHAEL BORGIA, ANNELIESE GALLUSSER, ANDREAS		
IPC分类号	G01N33/74 G01N33/543 G01N33/558 C07K16/26 G01N33/53 G01N33/577 G01N33/68		
CPC分类号	G01N33/74 C07K16/26 G01N33/5302 G01N33/543 G01N33/558 C07K2317/34 G01N2333/58 Y10S436/811 Y10S530/80		
优先权	10355731 2003-11-28 DE		
其他公开文献	US20090123947A1		
外部链接	Espacenet USPTO		

摘要(译)

本发明涉及用于测定NT-proBNP的免疫学试验, 所述NT-proBNP包含至少两种针对NT-proBNP的抗体, 其中至少一种针对NT-proBNP的抗体是单克隆抗体。抗体识别的表位可略微重叠。

