



(19) **United States**

(12) **Patent Application Publication**
Kreimer et al.

(10) **Pub. No.: US 2004/0023293 A1**

(43) **Pub. Date: Feb. 5, 2004**

(54) **BIOCHIPS FOR CHARACTERIZING BIOLOGICAL PROCESSES**

(76) Inventors: **David I. Kreimer**, Berkeley, CA (US);
Thomas H. Nufert, Walnut Creek, CA (US);
Lev Ginzburg, Fremont, CA (US);
Oleg A. Yevin, Oakland, CA (US)

Correspondence Address:
Sheldon R. Meyer
FLIESLER DUBB MEYER & LOVEJOY LLP
Fourth Floor
Four Embarcadero Center
San Francisco, CA 94111-4156 (US)

(60) Provisional application No. 60/156,195, filed on Sep. 27, 1999. Provisional application No. 60/336,445, filed on Nov. 14, 2001.

Publication Classification

(51) **Int. Cl.⁷** **G01N 33/53**; G01N 33/574;
C12M 1/34

(52) **U.S. Cl.** **435/7.1**; 435/7.23; 435/287.2

(57) **ABSTRACT**

(21) Appl. No.: **10/294,385**

(22) Filed: **Nov. 14, 2002**

Related U.S. Application Data

(63) Continuation-in-part of application No. 09/925,189, filed on Aug. 8, 2001, which is a continuation-in-part of application No. 09/815,909, filed on Mar. 23, 2001, and which is a continuation-in-part of application No. 09/670,453, filed on Sep. 26, 2000.

This invention includes biochips for analysis of a variety of molecules, cell components and cells. Embodiments of this invention include devices and methods for the parallel and/or nearly parallel processing of biological analytes. Biochips can comprise a substrate, Raman signal-enhancing structures, and receptors selective and/or specific for the analyte(s) to be assayed. Biochips can be read using a Raman reader and can provide for rapid, sensitive, direct assays for physiological and/or pathophysiological conditions of interest.

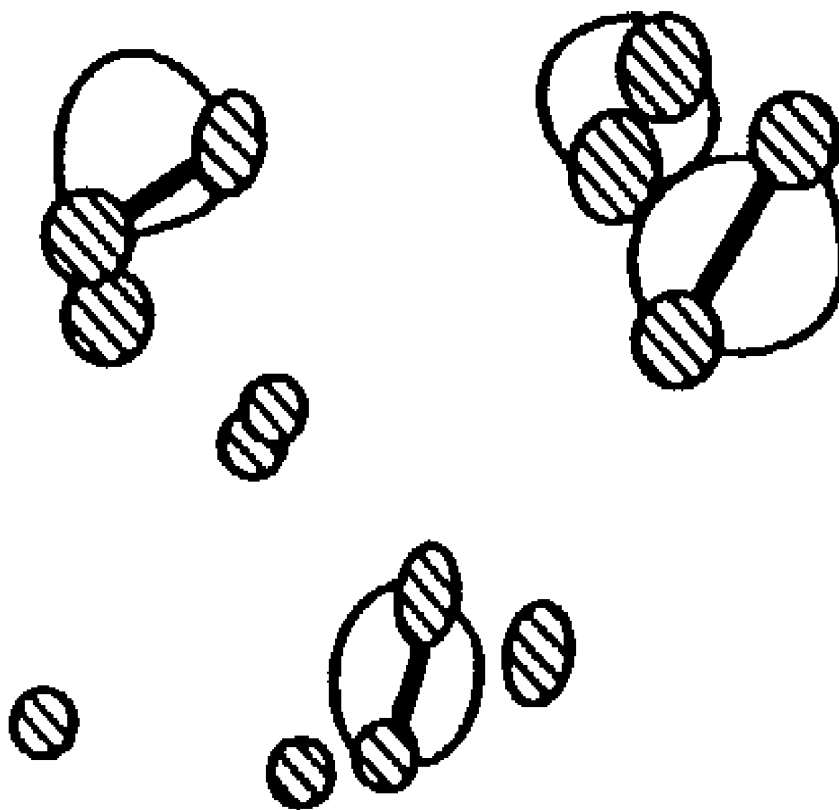

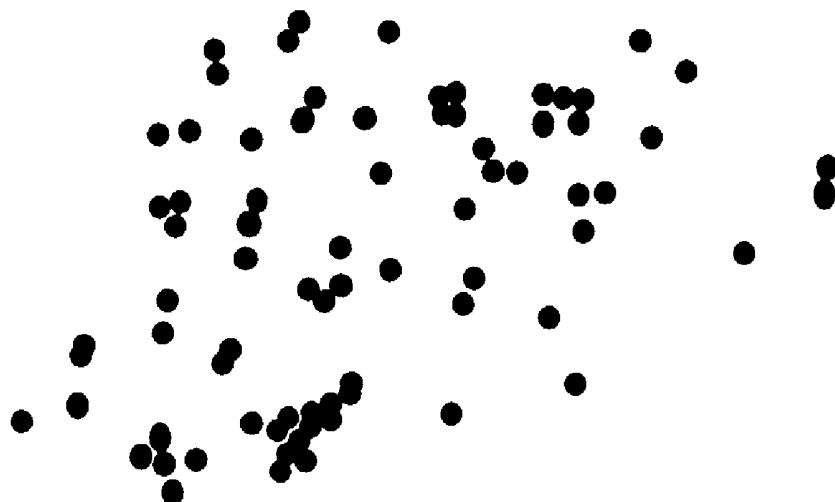

FIG. 1

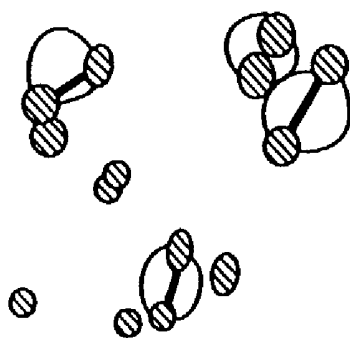

FIG. 2

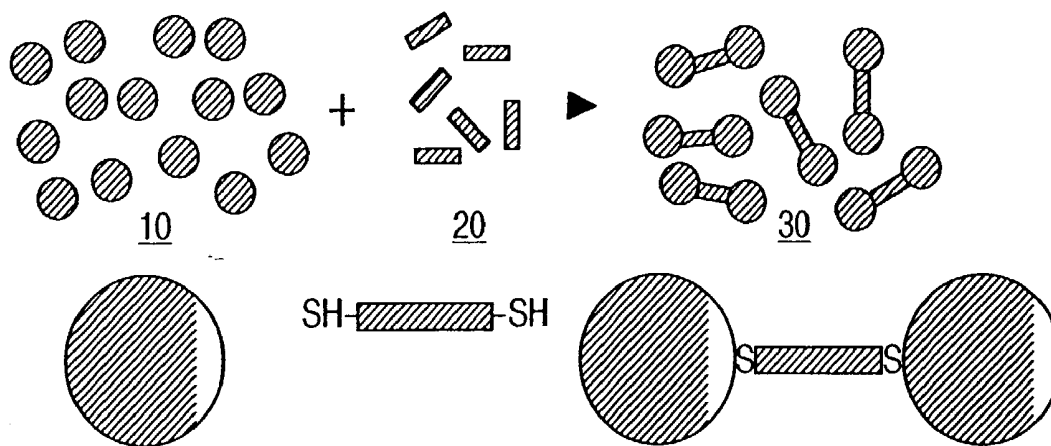

FIG. 3a

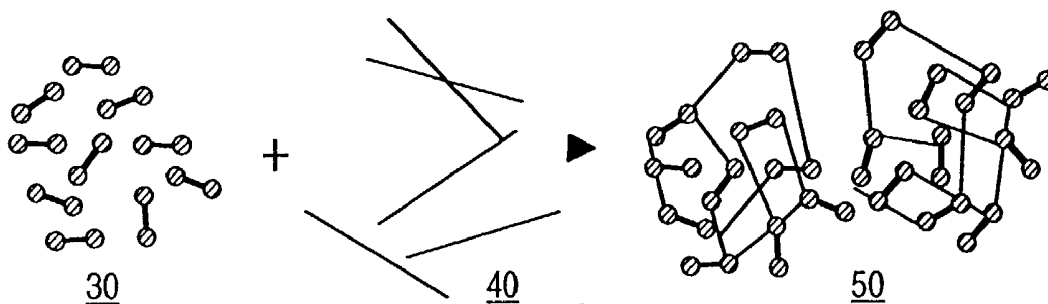

FIG. 3b

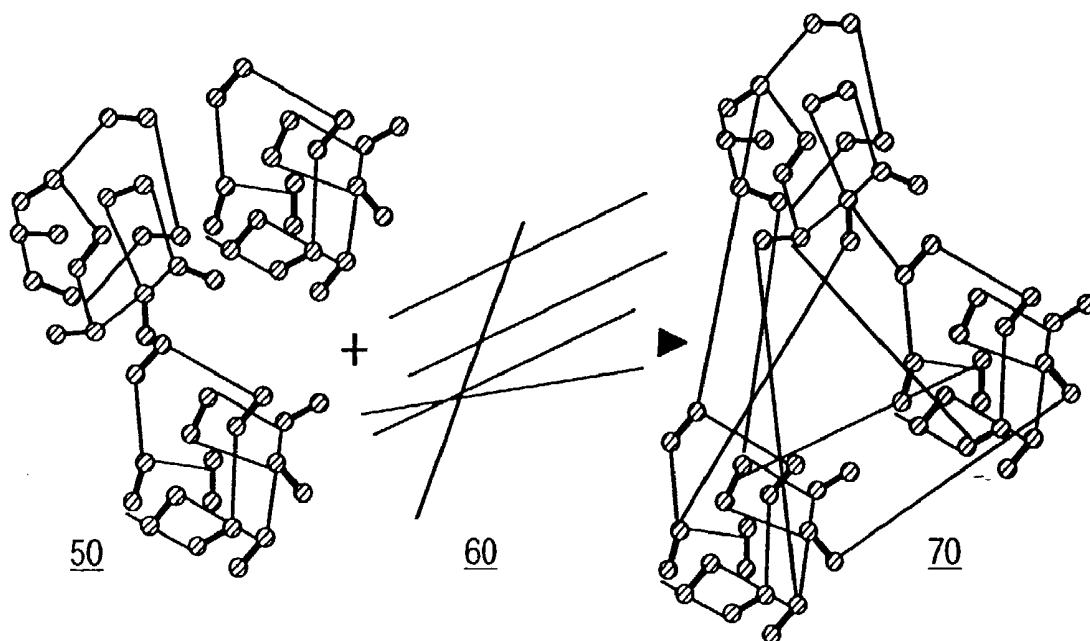

FIG. 3c

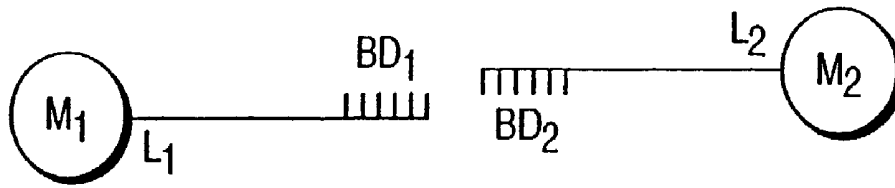

FIG. 4a

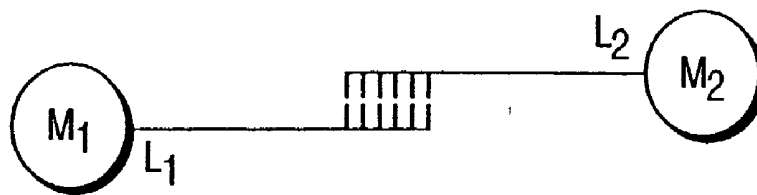

FIG. 4b

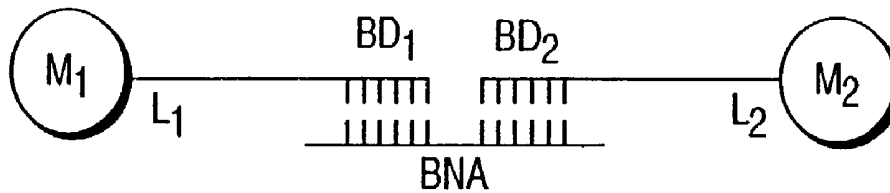

FIG. 4c

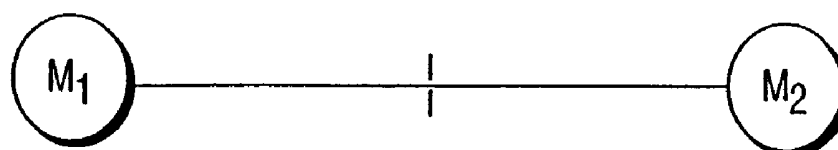

FIG. 4d

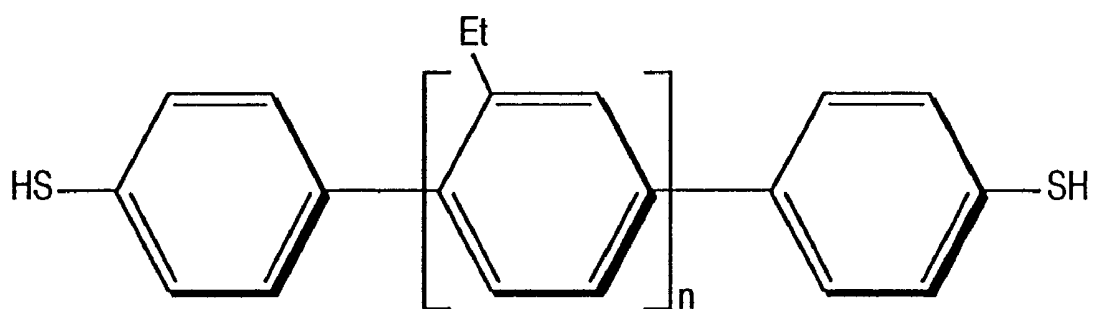

FIG. 5

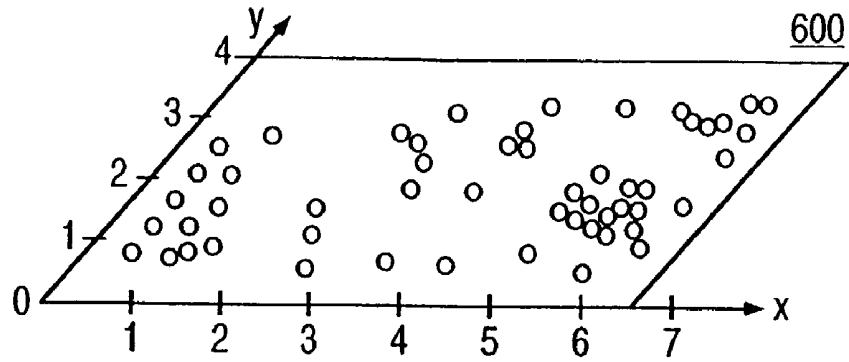

FIG. 6a

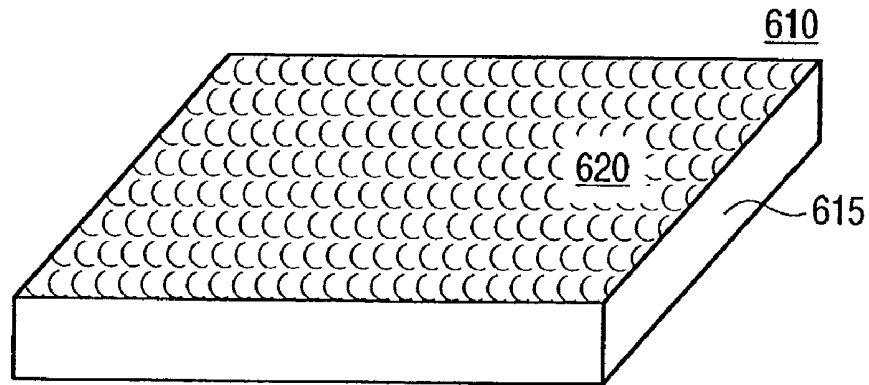

FIG. 6b

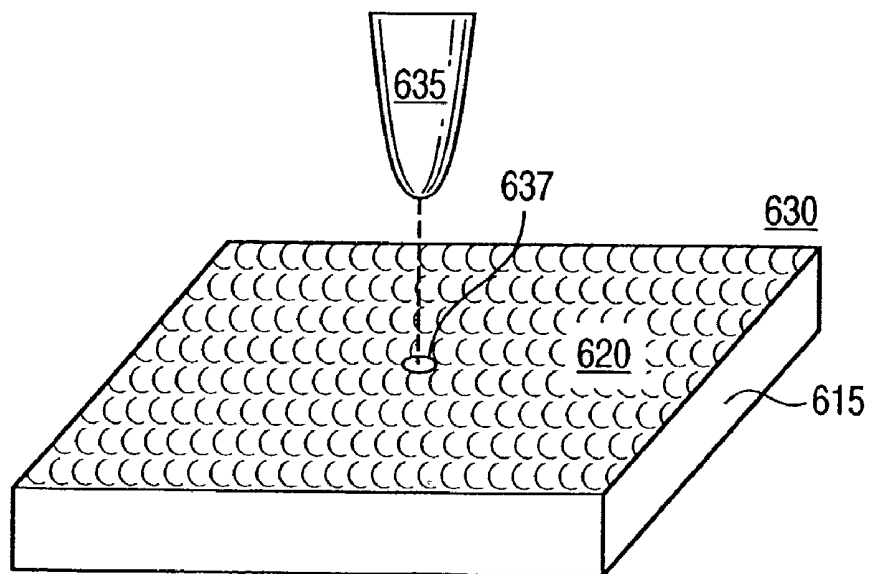

FIG. 6c

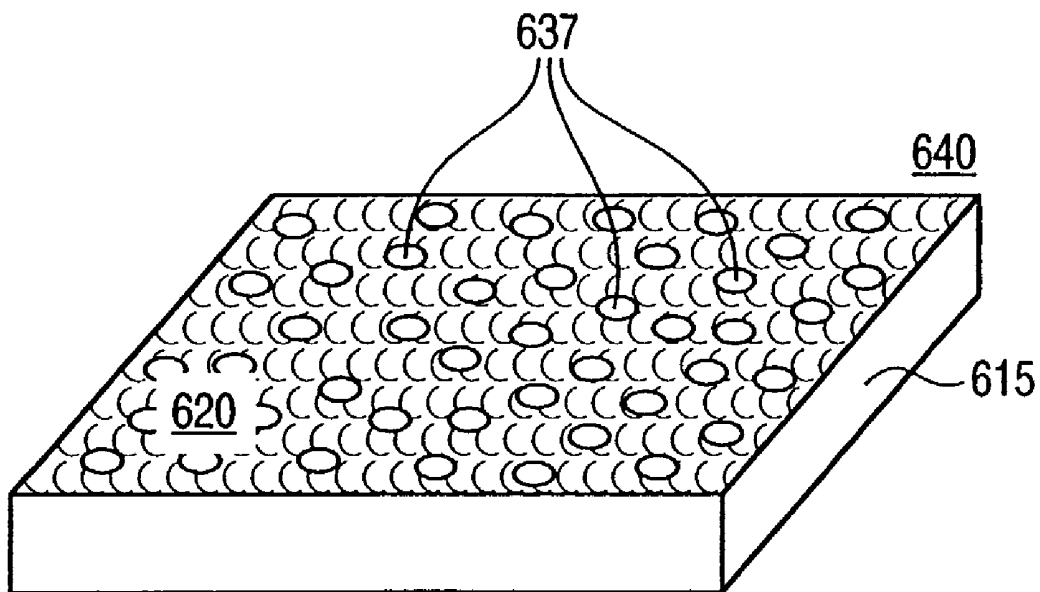

FIG. 6d

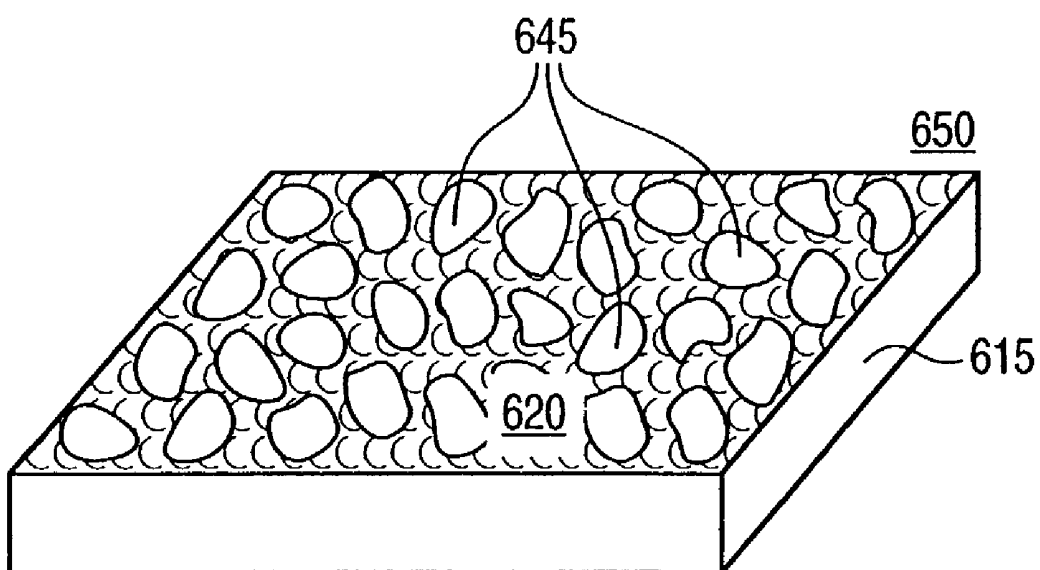

FIG. 6e

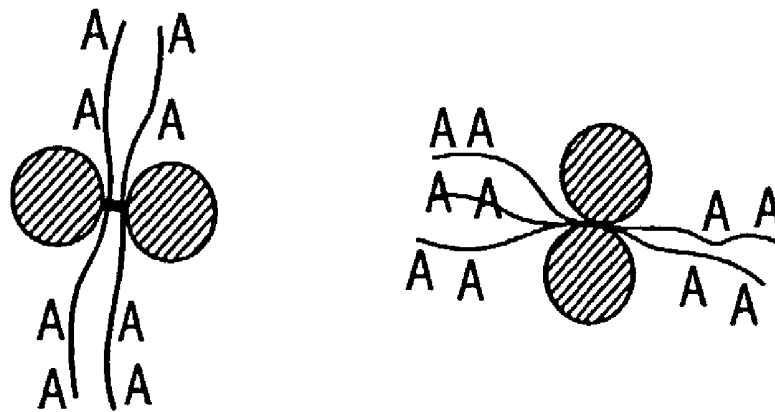

FIG. 7a

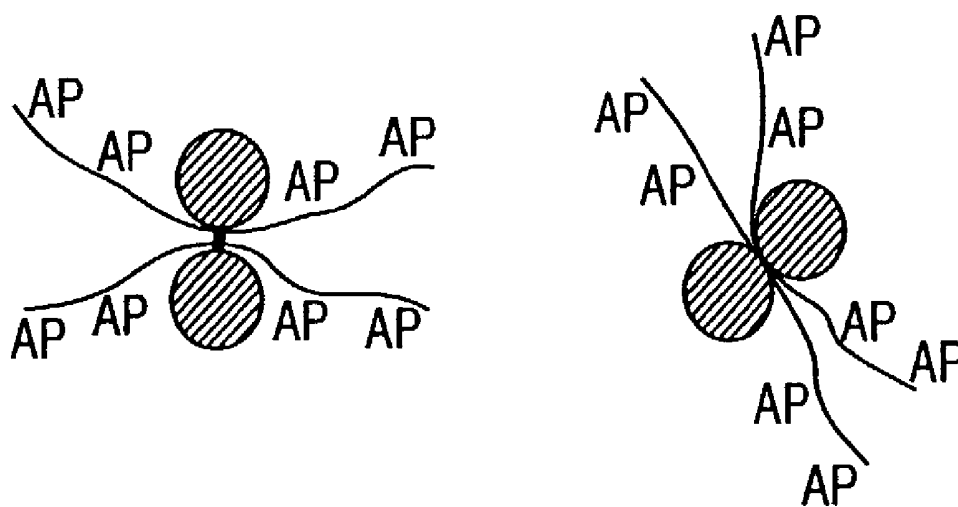

FIG. 7b

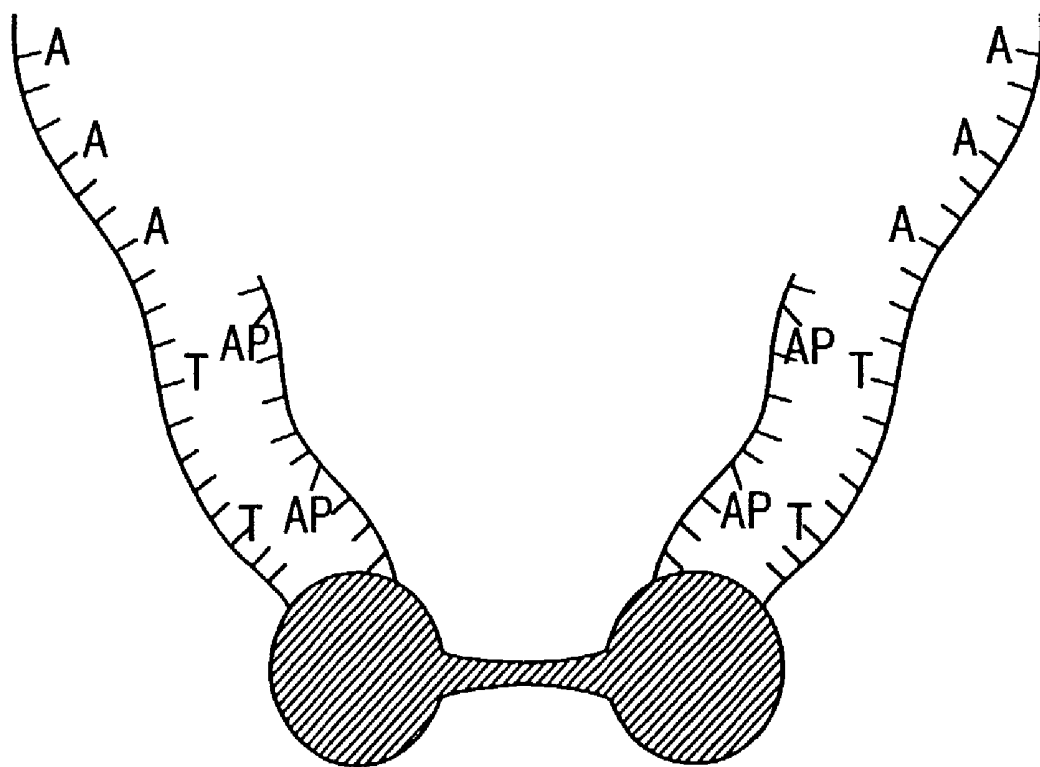

FIG. 8a

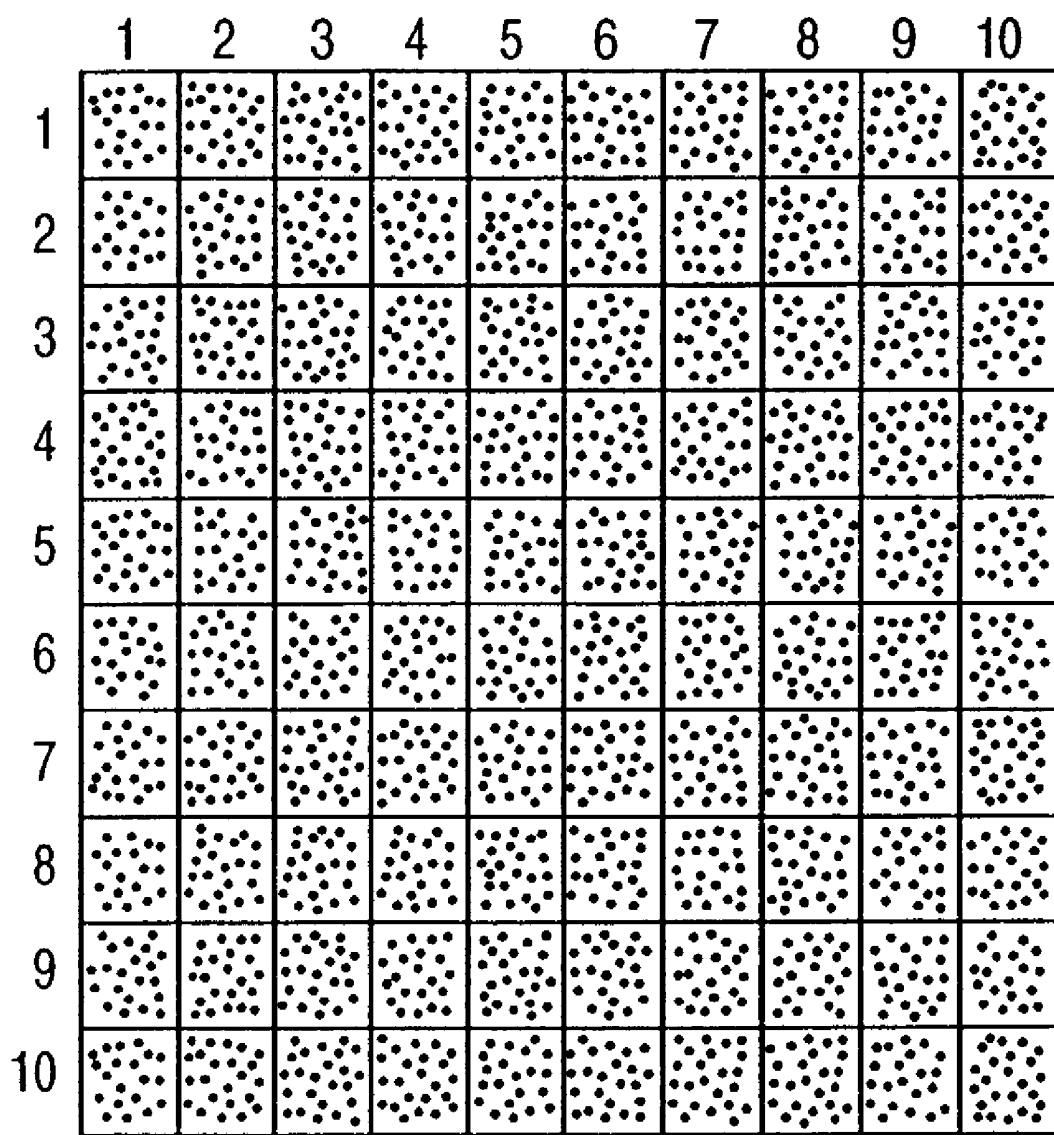

FIG. 8b

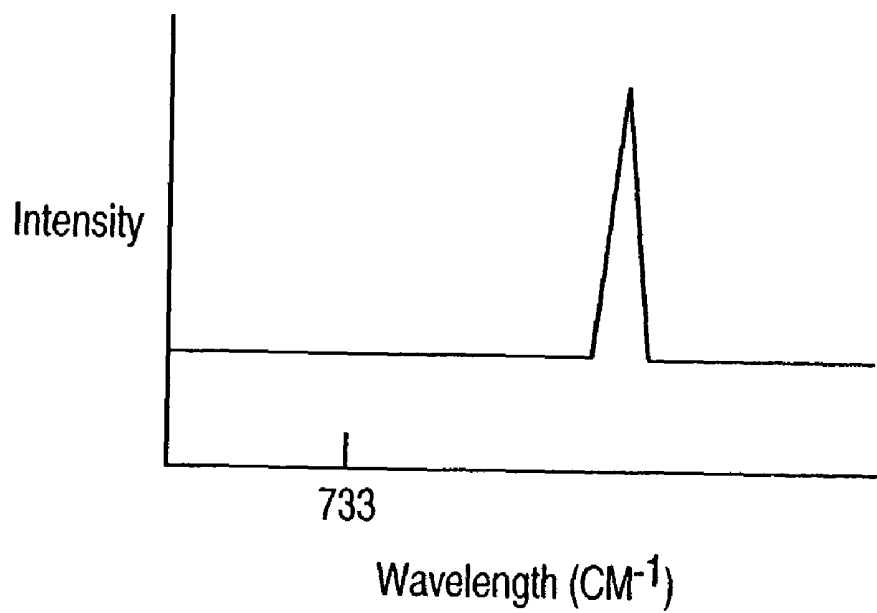

FIG. 9a

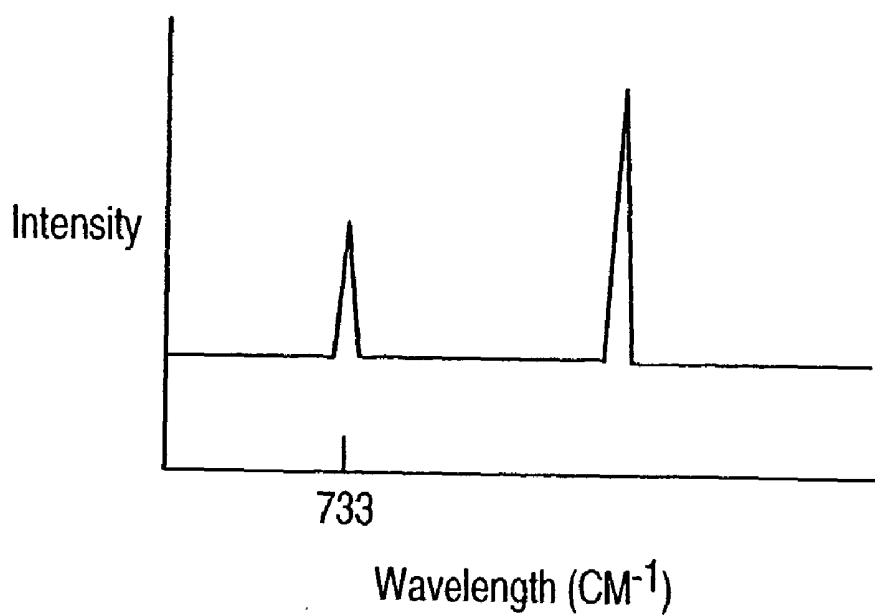

FIG. 9b

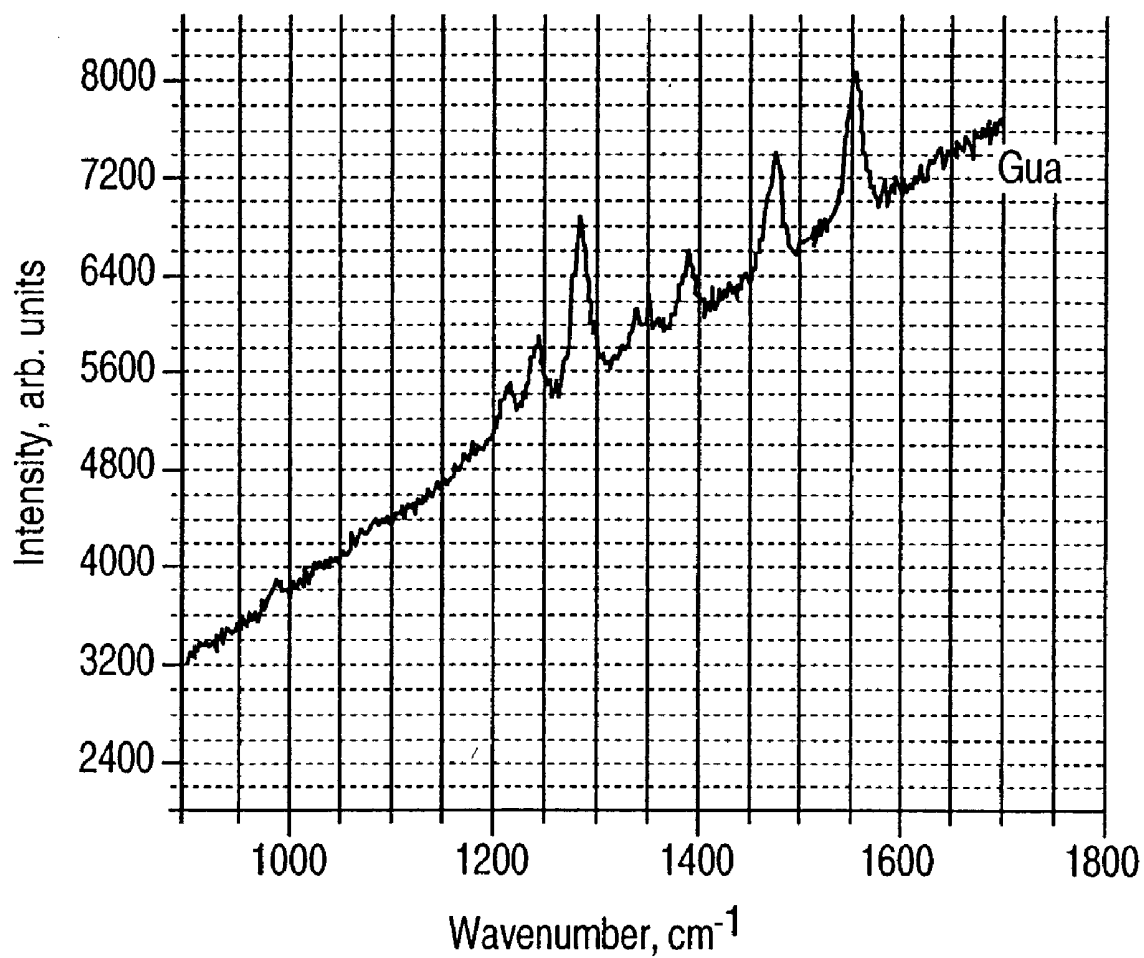

FIG. 9c

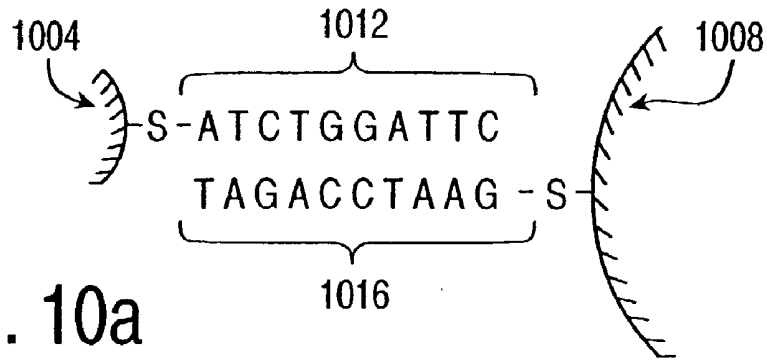

FIG. 10a

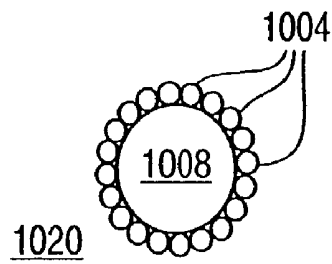

FIG. 10b

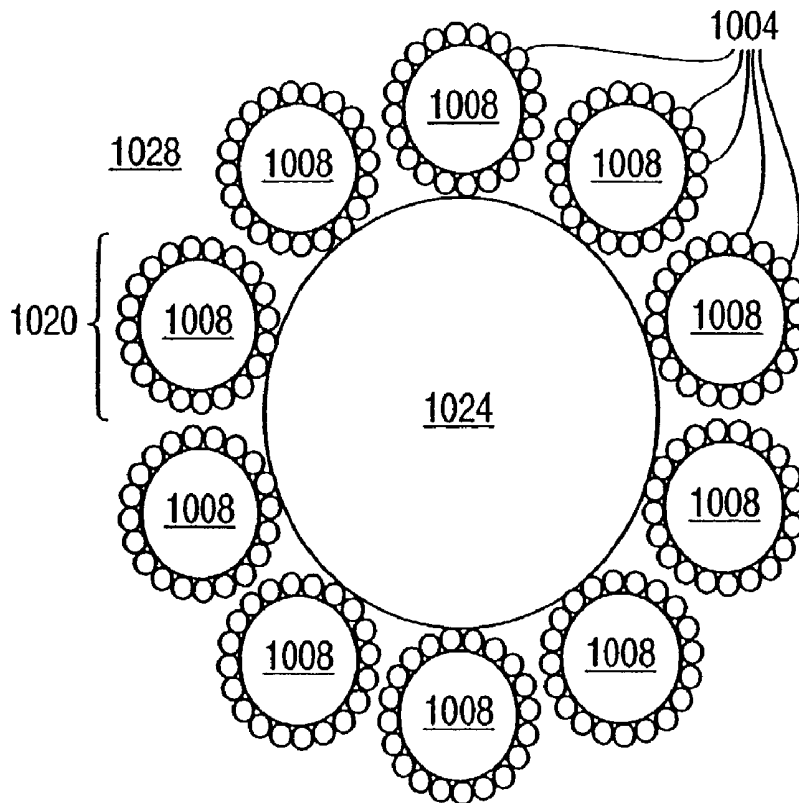

FIG. 10c

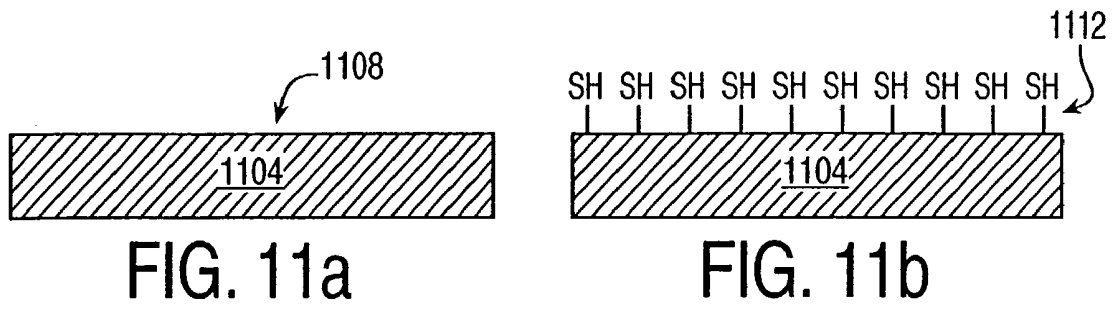
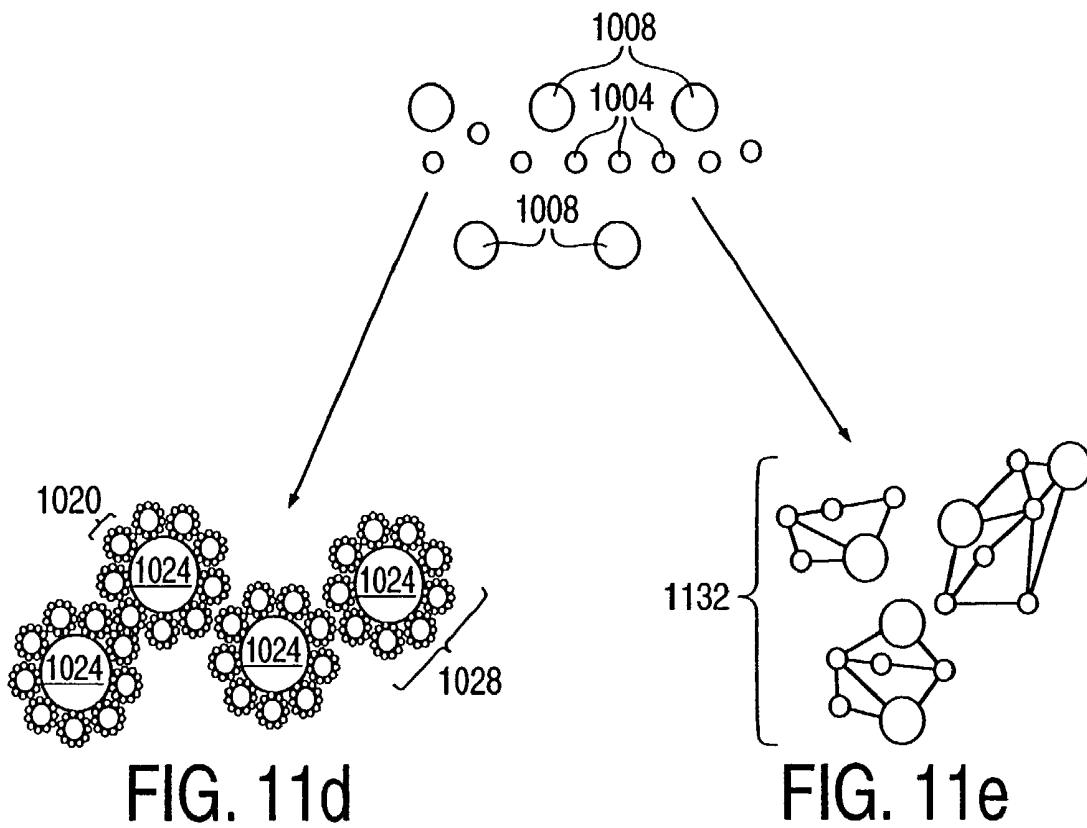

FIG. 11c



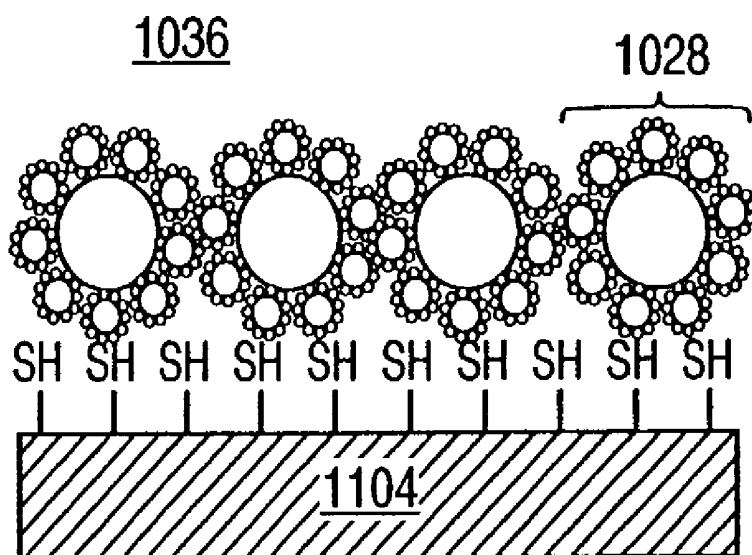

FIG. 11f

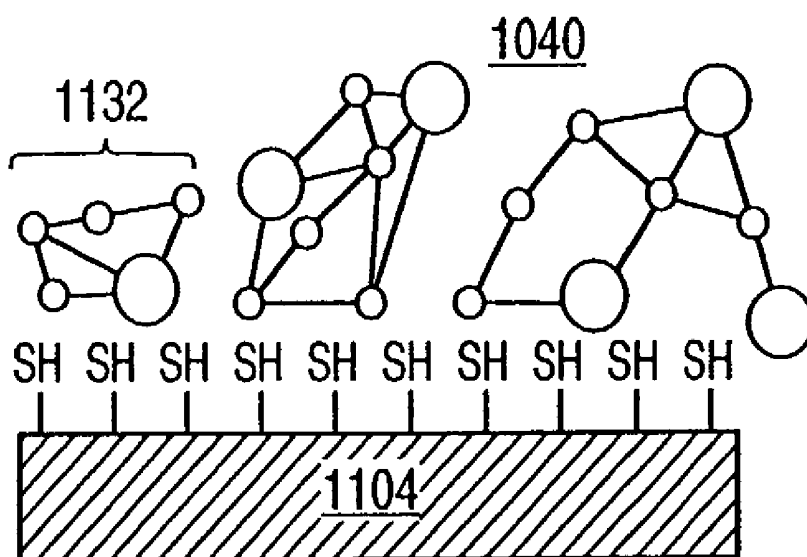

FIG. 11g

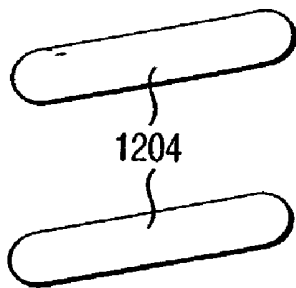

FIG. 12a

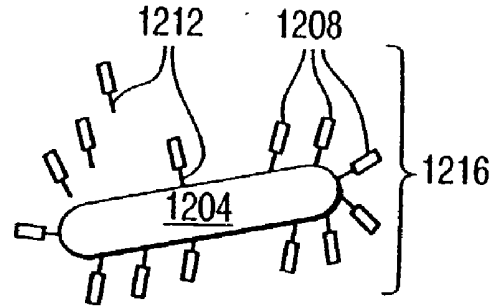

FIG. 12b

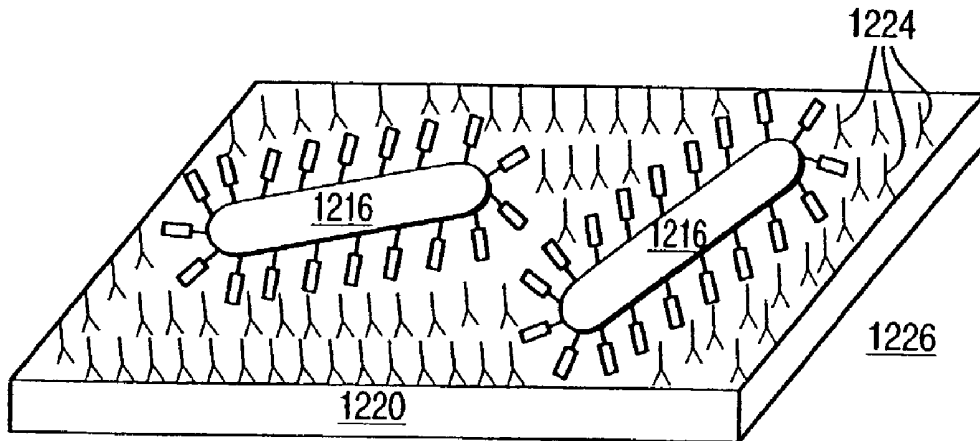

FIG. 12c

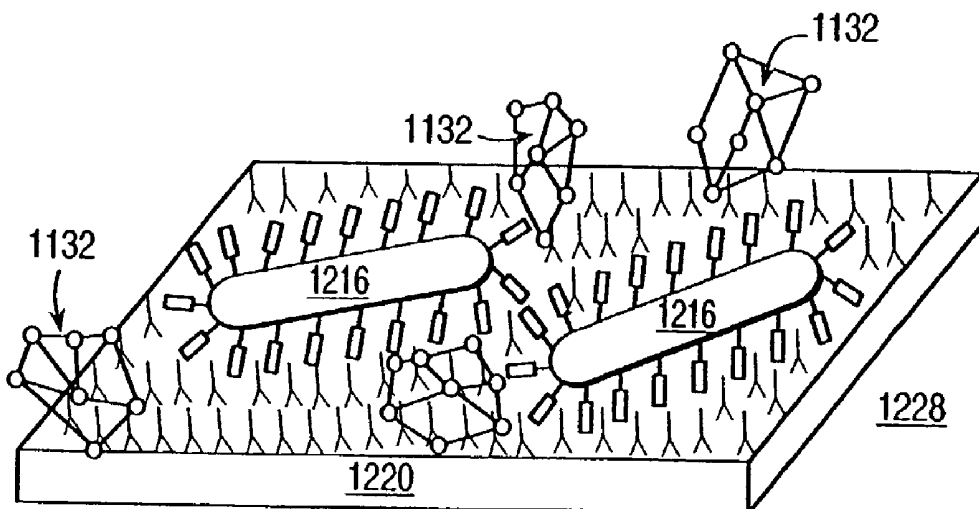

FIG. 12d

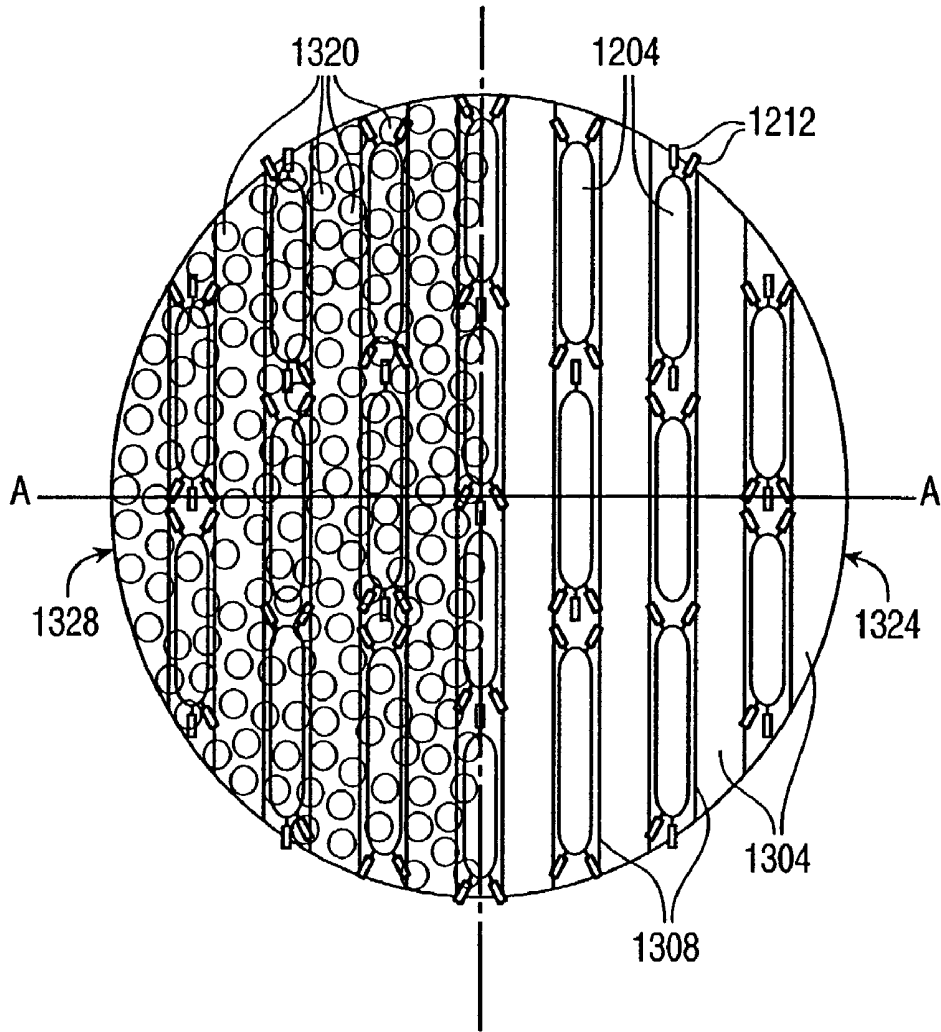

FIG. 13a

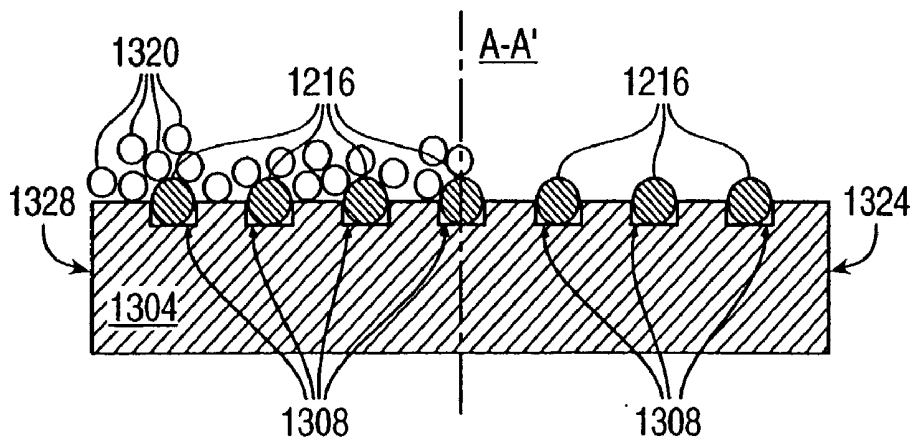

FIG. 13b

FIG. 14a
(Prior Art)

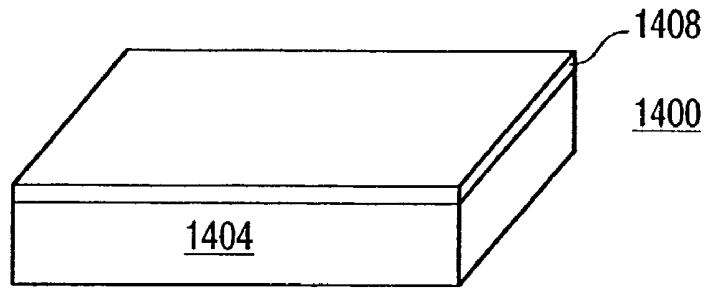

FIG. 14b

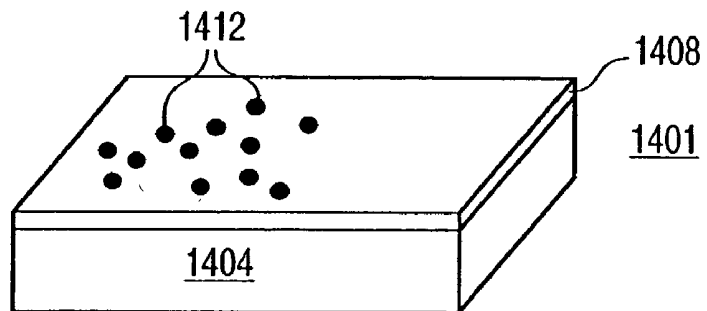

FIG. 14c

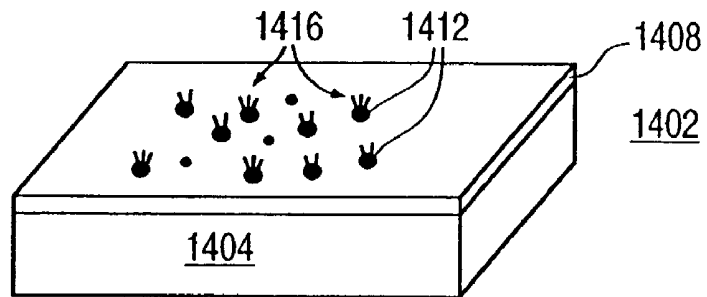
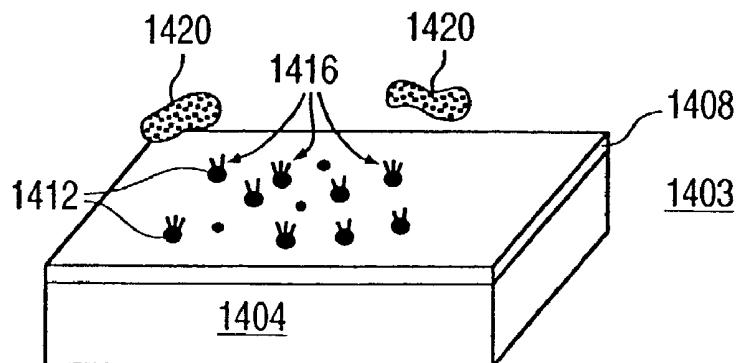

FIG. 14d



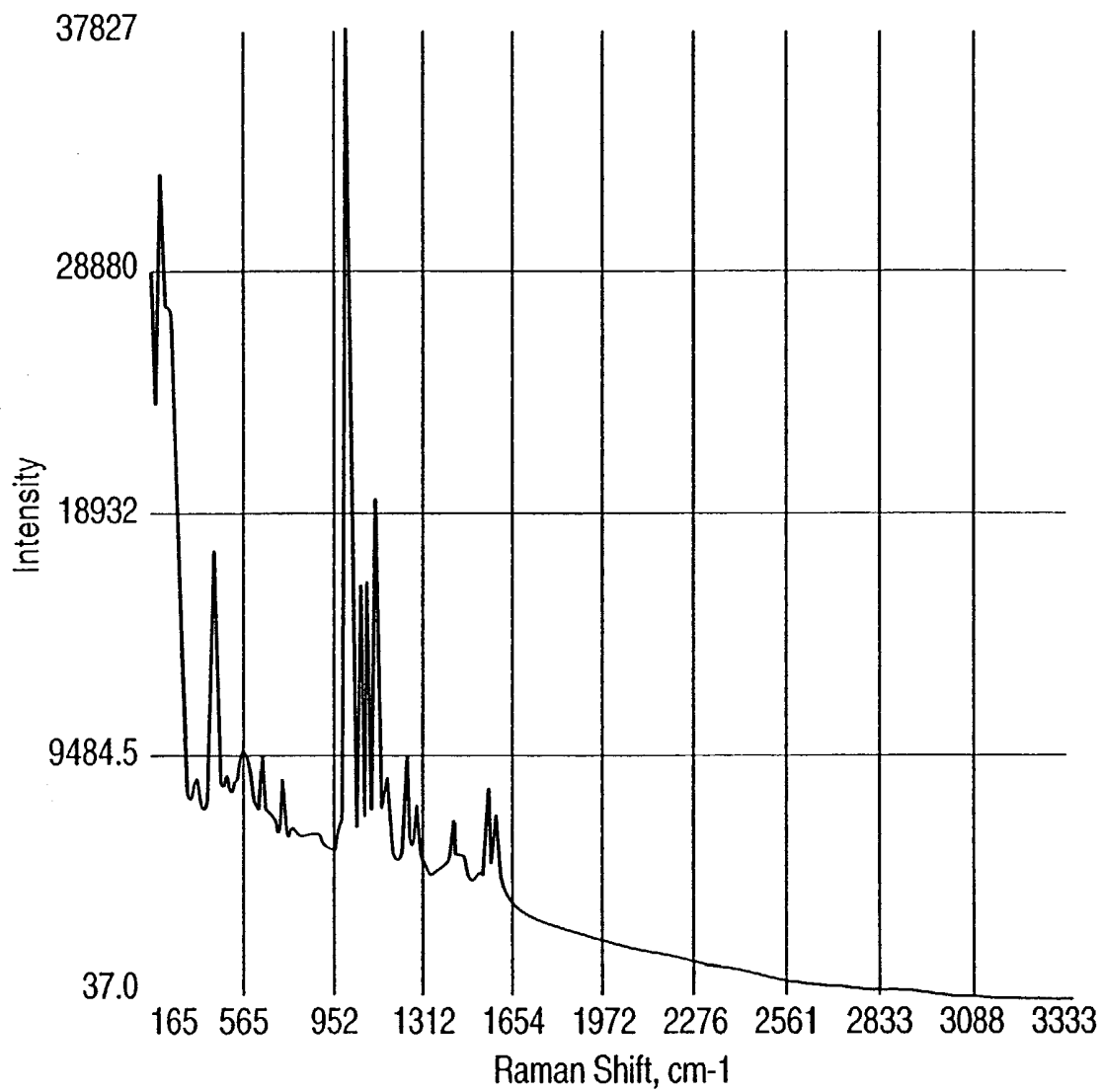

FIG. 15a

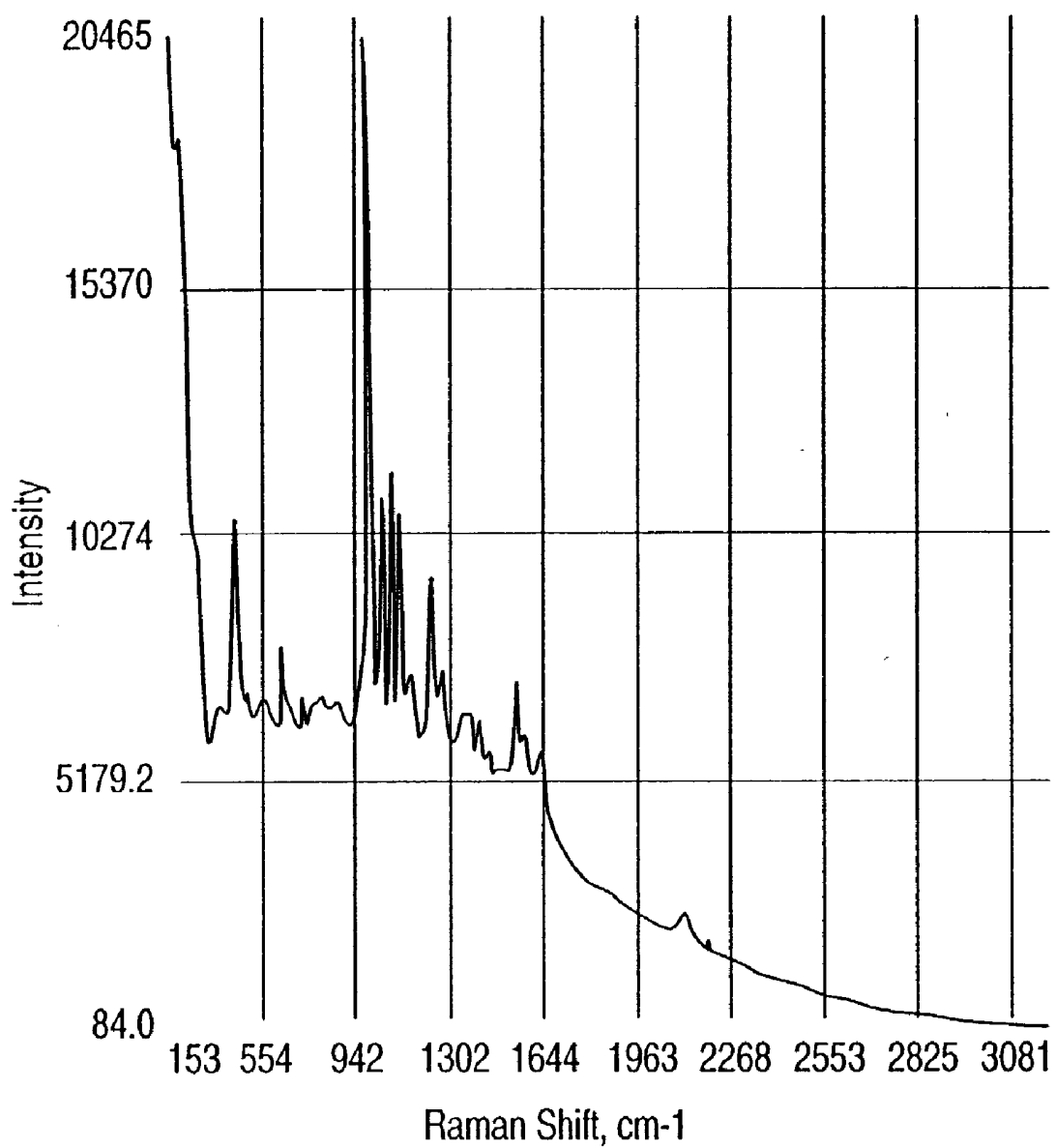

FIG. 15b

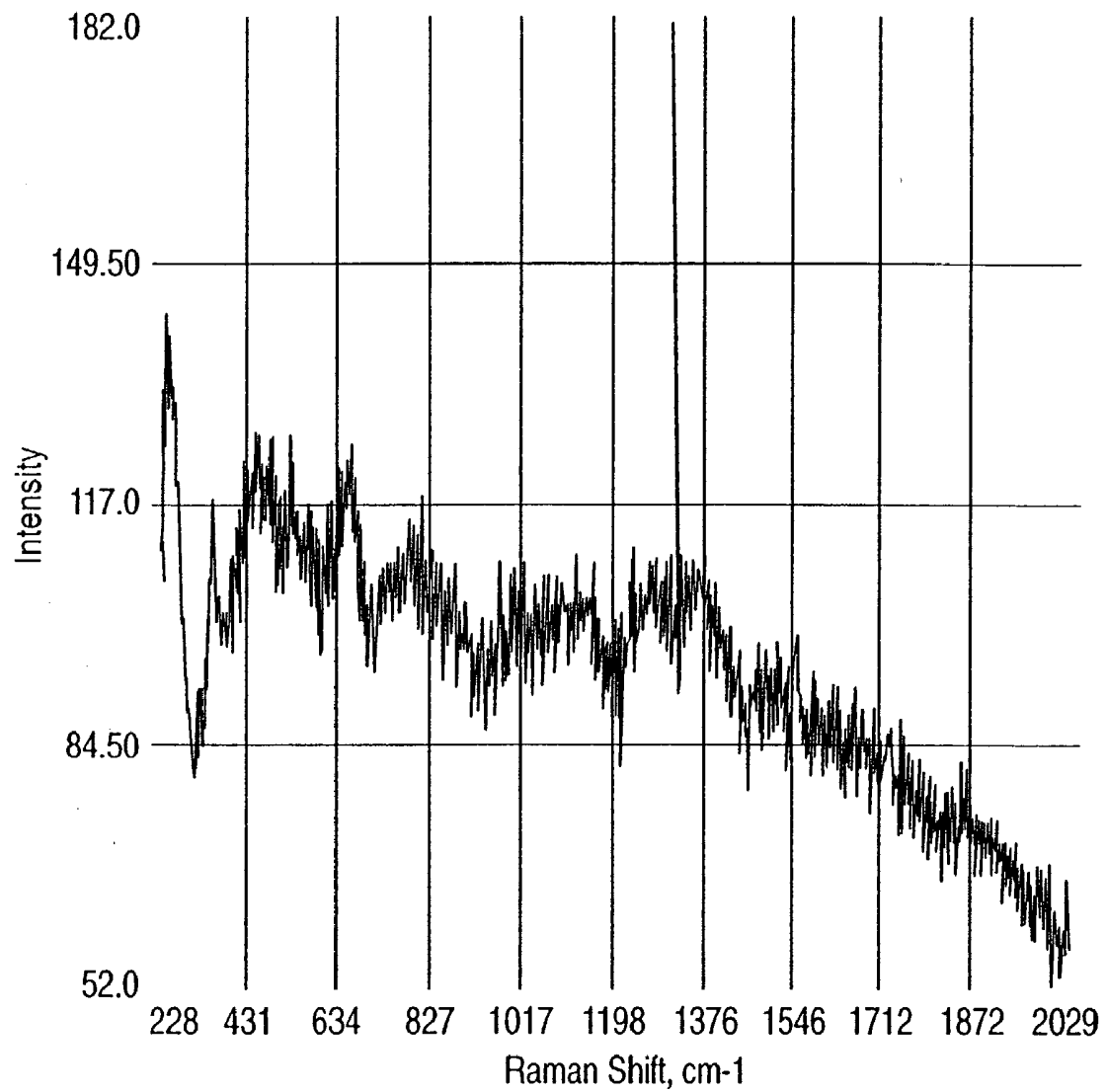

FIG. 16a

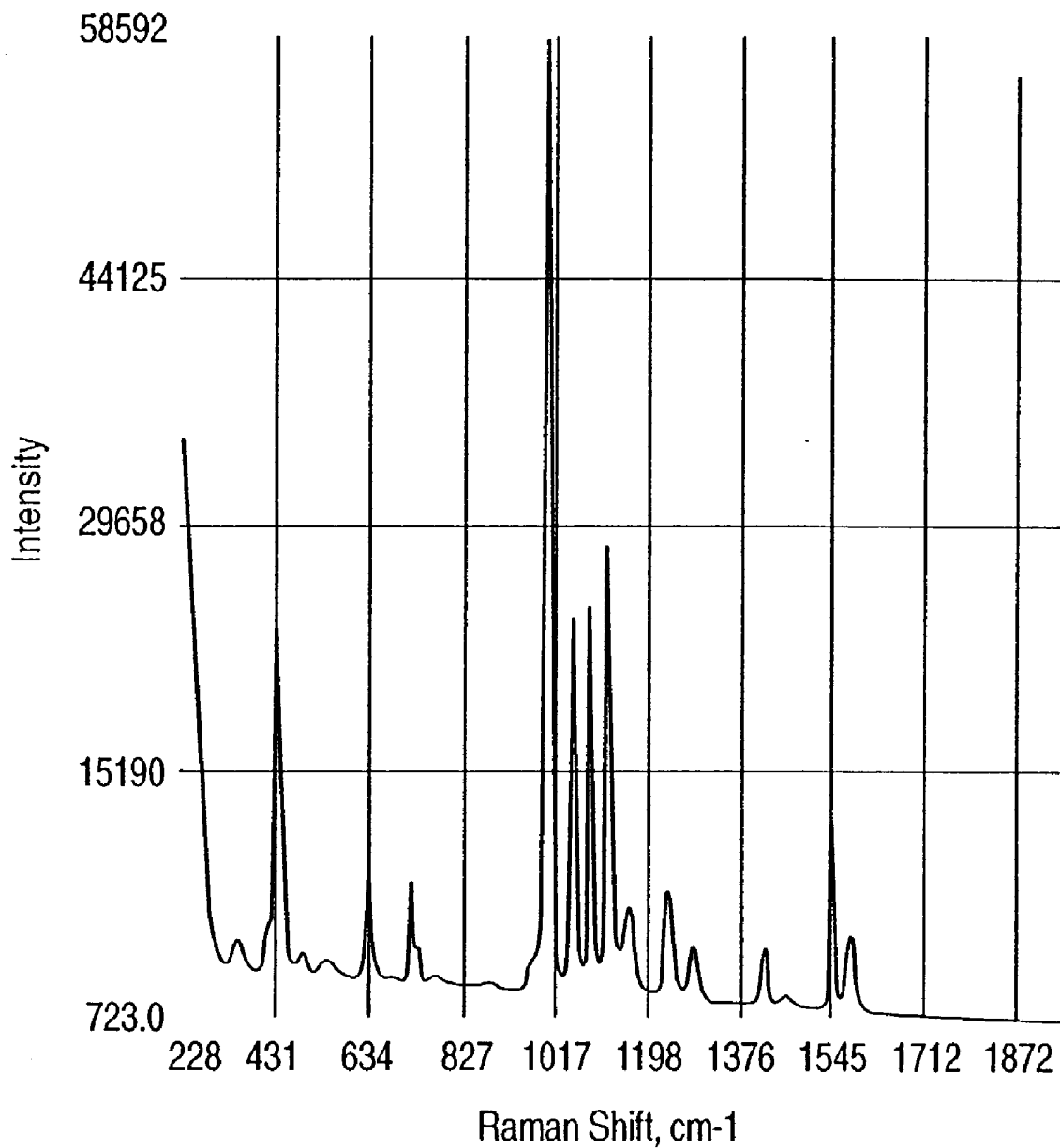

FIG. 16b

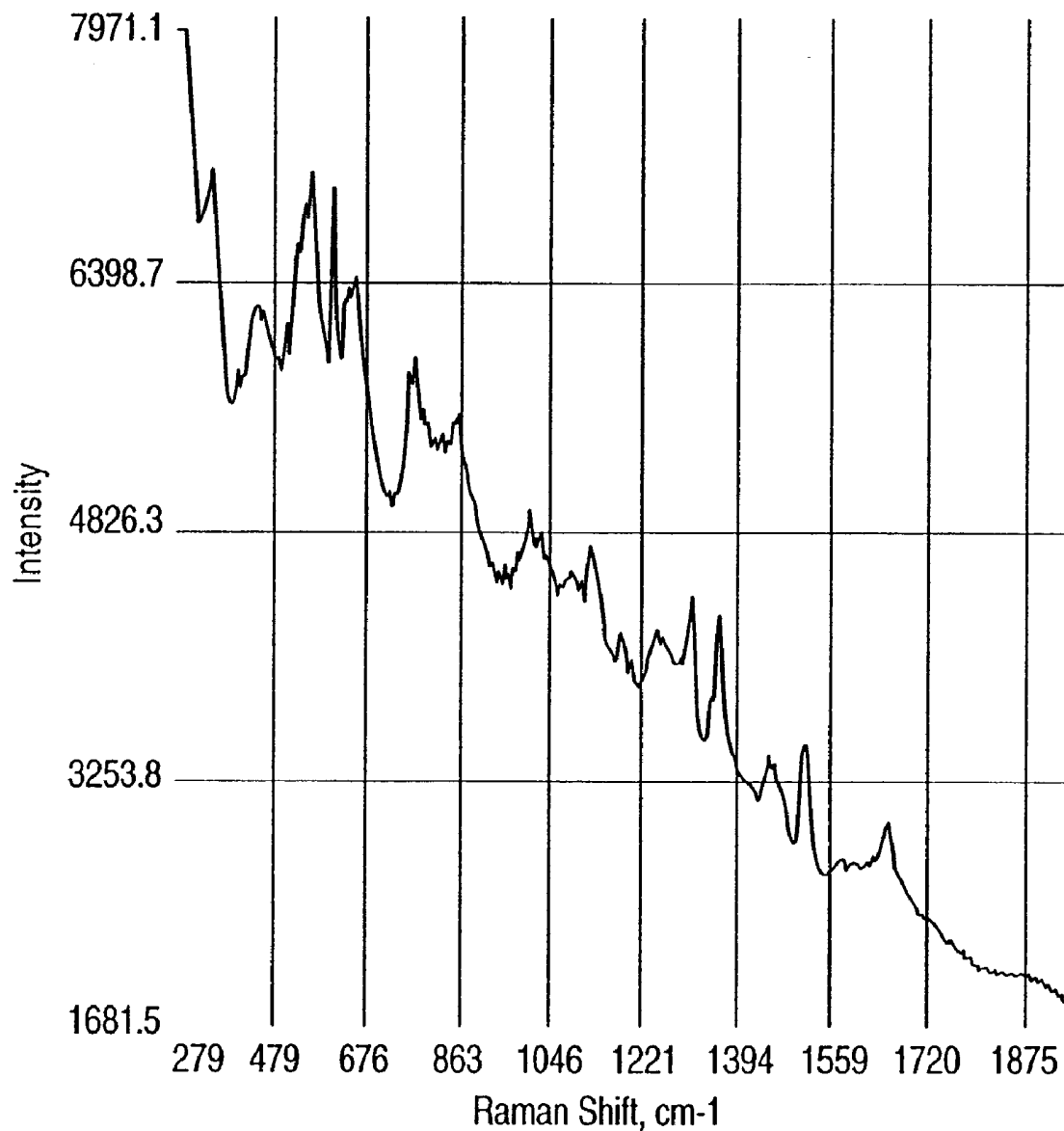

FIG. 16c

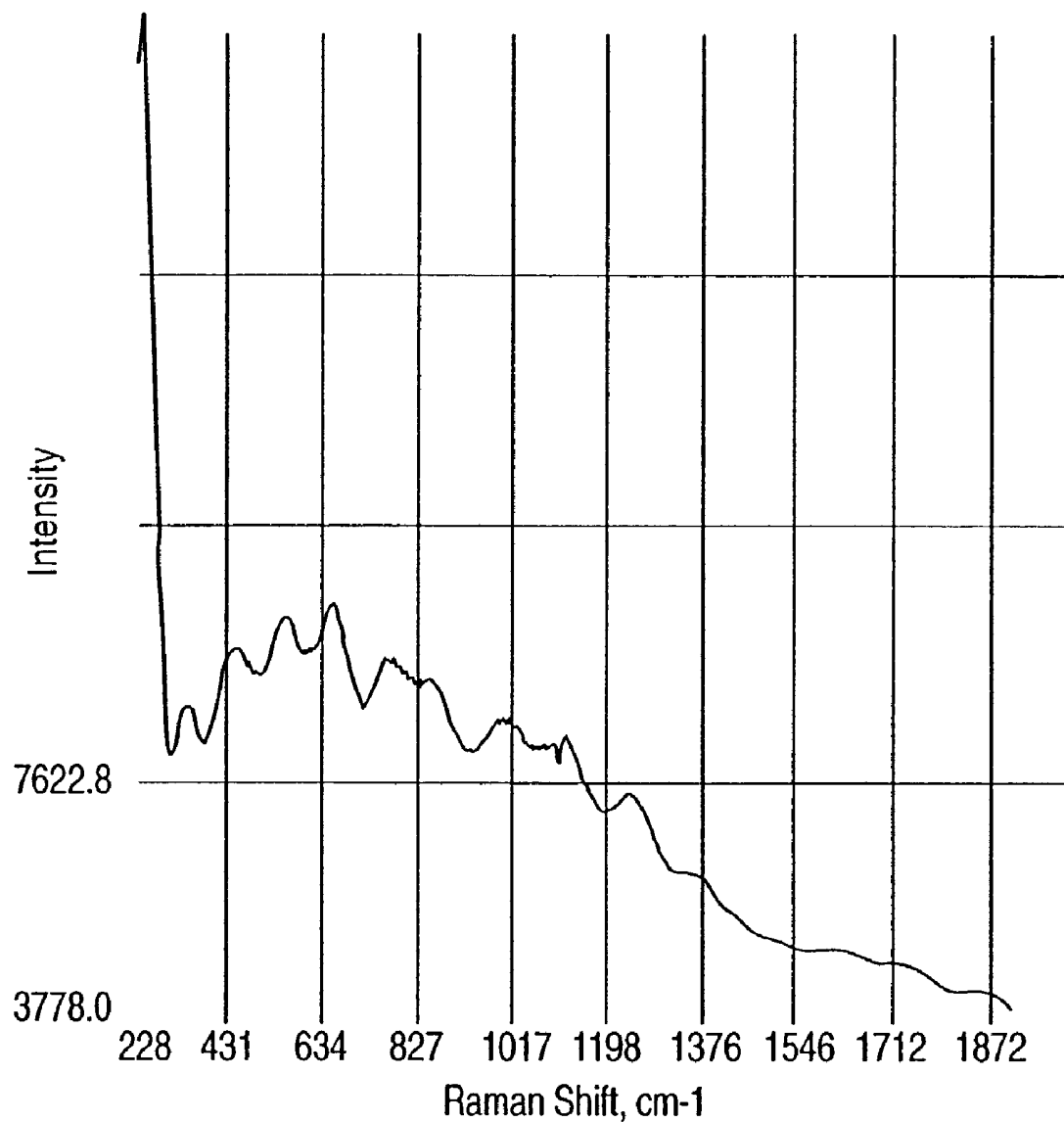

FIG. 16d

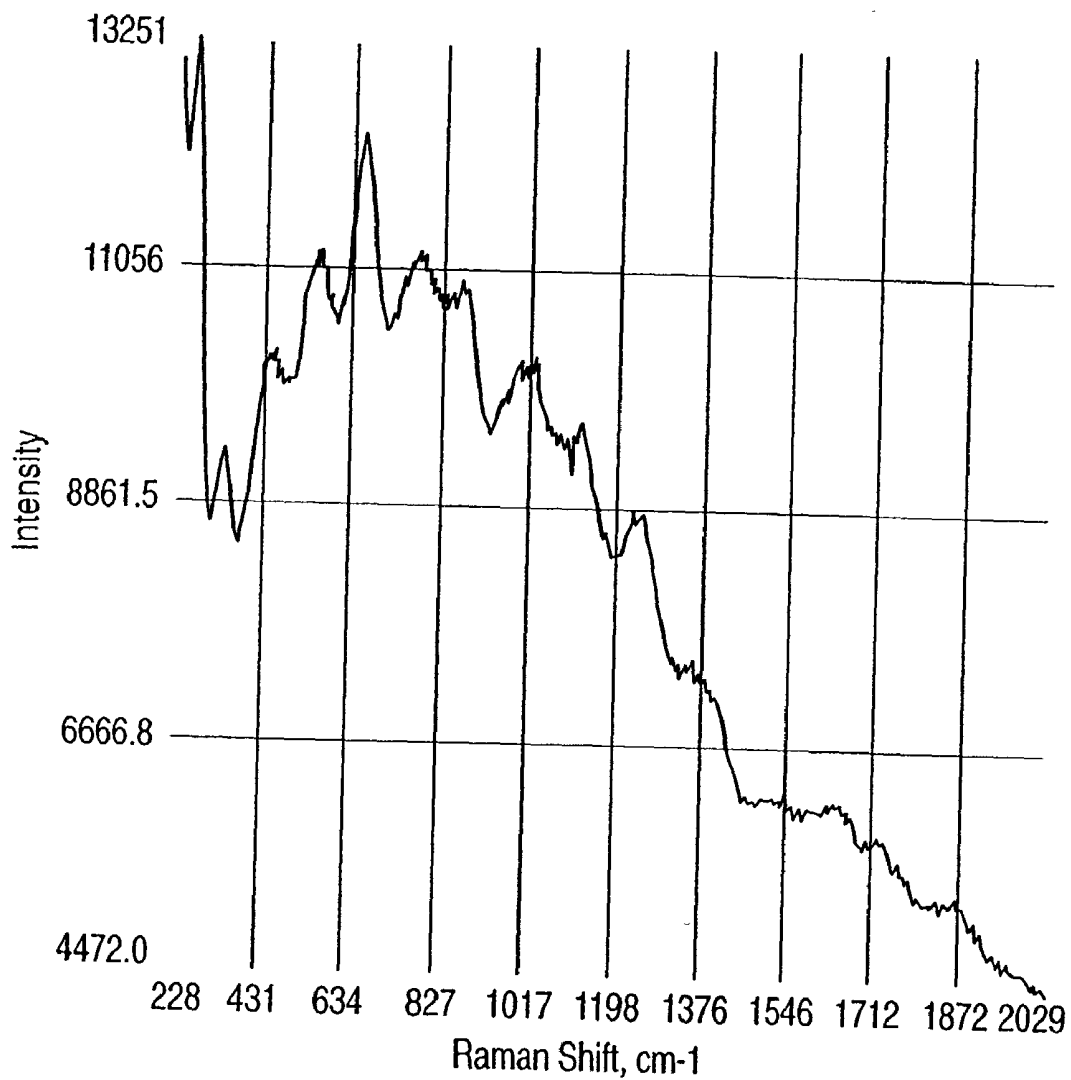

FIG. 16e

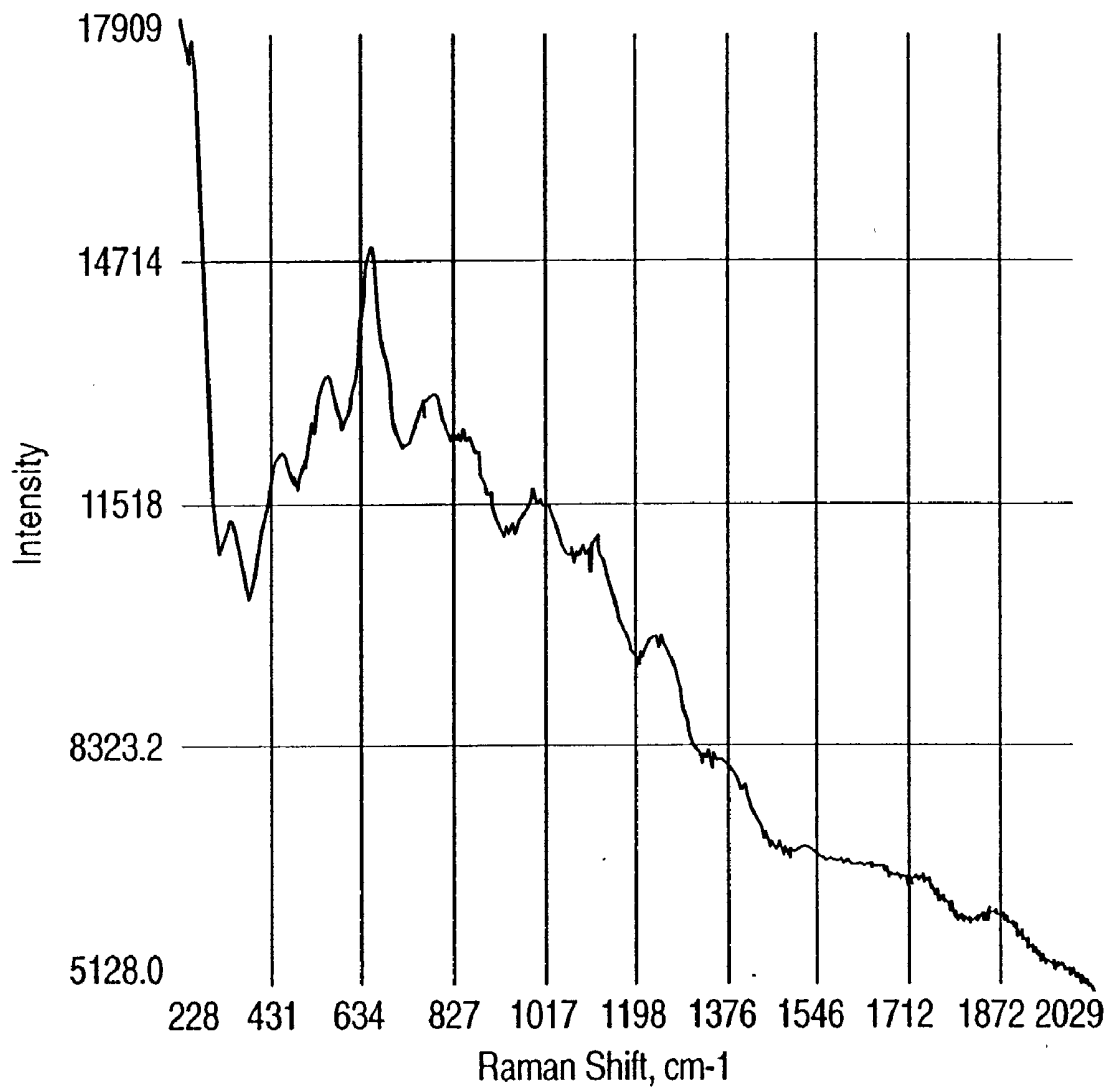

FIG. 16f

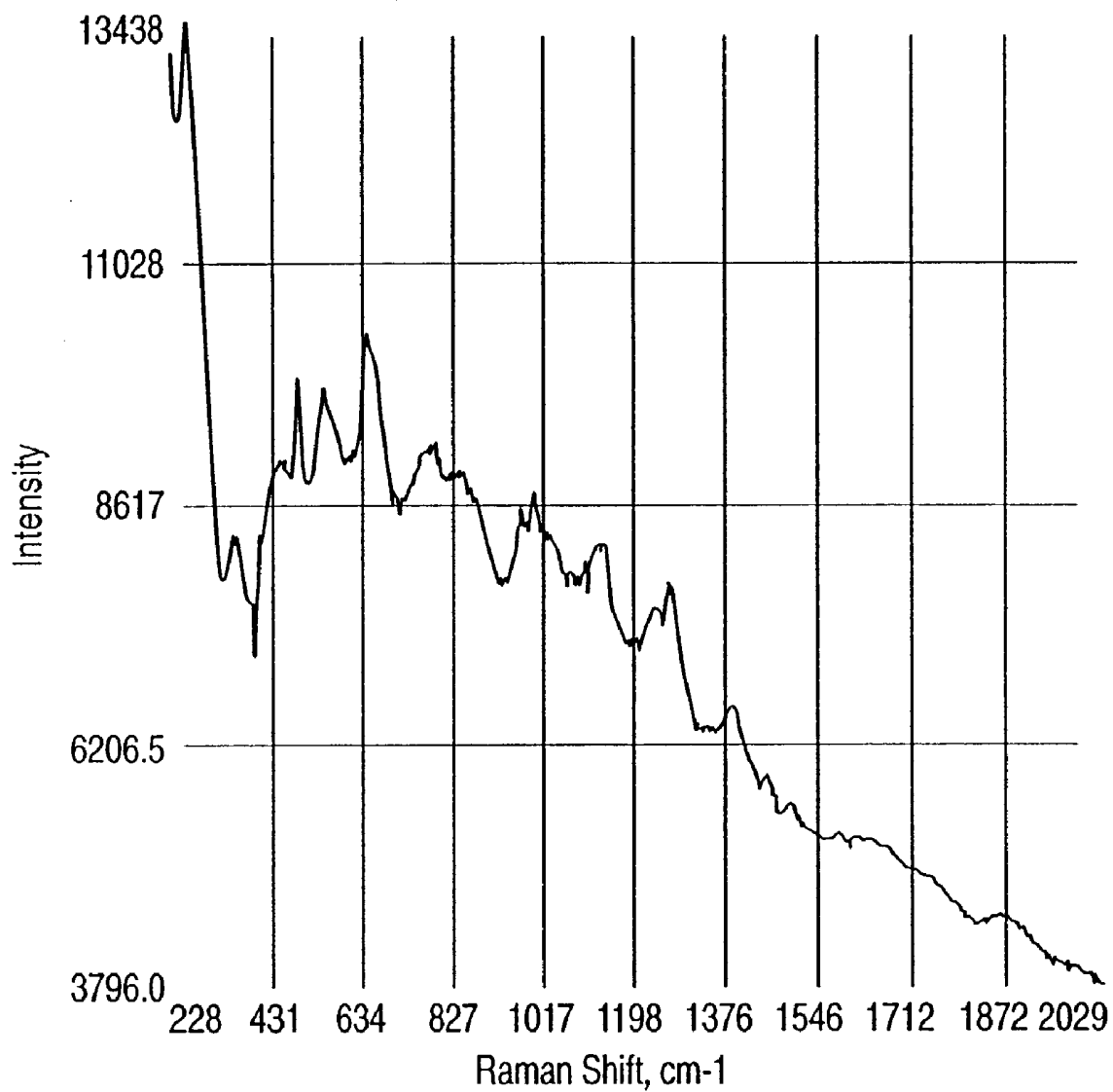

FIG. 16g

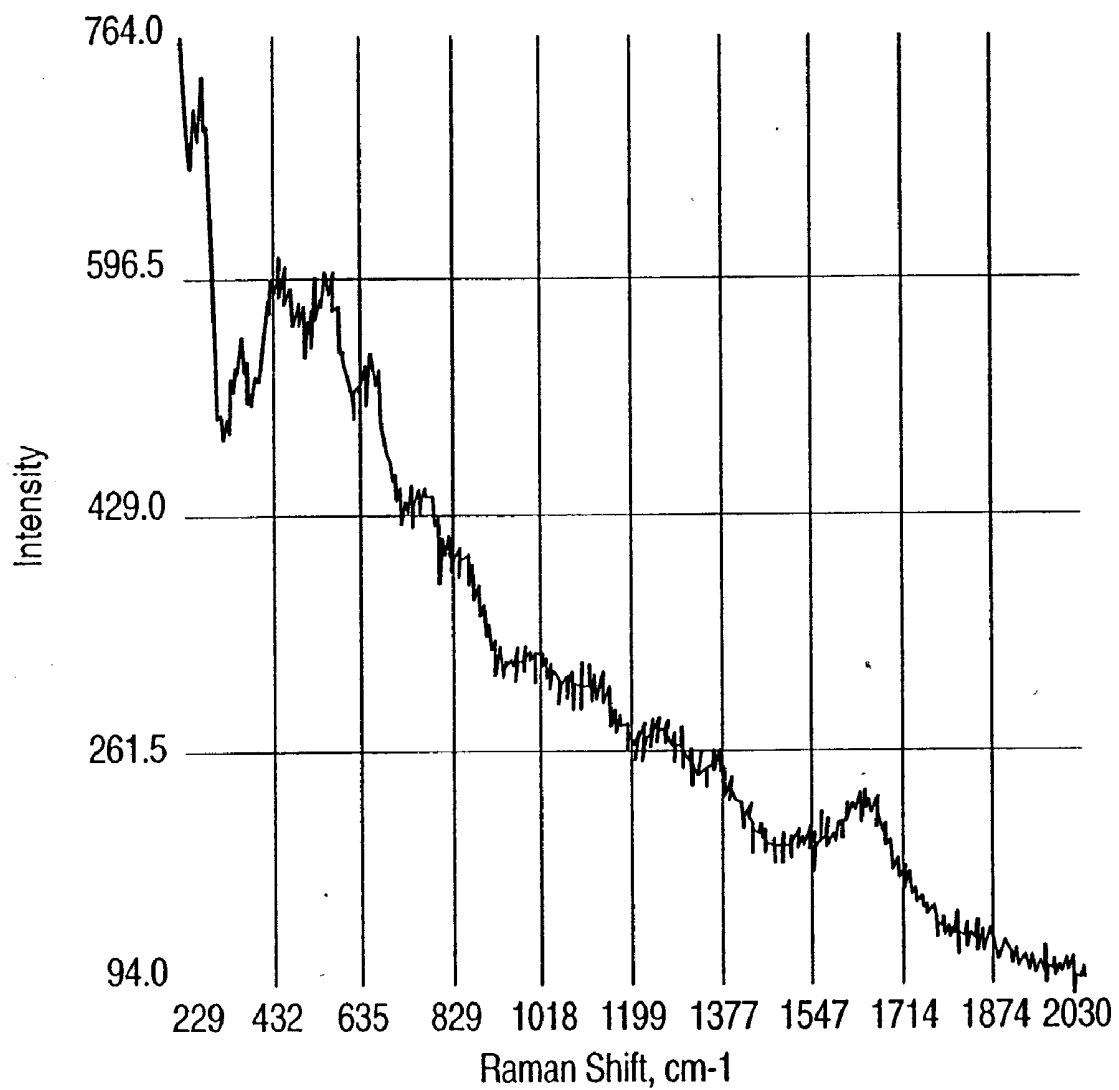

FIG. 17a

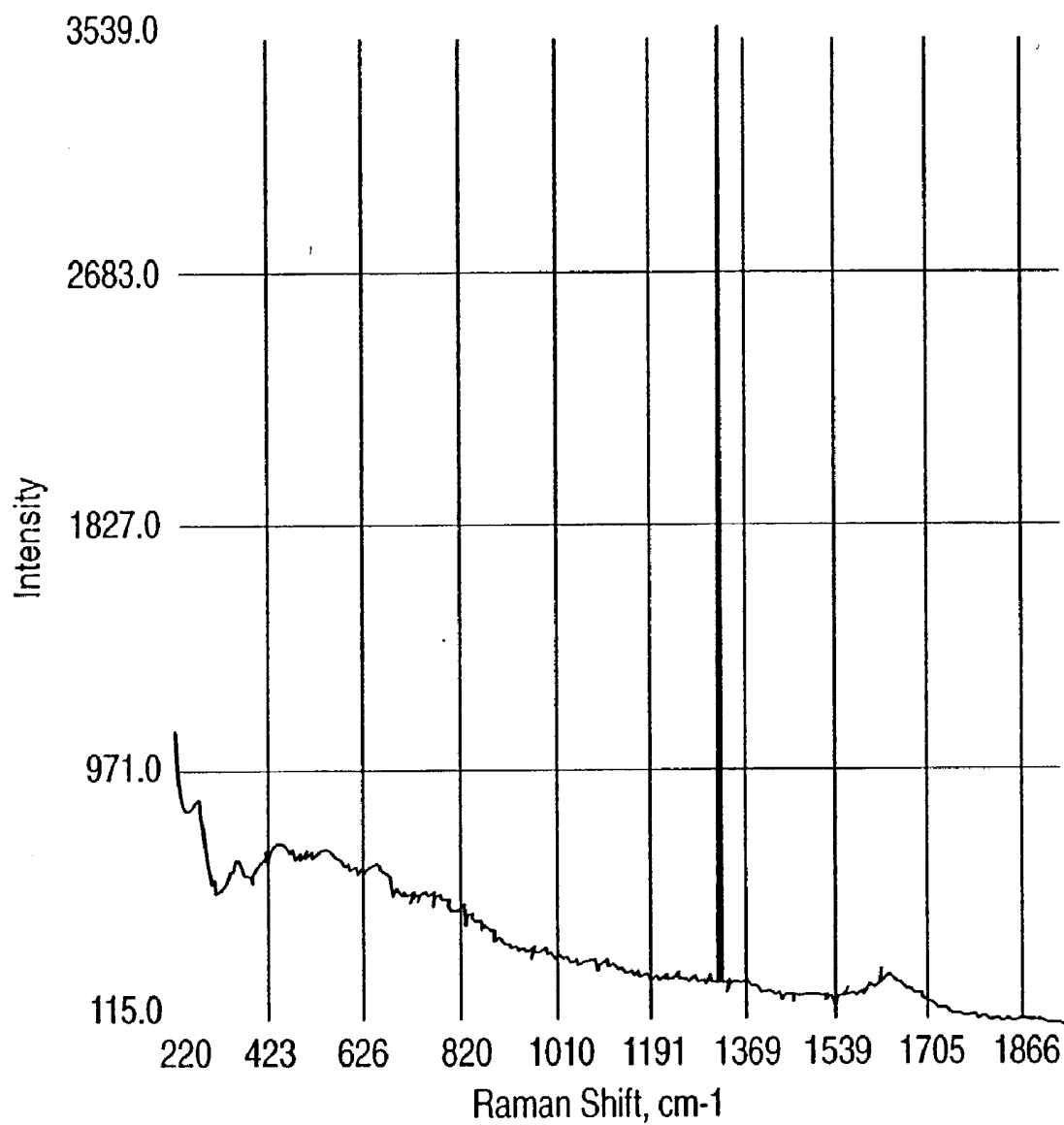

FIG. 17b

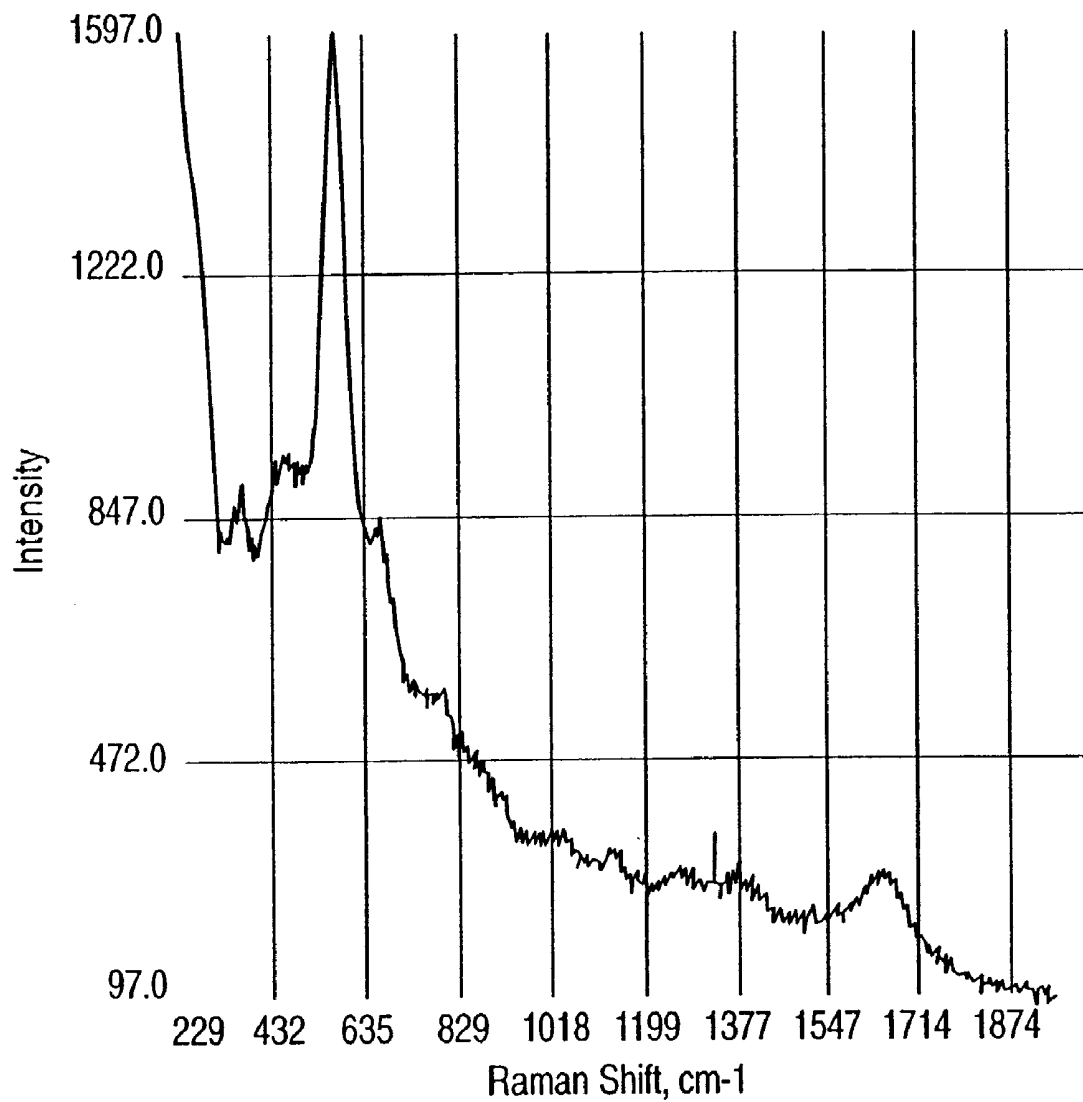
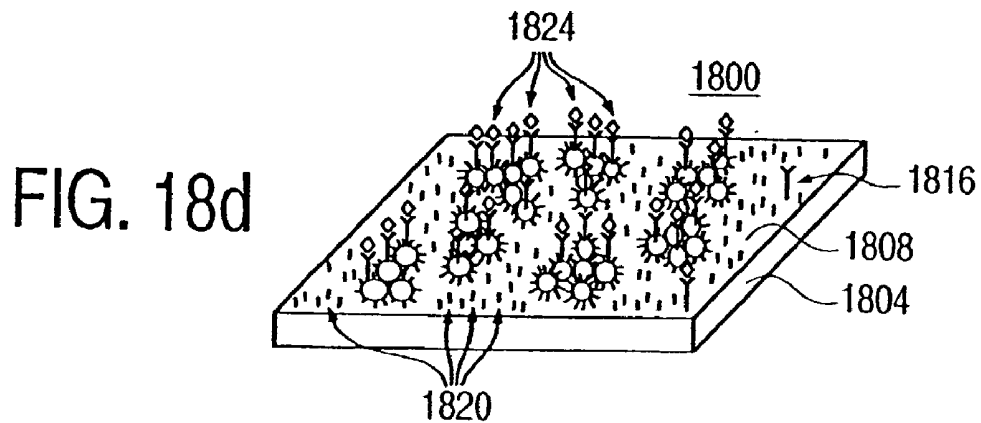
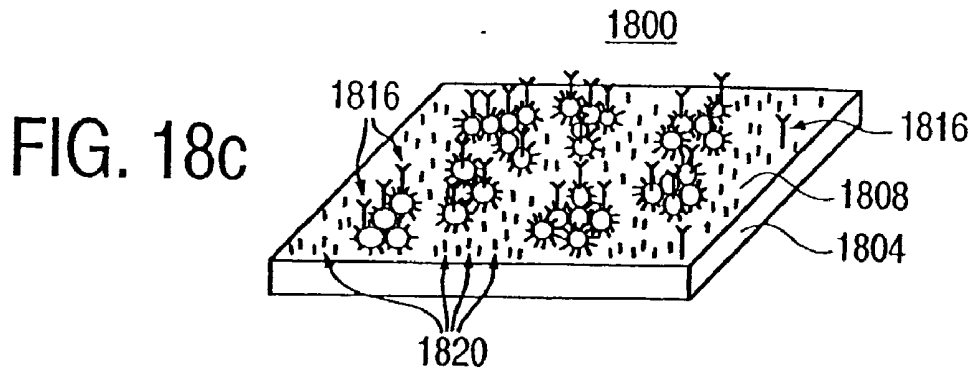
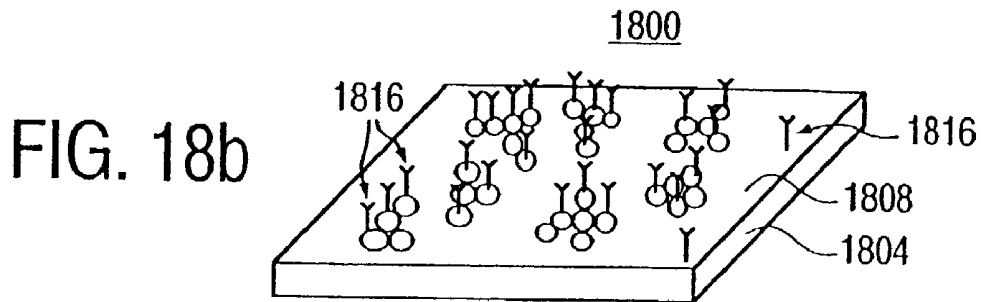
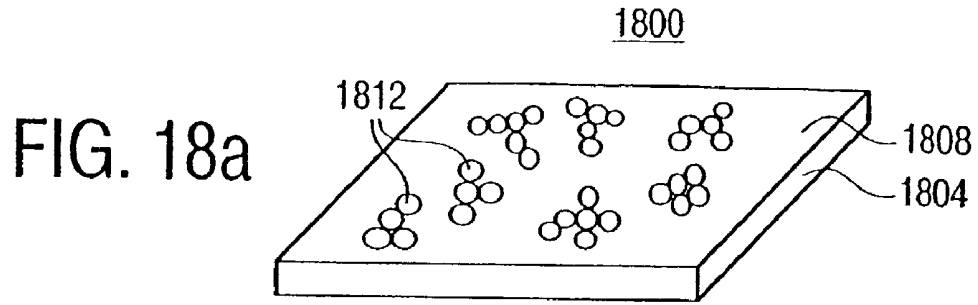
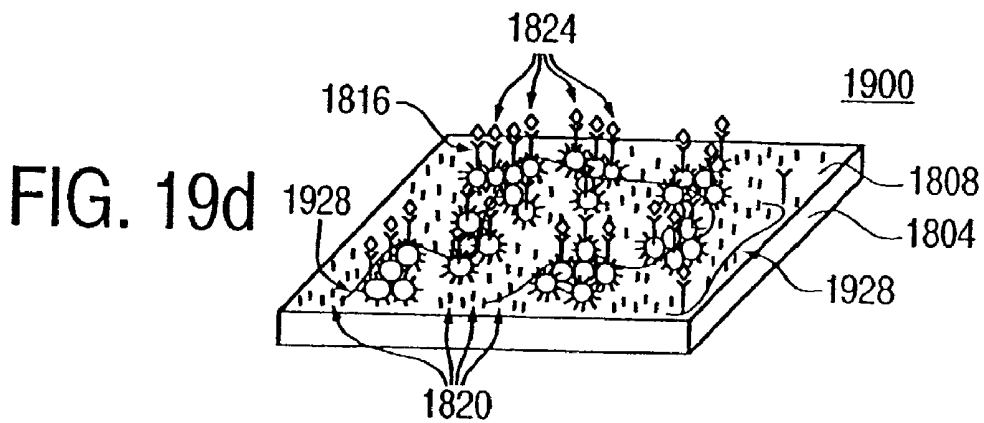
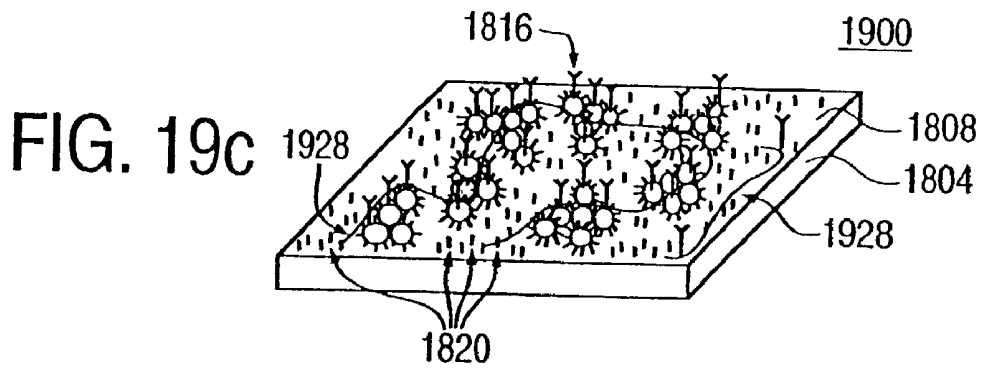
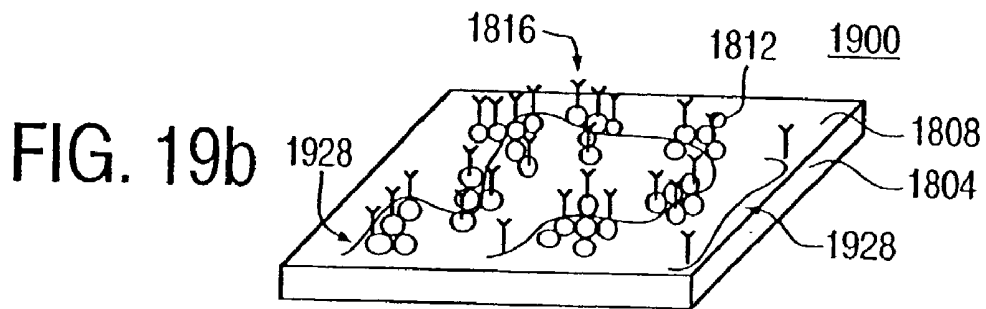
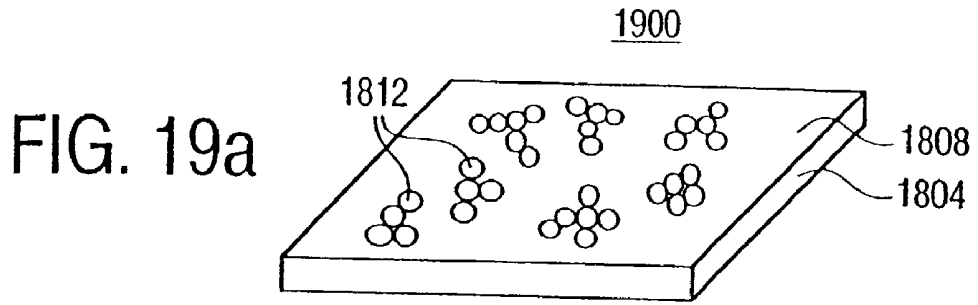

FIG. 17c





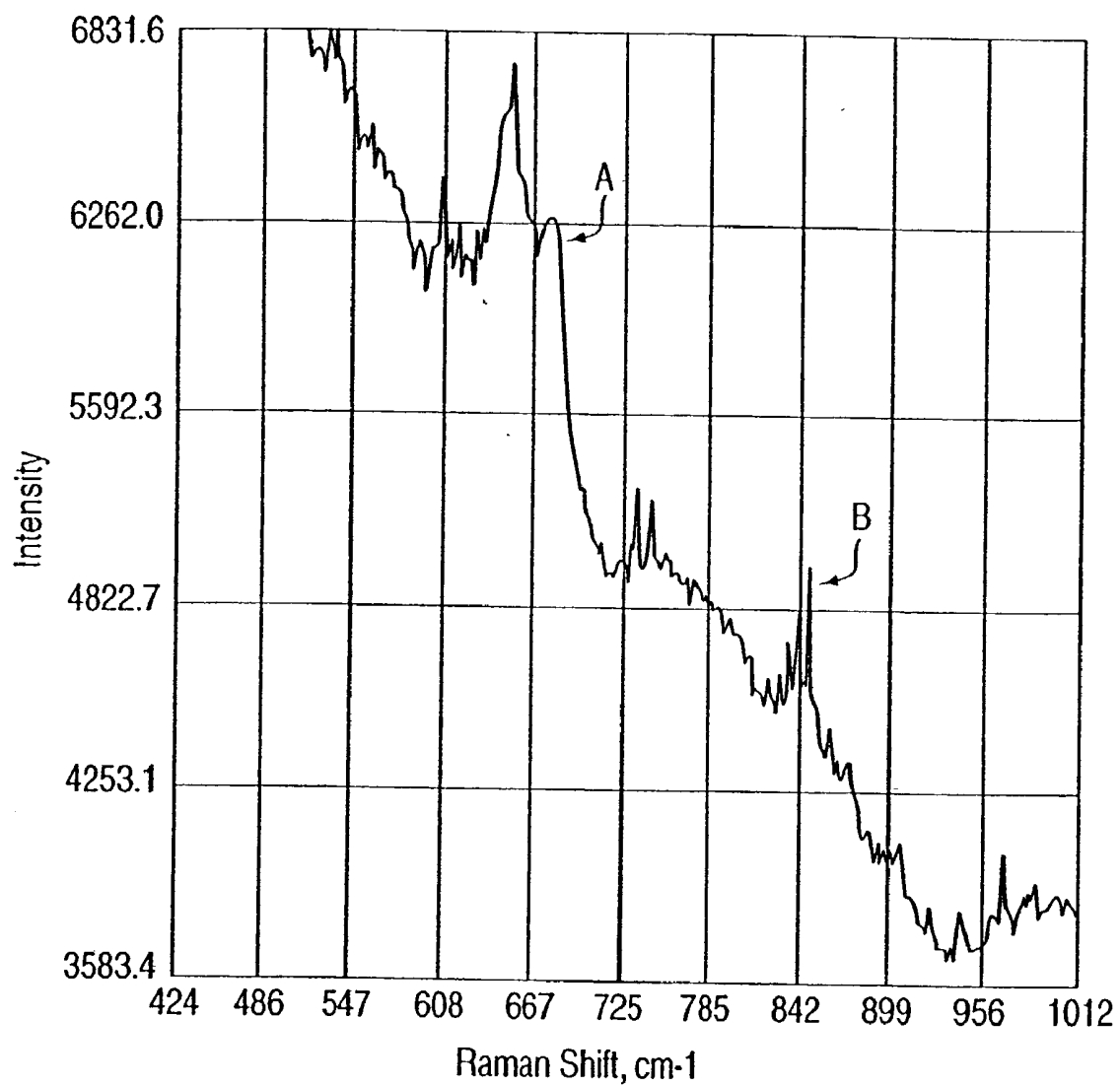

FIG. 20a

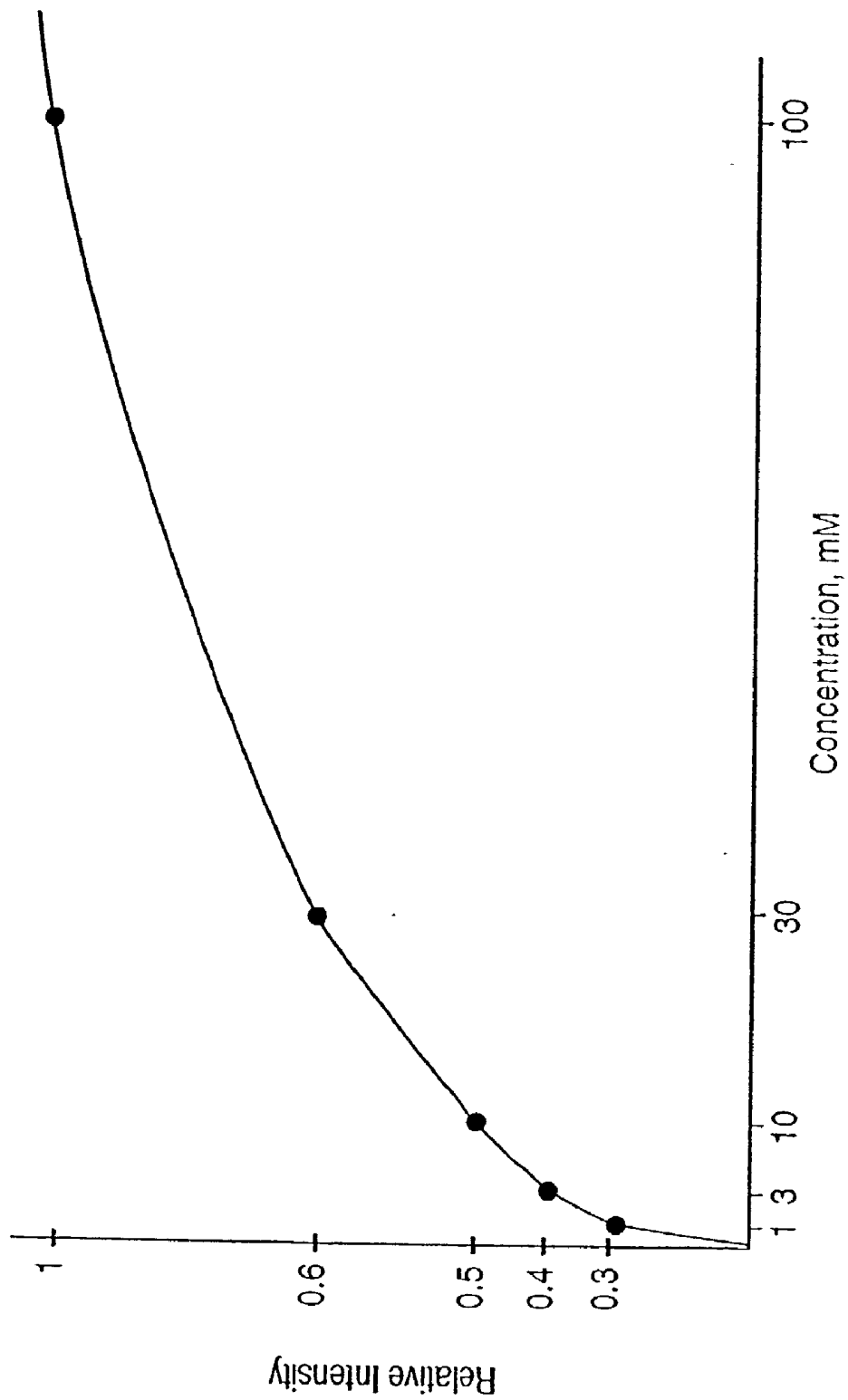

FIG. 20b

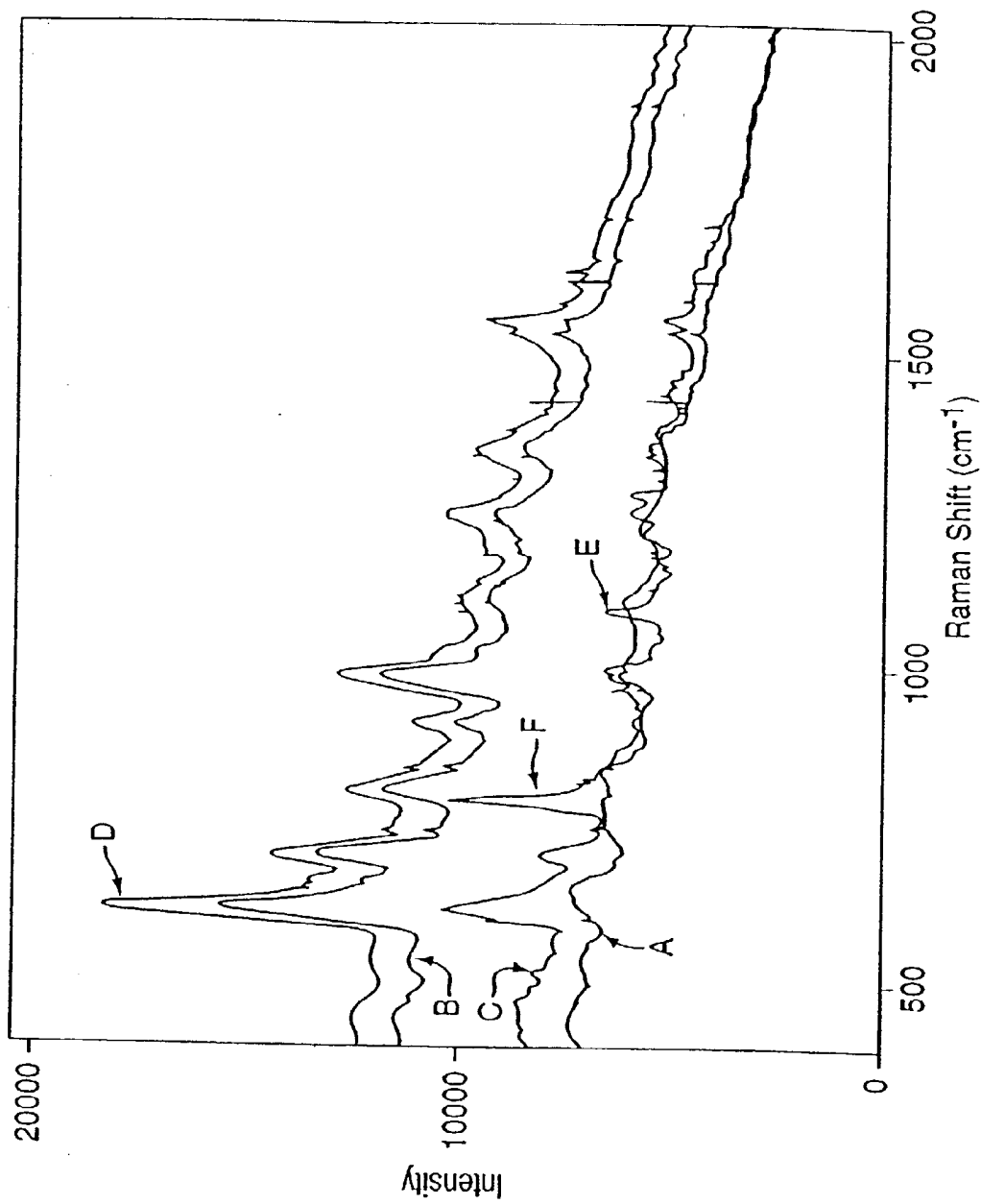

FIG. 21

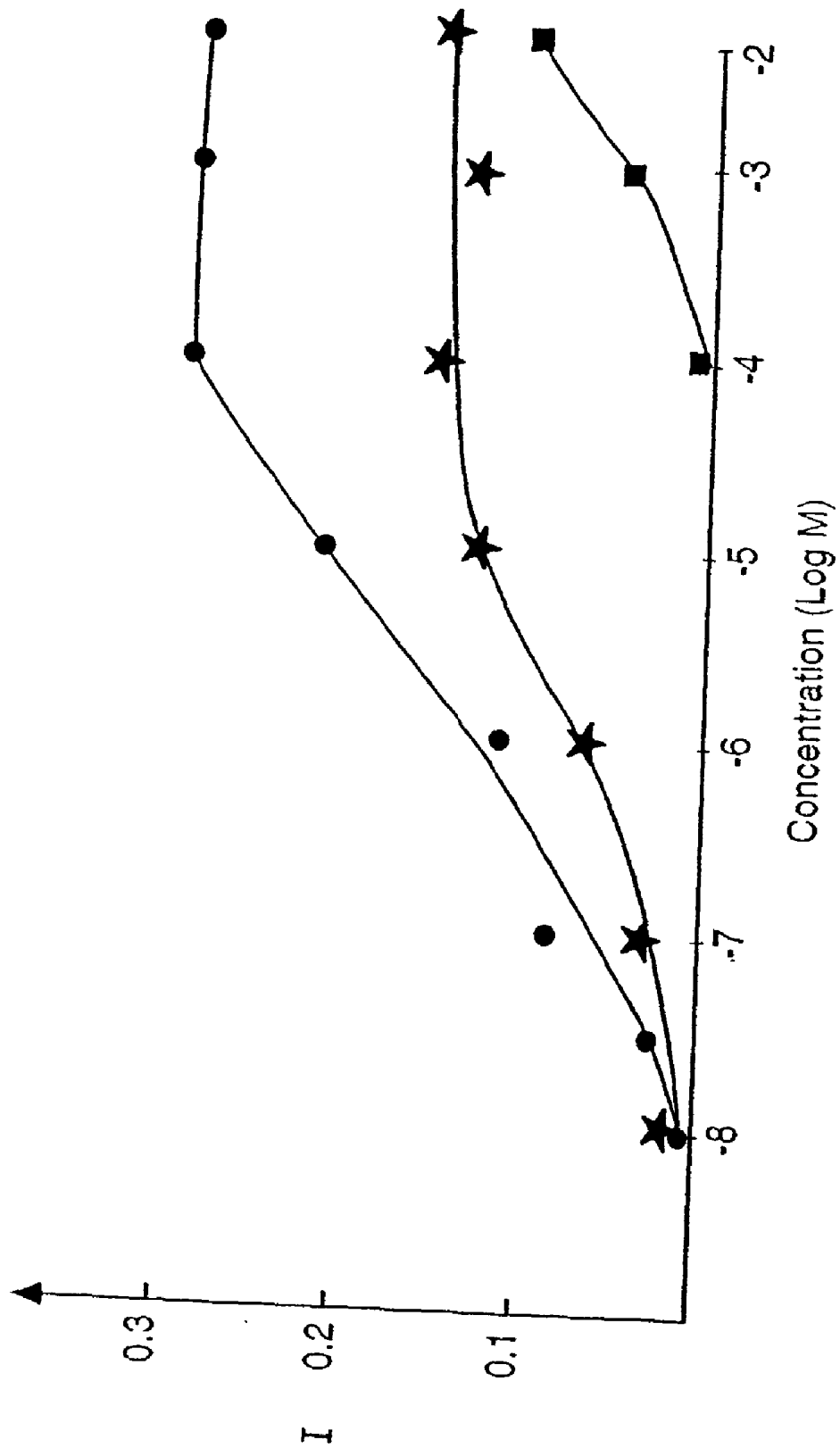

FIG. 22

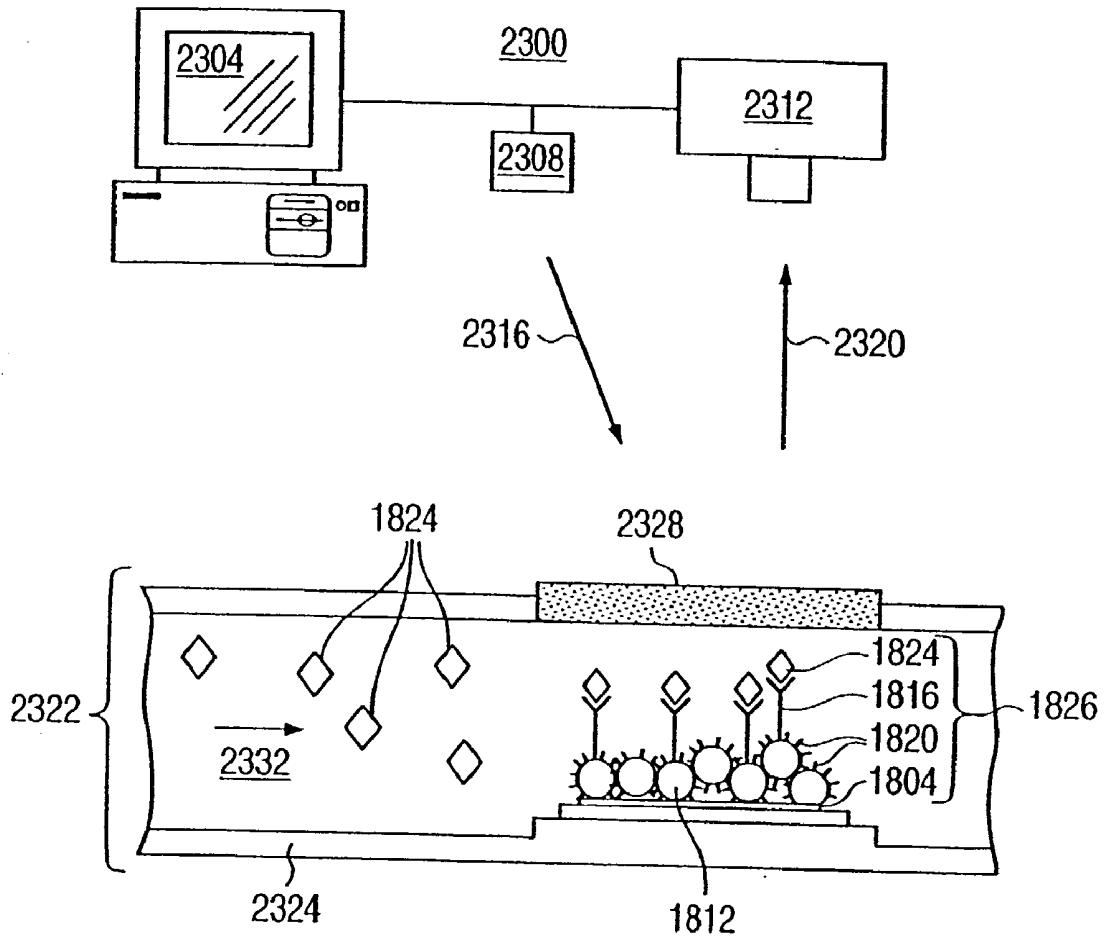

FIG. 23

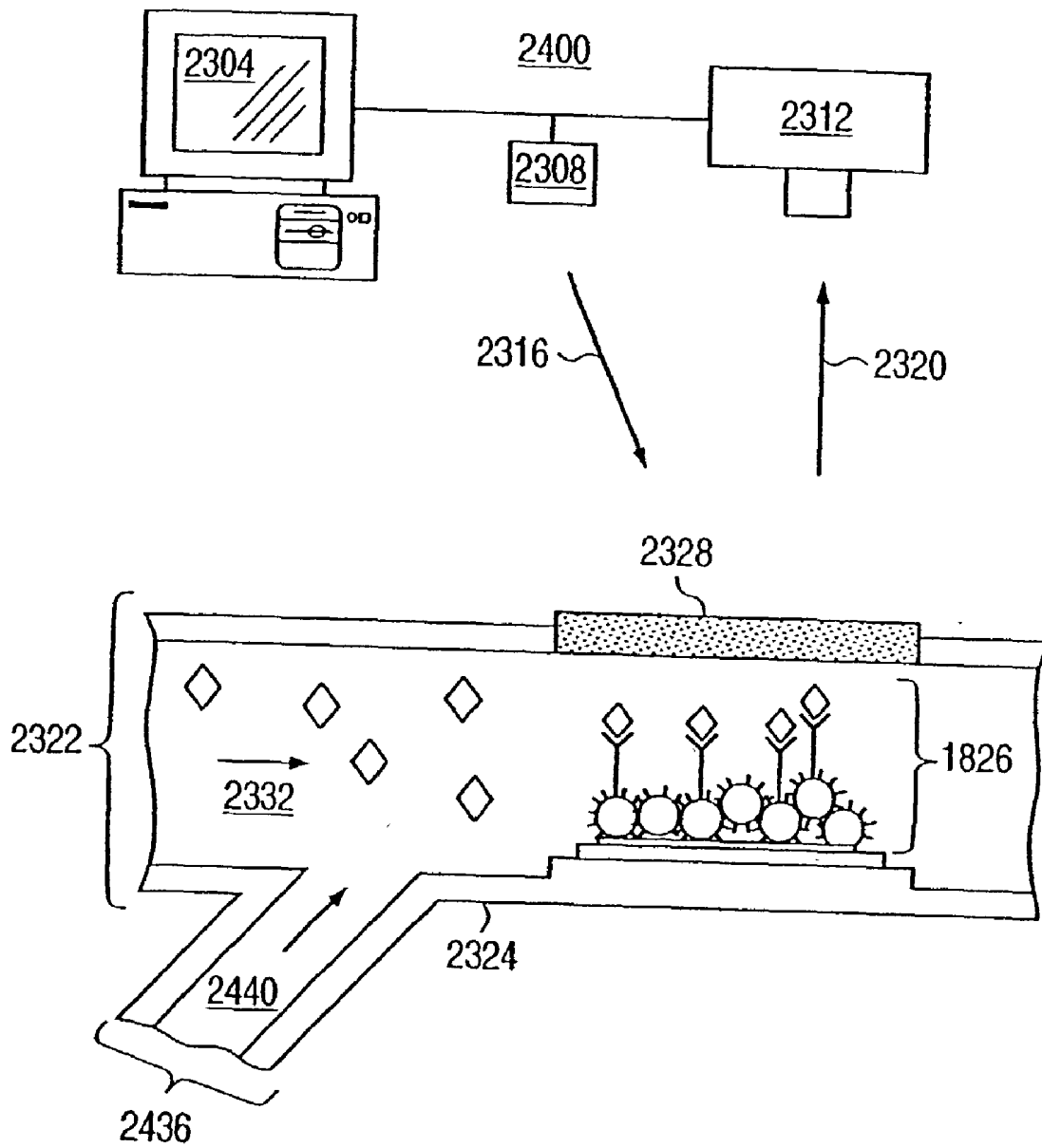

FIG. 24

BIOCHIPS FOR CHARACTERIZING BIOLOGICAL PROCESSES

RELATED APPLICATIONS

[0001] This application is a continuation-in-part of U.S. application Ser. No. 09/925,189, which is a continuation-in-part of U.S. application, Ser. No. 09/815,909 and U.S. application Ser. No. 09/670,453, filed Sep. 26, 2000, which claimed priority under 35 U.S.C. § 119 to U.S. Provisional Patent Application Serial No. 60/156,195, now abandoned. This application also claims priority to U.S. Provisional Patent Application Serial No. 60/336,445, filed Nov. 14, 2001. This application is related to U.S. patent application Ser. No. 09/669,369, filed Sep. 26, 2000, and U.S. patent application Ser. No. 09/669,796, filed Sep. 26, 2000. Each of these Patent Applications is herein incorporated fully by reference.

BACKGROUND OF THE INVENTION

[0002] 1. Field of the Invention

[0003] This invention relates to the manufacture and use of substrates having particle structures for analyte detection. Specifically, the invention relates to the manufacture and use of substrates having particle structures having receptor molecules attached to or near resonance domains within the particle structures. More specifically, the invention relates to the use of particle structures having receptor molecules for the detection of analytes characteristic of physiological and/or pathophysiological conditions using Raman spectroscopy.

[0004] 2. Description of Related Art

[0005] The detection and quantification of molecules or "analytes" in complex mixtures containing small amounts of analyte and large numbers and amounts of other materials is a continuing challenge. As more interest is focused upon the roles of biological molecules in physiology and disease processes, the rapid accurate detection of biological molecules such as nucleic acids and proteins is becoming more important.

[0006] I. Detection of Analytes

[0007] The detection of analyte, or "ligand" molecules is an important aspect of current biology, biotechnology, chemistry, and environmental industries. Detection of ligands can be accomplished using many different methods, including the chemical methods of chromatography, mass spectroscopy, nucleic acid hybridization and immunology. Hybridization and immunological methods rely upon the specific binding of ligands to detector, or "receptor" molecules. The basis for specificity of these methods is conferred by a receptor molecule can bind in a specific fashion to the ligand molecule, thereby creating a bound complex. Upon treating the complex under conditions that favor the removal of unbound ligand, the bound ligand can be assayed. The specificity of the binding, the completeness of separating bound and unbound ligands and receptors, and the sensitivity of the detection of the ligand confers the selectivity of the detection system.

[0008] For example, in biology and biotechnology industries, analytes such as deoxyribonucleic acid ("DNA") and messenger ribonucleic acid ("mRNA") are important indi-

cators of specific genetic, physiological or pathological conditions. DNA can contain important information about the genetic makeup of an organism, and mRNA can be an important indicator of which genes are active in a specific physiological or pathological condition and what proteins may be created as a result of gene activation. Additionally, the direct detection of proteins can be important to the understanding of the physiological or pathological condition of an individual.

[0009] DNA is made of a double helix of two strands, each of which is composed of a series or "sequence" of nucleotide bases. The bases found in DNA include adenine, thymine, cytosine and guanine. One strand of the double helix has a sequence of the nucleotides that can be transcribed into mRNA, herein termed a "reading strand," and the other strand has a sequence of bases, each of which is complementary to the base in the position corresponding in the reading strand. For every adenine in the reading strand, a thymine is present in the other strand. Similarly, for every cytosine in the reading strand, a guanine is present in the other strand. For every guanine and adenine in the reading strand, a cytosine and a thymine, respectively, is found in the other strand. Thus, when the two strands are aligned properly with respect to the other, the complementary bases of each strand can form hydrogen bonds, thereby holding the two strands in a complex, or "hybrid" according to the model of Watson and Crick ("Watson-Crick" hybridization). Thus, the two strands are considered herein to be "complementary" to each other. Ribonucleic acid has a similar structure as DNA, except that thymine is typically replaced by the base uracil. However, uracil is complementary to adenine, and thus, hybridization of RNA can occur with DNA. Because the information content of nucleic acids resides significantly in the sequence of the units that make up the nucleic acid, purely chemical methods that can detect only the presence of nucleotide bases are of limited usefulness. Thus, methods for detecting the presence of specific DNA or RNA relies upon the characterization of the sequence of bases of that nucleic acid.

[0010] A. Hybridization Detection of Nucleic Acids

[0011] Many different methods are currently in use for the detection of nucleic acids and proteins, but those methods can be time-consuming, expensive, or poorly reproducible. For example, the detection of specific nucleic acid sequences in DNA or RNA molecules can be accomplished using hybridization reactions, wherein an analyte DNA or RNA molecule is permitted to attach to a complementary sequence of DNA. A complementary DNA molecule can be attached to a supporting matrix, and the bound DNA and matrix is herein termed a "substrate." Exposing an analyte nucleic acid to a complementary substrate DNA can result in the formation of a relatively stable hybrid. Detection of the duplex DNA hybrid is characteristically carried out using methods that can detect labeled DNA analytes. The labeling is typically performed using radioactive, spin resonance, chromogenic or other labels, which are attached to the analyte molecules. Thus, when the labeled analyte attaches to the substrate, unbound analyte can be removed and the bound, or specific, analyte can be detected and quantified.

[0012] For example, to detect a mRNA molecule having a specific sequence using current methods, naturally occurring, or "native" mRNA is typically converted to a comple-

mentary DNA ("cDNA") molecule using an enzyme called "reverse transcriptase" under conditions that incorporate a labeled nucleotide into the cDNA. Upon binding of the labeled cDNA to the hybridization substrate, the bound ligand can be detected using a radiometric technique such as scintillation counting, fluorescence or spin resonance, depending on the type of label used.

[0013] Currently available methods for the detection of nucleic acids and proteins have undesirable characteristics. The methods are time consuming, require expensive equipment and reagents, require expert manual operations, and the reagents can be environmentally hazardous. Additionally, for assaying mRNA, the methods also can be sensitive to defects in the fidelity of reverse transcription. Unless the cDNA made during reverse transcription is exactly complementary to the mRNA, the analyte will not have the same sequence as the native mRNA, and misleading results can be obtained. The amplification of nucleic acid sequences by the polymerase chain reaction ("PCR") has been used to increase the numbers of nucleic acid molecules (complementary DNA or "cDNA") that can be detected. PCR requires DNA polymerase enzymes to amplify the cDNA. Some DNA polymerases can insert incorrect bases into a growing strand of newly synthesized cDNA. In addition, the recognition of ceratin cDNA by DNA polymerase and primers used for PCR can vary depending on the specific sequences of DNA in the sample to be amplified. This variation can result in non-proportional amplification of different cDNA molecules. Subsequent amplification of a strand having an incorrect sequence can result in the presence of several different cDNA sequences in the same sample. Thus, the accuracy and sensitivity of analysis of cDNA using PCR can be compromised.

[0014] Additionally, for medical diagnostic or forensic purposes, it can be very important for results of tests to be available rapidly. Commonly used methods for detection of specific nucleic acid sequences can be too slow for therapeutic or forensic uses. Thus, there is a need for rapid, accurate measurement of nucleic acid sequences.

[0015] II. Raman Spectroscopy

[0016] Raman spectroscopy involves the use of electromagnetic radiation to generate a signal in an analyte molecule. Raman spectroscopic methods have only recently been developed to the point where necessary sensitivity is possible. Raman spectroscopic methods and some ways of increasing the sensitivity of Raman spectroscopy are described herein below.

[0017] A. Raman Scattering

[0018] According to a theory of Raman scattering, when incident photons having wavelengths in the near infrared, visible or ultraviolet range illuminate a certain molecule, a photon of that incident light can be scattered by the molecule, thereby altering the vibrational state of the molecule to a higher or a lower level. The vibrational state of a molecule is characterized by a certain type of stretching, bending, or flexing of the molecular bonds. The molecule can then spontaneously return to its original vibrational state. When the molecule returns to its original vibrational state, it can emit a characteristic photon having the same wavelength as the incident photon. The photon can be emitted in any direction relative to the molecule. This phenomenon is termed "Raleigh Light Scattering."

[0019] A molecule having an altered vibrational state can return to a vibrational state different from the original state after emission of a photon. If a molecule returns to a state different from the original state, the emitted photon can have a wavelength different from that of the incident light. This type of emission is known as "Raman Scattering" named after C. V. Raman, the discoverer of this effect. If, a molecule returns to a higher vibrational level than the original vibrational state, the energy of the emitted photon will be lower (i.e., have longer wavelength) than the wavelength of the incident photon. This type of Raman scattering is termed "Stokes-shifted Raman scattering." Conversely, if a molecule is in a higher vibrational state, upon return to the original vibrational state, the emitted photon has a lower energy (i.e., have a shorter wavelength). This type of Raman scattering is termed "anti-Stokes-shifted Raman scattering." Because many more molecules are in the original state than in an elevated vibrational energy state, typically the Stokes-shifted Raman scattering will predominate over the anti-Stokes-shifted Raman scattering. As a result, the typical shifts of wavelength observed in Raman spectroscopy are to longer wavelengths. Both Stokes and anti-Stokes shifts can be quantified using a Raman spectrometer.

[0020] B. Resonance Raman Scattering

[0021] When the wavelength of the incident light is at or near the frequency of maximum absorption for that molecule, absorption of a photon can elevate both the electrical and vibrational states of the molecule. The efficiency of Raman scattering of these wavelengths can be increased by as much as about 10^8 times the efficiency of wavelengths substantially different from the wavelength of the absorption maximum. Therefore, upon emission of the photon with return to the ground electrical state, the intensity of Raman scattering can be increased by a similar factor.

[0022] C. Surface Enhanced Raman Scattering

[0023] When Raman active molecules are excited near to certain types of metal surfaces, a significant increase in the intensity of the Raman scattering can be observed. The increased Raman scattering observed at these wavelengths is herein termed "surface enhanced Raman scattering." The metal surfaces that exhibit the largest increase in Raman intensity comprise minute or nanoscale rough surfaces, typically coated with minute metal particles. For example, nanoscale particles such as metal colloids can increase intensity of Raman scattering to about 10^6 times or greater, than the intensity of Raman scattering in the absence of metal particles. This effect of increased intensity of Raman scattering is termed "surface enhanced Raman scattering."

[0024] The mechanism of surface enhanced Raman scattering is not known with certainty, but one factor can affect the enhancement. Electrons can typically exhibit a vibrational motion, termed herein "plasmon" vibration. Particles having diameters of about $\frac{1}{10}$ th the wavelength of the incident light can contribute to the effect. Incident photons can induce a field across the particles, and thereby can alter the movement of mobile electrons in the metal. As the incident light cycles through its wavelength, the induced motion of electrons can follow the light cycles, thereby creating an oscillation of the electron within the metal surface having the same frequency as the incident light. The electrons' motion can produce a mobile electrical dipole within the metal particle. When the metal particles have

certain configurations, incident light can cause groups of surface electrons to oscillate in a coordinated fashion, thereby causing constructive interference of the electrical field so generated, creating an area herein termed a "resonance domain." The enhanced electric field due to such resonance domains therefore can increase the intensity of Raman scattering and thereby can increase the intensity of the signal detected by a Raman spectrometer.

[0025] The combined effects of surface enhancement and resonance on Raman scattering is termed "surface enhanced resonance Raman scattering." The combined effect of surface enhanced resonance Raman scattering can increase the intensity of Raman scattering by about 10^{14} or more. It should be noted that the above theories for enhanced Raman scattering may not be the only theories to account for the effect. Other theories may account for the increased intensity of Raman scattering under these conditions.

[0026] D. Raman Methods for Detection of Nucleic Acids and Proteins

[0027] Several methods have been used for the detection of nucleic acids and proteins. Typically, an analyte molecule can have a reporter group added to it to increase the ability of an analytical method to detect that molecule. Reporter groups can be radioactive, fluorescent, spin labeled, and can be incorporated into the analyte during synthesis. For example, reporter groups can be introduced into cDNA made from mRNA by synthesizing the DNA from precursors containing the reporter groups of interest. Additionally, other types of labels, such as rhodamine or ethidium bromide can intercalate between strands of bound nucleic acids in the assay and serve as reporter groups of hybridized nucleic acid oligomers.

[0028] In addition to the above methods, several methods have been used to detect nucleic acids using Raman spectroscopy. Vo-Dinh, U.S. Pat. No. 5,814,516; Vo-Dinh, U.S. Pat. No. 5,783,389; Vo-Dinh, U.S. Pat. No. 5,721,102; Vo-Dinh, U.S. Pat. No. 5,306,403. These patents are herein incorporated fully by reference. Recently, Raman spectroscopy has been used to detect proteins. Tarcha et al., U.S. Pat. No. 5,266,498; Tarcha et al., U.S. Pat. No. 5,567,628, both incorporated herein fully by reference, provide an analyte that has been labeled using a Raman active label and an unlabeled analyte in the test mixture. The above-described methods rely upon the introduction of a Raman active label, or "reporter" group, into the analyte molecule. The reporter group is selected to provide a Raman signal that is used to detect and quantify the presence of the analyte.

[0029] By requiring reporter groups to be introduced into the analyte, additional steps and time are required. Additionally, the above methods can require extensive washing of the bound and unbound Raman labeled analytes to provide the selectivity and sensitivity of the assay. Moreover, because specific Raman labels must be provided for each type of assay system used, properties of the analytes must be determined in advance of the assay.

SUMMARY OF THE INVENTION

[0030] Thus, one object of this invention is the development of spectroscopic methods for detecting disease and physiological conditions.

[0031] These and other objects are met by the design and manufacture of substrates having receptors specific for

detection of sets of analytes, whose presence indicates a disease or physiological condition. In general, compositions useful for analyte detection of the present invention can use particle structures that are designed to enhance electromagnetic signals, including Raman signals. Particle structures may be fractal, random or ordered.

[0032] In certain embodiments of this invention, particle structures can be generated using chemical methods using linkers. Such linked particle structures can be designed and manufactured to have desired properties, including but not limited to selection of wavelengths of incident electromagnetic radiation that permit the generation of enhanced Raman signals to permit sensitive detection of a variety of analytes.

[0033] In certain embodiments of this invention, Raman and other electromagnetic signals can be detected for analytes without the need for incorporation of electromagnetically active labels into analyte molecules. Methods of these embodiments as used for Raman spectroscopic methods are herein termed "reverse Raman spectroscopy" or "RRS." Upon binding of the analyte to the receptor and removal of unbound analyte, the analyte can provide the detectable Raman signal for detection and/or quantification and/or identification. Thus, to detect nucleic acid sequences, oligonucleotide receptor molecules can be made that have sequences complementary to the specific sequences to be identified, but lack a typical component of the analyte molecule. By way of example only, adenine can be replaced by 2,6-di-aminopurine ("2,6 AP") without adversely affecting the binding of thymine residues in the analyte to the receptor molecule. Similarly, 5-methyluridine or 5(1-propynyl)uridine can replace thymine in a complementary nucleic acid sequence without adversely affecting the binding of adenine in an analyte. Moreover, in other embodiments of this invention, deuterium (D_2O) can be used to replace H_2O in certain synthesis of certain receptors. In yet other embodiments of this invention, peptide nucleic acids (herein termed "PNA") can be used in place of phosphate- and sugar-containing nucleic acids.

[0034] In other embodiments of this invention, detection of an analyte-receptor interaction is by observing an alteration in the Raman signal of the analyte receptor complex in the presence of enhancing structures compared to the Raman signals generated by enhancing structures and either the analyte or the receptor.

[0035] By using Raman systems as described, the binding of native molecules having the characteristic Raman signal can be detected and thereby can be easily quantified and analyzed. Therefore, these novel methods provide substantial improvements in speed, reliability and accuracy of the detection of biologically active molecules.

[0036] In other embodiments of this invention, surfaces are created that promote the surface enhancement effect of SERS. In other embodiments, Raman enhancing surfaces are made that incorporate receptors locally at resonance domains, thereby increasing the sensitivity of Raman spectroscopic detection.

[0037] In yet other embodiments of this invention, systems for analysis of biologically significant moieties are provided, wherein a particle structure, receptor and analyte are exposed to incident electromagnetic radiation, and the

Raman spectrum of the complexes are used to detect and/or quantify the amounts of analyte present.

[0038] In some embodiments, receptors can be attached to or placed near resonance domains, thereby concentrating the productive signal and increasing the sensitivity of detection of analytes.

[0039] Certain embodiments provide for the attachment of receptors to resonance domains selectively, thereby decreasing the effects of analyte-receptor complexes at other locations.

[0040] In yet further embodiments of this invention, fractal particle structures can be used to enhance a Raman signal generated in the presence of an analyte, thereby providing methods for detection of signals with increased sensitivity.

[0041] In other embodiments, this invention provides biochips for detecting one or more bioanalytes of relevance to determining the physiological or pathophysiological condition of an animal. Biochips and methods for their manufacture and use are provided to address insulin resistance, cellular oxidative stress, inflammation, apoptosis, cellular energetics and other biological processes. For each biological process for which biochips of this invention are provided, specific binding moieties, or receptors, specific for bioanalytes characteristic of the process are attached to a substrate having enhancing structures. For biological processes in which a plurality of bioanalytes are to be assayed, multiple receptor types can be attached to spatially arranged locations on the substrate, thereby forming an array of receptor types. Passivation agents may be used to increase the signal/noise ratio, increasing the accuracy and sensitivity of assays. A biological sample containing unlabeled bioanalytes of interest is applied to the biochip, and analytes bound to receptors can be detected using, for example, Raman spectroscopy. Methods for manufacturing and using biochips for characterizing biological processes are also provided.

[0042] Although many of the embodiments are illustrated for Raman spectroscopic detection of analytes, principles of this invention can be used for any detection system involving resonance of electromagnetic radiation, including fluorescence methods.

BRIEF DESCRIPTION OF THE DRAWINGS

[0043] The invention will be described with respect to the particular embodiments thereof. Other objects, features, and advantages of the invention will become apparent with reference to the specification and drawings in which:

[0044] FIG. 1 is a drawing depicting particle structures of this invention used for spectroscopy.

[0045] FIG. 2 depicts particle structures of this invention that has been subjected to photoaggregation.

[0046] FIGS. 3a-3c depict a strategy of this invention for chemically linking particles to form particle structures of this invention.

[0047] FIGS. 4a-4d depict a strategy of this invention for linking pairs of particle pairs together using linker molecules, and the manufacture of particle structures of this invention.

[0048] FIG. 5 depicts another embodiment of this invention in which the linker groups are comprised of aryl di-isocyanide groups.

[0049] FIGS. 6a-6e illustrates a photolithographic method for manufacturing particle structures of this invention.

[0050] FIGS. 7a-7b depicts particle structures of this invention as in FIG. 2 additionally having receptors. FIG. 7a depicts two particle structures of this invention having oligonucleotide receptor molecules comprising adenine residues ("A") attached to resonance domains. FIG. 7b depicts two particle structures of this invention having oligonucleotide receptor molecules, similar to that depicted in FIG. 7a, wherein the oligonucleotide receptor molecules comprises 2, 6-diaminopurine ("AP") residues substituted for adenine residues.

[0051] FIG. 8a depicts a portion of a particle structure of this invention having AP-substituted oligonucleotide receptors shown binding to thymine residues ("T") of analyte molecules. The analyte molecules have adenine residues ("A") that provide a Raman or other electromagnetic signal for detection.

[0052] FIG. 8b depicts a matrix of this invention, having defined areas thereon with particle structures within each area.

[0053] FIGS. 9a-9b are graphs illustrating the principle of this invention involving the use of an oligonucleotide receptor not having adenine in Raman spectroscopic detection of oligonucleic acids that contain adenine.

[0054] FIG. 9c is a graph showing the Raman spectrum of guanine.

[0055] FIGS. 10a-10c depict a methods for manufacturing nested particle structures of this invention. FIG. 10a depicts two particles having complementary oligonucleic acid sequences aligned to hold the particles in relationship with each other. FIG. 10b depicts a first-order nested particle structure of this invention. FIG. 10c depicts a second-order nested particle structure of this invention.

[0056] FIGS. 11a-11g depict methods for manufacturing biochips of this invention.

[0057] FIG. 11a depicts a substrate used for subsequent attachment of particle structures.

[0058] FIG. 11b depicts a substrate as in FIG. 11a having thiol groups.

[0059] FIG. 11c depicts particles of different sizes used to manufacture particle structures of this invention.

[0060] FIG. 11d depicts a group of nested particle structures of this invention.

[0061] FIG. 11e depicts a group of chemically linked particle structures of this invention.

[0062] FIG. 11f depicts a portion of a biochip of this invention having nested particle structures as in FIG. 11d attached to a substrate.

[0063] FIG. 11g depicts a portion of a biochip of this invention having chemically linked particle structures as in FIG. 11e attached to a substrate.

[0064] FIGS. 12a-12d depict embodiments of this invention having chemically linked particle structures and/or rods.

[0065] FIG. 12a depicts two rods useful for enhancement of electromagnetic signals.

[0066] FIG. 12b depicts a rod as shown in FIG. 12a having analyte receptors.

[0067] FIG. 12c depicts a portion of a biochip of this invention having rods with analyte receptors applied to a substrate.

[0068] FIG. 12d depicts a portion of a biochip of this invention having rods with receptors and chemically linked particles structures of this invention applied to a substrate.

[0069] FIGS. 13a-13b depict alternative embodiments of this invention. FIG. 13a depicts a top view of a portion of a biochip of this invention having rods/receptors aligned end-to-end and within channels inscribed in a substrate, with and without particles. FIG. 13b depicts a cross-sectional view through a portion of a biochip of this invention as described in FIG. 13a.

[0070] FIGS. 14a-14d depict the manufacture of a substrate of this invention having a gold surface, silver fractal structures, receptors, and analytes attached thereto.

[0071] FIGS. 15a-15b depict Raman spectra of preparations of fractal aggregates of this invention having reduced glutathione and glutathione S-transferase attached thereto.

[0072] FIGS. 16a-16g depict Raman spectral enhancement of DTP by fractal structures of this invention.

[0073] FIGS. 17a-17c depicts Raman spectra of rhodamine.

[0074] FIGS. 18a-18d depict embodiments of this invention having an enhancing surface, passivating agents and receptors.

[0075] FIGS. 19a-19d depict embodiments of this invention having an enhancing surface, a passivating agent and receptors attached to a polymer.

[0076] FIG. 20a depicts a Raman spectrum obtained for purine on a passivated fractal slide.

[0077] FIG. 20b depicts a graph of the relationship between concentration of purine on a passivated fractal slide as in FIG. 20a and the relative intensity of the Raman signal.

[0078] FIG. 21 depicts a graph of Raman shift versus intensity for a series of passivated substrates of this invention in the presence or absence of purine and/or purine receptor.

[0079] FIG. 22 depicts a graph of summary results for experiments in which passivated enhancing substrates have either purine or uracil thereon.

[0080] FIG. 23 depicts a schematic diagram of a flow-through device of this invention for measuring analytes.

[0081] FIG. 24 depicts an alternative embodiment of a flow-through device of this invention for measuring analytes.

DETAILED DESCRIPTION OF THE INVENTION

Definitions

[0082] The following words and terms are used herein.

[0083] The term “analyte” as used herein means molecules, particles or other material whose presence and/or

amount is to be determined. Examples of analytes include but are not limited to deoxyribonucleic acid (“DNA”), ribonucleic acid (“RNA”), amino acids, proteins, peptides, sugars, lipids, glycoproteins, cells, sub-cellular organelles, aggregations of cells, and other materials of biological interest.

[0084] The term “fractal” as used herein means a structure comprised of elements, and having a relationship between the scale of observation and the number of elements, i.e., scale-invariant. By way of illustration only, a continuous line is a 1-dimensional object. A plane is a two-dimensional object and a volume is a three-dimensional object. However, if a line has gaps therein, and is not a continuous line, the dimension is less than one. For example, if $\frac{1}{2}$ of the line is missing, then the fractal dimension is $\frac{1}{2}$. Similarly, if points on a plane are missing, the fractal dimension of the plane is between one and 2. If $\frac{1}{2}$ of the points on the plane are missing, the fractal dimension is 1.5. Moreover, if $\frac{1}{2}$ of the points of a solid are missing, the fractal dimension is 2.5. In scale invariant structures, the structure of objects appears to be similar, regardless of the size of the area observed. Thus, fractal structures are a type of ordered structures, as distinguished from random structures, which are not ordered.

[0085] The term “fractal associate” as used herein, means a structure of limited size, comprising at least about 100 individual particles associated together, and which demonstrates scale invariance within an area of observation limited on the lower bound by the size of the individual particles comprising the fractal associate and on the upper bound by the size of the fractal associate.

[0086] The term “fractal dimension” as used herein, means the exponent D of the following equation: $N \propto R^D$, where R is the area of observation, N is the number of particles, and D is the fractal dimension. Thus in a non-fractal solid, if the radius of observation increases by 2-fold, the number of particles observed within the volume increases by 2^3 . However, in a corresponding fractal, if the radius of observation increases by 2-fold, the number of particles observed increases by less than 2^3 .

[0087] The term “fractal-derivatized substrate as used herein means a substrate having fractal particle associates, fractal associates or enhancing structures thereon.

[0088] The term “fractal particle associates” as used herein means a large number of particles arranged so that the number of particles per unit volume (the dependent variable) or per surface unit changes non-linearly with the scale of observation (the independent variable).

[0089] The term “enhancing structure” as used herein means a structure that increases the amplitude of Raman signals generated by an analyte that is near the enhancing structure. The term enhancing structures includes fractal particle associates.

[0090] The term “label” as used herein means a moiety having a physicochemical characteristic distinct from that of other moieties that permit determination of the presence and/or amount of an analyte of which the label is a part. Examples of labels include but are not limited to fluorescence, spin-resonance, radioactive moieties. Also known as reporter group.

[0091] The term “linker” as used herein means an atom, molecule, moiety or molecular complex having two or more

chemical groups capable of binding to a surface and permitting the attachment of particles together to form groups of particles. The simplest linker connects two particles. A branched linker may link together larger numbers of particles.

[0092] The term “ordered structures” as used herein means structures that are non-random.

[0093] The term “particle structures” as used herein means a group of individual particles that are associated with each other in such a fashion as to permit enhancement of electric fields in response to incident electromagnetic radiation. Examples of particles include metals, metal-coated polymers and fullerenes. Also included in the meaning of the term “particle structures” are films or composites comprising particles on a dielectric surface or imbedded in a dielectric material.

[0094] The term “percolation point” as used herein means a point in time on a conductive surface or medium when the surface exhibits an increase in conductance, as measured either via surface or bulk conductance in the medium. One way to measure surface or “sheet” conductance is via electric probes applied to the surface.

[0095] The term “Raman array reader” as used herein means a device having a light source and a light detector.

[0096] The term “Raman signal” as used herein means a Raman spectrum or portion of Raman spectrum.

[0097] The term “Raman spectral feature” as used herein means a value obtained as a result of analysis of a Raman spectrum produced for an analyte under conditions of detection. Raman spectral features include, but are not limited to, Raman band frequency, Raman band intensity, Raman band width, a ratio of band widths, a ratio of band intensities, and/or combinations the above.

[0098] The term “Raman spectroscopy” as used herein means a method for determining the relationship between intensity of scattered electromagnetic radiation as a function of the frequency of that electromagnetic radiation.

[0099] The term “Raman spectrum” as used herein means the relationship between the intensity of scattered electromagnetic radiation as a function of the frequency of that radiation.

[0100] The term “random structures” as used herein means structures that are neither ordered nor fractal. Random structures appear uniform regardless of the point and scale of observation, wherein the scale of observation encompasses at least a few particles.

[0101] The term “receptor” as used herein means a moiety that can bind to or can retain an analyte under conditions of detection.

[0102] The term “resonance” as used herein means an interaction with either incident, scattered and/or emitted electromagnetic radiation and a surface having electrons that can be excited by the electromagnetic radiation and increase the strength of the electric field of the electromagnetic radiation.

[0103] The term “resonance domain” as used herein means an area within or in proximity to a particle structure in which an increase in the electric field of incident electromagnetic radiation occurs.

[0104] The term “reporter group” as used herein means label.

[0105] The term “reverse Raman spectroscopy” (“RRS”) as used herein means an application of Raman spectroscopy in which an analyte is distinguished by the presence of a Raman spectral feature that is not found in a receptor for that analyte or in the medium in which the analysis is performed.

[0106] The term “scaling diameter” as used herein means a relationship between particles in a nested structure, wherein there is a ratio (scaling ratio) of particle diameters that is the same, regardless of the size of the particles.

[0107] The term “surface enhanced Raman spectroscopy” (“SERS”) as used herein means an application of Raman spectroscopy in which intensity of Raman scattering is enhanced in the presence of an enhancing surface.

[0108] The term “surface enhanced resonance Raman spectroscopy” (“SERRS”) as used herein means an application of Raman spectroscopy in which Raman signals of an analyte are enhanced in the presence of an enhancing surface (see SERS) and when an absorption band of the analyte overlaps with the wavelength of incident electromagnetic radiation.

Embodiments of the Invention

[0109] The methods and compositions of this invention represent improvements over the existing methods for spectroscopic methods for detection and quantification of analyte molecules. In particular, the compositions and methods can be desirable for use in conjunction with infrared spectroscopy, fluorescence spectroscopy, surface plasmon resonance, Raman spectroscopy, mass spectroscopy or any other method utilizing excitation of an analyte by electromagnetic radiation.

[0110] Certain embodiments of this invention are based upon Surface Enhanced Raman Spectroscopy (“SERS”), Surface Enhanced Resonance Raman Spectroscopy (“SERRS”) and Reverse Raman Spectroscopy (“RRS”). This invention includes methods for manufacturing Raman active structures having specific analyte receptor molecules attached to those structures. The invention also includes methods for detecting analytes using Raman spectroscopy, reverse Raman spectroscopy, compositions useful for reverse Raman spectroscopy, and arrays and test kits embodying Raman spectroscopic methods.

[0111] The structures that are desirable for use according to the methods of this invention include structures of small particles in structures, herein termed particle structures, which includes as a subset, fractal associates. Particle structures can be characterized by having physical and chemical structures that enable oscillations of electrons to be in resonance with incident and outgoing electromagnetic radiation.

[0112] I. Manufacture of Particle Structures

[0113] The Raman active structures desirable for use according to this invention can include any structure in which Raman signals can be amplified. The following discussion regarding metal fractal structures is not intended to be limiting to the scope of the invention, but is for purposes of illustration only.

[0114] A. Manufacture of Metal Particles

[0115] To make metal particles for nanoscale arrays of receptors according to some embodiments of this invention, we can generally use methods known in the art. Tarcha et al., U.S. Pat. No. 5,567,628, incorporated herein fully by reference. Metal colloids can be composed of noble metals, specifically, elemental gold or silver, copper, platinum, palladium and other metals known to provide surface enhancement. In general, to make a metal colloid, a dilute solution containing the metal salt is chemically reacted with a reducing agent. Reducing agents can include ascorbate, citrate, borohydride, hydrogen gas, and the like. Chemical reduction of the metal salt can produce elemental metal in solution, which combine to form a colloidal solution containing metal particles that are relatively spherical in shape.

EXAMPLE 1

Manufacture of Gold Colloid and Fractal Structures

[0116] In one embodiment of this invention, a solution of gold nuclei is made by preparing a 0.01% solution of NaAuCl_4 in water under vigorous stirring. One milliliter ("mL") of a solution of 1% sodium citrate is added. After 1 minute of mixing, 1 mL of a solution containing 0.075% NaBH_4 and 1% sodium citrate is added under vigorous stirring. The reaction is permitted to proceed for 5 minutes to prepare the gold nuclei having an average diameter of about 2 nm). The solution containing the gold nuclei can be refrigerated at 4° C. until needed. This solution can be used as is, or can be used to produce particles of larger size (e.g., up to about 50 nm diameter), by rapidly adding 30 μl of the solution containing gold nuclei and 0.4 mL of a 1% sodium citrate solution to the solution of 1% $\text{HAuCl}_4 \cdot 3\text{H}_2\text{O}$ diluted in 100 mL H_2O , under vigorous stirring. The mixture is boiled for 15 minutes and is then cooled to room temperature. During cooling, the particles in the solution can form fractal structures. The resulting colloid and/or fractal particle structures can be stored in a dark bottle.

[0117] Deposition of enhancing particles on dielectric surfaces including glass can generate films that can enhance electromagnetic signals. Such films can be as thin as about 10 nm. In particular, the distribution of electric field enhancement on the surface of such a film can be uneven. Such enhancing areas are resonance domains. Such areas can be particularly useful for positioning receptors for analyte binding and detection. For films or particle structures embedded in dielectric materials, one way to manufacture enhancing structures is to treat the surface until "percolation points" appear. Methods for measuring sheet resistance and bulk resistance are well known in the art.

EXAMPLE 2

Manufacture of Metal Particles and Fractal Structures Using Laser Ablation

[0118] In addition to liquid phase synthesis described above, laser ablation is used to make metal particles. A piece of metal foil is placed in a chamber containing a low concentration of a noble gas such as helium, neon, argon, xenon, or krypton. Exposure to the foil to laser light or other heat source causes evaporation of the metal atoms, which, in suspension in the chamber, can spontaneously aggregate to

form fractal or other particle structures as a result of random diffusion. These methods are well known in the art.

[0119] B. Manufacture of Films Containing Particles

[0120] To manufacture substrates containing metal colloidal particles of one embodiment of this invention, the colloidal metal particles can be deposited onto quartz slides as described in Examples 1 or 2. Other films can be made that incorporate random structures or non-fractal ordered structures in similar fashions.

EXAMPLE 3

Manufacture of Quartz Slides Containing Gold Fractal Structures

[0121] Quartz slides (2.5 cm×0.8 cm×0.1 cm) are cleaned in a mixture of $\text{HCl}:\text{HNO}_3$ (3:1) for several hours. The slides are then rinsed with deionized H_2O (Millipore Corporation) to a resistance of about 18 M Ω and then with CH_3OH . Slides are then immersed for 18 hours in a solution of aminopropyltrimethoxysilane diluted 1:5 in CH_3OH . The slides are then rinsed extensively with CH_3OH (spectrophotometric grade) and deionized H_2O prior to immersion into colloidal gold solution described above. The slides are then immersed in the gold colloid solution above. During this time, the gold colloid particles can deposit and can become attached to the surface of the quartz slide. After 24 hours, colloid derivatization is complete. Once attached, the binding of colloidal gold nanocomposites to the quartz surfaces is strong and is essentially irreversible. During the procedure, ultraviolet and/or visual light absorbance spectra of such derivatized slides are used to assess the quality and reproducibility of the derivatization procedure. The manufacturing process is monitored using electron microscopy to assess the density of the colloidal coating, the distribution of gold colloid particles on the surface, and the size of the gold colloid particles.

[0122] In other embodiments, fractal aggregates can be attached to substrates having a layer of gold metal thereon. The types of substrates are not limited, and can be quartz, conventional glass, plastic or any other substrate upon which a layer of gold metal can adhere. Because gold metal is relatively chemically inert, once prepared, the gold-coated slides can be cleaned using conventional methods prior to attachment of fractal aggregates thereto. Gold or silver fractal aggregates can be prepared using methods described herein or using methods from the prior art. Colloidal or fractal aggregates can then be applied to the surface of the gold-coated substrate and the fractal aggregates tend to adhere to the gold surface, forming a fractal-derivatized or colloidal derivatized substrate.

[0123] After attachment of fractal aggregates to the gold surface of the substrate, the fractal-derivatized substrate can be washed to remove unbound colloids. For example, for gold fractal aggregates, it can be desirable to wash the substrate with a solution containing an acid. In certain embodiments, it can be desirable to use nitric acid, and in other embodiments, it can be desirable to use concentrated nitric acid for a period of several hours at a temperature above the freezing point of the acid solution, up to the melting temperature of the fractal aggregates. In other embodiments, other acids can be used, such as HCl , sulfuric acid, acetic acid or other acid. Furthermore the conditions of

the washing can be determined by methods known in the art. In certain embodiments, it can be desirable to use a mixture of an acid and an organic solvent, such as acetone to remove materials soluble in such solvents. The types of acids and organic solvents can be selected depending on the types of reagents or contaminants present in the solutions used to prepare the fractal aggregates.

[0124] C. Aggregation of Particles to Form Particle Structures

[0125] According to other embodiments of this invention, several methods can be used to form particle structures. It is known that metal colloids can be deposited onto surfaces, and when aggregated can form fractal structures having a fractal dimension of about 1.8. Safonov et al., *Spectral Dependence of Selective Photomodification in Fractal Aggregates of Colloidal Particles*, *Physical Review Letters* 80(5):1102-1105 (1998) incorporated herein fully by reference. **FIG. 1** depicts a particle structure suitable for use with the methods of this invention. The particles are arranged in a scale-invariant fashion, which promotes the formation of resonance domains upon illumination by laser light.

[0126] In addition to fractal structures, ordered non-fractal structures and random structures can be generated. These different types of structures can have desirable properties for enhancing signals associated with detection of analytes using electromagnetic radiation.

[0127] To make ordered non-fractal structures, one can use, for example, chemical linkers having different lengths sequentially as described in more detail below. In addition, using linkers of the same size, one can generate ordered structures, which can be useful for certain applications.

[0128] In certain embodiments of this invention, particles can be attached together to form structures having resonance properties. In general, it can be desirable to have the particles being spheres, ellipsoids, or rods. For ellipsoidal particles, it can be desirable for the particles to have a long axis (x), another axis (y) and a third axis (z). In general, it can be desirable to have x be from about 0.05 to about 1 times the wavelength (λ) of the incident electromagnetic radiation to be used. For rods, it can be desirable for x to be less than about 4λ , alternatively, less than about 3λ , alternatively less than about 2λ , in other embodiments, less than about 1λ , and in yet other embodiments, less than about $\frac{1}{2}\lambda$. The ends of the rods can be either flat, tapered, oblong, or have other shape that can promote resonance.

[0129] For two particle structures, it can be desirable for the particle pair to have an x dimension to be less than about 4λ , alternatively, less than about 3λ , alternatively less than about 2λ , in other embodiments, less than about 1λ , and in yet other embodiments, less than about $\frac{1}{2}\lambda$.

[0130] For two-dimensional structures, pairs of particles, rods, rods plus particles together can be used. The arrangement of these elements can be randomly distributed, or can have a distribution density that is dependent upon the scale of observation in a non-linear fashion.

[0131] In other embodiments, rods can be linked together end-to-end to form long structures that can provide enhanced resonance properties.

[0132] For three-dimensional structures, one can use regular nested particles, or chemical arrays of particles, associated either by chemical linkers in a fractal structure or in ordered, nested arrays.

[0133] In yet other embodiments, of third-order structures, a suspension of particles can be desirable. In certain of these embodiments, the suspended particles can have dimensions in the range of about $\frac{1}{2}\lambda$ to about 1 millimeter (mm).

[0134] Using the strategies of this invention, a researcher or developer can satisfy many needs, including, but not limited to selecting the absorbance of electromagnetic radiation by particle elements, the nature of the surface selected, the number of resonance domains, the resonance properties, the wavelengths of electromagnetic radiation showing resonance enhancement, the porosity of the particle structures, and the overall structure of the particle structures, including, but not limited to the fractal dimensions of the structure(s).

[0135] 1. Photoaggregation

[0136] Photoaggregation can be used to generate particle structures that have properties which can be desirable for use in Raman spectroscopy.

[0137] Irradiation of fractal metal nanocomposites by a laser pulse with an energy above a certain threshold leads to selective photomodification, a process that can result in the formation of "dichroic holes" in the absorption spectrum near the laser wavelength (Safonov et al., *Physical Review Letters* 80(5):1102-1105 (1998), incorporated herein fully by reference). Selective photomodification of the geometrical structure can be observed for both silver and gold colloids, polymers doped with metal aggregates, and films produced by laser evaporation of metal targets.

[0138] One theory for the formation of selective photomodification is that the localization of optical excitations in fractal structures are prevalent in random nanocomposites. According to this theory, the localization of selective photomodification in fractals can arise because of the scale-invariant distribution of highly polarizable particles (monomers). As a result, small groups of particles having different local configurations can interact with the incident light independently of one another, and can resonate at different frequencies, generating different domains, called herein "optical modes." According to the same theory, optical modes formed by the interactions between monomers in fractal are localized in domains that can be smaller than the optical wavelength of the incident light and smaller than the size of the clusters of particles in the colloid. The frequencies of the optical modes can span a spectral range broader than the absorption bandwidth of the monomers associated with plasmon resonance at the surface. However, other theories may account for the effects of photomodification of fractal structures, and this invention is not limited to any particular theory for operability.

[0139] Photomodification of silver fractal aggregates can occur within domains as small as about $24 \times 24 \times 48 \text{ nm}^3$ (Safonov et al., *Physical Review Letters* 80(5):1102-1105 (1998), incorporated herein fully by reference). The energy absorbed by the fractal medium can be localized in a progressively smaller number of monomers as the laser wavelength is increased. As the energy absorbed into the resonant domains increases, the temperature at those locations can increase. At a power of 11 mJ/cm^2 , light having a wavelength of 550 nm can produce a temperature of about 600 K (Safonov et al., *Physical Review Letters* 80(5):1102-1105 (1998), incorporated herein fully by reference). At this temperature, which is about one-half the melting tempera-

ture of silver, sintering of the colloids can occur (Safonov et al., Id.) incorporated herein fully by reference), thereby forming stable fractal nanocomposites.

[0140] As used in this invention, photoaggregation can be accomplished by exposing a metal colloid on a surface to pulses of incident light having a wavelength in the range of about 400 nm to about 2000 nm. In alternative embodiments, the wavelength can be in the range of about 450 nm to about 1079 nm. The intensity of the incident light can be in the range of about 5 mJ/cm² to about 20 mJ/cm². In an alternative embodiment, the incident light can have a wavelength of 1079 nm at an intensity of 11 mJ/cm².

[0141] Fractal aggregates that are especially useful for the present invention can be made from metal particles having dimensions in the range of about 10 nm to about 100 nm in diameter, and in alternative embodiments, about 50 nm in diameter. A typical fractal structure of this invention is composed of up to about 1000 particles, and an area of the aggregate typically used for large-scale arrays can have a size of about 100 μm×100 μm.

[0142] FIG. 2 depicts a particle structure that have been photoaggregated and that are suitable for use with the methods of this invention. Local areas of fusion of the metal particles can be observed (circles).

[0143] 2. Chemically Directed Synthesis of Particle Structures

[0144] In certain embodiments of this invention, particle structures can be made using chemical methods. First, metal particles can be either made according to methods described above, or alternatively can be purchased from commercial suppliers (NanoGram Inc., Fremont, Calif.). Second, the particles can be joined together to form first-order structures, for example, pairs of particles. Then, the first-order structures can be joined together to form second-order structures, for example, pairs of particle pairs. Finally, third-order fractal structures can be made by joining second-order structures together.

[0145] In alternative embodiments of this invention, the formation of a fractal array of metal particles can be carried out using chemical methods. Once metal colloid particles have been manufactured, each particle can be attached to a linker molecule via a thiol or other type of suitable chemical bond. The linker molecules then can be attached to one another to link adjacent colloid particles together. The distance between the particles is a function of the total lengths of the linker molecules. It can be desired to select a stoichiometric ratio of particles to linker molecules. If too few linker molecules are used, then the array of particles will be too loose or may not form at all. Conversely, if the ratio of linker molecules to particles is too high, the array may become too tight, and may even tend to form crystalline structures, which are not random, and therefore will not tend to promote surface enhanced Raman scattering.

[0146] In general, it can be desirable to perform the linking procedure sequentially, wherein the first step comprises adding linker molecules to individual particles under conditions that do not permit cross-linking of particles together. By way of example only, such a linker can comprise an oligonucleotide having a reactive group at one end only. During this first step, the reactive end of the oligonucleotide can bind with a metal particle, thereby forming a

first particle-linker species, and having a free end of the linker. The ratio of linker molecules to particles can be selected, depending on the number of linker molecules are to be attached to the particle. A second linker can be attached to another group of particles in a different reaction chamber, thereby resulting in a second linker-particle species, again with the linker having a free end.

[0147] After those reactions have progressed, the different linker-particle species can be mixed together and the linkers can attach together to form "particle pairs" joined by the linker molecules.

[0148] By way of example, FIGS. 3a to 3c illustrates methods for manufacturing fractal structures of this invention. In FIG. 3a, metal particles 10 are formed using methods previously described. Short linkers 20 have chemically active ends that are capable of binding to metal particles 10. For example, linker 20 has sulfhydryl ("SH") groups at each end of the linker 20. When combined, metal particles 10 bind with the SH ends of linkers 20 to form particle pairs 30.

[0149] FIG. 3b illustrates the steps that can be used to form clusters of particle pairs. Particle pairs 30 are reacted with medium-length linkers 40 to form clusters 50.

[0150] FIG. 3c illustrates the steps that can be used to form nanoscale fractal structures of this invention. Clusters 50 are reacted with long linkers 60 to form nanoscale fractal structure 70.

[0151] In other embodiments, nucleic acids can be used as linkers, based upon the ability of DNA to form hybrids with nucleic acids comprising complementary sequences. DNA ligases or other mechanisms can be used to join the linkers together to form a complete linker between metal particles.

[0152] FIG. 4 depicts, in general, the linkage of metal particles to form particle pairs using linkers having binding domains. FIG. 4a depicts two metal particles (M), each having a linker molecule (L1 or L2) having a desired length, comprising inter-linker binding domains (BD1 and BD2). The inter-linker binding domains are unbound. FIG. 4b depicts the particles shown in FIG. 4a after binding of the inter-linker binding domains to form a particle pair. In embodiments in which the linkers are nucleic acids, the binding domains can have complementary sequences, such that the nucleotide residues can form stable hybrid complexes with each other, thereby linking the metal particles together as a pair. In certain embodiments, the sequence of BD1 can be poly[adenine] for example, A₁₀. The sequence of BD2 can be poly[thymidine], for example, T₁₀. Thus, A₁₀ can hybridize to T₁₀, thereby forming a stable hybrid. In other embodiments, the lengths of the binding domains can be any convenient length that permits the formation of a stable hybrid.

[0153] In other embodiments, illustrated in FIG. 4c, BD1 and BD2 can be selected to be complementary to a third nucleic acid, herein termed a "bridge nucleic acid" or ("BNA"), comprising two sequences, one complementary to BD1 and an other complementary to BD2. When the BNA is placed in contact with BD1, the portion of BNA comple-

mentary to BD1 can form a stable hybrid of the first metal particle M1 with L1 and BNA attached thereto. However, the portion of the BNA that is complementary to BD2 of L2 is free to hybridize to BD2. Upon exposure of the M1-L1-BNA complex to the M2-L2, the BD2 can bind to that portion of the BNA complementary to BD2, forming a stable particle pair.

[0154] FIG. 4d depicts an alternative particle pair in which the inter-linking molecules are attached by way of their ends. This can be accomplished, for example, by treating the particle pair shown in FIG. 4c with a DNA ligase to form a covalent bond between L1 and L2, and then by digesting away the bridge nucleic acid.

[0155] After the pairs of particles are formed, additional linkers can be attached to the particle pairs, and the process can be repeated to form "pairs of particle pairs." Subsequently, the process can be repeated until 3 or more orders of particle structures are formed. Under these conditions, one can manufacture structures having any desired porosity. In general, the size of the nanoscale structures should have average dimensions in the range of about 20 nm to about 500 nm. In alternative embodiments, the dimensions can be in the range of about 50 nm to about 300 nm, and in other embodiments, in the range of about 100 to about 200 nm, and in yet other embodiments, about 150 nm.

[0156] In other embodiments of this invention, the linking can be carried out using an aryl di-thiol or di-isonitrile molecules. FIG. 5 depicts the structure of a class of linkers having thiol (SH) groups at each end. Alternatively one can use any active moiety that can be used to attach the linker to the metal particle. It can be desirable to use the above types of aryl linkers with nucleic acid or other types of linker molecules. The linker can have a central area having ethylbenzene moieties, where n is a number between 1 and about 10,000.

[0157] In general, the ratio of length for each subsequent pairs of linkers can be in the range of about 2 to about 20. Alternatively, the ratios of lengths of subsequent pairs of linkers can be in the range of about 3 to about 10, and in other embodiments, about 5. In certain other embodiments, the ratio of linker lengths in successive orders can be non-constant, thus resulting in the manufacture of an ordered, non-fractal structure.

[0158] For example, for a three-order manufacturing process, it can be desirable for the ration of L1:L2:L3 to be in the range of about 1:2:4. Alternatively, the ratio can be about 1:5:25, and in yet other embodiments, the ratio can be about 1:20:400. In other embodiments, the ratio between L1 and L2 and from L2 to L3 need not be the same. Thus, in certain embodiments the ration of L1:L2:L3 can be 1:3:20, or alternatively, 1:20:40.

[0159] 3. Manufacture of Suspensions of Fractal Particle Associates

[0160] In certain other embodiments of this invention, suspensions of fractal particle associates (fractal associates) can be used, for example, to provide a structure in solution that can bind or retain analytes for detection using methods of this invention. The size of fractal particle associates can be in the range of from hundreds of nanometers to mm dimensions. The fractal associates can comprise a number of particles arranged by means of chemical linkers. The num-

ber of particles per fractal associate can be as few as about 100 particles, or alternatively, thousands can be used to form a fractal associate. By increasing the number of particles in a fractal associate, the increase in the void size increases by a greater proportion.

[0161] 4. Nested Fractal Structures

[0162] In another series of embodiments of this invention, nested fractal structures are provided. Nested fractal structure, for example, comprises a core of a large particle, surrounded by a "halo" of smaller particles, and each of the smaller particles is surrounded by a "halo" of even smaller particles. (See Example 6). Nested fractal structures can be especially useful for generation of essentially uniform fractal surfaces for enhanced analyte detection. It can be desirable to include large excesses of smaller particles compared to larger particles for each successive step. For example, it can be desirable to have excess of smaller particles in the range of about 10 to about 1000 times the number of larger particles. Alternatively, it can be desirable to have an excess of smaller particles of between 10 and 100 times the number of larger particles, and in other embodiments, it can be desirable to have smaller particles in excess of about 10 times the number of larger particles.

[0163] 5. Lithographic Manufacture of Particle Structures

[0164] In other embodiments of this invention, particle structures can be manufactured using lithographic methods known in the semiconductor manufacturing arts. To manufacture particle structures, an image of the particle structure to be made can be made and stored in a computer memory. Each point defining the particle structure can be represented by a single location within the memory. The memory device can then direct the projection of a beam of electromagnetic radiation, electrons, or other particles locally onto a suitable surface. The beam can create site on the surface for the subsequent formation of a metal particle at desired locations.

[0165] By way of example, such a method is disclosed in Xioa et al, *Hunting for the Active Sites of Surface-Enhanced Raman Scattering: A New Strategy Based on Single Silver Particles*, *J. Physical Chemistry B* 101:632-638 (1997), incorporated herein fully by reference. FIG. 6 depicts several steps in the lithographic manufacture of a particle structure of this invention. FIG. 6a shows an image 600 of a desired distribution of nanoparticles. The image is stored in a computer memory, in which each particle is represented by a pair of reference coordinates, one x and one y for each point. FIG. 6b depicts a substrate for nanoparticle structure 610 comprising a gold substrate 615 having a film of hexadecanethiol 620 on which the nanoparticle structure is to be manufactured. FIG. 6c illustrates the placement of the tip 635 of a scanning tunneling microscope (STM) over the gold substrate 615 at a point stored in the computer memory. Electrons emitted from the tip 635 of the STM can interact with the hexadecanethiol film 620 to cause a patch 637 to form, and subsequent etching with cyanide (FIG. 6d) can expose a series of patches 637 in the surface of the underlying gold substrate 615. Thus, the pattern of particle positions stored in the computer's memory can be physically reproduced on the surface of the substrate. Subsequently, silver or other metal can be electrochemically deposited only at those locations 645 where the hexadecanethiol film 620 has been removed, thus forming the nanoparticle structure 650 (FIG. 6e).

[0166] Alternatively, traditional semiconductor masks can be used to direct the location of nanoparticle structures on substrates. Regardless of the method used, the result obtained will provide for resonance properties of the structures.

[0167] II. Manufacture of Receptor-Derivatized Particle Structures

[0168] Once the particle structures of metal particles have been manufactured, receptors can then be attached, thereby forming receptor-derivatized structures that are useful for spectroscopic detection and quantification of analytes.

[0169] A. Selection of Receptor

[0170] The receptor chosen to be attached to particle structures of this invention will depend on binding properties of the desired analyte. For example, to detect and quantify nucleic acid sequences, it can be desirable to use oligonucleotide receptors. Oligonucleotide receptors can hybridize to analyte nucleotide sequences, thereby producing a bound ligand. Alternatively, if desired, one can use an antibody directed against a nucleotide sequence to bind the nucleic acid. In other embodiments, DNA binding proteins can be used. For example, to detect certain promoter regions of genes, specific promoter-binding proteins can be used as receptors. Moreover, or peptide nucleic acids can be used to bind native nucleic acids.

[0171] Similarly, to detect protein analytes, antibodies and other, specific protein binding molecules can be used. Once the type of analyte is chosen, the specific receptor molecule and the conditions for its attachment to the fractal array can be determined. Additionally, antibodies directed against low molecular weight analytes can be attached to a substrate.

[0172] By way of example, the nucleic acid receptors can advantageously be used in a large scale matrix array to measure a large number of analyte sequences simultaneously.

EXAMPLE 4

Synthesis of Receptors of Nucleic Acid Oligomers

[0173] Thiol-derivatized DNA oligomers are synthesized by standard phosphoramidite chemistry according to the methods of Caruthers *Gene Synthesis Machines: DNA Chemistry and Its Uses*, *Science* 230:281-285 (1995), incorporated herein fully by reference. Such oligomers are obtained from Dr. Keith McKenney of The Institute for Genomic Research (TIGR), Rockville, Md., and are prepared according to the methods of Peterlinz et al. *Observation of Hybridization and Dehybridization of Thiol-Tethered DNA Using Two-Color Surface Plasmon Resonance Spectroscopy*, *Journal American Chemical Society* 119:3401-3402 (1997), incorporated herein fully by reference.

[0174] The DNA oligomers are selected to be in the range of about 10-50 bases in length, although much longer sequences can also be used. In other embodiments, the DNA oligomers are in the range of about 15-30 bases in length, and in alternative embodiments, the DNA oligomers are about 25 bases in length. If the oligomer is too long, the analyte molecule can be too far from the metal surface, and the surface enhancement of Raman resonance can be undesirably low. If the oligomer is too short, the specificity of hybridization can be too low. Therefore, the length of the oligomer is selected to optimize the sequence specificity and resonance enhancement of the analyte. In situations in which sequence specificity is less important than resonance

enhancement, shorter oligomers can be desirable. Conversely, in situations in which a high degree of sequence specificity is desired, longer oligomers can be desirably used.

[0175] Two sets of complementary nucleotide oligomers are synthesized, one set being manufactured using moieties that lack a Raman active component. In certain embodiments, the DNA oligomer is synthesized using 2,6-diaminopurine instead of adenine.

[0176] In other embodiments of this invention, peptide nucleic acid ("PNA") receptors are used. Peptide nucleic acids have an affinity to RNA and DNA comparable to that of DNA, (Griffin (1998); Kyger et al (1998); Igloi (1998); Ratilainen et al. (1998), each reference herein incorporated fully by reference), and thus, can form hybridization pairs with mRNA. The difference between the chemical structures of PNA and DNA can result in a pronounced difference in their Raman spectra. In particular, the bands corresponding to nucleic acid phosphodiester backbone bonds, absent in the PNA attached to a substrate, appear when the PNA is bound to a DNA or mRNA ligand upon hybridization (Guan (1996)). PNA fragments can be obtained from Atom Sciences (Oak Ridge, Tenn.).

[0177] B. Attachment of Receptors to Metal Colloid

[0178] In general, oligomers can be attached to metal surfaces via an alkanethiol covalently linked at the 5' position of single-stranded DNA oligomers according to the methods of Herne, *Characterization of DNA Probes Immobilized on Gold Surfaces*, *Journal American Chemical Society* 119:8916-8920 (1997), incorporated herein fully by reference. The attachment can be irreversible, thereby permitting hybridization and dehybridization on the surface (Peterlinz et al., *Observation of Hybridization and Dehybridization of Thiol-Derivatized DNA Using Two Color Surface Plasmon Resonance Spectroscopy*, *Journal American Chemical Society* 119:3401-3402 (1997), incorporated herein fully by reference). However, any method can be used that results in the attachment of receptor molecules to metal surfaces and can permit the receptor to maintain the physical characteristics necessary for specific binding to ligands.

EXAMPLE 5

Linking of DNA to Colloidal Gold

[0179] The colloidal gold-coated quartz slides of Example 3 can then be used as a matrix or substrate for the binding of DNA used for hybridization detection of analyte nucleic acids.

[0180] The gold colloid derivatized slides are placed in 1.0 M KH_2PO_4 buffer solution, pH 3.8, containing 1.0 μM thiol-derivatized DNA for a specific amount of time to achieve thiol-tethering of DNA. The surface is then passivated by exposing the DNA tethered slides to 1.0 mM mercaptohexanol ($\text{HS}(\text{CH}_2)_6\text{OH}$) for 1 hour. This treatment eliminates nonspecific binding of polynucleotides. Thorough rinsing with deionized water is required before analysis of hybridization.

[0181] C. Attachment of Receptors to Resonance Domains

[0182] In other embodiments of this invention, receptors can be localized to resonance domains within particle structures. Upon illumination of the particle structures, resonant domains can be heated, and that heating can cause partial

melting of the metal particles. Typically, the dimensions of resonance domains are smaller than the wavelength of the incident light. The size of the resonance domains generated at certain wavelengths of incident light can be on the order of $\frac{1}{2}$ s of the wavelength of the light used in their generation. However, as the wavelength of light becomes longer, the size of the resonance domains can become smaller. Resonant domains are areas that can exhibit intense resonance, and can produce greater amplification of Raman signals than that possible in unaggregated metal or metal colloid substrates. Thus, resonance domains that are especially useful for this invention can be made using incident light, which can result in resonance domains comprising between about 4 to about 10 monomer particles.

[0183] In certain embodiments of this invention, the property of particle structures to become locally heated can be used advantageously to localize receptor molecules to those locations. To manufacture a particle structures having localization of resonance domain-specific receptors, a surface containing particle structures is prepared as above. A solution containing receptor molecules is then placed on the surface and in contact with the particle structures. Pulses of laser light are used to illuminate the surface, and at those locations where resonance domains are created, the local temperature of the reaction mixture can reach the threshold for the formation of intermolecular bonds between the particle structures and the receptor, thus attaching the receptor to the particle structures. In general, any thermosensitive chemistry for linking the receptors to the substrate can be used.

[0184] Generally, the power required to initiate receptor molecule derivatization is less than that needed for photoaggregation. It can be desirable to provide temperatures at the resonance domains in the range of about 0° C. to about 500° C., alternatively in a range of about 20° C. to about 300° C., in other embodiments, in the range of about 50° C. to about 180° C. In yet other embodiments, the temperature can be in the range of about 70° C. to about 100° C.

[0185] The temperature needed will vary with the threshold temperature required to initiate the linkage of the receptor to the metal surface. In certain embodiments, it is desirable that the temperature locally at the resonance domains remain below the temperature at which bond breakage and reversal of the bond between the receptor and the metal surface occurs.

[0186] In other embodiments of this invention, photosensitive reagents can be used to link the receptor to the particle structures at specific locations. A number of such reagents can be obtained from Pierce Products Inc., Rockford, Ill. By the use of different photochemical linking agents, one can link different types of receptors to the same substrate. For example, one can attach DNA and proteins to the same substrate.

[0187] It can be desirable to limit the attachment of receptor molecules to specific sites on a substrate. This can be accomplished by using wavelengths of light that are relatively short, for example, less than about 1000 nm, in other embodiments, below about 600 nm, in yet other embodiments, below about 400 nm. Also, laser light can be desirable in situations in which the site of attachment is to be localized to areas of high electric field. In this case, it can be desirable to use double- or triple-photon processes, in

which multiple photons having long wavelengths can reach the photoreactive moiety on the receptor and particle structure to provide sufficient energy to cause a linking reaction to occur. This can occur even if the energy of a single photon is insufficient to initiate the photochemical reaction.

[0188] Once manufactured, receptor molecules localized to the resonance domains of the fractal arrays can remain at those locations during subsequent exposures to incident light.

[0189] In other embodiments of this invention, attachment of receptors at resonance domains can be performed using a scanning atomic force microscope (see Hansen et al. "A Technique for Positioning Nanoparticles Using an Atomic Force Microscope", *Nanotechnology* 9:337-342 (1998), incorporated herein fully by reference). having a capillary tip and optical feedback. In these embodiments, the capillary contains derivatized receptors which can be deposited onto a surface. In the process of deposition, the surface can be illuminated by incident electromagnetic radiation produced by a laser. At resonance domains, the resonance increases the intensity of the emitted radiation and thereby provides a signal to the optical feedback device to initiate deposition of receptors at those locations, depending upon the intensity of electromagnetic radiation emitted from the surface in response to external illumination provided by the laser.

[0190] **FIGS. 7a** and **7b** depict embodiments of this invention in which receptor molecules are attached to resonance domains of particle structures. **FIG. 7a** depicts an area of a particle structures in which the receptor molecules are native, adenine ("A")-containing oligonucleotides. **FIG. 7b** depicts a particle structures similar to that shown in **FIG. 7a** but having the adenine moieties replaced by 2, 6-diaminopurine ("AP").

[0191] **FIG. 8a** depicts the binding of native, complementary oligonucleotide analytes to a particle structures containing receptors as shown in **FIG. 7b**, having adenine replaced by 2, 6-diaminopurine (AP). Analyte molecules containing adenine (A) are depicted as hybridizing to the oligonucleotide receptor such that the adenine residues bind to the 2, 6-diaminopurine residues of the receptor molecule.

[0192] III. Design and Manufacture of Matrix Arrays

[0193] The processes described above for the derivatization of metal colloid aggregates can be extended to the manufacture of matrix arrays having a large number of different receptors. In such an array, there can be numerous individual defined areas, or "cells" that have a particular type of receptor bound to the metal colloid aggregate. The size of each cell can be on the order of about 100 μm ×100 μm . Within each of these cells, a single type of receptor-fractal aggregate can be manufactured. Thus, in a matrix array of 10 cm×10 cm, there can be up to about 10⁶ different cells, each of which can have a different fractal aggregate receptor type.

[0194] **FIG. 8b** depicts an array comprising numerous cells or defined areas, each of which has particle structures containing a plurality of receptors bound to each defined area, and being specific for a desired analyte. The large-scale array shown is a 10×10 matrix, with individual cells positionally located within the large-scale array. Other array configurations can be desirable, and includes arrays having identifier moieties different from the receptor molecules.

Identifier moieties can be used to define the position and/or the type of receptor molecule characteristic of the particular defined areas. Such identifier moieties can include nucleic acids of defined sequence, or can include identifiers produced by combinatorial chemical methods known in the art. Moreover, defined areas can be identified using colored markers.

[0195] By way of example only, a large-scale array containing fractal aggregates can be exposed to a first receptor type and a beam of highly focused incident light can selectively illuminate one or a few specific cells, thereby linking the first receptor to the substrate in only those cells in which fractal aggregates with the first receptor type is desired. Beams of highly focused laser light having the necessary dimensions can be routinely produced using of photolithography methods used in semiconductor manufacture. Subsequently, the substrate can be washed to remove unbound first receptor type, and a second receptor type can be applied to the substrate. Laser light can illuminate different cells to link the second receptor type to fractal aggregates to form fractal aggregates with the second receptor type. The process of sequential application of any desired number of different receptor types to different cells in the matrix array can be carried out using the same chemistry of linkage if desired, or different types of chemical linkage can be used. The methods above can be fully automated, so that the reproducibility of manufacture of fractal aggregates can be quite high.

[0196] A result of this process is that a matrix array containing a large number of positionally identifiable cells can be manufactured. Such arrays can be used to detect and determine sequences of DNA or mRNA, using strategies as described in, for example, U.S. Pat. No. 5,925,525, incorporated herein fully by reference.

[0197] IV. Detection of Analytes

[0198] Detection of analytes according to methods of this invention includes the use of a Raman reader and a matrix array. Detection can be performed using a pre-manufactured substrate having particle structures atop the substrate. The substrate can have cells or defined areas thereon, having a single type of receptor. When a sample containing an analyte is applied to such a matrix, analytes can bind to or be retained by receptors having sufficient affinity. The matrix can then be washed to remove unbound analytes, leaving only those analytes that have a sufficient affinity for the receptors to which they are bound. The matrix array can then be subjected to analysis using a reader or be performed using a light source focused upon the array, one cell at a time. Light is projected at the cell, and reflected, scattered, or re-emitted light can be collected and transmitted to the light detector. Collected light can be analyzed for Raman spectral features, and such features can be compared with Raman features derived from known moieties. Such known spectra can be imported from external databases, which can include information on biological significance of specific analytes. Analysis of information can be performed using a computer, which can be associated with a memory device for storing a program to carry out spectral analyses. Also, an output device, such as a screen display or a printer can provide information to the user. Such comparison can be the basis for determining the amount of analyte in the cell on the matrix array. Additionally, changes in the analyte due to the con-

ditions of measurement can be determined, and any artifacts, such as non-specific binding so introduced can be discovered.

[0199] In other embodiments, detection can be performed under conditions in which resonance of electron transition in analyte molecules does not occur. According to one theory, this situation can be created when the frequency of incident light does not overlap the absorbance band of the analyte. In these situations, it can be desirable to add a suspension of particles atop the substrate and receptor analyte complexes. Enhancement of Raman signals can be sufficient to provide a highly sensitive detection.

[0200] In certain other embodiments, a combination of resonance conditions and enhancement provided by particle structures can be desirable to provide high sensitivity. In yet other embodiments, a Raman array reader can be used to detect and quantify the amount of analyte bound to a cell of a matrix array. A Raman reader can be used for parallel, rapid and sensitive detection of analytes by acquiring Raman spectral features of each cell of an array and comparing the spectral features with known spectral features. Thus, the existence, identity and amount of an analyte can be determined.

[0201] In some embodiments, it can be desirable to use light sources that provide different wavelengths of light simultaneously. These sources can be less expensive and if the wavelengths are sufficiently different from each other, the interference with acquiring unique Raman spectra can be minimized.

[0202] Detection of analytes according to some embodiments of this invention is advantageously carried out using native analytes. To carry out such a detection, it can be desirable to use receptor molecules that are lacking a structural feature of the analyte that is responsible for a Raman signal. Such a strategy is termed herein, "Reverse Raman Spectroscopy," or "RRS." In general, nucleic acids can be detected advantageously using RRS. Several examples of this strategy follow herein below

[0203] A. Modified Nucleic Acid Receptors

[0204] Detection of nucleic acid analytes using RRS typically involve the use of receptor molecules that are lacking native nucleotide bases. The nucleotide bases cytosine, uracil, thymine, guanine and adenine each exhibit Raman bands at wave numbers in the range of about 610 cm^{-1} to about 800 cm^{-1} . Several nucleotide analogs that have no Raman bands in this range can be suitable for use with the methods and compositions of this invention.

[0205] 1. Substitution of Adenine

[0206] The nucleotide adenine is composed of a purine ring structure that has a characteristic Raman scattering band at 733 cm^{-1} (Kurokawa et al. *Surface-Enhanced Raman Spectroscopic Detection of CO₂, SO₃, and Nucleic Acid Bases Using Polyvinyl Alcohol Film Doped with Ag Fine Particles. Analytic Biochemistry* 209:247-250 (1993), incorporated herein fully by reference. If a receptor molecule incorporates adenine as a base to pair with thymine residues according to Watson-Crick base pairing, there will be a large Raman band observed at 733 cm^{-1} even though no analyte is adsorbed to the receptor, thus, making the resolution of analyte nucleic acids containing adenine difficult. Because

most nucleic acids of interest contain adenine, the presence of native adenine in receptors poses a problem.

[0207] To overcome this problem, an adenine analog can be incorporated into the receptor nucleic acid sequence in the place of adenine. Any adenine analog that (1) lacks a characteristic Raman band, and (2) can bind to a complementary base according to Watson-Crick base pairing can be used. By way of example only, by incorporating the adenine analog, 2, 6-di-aminopurine (“2,6 AP”) instead of adenine in a nucleic acid sequence, and then incorporating that sequence into a fractal array receptor aggregate, the background Raman spectrum does not have the characteristic band at 733 cm^{-1} . However, 2, 6 AP does not interfere substantially with its pairing with thymine (Hacia et al., *Enhanced High Density Oligonucleotide Array-Based Sequence Analysis Using Modified Nucleoside Triphosphates Nucleic Acids Research* 26:4975-4982 (1998), incorporated herein fully by reference). Subsequent binding of native nucleic acids that contain adenine cause the appearance of the Raman band at 733 cm^{-1} , and thus, the hybridization signal is specific for the native nucleotide sequence that binds to the receptor.

[0208] FIGS. 9a-9b are graphs illustrating the principle of use of an oligonucleotide receptor not having adenine in Raman spectroscopic detection of oligonucleic acids that contain adenine. FIG. 9a depicts a portion of a Raman spectrum of a nucleic acid not having adenine residues or other moieties having a Raman band at 733 cm^{-1} . FIG. 9b depicts the Raman spectrum obtained upon binding of an oligonucleotide containing adenine to a receptor molecule not having adenine as in FIG. 9a, showing the presence of a Raman band at 733 cm^{-1} .

[0209] 2. Substitution of Thymine

[0210] In a fashion similar to that described above for adenine, RRS can be carried out using receptors in which thymine is replaced with any analog which lacks a characteristic Raman band and can form complementary base pairing with a nucleic acid according to Watson-Crick base pairing. By way of example only, thymidine can be replaced by 5-methyluridine in DNA oligomers attached to the matrix, without losing the capacity to hybridize with complementary bases (Hacia et al., *Nucleic Acids Research* 26:4975-4982 (1998), incorporated herein fully by reference). Thymine can also be replaced with 5-(1-propynyl)uridine.

[0211] 3. Substitution of Guanine

[0212] Guanine has a hydrogen atom at position 8 that can be essentially completely replaced (by about 97%) with deuterium. This deuterium substitution can be carried out by incubation of the nucleic acid in D_2O at 90°C . according to the methods of Manor et al. *An Isotope Edited Classical Raman Difference Spectroscopic Study of the Interactions of Guanine Nucleotides with Elongation Factor Tu and H-Ras p21*, *Biochemistry* 30:10914-10920 (1991), incorporated herein fully by reference. Deuteration of guanine shifts the Raman band from about 1486 cm^{-1} to about 1463 cm^{-1} (Manor et al., *Biochemistry* 30:10914-10920 (1991), incorporated herein fully by reference).

[0213] The substitution of hydrogen by deuterium permits the manufacture of a RRS receptor oligonucleotide that is lacking in native guanine. Therefore, upon hybridization to

the deuterated guanine receptor, the native guanine provides the characteristic Raman band indicating the presence of the analyte bound to the receptor oligonucleotide.

[0214] FIG. 9c depicts a graph of wave number in cm^{-1} and the intensity of Raman scattering observed (in arbitrary units) of a sample containing 500 mg/mL guanine in 10 M KOH. Excitation is at 514 nm with a laser power of 1 Watt and the spectrum was acquired within 3 seconds using a charge coupled device (CCD). Peaks in intensity can be observed at about 980 cm^{-1} , about 1220 cm^{-1} , about 1240 cm^{-1} , about 1280 cm^{-1} , 1345 cm^{-1} , about 1390 cm^{-1} , about 1470 cm^{-1} and about 1555 cm^{-1} . This pattern of peaks is similar to the pattern previously published. Without enhancement, this system can detect guanine in a concentration of about 20 mg/mL.

[0215] 4. Peptide Nucleic Acids

[0216] As described above for substitution of adenine, thymine and guanine in oligonucleic acid receptors, replacement of those bases in peptide nucleic acids can also result in the manufacture of receptors that lack a characteristic Raman band of a native nucleic acid. Upon binding the native analyte, the characteristic Raman band can be detected and quantified.

[0217] B. Modified Protein Receptors

[0218] In fashions analogous to those described above for modified nucleic acid receptors, according to the methods of this invention, one can synthesize protein receptors that lack a characteristic signal found in native proteins. By way of example only, the amino acid, tryptophan (“Trp”), in an antibody can be replaced by $z^7\text{Trp}$ during the synthesis of the antibody. $Z^7\text{Trp}$ is disclosed in Cornish et al., *Site-specific Incorporation of Biophysical Probes Into Proteins*, *Proceedings of the National Academy of Science (USA)*: 91:2910-2914 (1994), herein incorporated fully by reference. Alternatively, antibodies directed toward insulin or other cysteine-containing proteins and peptides can be prepared without cysteines, the cysteines being replaced with selenocysteine or homocysteine. The Raman spectral features associated with cysteine or cystine can be clearly detected in the presence of such antibody receptors. Moreover, other artificial amino acids can be used to replace native amino acids in proteins. Any artificial amino acid that lacks a characteristic Raman signal and does not substantially disrupt secondary, tertiary or quaternary structures be advantageously used in RRS. Thus, using RRS, a native protein binding to a substituted receptor can be used to detect the protein analyte. Similarly, deuterium (D) can replace hydrogen in certain proteins.

[0219] C. Detection Using Unmodified Receptors

[0220] In certain other embodiments of this invention, it is not necessary to substitute an analog that lacks a characteristic Raman band into a receptor molecule. Hybridization of complementary oligomeric nucleic acids can shift the Raman spectrum. However, the magnitude of the shifts caused by hybridization are relatively small, so it can be desirable to enhance specific Raman features to increase the signal.

[0221] D. Specificity of Ligand-Receptor Binding

[0222] The level of specificity of an assay of this invention can depend on the purposes of the assay. For example, if the

aim of the assay is the detection of any of a series of related nucleotide sequences, herein termed "homologues," the fidelity of the hybridization reaction need not be as high as an assay in which the detection and identification of single nucleotide polymorphisms ("SNPs"). The methods and compositions of this invention are well suited to detecting the presence or absence of a Raman band within a particular cell of a matrix array. Moreover, because the intensity of a characteristic Raman band is increased as the number of bound analyte moieties increases, the methods of this invention can be used to quantify the amounts of analytes in an assay.

[0223] In general, the specificity of nucleotide-nucleotide hybridization reactions can depend on the conditions of hybridizations, herein termed "stringency." Hybridization conditions are described in Sambrook et al., *Molecular Cloning: A Laboratory Manual, Second Edition*, Cold Springs Harbor Laboratory Press (1989), incorporated herein fully by reference. In general, as used herein, the term "high stringency" refers to conditions in which the temperature of hybridization is about 5° C. to about 10° C. below the melting temperature of the duplex. The melting temperature_{TM} of an oligonucleotide duplex can be estimated as follows:

$$T_m = 81.5 - 16.6(\log_{10}[\text{Na}^+]) + 0.41 \left(\frac{\text{fraction C+G}}{600/\text{N}} \right)$$

[0224] where [Na⁺] is the sodium concentration, C+G is the amount of cytosine (C) and guanine (G) as a fraction of the total number of nucleotide bases, and N is the chain length. High stringency involves either the incubation of or the washing of ligand and receptor nucleotides under conditions that disfavor hybridization of non-complementary sequences. Such conditions include the use of high temperatures, low salt concentration and high detergent concentrations. Using high stringency, detection of sequences having only one non-complementary base (one "mismatch") can be accomplished. Conversely, low stringency conditions include lower temperatures, higher salt concentrations and lower concentrations of detergents. Low stringency conditions can be especially desirable if the purpose of the assay is the detection of homologues, in which base-pair mismatches are present.

[0225] Moreover, in certain embodiments of this invention, one can obtain qualitative information regarding the number of base-pair mismatches by making repeated Raman spectroscopic measurements of the same cell under progressively higher stringency conditions. For example, if an analyte has a relatively large number of mismatches, so that a detectable Raman signal is present only after low stringency washing, subsequent washing of the same cell at high stringency conditions can remove the analyte from that cell. This stringency is herein termed the "stringency threshold." By comparing the number of mismatches with the stringency threshold, one can determine the relative degrees of homology of nucleic acid sequences without determining the actual sequences.

[0226] The specificity of binding of analytes is of ten not perfect, especially when antibodies are used. Antibodies can bind other analytes non-specifically, in addition to their direct targets. In such situations, spectral analysis of Raman spectral features can permit discrimination and quantification of the desired analyte even in the presence of non-specific binding.

[0227] E. Detection of Analytes By Raman Spectroscopy

[0228] 1. Raman Spectroscopy of Analytes

[0229] Devices used to perform analyses according to the methods of this invention can include any device that can produce laser light of the wavelengths needed for analysis. For example, the T64000 Raman Spectrometer (The Ultimate Raman Spectrometer Instruments S.A. Ltd. (UK) can be used. Alternatively, one can use a Raman System 2000 produced by Chromex, Inc. Albuquerque, N.M., or other suitable Raman devices. Desirable features of a suitable instrument include the ability to position the sample compartment to adjust the sensitivity of the spectrum, provides for low frequency measurements, provides adequate spectral resolution, and a liquid nitrogen cooled charged coupled device ("CCD") detector. The spectrometer is suitably equipped with a laser light source comprising a continuous wave, frequency doubled argon laser. Because the purine and pyrimidine ring structures of nucleotides have characteristic absorption maxima in the ultraviolet range, it can be desirable to provide laser light having emission wavelengths in the ultraviolet range. A suitable laser is the Inova 300 FRd, available from Coherent Inc., Santa Clara, Calif. Laserpower for certain embodiments of this invention can be maintained at about 5 milliwatts at 257 nm, or 1 milliwatt at 244 nm, 229 nm and 238 nm.

[0230] For other applications, it can be desirable to use wavelengths in the range of about 200 nm to about 2000 nm. In certain of these embodiments, it can be desirable to use wavelengths in the range of about 1000 to 1100 nm, alternatively at 1064 nm (Nd-YAG laser). Long wavelengths, for example from about 780 nm to about 2000 can be desirable to avoid fluorescence. Wavelengths below about 250 nm can also be desirable to avoid fluorescence. Such lasers having wavelengths below about 250 are commercially available.

[0231] For other applications, it can be desirable to use longer wavelengths, for example, in the range of about 830 nm. Such a light source is a continuous-wave titanium:sapphire laser. One commercially available Raman spectrometer system (Raman System 2000) operates at about 785 nm. For other applications, wavelengths in the visible range can be suitable.

[0232] To detect analytes in a single cell, it can be desirable to provide Raman spectroscopic measurements over areas that are sufficiently small to avoid cross-readings from adjacent cells. For matrix arrays having 100 μm×100 μm per side, it is desirable to provide a narrow, focused beam of incident light.

[0233] IV. Analysis of Data

[0234] To determine whether a cell has bound analyte, all that is needed is to compare the intensity of the characteristic Raman bands of a cell before exposure to the mixture of analytes to the intensity of the same Raman bands in the same cell after exposure to the analyte. Alternatively, for matrix arrays in which the receptors all have a characteristic Substituent, (e.g., 2,6 AP), one can use any cell prior to analyte exposure as a reference cell.

[0235] The reference cell can typically exhibit a Raman spectrum having several bands corresponding to invariant molecules. Such can be an internal standard for the comparison of cells having bound analyte. Moreover, if desired, one can incorporate into each cell, a known reference Raman label that is not present in the analyte sample. Thus, upon exposure of the cell to light under conditions of analysis, any change in light transmission or absorption that is due to non-specific Raman scattering can be evaluated in situ.

[0236] For determination of whether analyte-receptor binding occurs, a threshold increase in the intensity of a Raman spectral feature can be selected. For measurements not requiring quantification of analyte-receptor binding, this threshold can be set to a convenient, high level. For example, about 25% of the maximal signal. For alternative embodiments, in which the intensity of Raman signal is to be carefully assessed, it can be desirable to set the threshold to a lower value, for example, 2-5% of the maximal Raman signal.

[0237] Once the presence and/or amount of analyte is determined, subsequent operations can be carried out to provide additional information. For example, if the analysis is to determine the presence of an oligonucleotide having a desired sequence, the intensity of Raman signal from related cells can be compared. If a series of cells contains receptors having overlapping oligonucleotide sequences, as described, for example, in U.S. Pat. No. 5,925,525, incorporated herein fully by reference, then the presence of analyte in the related cells can provide information concerning the sequence and overall size of the particular analyte in question.

EXAMPLE 6

Manufacture of Nested Particle Associates

[0238] By way of example only, a nested particle associates can be made by selecting colloidal solutions of metal gold particles of uniform size, being 10 nm, 40 nm and 240 nm in diameter, respectively. FIGS. 10a-10c depict the manufacture of a nested particle structure made from such particles.

[0239] FIG. 10a depicts a 10 nm gold particle 1004 having a DNA linker 1012 attached thereto. 40 nm particle 1008 having DNA linker 1016 being complementary to DNA linker 1012 is attached to particle 1008. Mixtures of particles 1004 and 1008 are placed in solution and interact with each other DNA linkers to form a first-order nested structure 1020 as shown in FIG. 10b.

[0240] FIG. 10c depicts a second-order nested particle structure having particles 1004 and 1008 as shown in FIGS. 10a and 10b, but with the addition of a larger particle 1024 having a diameter of 240 nm, surrounded by first order nested particles 1020 to form second order nested particle 1028. Heating the mixture of first-order or second-order to a temperature less than about 100° C. and then cooling the mixture can result in better ordering of the nested particles.

EXAMPLE 7

Manufacture of Surfaces Having Non-Random Particle Structures

[0241] FIGS. 11a-11g depict alternative embodiments of surfaces having fractal particle structures thereon. FIG. 11a

depicts a substrate 1104 having a top surface 1108. FIG. 11b depicts the surface 1108 as shown in FIG. 11a after being activated, resulting in thiol groups 1112 attached to surface 1108.

[0242] FIG. 11c depicts a plurality of particles 1004 being smaller than intermediate particles 1008. FIG. 11d depicts second-order nested particle structures 1028 made from first-order nested particles structures 1020 made from the small particles 1004, the intermediate particles 1008 and larger particles 1024.

[0243] FIG. 11e depicts chemically linked particle structures 1132 made from small particles 1004 and intermediate particles 1008.

[0244] FIG. 11f depicts an electromagnetic signal enhancer 1132 having substrate 1104 with nested particle structures 1028 thereon.

[0245] FIG. 11g depicts an alternative electromagnetic signal enhancer 1040 comprising substrate 1104 with linked particle structures 1132 as shown in FIG. 11e thereon.

EXAMPLE 8

Manufacture of Biochips with Analyte Receptors and Fractal Particle Structures

[0246] FIGS. 12a-12d depict the manufacture of a biochip having analyte receptors and enhancers. FIG. 12a depicts two rod-shaped particles 1204. FIG. 12b depicts the rod-shaped particles shown in FIG. 12a and analyte receptors 1208 with connectors 1212. Some of the analyte receptors 1208 are shown attached to rod 1024 by connectors 1212 forming receptor-rod complex 1216.

[0247] FIG. 12c depicts a biochip 1226 comprised of substrate 1220 with linkers 1224 and having receptor-rod complexes 1216 attached thereto.

[0248] FIG. 12d depicts an alternative biochip 1228, similar to biochip 1216 depicted in FIG. 12c, but further comprising linked particle structures 1132 as depicted in FIG. 11e.

EXAMPLE 9

Biochip Made With Non-Nested Particles

[0249] FIGS. 13a and 13b depict two views of additional embodiments 1324 of this invention having receptor-rod complexes and non-nested particles.

[0250] FIG. 13a depicts a top view of a biochip having two types of structures. On the right side of FIG. 13a, structure 1324 has linearly arranged rods 1204 having receptors 1212 attached thereto as depicted in FIG. 12b. The rods 1204 are depicted as being present within trenches 1308. Some rods 1204 are shown parallel to each other, and others are shown end-to-end, although other configurations are within the scope of this invention. The right side of FIG. 13b depicts a cross-sectional view along line A-A' through the embodiment 1324 depicted on the right side of FIG. 13a. Trenches 1308 have receptor-rod complexes 1216 therein. The trenches 1308 can be either parallel as shown, or can be non-parallel.

[0251] The left side of FIG. 13a depicts an alternative biochip, comprising the biochip as depicted in embodiment

1324 but additionally having particles **1320** distributed over the substrate **1304** and the receptor-rod complexes. Particles **1320** can be made, for example, by laser ablation.

[0252] The left side of **FIG. 13b** depicts a cross-sectional view along line A-A' of the embodiment **1328** as shown in **FIG. 13a**. Substrate **1304** has trenches **1308** with receptor-rod complexes **1216** therein, and having particles **1320** over the top of the substrate **1304** and receptor-rod complexes **1216**.

EXAMPLE 10

Preparation of Fractal Silver Aggregates using Citrate

[0253] Upon dissolving 45 mg AgNO_3 (Sigma) in 250 mL triple distilled, deionized water, the solution was brought to boiling under stirring with magnetic stirrer. A solution of 1% sodium citrate (5 mL) was added drop-by-drop to the boiling solution under vigorous stirring. The solution was kept boiling for 60 min, while a tap water cooled condenser prevented loss of water due to evaporation. The resulting solution of colloidal silver was kept in a dark glass bottle at $5^\circ\text{-}8^\circ\text{C}$. for a period of up to at least several months.

[0254] Fractal aggregates of silver particles were produced by mixing 250 microliters of the colloidal silver solution with 1750 microliters of a water solution of NaCl (Sigma, ultra pure) to bring the final concentration of NaCl to 60 mM. The aggregates formed within several minutes and the solution was fairly stable for at least about half an hour. Fractal aggregates were applied to a metal coated substrate, and the fractal aggregates sedimented and adhered to the metal surface, forming a fractal associate-derivatized metal surface.

EXAMPLE 11

Preparation of Fractal Silver Aggregates using NaBH_4

[0255] A solution of 5 mM AgNO_3 (Sigma) in triple distilled, deionized water (50 mL) was added drop-by-drop to 150 mL ice-cold, 2 mM solution NaBH_4 (Sigma), under vigorous stirring with magnetic stirrer. Right after that, a solution of 1% poly(vinyl alcohol) (25 mL) was added. The mixture was then is boiled for 60 min, while a tap water-cooled condenser prevented loss of water due to evaporation. The solution of colloidal silver was kept in a dark glass bottle at $5^\circ\text{-}8^\circ\text{C}$. for a period of up to at least several weeks.

[0256] Fractal aggregates of silver particles were produced by mixing 250 microliters of the colloidal silver solution with 1750 microliters of a water solution of NaCl (Sigma, ultra pure) to bring the final concentration of NaCl to about 100 mM. The aggregates formed within several minutes and the solution was fairly stable for at least up to about half an hour. Fractal aggregates were applied to a metal coated substrate, and the fractal aggregates sedimented and adhered to the metal surface, forming a fractal associate-derivatized metal surface.

EXAMPLE 12

Preparation of Fractal Gold Aggregates Using Citrate

[0257] Upon dissolving 120 mg HAuCl_4 (Sigma) in 250 mL triple distilled, deionized water, the solution was brought

to boiling under stirring with magnetic stirrer. A solution of 1% sodium citrate (5 mL) was added drop-by-drop to the boiling solution under vigorous stirring. The solution was kept boiling for 60 min, while a tap water-cooled condenser prevented loss of water due to evaporation. The solution of colloidal gold was kept in a dark glass bottle at a temperature of about $5^\circ\text{-}8^\circ\text{C}$. for up to at least about several weeks.

[0258] Fractal aggregates of gold particles were produced by mixing 250 microliters of the colloidal gold solution with 1750 microliters of a water solution of NaCl (Sigma, ultra pure) to bring the final concentration of NaCl to ca. 100 mM. The aggregates formed within several minutes and the solution is stable for at least about half an hour. Fractal aggregates were applied to a metal coated substrate, and the fractal aggregates sedimented and adhered to the metal surface, forming a fractal associate-derivatized metal surface.

[0259] In other embodiments, substrates can be prepared having a metal surface, such as gold, and also having fractal aggregates made of silver colloid as described above in Examples 10 and 11 or alternatively having gold fractal aggregates as in Example 12.

[0260] **FIGS. 14a-14d** depict embodiments of this invention. **FIG. 14a** depicts a prior art slide **1400** in which a substrate **1404** has a layer of gold metal **1408** thereon. **FIG. 14b** depicts an embodiment **1401** of this invention in which the substrate **1404** has a layer of gold **1408** thereon and has silver or gold fractal aggregates **1412** thereon. **FIG. 14c** depicts an embodiment **1402** of this invention, in which fractal aggregates **1412** have receptors **1416** thereon. **FIG. 14d** depicts an embodiment of this invention **1403**, similar to those embodiments shown in **FIGS. 14b** and **14c**, and having analytes **1420** in proximity to receptors **1416**.

EXAMPLE 13

Enhancement of Raman Spectra of DTP on Fractal-Derivatized Substrates

[0261] In this series of experiments, we determined that fractal-derivatized substrates can be used to enhance Raman signals from analytes. We selected a silver fractal-derivatized gold substrate as described above for Example 10. To this substrate, we added a solution comprising 2,2'-dithio-dipyridine (DTP; Sigma Chemical). 20 mg of DTP was added to 1 mL of water (triple distilled deionized) and shaken for 1 minute in a shaker. We permitted the undissolved DTP to settle out of solution and applied 10 microliters (μL) of this solution to 1 mL of water. Raman spectrum of this diluted solution showed no detectible signal characteristic of DTP.

[0262] Then, we added 25 microliters of this solution to a fractal-derivatized substrate and permitted the DTP to adhere to the substrate. We then measured the Raman signal and found a pattern of Raman bands characteristic of DTP.

[0263] **FIG. 15a** depicts the Raman spectrum of DTP on a gold-coated substrate having silver fractal structures thereon. Several distinct peaks characteristic of DTP were observed. **FIG. 15b** depicts the Raman spectrum of DTP on a gold-coated substrate having gold fractal structures thereon. Again, we found a series of distinct peaks characteristic of DTP as seen in **FIG. 15a**. We conclude from these

experiments that devices of this invention incorporating silver and gold fractal aggregates can be used to enhance Raman signals generated by DTP.

[0264] Thus these studies demonstrate (1) that silver and gold fractal-derivatized substrates each can effectively enhance Raman signals, and (2) that such surfaces can be effectively cleaned. Moreover, using these methods, one can control the effectiveness of formation of fractal structures, the attachment of those structures to a substrate, the attachment of a Raman signal generator to fractal structures and the removal of Raman signal generators from substrates. These tools can be widely applied to a wide variety of fractal aggregates, substrates, receptors and analytes. Moreover, DTP can be used as an effective probe of the quality of the fractal aggregates used to enhance spectrographic analysis of analytes.

EXAMPLE 14

Fractal-Derivatized Substrate Having Reduced Glutathione Receptors for Glutathione S-Transferase

[0265] In this series of experiments we wanted to prepare a fractal-derivatized substrate having a receptor attached thereon to be used to bind and detect an analyte using Raman spectroscopy. We used reduced glutathione as a receptor and glutathione S-transferase ("GST") as an analyte. Glutathione is a tripeptide consisting of the three amino acids in order: Glycine-Cysteine-Glutamic acid (Gly-Cys-Glu). It is known in the art that glutathione S-transferase binds to reduced glutathione. Thus, reduced glutathione can be a receptor for binding and analysis of glutathione S-transferase.

[0266] To manufacture a fractal-derivatized substrate, we obtained a quartz substrate having a preformed layer of gold metal thereon. Such slides are commercially available from EMF Corporation, Ithaca, N.Y. The slides were washed for one (1) hour in concentrated nitric acid (HNO_3) to clean the slides, then extensively rinsed with a large excess of distilled deionized water and air dried. FIG. 16a depicts a Raman spectrum of a commercially available gold-coated quartz slide that had been washed with HNO_3 and water as described above. FIG. 16a shows only very weak Raman signals, with no discernable pattern within the noise. Such spectra are characteristic of clean, gold-covered quartz slides.

[0267] Then, we prepared silver fractal aggregates as described above in Example 10. To test the ability of the fractal aggregates to enhance Raman signals, we exposed a small sample of fractal aggregates to DTP.

[0268] FIG. 16b depicts Raman spectrum of such a preparation of saturated DTP diluted 100 fold in the presence of silver fractal aggregates prepared using the citrate process as described above in Example 10. A pattern of sharp Raman peaks characteristic of DTP indicates that the fractal aggregates substantially enhanced the Raman signals produced by the DTP. This study demonstrated that the fractal aggregates used to coat gold-covered slides were effective in enhancing Raman signals.

[0269] To derivatize the slides with fractal structures, we covered the portion of the slide to be so derivatized with solution of silver colloid and NaCl at a concentration of

about 60 mM to about 120 mM. We then permitted the silver fractal aggregates to adhere to the gold surface.

[0270] FIG. 16c depicts the Raman spectrum derived from a gold-covered slide having silver fractal aggregates thereon without any receptor. We then rinsed the fractal-derivatized substrate overnight with saturated solution of NaCl in water, followed by rinsing with triple distilled-deionized water to wash away non-adherent fractal aggregates. The slide was then air dried.

[0271] FIG. 16d depicts Raman spectrum of a slide washed in the above described fashion. The graph shows small changes in intensity that are unrelated to the presence of a receptor or an analyte. The pattern is characteristic of slides produced in this fashion, and is reproducible between slides. This process removed remaining unbound fractal aggregates and the reagents and contaminants present in the colloid.

[0272] The resulting fractal-derivatized substrate was used for the attachment of a receptor molecule, reduced glutathione. A solution of reduced glutathione was prepared by dissolving commercially available reduced glutathione (Sigma Chemical Co., St. Louis Mo.) in triple distilled-deionized water to a final concentration of 100 mg/mL. The solution of reduced glutathione was applied to the fractal-derivatized substrate and was permitted to adhere for a period of 30 minutes at room temperature (about 22° C.). After that time, the substrate was rinsed with water to remove unbound reduced glutathione. After washing, the substrate was air dried for 10 minutes.

[0273] At this point, a Raman spectrum of the substrate was obtained, and showed the characteristic pattern of reduced glutathione. FIG. 16e depicts a Raman spectrum of reduced glutathione attached to a silver fractal-derivatized gold-coated substrate. A sharp peak in Raman signal was observed at about 650 cm^{-1} , characteristic of reduced glutathione. This experiment demonstrated that reduced glutathione (a "receptor") was attached to a surface having fractal aggregates sufficiently near to enhance Raman signals from the reduced glutathione.

[0274] Subsequently, we extensively rinsed the glutathione-coated slide with triple-distilled, deionized water. FIG. 16f depicts the Raman spectrum obtained after rinsing and drying the slide. The characteristic Raman peak of reduced glutathione at about 650 cm^{-1} is present, and has about the same magnitude as in FIG. 16e. From this study, we conclude that the receptor (glutathione) is firmly attached to the substrate, and is sufficiently close to the fractal aggregates to substantially enhance the Raman signals generated by glutathione.

[0275] After preparation as described above, the substrate was exposed to a solution comprising glutathione S-transferase (Sigma Chemical Co., St. Louis, Mo.; "GST") at a concentration of 20 mg/mL in a buffer comprising 10 mM HEPES (Sigma Chemical Co.), 100 mM NaCl, pH 7.0. The GST was permitted to adhere to the reduced glutathione for a period of 5 minutes and then the Raman spectrum was acquired.

[0276] FIG. 16g depicts the Raman spectrum obtained after addition of GST. The Raman peak characteristic of glutathione is present at about 650 cm^{-1} . In addition, several other peaks are present. These peaks can be used to detect the presence of GST.

[0277] We found that in the absence of enhancing structures, GST alone was not detected. In the presence of fractal enhancing structures, however, glutathione S-transferase did result in a detectable Raman signal. Moreover, in the presence of both enhancing structures and glutathione, GST produced a Raman signal different from that of either glutathione alone or GST alone.

[0278] These results show that reduced glutathione can be detected in the presence of fractal aggregates. These results also show that a protein analyte, GST, can be detected, and that GST can be identified by Raman spectroscopy in the presence of reduced glutathione attached to fractal structures.

[0279] In other embodiments of this invention, polymers comprising glutathione can be provided near fractal aggregates. In certain of these embodiments, a polymeric structure can have glutathione side chains, attached by way of the glycine residues, or alternatively, by SH groups. In these embodiments, the polymer can have the appearance of a "bottle brush", having a plurality of glutathione chains available for association with GST.

[0280] In other embodiments, a single Gly-Cys-Glu terminus can be provided, on a long chain polymer. In these embodiments, there need not be a plurality of glutathione moieties. These embodiments comprising bottle brush or linear reduced glutathione can provide the receptors with sufficiently long linkers to permit the association of the glutathione moiety and the binding site of GST.

EXAMPLE 15

Fractal-Derivatized Substrate Having Gly-Cys Receptors for Glutathione S-Transferase

[0281] We performed additional experiments as described above in Example 14 except that instead of using reduced glutathione, we used the dipeptide glutathione fragment, Gly-Cys. Slides having Gly-Cys were prepared as described above for reduced glutathione. We found that the Raman signal observed for Gly-Cys-glutathione S-transferase was different than for either Gly-Cys or glutathione S-transferase alone. These results indicate that glutathione S-transferase can be detected using Raman spectroscopy as part of a complex with Gly-Cys.

EXAMPLE 16

Fractal-Derivatized Substrate Having Cys-Glu Receptors for Glutathione S-Transferase

[0282] We performed additional experiments as described above in Example 14 except that instead of using reduced glutathione, we used the dipeptide glutathione fragment, Cys-Glu. Slides having Cys-Glu were prepared as described above for reduced glutathione. We found that the Raman signal observed for Cys-Glu-glutathione S-transferase was different than for either Cys-Glu or glutathione S-transferase alone. These results indicate that glutathione S-transferase can be detected using Raman spectroscopy as part of a complex with Cys-Glu.

EXAMPLE 17

Fractal-Derivatized Substrate Having Cysteine Receptors for Glutathione S-Transferase

[0283] We performed additional experiments as described above in Example 14 except that instead of using reduced

glutathione, we used the amino acid Cysteine (Cys). Slides having Cys were prepared as described above for reduced glutathione. We found that the Raman signal observed for Cys-glutathione S-transferase was different than for either Cys or glutathione S-transferase alone. These results indicate that glutathione S-transferase can be detected using Raman spectroscopy as part of a complex with Cysteine.

EXAMPLE 18

Fractal Enhancement of Rhodamine Detection by Raman Spectroscopy

[0284] In another series of studies, the dye rhodamine was used to test the ability of fractal aggregates to enhance Raman spectroscopic detection. In one study, we applied a solution of rhodamine (10^{-16} M; "R6G") to an aluminum foil surface having silver fractal enhancing structures thereon. FIG. 17a depicts the Raman spectrum obtained for this preparation. No Raman signal characteristic of rhodamine was observed.

[0285] We also obtained the Raman spectrum of a solution of R6G in the presence of water on the surface of a piece of aluminum foil not having any fractal structures thereon. FIG. 17b depicts the Raman spectrum of this preparation. As with FIG. 17a, no Raman spectrum characteristic of R6G was observed.

[0286] We also obtained the Raman spectrum of a sample of R6G on a piece of aluminum foil that had been prepared by the addition of silver fractal enhancing structures as described above. FIG. 17c shows that in the presence of enhancing structures, a sharp peak at about 550 cm^{-1} was observed. This Raman spectral feature is characteristic of rhodamine.

[0287] This study indicates that using the fractal derivatized devices and methods of this invention, a molecule can be detected in concentrations as low as 10^{-16} M.

EXAMPLE 19

Antigen as Receptor for Detection of Antibodies by Raman Spectroscopy

[0288] To detect specific antibodies raised against 2,4 di-nitrophenol (2,4-DNP; "DNP"), substrates derivatized with silver or gold enhancing structures are prepared according to methods described above. The substrate has receptors comprising Cys-N-DNP attached to the substrate using the HS group of Cysteine, so that the DNP moiety of the receptor extends above the surface of the substrate. The substrate with receptor is then washed with NaCl to remove non-bound materials. Monoclonal or polyclonal antibodies raised against DNP are then applied to the substrate and are permitted to become associated with the DNP. The conditions of this antibody-antigen binding are known in the art and need not be described herein. After a period of time has elapsed to permit binding of anti-DNP antibody to the receptor, the substrate is washed with triple distilled, deionized water to remove unbound antibody.

[0289] Raman spectra are obtained at each step of this procedure. In the absence of receptor, the substrate having enhancing structures thereon show no Raman signal. Receptors associated with enhancing structures show a Raman spectrum characteristic for the Cys-N-DNP. When anti-DNP

antibodies associate with the Cys-N-DNP, the Raman spectrum changes, and is identical to neither the Cys-N-DNP nor the anti-DNP antibody alone. Control experiments in which the receptor is cysteine or glutathione do not produce a Raman signal characteristic of receptor anti-DNP antibody association. Additional controls include the use of $\text{NH}_3\text{—CH}_2\text{CH}_2\text{—SH}$. Anti-DNP antibodies do not specifically bind to $\text{NH}_3\text{—CH}_2\text{—CH}_2\text{—SH}$ and thus, the Raman signal generated by $\text{NH}_3\text{—CH}_2\text{—CH}_2\text{—SH}$ will be unaltered in the presence of an anti-DNP antibody. Thus these strategies provide methods for detecting specific antigen-antibody interactions by Raman spectroscopy.

[0290] V. Passivation of SERS-Active Surfaces

[0291] It has been recognized for a long time that analyte detection and quantitative measurement using Surface Enhanced Raman Spectroscopy (SERS) have a number of advantages, including little or no sample preparation, lack of a need for labels or tags, high sensitivity, and an ability to obtain information about chemical composition of a bound material. A large variety of enhancing surfaces, such as roughen metal electrodes, ablated metal foils, metal vapor or particles deposited on various substrates have been proposed. However, poor reproducibility of prior art enhancing surfaces and the lack of reproducibility in currently available SERS-based measurements in general, present a challenge for making practical use of SERS. Approaches disclosed herein employ receptors attached to enhancing surfaces, and also include surfaces which are passivated to decrease analyte binding directly to the surface. As used herein, the term “passivated surface” means a surface treated with a passivating agent. The term “passivating agent” is an agent that upon application to a surface, decreases the direct attachment of a molecule to that surface. In these situations, the analyte is bound more to the receptors, and thus, receptor-based selectivity of analytes can be increased. This approach can allow one to reproducibly and quantitatively detect analytes using SERS.

[0292] As applied to SERS, passivation can be accomplished by treatment of the metal surface with an agent to decrease binding of the analyte molecules and other compounds directly to the surface. Because binding of many compounds to a metal surface can be irreversible, passivation also can allow using the same enhancing surface for analyte measurements several times or can be used as a sensor. According to this invention, detection and quantitative measurements of a variety of analytes can be achieved using the passivated enhancing surfaces with attached receptors. Because binding of an analyte directly to an enhancing surface can be decreased by passivating agents, when receptors are present, the analyte can bind to the receptor, and not via non-specific or random binding that can occur in the absence of a passivating agent. In some embodiments, the receptor can be either a high selectivity receptor or a low selectivity receptor. In some cases, receptor molecules attached to the enhancing surfaces can serve simultaneously as a passivating agent.

[0293] FIGS. 18a-18d depict embodiments of this invention. FIG. 18a depicts an embodiment 1800 having a substrate 1804 having a surface 1808 with areas of roughness 1812 thereon. Areas of roughness 1812 maybe fractal aggregates, or any other type of roughness that can permit SERS methods to be used to detect an analyte. FIG. 18b

depicts an embodiment such as in FIG. 18a having receptors 1816 attached both to the rough areas 1812 and to the surface 1808. FIG. 18c depicts an embodiment as in FIGS. 18a and 18b additionally having a passivating material 1820 attached to both rough areas 1812 and to the surface 1808. FIG. 18d depicts an embodiment as in FIGS. 18a-18c additionally having an analyte 1824 shown associated with receptors 1816.

[0294] FIGS. 19a-19d depict alternative embodiments 1900 of this invention. FIG. 19a depicts a situation as described above for FIG. 18a. FIG. 19b depicts a situation similar to that depicted in FIG. 18b, except that receptors 1816 are associated with surface 1808 by way of polymer strands 1928. FIG. 19c depicts an embodiment similar to that of FIG. 19b, having passivating material 1820 being present. FIG. 19d depicts an embodiment similar to that depicted in FIG. 18d, except that the receptors 1816 are associated to the surface 1808 via polymer strands 1928.

[0295] A. Detection and Measurement of Analytes Using Passivated SERS-Active Surfaces with Receptors of High Selectivity

[0296] In many cases it can be desirable to use receptor of high selectivity, meaning that this receptor specifically binds the analyte of interest. Highly selective binding can decrease the number of “false positive” signals where the Raman signal of one analyte share common features with the Raman signal of another analyte present in a mixture of analytes. For example, if a mixture of analytes contains two similar proteins, having similar amino acid compositions, the Raman signals generated by each protein may have significantly similar Raman spectra. Thus, to separately detect such proteins, selective receptors can be very useful. Selective receptor-analyte complexes can be formed, for example, when various antibodies and antibody-like proteins are used to provide highly selective binding of antigens, or when proteins whose function is binding of particular compounds or other proteins are used. Other examples of selective binding can be in cases when oligonucleotides complementary to other oligonucleotides, or DNA and DNA-binding proteins are used. A large number of high selectivity receptors and corresponding analytes are well known in the art, and any such high selectivity receptor/analyte pair can be advantageously used in the methods of this invention. All such pairs are included within the scope of this invention.

[0297] The detection of analytes using highly selective receptors can be achieved with receptors that are attached to a metal enhancing surface via attachment chemistry utilizing one or more strategies. In one strategy, a receptor can be prepared or chosen to have free SH or readily accessible disulfide group(s) or other group(s) with high affinity towards metal surfaces. The examples of such receptors are DNA oligomers having a linker and thiol group at the end of the linker. The attachment of such DNA oligomers to metal surfaces is well known to those skillful in the art. In this invention, this oligomers are either supplemented with a passivating agent prior to their attachment, or such passivating agent is added to the surface with DNA attached to minimize any unspecific binding of DNA and other compounds to the metal surface. When a protein, e.g., antibody, is used as a specific receptor, this protein can have Cys residue(s) on its surface. In this case, the protein can be applied on an enhancing metal surface and a thiol group can

provide for attachment to the surface. In cases when a protein receptor is devoid of such Cys residue(s), the protein can be chemically modified to generate a SH-group on its surface. This modification can be performed using commercially available reagents provided by Molecular Probes (Eugene, Oreg.). Another approach for the attachment of a protein to metal surfaces can utilize insertion of a peptide or a residue containing either natural or artificial amino acids having groups with high affinity to such surfaces in their side chain using genetic engineering. This approach is also well known to those skillful in the art. In this invention, a protein receptor having on its surface a group capable of sufficiently tight binding to a metal surface is either supplemented with a passivating agent prior to attachment, or such passivating agent is added to the surface with the attached receptor. Another strategy for the attachment of highly selective receptors can utilize small linkers. These linkers have a group capable of the attachment of the linker to a metal surface on one end, and a group capable of attachment of a receptor on the other end. Such linkers, e.g., dithiobis(succinimidyl propionate), dimethyl 3,3'-dithiobispropionimidate $\cdot 2\text{HCl}$, 3,3'-dithiobis(sulfosuccinimidyl propionate), are commercially available from PIERCE (Rockford, Ill.). Also, the synthesis of such linkers capable of attachment to with metal surfaces and to a protein is described in "Capacitative Monitoring of Protein Immobilization and Antigen-Antibody Reactions on Monomolecular Alkylthiol Films on Gold Electrodes" V. M. Mirsky, M. Riepl and O. S. Wolfbeis, *Biosensors and Bioelectronics*, v.12(9-10): 977-989(1997), incorporated herein fully by reference. The attachment of these linkers to metal surfaces can be achieved by addition of such a linker at a concentration in the millimolar range on the surface and incubation for several minutes to several hours at room temperature. Passivation of the surface can be desirable after removal of the non-reacted linker from the surface by washing with triply distilled, de-ionized water. In systems in which amino groups are involved in receptor/analyte binding are used, the passivating agent can desirably be chosen that does not contain an amino groups, e.g., 2-mercaptoethanol, mercaptoacetic acid, mercaptophenol, mercaptobenzoic acid and the like. Linkers attached to the metal surface can react with amino groups of proteins providing their attachment to metal surfaces. Conditions for such attachment are described, for example, in Mirsky et al, supra, incorporated herein fully by reference.

[0298] B. Detection and Measurement of Analytes Using Passivated SERS-Active Surfaces with Low Selectivity

[0299] In many cases it may be desirable to use a surface having low selectivity, meaning that these surfaces can retain various different compounds having in common one or more specific chemical or physical properties. Low-selectivity receptors and surfaces can permit simultaneous detection and quantification of different analytes, so long as those analytes have at least one Raman spectral feature that is sufficiently different from the other analyte(s) present in the adsorbed mixture.

[0300] Low selectivity surfaces can include relatively non-specific receptors, or can include compounds having a chemical group or groups, including NH_2 , C(O)OH , SH, CN, OH, C(O)NH_2 , C(O)Cl , which can have affinity to a variety of chemical groups. For example, surfaces can have, for example, NH_2 , C(O)OH , SH, CN, OH, C(O)NH_2 ,

C(O)Cl or disulfide group(s). By way of example only, low-affinity receptors of this invention include acetylcysteine, glutathione, mercaptosuccinic acid, purine, uracil, NADP, and mercaptopurine. These compounds can be used for detecting other molecules according to the following Table 1.

TABLE 1

Low-Specificity Receptors for Analyte Detection By SERS	
Receptor Molecule	Analyte Detected
mercaptosuccinic acid	purine
acetylcysteine	purine
mercaptosuccinic acid	uracil
acetylcysteine	creatinine
acetylcysteine	uracil
mercaptosuccinic acid	NADP
mercaptopurine	succinic acid

[0301] It can be readily appreciated that the receptor molecules and analytes can be reversed, so that to detect acetylcysteine, one can use purine, to detect uracil, one can use mercaptosuccinic acid. Other such receptor/analyte pairs can be selected based upon physical and chemical properties of the compounds, which are known in the art.

[0302] Various polyoxyethelenes, crown ethers, cryptates, polyoxyethelenes in which NH is instead of oxygen can also be used as receptors to make low selectivity surfaces.

[0303] Other examples of surfaces having low selectivity include one or more hydrophobic layers, such as self-assembled monolayers of alkylthiols or disulfides which retain hydrophobic compounds. Yet other examples include one or more layers of lipid or lipid-like molecules that can be useful for retaining molecules having at least one hydrophobic portion. It can be appreciated that a wide variety of hydrophobic surfaces can retain molecules which may have overall hydrophilic properties, so long as the molecule has at least one hydrophobic portion that can interact with the hydrophobic surface. For example, hydrophobic surfaces can be useful to interact with amphipathic substances, including, for example lipid glycerides, which have a hydrophobic portion (lipid portion) and a hydrophilic portion (glycerol). In general, low selectivity surfaces are particularly well suited for purification of various compounds in the art of liquid chromatography, and those skillful in this art can readily select desirable physico-chemical properties for such a surface to have an affinity for a given known analyte of interest.

[0304] The major advantages of low selectivity receptors include ready availability, low cost, suitability for use with both hydrophilic solvents (e.g., water) and hydrophobic solvents (e.g., organic solvents), and can be used at elevated temperatures. It can be appreciated that the use of low-selectivity surfaces might associate with a number of different analytes. SERS can be used to detect different analytes on a surface because different compounds have different chemical structure, and therefore, can have distinct Raman spectral features. Therefore, unique Raman features can be used to detect and quantify the analyte(s) of interest despite the presence of other compounds that can exhibit Raman shifts, that are present on the surface. Thus, SERS can be useful to avoid false positives when a sample contains

complex mixtures of analytes. These false positives include signals generated by compounds which are associated with the surface and obscure the detection of the analyte of interest, so that instead of detecting the desired analyte, the obscuring compounds are detected instead.

[0305] In alternative embodiments of this invention, low selectivity receptors can be attached to a polymer. The polymer can have a backbone with side chains. The backbone can be composed of carbon atoms or can be a chain having carbon atoms and nitrogen or oxygen atoms. Alternatively, it can have silicon atoms in addition to carbon atoms, or it can be of only silicon atoms (these chains are typically short, i.e., less than 6 monomers) or be composed of Si and O atoms. Polymers having other combinations of atoms in backbone can be also used. The side chains can be used to attach the polymer to an enhancing surface and to attach a receptor. By means of example only, a polymer having carbon based backbone and amino groups in its side chains can be used to simultaneously provide binding of the polymer to a metal surface (e.g., gold or silver surface of nanoparticles) and to bind compounds having carboxylic groups or other negatively charged groups. Alternatively, polymers that do not have chemical groups specifically chosen to provide chemical binding to the metal surfaces can be also used. In this case, it can be desirable having polymers of substantial length to provide substantial physical adsorption of the polymer to a metal surface. The length of the polymer chains in such case is desirable to be at least 10 monomers. The upper limit for the length of such polymers, as well as for those having chemical groups with affinity to metal surfaces, in general, is desirable to not exceed 10,000,000 monomers to avoid problems of low rate of diffusion for analytes. Polymers having thiol, amide, amino, carboxyl, nitril, hydroxyl, or other chemical groups as side chain are well known to those skillful in the art and can be either obtained from commercial vendors or synthesized. It can be desirable to passivate metal enhancing surfaces having such polymers attached with small molecular weight passivating agents, including by way of example, 2-mercaptoethanol, ethanedithiol, mercaptoethylamine, cysteine, cystine or other small molecules containing mercapto-, cyano- or any other group having sufficiently high affinity to enhancing surfaces. The passivating agent with sufficiently high affinity for an enhancing surface can form a layer on the enhancing surface that cannot be removed by washing the passivated substrate under conditions used for Raman spectroscopic analysis. The passivating agent can decrease direct association of analytes with an enhancing surface, thereby decreasing non-specific binding of undesired analytes. However, the analyte of interest can be bound to receptors for that analyte, permitting detection by Raman spectroscopic methods.

[0306] It can be desirable to select passivating agents that themselves provide either weak Raman signals in the regions of the spectra where a desired analyte provides strong signals. In particular, it can be desirable to use passivating agents that have less than about 10 major Raman spectral features in the spectral region from about 10 cm^{-1} to about 4000 cm^{-1} . A major Raman spectral feature is one defined herein to be a line having a signal intensity comparable to that of either a receptor or an analyte molecule. However, it can be appreciated that passivating agents having major Raman features can be used if those features

are in different portions of the spectrum from that in which the analyte or receptor generates Raman signals.

[0307] In general, to passivate an enhancing surface, a clean surface can be exposed to a passivating agent in a solvent appropriate for dissolving the passivating agent. For hydrophilic passivating agents, water or other polar solvent can be used, including water, isopropanol and the like. For non-polar passivating agents, non-polar solvents can be used, including hexane and the like. The solution of passivating agent and solvent is applied to the enhancing surface for a period of time between about 1 minute and several days. In embodiments where self-assembled passivating layers are desired, the incubation period may be for several hours to several days.

[0308] Alternatively, a passivating agent can be added to a substrate with receptor molecules present in the solution. Additionally, a passivating agent can be added to a substrate after or during incubation of the substrate with a polymer.

EXAMPLE 20

Control of Completeness of Passivation

[0309] An enhancing surface (e.g., a slide) having fractal colloid silver aggregates attached to a gold surface was prepared as described above. The slide was washed with triply distilled, de-ionized water and dried with an absorbent light-duty wiper. When 50 microliter of a 1 mM purine solution in water is applied on such a slide, purine binds to the metal surface, as is evident from characteristic Raman spectrum of purine under SERS conditions obtained using Chromex 2000 Raman Spectrometer (Chromex, Albuquerque, N.M.). The conditions for measurements were: excitation wavelength: 785 nm, laser power: 100 mW, integration time: 20 sec. The binding of purine to a non-passivated surface was found to be substantially irreversible; washing the slide with water and/or iso-propanol did not result in substantial change in the Raman spectrum indicating that purine remained bound to the slide. Similar binding was observed when the same experiment was performed using Rhodamine 6G at concentration 1 μM or 2,2'-dithiobis(dinitrophenol) (DTP) prepared by 100 times dilution of saturated DTP solution in water.

[0310] A test for completeness of passivation is based upon the property of a passivating agent to decrease direct interaction of a compound with an enhancing surface. When passivation is complete, less irreversible binding of compounds occurs. Completeness of passivation can be determined by applying a solution of purine, Rhodamine 6G, or DTP to a passivated slide, and then measuring Raman spectra before and after washing as described above. When complete passivation is achieved, no Raman signal of purine, or Rhodamine 6G, or DTP can be observed after washing the slide. For example, treatment of the slide with 1 M L-cysteine, or 2-mercaptoethanol, or ethanedithiol, or mercaptoethylamine in water at room temperature for about 30 seconds produced substantially complete passivation of the slide. In the case of DTP, washing is desirable to be performed within a few minutes after DTP application. Longer incubation with DTP can result in irreversible attachment of DTP, even in the presence of a passivating agent.

[0311] Although passivation decreases direct association of an analyte with an enhancing surface, the passivating

agent desirably can be selected to not interfere with the interaction between the analyte and a receptor used to bind with the analyte. Thus, passivation decreases non-selective analyte binding without adversely affecting selective, and/or controllable analyte binding.

[0312] In some situations, it can sufficient if passivation results in a decrease in the intensity of an analyte's signal on an enhancing surface in the absence of an analyte receptor to about 50% of the initial intensity after between about 5-20, 5-10, or about 5-7 washing steps. Alternatively, passivation may be useful if the intensity of a signal produced by an analyte decreases to about 50% of the initial intensity after 3 washing steps. For other uses, passivation can be considered sufficient if 50% of the initial intensity remains after only 1 washing step. For yet other uses, passivation can be sufficient if 25% of the initial signal remains after 1 wash (i.e., about 75% is lost), and in still other applications, passivation can be considered complete if less than 10% of the initial signal remains after 1 washing step. For more complete passivation, it can be desirable for less than about 5% of the initial signal to remain after a single washing step, and in some cases, it can be desirable for only about 1% of the initial signal to remain after a single washing step. For especially rare analytes, or for analytes having intrinsically high binding to the enhancing surface, it can be desirable to passivate surfaces so that less than about 1% of the initial signal remains after 1 wash step. It can be especially desirable that only about 0.01% of the original analyte signal remains after a single washing step.

EXAMPLE 21

Quantitative Measurements of Purine Using an Enhancing Surface Passivated with L-Cysteine Having Acetylcysteine as a Low Selectivity Receptor

[0313] A slide having fractal colloid silver aggregates attached to gold surface ("fractal slide") was prepared as described above. The slide was washed with triply distilled, deionized water and dried with an absorbent light-duty wiper. The attachment of receptor, acetylcysteine was performed as follows: A 200 μL aliquot of a 1 M solution of acetylcysteine in water was applied for 1 min on the fractal slide at room temperature. Non-reacted acetylcysteine was washed with 15 mL of triply distilled, de-ionized water and the slide with attached receptor was dried with a wiper. Then, passivation was performed using L-cysteine as a passivating agent: 200 μL of 1 M solution of L-cysteine in water was applied for 30 seconds and the fractal slide, after which the slide was washed again and dried. Such a passivation procedure yielded a substantially passivated slide as (see Example 20).

[0314] Each step of the procedure was monitored by measuring Raman spectra. When a 50 μL aliquot of purine solution is applied on the slide, characteristic Raman spectral features of purine appeared. The intensity of these spectral features depended upon the concentration of purine in the aliquot. The intensity was quantitatively determined by taking into account the intensity of background. The Raman spectral feature appears as an increase in the intensity of the Raman signal at a particular wave number. The increase in intensity was expressed as the ratio of the intensity of the Raman peak height minus background (ΔI)

to the intensity of background. This measure of the signal of a compound under SERS conditions is independent from the enhancing properties of the surface. Other means for detection of contribution of an analyte to the total Raman spectra can be used for quantitative detection of the analyte. These approaches for quantitative analysis of spectra are well known to those skillful in the art.

[0315] The passivated slide with analyte attached to an purine receptor was washed after the measurement, and the signals generated by purine substantially disappeared. Re-addition of purine resulted in reappearance of the Raman signal for purine, and repeated measurements so made produced reproducible signals on the same slide, typically for at least 2-3 repetitions. In some experiments, no substantial change in reproducibility of the signals were observed after more then 100 measurement/washing cycles. The detection of purine in a 5 μL sample containing purine at concentration as low as 50 nM can be carried out using 200 seconds integration time. At concentrations higher than 1 μM , quantitative detection with an integration time of about 20 seconds is acceptable.

[0316] FIG. 20 depicts a typical Raman spectrum obtained for purine on a fractal slide passivated as described above. Intensity of the Raman signal is depicted on the vertical axis, and the Raman shift (in cm^{-1}) is depicted on the horizontal axis. Spectral features A and B are characteristic of purine.

[0317] FIG. 20b depicts the results of several experiments in which purine is detected after being applied to a passivated fractal slide as described above. The vertical axis represents the relative intensity of ΔI :background intensity. The horizontal axis represents the concentration of purine in an aliquot applied to the fractal slide. With no added purine, ΔI is minimal, and at 1 mM purine, the relative intensity is about 0.3. Increasing the amount of purine increases the relative intensity in a concentration-dependent fashion. Even at 100 mM, no saturation is detected, meaning that one can quantify purine even at larger concentrations than 100 mM. For samples that have substantially higher amounts of purine, dilution of the sample prior to analysis can ensure that the amount of purine can be quantified.

EXAMPLE 22

Quantitative Measurements of Purine Using an Enhancing Surface Passivated with 2-Mercaptoethanol Having Succinic Acid as a Low Selectivity Receptor

[0318] A fractal slide was prepared as described above. The slide was washed with triply distilled, de-ionized water and dried with an absorbent light-duty wiper. The attachment of receptor, succinic acid, was performed simultaneously with passivation using 2-mercaptoethanol as follows: A 200 μL aliquot of the mixture containing 190 μL of 1 M solution of succinic acid in water and 10 microliters of 1 M 2-mercaptoethanol in water (molar ratio of the receptor to the passivating agent 20:1) was applied for 1 min on the fractal slide at room temperature. Non-reacted material was washed with 15 mL of triply distilled, deionized water and the slide with attached receptor was dried with a wiper. Each step was monitored by measuring Raman spectra.

[0319] A 50 μL aliquot of purine solution was applied on the slide, and characteristic Raman spectral features of

purine appeared. The intensity of these features was dependent upon the concentration of purine in the aliquot. The intensity was quantified as above. Slides were washed after the measurement are made, and the features of purine diminished. Passivation was considered complete when the signal for purine disappeared with washing. Measurements of purine were repeated on the same slide at least 2-3 times. In some measurements, no substantial changes in the intensities of Raman spectral features characteristic of purine were observed after more than 100 measurement/washing cycles. **FIG. 21** depicts results of an experiment as described above. The vertical axis represents the intensity of Raman signals, and the horizontal axis represents the Raman shift in cm^{-1} . Graph A represents the Raman signal obtained from a fractal slide without passivation, receptor or purine. No Raman signals characteristic of purine are present. Graph C depicts a fractal slide as in graph A, with the addition of 2-mercaptoethanol as a passivating agent, M-succinic acid as a receptor, and purine as an analyte. Spectral features E and F are characteristic of purine. Graph B is of the same slide as in graph C after washing for 1 minute. Note that the features E and F of purine are absent. Graph D is of the same slide but measured 1 day after graph B. Note that no features E or F of purine are present, but the feature of M-succinic acid is present, indicating that the receptor has not been washed off.

[0320] A calibration curve was obtained for both purine and uracil. **FIG. 22** depicts a graph of the concentration of analyte (horizontal axis) versus $\Delta I/\text{background}$. Filled circles represent data obtained from a fractal slide exposed to a mixture of 195 μL of a 1 mM succinic acid solution and 5 μL of 1 M 2-mercaptoethanol, followed by exposure to purine at the concentrations indicated. At concentrations of purine below about 10^{-8} M, little signal was detected. At a concentration of about 10^{-8} M, a signal for purine was detectable, and increasing the concentration of purine increased the intensity of the signal, until a concentration of about 10^{-4} M was used. Increasing the concentration of purine above 10^{-4} M did not increase the intensity of the signal. In an experiment otherwise identical, except that 10 μL of 2-mercaptoethanol was used to passivate the slide (stars), similar results were obtained, except that the maximum signal detected was about $\frac{1}{2}$ of that obtained using a slide passivated with $\frac{1}{2}$ the 2-mercaptoethanol. Thus, the ratio of receptor to passivating agent was decreased by $\frac{1}{2}$. This study also indicates that detection was accomplished over a range from about 10^{-8} M to about 10^{-4} M. When the slide was treated with receptor and passivating agent with a molar ratio of receptor to passivating agent of $\frac{1}{2}$ that described above (the molar ratio of the receptor to the passivating agent was 10:1), the intensity of the Raman spectral features characteristic of purine were about $\frac{1}{2}$ of those observed over the range of purine concentrations tested. This study demonstrated a quantitative relationship between the amount of receptor used and the amount of analyte detected.

EXAMPLE 23

Quantitative Measurements of Uracil Using an Enhancing Surface Passivated with 2-Mercaptoethanol Having Mercaptosuccinic Acid as a Low Selectivity Receptor

[0321] Slides having succinic acid as a receptor and 2-mercaptoethanol as a passivating agent were prepared

using methods as described in Example 22. The molar ratio of the receptor to the passivating agent was 20:1. When a 50 μL aliquot of a uracil solution was applied to the slide, characteristic Raman spectral features of uracil appeared. The intensity of these features depended upon the concentration of uracil in the aliquot. The intensity was quantified as above. The slide was washed after the measurement, and when passivation was complete, the features characteristic of uracil disappeared. Measurements of uracil on the same slide were repeated at least 2-3 times. A calibration curve obtained using the slide indicated that the detection of uracil in the range of about 10^{-4} M to about 10^{-2} M.

[0322] **FIG. 22** depicts results of this study. Filled squares represent the intensity of the Raman signal for uracil versus the concentration of uracil present in samples tested. At concentrations below about 10^{-4} M, little signal was detected, but uracil was detected over a range of concentrations from about 10^{-4} M to about 10^{-2} M.

EXAMPLE 24

Detection of Uracil in the Presence of Purine Using an Enhancing Surface Passivated with 2-Mercaptoethanol and Having Succinic Acid as a Low Selectivity Receptor

[0323] A fractal slide having succinic acid as a receptor and 2-mercaptoethanol as passivating agent was prepared using molar ratio of the receptor to the passivating agent 20:1 as described for Example 23. Application of a 50 μL aliquot containing 25 microliters of 10^{-6} M purine and 25 microliters of 10^{-2} M uracil resulted in Raman signals characteristic of uracil was readily detectable along with the signal of purine. When purine is present at higher concentration, i.e., upon application of a 50 μL aliquot containing 25 μL of 10^{-3} M purine and 25 μL of 10^{-2} M uracil, the Raman spectrum of uracil was seen only as a shoulder, whereas the signal of purine was clearly seen and was quantifiable. Quantitative detection of uracil was performed using spectral analysis procedures provided by standard software, e.g. GRAMS or IGOR. The conclusion from this experiment is that even though two analytes are both bound to the same, low selectivity surface, these analytes can be individually detected due to a difference in their Raman spectra and that sufficient resolution of the signals for each analyte were provided by SERS.

EXAMPLE 25

Quantitative Measurements of Creatinine Using an Enhancing Surface Passivated with L-Cysteine Having Acetylcysteine as a Low Selectivity Receptor

[0324] A fractal slide having acetylcysteine as a receptor and L-cysteine as a passivating agent was prepared as described in Example 20. When a 50 μL aliquot of creatinine solution in water was applied to the slide, characteristic features of creatinine appeared in the Raman spectra. The intensity of these bands was dependent upon the concentration of creatinine in the aliquot. The measurements were performed in the pH range from 4.4 to 8.7. The intensity of the signals at 849 cm^{-1} and/or at 679 cm^{-1} were quantitatively determined as described above. At a pH higher than 8, little creatinine was detected. At pH's in the

range of about 4.4 to less than about 8, creatinine was detected in the range of about 1-100 mM. The slide was washed after the measurements and the spectral features of creatinine disappeared. After repeated application of creatinine to the slide, measurements of creatinine were repeated. The calibration curve obtained indicated that the detection of creatinine could be quantified in the range of about 1 mM to about 100 mM.

[0325] Passivation can produce surfaces, using which, repeated, independent measurements of analytes can be carried out in a quantitative fashion. Thus, embodiments of this invention include systems having flow cells through which solutions containing analytes can be passed. Thus, multiple different solutions can be analyzed conveniently with a single passivated fractal slide having one type of receptor.

EXAMPLE 26

Flow-Through Device I for Raman Spectroscopic Analysis of Analytes

[0326] This invention also provides devices suitable for performing repeated Raman spectroscopic analyses in a flow-through format. FIG. 23 depicts an embodiment of this invention 2300 having a computer system 2304, a light source 2308 suitable for performing Raman spectroscopy, a detector 2312 suitable for detecting Raman signals. A beam of incident radiation 2316 emitted by light source 2308 is directed towards a flow cell 2322 having a wall 2324, a window 2320 being sufficiently transparent to the wavelengths of light in incident beam 2316. Within the interior of the flow cell, a surface 1804 comprises passivating agent 1820, rough areas 1812, receptors 1816 and analytes 1824. Together, these components can be considered as a detection portion 1826 of the detector system. Light scattered by analytes in detector portion 1826 passes back through window 2318 to form an output beam 2320, which is detected by detector 2312. Computer system 2304 analyzes the signals from detector 2312 and provides outputs to other components (not shown). A sample containing analytes 1824 is depicted flowing through flow cell 2322 in the direction 2332 indicated by the arrow. Some unbound analytes 1824 are shown in the flow stream, and some analytes 1824 are depicted associated with receptors 1816.

[0327] Flow can continue as measurements are made, or the flow can be stopped during measurements are being made. Washing steps can be carried out by replacing the sample containing analytes 1824 with solutions not containing analytes. Thus, the detection portion 1826 can be washed free of analyte. Additional samples can be provided through the flow cell 2322 for either repeated measurements of the same sample, or for the analysis of additional samples.

EXAMPLE 27

Flow-Through Device II for Raman Spectroscopic Analysis of Analytes

[0328] FIG. 24 depicts other embodiments of this invention that include flow-through devices as described above in Example 26 and an additional flow source 2436. Other elements of this embodiment are numbered the same as in FIG. 23. Because association of analytes to receptors can depend upon the conditions (e.g., pH, temperature, solvent,

salt concentration, etc), it is desirable to be able to vary the conditions under which analytes are detected. Using flow source 2436, a solvent can be introduced into flow cell 2322 having, for example, a different pH. In such a fashion, the conditions of association of analyte 1824 and receptors 1816 can be adjusted as desired.

[0329] VI Biochips for Characterizing Biological Processes (Diagnostic Biochips)

[0330] Additional embodiments of this invention relate to biochips for detecting specifically defined analytes, cells and cellular components that are characteristic of biological conditions and/or diseases.

[0331] In general, biochips of these embodiments include a substrate, Raman signal enhancing structures (nanoparticle structures, and/or fractal aggregates), and receptors near or attached to the Raman signal enhancing structure. For certain embodiments, a passivated substrate and/or enhancing structure may be desirable to increase the signal/noise ratio, thereby permitting more sensitive, accurate measurements of analytes. When an analyte of interest becomes associated with the receptor with specificity, the chip is read using a Raman reader to produce a Raman spectrum or portion thereof. By determining the magnitude of the Raman signals so generated, the amount and identity of the analyte is determined. By comparing the presence or absence of one or more analytes, the amounts of one or more analytes, and/or the ratios of one or more analytes, the biochips of this invention can be used to diagnose any physiological or pathophysiological condition.

[0332] A. Manufacture of Diagnostic Biochips

[0333] Biochip for such analysis can be composed of a substrate having an enhancing surface with attached receptors for desired analytes. Such receptors can be antibodies, analyte binding proteins or enzymes with appropriate binding specificity which are inactivated to avoid hydrolyzing the analyte, but retain the affinity towards their corresponding target analytes.

[0334] In the construction of a biochip, it is desirable to select receptors that have low molecular weights in order to allow maximal signal/noise ratio by permitting the maximum number of HEPC molecules to be retained at a spot. A large number of receptors for various analytes are commercially available or can be generated by such companies as Phyllos Inc, Cambridge Antibody Technology LTD, etc..

[0335] B. Attachment of Receptors to Substrates

[0336] Numerous methods are available in the art for attaching protein and non-protein receptors to solid phases or to surfaces. Methods are known for attaching proteins to gold surfaces. Minor adaptations of these methods without undue experimentation can be well suited to attaching proteins to silver surfaces. Additionally, a bifunctional linker can be used having one end with a free sulfhydryl (SH) group, and the other end having a free amino group. A gold or silver surface having nanoparticles can be covered with a molecular layer of thiol- and amino group-containing linkers on either side of an aliphatic spacer. Linkers can bind irreversibly to the metal surface via the SH group on the linker, leaving the amino group on the other end of the linker available for attachment to the receptor of interest. These methods are described further in the art (Mirsky et al.,

Capacitive Monitoring of Protein Immobilization and Antigen-Antibody Reactions on Monomolecular Alkylthiol Films on Gold Electrodes, Biosensors and Bioelectronics, 12(9-10):977-989 (1997)), incorporated herein fully by reference.

[0337] Alternatively, bis(sulfosuccinimidyl)suberate (Pierce) is another linker that can be used advantageously with protein receptors.

[0338] C. Uses of Diagnostic Biochips

[0339] It can be appreciated that any set of analytes, reflective of any cellular, tissue, organ or organismic process(es) can be advantageously employed with the biochips of this invention. Thus, biochips can incorporate any set of analytes that is desired. Further, biochips can be made that incorporate a plurality of different sets of receptors for analytes of interest, thereby permitting simultaneous analyses, and increasing the speed of physiological or pathophysiological diagnosis. For example, as further disclosed below, a biochip can be made that includes receptors for analytes reflective of cellular energetics, cellular oxidative stress, and inflammatory markers. Similarly, it may be desirable to provide a biochip that can be used to diagnose cancer and inflammatory status. The above are only examples for illustration only. Any set of analytes that reflects a biological process can be used with any other set of analytes, thereby providing simultaneous measurements of multiple biological processes.

[0340] Biochips can be made having a plurality of different locations, and each location may have a unique receptor type associated therewith. Thus, by positioning the Raman detector over an area having a unique receptor type, a plurality of different analytes may be assayed using the same biochip. Such biochips, their methods of manufacture and use, and detection of analytes are described in U.S. patent application Ser. No. 09/670,453, U.S. patent application Ser. No. 09/815,909, and U.S. patent application Ser. No. 09/925,189, each of these Patent Applications are herein fully incorporated by reference.

[0341] These embodiments relate to several biological processes of interest. Examples of analytes which can be quantitatively detected include, but are not limited to:

[0342] cAMP—a secondary messenger involved in the regulation of many intracellular processes;

[0343] serotonin—a neurotransmitter involved in a number of neurological conditions, such as depression;

[0344] MAO I & II (monoamine-oxidases)—the enzymes regulating the levels of certain neurotransmitters;

[0345] beta-amyloid peptide and TAU protein—important markers of Alzheimer's Disease;

[0346] Proprietary nucleic acid (DNA/RNA)—containing compounds recently associated with certain chronic human diseases;

[0347] PrP^{Sc}—an abnormal form of the prion protein, associated with prion diseases (such as Mad Cow Disease, transmitted through the consumption of infected meat).

[0348] In other embodiments, bioanalytes of interest include cAMP, serotonin, monoamine oxidase I, monoamine oxidase II, beta-amyloid peptide, Tau protein, PrP^{Sc}, ATP, ADP, AMP, enzymes involved in energy metabolism, calmodulin, calmodulin binding protein, heat-shock proteins, superoxide dismutase, glutathione peroxidase, reduced and oxidized glutathione, nitrotyrosine, FADH, NADH, pyruvate, acetyl Co-A, GTP, NADPH, NADPH oxido-reductase, catalase, cytochrome-A, cytochrome-B, cytochrome-C, beta-hydroxybutyrate, acetylacetate, lactate, glycerol 3-phosphate, glucose 6-phosphate, creatine phosphate, 1,3-diphosphoglycerate, phosphoenolpyruvic acid, acetylphosphate, UTP, CTP, dATP, dGTP, dTTP and dCTP.

[0349] In certain other embodiments, biochips can be assayed in a system that utilizes a commercial, off-the-shelf Raman spectrometer as a reader with minor modifications for positioning the chip and focusing on a spot. Other embodiments can use a commercial spectrometer with a commercially available, automated multiwell Raman reader.

[0350] In certain other embodiments, biochips can be monitored using a specialized, parallel Raman reader, such as described in U.S. patent application Ser. No. 09/939,887, incorporated herein fully by reference. Additionally, other types of Raman systems are available commercially, and can find use with the biochips of this invention.

[0351] Regardless of the particular type(s) of reader(s) used, information can be obtained that may include: (1) presence or absence of a particular analyte, (2) amounts of analytes present in the biological sample, and/or (3) ratios of amounts of analytes present. It can be appreciated that by selecting different biological samples, any of (1) to (3) above can be obtained and compared with information obtained from other biological samples. Such information can provide a "snapshot" of the physiological or pathophysiological state of an organism at a point in time. Additionally, analysis of samples obtained over time can provide information pertinent to changes in physiological or pathophysiological conditions as disease or treatment progresses. By obtaining information on biological samples from more than one source, one can determine relationships between the organism's different structural and/or functional parts. For example, by selecting biological samples from, for example the blood and the urine, one can determine the roles that the renal system has in handling excreted materials.

[0352] Moreover, in embodiments for experimental studies, other combinations of samples can be collected and relationships between biological processes carried out by different organs, tissues or cells can be determined. It can also be appreciated that by collecting biological samples over time, the time course of changes to a biological system can be obtained. Such time course studies can be beneficial for studies of, for example, metabolic processes, responses to disease and/or responses to therapy.

[0353] Some examples of biochips that are useful for quantitative detection of different biological phenomena of interest are provided below.

EXAMPLE 28

Cellular Bioenergetics Biochip™

[0354] In certain embodiments, a Cellular Bioenergetics Biochip™ can be used for measuring analytes including:

ATP, ADP, AMP, and key enzymes involved in energy metabolism. Living systems maintain a low level of entropy by maintaining themselves at a steady state. Such maintenance is achieved through the expenditure of energy. Cells convert energy-rich substrates such as glucose and lipids into various intermediates (such as pyruvate and acetyl CoA) and utilize cellular carriers of this energy (FADH, NADH) to allow their further conversion into readily available forms for consumption, such as adenosine triphosphate (ATP) or guanosine triphosphate (GTP). The maintenance of numerous physiological processes, such as muscle contraction, cellular transport and heat generation are dependant upon ATP generation and expenditure. Maintenance of order in the living state is also accomplished by the generation and use of reducing equivalents carried in the form of nicotinamide adenine dinucleotide phosphate (NADPH) for reductive synthetic reactions and various reductive dismutations and antioxidant protection. An example of the later processes involves the well-known pathway of oxygen reduction to superoxide, hydrogen peroxide and water via enzymes such as NADPH oxido-reductase, superoxide dismutase, and glutathione peroxidase or catalase. The reducing equivalents for these processes are generally contributed by NADPH.

[0355] Investigations into the origin of defects of cellular energetics have been a major theme of biochemistry for over 50 years. Delineating these defects holds promise for understanding the origin of numerous diseases, particularly those diseases associated with aging and degenerative diseases such as diabetes, heart disease, and cancer. Such diseases and associated conditions are increasing thought to involve defects of mitochondrial energy metabolism, the efficient utilization of oxygen and the excessive damage to tissues by oxygen radicals.

[0356] Enormous time and effort are expended by biochemical investigators using a variety of bioanalytical methods to study cellular energy metabolism. These involve numerous and disparate methods which range from using a simple spectrophotometer to more sophisticated methods such as radio-immunoassay, mass spectrometry and ELISA. A universal and integrated bioanalytical process for determining a large number of bioanalytes at one time using one universal platform and instrument can save labor and costs and therefore is of practical utility to the study of cellular energetics and other biomedical fields. The following invention provides such a universal platform, namely a biochip with receptors for various bio-analytes and a Raman spectrometer serving as a reader for detecting Raman lines from bioanalytes and their receptors on such a biochip.

[0357] In order to assess the status of energy metabolism is useful to know total quantities and the ratios of various biochemical substances that are involved in energy metabolism. For instance cellular energy charge, which cellular energy charge is an a major factor in the regulation of metabolic pathways that generate and use high energy phosphate groups. Cellular energy charge= $\frac{1}{2}([\text{ADP}] + 2[\text{ATP}]) / ([\text{AMP}] + [\text{ADP}] + [\text{ATP}])$.

[0358] The ratio ($[\text{creatine}]/[\text{creatine-phosphate}]$) is a useful indicator of phosphate energy status for tissues such as muscle, the ratio ($[\text{NADH}]/[\text{NAD}^+]$) can indicate mitochondrial redox status, and the ratio ($[\text{NADPH}]/[\text{NADP}^+]$) as

well as the ratio of glutathione (GSH) to oxidized glutathione (GSSG), ($[\text{GSH}]/[\text{GSSG}]$) can indicate cytosolic redox status.

[0359] The concomitant measurement of the levels of reduced and oxidized NAD, flavins, cytochromes B, C, A, ADP, oxygen, and substrates, such as beta-hydroxybutyrate, can be useful for characterization of oxidation-reduction status (states) of the mitochondrial electron transport chain (respiratory chain).

[0360] The oxidation-reduction status of tissues with respect to mitochondrial status or cytosolic status can be determined in humans and experimental animals by measuring respectively, ratios of ($[\text{beta-hydroxybutyrate}]/[\text{acetoacetate}]$) or ($[\text{pyruvate}]/[\text{lactate}]$) and comparing arterial levels to venous levels of these compounds. If one knows the ratios of these compounds before they enter a particular tissue (arterial levels) and compares these ratios to those ratios after leaving the tissue (venous levels), then the redox status of that tissue can be inferred (Aoki, T. T., Hormone-Fuel interrelationships in Normal, Fasting, and Diabetic Man, Joslin's Diabetes Mellitus, Alexander Marble, Leo Krall, Robert F. Bradley A. Richard Christlieb, and J. Stuart Soeldner, Lea & Febiger Publishers, Philadelphia 1985).

[0361] To complement the biochemical evaluation of redox status and other measurements of bioenergetics in cells and tissues it is also useful to measure the total levels of cellular mitochondria, in cells and tissues. Generally speaking, the number of mitochondria can be correlated with the capacity to generate energy, since most cellular ATP is generated by mitochondria. The number of mitochondria can be also be correlated with aerobic potential and oxygen utilization of cells or tissues. A biochip containing receptors with an affinity toward mitochondria allows their quantification. While mitochondria are of central interest in bioenergetics research, in order to characterize the relationships between energy supply and general health profile of a cell one can also quantify the number of other cellular organelles by using a biochip having receptors against constituents of the organelles.

[0362] All cells produce ATP used to transfer bond energy. ATP is used to produce other high energy phosphate compounds (HEPC) such as glycerol 3-phosphate, glucose 6-phosphate, creatine-phosphate, 1,3-diphosphoglycerate, phosphoenolpyruvic acid, acetyl phosphate. The measurements of cellular levels of these HEPC are important in the evaluation of metabolic pathways.

[0363] Other HEPC channel ATP energy into pathways used for biosynthetic purposes. Examples of these HEPC are the nucleoside 5'-triphosphates (such as UTP, GTP, CTP) and deoxynucleoside 5' triphosphates (dATP, dGTP, dTTP and dCTP). For instance, deoxynucleosides are important in the biosynthesis of DNA, UTP functions as an intermediate in the biosynthesis of polysaccharides, CTP in the biosynthesis of lipids, GTP in the biosynthesis of cellulose and proteins, and GTP, UTP and CTP in the biosynthesis of RNA. Measurements of such HEPC have practical utility in agricultural, industrial, and biomedical research and in medicine.

[0364] Measurement of the levels of energy-related bioanalytes (ERB) in physiological fluids, tissues, cells and cellular organelles can be performed by preparing samples using a variety of methods well known in the biochemical arts.

[0365] In the case of blood, an anti-coagulant such as heparin or EDTA can be added to the sample when it is drawn. Solutions of ERB are then analyzed by placing a known volume of whole blood on a suitably configured biochip. In some cases, it can be useful to separate out blood elements such as erythrocytes, leukocytes and platelets using centrifugation in or other separation techniques to separately analyze plasma and these various blood cells for the levels of ERB.

[0366] In certain embodiments, analytes useful for characterizing energetics include, without limitation, ATP, ADP, AMP, creatine, creatine-phosphate, lactic acid, acetyl-coenzyme A, NAD⁺, NADH, NADPH, NADP⁺, GTP, total mitochondria activity, beta-hydroxybutyrate (B-OHb), and acetoacetic acid (AcA).

[0367] The adenosine-containing compounds ATP, ADP and AMP are involved in many cellular processes, and can be easily detected using Raman spectroscopy. Creatine is a phosphate acceptor, creatine-phosphate is a phosphate donor. The ratio of creatine to creatine-phosphate, therefore, can reflect a cell, tissue, organ, or organism's overall energy status. Lactic acid can reflect anaerobic glycolysis and acetyl-CoA can reflect substrate availability for oxidative metabolism, such as via the Krebs cycle. NAD containing molecules are involved in many electron-transfer reactions, including cellular oxidative metabolic processes, and can be easily detected using Raman spectroscopy, due the presence of pyridine moieties. NADPH can be associated with glutathione metabolism and thus can reflect cellular reductive metabolic processes. The ratio of reduced glutathione to oxidized glutathione can be a significant indicator of a cell's oxidative/reductive status. B-OHb and AcA can reflect the state of electron transport systems.

EXAMPLE 29

Cancer Research Biochip™

[0368] A Cancer Research Biochip™ can be used for measuring numerous cancer-related analytes. For example, matrix metalloproteinases (MMPTs) are involved in metastasis. Many different biological materials are known to be associated with metastatic diseases. Those include cytokines, hormones, enzymes, a variety of gene products including those encoded by oncogenes. Any such material associated with metastasis is herein termed a "carcinophore." Carcinophores may be tumor specific or maybe generally associated with metastatic disease, either directly, or indirectly, through intermediates.

[0369] Matrix metalloproteinases (MMPs) are a family of zinc endoproteinase enzymes which degrade extracellular matrix tissue such as collagen and are implicated in a variety of inflammatory conditions ranging from asthma (Lee, YC et. al., 2001), heart failure (Lee, RT.,2001), rheumatoid arthritis (Honda, S. et. al., 2001) and cancer metastasis (Okada, N. 2001). Over 20 types of MMPs have been identified and the interactions and regulation of MMPs are complex and poorly understood. Improved methods for measuring MMPs could facilitate understanding MMPs and aid in the development of treatments for disease involving MMPs.

[0370] Methods for measuring individual MMPs (such as MMP-9) typically involve ELISA methods which require

labeling. Methods of this invention do not require labeling or ELISA methods and involves a device (a biochip) and a method for the measurement of multiple MMPs simultaneously.

[0371] A set of receptors, such as commercially available mouse or human-derived antibodies for MMPs are placed on a specially prepared substrate. Each type of receptor can be attached to a predetermined location on the substrate, so that positional information from the reader can be used to identify the particular receptor/analyte pair detected. A liquid specimen such as urine, blood or blood plasma or tissue homogenate is applied to the surface of the biochip. Analytes present in the specimen can become associated with the receptor and when placed in a reader, the presence and/or amount of that analyte can be determined.

[0372] To facilitate an understanding of regulation of MMPs such as inhibition or activity of MMPs, an additional set of receptors such as antibodies can be used to detect inhibitors of MMPs such as tissue-inhibitors of MMPs (TIMPs) or activators of MMPs such as cathepsins and plasminogen activators. These receptors could be placed on the same MMPs biochip (see example 1) or on a separate biochip.

[0373] Similarly a variety of other antibodies for cytokines such as IL-1, IL-2 and TNF-alpha can be placed on the same chip in order to observe correlations between the presence or absence of these agents with MMPs. Okada N, Ishida H, Murata N, Hashimoto D, Seyama Y, Kubota S., *Matrix metalloproteinase-2 and -9 in bile as a marker of liver metastasis in colorectal cancer. Biochem Biophys Res Commun.* 2001 October 19;288(1):212-6; Honda et al, *Expression of membrane-type 1 matrix metalloproteinase in rheumatoid synovial cells, Clin Exp Immunol.* 2001 October;126(1):131-6; Lee et al., *The involvement of matrix metalloproteinase-9 in airway inflammation of patients with acute asthma, Clin Exp Allergy.* Oct. 31, 2001(10):1623-30; Lee RT., *Matrix metalloproteinase inhibition and the prevention of heart failure. Trends Cardiovasc Med.* Jul. 11, 2001(5):202-5.

[0374] Receptors useful for detecting the presence and/or amount of MMPs and/or for regulation of MMPs include antibodies directed against Pro MMP-1, MMP-1, Pro MMP-9, MMP-9, MT1-MMPT, Pro MMP-2, and MMP-2.

[0375] In addition to the above analytes, other molecules useful for detecting the presence and/or amounts of analytes related to regulation of MMPs, metastasis and/or extracellular matrix function include receptors for TNF-alpha, IL-1 beta, IL-2, VEGF, tissue inhibitor of metalloproteinase-1 (TIMP-1), TIMP-2, TIMP-3, Pro-Cathepsin B, Cathepsin B, Cathepsin L, Cathepsin D, Plasmin, and α -2 macroglobulin. Cathepsins are cysteine proteases that can be involved in metastatic processes through their effects on extracellular matrix turnover. The MMPs are zinc-containing proteinases that can have collagenase effects (e.g., MMP-1; MMP-13), gelatinase effects (e.g., MMP-2; MMP-9). TIMP-1 can inhibit metalloproteinases. The presence of zinc in certain of the above proteinases can permit their easy detection by Raman spectroscopy.

EXAMPLE 30

Intracellular Regulation Biochip™

[0376] In other embodiments, an Intracellular Regulation Biochip™ can be used for measuring secondary messengers

such as cAMP and calmodulin and targets involved in calcium regulation. Calmodulin antibodies are commercially available, as are cAMP-binding proteins and enzymes that use cAMP as a substrate or cofactor.

EXAMPLE 31

Cellular Oxidative Stress Biochip™

[0377] In still further embodiments, a Cellular Oxidative Stress Biochip™ can be used for measuring analytes relevant to a cell's oxidative state. Heat shock proteins (Hsp), including Hsp27, Hsp70, Hsp90, and Hsp90 can be induced by radiation, general oxidative stress, and can protect cells from stress. Malondialdehyde is a general marker of oxidation. Nitrosotyrosine is associated with excessive nitric oxide (NO), and can be easily detected by Raman spectroscopy due to the presence of tyrosine-NO. Nitric oxide synthetase is an enzyme that can produce NO. Superoxide dismutase 1 (SOD-1) can react with superoxide to form hydrogen peroxide. SODs can be easily detected by Raman spectroscopy due to the presence of copper and/or zinc. Glutathione peroxidase (GSH-Px) is a selenium-containing enzyme that can degrade hydrogen and lipid peroxides to water or alcohol-lipids. GSH-Px can be easily detected using Raman spectroscopy due to the presence of selenium. Glutathione reductase (GR) is a FADH-dependent enzyme that can reduce oxidized glutathione, (GSSG) to glutathione (GSH). GR can be easily detected using Raman spectroscopy due to the presence of the flavin-containing co-factor of FADH.

[0378] In addition, certain other embodiments of the invention include inflammatory markers. Thus, cyclooxygenase-1 (COX-1), cyclooxygenase-2 (COX-2), thromboxanes, prostaglandin H synthetase, and isoprostane iPf2 α -VI can be easily detected using Raman spectroscopy due to the presence of aliphatic carbon atoms. Heme oxygenase and catalase can also be easily detected using Raman spectroscopy, due to the presence of heme (iron-containing molecule)s.

EXAMPLE 32

Inflammatory Mediator Biochip™

[0379] In other embodiments, an Inflammatory Mediator Biochip™ can be advantageously used to characterize a cell, tissue, organ or organism's inflammatory mediator status. Thus, interleukins (IL) including IL-1, IL-2, IL-3, IL-4, IL-5, IL-6 can be analyzed using antibodies directed at the ILs. Interleukins are cytokines indicative of immune system activation. Additionally, tissue necrosis factor (TNF), including TNF- α , or "chachetin" is a cytokine produced by macrophages that has catabolic effects, as well as being an important indicator of insulin resistance. C-reactive protein is associated with acute phase immune responses. Ceruloplasmin is an acute phase immune indicator that contains copper, making it easily detected using Raman spectroscopy. Macrophage inflammatory peptide (MIP) is a marker in the serum for inflammation. Prostaglandins (PGs) are fatty acid derivatives indicating inflammation. Leukotrienes (LTs) and thromboxanes (TXs) are also fatty acid derived inflammatory mediators. PGs, LTs and TXs can be synthesized from cellular membranes, and thus, can indicate cell membrane damage. PGs, LTs and TXs are easily detected using Raman

spectroscopy, due to the presence of aliphatic carbon atoms. Cortisol is an example of a glucocorticoid hormone that can exert immunosuppressive effects, and is associated with activation of the hypothalamic-pituitary-adrenal axis.

EXAMPLE 33

Insulin Resistance Biochip™

[0380] In other embodiments, an Insulin Resistance Biochip™ can be advantageously be used to characterize an organism's glucose metabolism. Analytes that may be desirable include white blood cells, which can be associated with insulin resistance (IR) and infection, and TNF- α . Additionally, fasting or non-fasting serum or blood levels of insulin, proinsulin, Apolipoprotein A (Apo-A), ferritin, very low density lipoproteins (VLDL), free fatty acids (FFA), and high-density lipoproteins (HDL) can reflect glucose status. Insulin and proinsulin can be easily detected using Raman spectroscopy, due to the presence of interchain disulfides and/or intrachain disulfides. Apo-A, HDL and VLDL can be easily detected using Raman spectroscopy due to the presence of aliphatic carbon atoms in triglycerides. Free fatty acids can be easily detected using Raman spectroscopy due to presence of aliphatic carbon atoms.

[0381] Measurements of insulin resistance are important in that they can predict a variety of age-related diseases such as hypertension, coronary heart disease, stroke, cancer, and type 2 diabetes. (Facchini et al., *Insulin resistance as a predictor of age-related disease, J Clin Endocrinol Metab.* 86(8):3574-3578 (2001). Recent findings by the Center for Disease Control show that approximately 47 million Americans are affected by insulin resistance (*JAMA*, 287 (3):356-359 (Jan. 16, 2002).

[0382] Measurements of insulin resistance are usually based upon indications such as elevated fasting levels of insulin or preferably using the "gold standard" method which is a physiological clamp technique (Elahi D, *In praise of the hyperglycemic clamp: A method for assessment of beta-cell sensitivity and insulin resistance.* *Diabetes Care* 19(3):278-86, (1996).

[0383] For general medical practice and research purposes it would be desirable to identify and measure surrogate markers for IR. For example, IR is associated with white blood cell count (WBC) and with levels of triglycerides, glucose and HDL cholesterol.

[0384] In human subjects, increased levels of WBC correlate with IR. (Facchini et al. WBC counts ranged from 5-10 $\times 10^9$ /liter positively correlated with insulin response levels after an oral glucose load. These insulin levels ranged from approximately 500-4000 pmol/liter/r =0.50, p-value<0.001). A significant relationship was found between WBC count and serum triglycerides (correlation coefficient, r=0.37, p<0.005) and glucose r=0.48, p-value<0.001). A significant inverse relationship was found between HDL cholesterol levels and WBC count r=-0.38, p<0.005). An elevated WBC is well known to be associated with infection or inflammation. Activated white blood cells produce TNF- α , a peptide which highly associated with IR. Thus, measurements of WBC, TNF- α , and/or other surrogate markers can be useful diagnosing and/or monitoring treatment of insulin resistance. Thus, in the absence of acute infection, inflammation, or of leukemias, a WBC above

about 6×10^9 /liter. Alternatively, in other embodiments a WBC above about 7×10^9 /liter is diagnostic of insulin resistance.

[0385] In a cross sectional study of 70 subjects (Paolisso et al., *Advancing age and insulin resistance: role of plasma tumor necrosis factor- α* *Am J Physiol* 275(2 Pt 1):E294-9 Vol. 275 (1998), plasma TNF- α concentration correlated with whole body glucose disposal (WBGD; $r = -0.38$, $P < 0.01$) and advancing age $r = 0.64$, $P < 0.001$). The serum levels of TNF- α in this study range from approximately 1 to 120 pg/ml. Thus, in the absence of acute infection, TNF- α concentrations above about 30 pg/ml are herein considered to be diagnostic of insulin resistance. Alternatively, TNF- α concentrations above about 35 pg/ml, and in other embodiments, above about 40 pg/ml can be considered to be diagnostic of insulin resistance.

[0386] The same authors reported in a related longitudinal study (see above reference), using 50 of the subjects from the two highest tertiles selected from the previous study, that plasma TNF- α concentration predicted a decline in WBGD independent of age, sex, body fat, waist to hip ratio (WHR) [relative risk (RR)=2.0; 95% confidence intervals (CI)=1.2-2.4]. Thus measurements of TNF- α can be a useful indicator of insulin resistance.

[0387] Insulin resistance appears to vary with body stores of iron (Hua et al., *Low iron status and enhanced insulin sensitivity in lacto-ovo vegetarians* *Br J Nutr.* 86(4):515-519 (2001)). In this study, lacto-ovo vegetarians were found to be more insulin sensitive than meat-eaters, with a steady-state plasma glucose (mmol/l) of 4.1 (95% confidence intervals (CI) of 3.5, 5.0) v. 6.9 (95% CI 5.2, 7.5; respectively). Lacto-ovo vegetarians had lower body iron (Fe) stores, as indicated by a serum ferritin concentration ($\mu\text{g/l}$) of 35 (95% CI 21, 49) compared with 72 (95% CI 45, 100) for meat-eaters. Thus, if ferritin concentration, is above 100 $\mu\text{g/liter}$ is diagnostic of insulin resistance.

[0388] Fasting insulin levels above the well-known threshold are diagnostic of insulin resistance (McAuley et al., *Diagnosing Insulin Resistance in the General Population*, *Diabetes Care*, 24(3):460-464 (2001), incorporated herein fully by reference.

[0389] Decreased HDL also can also be diagnostic of insulin resistance. Thus, even sub-threshold elevations of WBC, TNF- α , fasting insulin and/or ferritin, in combination with decreased HDL is considered herein to be diagnostic of insulin resistance.

[0390] Therefore, in certain embodiments of this invention, Insulin Resistance Biochip™ can include receptors for any of the above surrogate markers. In other embodiments, biochips are provided that can include the surrogate markers along with one or more “direct” markers of insulin resistance, for example, insulin, pro-insulin, glucose or FFAs.

[0391] For the above analytes, receptors can include specific antibodies directed toward each analyte. For some analytes, for example, FFAs, biological receptors can be useful. FFA binding proteins (FABPs) can be obtained from serum. Alternatively, because FFAs can be adsorbed onto albumin, albumin can be used as a FFA receptor. Glucose receptors can include biological glucose receptors, by way of example, Glut-1, Glut-4 and the like. Many biological glucose receptors or membrane transporters are known.

EXAMPLE 34

Apoptosis Biochip™

[0392] In other embodiments, an Apoptosis Biochip™ can be advantageously used to characterize cell death, cell degeneration and/or cell repair. Cytochrome-C (Cyt-C) is a heme-containing protein that can be easily detected using Raman spectroscopy. Receptors for Cyt-C include commercially available antibodies (e.g., Calbiochem). Bak is a promoter of apoptosis, and an anti-Bak antibody is commercially available (Calbiochem). Bax is another promoter of apoptosis that is associated with release of mitochondrial Cyt-C, and anti-Bax antibodies are commercially available (Calbiochem). Bcl-x and Bcl-2 are apoptosis suppressors, and antibodies directed against each of these are commercially available (Calbiochem). Bcl-1 is an apoptosis promoter, and anti-Bcl-1 antibodies are available (CN Biosciences/Merck). Additionally, p-53 can be assayed using an anti-p-53 antibody. Caspases, including caspase-2 and caspase-3, etc. are serine proteases that can cleave specific cellular proteins and can lead to cell death. PARP is a zinc-containing binding protein associated with cell repair. Receptors for numerous PARPs and sub-family members are commercially available (CN Biosciences/Merck). WAF-1 (p21) is an inhibitor of cyclin-dependent kinases, and is available commercially.

[0393] Because several of the above-identified markers reflect increased apoptosis whereas other markers reflect decreased apoptosis, ratios of, for example, Bcl-x or Bcl-2 to Bcl-1 can be useful to characterize overall trends in apoptosis.

INDUSTRIAL APPLICABILITY

[0394] Biochips of this invention enable the detection and quantification of a variety of molecules, cells, cellular components of physiological and/or pathophysiological significance. The analytes measured include those associated with cellular energetics, cellular oxidative state, cellular metabolism, glucose metabolism, inflammatory state, apoptosis and metastatic disease. Biochips of this invention therefore can find utility in the fields of medicine, medical diagnostics, biomedical research and the pharmaceutical industry.

We claim:

1. A device for measuring a set of biological analytes, comprising:

a substrate;

a plurality of enhancing particle structures on said substrate; and

a set of receptor types, each receptor type being specific for one member of said set of biological analytes, each of said receptor types being spatially separated from other receptor types on said substrate.

2. The device of claim 1, further comprising a passivation agent associated with said substrate or said plurality of enhancing structures.

3. The device of claim 1, wherein each of said receptor types is specific for an analyte selected from the group consisting of cAMP, serotonin, monoamine oxidase I, monoamine oxidase II, beta-amyloid peptide, Tau protein, PrP^{Sc}, ATP, ADP, AMP, enzymes involved in energy metabolism, calmodulin, calmodulin binding protein, heat-

shock proteins, superoxide dismutase, glutathione peroxidase, reduced and oxidized glutathione, nitrotyrosine, FADH, NADH, pyruvate, acetyl Co-A, GTP, NADPH, NADPH oxido-reductase, catalase, cytochrome-A, cytochrome-B, cytochrome-C, beta-hydroxybutyrate, acetylacetate, lactate, glycerol 3-phosphate, glucose 6-phosphate, creatine phosphate, 1,3-diphosphoglycerate, phosphoenolpyruvic acid, acetylphosphate, UTP, CTP, dATP, dGTP, dTTP and dCTP.

4. A device for measuring an analyte, comprising:

a substrate;

an enhancing particle structure; and

a receptor specific for a carcinophore.

5. The device of claim 4, wherein said carcinophore is a metalloproteinase.

6. The device of claim 4, wherein said carcinophore is selected from the group consisting of Pro MMP-1, MMP-1, Pro MMP-9, MMP-9, MT1-MMPT, Pro MMP-2, MMP-2, TNF-alpha, IL-1 beta, IL2, VEGF, TIMP-1, TIMP-2, TIMP-3, Pro-cathepsin, cathepsin B and plasmin.

7. The device of claim 2, wherein said set of receptor types includes at least two receptor types, each of said receptor types specific for an analyte selected from the group consisting of cytochrome-C, Bak, Bax, Bcl-x, Bcl-1, Bcl-2, p-53, caspase-2, caspase-3, PARP, and WAF-1.

8. The device of claim 2, wherein said set of receptor types includes at least two receptor types, each of said receptor types specific for an analyte selected from the group consisting of ATP, ADP, AMP, creatine, creatine-phosphate, lactic acid, acetyl-CoA, NADH, NAD⁺, NADPH, NADP⁺, GTP, total mitochondria, B-OHb and AcA.

9. The device of claim 2, wherein said set of receptor types includes at least two receptor types, each of said receptor types specific for an analyte selected from the group consisting of Hsp27, Hsp70, Hsp0, Hsp90, malondialdehyde, nitrosotyrosine, nitric oxide synthetase, superoxide dismutase, glutathione peroxidase, glutathione reductase, cyclooxygenase 1, cyclooxygenase 2, a thromboxane, a prostaglandin, prostaglandin H synthetase, isoprostane ipF2 α -VI, heme oxygenase and catalase.

10. The device of claim 2, wherein said set of receptor types includes at least two receptor types, each of said receptor types specific for an analyte selected from the group consisting of IL-1, IL-2, IL-3, IL-4, IL-5, IL-6, TNF- α , C-reactive protein, ceruloplasmin, MTP, a prostaglandin, a leukotriene and a glucocorticoid.

11. The device of claim 2, wherein said set of receptor types includes at least two receptor types, each of said receptor types specific for an analyte selected from the group consisting of white blood cells, TNF- α , insulin, proinsulin, Apo-A, ferritin, a VLDL, a FFA, glucose, and an HDL.

12. The device of claim 2, wherein said set of receptor types includes at least two receptor types, each of said receptor types specific for an analyte selected from the group consisting of cathepsin-B, cathepsin-L, cathepsin-D, MMP-1, MMP-2, MMP-9, MMP-13, α 2-macroglobulin, and TIMP-1.

13. The device of claim 1, wherein said set of receptor types includes at least two receptor types, each of said receptor types specific for an analyte selected from the group consisting of cytochrome-C, Bak, Bax, Bcl-x, Bcl-1, Bcl-2, p-53, caspase-2, caspase-3, PARP, and WAF-1.

14. The device of claim 1, wherein said set of receptor types includes at least two receptor types, each of said receptor types specific for an analyte selected from the group consisting of ATP, ADP, AMP, creatine, creatine-phosphate, lactic acid, acetyl-CoA, NADH, NAD⁺, NADPH, NADP⁺, GTP, total mitochondria, B-OHb and AcA.

15. The device of claim 1, wherein said set of receptor types includes at least two receptor types, each of said receptor types specific for an analyte selected from the group consisting of Hsp27, Hsp70, Hsp0, Hsp90, malondialdehyde, nitrosotyrosine, nitric oxide synthetase, superoxide dismutase, glutathione peroxidase, glutathione reductase, cyclooxygenase 1, cyclooxygenase 2, a thromboxane, a prostaglandin, prostaglandin H synthetase, isoprostane ipF2 α -VI, heme oxygenase and catalase.

16. The device of claim 1, wherein said set of receptor types includes at least two receptor types, each of said receptor types specific for an analyte selected from the group consisting of IL-1, IL-2, IL-3, IL-4, IL-5, IL-6, TNF- α , C-reactive protein, ceruloplasmin, MTP, a prostaglandin, a leukotriene and a glucocorticoid.

17. The device of claim 1, wherein said set of receptor types includes at least two receptor types, each of said receptor types specific for an analyte selected from the group consisting of white blood cells, TNF- α , insulin, proinsulin, Apo-A, ferritin, a VLDL, a FFA, glucose, and an HDL.

18. The device of claim 1, wherein said set of receptor types includes at least two receptor types, each of said receptor types specific for an analyte selected from the group consisting of cathepsin-B, cathepsin-L, cathepsin-D, MMP-1, MMP-2, MMP-9, MMP-13, α 2-macroglobulin, and TIMP-1.

19. The device of claim 1, wherein said set of receptor types includes at least two receptor types, each of said receptor types specific for an analyte selected from the group consisting of cytochrome-A, cytochrome-B, cytochrome-C, Bak, Bax, Bcl-x, Bcl-1, Bcl-2, p-53, caspase-2, caspase-3, PARP, and WAF-1, ATP, ADP, AMP, creatine, creatine-phosphate, lactic acid, acetyl-CoA, NADH, NAD⁺, NADPH, NADP⁺, GTP, total mitochondria, B-OHb and AcA, Hsp27, Hsp70, Hsp0, Hsp90, malondialdehyde, nitrosotyrosine, nitric oxide synthetase, superoxide dismutase, glutathione peroxidase, glutathione reductase, cyclooxygenase 1, cyclooxygenase 2, a thromboxane, a prostaglandin, prostaglandin H synthetase, isoprostane ipF2 α -VI, heme oxygenase and catalase, IL-1, IL-2, IL-3, IL-4, IL-5, IL-6, TNF- α , C-reactive protein, ceruloplasmin, MTP, a prostaglandin, a leukotriene and a glucocorticoid, white blood cells, TNF- α , insulin, proinsulin, Apo-A, ferritin, a VLDL, a FFA, glucose, and an HDL, cathepsin-B, cathepsin-L, cathepsin-D, MMP-1, MMP-2, MMP-9, MMP-13, α 2-macroglobulin, and TIMP-1, cAMP, serotonin, monoamine oxidase I, monoamine oxidase II, beta-amyloid peptide, Tau protein, PrP^{Sc}, calmodulin, calmodulin binding protein, FADH, pyruvate, GTP, NADPH oxido-reductase, catalase, lactate, glycerol 3-phosphate, glucose 6-phosphate, 1,3diphosphoglycerate, phosphoenolpyruvic acid, acetylphosphate, UTP, CTP, dATP, dGTP, dTTP, dCTP, Pro MMP-1, Pro MMP-9, MT1-MMPT, Pro MMP-2, TNF-alpha, IL-1 beta, VEGF, TIMP-2, TIMP-3, Pro-cathepsin, cathepsin B and plasmin.

20. A device for measuring an analyte, comprising:

a substrate;

at least one enhancing particle structure on said substrate; and

at least one receptor type specific for an analyte selected from the group consisting of cytochrome-A, cytochrome-B, cytochrome-C, Bak, Bax, Bcl-x, Bcl-1, Bcl-2, p-53, caspase-2, caspase-3, PARP, and WAF-1, ATP, ADP, AMP, creatine, creatine-phosphate, lactic acid, acetyl-CoA, NADH, NAD⁺, NADPH, NADP⁺, GTP, total mitochondria, B-OHb and AcA, Hsp27, Hsp70, Hsp0, Hsp90, malondialdehyde, nitrosotyrosine, nitric oxide synthetase, superoxide dismutase, glutathione peroxidase, glutathione reductase, cyclooxygenase 1, cyclooxygenase 2, a thromboxane, a prostaglandin, prostaglandin H synthetase, isoprostane ipF2 α -VI, heme oxygenase and catalase, IL-1, IL-2, IL-3, IL-4, IL-5, IL-6, TNF- α , C-reactive protein, ceruloplasmin, MTP, a prostaglandin, a leukotriene and a glucocorticoid, white blood cells, TNF- α , insulin, proinsulin, Apo-A, ferritin, a VLDL, a FFA, glucose, and a HDL, cathepsin-B, cathepsin-L, cathepsin-D, MMP-1, MMP-2, MMP-9, MMP-13, α 2-macroglobulin, and TIMP-1, cAMP, serotonin, monoamine oxidase I, monoamine oxidase II, beta-amyloid peptide, Tau protein, PrP^{Sc}, calmodulin, calmodulin binding protein, FADH, pyruvate, GTP, NADPH oxido-reductase, catalase, lactate, glycerol 3-phosphate, glucose 6-phosphate, 1,3-diphosphoglycerate, phosphoenolpyruvic acid, acetylphosphate, UTP, CTP, dATP, dGTP, dTTP, dCTP, Pro MMP-1, Pro MMP-9, MT1-MMPT, Pro MMP-2, TNF-alpha, IL-1 beta, VEGF, TIMP-2, TIMP-3, Pro-cathepsin, cathepsin B and plasmin.

21. The device of claim 2, wherein said set of receptor types includes at least two receptor types, each of said receptor types specific for an analyte selected from the group consisting of cytochrome-A, cytochrome-B, cytochrome-C, Bak, Bax, Bcl-x, Bcl-1, Bcl-2, p-53, caspase-2, caspase-3, PARP, and WAF-1, ATP, ADP, AMP, creatine, creatine-phosphate, lactic acid, acetyl-CoA, NADH, NAD⁺, NADPH, NADP⁺, GTP, total mitochondria, B-OHb and AcA, Hsp27, Hsp70, Hsp0, Hsp90, malondialdehyde, nitrosotyrosine, nitric oxide synthetase, superoxide dismutase, glutathione peroxidase, glutathione reductase, cyclooxygenase 1, cyclooxygenase 2, a thromboxane, a prostaglandin, prostaglandin H synthetase, isoprostane ipF2 α -VI, heme oxygenase and catalase, IL-1, IL-2, IL-3, IL-4, IL-5, IL-6, TNF- α , C-reactive protein, ceruloplasmin, MTP, a prostaglandin, a leukotriene and a glucocorticoid, white blood cells, TNF- α , insulin, proinsulin, Apo-A, ferritin, a VLDL, a FFA, glucose, and a HDL, cathepsin-B, cathepsin-L, cathepsin-D, MMP-1, MMP-2, MMP-9, MMP-13, α 2-macroglobulin, and TIMP-1, cAMP, serotonin, monoamine oxidase I, monoamine oxidase II, beta-amyloid peptide, Tau protein, PrP^{Sc}, calmodulin, calmodulin binding protein, FADH, pyruvate, GTP, NADPH oxido-reductase, catalase, lactate, glycerol 3-phosphate, glucose 6-phosphate, 1,3-diphosphoglycerate, phosphoenolpyruvic acid, acetylphosphate, UTP, CTP, dATP, dGTP, dTTP, dCTP, Pro MMP-1, Pro MMP-9, MT1-MMPT, Pro MMP-2, TNF-alpha, IL-1 beta, VEGF, TIMP-2, TIMP-3, Pro-cathepsin, cathepsin B and plasmin.

22. The device of claim 1, wherein said set of receptor types includes at least two receptor types, each of said receptor types specific for an analyte selected from the group consisting of cytochrome-A, cytochrome-B, cytochrome-C, Bak, Bax, Bcl-x, Bcl-1, Bcl-2, p-53, caspase-2, caspase-3, PARP, and WAF-1, ATP, ADP, AMP, creatine, creatine-phosphate, lactic acid, acetyl-CoA, NADH, NAD⁺,

NADPH, NADP⁺, GTP, total mitochondria, B-OHb and AcA, Hsp27, Hsp70, Hsp0, Hsp90, malondialdehyde, nitrosotyrosine, nitric oxide synthetase, a superoxide dismutase, glutathione peroxidase, glutathione reductase, cyclooxygenase 1, cyclooxygenase 2, a thromboxane, a prostaglandin, prostaglandin H synthetase, isoprostane ipF2 α -VI, heme oxygenase and catalase, IL-1, IL-2, IL-3, IL-4, IL-5, IL-6, TNF- α , C-reactive protein, ceruloplasmin, MTP, a prostaglandin, a leukotriene, a glucocorticoid, white blood cells, TNF- α , insulin, proinsulin, Apo-A, ferritin, a VLDL, a FFA, glucose, an HDL, cathepsin-B, cathepsin-L, cathepsin-D, MMP-1, MMP-2, MMP-9, MMP-13, α 2-macroglobulin, TIMP-1, cAMP, serotonin, monoamine oxidase I, monoamine oxidase II, beta-amyloid peptide, Tau protein, PrP^{Sc}, calmodulin, calmodulin binding protein, FADH, pyruvate, GTP, NADPH oxido-reductase, catalase, lactate, glycerol 3-phosphate, glucose 6-phosphate, 1,3-diphosphoglycerate, phosphoenolpyruvic acid, acetylphosphate, UTP, CTP, dATP, dGTP, dTTP, dCTP, Pro MMP-1, Pro MMP-9, MT1-MMPT, Pro MMP-2, TNF-alpha, IL-1 beta, VEGF, TIMP-2, TIMP-3, Pro-cathepsin, cathepsin B and plasmin.

23. A method for analyzing a biological process, comprising:

(a) providing a substrate having:

a plurality of enhancing particle structures on said substrate; and

at least one receptor type associated with said enhancing particle structures, said receptor type being specific for a bioanalyte characteristic of said biological process;

(b) placing a biological sample containing said bioanalyte in contact with said receptors; and

(c) detecting and/or quantifying the presence of said bioanalyte.

24. The method of claim 23, further comprising, after step (b), washing unbound analyte from said substrate.

25. The method of claim 23, wherein said bioanalyte is selected from the group consisting of cytochrome-A, cytochrome-B, cytochrome-C, Bak, Bax, Bcl-x, Bcl-1, Bcl-2, p-53, caspase-2, caspase-3, PARP, and WAF-1, ATP, ADP, AMP, creatine, creatine-phosphate, lactic acid, acetyl-CoA, NADH, NAD⁺, NADPH, NADP⁺, GTP, total mitochondria, B-OHb and AcA, Hsp27, Hsp70, Hsp0, Hsp90, malondialdehyde, nitrosotyrosine, nitric oxide synthetase, superoxide dismutase, glutathione peroxidase, glutathione reductase, cyclooxygenase 1, cyclooxygenase 2, a thromboxane, a prostaglandin, prostaglandin H synthetase, isoprostane ipF2 α -VI, heme oxygenase and catalase, IL-1, IL-2, IL-3, IL-4, IL-5, IL-6, TNF- α , C-reactive protein, ceruloplasmin, MTP, a prostaglandin, a leukotriene and a glucocorticoid, white blood cells, TNF- α , insulin, proinsulin, Apo-A, ferritin, a VLDL, a FFA, glucose, and a HDL, cathepsin-B, cathepsin-L, cathepsin-D, MMP-1, MMP-2, MMP-9, MMP-13, α 2-macroglobulin, and TIMP-1, cAMP, serotonin, monoamine oxidase I, monoamine oxidase II, beta-amyloid peptide, Tau protein, PrP^{Sc}, calmodulin, calmodulin binding protein, FADH, pyruvate, GTP, NADPH oxido-reductase, catalase, lactate, glycerol 3-phosphate, glucose 6-phosphate, 1,3-diphosphoglycerate, phosphoenolpyruvic acid, acetylphosphate, UTP, CTP, dATP, dGTP, dTTP, dCTP, Pro MMP-1, Pro MMP-9, MT1-MMPT, Pro MMP-2, TNF-alpha, IL-1 beta, VEGF, TIMP-2, TIMP-3, Pro-cathepsin, cathepsin B and plasmin.

26. The method of claim 23, wherein said substrate has at least one additional receptor type specific for a different bioanalyte of said set of bioanalytes.

27. The method of claim 26, wherein said additional bioanalyte is selected from the group consisting of cytochrome-A, cytochrome-B, cytochrome-C, Bak, Bax, Bcl-x, Bcl-1, Bcl-2, p-53, caspase-2, caspase-3, PARP, and WAF-1, ATP, ADP, AMP, creatine, creatine-phosphate, lactic acid, acetyl-CoA, NADH, NAD⁺, NADPH, NADP⁺, GTP, total mitochondria, B-OHb and AcA, Hsp27, Hsp70, Hsp90, Hsp90, malondialdehyde, nitrosotyrosine, nitric oxide synthetase, superoxide dismutase, glutathione peroxidase, glutathione reductase, cyclooxygenase 1, cyclooxygenase 2, a thromboxane, a prostaglandin, prostaglandin H synthetase, isoprostane ipF2 α -VI, heme oxygenase and catalase, IL-1, IL-2, IL-3, IL-4, IL-5, IL-6, TNF- α , C-reactive protein, ceruloplasmin, MTP, a prostaglandin, a leukotriene and a glucocorticoid, white blood cells, TNF- α , insulin, proinsulin, Apo-A, ferritin, a VLDL, a FFA, glucose, and a HDL, cathepsin-B, cathepsin-L, cathepsin-D, MMP-1, MMP-2, MMP-9, MMP-13, α 2-macroglobulin, and TIMP-1, cAMP, serotonin, monoamine oxidase I, monoamine oxidase II, beta-amyloid peptide, Tau protein, PrP^{Sc}, calmodulin, calmodulin binding protein, FADH, pyruvate, GTP, NADPH oxido-reductase, catalase, lactate, glycerol 3-phosphate, glucose 6-phosphate, 1,3-diphosphoglycerate, phosphoenolpyruvic acid, acetylphosphate, UTP, CTP, dATP, dGTP, dTTP, dCTP, Pro MMP-1, Pro MMP-9, MT1-MMPT, Pro MMP-2, TNF-alpha, IL-1 beta, VEGF, TIMP-2, TIMP-3, Pro-cathepsin, cathepsin B and plasmin.

28. A method for manufacturing a biochip, comprising:

- (a) providing a substrate;
- (b) attaching a plurality of enhancing particle structures to said substrate; and
- (c) attaching at least one receptor to said biochip, said receptor associated with at least one of said particle structures, said receptor adapted to associate with a bioanalyte characteristic of a biological process.

29. The method of claim 28, further comprising attaching at least one additional receptor to said biochip, said at least one additional receptor adapted to associated with another bioanalyte characteristic of said biological process.

30. The method of claim 29, further comprising passivating one or more of said substrate and said plurality of enhancing particle structures.

31. The device of claim 1, wherein said enhancing particle structures are fractal structures.

32. The device of claim 2, wherein said enhancing particle structures are fractal structures.

33. The device of claim 4, wherein said enhancing particle structures are fractal structures.

34. The device of claim 20, wherein said enhancing particle structures are fractal structures.

35. The method of claim 23, wherein said enhancing particle structures are fractal structures.

36. The method of claim 28, wherein said enhancing particle structures are fractal structures.

37. A device for measuring a set of biological analytes, comprising:

a substrate;

means for enhancing a Raman signal of one of said biological analytes on said substrate; and

a set of receptor types, each receptor type being specific for one member of said set of biological analytes, each of said receptor types being spatially separated from other receptor types on said substrate.

38. The device of claim 37, further comprising a passivating agent associated with said substrate or said plurality of enhancing structures.

39. A method for analyzing a biological process, comprising:

(a) providing a substrate having:

means for enhancing a Raman signal of a bioanalyte characteristic of said biological process; and

at least one receptor type associated with said means for enhancing a Raman signal, said receptor type being specific for said bioanalyte;

(b) placing a biological sample containing said bioanalyte in contact with said receptors; and

(c) detecting and/or quantifying the presence of said bioanalyte.

40. The method of claim 39, further comprising providing said substrate with at least one additional receptor type associated with said means for enhancing a Raman signal, said receptor type being specific for another bioanalyte characteristic of said biological process.

* * * * *

专利名称(译)	用于表征生物过程的生物芯片		
公开(公告)号	US20040023293A1	公开(公告)日	2004-02-05
申请号	US10/294385	申请日	2002-11-14
[标]申请(专利权)人(译)	克赖默DAVID我 NUFERT托马斯达 GINZBURG LEV YEVIN OLEG一个		
申请(专利权)人(译)	克赖默DAVID I. NUFERT THOMAS H. GINZBURG LEV YEVIN OLEG A.		
当前申请(专利权)人(译)	克赖默DAVID I. NUFERT THOMAS H. GINZBURG LEV YEVIN OLEG A.		
[标]发明人	KREIMER DAVID I NUFERT THOMAS H GINZBURG LEV YEVIN OLEG A		
发明人	KREIMER, DAVID I. NUFERT, THOMAS H. GINZBURG, LEV YEVIN, OLEG A.		
IPC分类号	B01J13/00 B82B1/00 C12Q1/68 F24J2/48 F24S10/95 F28D15/02 G01N21/35 G01N21/55 G01N21/64 G01N21/65 G01N33/543 G01N33/553 G01N33/566 G01N33/53 G01N33/574 C12M1/34		
CPC分类号	B01J13/0008 G01N21/05 B82B1/00 B82Y30/00 C12Q1/6837 F24J2/32 F24J2/48 F28D15/02 G01N21 /35 G01N21/64 G01N21/658 G01N33/54313 G01N33/54366 G01N33/54373 G01N33/553 G01N33/566 Y02E10/44 B01J13/0043 C12Q2565/632 C12Q2527/125 F24S70/10 Y02E10/40		
优先权	60/156195 1999-09-27 US 60/336445 2001-11-14 US		
外部链接	Espacenet USPTO		

摘要(译)

本发明包括用于分析各种分子，细胞组分和细胞的生物芯片。本发明的实施方案包括用于平行和/或几乎平行处理生物分析物的装置和方法。生物芯片可包括底物，拉曼信号增强结构，以及对待测定的分析物具有选择性和/或特异性的受体。可以使用拉曼读数器读取生物芯片，并且可以为感兴趣的生理和/或病理生理条件提供快速，灵敏，直接的测定。

