

(19) World Intellectual Property  
Organization  
International Bureau



(43) International Publication Date  
18 August 2005 (18.08.2005)

PCT

(10) International Publication Number  
**WO 2005/076013 A2**

- (51) International Patent Classification<sup>7</sup>: **G01N 33/76**, C07K 16/26, G01N 33/569, C07K 14/59, 16/00
- (21) International Application Number: PCT/EP2005/001160
- (22) International Filing Date: 4 February 2005 (04.02.2005)
- (25) Filing Language: English
- (26) Publication Language: English
- (30) Priority Data: 04 290 290.8 4 February 2004 (04.02.2004) EP
- (71) Applicants (for all designated States except US): **CENTRE NATIONAL DE LA RECHERCHE SCIENTIFIQUE** [FR/FR]; 3, rue Michel-Ange, F-75794 Paris Cedex 16 (FR). **UNIVERSITE DE PROVENCE AIX-MARSEILLE 1** [FR/FR]; 3, Place Victor Hugo, F-13003 Marseille (FR).
- (72) Inventors; and
- (75) Inventors/Applicants (for US only): **RONIN, Catherine** [FR/FR]; 23, rue Lamartine, F-13960 Sausset-Les-Pins (FR). **DONADIO, Sandrine** [FR/FR]; 12, Boulevard Rougier, F-13004 Marseille (FR).
- (74) Agents: **GROSSET-FOURNIER, Chantal** et al.; Grosset-Fournier & Demachy SARL, 54, rue Saint-Lazare, F-75009 Paris (FR).
- (81) Designated States (unless otherwise indicated, for every kind of national protection available): AE, AG, AL, AM, AT, AU, AZ, BA, BB, BG, BR, BW, BY, BZ, CA, CH, CN, CO, CR, CU, CZ, DE, DK, DM, DZ, EC, EE, EG, ES, FI, GB, GD, GE, GH, GM, HR, HU, ID, IL, IN, IS, JP, KE, KG, KP, KR, KZ, LC, LK, LR, LS, LT, LU, LV, MA, MD, MG, MK, MN, MW, MX, MZ, NA, NI, NO, NZ, OM, PG, PH, PL, PT, RO, RU, SC, SD, SE, SG, SK, SL, SY, TJ, TM, TN, TR, TT, TZ, UA, UG, US, UZ, VC, VN, YU, ZA, ZM, ZW.
- (84) Designated States (unless otherwise indicated, for every kind of regional protection available): ARIPO (BW, GH, GM, KE, LS, MW, MZ, NA, SD, SL, SZ, TZ, UG, ZM, ZW), Eurasian (AM, AZ, BY, KG, KZ, MD, RU, TJ, TM), European (AT, BE, BG, CH, CY, CZ, DE, DK, EE, ES, FI, FR, GB, GR, HU, IE, IS, IT, LT, LU, MC, NL, PL, PT, RO, SE, SI, SK, TR), OAPI (BF, BJ, CF, CG, CI, CM, GA, GN, GQ, GW, ML, MR, NE, SN, TD, TG).
- Published:**  
— without international search report and to be republished upon receipt of that report
- For two-letter codes and other abbreviations, refer to the "Guidance Notes on Codes and Abbreviations" appearing at the beginning of each regular issue of the PCT Gazette.*

(54) Title: PROCESS FOR SCREENING GLYCOFORM-SPECIFIC ANTIBODIES

(57) Abstract: The present invention relates to the use of the assessment of the binding between - antibodies elicited against a first glycoprotein, and - at least one glycoform of a second glycoprotein, said second glycoprotein being itself a glycoform of the first protein, wherein said glycoform of the second glycoprotein is selected from a group of glycoforms of the second glycoprotein, each glycoform of said group corresponding to a determined glycosylation state defined by a determined sialylation state, and/or a determined branching state, and/or a determined fucosylation state, provided that said glycosylation state is not uniquely defined by a substantially unsialylated state, for the screening of glycoform specific antibodies directed against a given glycoform of the second glycoprotein.

WO 2005/076013 A2

## PROCESS FOR SCREENING GLYCOFORM-SPECIFIC ANTIBODIES

---

The present invention relates to a process for screening glycoform-specific antibodies. The present invention also relates to a process for optimizing the recognition of specific glycoforms of a given glycoprotein.

There is currently a growing demand for measurement systems in which antibodies discriminate glycoproteins having a particular glycosylation pattern (*i.e.* discriminate specific glycoforms of a given glycoprotein). Such antibodies are particularly helpful for immunological assays intended for detecting and measuring the concentration of particular glycoforms of a given glycoprotein in body tissues and/or fluids.

For instance, the concentration, glycosylation and/or tissular source of glycoprotein hormones, such as TSH, LH or FSH, may be indicative of certain pathologies (Spencer, C.A. *et al.*, 1995; Spencer, C.A., and Demers, L.M., 2003).

However, several obstacles preclude the obtaining of such antibodies, the most important of which concerns the glycoprotein to be used to screen and/or to elicit the production of antibodies.

It is difficult to obtain glycoproteins with a desired glycosylation pattern, especially with a human-type glycosylation pattern, reliably and in large amounts. Thus, human or animal sources of glycoproteins, provide for very scarce amounts of protein. Moreover, the glycosylation pattern of the glycoproteins originating from animals is relatively different from that of human origin.

Recombinant glycoproteins are not an interesting alternative, in that the cell lines used for producing recombinant glycoproteins are mostly of animal origin. Therefore, these cell lines lead to the obtaining of a glycosylation pattern which markedly differ from the human-type glycosylation pattern. Besides, human cell lines can not produce all the various tissue-specific glycosylated glycoproteins.

Accordingly, research is currently being conducted to genetically design new cellular lines so as to produce glycoproteins carrying particular human type glycosylation patterns. Yet these lines are still not suited for protein production in large quantities and the cell line system is not sufficiently versatile to reproduce the whole array of human glycosylation types.

In another instance, the immunoreactivity of desialylated recombinant TSH produced in CHO cells was studied (Zerfaoui, M., and Ronin, C., 1996). However, the interest of using this single modification to screen glycoform-specific antibodies is dismal because most natural glycoproteins, especially those circulating in blood, are sialylated to a certain extent.

Besides, current TSH immunometric assays have been long established to represent the most sensitive and reliable approach for thyroid function testing. However, several comparative studies revealed significant inter- and intra-immunoprocures variations in TSH measurements, possibly resulting in mis- or undiagnosed patients and consequently misfit treatments. When recombinant TSH (recTSH) was first produced in CHO cells (Price, A., et al., 2001), this compound was felt to be a putative new candidate to replace the routinely used 2<sup>nd</sup> International Reference Preparation (IRP) of pituitary-extracted TSH. In 1999, the World Health Organization ordered a worldwide survey to validate the recombinant compound as a new Reference Material. Measurements of a recTSH preparation (94/674) were performed in 38 different immunoprocures by means of different formats i.e. RIA, IRMA, ELISA, IFMA, and/or ICLMA and standardized against the 2<sup>nd</sup> IRP pitTSH (80/558). The study revealed a significant variability from 5.51 mIU (3.95-7.67 mIU) per ampoule by RIA to 7.15 mIU (6.7-7.63 mIU) per ampoule by IFMA (Rafferty, B., et al., 1999). The potential use of this compound as new calibrant in TSH measurements was not documented further.

Thus, the present invention aims at:

- providing a new process for screening glycoform-specific antibodies;
- using the screened antibodies for the detection of a given glycoprotein;
- providing a process for isolating specific glycoforms of a given glycoprotein, said glycoforms being used:

- to screen glycoform-specific epitopes,
- to replace said glycoprotein to calibrate glycoform-specific immunoassays, or
- to elicit glycoform-specific antibodies.

The present invention relates to the use of the assessment of the binding between

- antibodies elicited against a first glycoprotein, and
- at least one glycoform of a second glycoprotein, said second glycoprotein being itself a glycoform of the first protein,

wherein said glycoform of the second glycoprotein is selected from a group of glycoforms of the second glycoprotein, each glycoform of said group corresponding to a determined glycosylation state defined by a determined sialylation state, and/or a determined branching state, and/or a determined fucosylation state, provided that said glycosylation state is not uniquely defined by a substantially unsialylated state,

for the screening of glycoform specific antibodies directed against a given glycoform of the second glycoprotein.

Most glycoproteins can be found under several forms which vary from each other by their respective glycan content, their respective protein sequence being essentially similar, *i.e.* the amino acid sequence similarity of each glycoprotein as compared to each other being greater than 90%, preferably greater than 95%, provided that both glycoproteins display the same biological properties; those forms are called glycoforms of a given glycoprotein.

The expression “antibodies elicited against a first glycoprotein” means that said antibodies are obtained after immunization of an animal by said first glycoprotein.

Advantageously those antibodies are monoclonal antibodies.

The glycosylation state of a given glycoprotein corresponds to the number of glycan chains carried by said glycoprotein and to the respective structures of those chains.

As a general rule a given glycoform can be characterized by a determined glycosylation state. However, it is worth noting that due to the remarkable diversity of the various protein glycosylation processes in cells, a given glycoform does not correspond to a unique glycosylation pattern but to a set of several closely related glycosylation patterns which can be accounted for by their average glycan structure. This average glycan structure will be herein understood to correspond to said glycosylation state.

The sialylation state corresponds to the number of sialyl groups which are carried by a given glycoprotein. In human glycoproteins, sialic acid most often corresponds to N-acetylneuraminic acid (NeuAc).

20

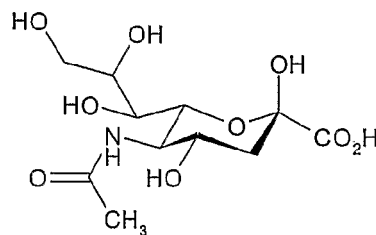

N-acetylneuraminic acid (NeuAc)

The expression “substantially unsialylated state” refers to a glycosylation pattern essentially lacking sialyl groups.

A glycosylation state is said to be “not uniquely defined by a substantially unsialylated state” if it is either not unsialylated or if its unsialylation is associated with other modification of the glycosylation state.

A glycoform, the glycosylation state of which is uniquely defined by a substantially unsialylated state, is of no relevance in the frame of the present invention since this feature is not a natural glycosylation feature, in particular in human circulation.

The fucosylation state corresponds to the number of fucosyl group which are carried  
5 by a given glycoprotein. In human glycoproteins, fucose corresponds to L-deoxygalactose.

The branching state corresponds to the number of  $\beta$  1,2/4/6 linked N-acetylglucosamine residues established with either of the branched mannose residue of the invariant pentasaccharide of N-linked glycans.

By way of illustration the structure of a typical N-linked glycan chain is represented in  
10 Figure 1A.

The glycan chain composition, especially the estimation of NeuAc, of fucose and of the degree of branching, can be assessed by acid hydrolysis of the glycoprotein, followed by derivatization and gas chromatography (Methods on Glycoconjugates: a laboratory manual. Ed: André Verbert, 1995). These data indicate the average composition per glycan chain (*i.e.*  
15 for 3 mannose residues).

A detailed glycan structure is obtained after releasing the glycan chains by endoglycosidase treatment and isolating each glycan chain by HPLC, following or not chemical derivatization by a fluorophore group. The molecular size of each species/peak is then resolved by mass spectrometry and its carbohydrate sequence is assessed by glycosidase  
20 sequential removal and further analysis of the shift in molecular weight using the same technique.

The present invention also relates to a process for screening glycoform specific antibodies among antibodies elicited against a first glycoprotein, comprising a step of determination of the binding between

25 - antibodies elicited against a first glycoprotein, and  
- at least one glycoform of a second glycoprotein, said second glycoprotein being itself a glycoform of the first protein,

wherein said glycoform of the second glycoprotein is selected from a group of glycoforms of the second glycoprotein, each glycoform of said group corresponding to a determined  
30 glycosylation state defined by a determined sialylation state, and/or a determined branching state, and/or a determined fucosylation state, provided that said glycosylation state is not uniquely defined by a substantially unsialylated state  
to recover antibodies liable to bind to at least one given glycoform of the second glycoprotein.

According to a particular embodiment, the glycosylation state of the glycoform of the second glycoprotein presents at least one of the following criteria:

- it is essentially more sialylated than said second glycoprotein, or
- it is essentially less sialylated than said second glycoprotein, or
- 5 - it is essentially more branched than said second glycoprotein, or
- it is essentially less branched than said second glycoprotein, or
- it is essentially more fucosylated than said second glycoprotein, or
- it is essentially less fucosylated than said second glycoprotein.

The expression "more sialylated" means that the glycan chains of said glycoform  
10 contain on average more sialyl groups than the glycan chains of the second glycoprotein do.

The expression "less sialylated" means that the glycan chains of said glycoform contain on average less sialyl groups than the glycan chains of the second glycoprotein do.

The expression "more branched" means that the glycan chains of said glycoform are on average more branched than the glycan chains of the second glycoprotein are.

15 The expression "less fucosylated" means that the glycan chains of said glycoform are on average less branched than the glycan chains of the second glycoprotein are.

The expression "more fucosylated" means that the glycan chains of said glycoform contain on average more fucosyl groups than the glycan chains of the second glycoprotein do.

20 The expression "less fucosylated" means that the glycan chains of said glycoform contain on average less fucosyl groups than the glycan chains of the second glycoprotein do.

These glycosylation states can be determined following the above described procedure.

Glycan heterogeneity is known to affect pharmacokinetics of glycoproteins, especially those circulating in blood depending on their sialic acid content. Glycosylation is often controlling biological properties of glycoproteins, such as receptor activation,  
25 pharmacokinetics of glycoprotein hormones (TSH, LH, FSH and hCG) and also physicochemical/structural properties, such as solubility, isoelectric point, thermal stability and resistance to proteolytic degradation. Except for sialic acid, these modifications cannot be attributed to a single monosaccharide, but often results from a steric contribution of the whole glycan chain.

30 According to another particular embodiment, the binding between at least one of the antibodies elicited against the first glycoprotein and each of the glycoforms of the second glycoprotein which are respectively:

- essentially more sialylated than said second glycoprotein,
- essentially less sialylated than said second glycoprotein,

- essentially more branched than said second glycoprotein,
- essentially less branched than said second glycoprotein,
- essentially more fucosylated than said second glycoprotein, and
- essentially less fucosylated than said second glycoprotein,

5 is determined.

According to another particular embodiment, the glycosylation state of the glycoform of the second glycoprotein presents at least two of the following criteria:

- it is essentially more sialylated or less sialylated than said second glycoprotein,
- it is essentially more branched or less branched than said second glycoprotein,
- 10 - it is essentially more fucosylated or less fucosylated than said second glycoprotein.

These modifications act as a combinatory code to generate a remarkable microheterogeneity onto the polypeptide backbone of the protein, affecting both its physicochemical and biological properties. In the case of glycoprotein hormones, inner glycosylation controls subunit association, immunologically and biologically active conformation, while the signal sulphate/sialic acid governs pulsatility and metabolic clearance because it is under the control of the endocrine hypothalamo-pituitary axis.

“Inner glycosylation” typically refers to the invariant pentasaccharide attached to the polypeptide by a N-glycosidic bond. It is known that fucosylation of this core enhances its hydrophobicity and rigidity and, as a result, may alter the conformation of any peptide area covered by the whole glycan.

According to another particular embodiment, the glycosylation state of the glycoform of the second glycoprotein presents one of the following criteria:

- it is essentially more sialylated and more fucosylated than said second glycoprotein, or
- it is essentially more sialylated and less fucosylated than said second glycoprotein, or
- 25 - it is essentially more sialylated and more branched than said second glycoprotein, or
- it is essentially more sialylated and less branched than said second glycoprotein, or
- it is essentially less sialylated and more fucosylated than said second glycoprotein, or
- it is essentially less sialylated and less fucosylated than said second glycoprotein, or
- it is essentially less sialylated and more branched than said second glycoprotein, or
- 30 - it is essentially less sialylated and less branched than said second glycoprotein, or
- it is essentially more branched and more fucosylated than said second glycoprotein, or
- it is essentially more branched and less fucosylated than said second glycoprotein, or
- it is essentially less branched and more fucosylated than said second glycoprotein, or
- it is essentially less branched and less fucosylated than said second glycoprotein.

According to another particular embodiment, the glycosylation state of the glycoform of the second glycoprotein presents three of the following criteria:

- it is essentially more sialylated or less sialylated than said second glycoprotein,
- it is essentially more branched or less branched than said second glycoprotein,
- 5 - it is essentially more fucosylated or less fucosylated than said second glycoprotein.

These modifications generate a remarkable microheterogeneity onto the polypeptide backbone of the protein, affecting both its physicochemical and biological properties during biosynthesis, intracellular migration, secretion and further action at the target tissue. In the case of glycoprotein hormones, this heterogeneity at different levels also controls subunit association, activation of the target receptor, pulsatility and metabolic clearance because it is under the control of the endocrine hypothalamo-pituitary axis.

According to another particular embodiment, the glycosylation state of the glycoform of the second glycoprotein presents one of the following criteria:

- 15 - it is essentially more sialylated, more branched and more fucosylated than said second glycoprotein,
- it is essentially more sialylated, more branched and less fucosylated than said second glycoprotein,
- it is essentially more sialylated, less branched and more fucosylated than said second glycoprotein,
- 20 - it is essentially more sialylated, less branched and less fucosylated than said second glycoprotein,
- it is essentially less sialylated, more branched and more fucosylated than said second glycoprotein,
- it is essentially less sialylated, more branched and less fucosylated than said second glycoprotein,
- 25 - it is essentially less sialylated, less branched and more fucosylated than said second glycoprotein,
- it is essentially less sialylated, less branched and less fucosylated than said second glycoprotein.

30 According to a preferred embodiment, the antibodies elicited against the first glycoprotein bind to the second glycoprotein with an affinity equal to or higher than the binding affinity of said antibodies to the first glycoprotein.

The measure of the affinity of an antibody for a given glycoprotein can be done according to Benkirane, M.M., *et al.*, 1987.

According to another preferred embodiment, at least one lectin fractionation of the second glycoprotein is performed to obtain a glycoform of the second glycoprotein of a determined glycosylation state.

By "lectin" is meant a sugar-binding protein of non-immune origin, which agglutinates cells and/or recognize glycoconjugates. Lectins are classified according to the monosaccharide which inhibits the interaction between the lectin and the targeted glycan or which allows the specific elution of a bound glycan from an immobilized lectin column. The expression "lectin fractionation" means that glycoforms are separated according to their binding affinity for a given lectin insolubilized on a matrix and used as a chromatography column.

Certain lectins have a specific affinity towards a given monosaccharide, like mannose/glucose, fucose, galactose/N-acetylgalactosamine, N-acetyl-glucosamine or N-acetylneuraminic acid.

Advantageously sugar-specific lectin fractionation enables to separate glycoproteins according to their content in said sugar.

According to another preferred embodiment, the lectin is selected from the group comprising mannose-specific lectins, such as the ConA or Lentil lectins, fucose-specific lectins, such as the Ulex lectin, galactose-specific lectins, such as ricin, or sialic acid-specific lectins, such as limulin or the *Sambucus nigra* lectin.

Those lectins are commercially available and well known to the man skilled in the art.

According to another preferred embodiment, at least one enzymatic modification of the second glycoprotein is performed to obtain a glycoform of the second glycoprotein of a determined glycosylation state.

By enzymatic modification is meant that one or more carbohydrate groups are added, removed or modified in a given glycoprotein.

According to another preferred embodiment, the enzymatic modification is carried out by an enzyme selected from the group comprising a glycosidase, in particular a neuraminidase or a fucosidase, or a glycosyltransferase, in particular a sialyl transferase or a fucosyl transferase.

A neuraminidase selectively removes sialic acid from glycoproteins.

A sialyl transferase specifically adds sialyl groups onto a glycoprotein.

A fucosidase selectively removes fucose from glycoproteins.

A fucosyl transferase specifically adds fucosyl groups onto a glycoprotein.

According to a particularly preferred embodiment, a glycoform of the second glycoprotein of a determined glycosylation state is obtained by a combination of at least one enzymatic modification of the second glycoprotein and/or of at least one lectin fractionation.

5 According to another preferred embodiment, a less sialylated glycoform of the second glycoprotein as compared to the second glycoprotein is obtained by neuraminidase treatment of said second glycoprotein.

10 According to another preferred embodiment, a more sialylated glycoform of the second glycoprotein as compared to the second glycoprotein is obtained by sialyltransferase treatment of said second glycoprotein or by neuraminidase treatment followed by sialyltransferase treatment of said second glycoprotein.

According to a particularly preferred embodiment, the sialyltransferase is a  $\alpha$ -2,6 sialyltransferase, in particular a ST6GalII sialyltransferase, more particularly a N-terminal shortened ST6GalII sialyltransferase deleted of at most its first 99 residues, such as represented by SEQ ID NO: 1.

15 Such N-terminal shortened ST6GalII sialyltransferases are notably described in Legaigneur, P., et al. (2001). Preferred shortened human ST6GalII sialyltransferase are  $\Delta$ 1-35 ST6GalII and  $\Delta$ 1-89 ST6GalII (SEQ ID NO: 1) which respectively lack the 35 and 89 first N-terminal residues with respect to the wild type human ST6GalII.

20 According to a preferred embodiment, a less fucosylated glycoform of the second glycoprotein as compared to the second glycoprotein is obtained by lentil fractionation of the second glycoprotein by collecting the fraction which does not bind to lentil and a more fucosylated glycoform of the second glycoprotein as compared to the second glycoprotein is obtained by collecting the fraction which binds to lentil.

25 According to yet another preferred embodiment, a ConA fractionation of the second glycoprotein is performed by collecting three fractions, A, B, and C, the binding of which to ConA is such that,

- C binds to ConA more strongly than B does, and
- B binds to ConA more strongly than A does,

30 the branching state of a given fraction being essentially different from the branching state of the other two fractions.

According to a particular embodiment, in a preliminary step, the antibodies to be screened are classified in pools, each pool being characterized in that two antibodies selected from a same pool can not bind to the same glycoprotein at the same time.

The expression "at the same time" means that both antibodies compete for a similar binding site on said glycoform.

According to another particular embodiment, in a first step, said first step preceding the preliminary step defined above, it is checked that the antibodies elicited against the first glycoprotein bind to the second glycoprotein.

Advantageously, a complete process according to the invention comprises the following steps:

- checking that the antibodies elicited against the first glycoprotein bind to the second glycoprotein,
- 10 - classifying the antibodies to be screened in pools, each pool being characterized in that two antibodies selected from a same pool can not bind to a same glycoform of the second glycoprotein at the same time,
- determining the binding between
  - said antibodies, and
  - 15 - at least one glycoform of the second glycoprotein,

to recover antibodies liable to bind to at least one given glycoform of the second glycoprotein.

According to yet another particular embodiment, the binding of the antibodies to the first glycoprotein, to the second glycoprotein and to the glycoforms of the second glycoproteins is determined by using immunoassays, in particular immunoassay formats using an amplification system for detection, such as an ELISA.

According to a much preferred embodiment, the immunoassay is a sandwich immunoassay, in particular a sandwich ELISA test, comprising the following steps:

- fixing a capture antibody, selected from a pool such as defined above, onto a support,
- contacting a glycoprotein, corresponding to the first glycoprotein, to the second glycoprotein or to the glycoforms of the second glycoprotein, to said capture antibody, to form, if adequate, a capture antibody-glycoprotein binary complex,
- 25 - contacting a tracer antibody, selected from a pool such as defined above, provided said pool is different from the one used for the selection of said capture antibody, to said capture antibody-glycoprotein binary complex, to form, if adequate, a capture antibody-glycoprotein-tracer antibody ternary complex,
- 30 - detecting the tracer antibody for measuring the number of ternary complexes.

The expression "capture antibody" relates to an antibody which is covalently or non-covalently adsorbed onto a support, a so called solid-phase, such as the wall of a

microtitration well, so as to form a capture antibody-glycoprotein complex bound to the solid phase.

The expression "tracer antibody" relates to an antibody which can bind said glycoprotein once it is linked to the capture antibody, said tracer antibody being coupled to a detection system. For instance, the tracer antibody can be linked to biotin and be detected using an avidin-enzyme complex, such as alkaline phosphatase or peroxidase, which may be used to activate a fluorogenic and/or a chromogenic substrate, such as p-nitro phenylphosphate, 5 bromo-4-chloro-3-indoylphosphate or 1,2 phenyl-enediamine/hydrogen peroxide using an appropriate buffer. Any other enzymatic reaction which is readable with a microtiter spectrofluorometer or spectrophotometer can also be used.

According to another particular embodiment, the first glycoprotein and the second glycoprotein are similar.

The term "similar" means that according to this embodiment the first and the second glycoprotein are the same, that is, they share the same amino acid sequence and the same glycosylation pattern.

According to this particular embodiment, antibodies are elicited against a given glycoprotein, and then the binding of said antibodies with glycoforms of said glycoprotein is determined.

According to yet another particular embodiment, the first glycoprotein and the second glycoprotein originate from different natural tissues and/or fluids.

Tissues and fluids according to the invention notably encompass endocrine tissues, such as the pituitary gland, placenta or endocrine tumors, or fluids such as blood, plasma, serum or urine for instance.

According to still another particular embodiment, the first glycoprotein originates from a natural tissue and the second glycoprotein is a recombinant protein.

Advantageously, the recombinant glycoprotein is produced in mammalian cell lines, in particular Chinese Hamster Ovary (CHO) or human cell lines.

According to a more particular embodiment, the first glycoprotein originates from a natural tissue and the second glycoprotein is a mutated recombinant protein.

By "mutated recombinant protein" is meant that the sequence of second glycoprotein has been modified, with respect to the sequence of the first glycoprotein, by substitution, insertion or deletion of at least one amino acid, provided said second glycoprotein retains hormone-specific immunoreactivity and biological activity.

According to a further particular embodiment, the first glycoprotein is a N-linked glycoprotein, such as TSH, in particular pituitary TSH, LH, FSH, or placental hCG.

Thyroid-Stimulating Hormone (TSH) is a member of the glycoprotein hormone family, which includes pituitary (FSH, LH) and placental (hCG) gonadotropins. These hormones are composed of two different non-covalently linked subunits consisting of a common  $\alpha$ -subunit (92 aa in human) and an unique  $\beta$ -subunit (112-118 aa in human) which confers biological and immunological specificity to the hormone heterodimer. TSH possesses two glycans attached to Asn-52 and Asn-78 of the human  $\alpha$ -subunit whereas the  $\beta$ -subunit has a single glycan linked to Asn-23.

According to a much preferred embodiment, the first glycoprotein is pituitary TSH and the second glycoprotein is a recombinant TSH.

According to another particular embodiment, the first glycoprotein is pituitary or blood human TSH and the second glycoprotein is a recombinant human TSH, in particular a recombinant human TSH produced in mammalian cells.

In a particularly preferred embodiment the recombinant human TSH is produced by CHO cells.

The present invention further relates to the use of a glycosylation-specific antibody as screened by the above defined process, for the binding or the purification of given glycoforms of the second glycoprotein.

In particular the above glycosylation-specific antibodies can be used for immunodetecting a given glycoform of the second glycoprotein or for immunoassaying the concentration of a given glycoform of the second glycoprotein, in samples, in particular human biological samples.

The above glycosylation-specific antibodies can also be used to purify a given glycoform of the second glycoprotein, for instance by using affinity chromatography, from samples derived either from biological samples or from culture media of cells lines producing recombinant glycoproteins.

According to a preferred embodiment, antibodies R2 and/or OCD1 are used for the binding or the purification of TSH circulating in blood of healthy subjects or of patients suffering from thyroid diseases, such as hypothyroidism, or from non-thyroid diseases coupled to altered levels of TSH, such as endocrine tumors, chronic renal failure or non-thyroid illnesses.

The present invention also relates to a kit for assaying specific glycoforms of the first glycoprotein, characterized in that it comprises:

- at least one antibody such as screened according to the above defined process,
- at least one glycoprotein calibrant selected from the group comprising the first glycoprotein, the second glycoprotein, and a given glycoform of the second glycoprotein such as defined above.

5           The expression "glycoprotein calibrant" refers to a glycoprotein which can be used as a standard for the calibration of said kit.

          According to a preferred embodiment, the invention relates to a kit as defined above, for assaying TSH in a biological sample, characterized in that it comprises:

- at least one antibody selected from the group comprising:

10           pool I antibodies: B1, B2, S04, S09, R1 and BC27,

          pool II antibodies: OCD1 and R2,

          pool III antibodies: B3 and S06,

as capture antibody, and at least one antibody selected from the group comprising:

          pool I antibodies: B1, B2, S04, S09, R1 and BC27,

15           pool II antibodies: OCD1 and R2,

          pool III antibodies: B3 and S06,

as tracer antibody, provided that the capture antibody and the tracer antibody do not belong to a same pool, and

20           -at least one glycoprotein calibrant which is selected from the group comprising pituitary TSH, substantially unsialylated and/or substantially unfucosylated TSH.

          Several immunoassays formats are defined herein depending on the capture antibody / tracer antibody couple used. The choice of a given antibody couple itself depends on the targeted epitopic regions. Three main epitopic region have been defined on TSH in the present invention:

25           region I, which is recognized by pool I antibodies B1, B2, S04, S09, R1 and BC27,

          region II, which is recognized by pool II antibodies OCD1 and R2,

          region III, which is recognized by pool III antibodies B3 and S06.

          Alternatively region I can be subdivided in regions Ia and Ib, which are respectively recognized by pool Ia antibodies and pool Ib antibodies.

30           Pool Ia antibodies comprise: S04, B1 and BC27.

          Pool Ib antibodies comprise: B2, S09, and R1.

          Those antibodies are: OCD1 from Ortho-Clinical Diagnostics, (USA), BC27 commercially available from Beckman-Coulter (USA), R1 and R2 from Roche Diagnostics

(G), S04, S06 and S09 commercially available from Seradyn (USA), B1, B2 and B3 from Bayer Diagnostics (G).

More precisely, the panel of monoclonal antibodies is as follows:

- OCD1 (ref. 191 29 97) is from Ortho-Clinical Diagnostics, (USA),
- 5 - BC27 (ref. IM0370) is commercially available from Beckman-Coulter (Immunotech, France),
- R1 (ref. 11 367 978) and R2 (ref. 10 767 778) are from Roche Diagnostics (Germany),
- S04 (ref. MIT0404), S06 (ref. MIT0406) and S09 (ref. MIT0409) are commercially available from Seradyn (USA),
- 10 - B1, B2 and B3 (ref. 04911359) are from Bayer Diagnostics (Germany).

According to a preferred embodiment, the invention relates to a kit as defined above, for assaying TSH in a biological sample, characterized in that it comprises:

- at least one antibody selected from the group comprising BC27, S04, B1, S09, R1, and B2, as capture antibody and at least one antibody selected from the group comprising S06 and B3, as tracer antibody, or
- 15 - at least one antibody selected from the group comprising S04, B1 and BC27 as capture antibody and at least one antibody selected from the group comprising B2, S09, and R1 as tracer antibody, or
- at least one antibody selected from the group comprising S06 and B3 as capture antibody and at least one antibody selected from the group comprising BC27, S04, B1, S09, R1, and B2 as tracer antibody, and
- 20 -at least one glycoprotein calibrant which is selected from the group comprising pituitary TSH, substantially unsialylated and/or substantially unfucosylated TSH.

This kit is advantageous for assaying TSH from patients with thyroid dysfunction: this immunoassay format is essentially glycosylation independent, that is, antibody binding is not affected by changes in the glycosylation pattern of the protein antigens to be assayed.

In the above defined kit, it is advantageous to use immunoassay formats I/III or preferably III/I, that is to say formats wherein the capture antibody binds to epitopic region I and the tracer antibody binds to epitopic region III, or formats wherein the capture antibody binds to epitopic region III and the tracer antibody binds to epitopic region I.

This kit is advantageous for assaying TSH from healthy subjects or from patients suffering from thyroid diseases coupled to altered levels of TSH in that it is satisfactorily calibrated by a pituitary extract and/or IRP pituitary standard.

According to a preferred embodiment, the invention relates to a kit as defined above, for assaying TSH in a biological sample, characterized in that it comprises:

- at least one antibody selected from the group comprising BC27, S04, B1, S09, R1, and B2, as capture antibody,

5 - at least one antibody selected from the same group comprising OCD1 and R2 as tracer antibody, and

-at least one glycoprotein calibrant which is selected from the group comprising recombinant TSH, and a glycoform of recombinant TSH which is substantially more sialylated and/or less fucosylated than said recombinant TSH.

10 This kit is advantageous for assaying TSH from healthy subjects or from patients suffering from thyroid diseases, such as hypothyroidism, or from non-thyroid diseases coupled to altered levels of TSH; in this kit the immunoassay involved is of format I/II, which is essentially sialylation dependent, that is, antibody binding to glycoforms of a given TSH having an increased sialylation state as compared to said TSH, is increased.

15 According to a preferred embodiment, the invention relates to a kit as defined above, for assaying TSH in a biological sample, characterized in that it comprises:

- at least one antibody selected from the group comprising S06 and B3, as capture antibody,

- at least one antibody selected from the same group comprising OCD1 and R2 as tracer antibody, and

20 -at least one glycoprotein calibrant which is selected from the group comprising a glycoform of recombinant TSH which is substantially more sialylated and/or more fucosylated than said recombinant TSH.

This kit is advantageous for assaying TSH from healthy subjects or from patients suffering from thyroid diseases, such as hypothyroidism, or from non-thyroid diseases  
25 coupled to altered levels of TSH; in this kit, the immunoassay involved is of format III/II, which is largely glycosylation dependent in that it may exhibit optimal binding capacity of TSH with altered and/or disease-related glycosylation.

A glycosylation-dependent assay is thereby defined by the use of antibodies which are able to capture the largest array of TSH glycoforms. Such assays can typically accommodate  
30 variation in sialic acid and/or fucose content and as a result, provide a better estimation of changes in hormone level compared to said glycosylation-independent assay.

The present invention also relates to a process for the preparation of a glycoform of a recombinant human TSH produced by mammalian cells, characterized in that said recombinant human TSH is sialylated by an  $\alpha$ -2,6 sialyltransferase, in particular a human

ST6GalII sialyltransferase, more particularly a N-terminal shortened human ST6GalII sialyltransferase deleted of at most its first 99 residues, such as represented by SEQ ID NO: 1, to yield an oversialylated glycoform of the recombinant TSH bearing  $\alpha 2,3$  and  $\alpha 2,6$  sialyl moieties.

5 In a preferred embodiment, the recombinant human TSH produced by mammalian cells, is produced by CHO cells.

In the human organism, TSH carries essentially only sulfated groups but has a low content in  $\alpha 2,3/6$  linked sialic acid, the ratio of these sugars controlling hormone duration in blood. Thus it is advantageous to add  $\alpha 2,6$  sialyl groups to the recombinant TSH, since most  
10 cell lines used for its production lack the adequate  $\alpha 2,6$  sialyltransferase. For instance the recombinant TSH produced by the CHO cell line carries essentially only  $\alpha 2,3$  sialyl groups.

In a particular embodiment of the above defined glycoform preparation process, the recombinant human TSH is first treated by a neuraminidase, in particular a *Clostridium perfringens* or a *Vibrio cholerae* neuraminidase, to give a substantially unsialylated TSH, and  
15 then submitted to sialylation, to yield a resialylated glycoform of the recombinant TSH bearing essentially only  $\alpha 2,6$  sialyl moieties.

The present invention also relates to a process for the preparation of a glycoform of a recombinant human TSH produced by mammalian cells, characterized in that said recombinant human TSH is submitted to a lentil fractionation, to give a lentil unbound  
20 fraction and a lentil bound fraction, the lentil unbound fraction being retained to yield a substantially unfucosylated glycoform of the recombinant TSH and the lentil bound fraction being retained to yield a glycoform which is substantially more fucosylated than said recombinant TSH.

In a particular embodiment of the above mentioned glycoform preparation process:  
25 - the recombinant human TSH is submitted to neuraminidase treatment, in particular a *Clostridium perfringens* or a *Vibrio cholerae* neuraminidase, prior to lentil fractionation, or  
- the lentil bound fraction or the lentil unbound fraction of the recombinant human TSH is submitted to neuraminidase treatment,  
to yield a substantially unsialylated substantially unfucosylated glycoform of the recombinant  
30 human TSH or a glycoform of the recombinant human TSH which is substantially unsialylated and substantially more fucosylated than said recombinant human TSH.

In a preferred embodiment of the above defined glycoform preparation process:  
- the recombinant human TSH is submitted to sialylation to give an oversialylated glycoform of the recombinant human TSH, or both to neuraminidase treatment and to sialylation to give

a resialylated glycoform of the recombinant human TSH, prior to lentil fractionation of said glycoform, or

- the lentil unbound fraction or the lentil bound fraction of the recombinant human TSH is submitted to sialylation, or sequentially to both neuraminidase treatment and sialylation,

5 to yield a substantially unfucosylated oversialylated or resialylated glycoform of the recombinant human TSH or a glycoform of the recombinant human TSH which is oversialylated or resialylated and substantially more fucosylated than said recombinant human TSH.

10 According to the invention, an oversialylated glycoform of a given glycoprotein comprises both the sialyl groups initially present on said glycoprotein and the new sialyl groups which have been added by the sialyltransferase treatment.

According to the invention, a resialylated glycoform of a given glycoprotein presents an homogenous sialylation state corresponding to the sialyltransferase which has been used; in particular, if an  $\alpha 2,6$  sialyltransferase is used the resialylated glycoform comprises  
15 essentially only  $\alpha 2,6$  sialyl groups.

The present invention also relates to a glycoform of recombinant human TSH such as obtainable according to the above mentioned glycoform preparation processes.

The present invention also relates to an oversialylated glycoform of a recombinant human TSH produced by mammalian cells which comprises from about 70% to about 100%  
20  $\alpha 2,3$  and  $\alpha 2,6$  sialyl groups, in particular from about 70% to about 85 %  $\alpha 2,3$  sialyl groups and from about 15% to about 30%  $\alpha 2,6$  sialyl groups.

As intended herein, the sialylation percentage of a given glycoform relates to the number of sialyl groups it carries with respect to the maximum number of sialyl groups it is liable to carry. This sialylation percentage can be measured by sugar analysis and mass  
25 spectrometry as described in the following Examples. By way of example, in the case of a recombinant human TSH produced in CHO cells, the average maximum number of sialyl groups is 9.

It is possible to differentiate the percentage of  $\alpha 2,3$  and  $\alpha 2,6$  sialyl groups by using an  $\alpha 2,3$ -specific neuraminidase and/or an  $\alpha 2,6$ -specific neuraminidase.

30 The present invention also relates to a resialylated glycoform of a recombinant human TSH produced by mammalian cells which comprises from about 70% to about 100 %  $\alpha 2,6$  sialyl groups.

The present invention also relates to a glycoform of a recombinant human TSH produced by mammalian cells which comprises essentially no fucose.

The present invention also relates a glycoform of a recombinant human TSH produced by mammalian cells which comprises from about 30% to about 100% fucose.

As intended herein, the fucosylation percentage of a given glycoform relates to the number of fucose groups it carries with respect to the maximum number of fucose groups it is liable to carry, that is 3. This fucose percentage can be measured by sugar analysis and mass spectrometry as described in the following Examples.

In a preferred embodiment, the glycoform of recombinant human TSH produced by mammalian cells comprises essentially no fucose and no sialyl groups.

In another preferred embodiment, the glycoform of recombinant human TSH produced by mammalian cells comprises essentially no sialyl groups and from about 30% to about 100% fucose.

In another preferred embodiment, the glycoform of recombinant human TSH produced by mammalian cells comprises from about 70% to about 100%  $\alpha$ 2,3 sialyl and  $\alpha$ 2,6 sialyl groups, in particular from about 70% to about 85 %  $\alpha$ 2,3 sialyl groups and from about 15% to about 30%  $\alpha$ 2,6 sialyl groups, and essentially no fucose.

In another preferred embodiment, the glycoform of recombinant human TSH produced by mammalian cells comprises from about 70% to about 100 %  $\alpha$ 2,6 sialyl groups and essentially no fucose.

In another preferred embodiment, the glycoform of recombinant human TSH produced by mammalian cells comprises from about 70% to about 100%  $\alpha$ 2,3 sialyl and  $\alpha$ 2,6 sialyl groups, in particular from about 70% to about 85 %  $\alpha$ 2,3 sialyl groups and from about 15% to about 30%  $\alpha$ 2,6 sialyl groups and from about 30% to about 100% fucose.

In another preferred embodiment, the glycoform of recombinant human TSH produced by mammalian cells comprises from about 70% to about 100 %  $\alpha$ 2,6 sialyl groups and from about 30% to about 100% fucose.

In a preferred embodiment of the above mentioned glycoforms, the recombinant human TSH produced by mammalian cells, is produced by CHO cells.

These above mentioned glycoforms of recombinant TSH are advantageous in that their recognition pattern by anti-TSH antibodies is highly similar to the recognition pattern of the natural plasma TSH found in the human organism.

The present invention also relates to a kit for assaying specific glycoforms of a first glycoprotein, characterized in that it comprises at least one antibody such as screened according to the above mentioned glycoform-specific antibody screening process.

According to a preferred embodiment of the above defined kit, the kit is intended for assaying TSH in a biological sample and is characterized in that it comprises:

- at least one capture-antibody selected from pools Ia, Ib, or III,
- at least a tracer-antibody selected from pools Ib, II, or III,

5 provided that the capture-antibody and the tracer-antibody do not belong to the same pool, wherein:

- pool Ia is defined as being the pool of antibodies which can not bind to TSH once antibody, B1, S04 or BC27 has already been bound to it,
- 10 - pool Ib is defined as being the pool of antibodies which can not bind to TSH once antibody B2, R1 or S09 has already been bound to it,
- pool II is defined as being the pool of antibodies which can not bind to TSH once antibody OCD1 or R2 has already been bound to it,
- pool III is defined as being the pool of antibodies which can not bind to TSH once antibody B3 or S06 has already been bound to it.

15 In another preferred embodiment, the above defined kit comprises:

- a capture-antibody selected from pool Ia and a tracer antibody selected from pool Ib, or
- a capture-antibody selected from pool Ia and a tracer antibody selected from pool II, or
- 20 - a capture-antibody selected from pool Ib and a tracer antibody selected from pool II, or
- a capture-antibody selected from pool Ia and a tracer antibody selected from pool III, or
- a capture-antibody selected from pool Ib and a tracer antibody selected from pool III, or
- 25 - a capture-antibody selected from pool III and a tracer antibody selected from pool II.

In a particularly preferred embodiment, the above defined kit further comprises a calibrant selected from the list comprising:

pituitary human TSH, recombinant human TSH produced by mammalian cells, a glycoform of recombinant human TSH produced by mammalian cells which substantially less sialylated  
30 than said recombinant human TSH, a glycoform of recombinant human TSH produced by mammalian cells which is substantially more sialylated and/or less fucosylated than said recombinant human TSH, and a glycoform of recombinant human TSH as defined above.

As intended herein a "calibrant" relates to a glycoprotein which presents an antibody binding pattern essentially similar to that of the glycoprotein intended to be assayed by the kit. Thus, the calibrant is used to standardize the immunological assays.

5 The present invention also relates to the use of a glycoprotein selected from the list comprising:  
a glycoform of recombinant human TSH produced by mammalian cells which is substantially less sialylated than said recombinant human TSH, a glycoform of recombinant human TSH produced by mammalian cells which is substantially more sialylated and/or less fucosylated than said recombinant human TSH, and a glycoform of recombinant human TSH as defined  
10 above.  
for calibrating TSH immunoassays.

The present invention also relates to a shortened human ST6GalII sialyltransferase lacking the first 89 N-terminal residues with respect to the wild type human ST6GalII, as represented by SEQ ID NO: 1.

15 Such a shortened ST6GalII sialyltransferase is advantageous over that of the prior art, because of its increased solubility and of its superior activity.

### Description of the Figures

#### Figure 1A, Figure 1B, Figure 1C and Figure 1D

Figures 1A to 1D represent the typical glycosylation patterns of the major glycoforms found for N-linked glycoproteins (Figure 1A), human pituitary TSH (pitTSH) (Figure 1B), the recombinant TSH (recTSH) used herein (Figure 1C), and the putative human plasma TSH thought to be the disease-related form of TSH circulating in hypothyroid patient (Figure 1D). Asn-X-Ser/Thr corresponds to the consensus peptide sequence for N-glycosylation. NeuAc corresponds to sialic acid linked to the glycan chain by  $\alpha 2,3$  or  $\alpha 2,6$  linkages. The grey diamond shapes correspond to fucose, the white squares to N-acetylglucosamine, the grey circles to mannose, the black circles to galactose and the grey triangle to N-acetylgalactosamine.

#### Figure 2A, Figure 2B, Figure 2C and Figure 2D

Figure 2A-D represent the epitope screening of recTSH as obtained by a sandwich ELISA test, using antibodies BC27, B1, B2, B3, R1, R2, S04, S06, and S09 as capture antibodies and biotinylated-OCD1 as a tracer antibody (Figure 2A), biotinylated-BC27 as a tracer antibody (Figure 2B), biotinylated-S04 as a tracer antibody (Figure 2C), biotinylated-S06 as a tracer antibody (Figure 2D). In figure 2A a negative control is also provided (T(-)).

#### Figure 3

Figure 3 is a simplified diagrammatic representation of the various epitopic regions (I, II and III) recognized by the BC27, B1, B2, B3, R1, R2, S04, S06, S09 and OCD1 antibodies, as deduced from the epitope screening of recTSH. S06 and B3 recognize overlapping epitopes located in epitopic region III; OCD1 and R2 recognize different epitopes located in epitopic region II; S09, R1 and B2 recognize virtually similar epitopes located in epitopic region I, which are different from the epitope recognized by BC27 and the essentially similar epitopes recognized by S04 and B1, in the same epitopic region I.

#### Figure 4A, Figure 4B, Figure 4C, Figure 4D, Figure 4E and Figure 4F

Figures 4A to 4F represent sandwich ELISA assays of IRP pitTSH (black diamond shapes), IRP recTSH (black squares) and oversialylated recTSH (white squares). The horizontal axis represents the concentration of TSH (in IU/L) and the vertical axis the OD at 405 nm. Figure 4A corresponds to a I/II format (capture antibody BC27, tracer antibody OCD1), figure 4B

corresponds to a II/I format (capture antibody R2, tracer antibody S04), figure 4C corresponds to a I/III format (capture antibody BC27, tracer antibody S06), figure 4D corresponds to a III/I format (capture antibody S06, tracer antibody S04), figure 4E corresponds to a II/III format (capture antibody R2, tracer antibody S06) and figure 4F corresponds to a III/II format (capture antibody S06, tracer antibody OCD1). As intended herein 1  $\mu$ g of TSH corresponds to 4.93 mIU.

#### **Figure 5A, Figure 5B and Figure 5C**

Figures 5A-C represent ELISA assays of various TSH preparations varying in sialic acid content. The horizontal axis represents the concentration of TSH (in IU/L) and the vertical axis the OD at 405 nm. The black squares correspond to IRP recTSH, the black triangles to asialo-recTSH, the black diamond shapes to IRP pitTSH, the white squares to oversialylated recTSH (recTSH sialylated with  $\alpha$ 2,6 sialyltransferase) and the white triangles to resialylated recTSH (asialo-recTSH treated with  $\alpha$ 2,6 sialyltransferase). Figure 5A represents the results of the S06-BC27 sandwich, figure 5B the results of the BC27-OCD1 sandwich and figure 5C a control measurement of  $\alpha$ 2,6-linked sialic acid using *Sambucus nigra* (SNA) lectin binding. As intended herein 1  $\mu$ g of TSH corresponds to 4.93 mIU.

#### **Figure 6A and Figure 6B**

Figure 6A represents the kinetics of OCD1 binding to TSH preparations in a BC27-OCD1 sandwich ELISA assay. The horizontal axis represents the incubation time with OCD1 in minutes and the vertical axis the OD at 405 nm. The black squares correspond to IRP recTSH, the black triangles to asialo-recTSH, the black diamond shapes to IRP pitTSH, the white squares to oversialylated recTSH (recTSH treated with  $\alpha$ 2,6 sialyltransferase) and the white triangles to resialylated recTSH (asialo-recTSH treated with  $\alpha$ 2,6 sialyltransferase).

Figure 6B represents a SNA binding assay of the previous TSH preparation (horizontal axis) as measured by the OD at 405 nm (vertical axis).

#### **Figure 7A and Figure 7B**

Figures 7A and 7B represent lectin affinity chromatography profiles for recTSH detected with III/I format (S06-BC27). In figure 7A an unbound fraction (eluted by TBS) and a bound fraction (eluted by 500 mM  $\alpha$ -methylmannopyranoside) are shown. The bound fraction is enriched in fucosylated recTSH as compared to the unbound fraction.

In Figure 7B, three fractions are shown, an unbound fraction (eluted by TBS), a weakly bound fraction (eluted by 10 mM  $\alpha$ -methylglucopyranoside) and a firmly bound fraction (eluted by 500 mM  $\alpha$ -methylmannopyranoside). The three fractions differ from each other with respect to their respective branching states.

5

#### **Figure 8A and Figure 8B**

Figures 8A and 8B represent sandwich ELISA assays of recTSHs purified by lentil affinity chromatography using the BC27-OCD1 format (figure 8A) and the S06-S04 format (figure 8B). The horizontal axes represent the concentration of TSH (in IU/L) and the vertical axes represent the OD at 405 nm. The black squares represent IRP recTSH, the black cross IRP pitTSH, the black diamond shapes the lentil unbound fraction of recTSH and the black triangles the lentil bound fraction of recTSH. As intended herein 1  $\mu$ g of TSH corresponds to 4.93 mIU.

10

#### **Figure 9A and Figure 9B**

Figures 9A and 9B represent the kinetics of antibody binding to lentil-chromatography fractions for S06 binding in S06-S04biot assay (figure 9A) and for S04 binding in S06-S04biot assay (figure 9B). The horizontal axes represent the time in minutes and the vertical axes represent the OD at 405 nm. The black crosses represent IRP pitTSH, the black squares recTSH, the black diamond shapes the lentil unbound fraction and the black triangles the lentil bound fraction.

20

#### **Figure 10A, Figure 10B, Figure 10C and Figure 10D**

Figures 10A-D represent the effect of the TSH branching pattern on antibody binding using the BC27-OCD1 (figure 10A), S06-OCD1 (figure 10B), S06-S04 (figure 10C) and BC27-S06 (figure 10D) formats. The horizontal axis represents the concentration of TSH (in IU/L) and the vertical axis the OD at 405 nm. The black diamond shapes correspond to the ConA unbound fraction, the black squares to the weakly bound fraction, the black triangles to the firmly bound fraction, and the black crosses to IRP pitTSH. As intended herein 1  $\mu$ g of TSH corresponds to 4.93 mIU.

25  
30

#### **Figure 11A and Figure 11B**

Figure 11A represents the percentage of oversialylated recTSH (vertical axis) in the unbound fraction (black bars), the weakly bound fractions (white bars) or the firmly bound fractions

(hatched bars) of a ConA fractionation of oversialylated recTSH according to the indicated sandwich ELISA formats.

Figure 11B represents the percentage of oversialylated recTSH (vertical axis) in the unbound fraction (black bars), or the bound fractions (hatched bars) of a lentil fractionation of oversialylated recTSH according to the indicated sandwich ELISA formats.

#### **Figure 12A, Figure 12B and Figure 12C**

Figures 12A-C represent the plateau charge (vertical axis, OD at 405 nm) of the indicated sandwich ELISA formats (horizontal axis) for IRP pitTSH (figure 12A), IRP recTSH (figure 12B) and oversialylated recTSH (figure 12C).

#### **Figure 13A and Figure 13B**

Figures 13A and 13B represent the ELISA assays of TSH varying in core-fucose content. The horizontal axes represent the volume of lentil fraction tested (in  $\mu\text{L}$ ) and the vertical axes the OD at 405 nm. Diamonds correspond to the BC27-OCD1 format, squares to S06-S04, and triangles to S06-OCD1. Figure A represents the results obtained with the unbound fraction of lentil chromatography (non fucosylated oversialylated recTSH), and figure B the results obtained with the bound fraction of lentil chromatography (fucosylated oversialylated recTSH).

#### **Figure 14A, Figure 14B, Figure 14C, Figure 14D**

Figures 14A to 14D represent the comparative analysis of TSHs from pituitary and recombinant origin based on MALDI-TOF mass spectrometry. Subunits of a highly purified preparation of pituitary TSH (Figure 14A) were identified using free subunits. Recombinant TSH is represented in Figure 14B, asialo-recTSH in Figure 14C and recTSH enzymatically sialylated with the engineered human  $\alpha 2,6$ -sialyltransferase ST6GalII produced in CHO cells in Figure 14D.

#### **Figure 15A, Figure 15B, Figure 15C, Figure 15D and Figure 15E**

Figures 15A-15D represent the epitope screening of pituitary TSH (pitTSH) and recombinant TSH (recTSH) as obtained by a sandwich ELISA test, using antibodies BC27, B1, B2, B3, R1, R2, S04, S06, and S09 as capture antibodies and biotinylated-OCD1 as a tracer antibody (Figure 15A), biotinylated-BC27 as a tracer antibody (Figure 15B), biotinylated-S04 as a tracer antibody (Figure 15C), biotinylated-S06 as a tracer antibody (Figure 15D).

Figure 15E represents a schematic map of the various epitopic regions of TSH designed as I, II and III respectively. Binding experiments were conducted at equilibrium in presence of saturating conditions of TSH (10 ng). S06 and B3 recognize overlapping epitopes located in epitopic region III; OCD1 and R2 recognize different epitopes located in epitopic region II. S04 and B1 recognized similar epitopes in the epitopic region I, overlapping the area bound by BC27 (region Ia). Together with S09, R1 and B2 which target virtually similar epitopes which are different from the epitope recognized by BC27 as well as B1 and S04, but still in region I (region Ib).

10 **Figure 16A, Figure 16B, Figure 16C, Figure 16D, Figure 16E, and Figure 16F**

Figures 16A, 16B and 16C represent the maximal binding capacity of various TSH preparations in the I-II, I-III and II-III formats. Maximal values were deduced from Figures 4A to 4F (vertical axis) for the 2<sup>nd</sup> IRP pitTSH (Figure 16A), the 1<sup>st</sup> IRP recTSH (Figure 16B) and oversialylated recTSH (Figure 16C) respectively, and their respective EC50 values for 2<sup>nd</sup> IRP pitTSH in Figure 16D, 1<sup>st</sup> IRP recTSH in Figure 16E and oversialylated recTSH in Figure 16F.

**Figure 17**

Figure 17 represents the distribution of oversialylated recTSH on Lentil-Sepharose has been expressed as percentage of the total recovery in assays as indicated. All assays have been calibrated with recTSH on a molar basis. UB refers to unbound (non fucosylated) fractions and B to bound (fucosylated) fractions. Binding experiments were conducted overnight at equilibrium at 4°C.

25 **Figure 18**

Figure 18 represents the distribution of oversialylated recTSH on Con A-Sepharose expressed as a percentage of total recovery. The indicated assays have been calibrated with the recTSH on a molar basis and incubated overnight at equilibrium at 4°C. UB refers to the unbound fraction (TSH with multiantennary glycans), WB to the weakly bound fraction of TSH containing at least one biantennary glycan and FB to the firmly bound TSH fraction which reflects the cooperative binding of several glycans by the tetravalent lectin.

**Figure 19A, Figure 19B, Figure 19C, Figure 19D, Figure 19E, Figure 19F, Figure 19G, Figure 19H, Figure 19I, Figure 19J, Figure 19K, Figure 19L, Figure 19M, Figure 19N, and Figure 19O**

Figures 19A to 19F represent the quantitative epitope oriented mapping of pituitary, recombinant and blood TSH using tracer antibodies directed against epitope I. Figures 19A, 19C and 19E were obtained with biotinylated BC27 antibody as tracer, and Figures 19B, 19D and 19F with biotinylated S04 antibody as tracer. Binding experiments were carried out at the EC50 (2ng TSH) at equilibrium. Capture antibodies are presented on the horizontal axes and OD at 405nm on the vertical axes. Pituitary TSH is represented in white, recombinant in black and blood TSH in grey.

Figures 19G to 19L represent the quantitative epitope oriented mapping of pituitary, recombinant and blood TSH using tracer antibodies directed against epitope II. Figures 19G, 19I and 19K were obtained with OCD1 antibody as tracer, and Figures 19H, 19J and 19L with biotinylated R2 antibody as tracer. Binding experiments were carried out at the EC50 (2ng TSH) at equilibrium. Capture antibodies are presented on the horizontal axes and OD at 405nm on the vertical axes. Pituitary TSH is represented in white, recombinant in black and blood TSH in grey.

Figures 19M-19O represent the quantitative epitope oriented mapping of pituitary, recombinant and blood TSH using tracer antibodies directed against epitope III. Figures 19M, 19N and 19O were obtained with S06 antibody as tracer. Binding experiments were carried out at the EC50 (2ng TSH) at equilibrium. Capture antibodies are presented on the horizontal axes and OD at 405nm on the vertical axes. Pituitary TSH is represented in white, recombinant in black and blood TSH in grey.

**Figure 20A, Figure 20B and Figure 20C**

Figures 20A-20C summarize the immunological behavior of the various TSHs in the 32 formats described by the invention. Figure 20A describes the respective potency of recTSH compared to pitTSH. Figure 20B describes the respective potency of bloodTSH compared to pitTSH. Figure 20C describes the respective potency of bloodTSH compared to recTSH.

## Examples

### Example 1

#### **Immunological characterization of a recombinant glycoprotein: TSH**

5

A panel of monoclonal antibodies elicited against human pituitary TSH (pitTSH) were screened against glycoforms of a preparation of recombinant TSH (recTSH), each glycoform corresponding to a determined glycosylation state defined by a modification of the glycosylation pattern typically in either sialylation, fucosylation or branching.

10

The following monoclonal antibodies elicited against human pituitary TSH were used: OCD1 (Ortho-Clinical Diagnostics, USA), BC27 (Becton-Dickinson, USA), R1 and R2 (Roche Diagnostics), S04, S06 and S09 (Seradyn, USA), B1, B2 and B3 (Bayer Diagnostics).

Prior to use, the antibodies were biotinylated according to the manufacturer recommendations as follows: 200  $\mu\text{g}$  mAb to be biotinylated, were incubated with 6  $\mu\text{g}$  biotin-7-NHS/DMSO, 2 h at room temperature during gentle stirring. Remaining non reacted biotin-7-NHS was separated by gel filtration on a Sephadex G-25 column previously blocked and washed. Labeled antibody was then eluted with PBS solution, the extinction at 280nm of collected fractions was measured and conjugates concentration determined according to  $\text{OD}_{280} = \epsilon \times C \times l$  with extinction coefficient  $\epsilon = 1.35$  for mAbs. Eluates containing the conjugate were then pooled.

15

20

The recombinant TSH (recTSH) was from Seradyn (USA), and the pituitary TSH (pitTSH) was from Biogenesis (UK).

25

The following materials and reagents were also used. IRP (International Reference Preparations) standards (2<sup>nd</sup> IRP pitTSH (80/558) and 1<sup>st</sup> IRP recTSH (94/674)) were ordered at the NISBC (National Institute for Biological Standards and Control, UK). Neuraminidase, asialofetuin, bovine serum albumin (BSA),  $\alpha$ -methyl glucopyranoside,  $\alpha$ -methylmannopyranoside, cacodylic acid, Triton X-100, CMP-NeuAc, p-NitroPhenylphosphate (p-NPP) and Tween 20 were purchased from SIGMA. SNA-biotin was from Vector Laboratories and the streptavidin-alkaline phosphatase conjugate from Jackson ImmunoResearch Laboratories. Purified rat liver ST6Gal I and biotin labeling kit were from Roche. ConA-Sepharose and Lentil-Sepharose were from Pharmacia Biotech, and

30

chromatography columns from VWR International as well as microtiter 96-wells plates. All culture reagents were from INVITROGEN-Life Technologies. The Micro BCA™ Protein Assay Kit was from Pierce (Perbio).

5           The commercial preparation of recTSH was investigated to identify the whole array of glycan structure present in the product. Since many structural features were reported to differ between pitTSH and various preparations of recTSH (Grossmann, M. *et al.*, 1995; Canonne, C. *et al.*, 1995) as well as between the pituitary stock and the circulating hormone in normal subjects or patients with thyroid disorders (Papandreou, M-J., *et al.*, 1993), it was of definite  
10 interest to understand how far glycosylation of recTSH may be altered compared to the native hormone. **Figures 1B- 1D** thus represents the first elucidation of the kind applied to TSH.

          The glycosylation pattern of the recTSH used was first investigated (Morelle, W., and Michalski, J.C., unpublished results). As expected for a compound expressed in mammalian cells which do not contain the enzymatic machinery for synthesizing the GalNAc-sulfate  
15 signal, no such sulfated signal was found in the product. Neither hybrid nor mannose-rich was observed like in the pituitary stock either. Such glycans are often present in pitTSH because the pituitary extract contains immature forms of the hormone. Rather, only serum-type glycans were identified in recTSH, ranging from biantennary to tetraantennary structure, containing inner fucose and terminated in sialic acid.

20           This glycan pattern is in full agreement with the pattern recently observed for gonadotropins produced in CHO cells (Gervais, A., et al., 2003), indicating that the engineered hormone is appropriately glycosylated with complex glycans by the host system but that some control is nevertheless lacking as the final product is quite different in glycosylation from the native hormone. The putative structure of plasma TSH is also  
25 represented in **Figure 1D**.

          It is well established that mammalian cells of non-pituitary origin can provide a serum-type glycosylation and thus had the potentiality to contain the various changes in glycan structure known to occur in the hormone upon secretion in blood and metabolic clearance as  
30 summarized in Figures 1A-1D. Since it has been previously reported that circulating TSH was highly sialylated and enriched in multiantennary glycans (Papandreou, M.J., et al., 1993), the Inventors therefore hypothesized that this compound might be a good candidate to further engineer mimicks of plasma and disease-related TSH.

Briefly, MALDI-TOF mass spectra were recorded on a Voyager DE-RP (Applied Biosystems, CA, USA), in a positive ion linear mode with a delayed extraction. A saturated solution of matrix was prepared by diluting 10 mg of 3,5-dimethoxy-4-hydroxycinnamic (sinapinic acid) in 500  $\mu$ l of 0.1% trifluoroacetic acid in water and acetonitrile (40/60, V/V).  
5 0.7-1  $\mu$ l of the sample solution was applied to a stainless steel sample plate for MALDI-MS, then 0.7  $\mu$ l of the matrix solution was added and the mixture was allowed to dry at room temperature. Mass calibration was done on a standard horse apomyoglobin solution using its monocharged ion  $[M+H]^+$  at 16951.56 and its double charged ion  $[M+2H]^{2+}/2$  at 8476.28. Mass spectra were then treated by a Gaussian smoothing with a filter width at 19 points.

10 It is reminded that the intensity of the signals (height of the peaks) is poorly related to the quantity of each species and that essentially qualitative values on molecular size of the entities can be interpreted.

As shown in **Figure 14A**, both TSH subunits have been estimated separately using free pitTSH subunits. The  $\alpha$  subunit appeared highly heterogeneous (12.6-14.6 kDa) because it  
15 contains 2 N-glycans while the  $\beta$ -subunit was resolved as 5 main species ranging from 14.6 kDa to 15.3 kDa in size. In contrast, all subunit species appeared of increased molecular weight in the recombinant product (**Figure 14B**), suggesting profound changes in glycosylation in both subunits since these two compounds share the same peptide sequence. In addition, recTSH microheterogeneity was definitely augmented as a result of increased  
20 sialic acid content because treatment with neuraminidase shifted and simplified the profile of both subunits to half a dozen of entities for the asialo  $\alpha$ -subunit (13.4-13.9 kDa) and asialo  $\beta$ -subunit (14.8-15.9 kDa) as shown in **Figure 14C**. Enzymatic resialylation of recTSH (see hereafter) with an engineered  $\alpha$ 2,6 sialyltransferase reproduced the original pattern (**Figure 14D**), indicating that sialic acid (approx. 300 Da per residue) has been transferred virtually  
25 onto both asialo subunits (**Figures 14C and 14D**).

Since the glycans of recTSH cover a wide array of structure totally different from those of the pituitary stock, the glycoforms onto which they are present can be regarded as putative markers of altered glycosylation. Accordingly, the whole recTSH preparation could  
30 be used to assess to what extent changes in glycan structure affect antibody recognition. The Inventors therefore screened a panel of 10 different monoclonal antibodies specific for human TSH ( $\leq 0.2$  % cross-reactivity with gonadotropins) against a highly purified preparation of pitTSH and recTSH. Antibodies specific for TSH were commonly elicited from a pituitary

preparation and selected to recognize this hormone in blood samples with high specificity i.e with virtually no cross-reactivity with gonadotropins or free alpha subunits. Earlier on, two preparations of recTSH were reported to compete with pitTSH for antibodies directed against pituitary TSH (Kashiwai, T., *et al.*, 1991) indicating that distinct preparations of TSH may indeed share cross-reactivity.

As shown in **Table I**, the antibodies could be classified into three groups, depending on their binding to recTSH to a similar (group A), different (group B) or lower extent (group C) than pitTSH at half-maximal binding capacity. Most antibodies differentially recognized the two preparations, indicating that they target determinants which are under direct or indirect control of glycosylation in the hormone antigen. Since the glycans found in recTSH are typically representative of serum-type glycoproteins in mammals, none of them are antigenic. It results that mAbs are directed against peptidic regions under the steric control of glycan chains. Similar recognition of both preparations was observed in group A (mAb BC27) indicates that at least the underlying epitope is similarly expressed in both preparations. Interestingly, some antibodies like mAbs S06 and R2 displayed increased recognition of recTSH, suggesting that changes in glycosylation may generate epitope expression in glycoforms which are masked or absent in the pituitary preparation. In contrast, the recombinant product is poorly recognized by group C antibodies (mAbs B3 and OCD1), because their epitopes are poorly displayed in the antigen.

**Table I. Differential screening of anti-TSH antibodies:**

	mAbs	pitTSH	recTSH
<b>Group A</b> "High binding"	BC27	++++	++++
	R1	++++	+++
	S09	++	+++
<b>Group B</b> "Medium binding"	S06	+	+++
	R2	+	+++
	B1	+++	++
	S04	++	++
	B2	+	++
<b>Group C</b> "Low binding"	B3	+	+
	OCD1	+++	+

Since no information is available for any other antigen in the literature as to whether these findings may be of relevance for improving measurement accuracy, the Inventors were prompted to elucidate the number and location of the common epitopes shared by pitTSH and

recTSH which may be useful to design innovative specific assays as the measurand will be clearly identified.

The same panel anti-TSH antibodies were further used to construct different sandwich formats to establish the epitope map of the recombinant hormone. The capture antibody was unmodified while the tracer antibody was biotinylated and the sandwich amplified using the streptavidin-alkaline phosphatase conjugate. All the experiments were carried out at equilibrium in the presence of excess of hormonal ligands. The results were read by measuring the OD at 405 nm. **Figure 2A-C** summarizes the data.

ELISA experiments were carried out as previously described (Canonne, C., et al., 1995). Briefly microtiter plates were coated with monoclonal anti-TSH antibody (1  $\mu$ g) in 100  $\mu$ L PBS (50 mM, pH 7.5) for 2 hr at 37°C. Washings were performed after each step with PBS containing 0.05% Tween 20. Saturation was performed with 2% BSA-PBS. Increasing concentration of either TSH preparations or lectin fractions were incubated in PBS containing 0.1% BSA overnight at 4°C or for shorter periods of time at 37°C as indicated. Bound TSH was detected with the tracer anti-TSH mAb coupled to biotin (100 ng). Amplification was based on the streptavidin-alkalin phosphatase conjugate and p-NPP substrate as in Legaigneur et al. (2001). All the assays were performed in duplicates and the data expressed as a mean of these values.

In **Figure 2A**, OCD1 was found to bind recTSH independently of the others and partially overlap with R2. In contrast (**Figure 2B**), mAb BC27 appeared to bind the same epitope as mAbs B2, R1 and S09. The determinant bound by mAbs S04 and B1 should either similar or in close vicinity (**Figure 2C**) while the binding of B3 overlapped with that of S06 (**Figure 2D**). These data allowed the Inventors to delineate within recTSH, 3 distinct epitopes designed as **I**, **II** and **III** respectively common to both pitTSH and recTSH. The main characteristic feature of these epitopes is that they can be identified by antibodies directed against the natural hormone with high specificity. As shown in **Figure 3**, epitope I is very likely to be the Main Immunogenic Region (MIR) as it is recognized by most antibodies of the panel. Since R2, OCD1 and S06 bound the two TSHs to a different extent, epitopes II and III are likely to exhibit variable expression in the two preparations tested.

The panel of 10 specific monoclonal antibodies was then used to perform a comparative epitope map of pit- and recTSH based on the use of the 36 sandwich formats.

The data are presented in **Figures 15A-15D** and summarized in Figure 15E. In **Figure 15A**, the mAb (OCD1) tracer was found to bind very similarly both antigens independently of the others and partially overlap with mAb (R2). In contrast (**Figure 15B**), mAb (BC27) bound rather weakly both TSHs and shared the same epitope with mAbs (B1), (B2), (R1) and (S09). **Figure 15C** shows that the determinant bound by mAb (S04) should be in close vicinity of that of mAbs (BC27) and (B1). In **Figure 15D**, it can be seen that the binding of mAb (B3) overlapped that of mAb (S06). Of note, the binding capacity of pitTSH could be reduced as much as 50% compared to recTSH, as in assays using mAbs (R1) and (S04) with (S06) mAb as tracer (**Figure 15D**). This indicated that antibodies may display preference for TSH subforms in these preparations.

As summarized in **Figure 15E**, anti-TSH mAbs target 3 main antigenic regions common to both pit- and recTSH, further designed as I, II and III respectively.

Based on these observations, the Inventors therefore decided to construct two novel types of TSH measurements: a first one tentatively aimed at equally measuring forms present in both pit- and recTSHs i.e. independently of changes in their glycosylation pattern. Another one designed as glycosylation-dependent, more likely to measure alteration in the antigen potentially related to a putative onset of a thyroid disorder. To this aim, they therefore designed and tested the all 6 possible assay formats with the 3 epitopes (I, II and III) namely **I/II, II/I, I/III, III/I, II/III, III/II**, based on the calibration with the 2<sup>nd</sup> IRP pitTSH and the 1<sup>st</sup> IRP recTSH. In all instances, the recTSH preparation commercially used in this study was found immunologically similar to the IRP recTSH standard. For clarity and because the 2<sup>nd</sup> IRP pitTSH is most often used in routine measurements, only this calibration has been given in the figures below.

Alternatively region I can be subdivided in regions Ia and Ib, which respectively recognized by pool Ia antibodies and pool Ib antibodies:

- pool Ia antibodies comprise: S04, B1, and BC27, and
- pool Ib antibodies comprise: B2, S09, and R1.

## **Example 2**

### **I-Single parameter modification of the glycosylation pattern of the glycoprotein antigen**

5 The glycosylation pattern of recTSH was then modified, by either altering its sialylation state, its branching state or its fucosylation state.

It was then determined how the above-defined assays behave when they were given to bind the various preparations of TSH differing in glycosylation. The three sets of recTSH glycoforms were designed either by enzymatic reshaping to modify terminal glycosylation, lectin affinity chromatography for potential variation in branching (Con A chromatography) 10 or core fucosylation (Lentil chromatography). A combination of the enzymatic and fractionation procedures addressed simultaneous changes in sialylation and core fucosylation as described for the onset of hypothyroidism.

#### **I.1. Methods**

15 The sialylation state of recTSH was modified by a neuraminidase treatment, which fully desialylated recTSH, followed by a sialyltransferase treatment by an engineered ST6Gal enzyme, to generate a serum-type sialylation of recTSH.

20 An *oversialylated recTSH* was also obtained by simply treating recTSH by the truncated form of a sialyltransferase without prior desialylation.

Briefly, the neuraminidase treatment was carried out as follows. 250 ng of recTSH was added to 250  $\mu$ L neuraminidase buffer (100 mM sodium acetate, 2 mM CaCl<sub>2</sub>, pH 6.5). Aliquots were incubated with or without 5 mU neuraminidase from *Clostridium perfringens* 25 (Type X) at 30°C overnight, under gentle stirring.

The preferred enzyme is a ST6Gal enzyme as no data in the literature showed a total coverage of glycoproteins with  $\alpha$ 2,6 linked sialic acid. Various secreted mutants of improved catalytic efficiency in transferring sialic acid in the  $\alpha$ 2,6 position have been obtained by deleting the N-terminal of hST6GalII to position 89 included and a stable CHO-K1 clone 30 producing the soluble form of the  $\Delta$ 1-35 hST6GalII mutant enzyme has been previously characterized *in vitro* (Legaigneur, P., et al., 2001). Briefly, the cDNA encoding a truncated  $\Delta$ 1-35/89 form of human ST6GalII lacking the transmembrane segment was cloned into the pFLAG expression vector containing the preprotrypsinogen signal peptide. This form was stably transfected in CHO-K1 cells (Chinese Hamster Ovary cells). The CHO-K1/ $\Delta$ 1-35/89

hST6GalI cell line was grown in DMEM with Glutamax-I medium supplemented with 10% inactivated Foetal Calf Serum, fungizone (2.5 µg/mL), gentamycine (50 µg/mL), and geneticin (200 mg/mL) at 37°C in a 5% CO<sub>2</sub> incubator. The cell culture medium was collected after a 72 h period and further concentrated >15-fold by Centriprep centrifugation. Batches were pooled and the soluble enzyme activity was standardized to a standard calibrator preparation (rat liver ST6Gal I) on asialofetuin as described by Legaigneur, P., *et al.* (2001). Under these conditions, concentrated supernatants were estimated to contain 0.06-0.1 mU/µL and aliquots were stored at -20°C until use.

Sialylation of unsialylated recTSH (*asialo-recTSH*) was carried out in 96-wells microtiter plates. Briefly, the truncated form of hST6Gal I (1.2-2 mU) was added to different amounts of recTSH diluted in PBS containing 0.1% BSA, in a cacodylate buffer (50 mM cacodylate, 0.1% BSA, and 0.1% Triton X-100, pH 6.5) containing 0.9 µg CMP-NeuAc and 2 mM MnCl<sub>2</sub> in a final volume of 100 µL, and incubated over a 30 min-4 h period at 37°C. α<sub>2</sub>,6-linked sialic acid was measured by the sialic acid-specific lectin *Sambucus nigra* agglutinin (SNA) coupled to biotin as previously described (Legaigneur, P., *et al.*, 2001). This modified glycoform of recTSH was named *resialylated recTSH*.

The extent of sialylation was followed by MALDI-TOF mass spectrometry analysis. Alternatively, α<sub>2</sub>,6-linked sialic acid was quantitatively measured in individual microtiter wells with 5 ng of the various TSHs by the use of the sialic acid-specific lectin *Sambucus nigra* agglutinin coupled to biotin as previously described (Legaigneur, P., *et al.*, 2001). Streptavidin-alkaline phosphatase conjugate was used to amplify biotinylated SNA binding. Amplified complexes were revealed using p-NPP substrate. All the assays were performed in duplicates and the data are expressed as a mean of these values.

The ConA lectin (concanavalin A) was used to fractionate recTSH according to its branching state. Briefly, 0.5 mL of Con A-Sepharose was poured into a 3 mL disposable column and further equilibrated with 10 mL buffer containing 10 mM Tris-HCl, 150 mM NaCl, and 1 mM MgCl<sub>2</sub>, MnCl<sub>2</sub>, and CaCl<sub>2</sub> (pH 8.0) as described in Papandreou, M-J., *et al.*, 1993. 5 µg of recTSH were loaded onto the column and allowed to interact with the lectin *at least* for 1 h at room temperature. Unbound recTSH was collected by 10 repeated centrifugations with 1 mL column buffer. Weakly bound and firmly bound fractions were collected using the same procedure and the same buffer with 10 mM α-

methylglucopyranoside and with 500 mM  $\alpha$ -methylmannopyranoside, respectively. PBS containing 2% BSA was added to stabilize fractionated material. Finally, recTSH concentration was determined by testing 100  $\mu$ L of each fraction in solide-phase assay.

5           The Lentil lectin was used to fractionate recTSH according to its fucosylation state. The fractionation proceeded essentially as described for the ConA lectin except that the 10 mM  $\alpha$ -methylglucopyranoside elution step was omitted.

Scale up for isolating oversialylated recTSH was carried out under batch conditions. Briefly, lectin gels were equilibrated with twice 5 mL of column buffer. 5-25  $\mu$ g of oversialylated hormone was then mixed with the gel and allowed to interact with the lectin for 3 hr at room temperature under gentle stirring. The batch was then loaded onto the column and fractions collected as described above.

## 15   **I.2. Results**

Since measurements of TSH are routinely performed on plasma samples, it was of crucial importance to assess Ab recognition of TSHs that may mimic the glycoforms circulating in blood under normal and pathological conditions. Since sulfated TSH is short-  
20   lived (Szkudlinski, M.W., *et al.*, 1995) while sialylated proved to be long-lived in the circulation, the behaviour of recTSHs, with a variable extent of sialylation towards the various formats described above, was first investigated.

To provide a sialylated source of recTSH very similar to plasma glycoproteins, the  
25   sialic acid content of the antigen was enzymatically modified by prior treatment by a neuraminidase and/or subsequent addition of  $\alpha$ 2,6-sialic acid by a recombinant sialyltransferase as described above. This glycosidic bond is not present in recTSH which only contains  $\alpha$ 2,3-sialic acid (Morelle, W., and Michalski, J-C., unpublished results). Antibody recognition was investigated by testing five different TSH glycoforms differing in  
30   sialylation: pitTSH, recTSH, asialo-recTSH, the so-called oversialylated-recTSH containing additive  $\alpha$ 2,6-sialic acid in addition to its  $\alpha$ 2,3-sialic acid content, and resialylated recTSH prepared from asialo-recTSH by adding only  $\alpha$ 2,6-linked sialic acid. All these glycoforms were assessed in the 6 formats defined above.

**Figures 4A-E** show the results of the 6 formats applied to IRP pitTSH, IRP recTSH and oversialylated recTSH and **Figures 12A-C**, summarize the plateau charge obtained for IRP pitTSH (**Figure 12A**), IRP recTSH (**Figure 12B**), and oversialylated recTSH (**Figure 12C**) with the various formats. In all formats, the recognition of asialo-recTSH was virtually identical to recTSH and for sake of clarity has not been included in Figure 12.

When these preparations were estimated with an ultrasensitive amino acid assay, no significant difference was observed in estimating the dose-response curve of each standard preparation (data not shown), suggesting that no artefact of protein quantitation has been introduced. 1 mL of diluted albumin (BSA) standards and unknown sample were mixed with 1 mL of the Working Reagent provided by the manufacturer, and incubated at 60°C in a water bath for 1 hr. The Working reagent contains bicinchoninic acid (BCA) as the detection reagent for Cu<sup>+</sup>, which is formed when Cu<sup>++</sup> is reduced by protein in alkaline environment. This water-soluble complex exhibits absorbance at 562nm that is linear with increasing protein concentration. After cooling all tubes to room temperature, OD at 562nm was measured

**Figures 16A-16F** summarize the maximal binding capacity of the various formats, with respect to IRP pitTSH (**Figure 16A**), IRP recTSH (**Figure 16B**), and oversialylated recTSH (**Figure 16C**) and their corresponding EC<sub>50</sub> in **Figures 5D-F** respectively. When pitTSH is considered, a group of 2 assays (III/II and I/II) displayed a binding capacity twice that of the others (**Figure 16A**), indicating that some mAbs fail to several bind pitTSH forms. Since the II-III as well as I-II formats showed variable binding efficiency when the antibodies were alterned, it was concluded that epitope II is likely to be conformational and better targeted by the tracer antibody. When recTSHs were investigated as a function of their extent in sialylation, the overall binding of TSH was increased (**Figures 16B-16C**) confirming that most mAbs exhibit a potential preference for sialylated forms. Turning to the EC<sub>50</sub>, a 2- to 3-fold decrease was observed for recTSH (**Figure 16E**) compared to pitTSH (**Figure 16D**). The half-maximal binding of the assays did not correlate with their binding capacity except for the III/II assay which showed the lowest EC<sub>50</sub> for the largest binding capacity. No further difference was observed as a result of oversialylation (**Figures 16E-16F**). These data indicated that the assays were discriminating TSH subforms as a function of their concentration in the various preparations.

The S06/BC27 pairing (format III/I) displayed an equal binding of TSH glycoforms similar to 2<sup>nd</sup> IRP pitTSH and was thus found sialylation-independent (**Figure 5A**). This finding is in good agreement with the observation that the I-III format exhibited the lowest efficiency in binding sialylated TSHs (**Figures 16C-16D**). Other formats based on tracer antibodies targeting epitope I behaved very similarly indicating that the Main Immunogenic Region (MIR) is not significantly affected by such altered glycosylation. This indicates that these formats bind and estimate glycoforms expressing the same epitope as in the pituitary IRP standard, independently of changes in terminal glycosylation.

In contrast, testing the BC27/OCD1 pairing (format I/II) revealed higher binding of sialylated TSH glycoforms, and thus exhibited a typical sialylation-dependent behaviour (**Figure 5B**). An increased binding with antigen further modified by  $\alpha$ 2,6-sialylation compared to the  $\alpha$ 2,3 linked sialic acid was also evidenced. The presence of  $\alpha$ 2,6-linked sialic acid in oversialylated glycoforms added by the recombinant  $\alpha$ 2,6-sialyltransferase was controlled by SNA binding (**Figure 5C**) and mass spectrometry (data not shown).

To better understand the basis of such an increase in antibody binding, antibody recognition was analyzed as a function of time (**Figure 6A**) and the data obtained with the BC27/OCD1 pairing were confirmed with the tracer antibody *i.e.* that recognition of mAb OCD1 heavily relies on the presence of sialic acid. The contents in  $\alpha$ 2,6-linked sialic acid for the enzymatically engineered glycoforms were also controlled and an enhanced signal after  $\alpha$ 2,6-sialylation (**Figure 6B**) was detected, indicating that both the oversialylated and resialylated TSHs reached virtual completion in sialic acid as previously reported (Legaigneur et al., 2001). This demonstrated that increasing the extent of sialylation in TSH allowed a better recognition of the array of TSH glycoforms: virtually, antibody binding to resialylated TSH is 2-fold that of the pitTSH calibrant at equilibrium. This also suggested that among glycoforms, some lack antibody recognition because epitope II is poorly expressed as a result of a low content in sialic acid.

These experiments demonstrated that using a format equally efficient in binding pitTSH and rectTSH may result to a 100 % lower binding compared to an assay capable to bind sialylated TSH. Since most circulating forms to be measured in blood were previously demonstrated to be enriched in sialic acid, these data therefore strengthen the importance of having a sialylated calibrator for measuring plasma TSH level under most pathophysiological

circumstances. At present, pituitary extracts are most often used for calibrating commercial kits because no plasma TSH can be isolated in sufficient amount from blood. As a result, the current calibrator is not representative of the circulating antigen to be measured. Under these conditions, TSH level is likely to be overestimated as the nature of its glycosylation significantly differs from the pituitary antigen, especially in primary hypothyroidism.

To further investigate what level of glycan heterogeneity may affect TSH immunodetection and possibly deduce what could be the best match between the antibodies and the calibrant, fractions of recTSH, the glycosylation state of which differed, were isolated by affinity chromatography on lectins. This well established chromatography is known to discriminate glycans according to their degree of branching for Con A fractions or their content in inner fucose for the Lentil fractions. Each fraction is supposed to share common structural features but can still contain terminal microheterogeneity. Sialylation does not affect the isolation.

N-glycans are widely considered as possessing inner microheterogeneity as most glycoproteins exist with and without core fucosylated glycans. This modification is believed to be independent of the degree of branching and of terminal glycosylation, although TSHs that bound firmly to ConA also tended to bind firmly to lentil (Miura, Y., et al., 1989). Core fucosylation is largely admitted to increase the hydrophobicity of the core pentasaccharide by modifying the orientation of the  $\alpha$ -1,6 arm and thus the steric occupancy of the whole glycan (Unverzagt, C., et al., 2002). It is also known to increase the metabolic clearance of plasma glycoproteins by liver.

Primary hypothyroid TSH has been reported to have a reduced core fucosylation compared to the euthyroid state (Schaaf, L., et al., 1995). recTSH was therefore fractionated on a lentil column which specifically binds fucosylated glycoproteins and the effect of inner glycan alteration were analyzed in our 6 assays. To closely mimick the situation found in plasma, recTSH was oversialylated before affinity chromatography and the unbound and bound fractions were measured based on assay calibrated with recTSH on a molar basis. Of note, the unbound fraction is highly homogeneous in that the hormone contained unfucosylated glycans at the three N-glycosylation sites.

Lentil-lectin affinity chromatography showed that  $48.4 \pm 3.3$  % ( $\pm$ SD) of recTSH glycoforms contained no fucose residue and  $51.6 \pm 3.3$  % had at least one internal fucose

among the three N-glycans present on the molecule (**Figure 7A** and **Table II**). This allowed us to isolate lentil-unbound (L-UB) fractions (not fucosylated) and lentil-bound (L-B) fractions (with fucose).

**Figure 17** further shows that under equilibrium conditions, the lentil-unbound and -bound fractions displayed distinct immunological behavior when tested simultaneously in the whole combination of assay. The I/III assay estimated a virtually even distribution of TSH (49% UB-51% B) between the two fractions. In contrast, the III/II assay exhibited almost twice this binding for the bound fraction (29% UB-71% B). Since the compound was fully sialylated, it appeared that most sialylated forms are retained on the lentil column. As observed above, such sialylated glycoforms are better recognized when using formats including the recognition of epitope II. In contrast, formats targeting epitope III were less efficient in binding fucosylated TSH, whereas formats binding epitope I had broader recognition. These findings indicated that both epitopes I and III may be differently expressed as a function of the fucose content in TSH.

Plasma TSH in euthyroid subjects and hypothyroid patients has been shown to exhibit a different pattern on Con A chromatography compared to pituitary TSH as a higher content in Con A-UB fraction was observed (Papandreou, M.J., et al., 1993). This finding was interpreted as a higher degree of branching in TSH glycans. To determine if this alteration may affect recognition of TSHs, sialylated recTSH was fractionated by Con A chromatography and the binding distribution of the three fractions was analyzed in the 6 assays at equilibrium.

Alternatively, binding of recTSH to the Con A column was distributed in three fractions: unbound, weakly bound and firmly bound (**Figure 7B** and **Table II**). Most recombinant TSHs were retained on Con A [unbound,  $15.7 \pm 5.9$  % ( $\pm$ SD); weakly bound,  $29.1 \pm 2.9$  %; firmly bound,  $55.2 \pm 7.6$  %]. The three fractions were designed as Con A-Unbound (UB), weakly bound (WB) and firmly bound (FB). As in **Figures 5 and 6**, all assays were calibrated with the 2<sup>nd</sup> IRP pitTSH and 1<sup>st</sup> IRP recTSH standards.

**Figure 18** further shows that the UB, WB and FB fractions were unevenly estimated when tested in parallel in the various assays. When each fraction was quantitated against recTSH on a molar basis, the UB fraction was ranging from 19% to 43%, while the WB fraction was about 10-28% and the FB fractions from 48-61%. Of interest, a mean value of 18-21-61% as estimated with the III/II assay is similar to a 11-37-52% distribution described earlier for primary hypothyroidism (Miura, Y., et al., 1989) while that of 24-28-48%

measured by the I/II assay is in reasonable agreement with the 27-34-38% distribution reported for euthyroid subject (Papandreou, M.J., et al., 1993), indicating that recTSH may satisfactorily reproduce the heterogeneity of circulating TSH. Since TSH circulating in euthyroid patients may display increased sialic acid content, and the one found in hypothyroid patients may combine increased sialylation with decreased fucosylation, it is not surprising that III/II and I/II assays closely approach the distribution obtained with hypothyroid and euthyroid TSH respectively. Indeed epitope II best allows to target sialylated glycoforms and epitope III non fucosylated glycoforms.

10 **Table II. Isolation of recTSH fractions based on lectin chromatography:**

Lectin-chromatography	Fractions	
Lentil	L-UB	48.4 ± 3.3 %
	L-B	51.6 ± 3.3 %
ConA	ConA-UB	15.7 ± 5.9 %
	ConA-WB	29.1 ± 2.9 %
	ConA-FB	55.2 ± 7.6 %

*Results are expressed in % and determined with the S06-BC27 assay.*

To study the influence of inner fucosylation, we compared the behaviour of mAbs with fucosylated and non fucosylated TSHs separated by Lentil chromatography to the whole preparation of recTSH and in format calibrated with IRP pitTSH.

The use of the BC27/OCD1 pairing (format I/II) revealed a binding of L-UB and L-B fractions very similar to the crude preparation and pitTSH standard, in that it poorly recognizes the fucosylated forms (**Figure 8A**). In contrast, S06/S04 pairing (format III/I) displayed not only a higher binding of than the IRP standard with an improved recognition of fucosylated glycoforms (**Figure 8B**). A two-fold difference was observed at the EC<sub>50</sub>, indicating that inner fucosylation increased Ab recognition. It was concluded that this sandwich was not dependent on TSH fucosylation in contrast to the I/II format.

To identify which epitope was fucosylation-dependent, we carried out the kinetics of binding of the capture (mAbs S06) and tracer (mAb S04) antibodies independently. S06 binding was found to display variable binding to the various TSHs upon time whereas mAb S04 showed no discrimination towards the fucose content of TSH glycoforms (**Figure 9**). This allowed us to assign epitope III as being under the control of core fucosylation. It is conceivable that increasing inner fucosylation in TSH may alter expression of this epitope since the content of the recombinant product is high. This also opens the possibility that under

primary hypothyroidism, increasing fucosylation of blood TSH may alter TSH measurements progressively depending on the antibodies used in the assay and results in discordant measurements among kits which contain different combination of Abs.

To identify how antibody recognition may depend on TSH core fucosylation, binding experiments were conducted within shorter periods of time and at low concentration of unmodified recTSHs to avoid a potential interference with the content in sialic acid (**Figures 8A-8B, 9A-9B**). The I/II assay showed no major difference in binding among lentil fractions, recTSH and pitTSH (**Figure 8A**), indicating that in this case, the presence of inner fucose in the analyte does not significantly affect TSH measurement. **Figure 8B** however shows a 3-fold increase in the recognition of the UB lentil fraction over pitTSH in the III/I assay. To determine which of the epitope I or III was responsible for this variation, we carried out kinetics studies at low TSH concentration. As shown in **Figure 9A**, binding of mAb (S06) targeting epitope III exhibited an increased recognition for both lentil fractions compared to pitTSH under limiting concentration of antigen. In contrast, binding of mAb (S04) recognizing epitope I was unaffected (**Figure 9B**). In both instances, optimal binding was reached within 60 min. This indicated that in TSH, expression of epitope I is likely to be independent of core fucosylation. As a result, a decrease in inner TSH glycosylation will not affect the measurement of hormone level as primary hypothyroidism develops provided that mAbs are directed against epitope I. Conversely, recognition of epitope III of non fucosylated recTSH was found to be faster than the fucosylated fraction or any of the total TSHs, indicating a higher affinity of the antibodies. As a result, disease-related TSH may compete with increased secretion of many other altered glycoforms within a short period of time if epitope III were to be targeted by capture antibodies. The measurement may then be overestimated by a factor of 3-5 when using a pituitary calibrator, especially at low level of TSH (**Figure 8B**).

Since plasma TSH was observed to be largely unretained on ConA chromatography compared to pitTSH standard under normal or pathological conditions (Papandreou, M-J., *et al.*, 1993), the Inventors also paid special attention to the binding of antibodies towards TSHs isolated by this lectin.

Like in the experiments described above, the three TSH fractions against all the formats calibrated against the 2<sup>nd</sup> IRP pitTSH were tested. In most instances, the respective distribution among Ubd vs WB vs FB fractions was differentially estimated by the various formats while the total recovery was similar. As shown in **Figures 10A-10D**, no difference in

dose-dependent binding among the 3 TSH fractions could be noticed among 4 formats, with most of them displaying a significant increase in binding capacity compared to the pitTSH standard. It can be concluded that branching per se does not significantly influence the recognition of any of the 3 epitopes. These data nevertheless further support the proposal that a combination of certain antibodies allowed better binding than others depending on the calibrant used.

**Figures 10A-10D** shows that in the absence of resialylation and at equilibrium, there was a major variation in antibody recognition not so much among the three Con A fractions but rather with respect to the pituitary standard (**Figures 10A-10C**) except for the I/III assay which displayed the lowest capacity (**Figure 10D**). Like the I/II (**Figure 10A**) and the III/I (**Figure 10C**) assays, the III/II assay exhibited an increased recognition of Con A fractions of recTSH but no major difference in binding capacity among assays (**Figure 10B**). The FB fraction appeared best recognized in all assays. The glycan structure of this so-called FB material was thus analyzed by mass spectrometry to get an insight of this abundant fraction but no peculiar glycan structure could be attributed to this fraction.

Since the Con A-UB fraction may be of physiological relevance, the Inventors focused on this fraction in spite of a limited amount which precluded structural characterization. Preliminary work revealed that ConA-UB fraction of sialylated recTSH is also unbound on a Lentil column. This fraction should presumably contain highly complex nonfucosylated glycans at all N-glycosylation sites and is likely to combine the most dramatic changes in epitope expression. Indeed a significant increase of epitope III expression may very well occur as the fucose content is diminished while the epitope I expression is unchanged and epitope II even gained as the content in sialic acid increases. The estimation of ConA-UB fraction by most formats appeared quite variable. At the EC50, such TSH glycoforms may be overestimated by a factor of 8 by the III/I assay, by a factor of 6 with a III/II assay or by a factor of 5 by the I/II assay when they are measured against pitTSH. It is worth noticing once again, that the amount of unknown entities may be dramatically overestimated within the low concentration range.

As a result, it is proposed that the choice of epitope for the capture antibody should be associated with the use of the calibrant, both being critical for the final measurement of TSH (**Figures 12A-12C**). Then, the choice of a given tracer antibody will further improve the overall quantitation depending whether or not it recognizes an epitope under the control of sialylation. Basically 3 groups of formats can be designed:

**1-Formats I/III or III/I:**

The MIR determinant can be used to capture glycoforms sharing the highest similarity with pitTSH (glycoprotein 1). Because this latter is recognized by most of the antibodies commercially available, epitope I offers a variety of possibilities for commercial use to construct formats which are poorly sensitive to changes in glycosylation. Epitope III (format I/III) is acceptable to be used as tracer epitope in that it fully accommodates changes in fucosylation. This sandwich format will be best calibrated with pitTSH and other unsialylated/poorly sialylated and poorly fucosylated glycoforms of pit/recTSH like Lentil-unbound fractions.

**2-Formats I/II:**

Epitope II (format I/II) allows a definite better recognition of TSHs enriched in sialic acid. It should be used in conjunction with a sialylated calibrant to allow satisfactory estimation, especially at low levels of TSH.

When associated to a capture antibody directed against epitope I, the calibrant should also contain a low content in core fucosylation to approach a quantitative measurement of the antigen. As a result the best calibrant would be the Lentil-unbound fraction of over/resialylated recTSH.

**3-Formats III/II:**

Selecting antibodies targeting epitope III definitely permits to capture the highest amount of glycoforms independently of the nature of the calibrant (pitTSH vs. recTSH) and of the extent of sialylation of the sample measured (recTSH vs. oversialylated recTSH). Using epitope II further increases the maximal binding capacity of the assay. The best estimation will be provided by using a highly sialylated and highly fucosylated calibrant like the Lentil-bound fraction of over/resialylated recTSH.

Since the expression of the 3 relevant epitopes are each under a differential control of TSH glycosylation state, the above proposal is also intended to solve the discordances observed so far among TSH measurements. To allow satisfactory detection of altered TSH enriched in sialic acid and fucose, epitope III will be better used as capture epitope to optimize binding of fucosylated TSHs upon the onset of hypothyroidism. Epitope II as tracer to allow the highest detection of all the forms for which the extent of sialylation has been increased as

the disease develops. Since the alteration of TSH glycosylation in the whole panel of thyroid disorders is still unknown, this format appears also best suited for the diagnostic and the follow up of these diseases.

### 5 Example 3

#### **Multiple parameter modification of the glycosylation pattern**

So as to obtain glycoforms of recTSH for which two or more of the glycosylation parameters are altered, successive modifications of recTSH were carried out by enzymatic  
10 treatment and/or chromatographic fractionation, according to the methods already described.

In a first instance, oversialylation of recTSH followed by ConA chromatography was performed. The results of the various immunoassays formats according to the invention are shown in Figure 11A.

In another instance, oversialylation of recTSH followed by lentil chromatography was  
15 performed. The results obtained for the various immunoassays formats according to the invention are shown in Figure 11B.

In still another instance, sialylation was first performed on recTSH, followed by a ConA chromatography and then by a lentil chromatography of the ConA unbound fraction. Our results showed that the oversialylated ConA unbound fraction is not retained on lentil.  
20

### Example 4

#### **Selection of antibodies directed against a recombinant TSH**

Any of the recombinant TSH preparation or fraction used in the preceding examples  
25 can be administered to mice in order to produce several monoclonal antibodies specific for TSH according to the general procedure described by Kohler, G., and Milstein, C. (1975).

The anti-TSH monoclonal antibodies can then be screened against any of the glycoforms of any recTSH fractions or preparations described in Examples 2 and 3.

Several antibodies are obtained which preferentially recognize either the  
30 oversialylated or the resialylated glycoforms of recTSH as compared to recTSH itself. Those antibodies are useful for the detection of the putative forms of TSH circulating in blood of hypothyroid patients, patients with non-thyroid illnesses, or TRH-treated patients. Such forms contain highly branched and sialylated chains as reported in Papandreou *et al.*, 1993. Occasionally, as for hypothyroid TSH, they also have altered core fucosylation. Such disease-

related glycoforms are best measured with the III/II format calibrated with enzymatically resialylated recTSH fractions. In contrast, low or subnormal TSH levels, as in euthyroid subjects, are better estimated by glycosylation-independent formats calibrated with either pitTSH or recTSH such as the I/III or III/I format. Preferably, the I/II format may show a lower sensitivity threshold, provided that binding properties of the antibodies and calibration with pit/recTSH are further optimized better suited for daily use of these assays which may be quite far from equilibrium.

### Example 5

#### 10 **Immunological comparison of pituitary, recombinant, and plasma TSH**

The epitopic cartography of plasma TSH was performed on serum samples of hypothyroid individuals (plasma concentration above 100 mIU/L) by using the above mentioned formats corresponding to epitopes Ia, Ib, II and III. Thus, 45 antibody combinations were used (5 tracer antibodies and 9 capture antibodies).

A quantity of antigen close to the EC50 was used (2 ng) so as to operate at half the binding capacity of the assay formats. The value retained for antigen binding was that reached at equilibrium.

A comparative epitopic cartography of pitTSH and recTSH was also performed in the same conditions, with rabbit serum or hyperthyroid serum so as to disregard the effect of the serum in plasma TSH samples.

The results are shown in **Figures 19A-19O**.

Overall, these results are coherent with the results obtained in the previous Examples with saturating concentrations of the antigen, that is a higher binding capacity of recTSH with respect to pitTSH.

Plasma TSH shows an overall binding stronger than that of pit TSH and equivalent (epitope I and III) or identical (epitope II) to that of recTSH. Moreover, antibody R2 binds more strongly to plasma TSH than to pit TSH and recTSH.

Of note, formats with tracer antibodies directed against epitope II have the highest binding capacity. This is not surprising given that this epitope is sialylation-dependant and that hypothyroid conditions are characterized by an increase in sialic acid levels. Thus, this epitope is of great importance for detecting hypothyroidism onset.

The results are summed up in **Figures 20A-20C**. It clearly appears from **Figure 20C** that recTSH presents an antibody binding profile close to that of plasma TSH. Thus, under the

experimental conditions described herein, recTSH should prove a better TSH immunologic assays calibrant than the currently used pitTSH.

5 However, an even better calibrant than recTSH should be provided for clinical assays, since such assays are performed rapidly, i.e. before equilibrium is reached. Thus, preliminary results by the inventors indicate that several glycoforms of recTSH have enhanced antibody binding properties as compared to recTSH itself. Such glycoforms notably encompass oversialylated or resialylated glycoforms of recTSH and/or defucosylated glycoforms of recTSH.

Furthermore, the following formats seem most adapted for plasma TSH assays:

10 Ia/Ib, Ia/II, Ib/II, Ia/III, Ib/III and III/II.

## REFERENCES

- 5 Spencer, C.A., Takeuchi, M., Kazarosyan, M., MacKenzie, F., Beckett, G.J., and Wilkinson, E. (1995) Interlaboratory/intermethods differences in functional sensitivity of immunometric assays of thyrotropin (TSH) and impact on variability of measurements of subnormal concentrations of TSH. *Clin. Chem.* 41 (3): 367-374.
- 10 Spencer, C.A., and Demers, L.M. (2003) Laboratory medicine practice guidelines: Laboratory support for the diagnosis and monitoring of thyroid disease. *Clin. Endocrinol.(Oxf)*. 58 (2): 138-140.
- 15 Zerfaoui, M. and Ronin, C. (1996) Glycosylation is the structural basis for changes in polymorphism and immunoreactivity of pituitary glycoprotein hormones. *Eur. J. Clin. Chem. Clin. Biochem.* 34:749-753.
- Methods on Glycoconjugates: a laboratory manual (1995) Ed: André Verbert, Harwood Academic Publishers.
- 20 Benkirane, M.M., Bon, D., Costagliola, S., Paolucci, F., Darbouret, B., Prince, P., and Carayon, P. (1987) Monoclonal antibody mapping of the antigenic surface of human thyrotropin and its subunits. *Endocrinology*. 121 (3): 1171-1177.
- 25 Grossmann, M., Szkudlinski, M.W., Tropea, J.E., Bishop, L.A., Thotakura, N.R., Schofield, P.R., and Weintraub, B.D. (1995) Expression of human thyrotropin in cell lines with different glycosylation patterns combined with mutagenesis of specific glycosylation sites. Characterization of a novel role for the oligosaccharides in the in vitro and in vivo bioactivity. *J. Biol. Chem.* 270 (49): 29378-29385.
- 30 Canonne, C., Papandreou, M-J., Medri, G., Verrier, B., and Ronin, C. (1995) Biological and immunochemical characterization of recombinant human thyrotropin. *Glycobiology*. 5 (5): 473-481.
- 35 Papandreou, M-J., Persani, L., Asteria, C., Ronin, C. and Beck-Peccoz, P. (1993) Variable carbohydrate structures of circulating thyrotropin as studied by lectin affinity chromatography in different clinical conditions. *J. Clin. Endocrinol. Metab.* 77 (2): 393-398.
- 40 Gervais, A., Hammel, Y.A., Pelloux, S., Lepage, P., Baer, G., Carte, N., Sorokine, O., Strub, J.M., Koerner, R., Leize, E., and Van Dorsselaer, A. (2003) Glycosylation of human recombinant gonadotrophins: characterization and batch-to-batch consistency. *Glycobiology*. 13 (3): 179-189.
- 45 Kashiwai, T., Ichihara, K., Endo, Y., Tamaki, H., Amino, N., and Miyai, K. (1991) Immunological and biological characteristics of recombinant human thyrotropin. *J. Immunol. Methods*. 143: 25-30.
- Legaigneur, P., Breton, C., El Battari, A., Guillemot, J-C., Auge, C., Malissard, M., Berger, E.G., and Ronin, C. (2001) Exploring the acceptor substrate recognition of the human beta-galactoside alpha 2,6-sialyltransferase. *J. Biol. Chem.* 276 (24): 21608-21617.

- Szkudlinski, M.W., Thotakura, N.R., Tropea, J.E., Grossmann, M., and Weintraub, B.D. (1995) Asparagine-linked oligosaccharide structures determine clearance and organ distribution of pituitary and recombinant thyrotropin. *Endocrinology*. 136 (8): 3325-3330.
- 5 Kohler, G., and Milstein, C. (1975) Continuous cultures of fused-cells secreting antibody of predefined specificity. *Nature*. 256: 495-497.
- 10 Price A, Burgin C, Catch I, and Cruise M. Functional sensitivity and recovery of thyroid-stimulating hormone. *Clin Chem*. 2001; 47(11): 2067.
- Rafferty B and Gaines Das R. Comparison of pituitary and recombinant human Thyroid-Stimulating Hormone (rhTSH) in a multicenter collaborative study: establishment of the first World Health Organization Reference Reagent for rhTSH. *Clin Chem* 1999; 45(12): 2207-2215.
- 15 Miura Y, Perkel VS, Papenberg KA, Johnson MJ, and Magner JA. Concanavalin-A, lentil, and ricin lectin affinity binding characteristics of human thyrotropin: differences in the sialylation of thyrotropin in sera of euthyroid, primary, and central hypothyroid patients. *J Clin Endocrinol Metab* 1989; 69(5): 985-995.
- 20 Unverzagt C, Andre S, Seifert J, Kojima S, Fink C, Srikrishna G, Freeze H, Kayser K, and Gabius HJ. Structure-activity profiles of complex biantennary glycans with core fucosylation and with/without additional alpha 2,3/alpha 2,6 sialylation: synthesis of neoglycoproteins and their properties in lectin assays, cell binding, and organ uptake. *J Med Chem* 2002; 45(2): 478-491.
- 25 Schaaf L, Trojan J, Helton TE, Usadel KH, and Magner JA. Serum thyrotropin (TSH) heterogeneity in euthyroid subjects and patients with subclinical hypothyroidism: the core fucose content of TSH-releasing hormone-released TSH is altered, but not the net charge of TSH. *J Endocrinol*. 1995;144(3): 561-571.
- 30

## CLAIMS

1. The use of the assessment of the binding between

- antibodies elicited against a first glycoprotein, and

5 - at least one glycoform of a second glycoprotein, said second glycoprotein being itself a glycoform of the first protein,

wherein said glycoform of the second glycoprotein is selected from a group of glycoforms of the second glycoprotein, each glycoform of said group corresponding to a determined glycosylation state defined by a determined sialylation state, and/or a determined branching

10 state, and/or a determined fucosylation state, provided that said glycosylation state is not uniquely defined by a substantially unsialylated state,

for the screening of glycoform specific antibodies directed against a given glycoform of the second glycoprotein.

15 2. A process for screening glycoform specific antibodies among antibodies elicited against a first glycoprotein, comprising a step of determination of the binding between

- antibodies elicited against a first glycoprotein, and

- at least one glycoform of a second glycoprotein, said second glycoprotein being itself a glycoform of the first protein,

20 wherein said glycoform of the second glycoprotein is selected from a group of glycoforms of the second glycoprotein, each glycoform of said group corresponding to a determined glycosylation state defined by a determined sialylation state, and/or a determined branching state, and/or a determined fucosylation state, provided that said glycosylation state is not uniquely defined by a substantially unsialylated state,

25 to recover antibodies liable to bind to at least one given glycoform of the second glycoprotein.

3. A process according to claim 2, wherein the glycosylation state of the glycoform of the second glycoprotein presents at least one of the following criteria:

- it is essentially more sialylated than said second glycoprotein, or

30 - it is essentially less sialylated than said second glycoprotein, or

- it is essentially more branched than said second glycoprotein, or

- it is essentially less branched than said second glycoprotein, or

- it is essentially more fucosylated than said second glycoprotein, or

- it is essentially less fucosylated than said second glycoprotein.

4. A process according to claim 2 or 3, wherein the binding between at least one of the antibodies elicited against the first glycoprotein and each of the glycoforms of the second glycoprotein which are respectively:

- 5
- essentially more sialylated than said second glycoprotein,
  - essentially less sialylated than said second glycoprotein,
  - essentially more branched than said second glycoprotein,
  - essentially less branched than said second glycoprotein,
  - essentially more fucosylated than said second glycoprotein, and
  - 10 - essentially less fucosylated than said second glycoprotein,
- is determined.

5. A process according to claim 2 or 3, wherein the glycosylation state of the glycoform of the second glycoprotein presents at least two of the following criteria:

- 15
- it is essentially more sialylated or less sialylated than said second glycoprotein,
  - it is essentially more branched or less branched than said second glycoprotein,
  - it is essentially more fucosylated or less fucosylated than said second glycoprotein.

6. A process according to claim 5, wherein the glycosylation state of the glycoform of the second glycoprotein presents one of the following criteria:

- 20
- it is essentially more sialylated and more fucosylated than said second glycoprotein, or
  - it is essentially more sialylated and less fucosylated than said second glycoprotein, or
  - it is essentially more sialylated and more branched than said second glycoprotein, or
  - it is essentially more sialylated and less branched than said second glycoprotein, or
  - 25 - it is essentially less sialylated and more fucosylated than said second glycoprotein, or
  - it is essentially less sialylated and less fucosylated than said second glycoprotein, or
  - it is essentially less sialylated and more branched than said second glycoprotein, or
  - it is essentially less sialylated and less branched than said second glycoprotein, or
  - it is essentially more branched and more fucosylated than said second glycoprotein, or
  - 30 - it is essentially more branched and less fucosylated than said second glycoprotein, or
  - it is essentially less branched and more fucosylated than said second glycoprotein, or
  - it is essentially less branched and less fucosylated than said second glycoprotein.

7. A process according to claim 2, 3 or 5, wherein the glycosylation state of the glycoform of the second glycoprotein presents three of the following criteria:

- it is essentially more sialylated or less sialylated than said second glycoprotein,
- it is essentially more branched or less branched than said second glycoprotein,
- 5 - it is essentially more fucosylated or less fucosylated than said second glycoprotein.

8. A process according to claim 7, wherein the glycosylation state of the glycoform of the second glycoprotein presents one of the following criteria:

10 - it is essentially more sialylated, more branched and more fucosylated than said second glycoprotein,

- it is essentially more sialylated, more branched and less fucosylated than said second glycoprotein,

- it is essentially more sialylated, less branched and more fucosylated than said second glycoprotein,

15 - it is essentially more sialylated, less branched and less fucosylated than said second glycoprotein,

- it is essentially less sialylated, more branched and more fucosylated than said second glycoprotein,

20 - it is essentially less sialylated, more branched and less fucosylated than said second glycoprotein,

- it is essentially less sialylated, less branched and more fucosylated than said second glycoprotein,

- it is essentially less sialylated, less branched and less fucosylated than said second glycoprotein.

25 9. A process according to any of claims 2 to 8, wherein the antibodies elicited against the first glycoprotein bind to the second glycoprotein with an affinity equal to or higher than the binding affinity of said antibodies to the first glycoprotein.

30 10. A process according to any of claims 2 to 9, wherein at least one lectin fractionation of the second glycoprotein is performed to obtain a glycoform of the second glycoprotein of a determined glycosylation state.

11. A process according to claim 10, wherein the lectin is selected from the group comprising mannose-specific lectins, such as the ConA or Lentil lectins, fucose-specific lectins, such as the Ulex lectin, galactose-specific lectins, such as ricin, or sialic acid-specific lectins, such as the limulin or Sambucus nigra lectin.

5

12. A process according to any of claims 2 to 11, wherein at least one enzymatic modification of the second glycoprotein is performed to obtain a glycoform of the second glycoprotein of a determined glycosylation state.

10 13. A process according to claim 12, wherein the enzymatic modification is carried out by an enzyme selected from the group comprising a glycosidase, in particular a neuraminidase or a fucosidase, or a glycosyltransferase, in particular a sialyl transferase or a fucosyl transferase.

14. A process according to any of claims 2 to 13, wherein a glycoform of the second  
15 glycoprotein of a determined glycosylation state is obtained by a combination of at least one enzymatic modification of the second glycoprotein and/or of at least one lectin fractionation.

15. A process according to any of claims 2 to 14, wherein a less sialylated glycoform of the  
20 second glycoprotein as compared to the second glycoprotein is obtained by neuraminidase treatment of said second glycoprotein.

16. A process according to any of claims 2 to 15, wherein a more sialylated glycoform of the  
25 second glycoprotein as compared to the second glycoprotein is obtained by sialyltransferase treatment of said second glycoprotein or by neuraminidase treatment followed by sialyltransferase treatment of said second glycoprotein.

17. A process according to any of claims 13 to 16, wherein the sialyltransferase is a  $\alpha$ -2,6  
30 sialyltransferase, in particular a ST6GalII sialyltransferase, more particularly a N-terminal shortened ST6GalII sialyltransferase deleted of at most its first 99 residues, such as represented by SEQ ID NO: 1.

18. A process according to any of claims 2 to 17, wherein a less fucosylated glycoform of the  
second glycoprotein as compared to the second glycoprotein is obtained by lentil fractionation  
of the second glycoprotein by collecting the fraction which does not bind to lentil and a more

fucosylated glycoform of the second glycoprotein as compared to the second glycoprotein is obtained by collecting the fraction which binds to lentil.

5 19. A process according to any of claims 2 to 18, wherein a ConA fractionation of the second glycoprotein is performed by collecting three fractions, A, B, and C, the binding of which to ConA is such that,

- C binds to ConA more strongly than B does, and

- B binds to ConA more strongly than A does,

10 the branching state of a given fraction being essentially different from the branching state of the other two fractions.

20. A process according to any of claims 2 to 19, wherein, in a preliminary step, the antibodies to be screened are classified in pools, each pool being characterized in that two antibodies selected from a same pool can not bind to the same glycoprotein at the same time.

15

21. A process according to any of claims 2 to 20, wherein in a first step, said first step preceding the preliminary step of claim 20, it is checked that the antibodies elicited against the first glycoprotein bind to the second glycoprotein.

20 22. A process according to any of claims 2 to 21, wherein the binding of the antibodies to the first glycoprotein, to the second glycoprotein and to the glycoforms of the second glycoproteins is determined by using immunoassays, in particular immunoassay formats using an amplification system for detection, such as an ELISA.

25 23. A process according to claim 22, wherein the immunoassay is a sandwich immunoassay, in particular a sandwich ELISA test, comprising the following steps:

- fixing a capture antibody, selected from a pool such as defined in claim 20, onto a support,

- contacting a glycoprotein, corresponding to the first glycoprotein, to the second glycoprotein or to the glycoforms of the second glycoprotein, to said capture antibody, to form, if adequate,

30 a capture antibody-glycoprotein binary complex,

- contacting a tracer antibody, selected from a pool such as defined in claim 20, provided said pool is different from the one used for the selection of said capture antibody, to said capture antibody-glycoprotein binary complex, to form, if adequate, a capture antibody-glycoprotein-tracer antibody ternary complex,

- detecting the tracer antibody for measuring the number of ternary complexes.

24. A process according to any of claims 2 to 23, wherein the first glycoprotein and the second glycoprotein are similar.

5

25. A process according to any of claims 2 to 23, wherein the first glycoprotein and the second glycoprotein originate from different natural tissues and/or fluids.

10 26. A process according to any of claims 2 to 23, wherein the first glycoprotein originates from a natural tissue and the second glycoprotein is a recombinant protein.

27. A process according to any of claims 2 to 26, wherein the first glycoprotein is a N-linked glycoprotein, such as TSH, in particular pituitary TSH, LH, FSH, or placental hCG.

15 28. A process according to any claim 26 or 27, wherein the first glycoprotein is pituitary or blood human TSH and the second glycoprotein is a recombinant human TSH, in particular a recombinant human TSH produced by mammalian cells.

20 29. The use of a glycosylation-specific antibody as screened by the process according to any of claims 2 to 28, for the binding or the purification of given glycoforms of the second glycoprotein.

25 30. A process for the preparation of a glycoform of a recombinant human TSH produced by mammalian cells, characterized in that said recombinant human TSH is sialylated by a  $\alpha$ -2,6 sialyltransferase, in particular a human ST6GalI sialyltransferase, more particularly a N-terminal shortened human ST6GalI sialyltransferase deleted of at most its first 99 residues, such as represented by SEQ ID NO: 1, to yield an oversialylated glycoform of the recombinant TSH bearing  $\alpha$ 2,3 and  $\alpha$ 2,6 sialyl moieties

30 31. A process according to claim 30, wherein the recombinant human TSH is first treated by a neuraminidase, in particular a *Clostridium perfringens* or a *Vibrio cholerae* neuraminidase, to give a substantially unsialylated TSH, and then submitted to sialylation, to yield a resialylated glycoform of the recombinant TSH bearing essentially only  $\alpha$ 2,6 sialyl moieties.

32. A process for the preparation of a glycoform of a recombinant human TSH produced by mammalian cells, characterized in that said recombinant human TSH is submitted to a lentil fractionation, to give a lentil unbound fraction and a lentil bound fraction, the lentil unbound fraction being retained to yield a substantially unfucosylated glycoform of the recombinant TSH and the lentil bound fraction being retained to yield a glycoform which is substantially more fucosylated than said recombinant TSH.
33. A process according to claim 32, wherein:
- the recombinant human TSH is submitted to neuraminidase treatment, in particular a *Clostridium perfringens* or a *Vibrio cholerae* neuraminidase, prior to lentil fractionation, or
  - the lentil bound fraction or the lentil unbound fraction of the recombinant human TSH is submitted to neuraminidase treatment,
- to yield a substantially unsialylated substantially unfucosylated glycoform of the recombinant human TSH or a glycoform of the recombinant human TSH which is substantially unsialylated and substantially more fucosylated than said recombinant human TSH.
34. A process according to any of claims 30 to 32, wherein
- the recombinant human TSH is submitted to sialylation to give an oversialylated glycoform of the recombinant human TSH, or both to neuraminidase treatment and to sialylation to give a resialylated glycoform of the recombinant human TSH, prior to lentil fractionation of said glycoform, or
  - the lentil unbound fraction or the lentil bound fraction of the recombinant human TSH is submitted to sialylation, or sequentially to both neuraminidase treatment and sialylation,
- to yield a substantially unfucosylated oversialylated or resialylated glycoform of the recombinant human TSH or a glycoform of the recombinant human TSH which is oversialylated or resialylated and substantially more fucosylated than said recombinant human TSH.
35. A glycoform of recombinant human TSH such as obtainable according to any of claims 30 to 34.
36. A glycoform of a recombinant human TSH produced by mammalian cells which comprises from about 70% to about 100%  $\alpha$ 2,3 and  $\alpha$ 2,6 sialyl groups, in particular from

about 70% to about 85 %  $\alpha$ 2,3 sialyl groups and from about 15% to about 30%  $\alpha$ 2,6 sialyl groups.

5 37. A glycoform of a recombinant human TSH produced by mammalian cells which comprises from about 70% to about 100 %  $\alpha$ 2,6 sialyl groups.

38. A glycoform of a recombinant human TSH produced by mammalian cells which comprises essentially no fucose.

10 39. A glycoform of a recombinant human TSH produced by mammalian cells which comprises from about 30% to about 100% fucose.

40. A glycoform of a recombinant human TSH produced by mammalian cells according to claim 38, which comprises essentially no fucose and no sialyl groups.

15

41. A glycoform of a recombinant human TSH produced by mammalian cells according to claim 39, which comprises essentially no sialyl groups and from about 30% to about 100% fucose.

20 42. A glycoform of a recombinant human TSH produced by mammalian cells according to claims 36 and 38, which comprises from about 70% to about 100%  $\alpha$ 2,3 sialyl and  $\alpha$ 2,6 sialyl groups, in particular from about 70% to about 85 %  $\alpha$ 2,3 sialyl groups and from about 15% to about 30%  $\alpha$ 2,6 sialyl groups, and essentially no fucose.

25 43. A glycoform of a recombinant human TSH produced by mammalian cells according to claims 37 and 38, which comprises from about 70% to about 100 %  $\alpha$ 2,6 sialyl groups and essentially no fucose.

30 44. A glycoform of a recombinant human TSH produced by mammalian cells according to claims 36 and 39, which comprises from about 70% to about 100%  $\alpha$ 2,3 sialyl and  $\alpha$ 2,6 sialyl groups, in particular from about 70% to about 85 %  $\alpha$ 2,3 sialyl groups and from about 15% to about 30%  $\alpha$ 2,6 sialyl groups and from about 30% to about 100% fucose.

45. A glycoform of a recombinant human TSH produced by mammalian cells according to claims 37 and 39, which comprises from about 70% to about 100 %  $\alpha$ 2,6 sialyl groups and from about 30% to about 100% fucose

5 46. A kit for assaying specific glycoforms of a first glycoprotein, characterized in that it comprises at least one antibody such as screened according to the process of any of claims 2 to 28,

10 47. A kit according to claim 46, for assaying TSH in a biological sample, characterized in that it comprises:

- at least one capture-antibody selected from pools Ia, Ib, or III,
- at least a tracer-antibody selected from pools Ib, II, or III,

provided that the capture-antibody and the tracer-antibody do not belong to the same pool, wherein:

- 15
- pool Ia is defined as being the pool of antibodies which can not bind to TSH once antibody BC27, S04 , B1 has already been bound to it,
  - pool Ib is defined as being the pool of antibodies which can not bind to TSH once antibody B2,R1 or S06 has already been bound to it,
  - pool II is defined as being the pool of antibodies which can not bind to TSH once

20

  - pool III is defined as being the pool of antibodies which can not bind to TSH once antibody B3 or S06 has already been bound to it.

48. A kit according to claim 46 or 47, characterized in that it comprises:

- 25
- a capture-antibody selected from pool Ia and a tracer antibody selected from pool Ib, or
  - a capture-antibody selected from pool Ia and a tracer antibody selected from pool II, or
  - a capture-antibody selected from pool Ib and a tracer antibody selected from pool II, or

30

  - a capture-antibody selected from pool Ia and a tracer antibody selected from pool III, or
  - a capture-antibody selected from pool Ib and a tracer antibody selected from pool III, or
  - a capture-antibody selected from pool III and a tracer antibody selected from pool II.

49. A kit according to claim 47 or 48, characterized in that it further comprises a calibrant selected from the list comprising:

5 pituitary human TSH, recombinant human TSH produced by mammalian cells, a glycoform of recombinant human TSH produced by mammalian cells which substantially less sialylated than said recombinant human TSH, a glycoform of recombinant human TSH produced by mammalian cells which is substantially more sialylated and/or less fucosylated than said recombinant human TSH, and a glycoform of recombinant human TSH according to any of claims 33 to 36.

10

50. The use of a glycoprotein selected from the list comprising:

a glycoform of recombinant human TSH produced by mammalian cells which is substantially less sialylated than said recombinant human TSH, a glycoform of recombinant human TSH produced by mammalian cells which is substantially more sialylated and/or less fucosylated than said recombinant human TSH, and a glycoform of recombinant human TSH according to any of claims 35 to 45

15

for calibrating TSH immunoassays.

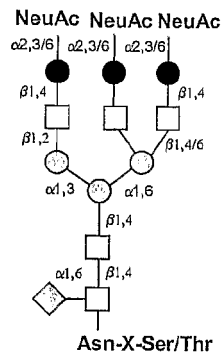

Figure 1A

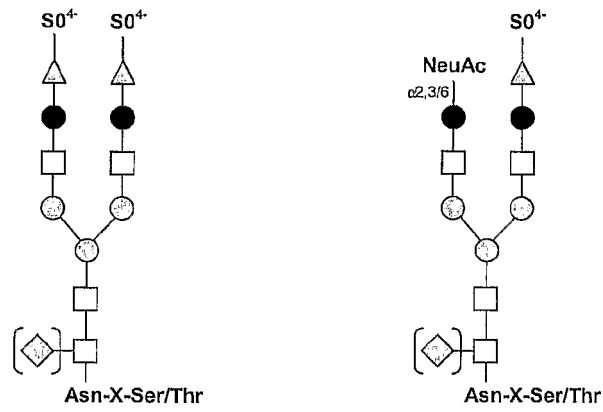

Figure 1B

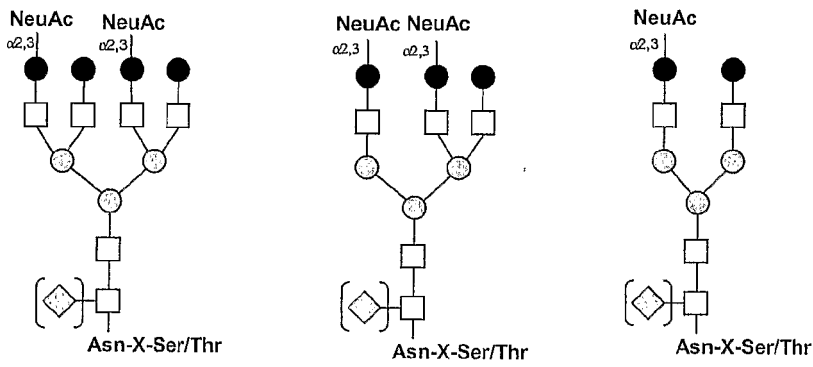

Figure 1C

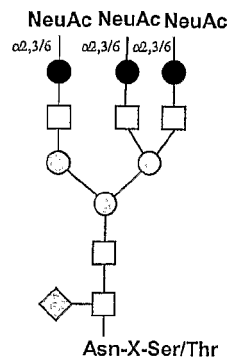

Figure 1D

2/22

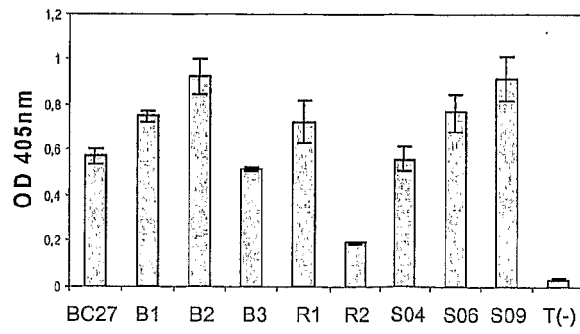

Figure 2A

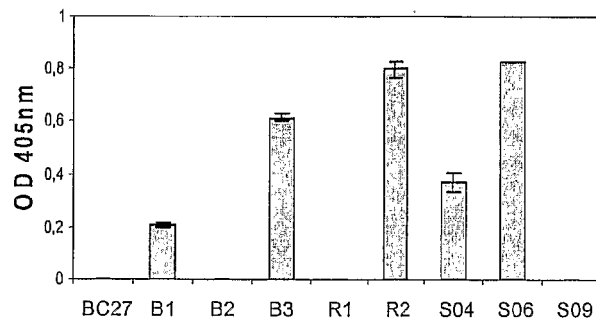

Figure 2B

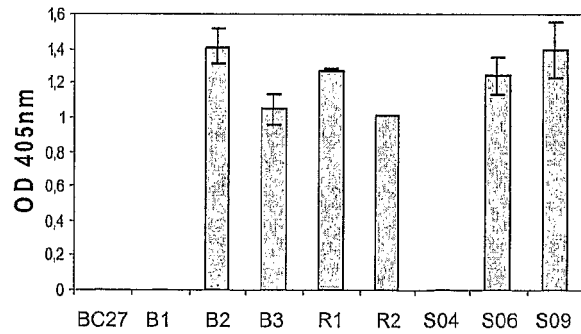

Figure 2C

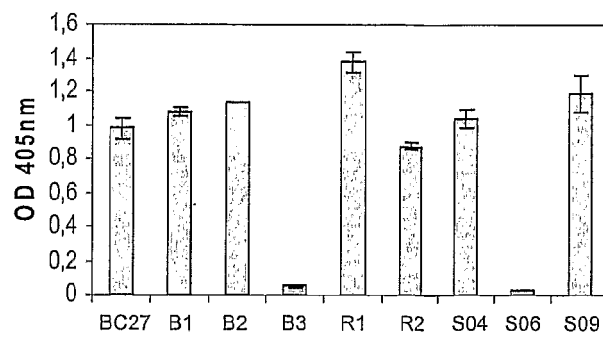

Figure 2D

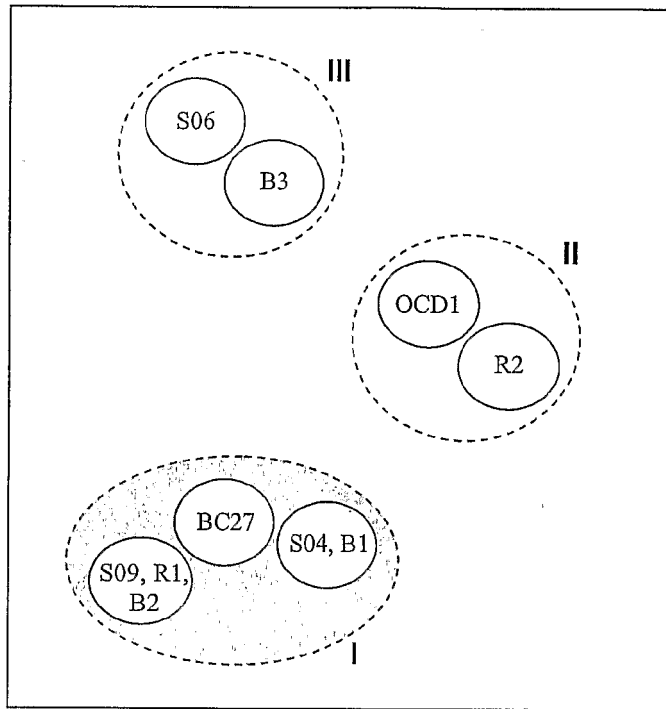

Figure 3

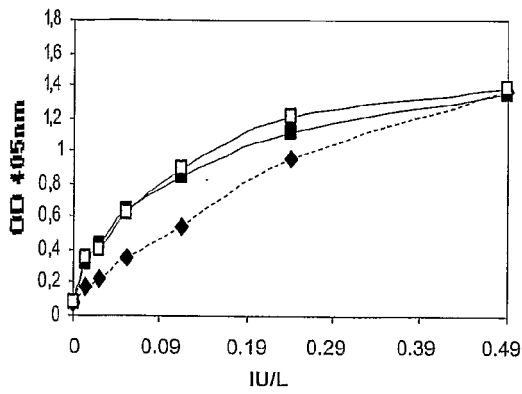

Figure 4A

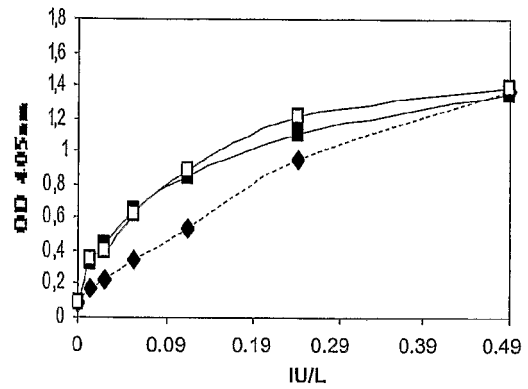

Figure 4B

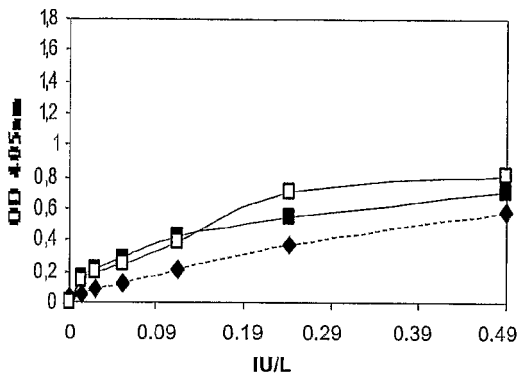

Figure 4C

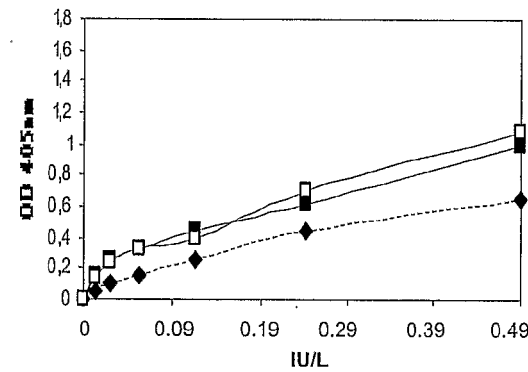

Figure 4D

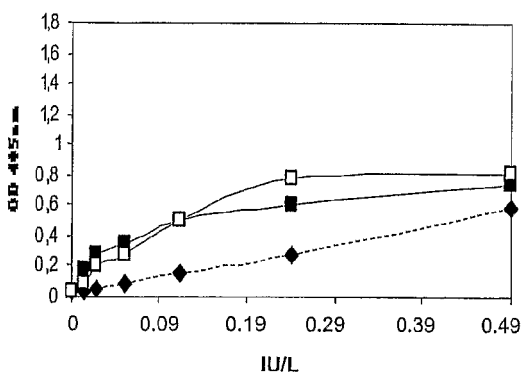

Figure 4E

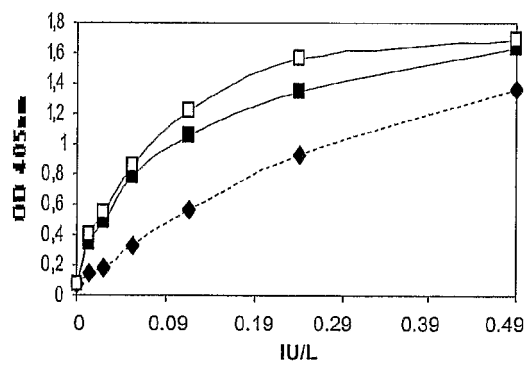

Figure 4F

5/22

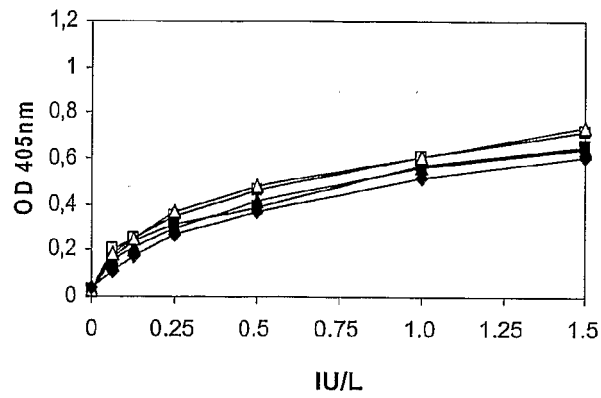

Figure 5A

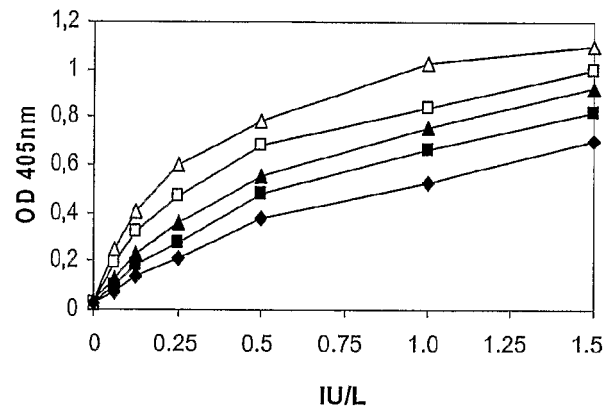

Figure 5B

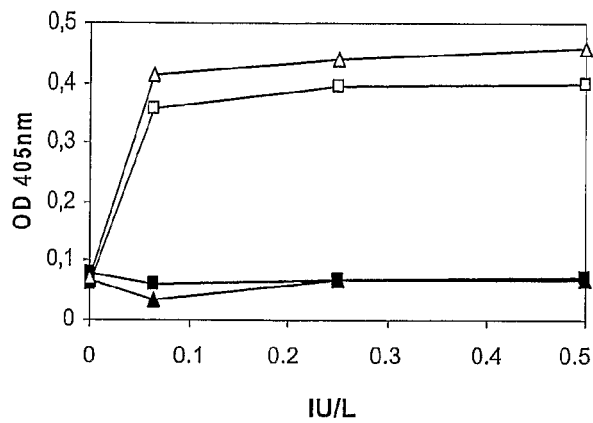

Figure 5C

6/22

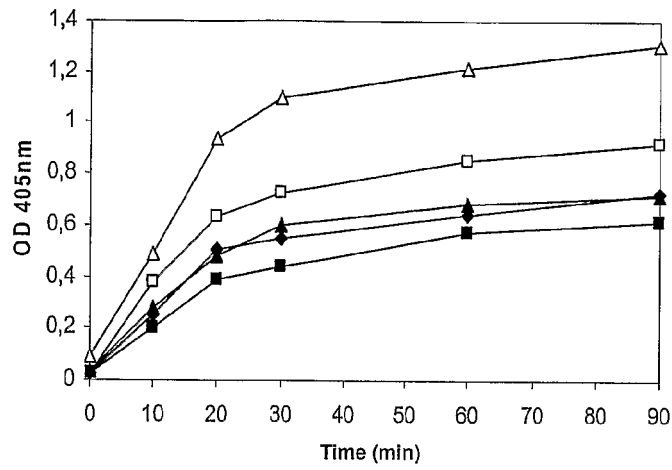

Figure 6A

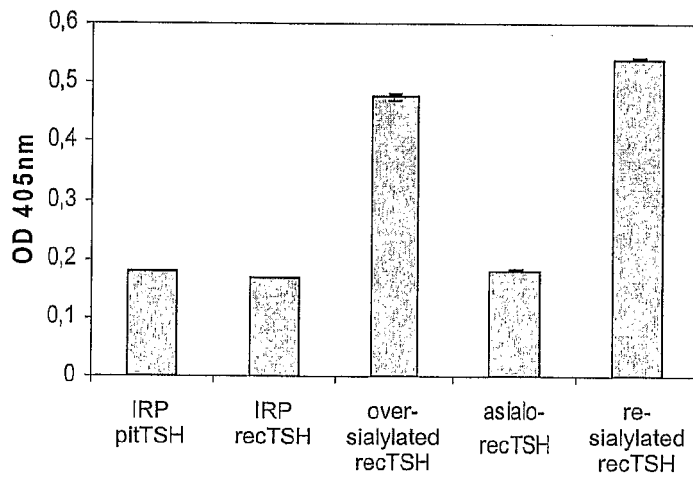

Figure 6B

7/22

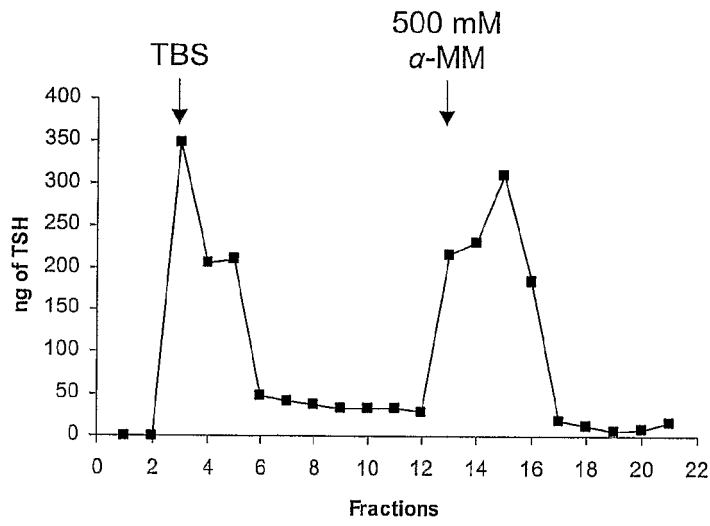

Figure 7A

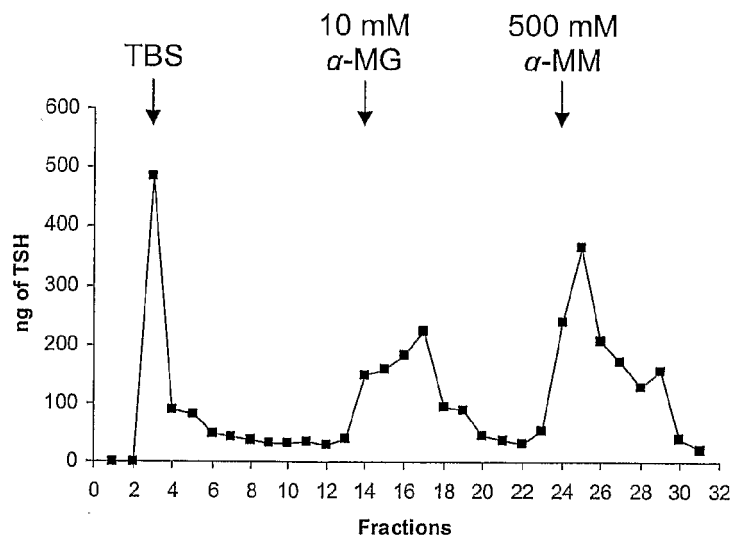

Figure 7B

8/22

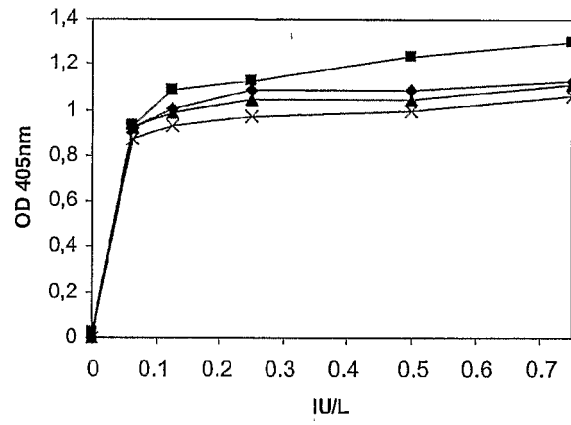

Figure 8A

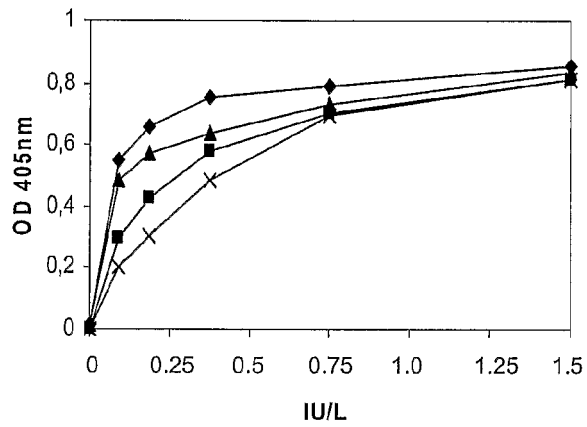

Figure 8B

9/22

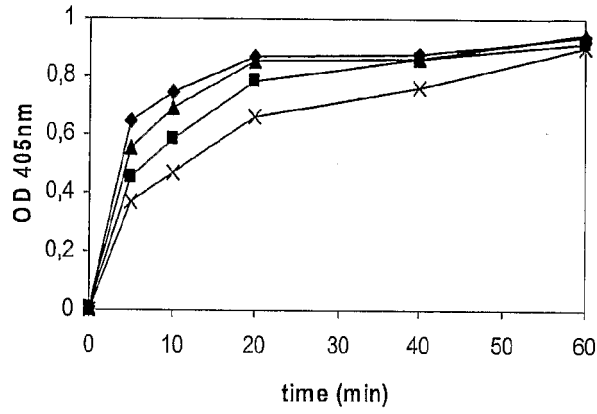

Figure 9A

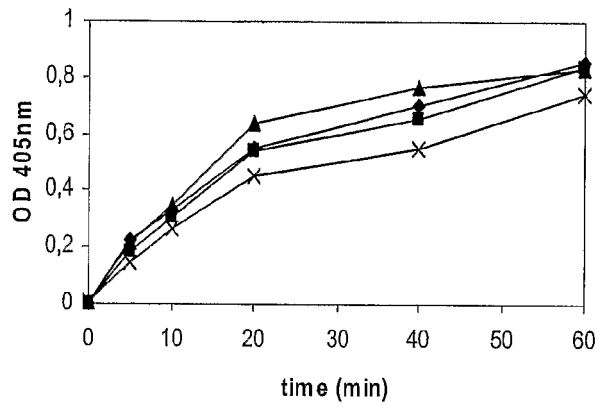

Figure 9B

10/22

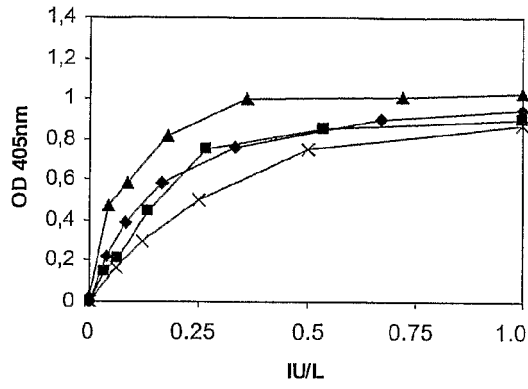

Figure 10A

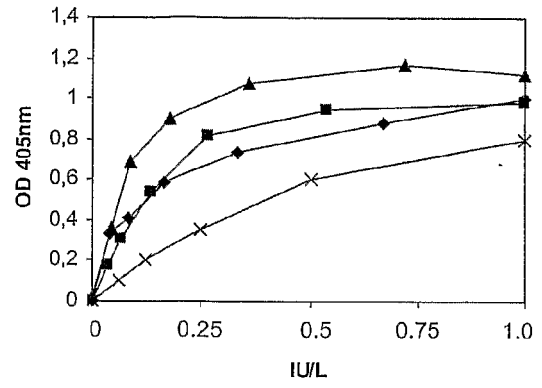

Figure 10B

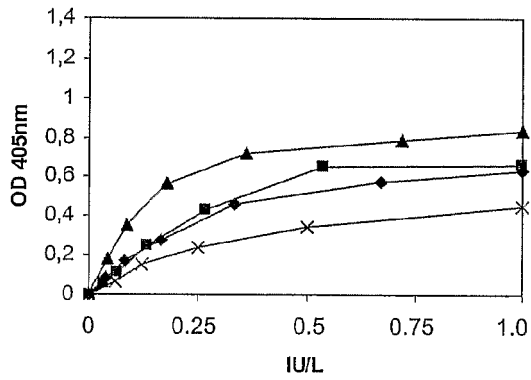

Figure 10C

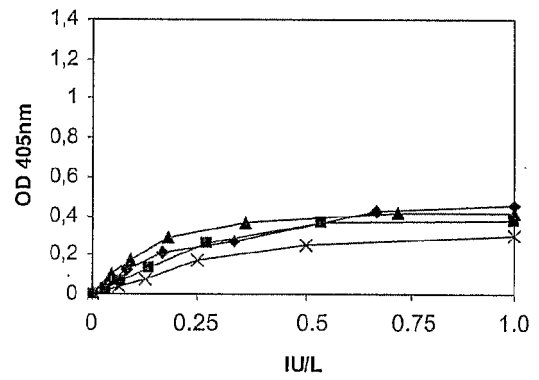

Figure 10D

11/22

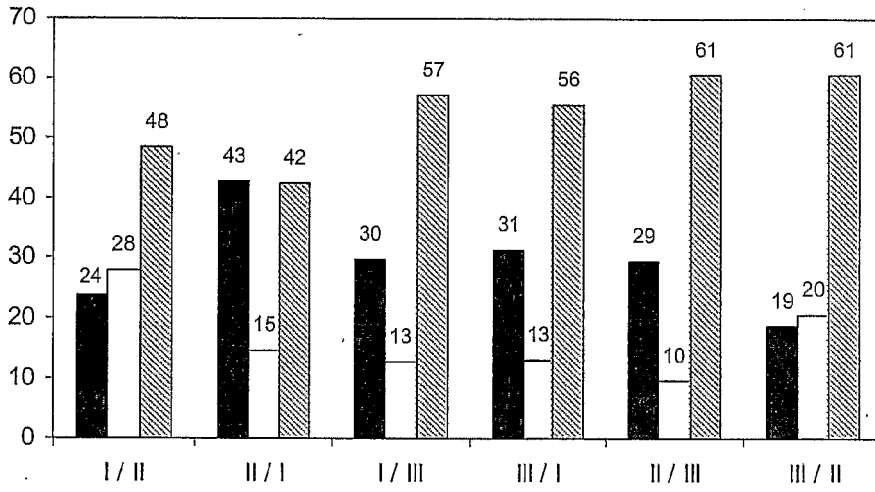

Figure 11A

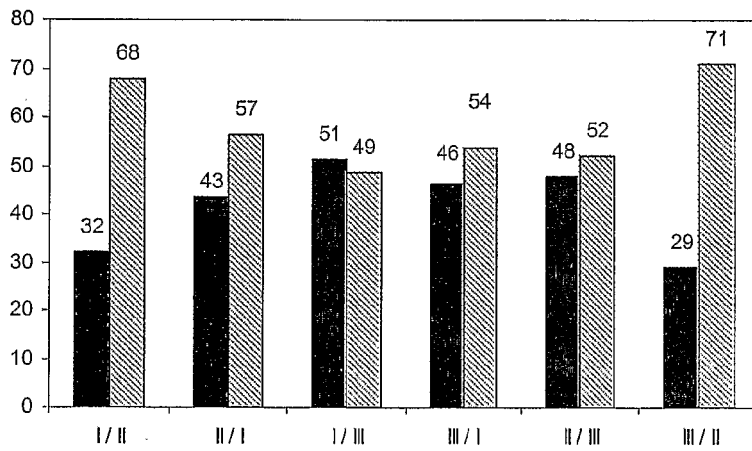

Figure 11B

12/22

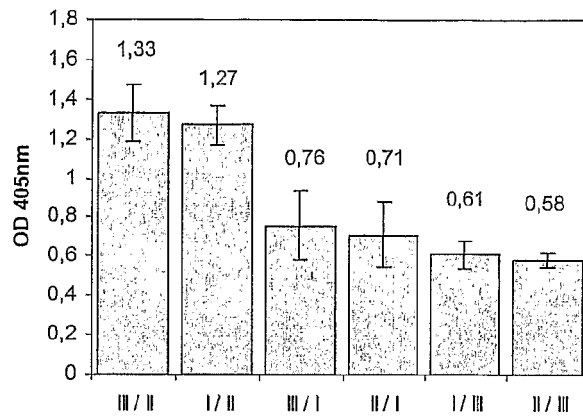

Figure 12A

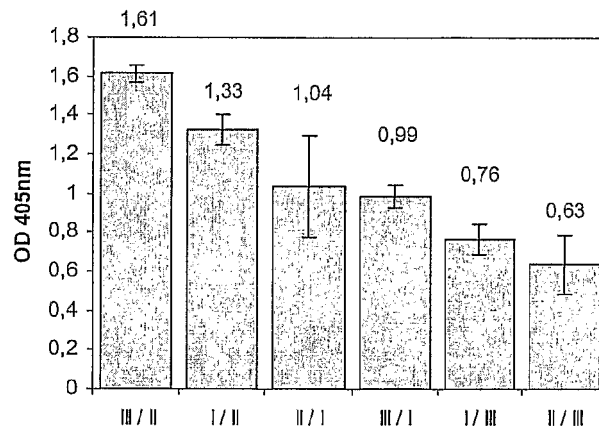

Figure 12B

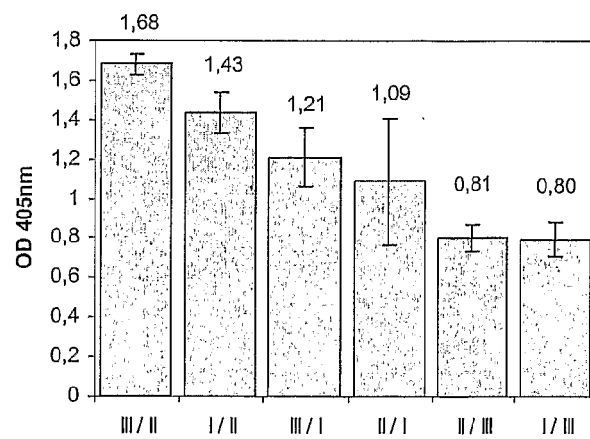

Figure 12C

13/22

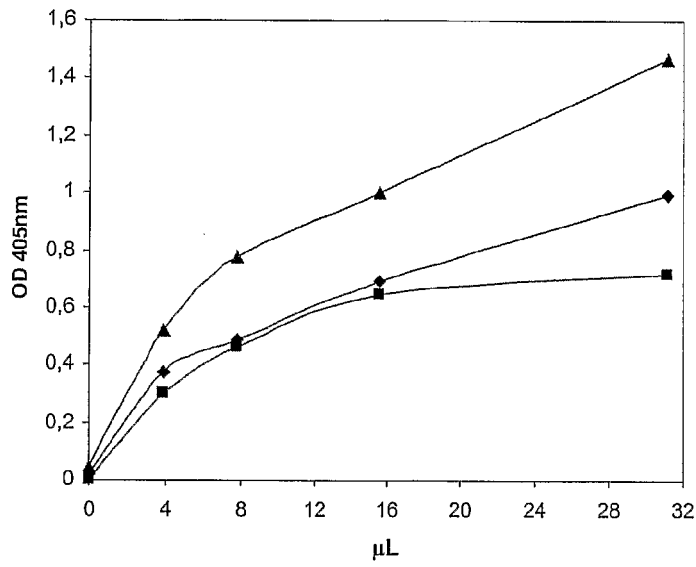

Figure 13A

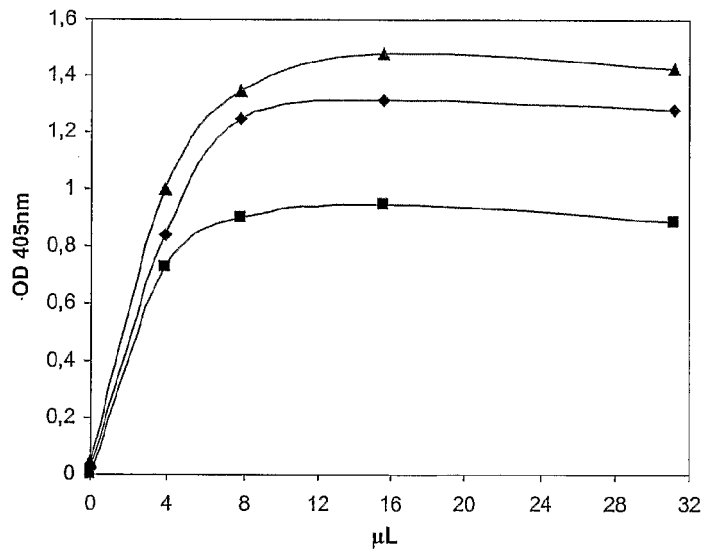

Figure 13B

14/22

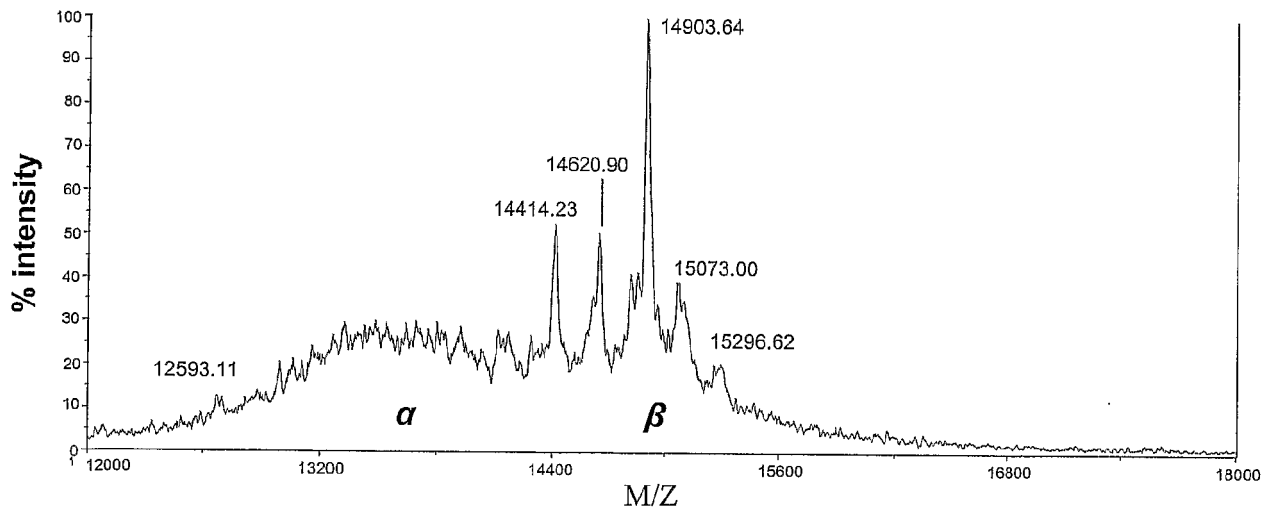

Figure 14A

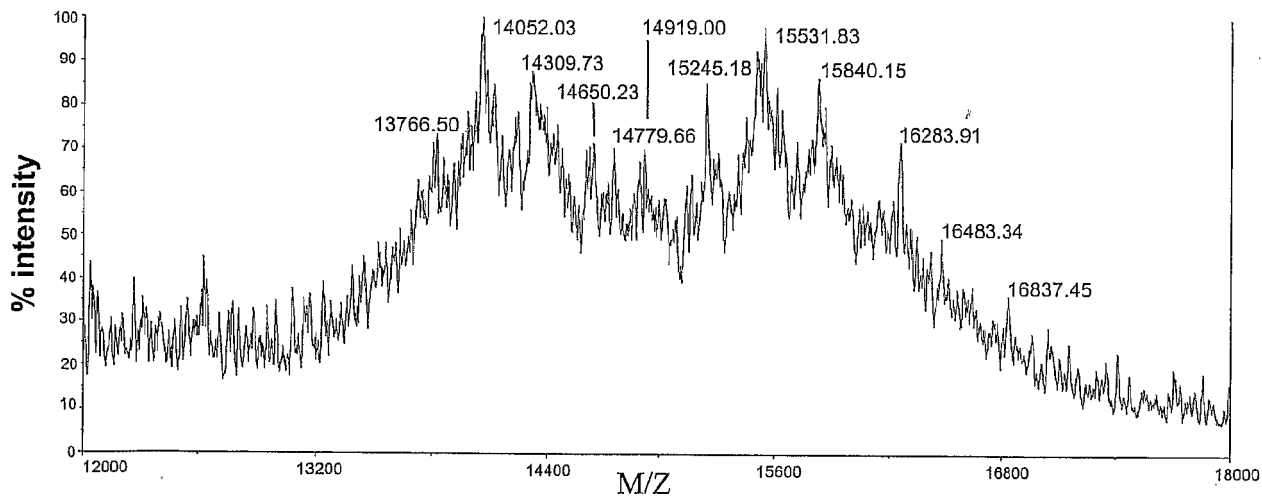

Figure 14B

15/22

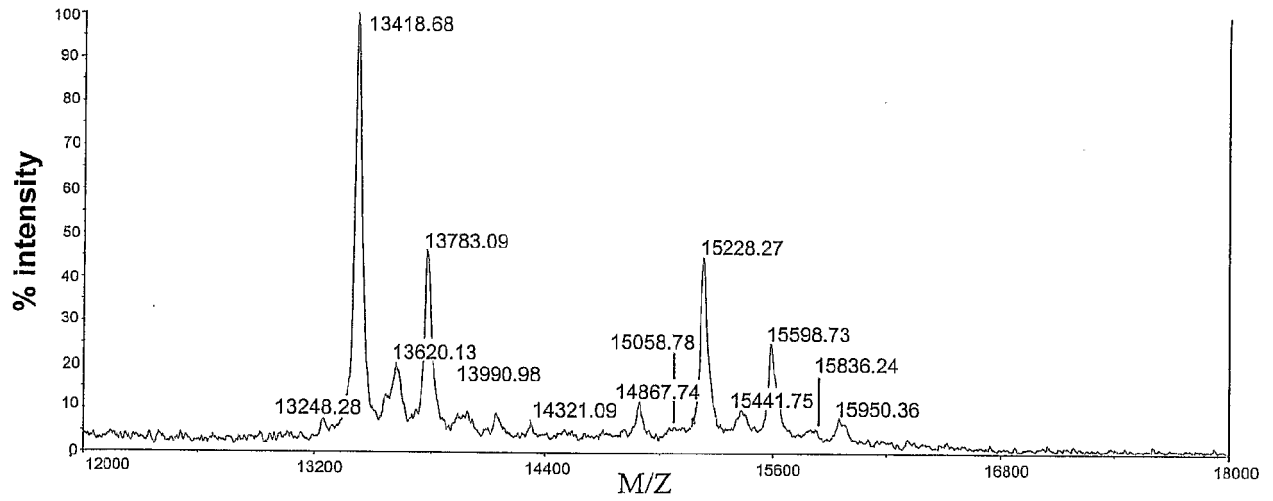

Figure 14C

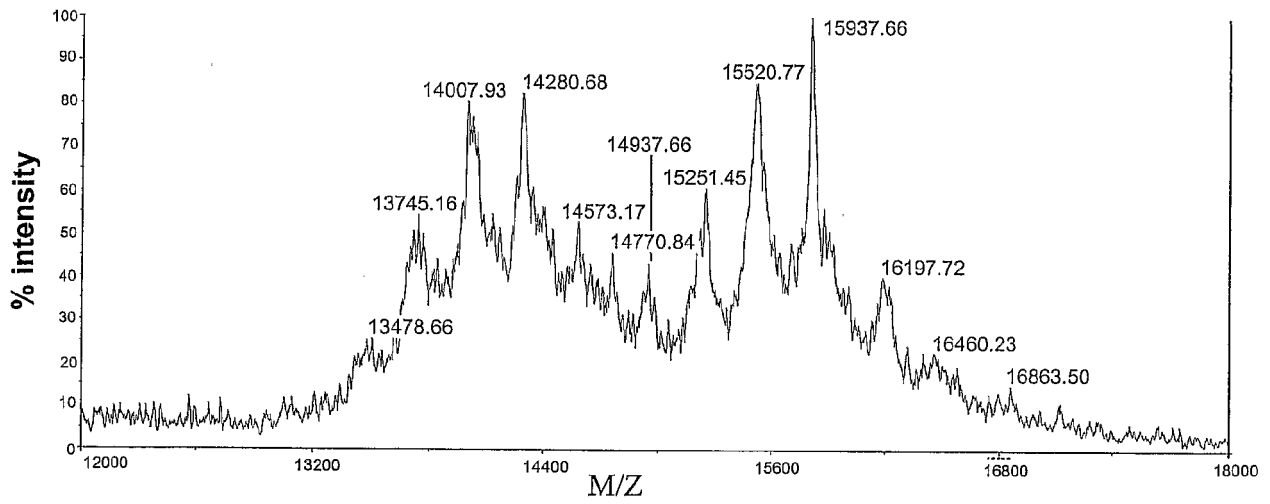

Figure 14D

16/22

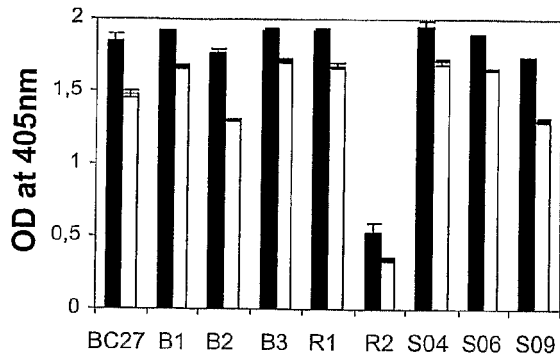

Figure 15A

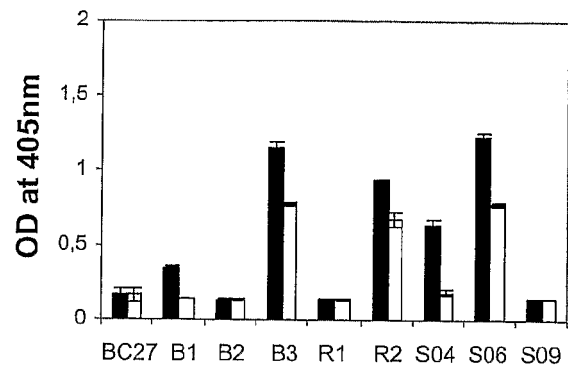

Figure 15B

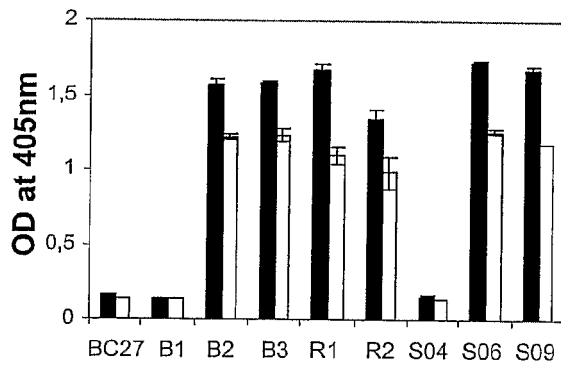

Figure 15C

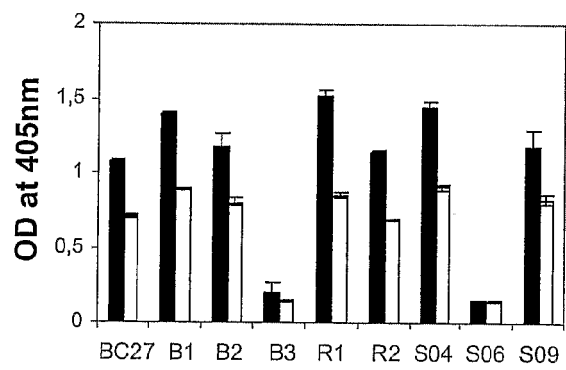

Figure 15D

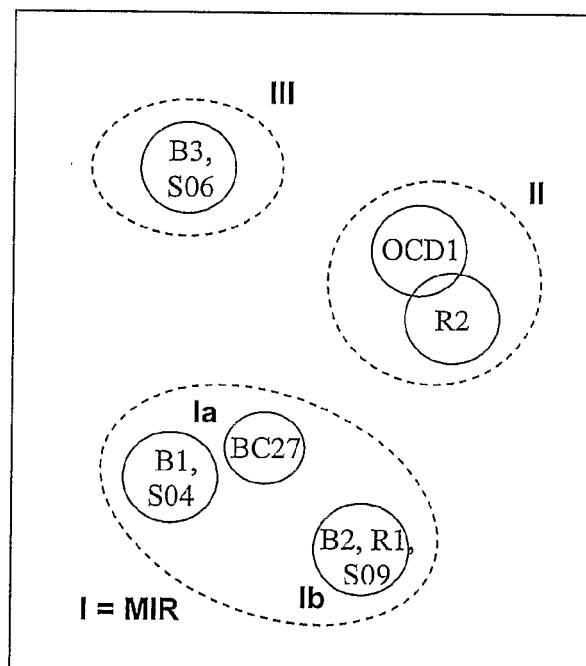

Figure 15E

17/22

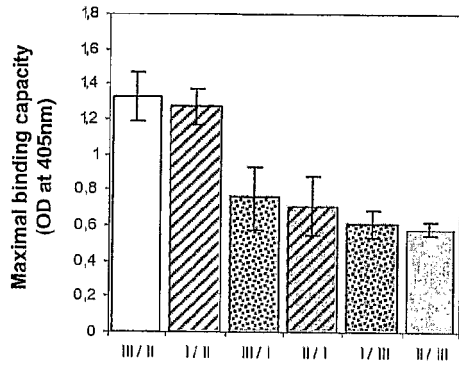

Figure 16A

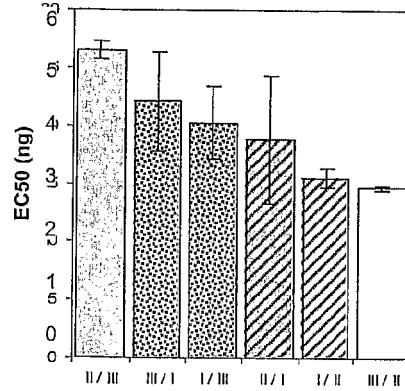

Figure 16D

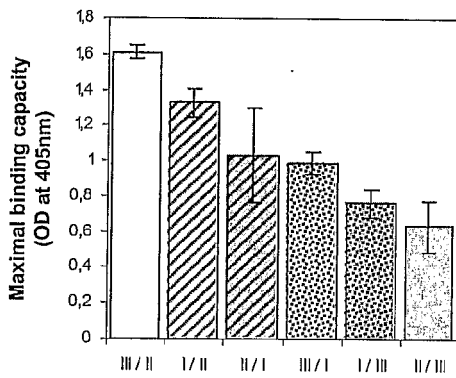

Figure 16B

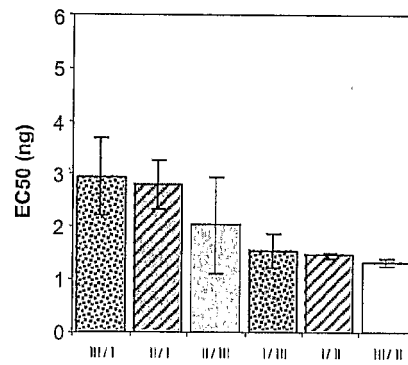

Figure 16E

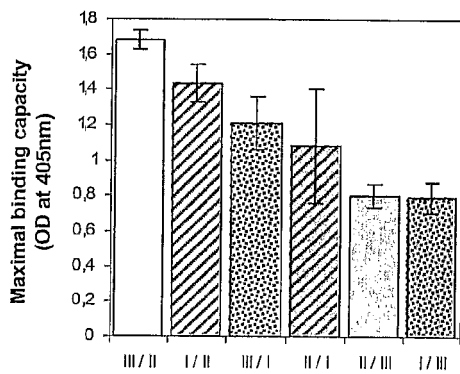

Figure 16C

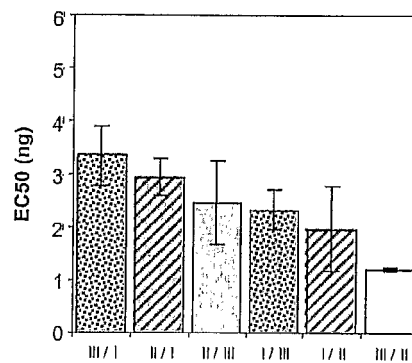

Figure 16F

18/22

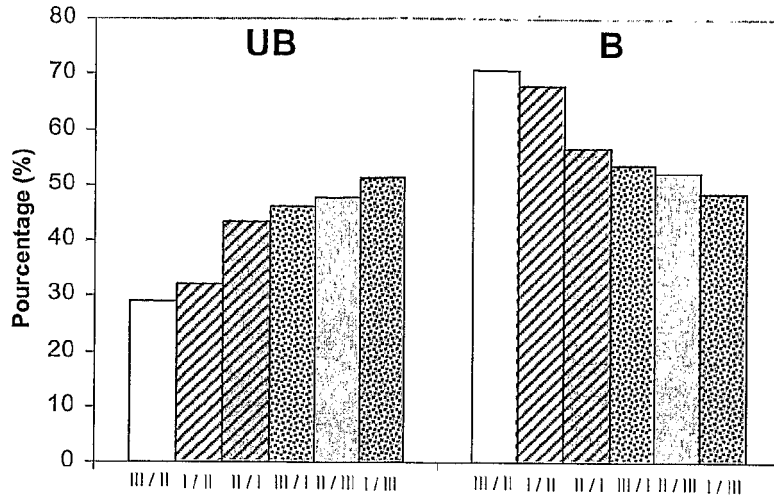

Figure 17

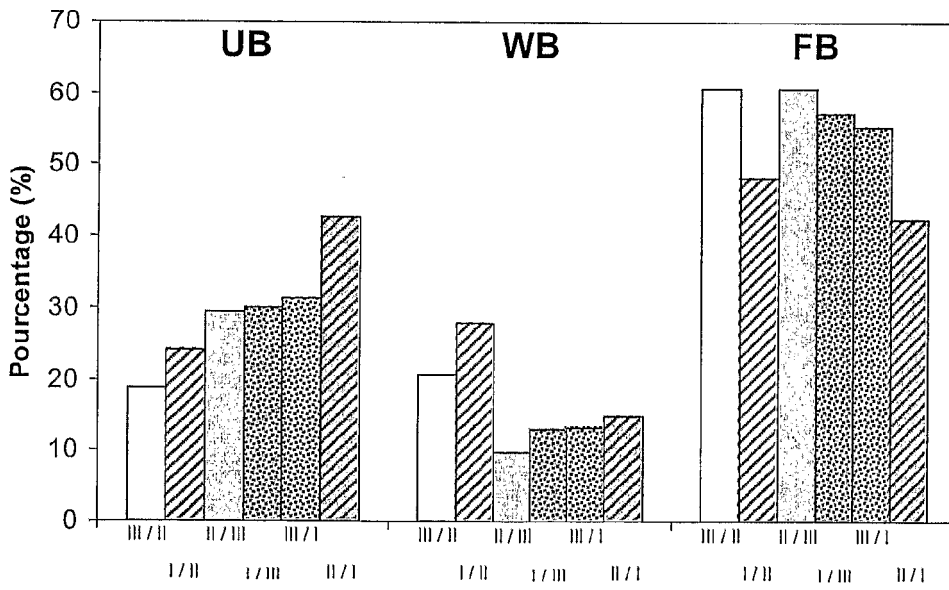

Figure 18

19/22

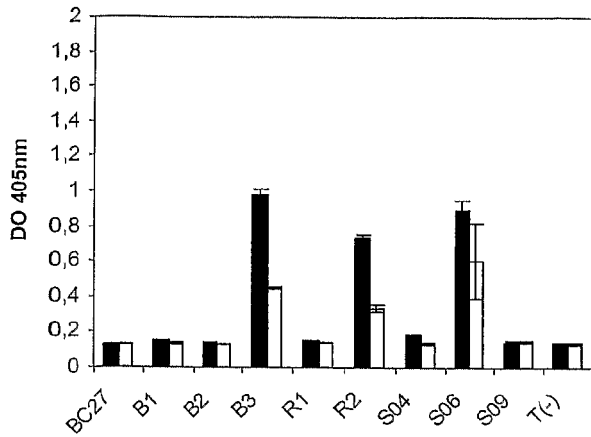

Figure 19A

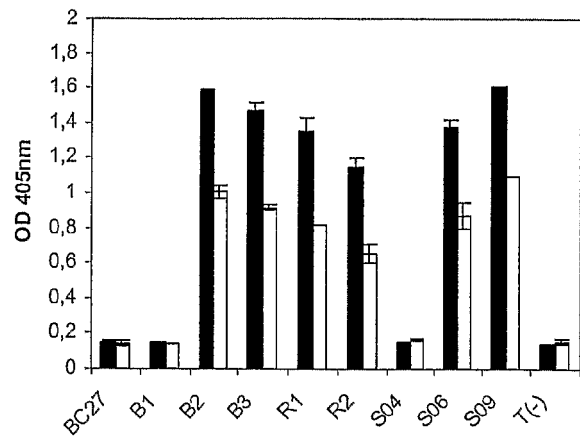

Figure 19B

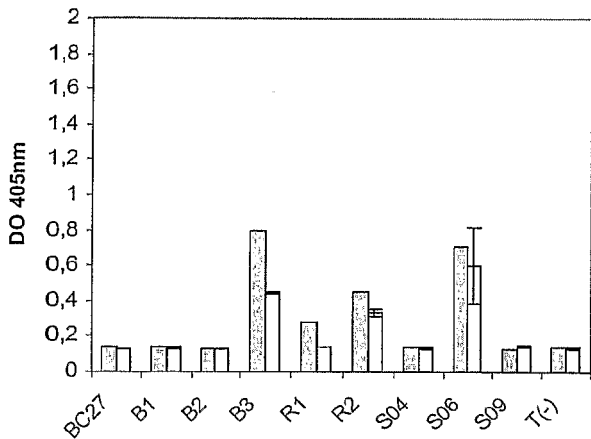

Figure 19C

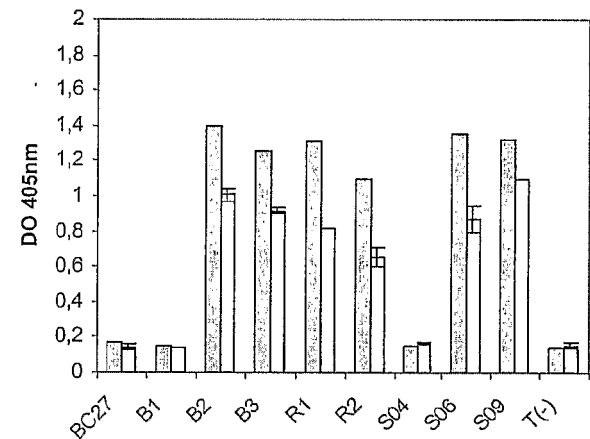

Figure 19D

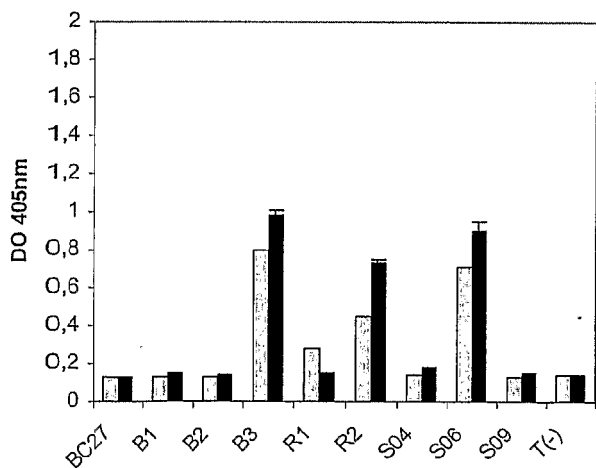

Figure 19E

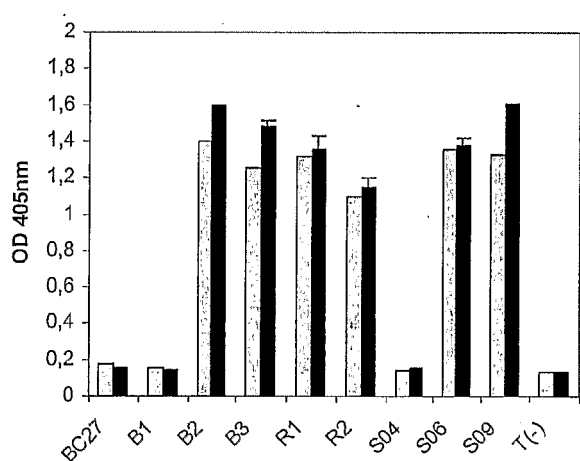

Figure 19F

20/22

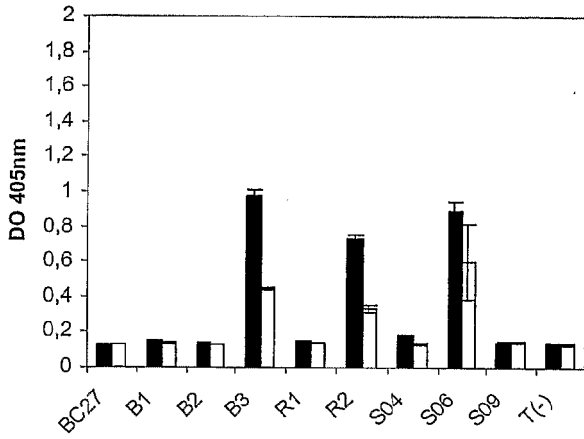

Figure 19G

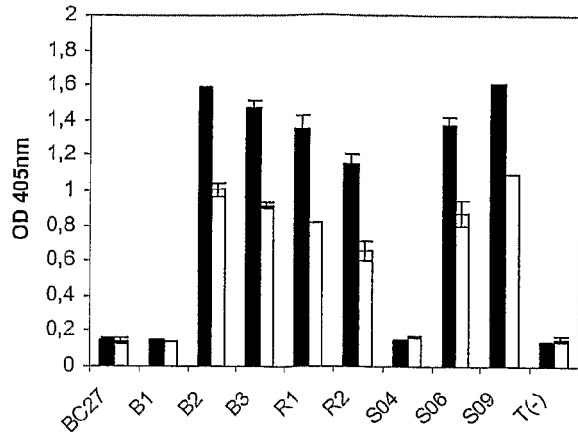

Figure 19H

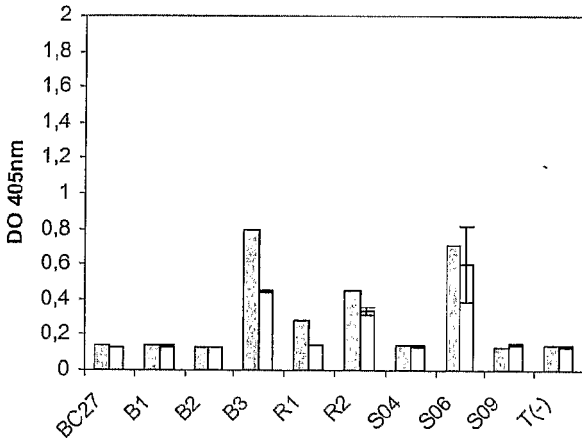

Figure 19I

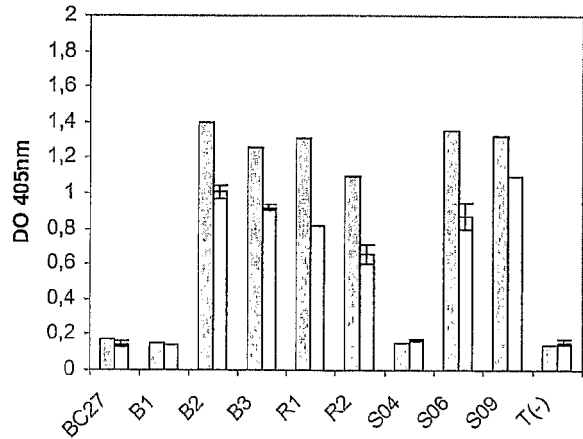

Figure 19J

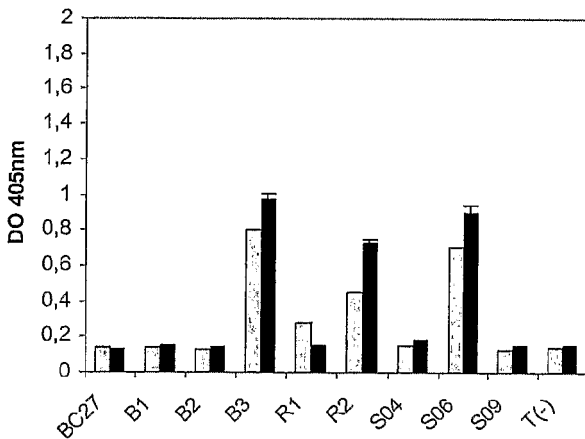

Figure 19K

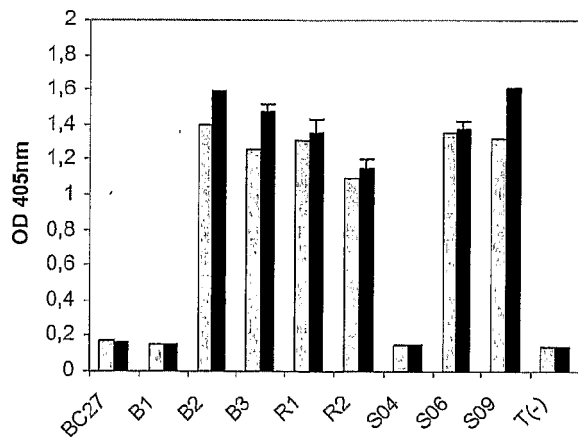

Figure 19L

21/22

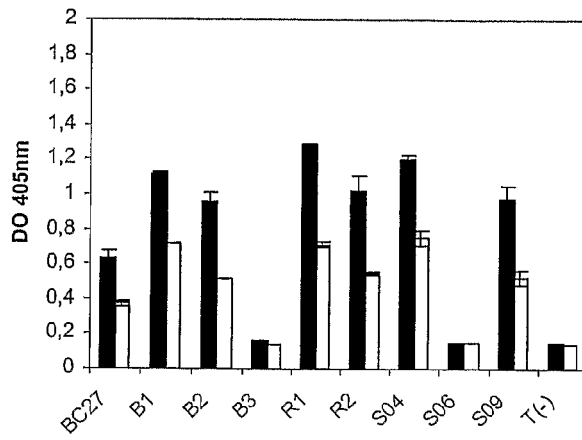

Figure 19M

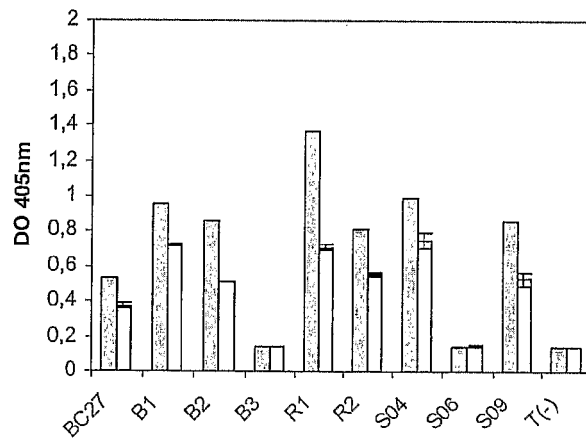

Figure 19N

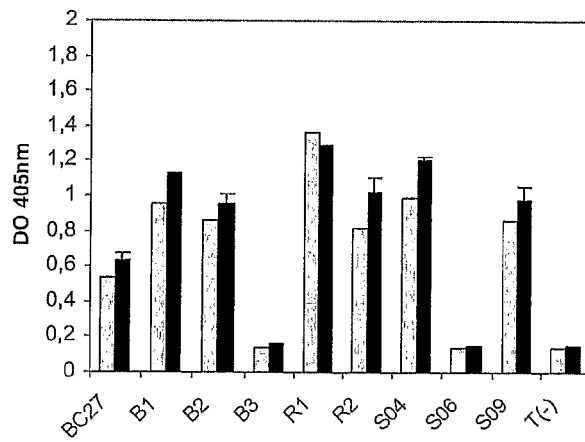

Figure 19O

22/22

Figure 20A

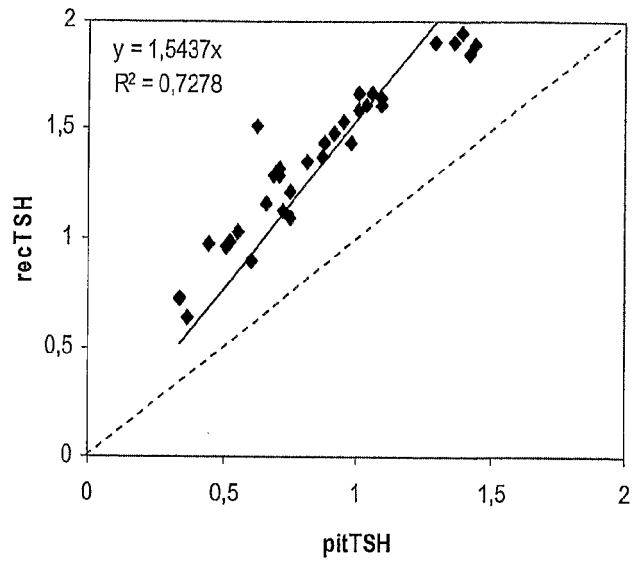

Figure 20B

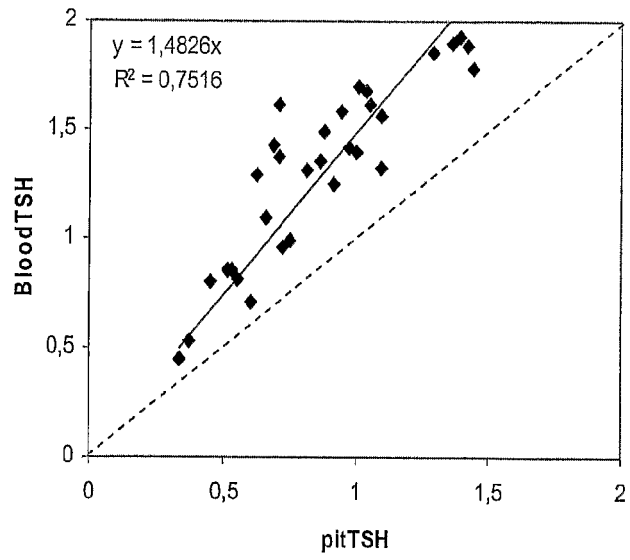
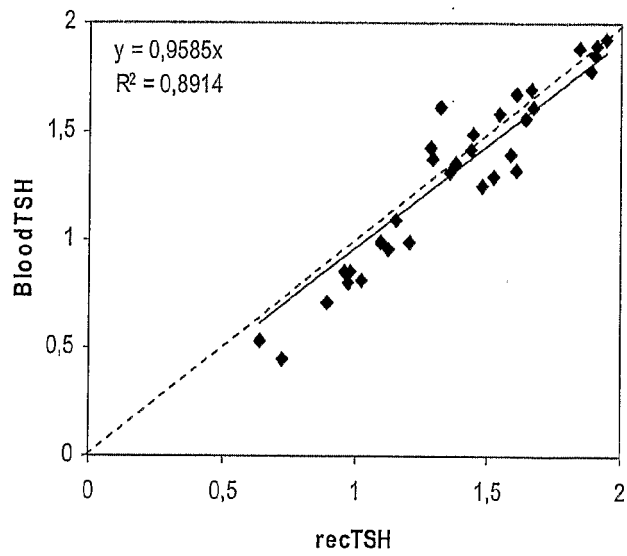

Figure 20C



SEQUENCE LISTING

<110> CENTRE NATIONAL DE LA RECHERCHE SCIENTIFIQUE  
UNIVERSITE D'AIX-MARSEILLE I

<120> PROCESS FOR SCREENING GLYCOFORM-SPECIFIC ANTIBODIES

<130> WOB 03 CE CNR COFO

<160> 1

<170> PatentIn version 3.1

<210> 1

<211> 317

<212> PRT

<213> Artificial sequence

<220>

<223> 1-89 deletion mutant of human ST6GalI

<400> 1

Glu Ala Ser Phe Gln Val Trp Asn Lys Asp Ser Ser Ser Lys Asn Leu  
1 5 10 15

Ile Pro Arg Leu Gln Lys Ile Trp Lys Asn Tyr Leu Ser Met Asn Lys  
20 25 30

Tyr Lys Val Ser Tyr Lys Gly Pro Gly Pro Gly Ile Lys Phe Ser Ala  
35 40 45

Glu Ala Leu Arg Cys His Leu Arg Asp His Val Asn Val Ser Met Val  
50 55 60

Glu Val Thr Asp Phe Pro Phe Asn Thr Ser Glu Trp Glu Gly Tyr Leu  
65 70 75 80

Pro Lys Glu Ser Ile Arg Thr Lys Ala Gly Pro Trp Gly Arg Cys Ala  
85 90 95

Val Val Ser Ser Ala Gly Ser Leu Lys Ser Ser Gln Leu Gly Arg Glu  
100 105 110

Ile Asp Asp His Asp Ala Val Leu Arg Phe Asn Gly Ala Pro Thr Ala  
115 120 125

Asn Phe Gln Gln Asp Val Gly Thr Lys Thr Thr Ile Arg Leu Met Asn  
130 135 140

Ser Gln Leu Val Thr Thr Glu Lys Arg Phe Leu Lys Asp Ser Leu Tyr  
145 150 155 160

Asn Glu Gly Ile Leu Ile Val Trp Asp Pro Ser Val Tyr His Ser Asp  
165 170 175

- 2 -

Ile Pro Lys Trp Tyr Gln Asn Pro Asp Tyr Asn Phe Phe Asn Asn Tyr  
 180 185 190

Lys Thr Tyr Arg Lys Leu His Pro Asn Gln Pro Phe Tyr Ile Leu Lys  
 195 200 205

Pro Gln Met Pro Trp Glu Leu Trp Asp Ile Leu Gln Glu Ile Ser Pro  
 210 215 220

Glu Glu Ile Gln Pro Asn Pro Pro Ser Ser Gly Met Leu Gly Ile Ile  
 225 230 235 240

Ile Met Met Thr Leu Cys Asp Gln Val Asp Ile Tyr Glu Phe Leu Pro  
 245 250 255

Ser Lys Arg Lys Thr Asp Val Cys Tyr Tyr Tyr Gln Lys Phe Phe Asp  
 260 265 270

Ser Ala Cys Thr Met Gly Ala Tyr His Pro Leu Leu Tyr Glu Lys Asn  
 275 280 285

Leu Val Lys His Leu Asn Gln Gly Thr Asp Glu Asp Ile Tyr Leu Leu  
 290 295 300

Gly Lys Ala Thr Leu Pro Gly Phe Arg Thr Ile His Cys  
 305 310 315

专利名称(译)	筛选糖型特异性抗体的方法		
公开(公告)号	<a href="#">EP1711834A2</a>	公开(公告)日	2006-10-18
申请号	EP2005701355	申请日	2005-02-04
[标]申请(专利权)人(译)	法国国家科学研究中心 UNIV普罗旺斯		
申请(专利权)人(译)	CENTRE法国国家科学研究 普罗旺斯大学		
当前申请(专利权)人(译)	CENTRE法国国家科学研究 普罗旺斯大学 ( 马赛1 )		
[标]发明人	RONIN CATHERINE DONADIO SANDRINE		
发明人	RONIN, CATHERINE DONADIO, SANDRINE		
IPC分类号	G01N33/76 C07K16/26 G01N33/569 C07K14/59 C07K16/00 G01N33/53 G01N33/564 G01N33/68		
CPC分类号	C07K16/26 G01N33/6854		
优先权	2004290290 2004-02-04 EP		
其他公开文献	EP1711834B1		
外部链接	<a href="#">Espacenet</a>		

#### 摘要(译)

本发明涉及评估 - 第一种糖蛋白引发的抗体与第二种糖蛋白的至少一种糖型之间的结合的用途，所述第二种糖蛋白本身是第一种蛋白质的糖型，其中所述糖型是第一种蛋白质的糖型。第二糖蛋白选自第二糖蛋白的一组糖型，所述组的每个糖型对应于由确定的唾液酸化状态和/或确定的支化状态和/或确定的岩藻糖基化状态限定的确定的糖基化状态，条件是所述糖基化状态不是由基本上未唾液酸化状态唯一定义的，用于筛选针对第二糖蛋白的给定糖型的糖型特异性抗体。