



**Description****RELATED APPLICATIONS**

5 [0001] This application claims priority under 35 U.S.C. §119(e) to U.S. Provisional Patent Application No. 61/149,253, filed February 2, 2009, and entitled "Structures for Controlling Light Interaction with Microfluidic Devices," which is incorporated herein by reference in its entirety for all purposes.

**FIELD OF INVENTION**

10 [0002] The present invention relates generally to microfluidic systems, and more specifically, to systems and methods for controlling light interaction with microfluidic devices.

**BACKGROUND**

15 [0003] Optical analysis of fluids plays an important role in fields such as chemistry, microbiology and biochemistry. These fluids may include liquids or gases and may provide reagents, solvents, reactants, or rinses to chemical or biological processes. While various microfluidic methods and devices, such as microfluidic assays, can provide inexpensive, sensitive and accurate analytical platforms, carrying out accurate optical measurements (e.g., absorbance or transmission) on a microfluidic system can be challenging. Optical measurements of microchannels may require, for example, time-consuming alignment procedures. In addition, optical noise produced by light incident upon areas outside the channels may degrade the quality of the detected signal through the channels. Accordingly, advances in the field that could reduce costs, simplify use, and/or improve optical detection in microfluidic systems would be beneficial.

**SUMMARY OF THE INVENTION**

25 [0004] Systems and methods for controlling light interaction with microfluidic devices are provided. The subject matter of the present invention involves, in some cases, interrelated products, alternative solutions to a particular problem, and/or a plurality of different uses of one or more systems and/or articles.

30 [0005] In one set of embodiments, a series of fluidic devices are provided. In one particular embodiment, a fluidic device comprises an article including first and second opposing sides and first and second microfluidic channel segments, each integral to the first side of the article. The fluidic device also includes an intervening portion positioned substantially between the first and second microfluidic channel segments, and a first optical element integral to the second side of the article and positioned substantially between the first and second channel segments, and opposite the intervening portion. The first optical element is adapted and arranged such that when a portion of the article is exposed to light at a first intensity, the first optical element redirects at least a portion of the light away from the intervening portion, such that the intervening portion is not exposed to the light or is exposed to the light at a second intensity lower than an intensity of the light at the intervening portion absent the first optical element.

35 [0006] In another embodiment, a fluidic device comprises an article comprising first and second sides, a first microfluidic channel segment integral to the first side of the article, and first and second optical elements, each integral to the second side of the article, wherein the first microfluidic channel segment is positioned substantially between the first and second optical elements. A cover is positioned over the first microfluidic channel segment so as to substantially enclose the first microfluidic channel segment. Furthermore, an intervening surface portion at the second side of the article is positioned substantially between the first and second optical elements, the intervening surface portion being substantially parallel to a surface portion of the cover that substantially encloses the first microfluidic channel segment.

40 [0007] In another embodiment, a fluidic device comprises an article comprising first and second sides, and first and second microfluidic channel segments, each integral to the first side of the article. The fluidic device also includes a first substantially triangular optical element integral to the second side of the article and positioned substantially between the first and second channel segments.

45 [0008] In some instances, the first and/or second microfluidic channel segments described above and herein are sections of a microfluidic channel comprising a meandering configuration including multiple turns, each turn of the meandering channel being a different channel segment.

50 [0009] Other advantages and novel features of the present invention will become apparent from the following detailed description of various non-limiting embodiments of the invention when considered in conjunction with the accompanying figures. In cases where the present specification and a document incorporated by reference include conflicting and/or inconsistent disclosure, the present specification shall control. If two or more documents incorporated by reference include conflicting and/or inconsistent disclosure with respect to each other, then the document having the later effective date shall control.

**BRIEF DESCRIPTION OF THE DRAWINGS**

**[0010]** Non-limiting embodiments of the present invention will be described by way of example with reference to the accompanying figures, which are schematic and are not intended to be drawn to scale. In the figures, each identical or nearly identical component illustrated is typically represented by a single numeral. For purposes of clarity, not every component is labeled in every figure, nor is every component of each embodiment of the invention shown where illustration is not necessary to allow those of ordinary skill in the art to understand the invention. In the figures:

FIGS. 1A-1E include schematic diagrams of a device including optical elements that can be used to control light interaction on or within the device, according to one set of embodiments;

FIGS. 2A-2B include schematic cross-sectional diagrams of devices showing light interactions in the devices, according to one set of embodiments;

FIGS. 3A-3C include, according to one set of embodiments, schematic diagrams of channel configurations in certain devices;

FIGS. 4A-4B include cross-sectional diagrams illustrating a fabrication process, according to one set of embodiments;

FIG. 5 includes a plot of optical density as a function of dye concentration, according to one set of embodiments;

FIGS. 6A-6D include cross-sectional schematic diagrams and associated plots of transmitted light as a function of detector position, according to one set of embodiments;

FIGS. 7A-7C include cross-sectional schematic diagrams, optical micrographs, and a plot of optical density as a function of dye concentration, according to one set of embodiments;

FIGS. 8A-8C include schematic diagrams illustrating various sensor layouts, according to one set of embodiments;

FIGS. 9A-9D include plots of transmitted light as a function of sensor position, according to one set of embodiments; and

FIG. 10 includes a plot of optical density as a function of dye concentration, according to one set of embodiments.

**DETAILED DESCRIPTION**

**[0011]** Systems and methods for improved measurement of absorbance/transmission through fluidic systems are described. Specifically, in one set of embodiments, optical elements are fabricated on one side of a transparent fluidic device opposite a series of fluidic channels. The optical elements may guide incident light passing through the device such that most of the light is dispersed away from specific areas of the device, such as intervening portions between the fluidic channels. By decreasing the amount of light incident upon these intervening portions, the amount of noise in the detection signal can be decreased when using certain optical detection systems. In some embodiments, the optical elements comprise triangular grooves formed on or in a surface of the device. The draft angle of the triangular grooves may be chosen such that incident light normal to the surface of the device is redirected at an angle dependent upon the indices of refraction of the external medium (e.g., air) and the device material.

**[0012]** Advantageously, certain optical elements described herein may be fabricated along with the fluidic channels of the device in one step, thereby reducing the costs of fabrication. Furthermore, in some cases the optical elements do not require alignment with a detector and, therefore, facilitate assembly and/or use by an end user. Other advantages are described in more detail below.

**[0013]** Additional techniques may be employed to reduce the amount of stray light transmitted through the fluidic device. For example, in some instances, the widths of the intervening portions between the channel segments may be reduced. Also, the light source may be arranged such that light is emitted only over portions of the device that lie above the channel segments. Both of these techniques may reduce the amount of light transmitted through the intervening portions, thus improving the quality of the optical image. In some embodiments, the fluidic device may include a detector array arranged such that the areas of the array under the channel segments are sensitive to light, while the other areas of the array are not.

**[0014]** The systems and methods described herein may find application in a variety of fields. In some cases, the systems and methods can be used to improve the optical performance of any microfluidic system such as, for example, microfluidic point-of-care diagnostic platforms, microfluidic laboratory chemical analysis systems, optical monitoring systems in cell cultures or bio-reactors, among others. Optical measurements in microfluidic systems may be used to monitor any suitable chemical and/or biological reaction as it takes place, diagnostic or otherwise. As a specific example, an optical measurement step can be used during DNA synthesis to verify the yield of each base addition (e.g., optical trityl monitoring) and during some forms of PCR amplification to monitor the process.

**[0015]** Previous systems, such as those described in International Patent Publication No. WO2006/11372 (International Patent Application Serial No. PCT/US2006/014583), filed April 19, 2006 and entitled "Fluidic Structures Including Meandering and Wide Channels," have made use of a meandering microchannel to image a two-dimensional space. For example, a microfluidic channel may be in the form of a tight "S" shape having multiple channel segments, forming an

area of about 2 mm, e.g., a "measurement area" including both channel and non-channel regions. In certain embodiments, this measurement area does not require fine alignment for optical measurements (unlike a single straight channel) and forms a measurement area which can be easily interrogated optically. For instance, a detector may be positioned over all or a portion of the measurement area made up of channel and non-channel regions. One limitation of the use of meandering structures in the context of transmission measurement, though, is that some of the light shining through these measurement areas will pass through the intervening portions between the microfluidic channel segments (that is, the non-channel regions). This light may reach the optical detector without reflecting changes in the optical density of the contents of the microchannel. This "stray light" can reduce the overall performance of the optical detection. This effect may be particularly problematic when making measurements of channels with high levels of optical density. A large amount of stray light on the detector may wash out any changes in small amounts of light passing through the microchannels.

**[0016]** The inventors have discovered within the context of the invention that the amount of light that passes through an intervening portion between microfluidic channels or channel segments may be reduced or substantially eliminated by fabricating, in the device, at least one optical element. The optical element may redirect at least a portion of the light away from the intervening portion, such that the intervening portion is not exposed to the light or is exposed to the light at a second intensity lower than an intensity of light to which the intervening portion would be exposed in the absence of the optical element. The incorporation of optical elements into microfluidic channel systems enhances the performance of the detection system, allowing the use of simplified optics without compromising the quality of the optical measurements.

**[0017]** Furthermore, the systems and methods described herein may be used to improve alignment in micro-scale optical detection systems. Certain methods for optical detection/measurements in microsystems are challenging in that they require accurate alignment of the optics with micro-scale features (e.g., microchannels). Such alignment can be performed manually (e.g., with a microscope and micrometric stage) in a labor-intensive fashion, or in an automated manner (e.g., using complex robotic positioning systems). These techniques, however, often require a skilled and attentive operator or expensive, delicate automation, making them suboptimal for certain applications. The ability of the optical elements to redirect light away from one or more intervening portions between microfluidic channel segments may eliminate or reduce the need for such complicated alignment procedures.

**[0018]** Additionally, the positioning of a detector over a measurement area without the need for precision is an advantage, since external (and possibly, expensive) equipment such as microscopes, lenses, and alignment stages may not be required. Instead, alignment can be performed by eye, or by low-cost methods that may not require an alignment step by the user. For example, in one embodiment, a fluidic device comprising one or more optical elements and a measurement area including both channel and non-channel regions can be placed in a simple holder (i.e., in a cavity having the same shape as the fluidic device), and the measurement area can be automatically aligned with a beam of light of the detector.

**[0019]** It should be noted that the systems and methods described herein may be used for guiding light in any suitable system utilizing microfabricated structures, and are not limited to microfluidic systems and/or the specific channel configurations described herein.

**[0020]** Additional advantages of devices including optical elements constructed to redirect light are described in more detail below.

**[0021]** The articles, systems, and methods described herein may be combined with those described in International Patent Publication No. WO2005/066613 (International Patent Application Serial No. PCT/US2004/043585), filed December 20, 2004 and entitled "Assay Device and Method"; International Patent Publication No. WO2005/072858 (International Patent Application Serial No. PCT/US2005/003514), filed January 26, 2005 and entitled "Fluid Delivery System and Method"; International Patent Publication No. WO2006/113727 (International Patent Application Serial No. PCT/US06/14583), filed April 19, 2006 and entitled "Fluidic Structures Including Meandering and Wide Channels"; U.S. Patent Application Serial No. 12/113,503, filed May 1, 2008 and entitled "Fluidic Connectors and Microfluidic Systems"; U.S. Patent Apl. Serial No. 12/196,392, filed August 22, 2008, entitled "Liquid containment for integrated assays"; U.S. Patent Apl. Serial No. 12/428,372, filed April 22, 2009, entitled "Flow Control in Microfluidic Systems"; U.S. Patent Apl. Serial No. 61,263,981, filed November 24, 2009, entitled "Fluid Mixing and Delivery in Microfluidic Systems"; and U.S. Patent Apl. Serial No. 12/640,420 filed on December 17, 2009 and entitled, "Improved Reagent Storage in Microfluidic Systems and Related Articles and Methods," each of which is incorporated herein by reference in its entirety for all purposes. In addition, U.S. Provisional Patent Application Serial No. 61/149,253, filed February 2, 2009, entitled "Structures for Controlling Light Interaction with Microfluidic Devices," is incorporated herein by reference in its entirety for all purposes.

**[0022]** Examples of fluidic devices and methods associated therewith are now provided.

**[0023]** FIGs. 1A-1E show various portions of a fluidic device including optical elements that can be used to control light interaction on or within the device. FIG. 1A shows a cross section and FIG. 1B shows a perspective view of a fluidic device 10 which includes an article 12 having a first surface 14 and a second surface 16, as well as a first side 20 and a second side 22.

**[0024]** As used herein, "first and second sides" of an article generally refers to the relative orientation of two portions of the article. First and second sides may refer to first and second surfaces of the article, or to a portion of the article that does not encompass a surface, e.g., a portion of the article that is embedded within the bulk of the article. For example, first and second microfluidic channel segments that are said to be integral to the first side of the article may be integral to a surface at the first side of the article or embedded within the article at the first side. FIG. 1A also shows the first side opposing the second side. Two sides are said to be "opposing" when they are substantially parallel to each other and separated by a distance.

**[0025]** As shown illustratively in FIGS. 1A and 1C, first side 20 includes a plurality of channel segments (first 26, second 28, and third 30) formed therein. A channel segment refers to a portion of a fluidic channel that spans an entire cross-section of the channel and has a length substantially parallel to fluid flow. A channel segment may have any suitable length, e.g., at least 1 mm, at least 5 mm, at least 1 cm, or at least 5 cm in certain embodiments. While three channel segments are shown in FIG. 1A, systems and methods described herein may comprise any suitable number of channel segments and may be configured in any suitable arrangement. For instance, channel segments of a device may be a part of the same fluidic channel, or may be part of separate fluidic channels that are not in fluid communication with one another.

**[0026]** In some embodiments, channel segments refer to a series of repetitive units of one or more channels; for example, each channel of an array of channels may be a channel segment. In another example, a channel includes a plurality of reaction areas positioned in series, and each channel portion associated with a distinct reaction area is a channel segment. In certain cases, channel segments are sections of a fluidic channel having a meandering configuration, each "turn" of the meandering channel being a different channel segment. As used herein, a "meandering channel" (i.e., a channel having a meandering region) includes at least a first segment that has a flow path in a first direction and a second segment that has a flow path in a second direction substantially opposite (e.g., greater than 135 degrees from) the first direction. Often, a meandering channel will include more than two alternating channel segments that extend in opposite directions. Examples of meandering channel regions are provided below.

**[0027]** In some embodiments, the two or more channel segments of a device are spaced apart from each other by intervening portions, i.e., non-channel portions. For instance, first side 20 includes intervening portions 27 and 29. An intervening portion may include portions of a surface of an article (e.g., surface portion 14' of FIG. 1A) and/or a portion of the article that does not encompass a surface (e.g., portions 15 of FIG. 1A). In some embodiments, an intervening portion has one or more dimensions (e.g., a width, height, and/or length) of at least 0.5 mm, at least 1 mm, at least 5 mm, at least 1 cm, or at least 5 cm in certain embodiments. A dimension of an intervention portion may, for example, define the distance between two channel segments.

**[0028]** The fluidic device illustrated in FIGS. 1A and 1C also includes a cover 31 positioned over the plurality of channel segments. The cover may be positioned over the channel segments so as to substantially enclose the channel segments. In some instances, the cover may comprise a tape (e.g., flexible tape), glass (e.g., a cover slide), rigid plastic, or any other suitable material as described in more detail below.

**[0029]** In the set of embodiments illustrated in FIGS. 1A and 1C, second side 22 includes a plurality of optical elements (first 32 and second 34) formed therein. As used herein, the term "optical element" is used to refer to any feature formed or positioned on or in an article or device that changes the direction (e.g., via refraction or reflection), focus, polarization, and/or other property of incident electromagnetic radiation relative to the light incident upon the article or device in the absence of the element. For example, an optical element may comprise a lens (e.g., concave or convex), mirror, grating, groove, or other feature formed or positioned in or on an article. An article itself absent a unique feature, however, would not constitute an optical element, even though one or more properties of incident light may change upon interaction with the article.

**[0030]** FIGS. 1A and 1C also show an intervening surface portion 33 between the first and second optical elements. As shown in FIG. 1A, the intervening surface portion may be substantially parallel to the surface portion of the cover that substantially encloses the microfluidic channel segments. While two optical elements are shown in FIGS. 1A and 1C, the articles described herein may comprise any suitable number of optical elements and any suitable number of intervening surface portions between the optical elements. Furthermore, some articles do not include intervening surface portions between the optical elements, e.g., a series of optical elements may be configured to form alternating ridges and grooves in a corrugated fashion.

**[0031]** The optical elements described herein may be, in some cases, substantially transparent (e.g., to visible light, infrared radiation, etc.). In other embodiments, optical elements may comprise a substantially opaque material. In some cases, optical elements may comprise one or more reflective surfaces. For example, an optical element may comprise a channel, the walls of which are coated with a reflective material such as a metal (e.g., Ni, Ag, Au, Pt) or a semiconductor (e.g., Si, glass).

**[0032]** An optical element may comprise a groove, which may be open or substantially enclosed. As shown in the embodiment illustrated in FIGS. 1A and 1C, optical elements 32 and 34 are in the form of grooves that are substantially triangular; however, other shapes are also possible. For instance, in other embodiments, the cross-section of an optical

element may be of any suitable shape such as a hemisphere, square, rectangle, trapezoid, etc. Some optical elements have a semi-spherical or semi-ovular shape. The shape and/or angle of the groove may be selected such that incident light normal to the surface of the device is redirected away from the area directly below the groove. This may enhance the probability that little or no light is incident upon unwanted areas around the channels (e.g., intervening portions 27 and 29), reducing the amount of noise in the detection signal. Accordingly, an optical element may have any suitable size, configuration, and/or shape to achieve improvements in signal to noise, as described in more detail below.

**[0033]** In some cases, an optical element may be a feature that protrudes from a surface of an article. For example, FIG. 1D includes triangular optical elements 32 and 34 formed in the shape of a prism. It should be understood that "triangular" optical elements include any elements that are triangular in cross-section, whether formed in a substrate (e.g., as in FIG. 1A) or on a substrate (e.g., as in FIG. 1D). Other shapes that may be formed include, for example, half-cylinders, rectangular prisms, etc.

**[0034]** An optical element may comprise, in some cases, one or more fluids (e.g., a dye). For example, in one set of embodiments, the optical element is formed as a channel (e.g., by placing a cover over surface 16 of the article) and the channel is filled with a light-absorbing fluid such as an opaque dye. Dyes of any suitable concentration may be used. In some embodiments, the concentration of the dye may be at least about 0.1 grams, at least about 0.5 grams, at least about 1 gram, at least about 5 grams, at least about 10 grams, at least about 50 grams, or at least about 100 grams of dye material per mL of solvent (e.g., water).

**[0035]** FIG. 1C shows a schematic diagram of an optical device during operation, according to one set of embodiments. During operation, fluidic device 10 is positioned between a light source 36 and an optical detector 38 such that first side 20 (comprising one or more channel segments) faces the detector and second side 22 (comprising one or more optical elements) faces light source 36 and is exposed to light 42. The detector may be associated with one or more fluidic channel segments in the fluidic device, e.g., to determine light transmission through one or more of the channel segments. In one set of embodiments, when a portion of the article is exposed to light at a first intensity, the optical elements redirect at least a portion of the light away from the intervening portions. For example, one or more optical elements may be adapted and arranged so as to redirect at least a portion of the light away from a surface portion of the first side, the surface portion being adjacent to at least one channel segment. In FIG. 1C, optical element 32 is adapted and arranged to redirect light away from intervening portion 27, which includes surface portion 14'. Similarly, optical element 34 is adapted and arranged to redirect light away from intervening portion 29, which includes surface portion 49. Redirecting light may include, for instance, reflecting the light (e.g., away from the article), refracting the light (e.g., through the article in a direction away from the intervening portion), or both.

**[0036]** One or more optical elements may be constructed and arranged to redirect at least about 10%, at least about 25%, at least about 50%, at least about 75%, or at least about 90% of incident light away from an intervening portion. As light is redirected, the intervening portions are not exposed to the light or are exposed to the light at a second intensity lower than an intensity of the light at the intervening portion absent the optical elements. For example, in some cases, at least one optical element is adapted and arranged such that the intervening portions are exposed to the light at a second intensity at least about 50% lower, at least about 75% lower, or at least about 90% lower than an intensity of the light at the intervening portion absent the optical elements.

**[0037]** In some embodiments, one or more optical elements are adapted and arranged so as to redirect at least a portion of the light away from the center plane (e.g., 32' and 34' in FIG. 1A) of the optical element, such that the underlying portion of the device directly below the optical element is not exposed to light or is exposed to light at a second intensity lower (e.g., about 25% lower) than the intensity to which the underlying portion would be exposed were the optical element absent. As used herein, a region is "directly below" an object when it lies on the side of an object opposite that which is exposed to light from the source. The region directly below an object may span the width of the object and the depth of the article perpendicular to the outermost surface on either the first or second side of the object. For example, in FIG. 1C, region 52 lies directly below optical element 34.

**[0038]** An example of the use of optical elements to redirect light is shown in FIG. 1C. As illustrated in FIG. 1C, portion 44 of article 12 is exposed to light 42 from the light source. In some cases, the light source and device are oriented such that the angle of incidence of the light on surface 16 is between about 85° and about 95°, or at substantially 90°. At surface 16, light that is incident on areas absent the optical elements is transmitted into the bulk of the device without a substantial change in direction, as indicated by arrows 42. Light incident upon optical element 32, however, interacts at an angle substantially different than 90°. Optical element 32 redirects at least a portion of the light away from intervening portion 27, e.g., by reflection, refraction, and/or both. Arrows 46' represent light that is reflected away from the optical element, while arrows 46 illustrate light that is refracted through the article, but away from intervening portions between the fluidic channels. Thus, intervening portion 27 is not exposed to the light, or is exposed to the light at an intensity less than it would have been in the absence of optical element 32. Furthermore, although not shown in this figure, light may be absorbed by the article or redirected at other angles, thereby reducing the amount of light detected by the detector at intervening portion 27. Optical element 34 functions in a similar manner, in this case redirecting light away from intervening portion 29 and generally away from region 52 directly below the optical element.

**[0039]** In some cases, one or more optical elements are adapted and arranged to redirect at least a portion of the incident light into one or more fluidic channels on the opposite side of the article. For example, as shown in FIG. 1C, a portion of the light incident upon optical element 32 is refracted through the article and redirected into fluidic channels 26 and 28. Advantageously, this can increase the amount of light used to interrogate a sample in fluidic channels 26 and 28.

**[0040]** It should be understood that while much of the description and figures herein describe the positioning of optical elements at a side of an article opposite the channels, in some cases the optical elements may be positioned at the same side as the channels. For instance, optical elements 32 and 34 of FIG. 1A-1D may be formed in surface 14 and may optionally include a reflective surface so as to redirect light 42' away from portion 43 of the detector. In other cases, an article may include a combination of optical elements formed in or on both surfaces of the article. The geometry of the device and configuration of features may be chosen, in some cases, such that any light passing through the bulk of the article from a first side is redirected toward the channels on the opposite side of the article. The design of a system with optical elements may be undertaken with the goal of both reflecting light and re-directing light away from the intervening portions between channels. Without wishing to be bound by theory, the design of a fluidic device may take into account the following:

**[0041]** The trajectory of refracted light is determined by Snell's Law:

$$n_1 \sin(\beta_1) = n_2 \sin(\beta_2) \quad [1]$$

where  $n_1$  and  $n_2$  are the indices of refraction of the medium in which the light originates and is transmitted, respectively,  $\beta_1$  is the angle between the angle of incidence and the normal at the interface, and  $\beta_2$  is the angle of refraction, as outlined in FIG. 1E.

**[0042]** Design features that may be varied to increase the amount of light redirected away from the intervening portions include, for example, the width of the channel ( $W$ ), the pitch of the optical elements ( $P1$ ), the pitch of the channels ( $P2$ ), the depth of the channel ( $D$ ), the width of the optical elements ( $V$ ), the draft angle of the optical elements ( $\alpha$ ), the thickness of the microfluidic substrate ( $T$ ), the index of refraction of microfluidic substrate ( $n_2$ ), the index of refraction of external medium ( $n_1$ ), and the incident angle of light on the substrate (assume perpendicular to substrate).

**[0043]** For example, FIG. 2A includes device 210 comprising substrate 211 in which channels 212, 213, and 214 and optical elements 216, 217, 218 and 219 are formed. The thickness of the substrate is illustrated by dimension 220 in FIG. 2A. The width of a channel is measured as the widest cross-sectional dimension of the channel substantially parallel to the surface in which it is formed. For example, the width of channel 213 is indicated by dimension 221 in FIG. 2A. The half-width of channel 214 is indicated by dimension 222. Similarly, the width of an optical element is also measured as the widest cross-sectional dimension of the element substantially parallel to the surface in or on which it is formed. For example, the width of optical element 218 is indicated by dimension 224 in FIG. 2A. The depths of the channels, as indicated by dimension 226 in FIG. 2A, are measured perpendicular to the surface in which they are formed.

**[0044]** The pitch of two channels is measured as the distance between a first point on a first channel and a second point on a second channel, wherein the first and second points are located in similar positions within their respective channels. In other words, the pitch is equal to the width of a channel plus the gap between that channel and the adjacent channel. For example, in FIG. 2A, the pitch of channels 213 and 214 may be measured as the distance between similar edges of the channels, as indicated by dimension 230. In some embodiments, the pitches of all adjacent channels are substantially constant, as indicated in FIG. 2A; however, in other cases the pitches between channels may vary. The pitch of two optical elements is measured in a similar manner as shown, for example, by dimension 232 in FIG. 2A. In some embodiments, the pitches of all adjacent optical elements may be substantially constant, or may vary, e.g., depending on the particular light interaction desired.

**[0045]** To minimize stray light, improved results are obtained in some embodiments when the pitch ( $P1$ ) of the optical elements matches the pitch of the channels ( $P2$ ). The width of the optical elements ( $V$ ) may be chosen such that the area between the optical elements ( $P-V$ ) is less than the width of the channel ( $W$ ). As ( $P-V$ ) decreases relative to  $W$ , the percentage of incident light that is redirected by the optical elements increases. To increase the amount of light redirected away from the intervening portions by the optical elements, the thickness of the system may be set so that light refracted by the optical elements is directed onto the channels. Since there may be multiple channels, there may be multiple preferred thicknesses for the system.

**[0046]** One may create a model to calculate preferred thicknesses by imagining an incident light ray (e.g., perpendicular to the article) striking the article halfway between the bottom and the edge of the optical element (see, for example, light ray 240 in FIG. 2A). The thickness of the article may be selected such that this light reaches the center of a channel. To determine this thickness, one may begin by calculating the angle of the refracted light to the vertical within the substrate ( $\beta$ ). This angle is a function of the angle of incidence, the draft angle of the optical element, and the angle of refraction. Examining the geometry, one can see:

$$\beta_1 = 90 \text{ deg.} - \alpha \quad [2]$$

$$\theta = 90 \text{ deg.} - \alpha - \beta_2 = \beta_1 - \beta_2 \quad [3]$$

Using Snell's Law (Equation 1), the angle of refraction ( $\beta_2$ ) can be calculated as:

$$\beta_2 = \sin^{-1} \left( \frac{n_1}{n_2} \sin \beta_1 \right) \quad [4]$$

Therefore:

$$\theta = 90 \text{ deg.} - \alpha - \sin^{-1} \left( \frac{n_1}{n_2} \sin(90 \text{ deg.} - \alpha) \right) \quad [5]$$

If one were to assume a draft angle ( $\alpha$ ) of 35.3°, an article refractive index ( $n_2$ ) of 1.57 (e.g., polystyrene), and a refractive index of air ( $n_1$ ) of roughly 1.0, the internal angle of refraction would be 23.4°.

**[0047]** Following this ray of from the center of the side of the optical element to the center of a channel, this angle can be used to calculate an intermediate measure of thickness ( $t$ ):

$$\tan \theta = \frac{x}{t} \quad [6]$$

The distance ( $x$ ) from the point below the incident light and the center of a the closest channel is half the pitch minus the distance between the bottom of the optical element and the edge ( $V/4$ ). The center of any additional channel is a multiple of the pitch. Note that in FIG. 2A, the thickness was chosen to direct the refracted light onto a channel two channels away ( $n=2$ ) from the closest channel below the incident light. In FIG. 2B,  $n=3$ .

$$x = \left( \frac{P}{2} - \frac{V}{4} \right) + nP \quad [7]$$

This yields:

$$t = \frac{\left( \frac{P}{2} - \frac{V}{4} \right) + nP}{\tan \theta} \quad [8]$$

The total thickness of the substrate also includes the depth of the channels and half the depth of the triangular optical elements. Thus, a preferred thickness for a device including triangular optical elements and multiple channel segments can be calculated as:

$$T = t + D + \frac{\left( \frac{V}{2} \right)}{\tan \alpha} \quad [9]$$

**[0048]** Example 2 includes a description of experiments performed using a device designed in this manner.

**[0049]** FIG. 2B includes a ray trace image generated by Mathematica (Lenslab plug-in) of a proposed design of a

system including optical elements positioned above microfluidic channels. In FIG. 2B, device 310 comprises article 312 in which channels 314 and optical elements 316 are formed. Light rays 318 are directed toward surface 320 of the article, where a portion of the light is refracted through the article. The device is constructed and arranged such that the light is directed away from intervening portions 322, and toward channels 314 and ultimately detector components 324. Note that in some cases, light that is incident upon a channel does not necessarily interact with the detector at a position directly below the channel. For example, light rays 330 interact with channel 314' and detector component 324', which is not directly below (indicated by region 332) channel 314'.

[0050] It should be understood that while triangular optical elements are shown in FIGs. 1-2, a similar analysis can be performed with devices having optical elements of other shapes and configurations.

[0051] Light scattering or stray light may be reduced by fabricating the walls of these optical elements to be very smooth. In some embodiments, the root mean square (RMS) surface roughness may be, for example, less than about 1  $\mu\text{m}$ . In other embodiments, the RMS surface roughness may be less than about 0.8  $\mu\text{m}$ , less than about 0.5  $\mu\text{m}$ , less than about 0.3  $\mu\text{m}$ , or less than about 0.1  $\mu\text{m}$ . RMS surface roughness is a term known to those skilled in the art, and may be expressed as:

$$\sigma_h = \left[ \left( \frac{1}{A} \int_A (z - z_m)^2 dA \right) \right]^{1/2}$$

where A is the surface to be examined, and  $|z - z_m|$  is the local height deviation from the mean. Substantial roughness on the surface of an optical element may result in unwanted scattering or redirection of light at an undesired angle.

[0052] As described herein, optical elements may have various shapes, sizes and configurations. For example, in one set of embodiments, the largest cross-sectional dimension of an optical element is at least about 300 microns, 500 microns, 700 microns, 1 mm, 1.5 mm, 2 mm, or greater (typically, less than 1 cm). In some embodiments, the largest cross-sectional dimension of an optical element is its width. For instance, as shown in FIG. 2A, the largest cross-sectional dimension of optical element 218 is its width 224.

[0053] In some cases, e.g., as illustrated in FIG. 2A, at least one optical element (e.g., optical element 218) is positioned between first and second channel segments (e.g., segments 213 and 214, respectively), and the optical element has a largest cross-sectional dimension (e.g., width 224) greater than or equal to the width of an intervening portion positioned substantially between the first and second channel segments, but less than the combination of the widths of the two channel segments and the width of the intervening portion.

[0054] Optical elements may, in some cases, span at least about 50%, at least about 60%, at least about 70%, at least about 80%, or at least about 90% of the length of one or more channel segments on or in the article. For example, in FIG. 1B, optical elements 32 and 34 span the entire length of channel segments 26, 28, and 30.

[0055] In some fluidic devices described herein, one or more optical elements and/or channels have a non-zero draft angle. As known to those of ordinary skill in the art, a draft angle is the amount of taper, e.g., for molded or cast parts, perpendicular to the parting line. For example, as shown in FIG. 3A, a substantially rectangular channel 110, which has walls 112-A and 112-B that are substantially perpendicular to surface 114 (e.g., a parting line), has a draft angle 116 of 0°. The cross sections of fluidic channels having non-zero draft angles, on the other hand, may resemble a triangle, a parallelogram, a trapezoid, etc. For example, as shown in the embodiment illustrated in FIG. 3B, channel 120 has a substantially triangular cross-section. Draft angle 116 is formed by the angle between a line perpendicular to surface 114 and wall 127-A of the channel, and is non-zero in this embodiment.

[0056] The draft angle of an optical element, channel, or other component may be, for example, between about 1° and about 40°, between about 1° and about 30°, between about 1 and about 20°, between about 1 and about 10°, between about 2° and about 15°, between about 3° and about 10°, or between about 3° and about 8°. For instance, the draft angle may be greater than or equal to about 1°, 2°, 3°, 4°, 5°, 6°, 7°, 8°, 9°, or 10°, 20°, 37.5°, or 40°. In some cases, it is desirable for optical elements or channels to have specific draft angles so that they are compatible with a certain detection technique.

[0057] As described herein, optical elements may be combined with a fluidic device comprising one or more meandering channels. As shown in a top view of the illustrative embodiment of FIG. 3C, channel 208 includes a meandering (e.g., serpentine) region having a tightly packed channel system having a series of turns 210 and channel segments 212 that span over a large area (A) relative to the width of the channel. The area spanned by the meandering channel (i.e., the area of the meandering region) is the area bound by outermost points of the meandering channel along each axis, shown approximately in FIG. 3C by the dashed lines. This area may constitute a measurement area over which a detector may be positioned, the measurement area including both channel segments 212 and intervening channel portions 220 (i.e., non-channel segments).

[0058] FIG. 3C also shows plurality of optical elements 236 interspersed between the channel segments at the inter-

vening channel portions 220. One measurement area may include, for example, greater than or equal to 3, 5, 8, 10, 15, 20, 30, 40, or 50 optical elements. The optical elements may be the same or different from one another, and may have any suitable shape or size as described herein. Furthermore, as illustrated, a fluidic device may include optical elements that extend past the measurement area and/or past the channel segments. This configuration may allow control of light even at turns 210 of the channel segments.

**[0059]** As shown in FIG. 3C, the length of channel segments 212-A and 212-C are the same. In other embodiments, however, the lengths of the segments of the meandering channel vary within the channel. Channel segments having different lengths may result in a measurement area having different shapes. The meandering channel (and the area of the channel) can be designed to have any suitable shape, e.g., a square, rectangular, circular, oval, triangular, spiral, or an irregular shape, since in certain cases the overall shape does not affect the fluid flow conditions within the channel.

**[0060]** In FIG. 3C, the area (A) that the meandering channel spans is defined by the surface area given by dimension B times ( $\times$ ) dimension C. Typically, the area spanned by the channel (i.e., as viewed from above the channel, perpendicular to the direction of fluid flow) is on the order of millimeters squared ( $\text{mm}^2$ ). For instance, the area may be greater than or equal to  $0.5 \text{ mm}^2$ , greater than or equal to  $1 \text{ mm}^2$ , greater than or equal to  $2 \text{ mm}^2$ , greater than or equal to  $5 \text{ mm}^2$ , greater than or equal to  $10 \text{ mm}^2$ , or greater than or equal to  $50 \text{ mm}^2$ . However, in other embodiments, e.g., depending on the method used for detection, the area spanned by a meandering channel may be between  $0.25 \text{ mm}^2$  and  $0.5 \text{ mm}^2$ , or between  $0.1 \text{ mm}^2$  and  $0.25 \text{ mm}^2$ . Typically, the area spanned by the meandering channel is designed to be relatively large (e.g., on the order of  $\text{mm}^2$ ) compared to conventional microfluidic systems, so that a wide area can be used for detection and so the total amount of signal that can be detected is increased, especially in combination with one or more optical elements described herein.

**[0061]** In some embodiments, the optical elements described herein are integral to a surface of the article. As used herein, "integral" refers to a condition of being a single, unitary construction, as opposed to separate parts that are connected by other means. For instance, integral optical elements of article may be formed in a surface of the article. Integral optical elements may be either concave or convex relative to the surface on which they are formed. For example, optical elements 32 and 34 in FIGS. 1A-1B are shown as concave optical elements integral to surface 16. In some cases, such optical elements, or molds for the optical elements, are fabricated using an photolithography process, e.g., as shown in FIGs. 4A-4B and as described in more detail below.

**[0062]** As shown in various embodiments herein, one or more optical elements may be positioned substantially between two channel segments and/or one or more channel segments may be positioned substantially between two optical elements. A first object is said to be positioned "substantially between" second and third other objects when substantially all of the first object lies between the center planes of the second and third objects. As used herein, a "center plane" of an object refers to an imaginary plane that intersects the geometric center of the cross section of the object and is substantially perpendicular to the substrate in or on which the object is positioned or formed. The term "geometric center" (or "centroid") is given its normal meaning in the art. For example, in FIG. 1A, channels 26, 28, and 30 comprise center planes 26', 28', and 30', which intersect geometric centers 26", 28" and 30", respectively. In addition, optical elements 32 and 34 comprise center planes 32' and 34' which intersect geometric centers 32" and 34", respectively. Optical element 32 is positioned substantially between channels 26 and 28, and optical element 34 is positioned substantially between channels 28 and 30. Channel segment 28 is positioned substantially between optical elements 32 and 34.

**[0063]** In some embodiments, one or more optical elements of a device lie on a substantially different plane than one or more channels of the device. For example, in FIG. 1A, the plane 60 intersecting the central axes of the optical elements (positioned at the geometric centers and extending out of and into the page) does not intersect the plane 62 intersecting the central axes of the channels. In some embodiments, no line drawn between any first point on or within a first microfluidic channel segment and any second point on or within a second microfluidic channel segment intersects any point on or within an optical element. In some instances, no line drawn between any first point on or within a first optical element and any second point on or within a second optical element intersects any point on or within a microfluidic channel segment.

**[0064]** In other embodiments, however, all or a portion of an optical element lies on the same plane as one or more channel or channel segment. For instance, an optical element may be formed in or on the same surface as the channels. In another example, an optical element is formed on a side opposite a channel, but extends such that a plane perpendicular to the surface of the article passes through both the channel and the optical element. In some cases, a line drawn between a first point on or within a first channel segment and a second point on or within a second channel segment intersects a point on or within the optical element.

**[0065]** Fluidic devices described herein comprising optical elements may be optionally combined with other features (e.g., certain detection systems, lenses, etc.) for reducing the amount of stray light and/or for increasing the signal to noise ratio. FIGs. 5-10 show various examples of detection systems and results of experiments performed when such systems were used in combination with devices described herein. In some cases, however, these features may be implemented independently of the optical elements described herein.

**[0066]** In some embodiments, additional techniques may be employed that compensate for the transmission of stray

light through the microfluidic device. For example, the size (e.g., width, surface area, volume) of the intervening portions in the system may be reduced, thus reducing the percentage of light incident on the intervening portions. It should be noted that while it may not be practical to eliminate the intervening portions between the channels, as discussed in International Patent Publication No. WO2006/113727, thinner intervening portions and/or wider fluidic channels may

result in less stray light transmitted and, therefore, improved performance.  
**[0067]** The effects of reducing the size of the intervening portions on the amount of transmitted stray light can be evaluated by measuring transmission or absorbance in the system when the microchannels are filled with a perfectly absorbent fluid. Transmission through such a system is calculated as:

$$Trans = \frac{I}{I_0} \quad [10]$$

where  $I_0$  is the intensity of light transmitted with a perfectly clear (index matched) fluid in the channels, and  $I$  is the intensity of light transmitted with a perfectly absorbent fluid in the channel.

**[0068]** The optical density (OD) is a measure of absorbance in such a system, which is calculated as the negative log of transmission:

$$OD = -\log(Trans) \quad [11]$$

A system with a minimum amount of stray light transmissions results in a large OD. In theory, a measurement zone filled with a perfectly absorbent fluid and with no intervening portions and no stray light would have a transmission of 0% and very large OD. In practice, it is difficult to completely eliminate stray light in any system. A transmission measurement through an extremely absorbent fluid in a microwell (no walls, or even channels) might be 0.01%, yielding an OD of 4. In general, though, transmission measurements below 1% can be difficult to achieve. A reasonable range of ODs that may be achieved may be within the range of about 0 to about 2.

**[0069]** Assuming a perfectly absorbent fluid in the channels, the transmission through a meandering channel region (without optical elements to block or re-direct light) is simply a function of the width of the intervening portions and the width of the channel. For example, in a system with intervening portions with widths of  $x$  and channels with widths of  $y$ , the minimum transmission would be  $x/(x+y)$ . In the case of a meandering channel with identical widths for all intervening portions and channels, the value of  $x/(x+y)$  is 50% (yielding a maximum OD of 0.3). Similarly, a system with channels twice the width of the intervening portions would yield a minimum transmission of 33% (a maximum OD of 0.477). There is an upper (and lower) range for the channel widths based on the flow required in the system, since an increase in width of the channel results in an increase in cross section and changes in the properties of the channels, such as a reduction in the resistance to flow. Likewise, there is a lower range at which intervening portions can be reliably fabricated (e.g., depending on the fabrication technique). Example 3 outlines a set of experiments in which the widths of the intervening portions were varied.

**[0070]** In some embodiments, a detection system includes measuring the light transmitted through the channel portions independently of the light transmitted through the intervening portions. For example, one may image the measurement area with a digital camera, measure the intensity of light on the pixels that correspond to the channels and discard the pixels corresponding to the channel walls or the intervening portions. Optionally, lenses may be incorporated to focus the image on the plane of the channels. Such a measurement system could potentially deliver extremely high performance (avoiding stray light) and yield maximum ODs greater than about 2, e.g., OD = 2-4.

**[0071]** However, in some cases, including a camera/imaging system may result in a relatively high cost of the imaging device, relatively high cost of lenses, precision required in positioning and alignment, robustness to shock or environmental conditions, and implementation of software to identify which pixels are to be measured and which to be ignored. Accordingly, these factors may be weighed with their benefits and may be suitable for certain, but not all, applications.

**[0072]** In one embodiment, a relatively inexpensive and robust imaging system was developed for a channel system utilizing a linear image sensor. A linear image sensor is a one-dimensional array of multiple small optical detectors which can be individually measured. FIGS. 8A and 8B include schematic diagrams of exemplary imaging systems used to measure transmission through meandering channels. The optical detector 810 in FIG. 8A is a single photodiode that may image a substantial portion of the meandering channel. In FIG. 8B, on the other hand, the optical detector 812 comprises a linear image sensor that measures only portions of the meandering channel. Optionally, optical components such as a collimating lens for the light source and/or a focusing lens to transmit the image to the linear image sensor (not shown) may be utilized to improve imaging. FIG.8C includes a micrograph of a meandering channel used in one set of embodiments. A typical measurement area for a linear image sensor is indicated as region 820. In certain devices,

each optical detector of a linear image sensor can be measured individually. Such a system can be used to measure transmission through only a portion of a system. For example, a linear image sensor located under a meandering channel region as shown in FIG. 8C can be used to measure light transmission only through the channels. To do this, only the readings from detectors under the channels are recorded. Other detectors positioned under non-channel portions (e.g., intervening portions) and struck by stray light can be ignored. In this manner, linear image sensors can be used to selectively measure light transmission through channels in a meandering channel region, eliminating the problem of stray light, and yielding accurate transmission/absorbance measurements for the microfluidic system.

**[0073]** Examples of linear image sensors include the Hamamatsu S9227, a 6.4 mm long array of 512, 250-micron wide pixels at 12.5 micron spacing, the Fairchild Imaging CMOS 1421, a 14.5 mm-long array of 2048, 7-micron wide pixels with 7um center-to-center spacing, and the Panavision SVI LIS-500, a 3.9 mm long array of 500,62.5-wide pixels with 7.8um center-to-center spacing. Example 4 outlines the use of a linear image sensor in conjunction with the devices and methods described herein.

**[0074]** In some cases, the system may be designed to eliminate potential stray light before it reaches the fluidic device. For example, stray light may be eliminated by creating a light source that includes a geometry that matches the pattern of channel(s), directing light only onto the channels and away from the channel walls or intervening portions.

**[0075]** A variety of determination (e.g., measuring, quantifying, detecting, and qualifying) techniques may be used with devices described herein. Determination techniques may include optically-based techniques such as light transmission, light absorbance, light scattering, light reflection as well as luminescence techniques such as photoluminescence (e.g., fluorescence), chemiluminescence, bioluminescence, and/or electrochemiluminescence. Those of ordinary skill in the art know how to modify microfluidic devices in accordance with the determination technique used. For instance, for devices including chemiluminescent species used for determination, an opaque and/or dark background may be preferred. For determination using metal colloids, a transparent background may be preferred. Furthermore, any suitable detector may be used with devices described herein. For example, simplified optical detectors, as well as conventional spectrophotometers and optical readers (e.g., 96-well plate readers) can be used.

**[0076]** When more than one chemical and/or biological reaction (e.g., a multiplex assay) is performed on a device, the signal acquisition can be carried out by moving a detector over each analysis region. In an alternative approach, a single detector can detect signal(s) in each of the analysis regions simultaneously. In another embodiment, an analyzer can include, for example, a number of parallel optical sensors/detectors, each aligned with a analysis region and connected to the electronics of a reader. Additional examples of detectors and detection methods are described in more detail in U.S. Patent Apl. Serial No.: 12/196,392, filed August 22, 2008, entitled "Liquid containment for integrated assays", which is incorporated herein by reference.

**[0077]** As described herein, a meandering channel of an analysis region may be configured and arranged to align with a detector such that upon alignment, the detector can measure a single signal through more than one adjacent channel segments of the meandering channel. In some embodiments, the detector is able to detect a signal within at least a portion of the area of the meandering channel and through more than one segments of the meandering channel such that a first portion of the signal, measured from a first segment of the meandering channel, is similar to a second portion of the signal, measured from a second segment of the meandering channel. In such embodiments, because the signal is present as a part of more than one segment of the meandering channel, there is no need for precise alignment between a detector and an analysis region.

**[0078]** Additional examples and descriptions of detection systems are provided in the Examples section.

**[0079]** In some embodiments, the fluidic devices described herein include a reaction site in fluid communication with one or more channels or channel segments. For example, the fluidic device may comprise a reaction site comprising a binding partner (e.g., an antibody, antigen, etc.) associated with a surface of a channel segment. An entity in the fluid flowing in the channel segment may interact (e.g., bind, chemically react, etc.) with the binding partner, and the interaction may be optically detectable.

**[0080]** In one set of embodiments, a fluidic device described herein is used for performing an immunoassay. The immunoassay may be, for example, a direct immunoassay, a sandwich (e.g., 2-site) immunoassay, or a competitive immunoassay, as known to those of ordinary skill in the art. Certain devices may include a combination of one or more such immunoassays.

**[0081]** In one particular embodiment, a fluidic device is used for performing an immunoassay (e.g., for human IgG or PSA) and, optionally, uses sliver enhancement for signal amplification. A device described herein may have one or more similar characteristics as those described in U.S. Patent Application Serial No. 12/113,503, filed May 1, 2008 and entitled "Fluidic Connectors and Microfluidic Systems", which is incorporated herein by reference. In such an immunoassay, after delivery of a sample containing human IgG to a reaction area or analysis region, binding between the human IgG and anti-human IgG can take place. One or more reagents, which may be optionally stored in the device prior to use, can then flow over this binding pair complex. One of the stored reagents may include a solution of metal colloid (e.g., a gold conjugated antibody) that specifically binds to the antigen to be detected (e.g., human IgG). This metal colloid can provide a catalytic surface for the deposition of an opaque material, such as a layer of metal (e.g., silver), on a surface

of the analysis region. The layer of metal can be formed by using a two component system: a metal precursor (e.g., a solution of silver salts) and a reducing agent (e.g., hydroquinone), which can optionally be stored in different channels prior to use.

5 **[0082]** As a positive or negative pressure differential is applied to the system, the silver salt and hydroquinone solutions can merge at a channel intersection, where they mix (e.g., due to diffusion) in a channel, and then flow over the analysis region. Therefore, if antibody-antigen binding occurs in the analysis region, the flowing of the metal precursor solution through the region can result in the formation of an opaque layer, such as a silver layer, due to the presence of the catalytic metal colloid associated with the antibody-antigen complex. The opaque layer may include a substance that interferes with the transmittance of light at one or more wavelengths. Any opaque layer that is formed in the microfluidic channel can be detected optically, for example, by measuring a reduction in light transmittance through a portion of the analysis region (e.g., a meandering channel region) compared to a portion of an area that does not include the antibody or antigen. Alternatively, a signal can be obtained by measuring the variation of light transmittance as a function of time, as the film is being formed in a analysis region. The opaque layer may provide an increase in assay sensitivity when compared to techniques that do not form an opaque layer. Additionally, various amplification chemistries that produce optical signals (e.g., absorbance, fluorescence, glow or flash chemiluminescence, electrochemiluminescence), electrical signals (e.g., resistance or conductivity of metal structures created by an electroless process) or magnetic signals (e.g., magnetic beads) can be used to allow detection of a signal by a detector.

10 **[0083]** It should be understood that devices described herein may be used for any suitable chemical and/or biological reaction, and may include, for example, other solid-phase assays that involve affinity reaction between proteins or other biomolecules (e.g., DNA, RNA, carbohydrates), or non-naturally occurring molecules. In some embodiments, a chemical and/or biological reaction involves binding. Different types of binding may take place in devices described herein. The term "binding" refers to the interaction between a corresponding pair of molecules that exhibit mutual affinity or binding capacity, typically specific or non-specific binding or interaction, including biochemical, physiological, and/or pharmaceutical interactions. Biological binding defines a type of interaction that occurs between pairs of molecules including proteins, nucleic acids, glycoproteins, carbohydrates, hormones and the like. Specific examples include antibody/antigen, antibody/hapten, enzyme/substrate, enzyme/inhibitor, enzyme/cofactor, binding protein/substrate, carrier protein/substrate, lectin/carbohydrate, receptor/hormone, receptor/effector, complementary strands of nucleic acid, protein/nucleic acid repressor/inducer, ligand/cell surface receptor, virus/ligand, etc. Binding may also occur between proteins or other components and cells. In addition, devices described herein may be used for other fluid analyses (which may or may not involve binding and/or reactions) such as detection of components, concentration, etc.

15 **[0084]** Non-limiting examples of analytes that can be determined using fluidic devices described herein include specific proteins, viruses, hormones, drugs, nucleic acids and polysaccharides; specifically antibodies, e.g., IgD, IgG, IgM or IgA immunoglobulins to HTLV-I, HIV, Hepatitis A, B and non A/non B, Rubella, Measles, Human Parvovirus B 19, Mumps, Malaria, Chicken Pox or Leukemia; human and animal hormones, e.g., thyroid stimulating hormone (TSH), thyroxine (T4), luteinizing hormone (LH), follicle-stimulating hormones (FSH), testosterone, progesterone, human chorionic gonadotropin, estradiol; other proteins or peptides, e.g. troponin I, c-reactive protein, myoglobin, brain natriuretic protein, prostate specific antigen (PSA), free-PSA, complexed-PSA, pro-PSA, EPCA-2, PCADM-1, ABCA5, hK2, beta-MSP (PSP94), AZGP1, Annexin A3, PSCA, PSMA, JM27, PAP; drugs, e.g., paracetamol or theophylline; marker nucleic acids, e.g., PCA3, TMPRS-ERG; polysaccharides such as cell surface antigens for HLA tissue typing and bacterial cell wall material. Chemicals that may be detected include explosives such as TNT, nerve agents, and environmentally hazardous compounds such as polychlorinated biphenyls (PCBs), dioxins, hydrocarbons and MTBE. Typical sample fluids include physiological fluids such as human or animal whole blood, blood serum, blood plasma, semen, tears, urine, sweat, saliva, cerebro-spinal fluid, vaginal secretions; in-vitro fluids used in research or environmental fluids such as aqueous liquids suspected of being contaminated by the analyte. In some embodiments, one or more of the above-mentioned reagents is stored in a channel or chamber of a fluidic device prior to first use in order to perform a specific test or assay.

20 **[0085]** Some embodiments of the invention are in the form of a kit that may include, for example, a microfluidic system, a source for promoting fluid flow (e.g., a vacuum), and/or one, several, or all the reagents necessary to perform an analysis except for the sample to be tested. In some embodiments, the microfluidic system of the kit may have a configuration similar to one or more of those shown in the figures and/or as described herein. The fluidic device of the kit may be portable and may have dimensions suitable for use in point-of-care settings.

25 **[0086]** The kit may include reagents and/or fluids that may be provided in any suitable form, for example, as liquid solutions or as dried powders. In some embodiments, a reagent is stored in the microfluidic system prior to first use, as described in more detail herein. When the reagents are provided as a dry powder, the reagent may be reconstituted by the addition of a suitable solvent, which may also be provided. In embodiments where liquid forms of the reagent are provided, the liquid form may be concentrated or ready to use. The fluids may be provided as specific volumes (or may include instructions for forming solutions having a specific volume) to be flowed in the microfluidic system.

30 **[0087]** The kit may be designed to perform a particular analysis such as the determination of a specific disease

condition. For instance, markers (e.g., PSA) for specific diseases (e.g., prostate cancer) may be included (e.g., stored) in a device or kit in a fluid or dry form prior to first use of the device/kit. In order to perform a particular analysis or test using the kit, the fluidic device may be designed to have certain geometries, and the particular compositions, volumes, and viscosities of fluids may be chosen so as to provide optimal conditions for performing the analysis in the system.

For example, if a reaction to be performed at an analysis region requires the flow of an amplification reagent over the analysis region for a specific, pre-calculated amount of time in order to produce an optimal signal, the fluidic device may be designed to include a channel segment having a particular cross-sectional area and length to be used with a fluid of specific volume and viscosity in order to regulate fluid flow in a predetermined and pre-calculated manner. Washing solutions and buffers may also be included. The device may optionally include one or more reagents stored therein prior to first use. Furthermore, the kit may include a device or component for promoting fluid flow, such as a source of vacuum dimensioned to be connected to an outlet. The device or component may include one or more pre-set values so as to create a known (and optionally constant) pressure drop between an inlet and an outlet of the fluidic device. Thus, the kit can allow one or more reagents to flow for a known, pre-calculated amount of time at an analysis region, or at other regions of the system, during use. Those of ordinary skill in the art can calculate and determine the parameters necessary to regulate fluid flow using general knowledge in the art in combination with the description provided herein.

**[0088]** A kit described herein may further include a set of instructions for use of the kit. The instructions can define a component of instructional utility (e.g., directions, guides, warnings, labels, notes, FAQs ("frequently asked questions"), etc., and typically involve written instructions on or associated with the components and/or with the packaging of the components for use of the microfluidic system. Instructions can also include instructional communications in any form (e.g., oral, electronic, digital, optical, visual, etc.), provided in any manner such that a user will clearly recognize that the instructions are to be associated with the components of the kit.

**[0089]** In some embodiments, microfluidic systems described herein contain stored reagents prior to first use of the device and/or prior to introduction of a sample into the device. In some cases, one or both of liquid and dry reagents may be stored on a single article. Additionally or alternatively, the reagents may also be stored in separate vessels such that a reagent is not in fluid communication with the microfluidic system prior to first use. The use of stored reagents can simplify use of the microfluidic system by a user, since this minimizes the number of steps the user has to perform in order to operate the device. This simplicity can allow microfluidic systems described herein to be used by untrained users, such as those in point-of-care settings, and in particular, for devices designed to perform immunoassays. It has been demonstrated previously that the storage of the reagents in the form of liquid plugs separated by air gaps were stable for extended periods of time (see, for example, International Patent Publication No. WO2005/072858 (International Patent Application Serial No. PCT/US2005/003514), filed January 26, 2005 and entitled "Fluid Delivery System and Method," which is incorporated herein by reference in its entirety). Fluidic devices for storing reagents may also include a configuration as described in U.S. Patent Appl. Serial No. 12/640,420 filed on December 17, 2009 and entitled, "Improved Reagent Storage in Microfluidic Systems and Related Articles and Methods," which is incorporated herein by reference in its entirety. In other embodiments, however, microfluidic devices described herein do not contain stored reagents prior to first use of the device and/or prior to introduction of a sample into the device.

**[0090]** As used herein, "prior to first use" of the device means a time or times before the device is first used by an intended user after commercial sale. First use may include any step(s) requiring manipulation of the device by a user. For example, first use may involve one or more steps such as puncturing a sealed inlet to introduce a reagent into the device, connecting two or more channels to cause fluid communication between the channels, preparation of the device (e.g., loading of reagents into the device) before analysis of a sample, loading of a sample onto the device, preparation of a sample in a region of the device, performing a reaction with a sample, detection of a sample, etc. First use, in this context, does not include manufacture or other preparatory or quality control steps taken by the manufacturer of the device. Those of ordinary skill in the art are well aware of the meaning of first use in this context, and will be able easily to determine whether a device of the invention has or has not experienced first use. In one set of embodiments, devices of the invention are disposable after first use, and it is particularly evident when such devices are first used, because it is typically impractical to use the devices at all after first use.

**[0091]** The devices described herein may comprise one or more channels or channel segments. A "channel" or "channel portion", as used herein, means a feature on or in an article or substrate (e.g., formed in a surface/side of an article or substrate) that at least partially directs the flow of a fluid. A channel, channel portion, or channel segment, etc. can have any cross-sectional shape (circular, oval, triangular, irregular, square or rectangular, trapezoidal, or the like) and can be covered or uncovered. In embodiments where it is covered, at least one portion of the channel can have a cross-section that is substantially enclosed, or the entire channel may be substantially enclosed along its entire length with the exception of its inlet(s) and outlet(s). In some cases, the inlet and/or outlet may also be enclosed or sealed, e.g., to prevent fluids and/or other reagents from being removed from the device (e.g., due to evaporation).

**[0092]** A channel, channel segment, channel portion, etc., may also have an aspect ratio (length to average cross-sectional dimension) of at least 2:1, more typically at least 3:1, 5:1, or 10:1 or more. In some embodiments, one or more channels, channel segments, channel portions, intervening channels, etc., is microfluidic. "Microfluidic," as used herein,

refers to a device, apparatus or system including at least one fluid channel having a cross-sectional dimension of less than 1 mm, and a ratio of length to largest cross-sectional dimension of at least 3:1. A "microfluidic channel" or "microfluidic channel segment" as used herein, is a channel meeting these criteria. Though in some embodiments, devices of the invention may be microfluidic, in certain embodiments, the invention is not limited to microfluidic systems and may relate to other types of fluidic systems. Furthermore, it should be understood that all or a majority of the channels described herein may be microfluidic in certain embodiments. The "cross-sectional dimension" (e.g., a diameter, a height, and/or a width) of a channel, channel segment, channel portion, or intervening channel, etc. is measured perpendicular to the direction of fluid flow. In one set of embodiments, the maximum cross-sectional dimension of one or more channels or channel segments containing embodiments described herein are less than about 750 microns, less than about 500 microns, less than about 300 microns, less than about 200 microns, less than about 100 microns, less than about 50 microns, less than about 25 microns, less than about 10 microns, or less than about 5 microns. In some cases, at least two cross-sectional dimensions (e.g., a height and a width) of a channel, channel segment, or channel portion have one or more of the dimensions listed above (e.g., a width of less than 500 microns and a height of less than 200 microns).

**[0093]** One or more channels or channel segments described herein may have any suitable length. In some cases, the channels or channel segments may be at least about 1 mm long, at least about 2 mm long, at least about 5 mm long, at least about 10 mm long, at least about 20 mm long, at least about 50 mm long, or longer.

**[0094]** The channels or channel segments may also be spaced any suitable distance apart from each other. For example, in some cases, the width of one or more intervening portions between channels or channel segments may be less than about 5 mm, less than about 2 mm, less than about 1 mm, less than about 500 microns, less than about 300 microns, less than about 200 microns, less than about 100 microns, less than about 50 microns, less than about 25 microns, less than about 10 microns, less than about 5 microns, or less. In certain embodiments, channel segments may be separated by a distance of less than 0.01 times, less than 0.1 times, less than 0.25 times, less than 0.5 times, less than 1 times, less than 2 times, less than 5 times, or less than 10 times the average largest width of the channel segment.

**[0095]** The channels or channel segments may also be oriented in any suitable manner. In some instances, all channels or channel segments are spaced a substantially equal distance from each other (i.e., the widths of the intervening portions are all substantially the same). The channels or channel segments may also be oriented such that two or more (e.g., all) are substantially parallel to each other.

**[0096]** In some cases the dimensions of a channel may be chosen such that fluid is able to freely flow through the article or substrate. The dimensions of the channel may also be chosen, for example, to allow a certain volumetric or linear flowrate of fluid in the channel. Of course, the number of channels and the shape of the channels can be varied by any method known to those of ordinary skill in the art. In some cases, more than one channel or capillary may be used.

**[0097]** In some embodiments described herein, microfluidic systems include only a single interconnected channel with, for example, less than 5, 4, 3, 2, or 1 channel intersection(s) when in use. A layout based on a single channel with minimal or no intersections may be reliable because there is only one possible flow path for any fluid to travel across the microfluidic chip.

**[0098]** A microfluidic system described herein may have any suitable volume for carrying out a chemical and/or biological reaction or other process. The entire volume of a microfluidic system includes, for example, any reagent storage areas, reaction areas, liquid containment regions, waste areas, as well as any fluid connectors, and microfluidic channels associated therewith. In some embodiments, small amounts of reagents and samples are used and the entire volume of the microfluidic system is, for example, less than 10 milliliters, less than 5 milliliters, less than 1 milliliter, less than 500 microliters, less than 250 microliters, less than 100 microliters, less than 50 microliters, less than 25 microliters, less than 10 microliters, less than 5 microliters, or less than 1 microliter.

**[0099]** A fluidic device and/or an article described herein may be portable and, in some embodiments, handheld. The length and/or width of the device and/or article may be, for example, less than or equal to 20 cm, 15 cm, 10 cm, 8 cm, 6 cm, or 5 cm. The thickness of the device and/or article may be, for example, less than or equal to 5 cm, 3 cm, 2 cm, 1 cm, 8 mm, 5 mm, 3 mm, 2 mm, or 1 mm. Advantageously, portable devices may be suitable for use in point-of-care settings.

**[0100]** All or a portion of a fluidic device such as an article or a cover can be fabricated of any suitable material. For example, articles that include channels may be formed of a suitable material for forming a microchannel. Non-limiting examples of materials include polymers (e.g., polyethylene, polystyrene, polymethylmethacrylate, polycarbonate, poly(dimethylsiloxane), PTFE, PET, and a cyclo-olefin copolymer), glass, quartz, and silicon. The article and/or cover may be hard or flexible. Those of ordinary skill in the art can readily select a suitable material based upon e.g., its rigidity, its inertness to (e.g., freedom from degradation by) a fluid to be passed through it, its robustness at a temperature at which a particular device is to be used, its transparency/opacity to light (e.g., in the ultraviolet and visible regions), and/or the method used to fabricate features in the material. For instance, for injection molded or other extruded articles, the material used may include a thermoplastic (e.g., polypropylene, polycarbonate, chlorotrifluoroethylene, acrylonitrile-butadiene-styrene, nylon 6), an elastomer (e.g., polyisoprene, isobutene-isoprene, nitrile, neoprene, ethylene-propylene, hypalon, silicone), a thermoset (e.g., epoxy, unsaturated polyesters, phenolics), or combinations thereof. In some embodiments, the material

and dimensions (e.g., thickness) of an article and/or cover are chosen such that it is substantially impermeable to water vapor. For instance, a fluidic device designed to store one or more fluids therein prior to first use may include a cover comprising a material known to provide a high vapor barrier, such as metal foil, certain polymers, certain ceramics and combinations thereof. In other cases, the material is chosen based at least in part on the shape and/or configuration of the device. For instance, certain materials can be used to form planar devices whereas other materials are more suitable for forming devices that are curved or irregularly shaped.

**[0101]** In some instances, a fluidic device is formed of a combination of two or more materials, such as the ones listed above. For instance, the channels of the device may be formed in a first material (e.g., poly(dimethylsiloxane)), and a cover that is formed in a second material (e.g., polystyrene) may be used to seal the channels. In another embodiment, a first set of channels is formed in a first article comprising a first material and a second set of channels is formed in a second article comprising a second material. In yet another embodiment, channels of the device may be formed in polystyrene or other polymers (e.g., by injection molding) and a biocompatible tape may be used to seal the channels. The biocompatible tape may include a material known to improve vapor barrier properties (e.g., metal foil, polymers or other materials known to have high vapor barriers). A variety of methods can be used to seal a microfluidic channel or portions of a channel, or to join multiple layers of a device, including but not limited to, the use of adhesives (such as acrylic or silicone based adhesives), use adhesive tapes, gluing, bonding, lamination of materials, or by mechanical methods (e.g., clamping).

**[0102]** Sealing a channel and/or any inlets and outlets may protect and retain any gases, liquids, and/or dry reagents that may be stored within a channel. In addition or alternatively to one or more covers described herein, in certain embodiments, a fluid having low volatility, such as an oil or glycol may be placed in the end of a tube to help prevent evaporation and/or movement of other fluids contained therein.

**[0103]** Devices comprising optical elements and channels (e.g., microchannels) described herein may be fabricated using a variety of techniques. For example, the devices described herein may be formed using injection molding, hot embossing, or other plastic engineering techniques. The devices may also be manufactured using traditional machining techniques. In some cases, the devices may be fabricated by producing a mold and transferring the features of the mold to a hardenable polymer (e.g., PDMS). Molds may be fabricated by, for example, etching features into a silicon wafer (e.g., via an anisotropic KOH etch) and transferring the features onto a hardenable material (e.g., SU-8) which may then serve as a mold. In some cases, the microfluidic devices described herein include an article that is a single, integral piece of material without joined layers.

**[0104]** In one set of embodiments, purely photolithographic techniques are used to fabricate the channels and optical elements in a polymer. FIGS. 4A-4B illustrate a fabrication process that may be used to produce triangular optical elements in photoresist. In FIG. 4A, a layer of photoresist 410 overlies substrate 412. Photomask 414, comprising UV-transparent feature 416, is exposed to ultraviolet light 418. The ultraviolet light is directed at an angle 420 from the normal of the photomask. The development of the photoresist layer results in the formation of a triangular feature 430, as shown in FIG. 4B. This technique may produce features having smooth surfaces. In addition, the technique may be used to fabricate features with a relatively wide range of draft angles (e.g., from about 0° to about 20°). Such methods are known to those of ordinary skill in the art.

**[0105]** The manufacturing processes used to produce devices by injection molding (or other plastic engineering techniques, such as hot embossing), often require molds having non-zero draft angles on some or all of the features to be replicated in plastic. As discussed above, a draft angle is the amount of taper for molded or cast parts perpendicular to the parting line (a square channel with walls perpendicular to the floor having a draft angle of zero degrees). A non-zero draft angle is often necessary to allow demolding of the replica from the molding tool.

**[0106]** The fabrication of elements with non-zero draft angles is challenging. For instance, for microfluidic structures (e.g., channels) having various depths, the corresponding mold must have features with multiple heights in addition to non-zero draft angles. These types of molds can be challenging to fabricate on the microscale, as molding microchannels in plastic with constrictions in draft angle, depth, as well as in width is not trivial.

**[0107]** In fact, few techniques can yield the appropriate shapes for a mold having non-zero draft angles. To widen the breadth of technologies able to produce the appropriate shapes, an indirect route to the fabrication of the mold can be chosen. For instance, the channels themselves can be created in various materials, by various techniques to produce a master. The negative shape of the master is then obtained (e.g., by electrodeposition), resulting in a mold for injection molding. The techniques capable of yielding a master with non-zero draft angles and various depths include: (1) milling with one or more trapezoidal-shaped bits, (2) photolithographic techniques in combination with thick photosensitive polymers, for instance photosensitive glass or photoresist like SU8, in combination with a back-side exposure or a top-side exposure with light with a non-normal angle. An example of the use of non-normal top-side exposure with photosensitive glass to produce features with non-zero draft angles is described in US Patent No. 4,444,616. The preparation of multiple depths can be achieved by multiple photolithographic exposures onto multiple layers of photosensitive material. (3) KOH etching on silicon substrates can also produce non-zero draft angles, according to the crystalline planes of the silicon. (4) Alternative to straight draft angles, channels having rounded side-walls can also produce suitable master for

molds. Such rounded side-walls can be achieved by isotropic etching onto planar surface (e.g., HF etching on Pyrex wafers), or by reflowing structures photoresist by heat treatment. (5) Deep Reactive Ion Etching (DRIE) can also produce non-zero degree draft angles under certain parameters.

[0108] The following examples are intended to illustrate certain embodiments of the present invention, but are not to be construed as limiting and do not exemplify the full scope of the invention.

### Example 1

#### Fabrication of Microfluidic Channels

[0109] A method for fabricating a microfluidic channel system is described.

[0110] Channel systems, such as the ones shown in FIG. 1A and 1B, were designed with a computer-aided design (CAD) program. The microfluidic devices were formed in poly(dimethylsiloxane) Sylgard 184 (PDMS, Dow Corning, Ellsworth, Germantown, WI) by rapid prototyping using masters made in SU8 photoresist (MicroChem, Newton, MA). The masters were produced on a silicon wafer and were used to replicate the negative pattern in PDMS. The masters contained two levels of SU8, one level with a thickness (height) of ~70  $\mu\text{m}$  defining the channels in the immunoassay area, and a second thickness (height) of ~360  $\mu\text{m}$  defining the reagent storage and waste areas. Another master was designed with channel having a thickness (height) of 33  $\mu\text{m}$ . The masters were silanized with (tridecafluoro-1,1,2,2-tetrahydrooctyl)trichlorosilane (ABC-R, Germany). PDMS was mixed according to the manufacturer's instructions and poured onto the masters. After polymerization (4 hours, 65°C), the PDMS replica was peeled off the masters and access ports were punched out of the PDMS using stainless steel tubing with sharpened edges (1.5 mm in diameter). To complete the fluidic network, a flat substrate such as a glass slide, silicon wafer, polystyrene surface, flat slab of PDMS, or an adhesive tape was used as a cover and placed against the PDMS surface. The cover was held in place either by van der Waals forces, or fixed to the microfluidic device using an adhesive.

[0111] In other embodiments, the microfluidic channels were made in polystyrene or other thermoplastics by injection molding. This method is known to those of ordinary skill in the art. The volume of an injection molding cavity can be defined by a bottom surface and a top surface separated by a hollow frame which determines the thickness of the molded article. For an article including channel features and or other microscale elements on two opposing sides of the article, the bottom and top surfaces of the molding cavity may include raised features that create the channel features on either side of the article. For an article including channel features on only one side of the article, only the top or bottom surface of the molding cavity includes such features. Thru-holes that pass through the entire thickness of the article can be produced by pins traversing the cavity, embedded in one or more surfaces of the cavity and contacting the other side. For instance, the pins may extend from only the top surface, only the bottom surface, or from both the top and bottom surfaces.

### Example 2

#### Performance of a System Comprising Triangular Optical Elements

[0112] This example describes the transmission profiles of systems employing a meandering channel, one with triangular optical elements (grooves) and another without. An article was fabricated in polystyrene with identical systems of fluidic channels on one side. Some of these channels included triangular optical elements between the channels on the other side (shielded channels). Other channels did not include triangular optical elements between them (normal/standard channels with no shielding). The channels were 160 microns in width. Intervening portions between the channels were 60 microns in width. The article thickness was designed using the model described above. Triangular optical elements were also designed as described in the model above with an angle of 35.3°, a width of 160 microns, and a pitch of 220 microns. Optical measurements were performed using a single collimated LED light source and a single photodiode detector.

[0113] Measurements were performed with an approximate index-matching liquid in the channels (water) and with a concentrated absorbing dye (Methylene Blue, 20mg/ml in water). Using water in the "normal" channel (channel without optical elements) as the baseline, the following transmission measurements were made:

	Transmission	OD
Water in Normal Channel	100%	0.00
Dye in Normal Channel	27%	0.56
Water Shielded Channel	26%	0.58

(continued)

	Transmission	OD
Dye in Shielded Channel	1%	1.98

Assuming a perfectly absorbing dye, the transmission through normal channels should be 27%, since the channel walls make up  $60/(60+160) = 27\%$  of the area of the measurement zone. Experimental results confirmed this prediction. Note that the range of ODs provided by a non-shielded channel of these dimensions would be 0 to 0.56. In shielded channels with dye, only 1% of the incident light was transmitted. The triangular optical element was designed to either block light that would be transmitted through the intervening portions or directed the light into the channels. The dye in the channels absorbed most, if not all, the light striking the channels.

**[0114]** With water in the shielded channels, 26% of the light incident on the measurement zone was transmitted. With a width 60 microns and a pitch of 220 microns, the triangular optical elements blocked 73% of the top surface of the measurement area. The remaining 27% of the area was positioned directly above channels. Since these channels were filled with index matching liquid, it was assumed that they transmitted all of the light striking them. A total transmission of 26% indicated that, in this particular experiment, significantly more of the light incident on the optical elements was reflected out of the system than was directed to the channels.

**[0115]** To understand the measurement range of the shielded channels, a comparison was made between the intensity of light transmitted through the shielded channels with dye and the intensity of light transmitted through the shielded channels with water. Using the shielded channels with water as a baseline, the transmission with dye was 4%. This indicated that the range of ODs provided by the shielded system with channels of these dimensions would be 0 to 1.40. This represents a significant improvement over the normal configuration. FIG. 5 presents a comparison of ODs measured in shielded meandering channels and ODs measured in unshielded meandering channels. In this example, erioglaucine dye was used. As can be seen, the shielding delivered a larger dynamic range of ODs corresponding to superior performance.

**[0116]** A more detailed comparison of transmitted light can be obtained using the linear image sensor system described above. FIG. 6A includes a schematic diagram outlining light transmission through a microfluidic meandering channel measurement zone without optical elements. In this set of experiments, the channels were filled with dark dye (10 mg/mL erioglaucine dye). A collimated light source was used to shine incident light onto the meandering channel measurement zone. A focusing lens and a linear image sensor was used to detect light through the measurement zone. The light incident upon the channels was absorbed by the dye, while the light incident between the channels passed through the article. FIG. 6B is a plot of the transmitted light as a function of position across the measurement zone. The peaks in FIG. 6B indicate the presence of a large amount of stray light between the channels.

**[0117]** FIG. 6C includes a schematic diagram outlining light transmission through a microfluidic meandering channel measurement zone with optical elements. As in the previous set of experiments, the channels were filled with dye, which absorbed light incident upon the channels. FIG. 6D, like FIG. 6B, includes a plot of transmitted light as a function of position across the measurement zone. However, in this instance, the peaks corresponding to the positions between the channels have been reduced dramatically, meaning stray light between the channel reduced due to the presence of the optical elements. Due to the shielding provided by the optical elements, when they are employed, a single photosensor may provide nearly equivalent optical performance compared to a more complex linear image sensor. This shows that simplified optical systems can be used in combination with fluidic devices described herein.

### Example 3

#### Reducing the Width of Intervening Portions

**[0118]** In this example, several samples with various widths of intervening portions were fabricated and tested. FIG. 7A includes a micrograph and a schematic illustration of a device comprising 120-micron-wide optical elements spaced 100 microns apart. In FIG. 7B, the optical elements are spaced only 30 microns apart. The channels were filled with dye (Erioglaucine) at various concentrations, and measurements of transmissions through the meandering channel region were taken. FIG. 7C includes a plot of the net OD as a function of the dye concentration for several devices including varied inter-element spacings. As can be seen from the plot, the OD increases with an increase in dye concentration and a decrease in inter-element spacing. Table 1 summarizes the theoretical maximum projected optical density (minimum transmission) and actual optical performance of these systems.

**Table 1.** Predicted and measured maximum optical densities for various devices.

Channel width	Width of Intervening Portions	Predicted Max OD	Measured Max OD
120 $\mu$ m	50 $\mu$ m	0.53	0.49
120 $\mu$ m	60 $\mu$ m	0.48	0.43
120 $\mu$ m	70 $\mu$ m	0.43	0.38
120 $\mu$ m	80 $\mu$ m	0.40	0.35
120 $\mu$ m	90 $\mu$ m	0.37	0.32
120 $\mu$ m	100 $\mu$ m	0.34	0.30

#### Example 4

##### Use of Linear Image Sensors

**[0119]** This example describes the use of a linear image sensor in conjunction with the systems and methods described herein.

**[0120]** A linear image sensor was positioned underneath a meandering channel as shown in FIG. 8B such that detection elements were positioned below the surface including the channel. A focusing lens was mounted between the sensor and the meandering channel so that a focused image of the channel was projected onto the sensor surface. Collimated light was used to illuminate the meandering channel. In an alternative experimental setup, the linear image sensor was placed immediately underneath the meandering channel (i.e., within less than 0.5 mm), alleviating the need for a lens to be placed between the meandering channel and the surface of the optical detector.

**[0121]** Measurements of the system were performed with various fluids in the channel including index-matching liquid, dye diluted in water, and concentrated dye. FIGS. 9A-9D include plots of transmitted light as a function of position along the linear image sensor for various dye concentrations. In FIG 9A, a low dye concentration (0.05mg/mL erioglaucine) was used in the channel. FIGS 9B-9D show dye concentrations of 0.4mg/mL, 1.6mg/mL, and 50mg/mL respectively. Less light was transmitted through the channels (i.e., absorbance increased) as the dye concentration increased. A software program was written to identify which pixels corresponded to positions within the channel. Selecting only these pixels, transmission was calculated as:

$$T = \frac{\text{Intensity of light detected with target liquid channel}}{\text{Intensity of light detected with index matching liquid in channel}} \quad [12]$$

A total transmission value was calculated by averaging the measurements from all the identified channel pixels.

**[0122]** Various concentrations of dyes were imaged in the channels (corresponding to various levels of absorption in the channels). Transmissions were calculated using the method explained above and converted into ODs. FIG. 10 includes plots of OD as a function of dye concentration when using a single photodetector (measuring the light traveling throughout the channels and between the channels) and when using a linear image sensor (discriminating pixels). The linear image sensor delivered a larger dynamic range of ODs corresponding to superior performance.

**[0123]** While several embodiments of the present invention have been described and illustrated herein, those of ordinary skill in the art will readily envision a variety of other means and/or structures for performing the functions and/or obtaining the results and/or one or more of the advantages described herein, and each of such variations and/or modifications is deemed to be within the scope of the present invention. More generally, those skilled in the art will readily appreciate that all parameters, dimensions, materials, and configurations described herein are meant to be exemplary and that the actual parameters, dimensions, materials, and/or configurations will depend upon the specific application or applications for which the teachings of the present invention is/are used. Those skilled in the art will recognize, or be able to ascertain using no more than routine experimentation, many equivalents to the specific embodiments of the invention described herein. It is, therefore, to be understood that the foregoing embodiments are presented by way of example only and that, within the scope of the appended claims and equivalents thereto, the invention may be practiced otherwise than as specifically described and claimed. The present invention is directed to each individual feature, system, article, material, kit, and/or method described herein. In addition, any combination of two or more such features, systems, articles, materials, kits, and/or methods, if such features, systems, articles, materials, kits, and/or methods are not mutually inconsistent, is included within the scope of the present invention.

**[0124]** All definitions, as defined and used herein, should be understood to control over dictionary definitions, definitions

in documents incorporated by reference, and/or ordinary meanings of the defined terms.

[0125] The indefinite articles "a" and "an," as used herein in the specification and in the claims, unless clearly indicated to the contrary, should be understood to mean "at least one."

5 [0126] It should also be understood that, unless clearly indicated to the contrary, in any methods claimed herein that include more than one step or act, the order of the steps or acts of the method is not necessarily limited to the order in which the steps or acts of the method are recited.

[0127] In the claims, as well as in the specification above, all transitional phrases such as "comprising," "including," "carrying," "having," "containing," "involving," "holding," "composed of," and the like are to be understood to be openended, i.e., to mean including but not limited to. Only the transitional phrases "consisting of" and "consisting essentially of" shall 10 be closed or semi-closed transitional phrases, respectively, as set forth in the United States Patent Office Manual of Patent Examining Procedures, Section 2111.03.

**Items pertaining to the Invention and the Disclosure**

15 [0128]

1. A fluidic device comprising:

20 an article including first and second opposing sides;  
 first and second microfluidic channel segments, each integral to the first side of the article;  
 an intervening portion positioned substantially between the first and second microfluidic channel segments; and  
 a first optical element integral to the second side of the article and positioned Substantially between the first  
 and second channel segments and opposite the intervening portion,  
 wherein the first optical element is adapted and arranged such that when a portion of the article is exposed to  
 25 light at a first intensity, the first optical element redirects at least a portion of the light away from the intervening  
 portion, such that the intervening portion is not exposed to the light or is exposed to the light at a second intensity  
 lower than an intensity of the light at the intervening portion absent the first optical element.

30 2. A fluidic device comprising:

an article comprising first and second sides;  
 a first microfluidic channel segment integral to the first side of the article;  
 first and second optical elements, each integral to the second side of the article,  
 wherein the first microfluidic channel segment is positioned substantially between the first and second optical  
 35 elements;  
 a cover positioned over the first microfluidic channel segment so as to substantially enclose the first microfluidic  
 channel segment; and  
 an intervening surface portion at the second side of the article positioned substantially between the first and  
 second optical elements, the intervening surface portion being substantially parallel to a surface portion of the  
 40 cover that substantially encloses the first microfluidic channel segment.

3. A fluidic device comprising:

45 an article comprising first and second sides;  
 first and second microfluidic channel segments, each integral to the first side of the article; and  
 a first substantially triangular optical element integral to the second side of the article and positioned substantially  
 between the first and second channel segments.

50 4. A fluidic device as in any one of the preceding items, wherein the optical element is integral to a surface of the article.

5. A fluidic device as in any one of the preceding items, comprising a plurality of microfluidic channel segments.

6. A fluidic device as in any one of the preceding items, comprising a plurality of optical elements.

55 7. A fluidic device as in any one of the preceding items, comprising a plurality of intervening portions.

8. A fluidic device as in any one of the preceding items, wherein one or more optical elements are substantially  
 triangular.

9. A fluidic device as in any one of the preceding items, wherein one or more optical elements are concave.

10. A fluidic device as in any one of the preceding items, wherein one or more optical elements are convex.

5 11. A fluidic device as in any one of the preceding items, wherein no line drawn between any first point on or within the first microfluidic channel segment and any second point on or within the second microfluidic channel segment intersects any point on or within an optical element.

10 12. A fluidic device as in any one of the preceding items, wherein no line drawn between any first point on or within the first optical element and any second point on or within the second optical element intersects any point on or within a microfluidic channel segment.

13. A fluidic device as in any one of the preceding items, wherein the first side is a first surface of the article.

15 14. A fluidic device as in any one of the preceding items, wherein the second side is a second surface of the article.

15. A fluidic device as in any one of the preceding items, wherein one or more optical elements comprises a cross-sectional dimension of at least about 50 microns.

20 16. A fluidic device as in any one of the preceding items, wherein redirecting light comprises refracting light.

17. A fluidic device as in any one of the preceding items, wherein redirecting light comprises reflecting light.

25 18. A fluidic device as in any one of the preceding items, wherein at least one optical element comprises a substantially opaque material.

19. A fluidic device as in any one of the preceding items, wherein at least one optical element comprises a reflective surface.

30 20. A fluidic device as in any one of the preceding items, wherein at least one optical element comprises an open channel.

35 21. A fluidic device as in any one of the preceding items, wherein at least one optical element comprises a substantially enclosed channel.

22. A fluidic device as in any one of the preceding items, wherein at least one optical element comprises a fluid.

23. A fluidic device as in any one of the preceding items, wherein the fluid comprises a dye.

40 24. A fluidic device as in any one of the preceding items, wherein at least one optical element has a draft angle between about 12° and about 60°.

45 25. A fluidic device as in any one of the preceding items, wherein at least one optical element has a draft angle between about 30° and about 40°.

26. A fluidic device as in any one of the preceding items, wherein at least one optical element is adapted and arranged such that when a portion of the optical element is exposed to light, the optical element redirects at least a portion of the light into at least one microfluidic channel.

50 27. A fluidic device as in any one of the preceding items, wherein at least one microfluidic channel segment is part of a serpentine channel.

55 28. A fluidic device as in any one of the preceding items, wherein the article is a single, integral piece of material without joined layers.

29. A fluidic device as in any one of the preceding items, wherein the article is formed of a polymeric material.

30. A fluidic device as in any one of the preceding items, wherein the polymeric material is selected from polystyrene,

cyclo-olefin-copolymer, polymethylmethacrylate, and polycarbonate.

31. A fluidic device as in any one of the preceding items, wherein the article is made by injection molding.

5 32. A fluidic device as in any one of the preceding items, wherein one or more optical elements redirect at least 10% of the incident light away from the intervening portion.

10 33. A fluidic device as in any one of the preceding items, wherein one or more optical elements redirect at least 25% of the incident light away from the intervening portion.

34. A fluidic device as in any one of the preceding items, wherein one or more optical elements redirect at least 50% of the incident light away from the intervening portion.

15 35. A fluidic device as in any one of the preceding items, wherein one or more optical elements redirect at least 75% of the incident light away from the intervening portion.

36. A fluidic device as in any one of the preceding items, wherein one or more optical elements span at least 50% of the length of the first microfluidic channel segment.

20 37. A fluidic device as in any one of the preceding items, wherein the at least one optical element has a longest width greater than or equal to the width of an intervening portion positioned substantially between the first microfluidic channel segment and a second microfluidic channel segment, but less than the combination of the widths of the two microfluidic channel segments and the width of the intervening portion.

25 38. A fluidic device as in any one of the preceding items, further comprising a cover positioned over one or more microfluidic channel segments to substantially enclose the one or more microfluidic channel segments.

39. A fluidic device as in any one of the preceding items, wherein the cover comprises a tape.

30 40. A fluidic device as in any one of the preceding items, further comprising a reaction site in fluid communication with the first microfluidic channel segment.

35 41. A fluidic device as in any one of the preceding items, wherein the reaction site comprises a binding partner associated with a surface of the first microfluidic channel segment.

42. A fluidic device as in any one of the preceding items, wherein the binding partner comprises an antibody or an antigen.

40 43. A fluidic device as in any one of the preceding items, further comprising a detector associated with one or more microfluidic channel segments.

44. A fluidic device as in any one of the preceding items, wherein the detector is adapted and arranged to determine light transmission through one or more microfluidic channel segments.

45 45. A fluidic device as in any one of the preceding items, wherein the first optical element is adapted and arranged such that when a portion of the article is exposed to light at a first intensity, the first optical element redirects at least a portion of the light away from the intervening portion, such that the intervening portion is exposed to the light at a second intensity lower than an intensity of the light at the intervening portion absent the first optical element.

50 46. A fluidic device as in any one of the preceding items, wherein the first optical element is adapted and arranged such that when a portion of the article is exposed to light at a first intensity, the first optical element redirects at least a portion of the light away from the intervening portion, such that the intervening portion is exposed to the light at a second intensity at least 50% lower than an intensity of the light at the intervening portion absent the first optical element.

55 47. A fluidic device as in any one of the preceding items, wherein the first optical element is adapted and arranged such that when a portion of the article is exposed to light at a first intensity, the first optical element redirects at least a portion of the light away from the intervening portion, such that the intervening portion is exposed to the light at a

second intensity at least 75% lower than an intensity of the light at the intervening portion absent the first optical element.

5 48. A fluidic device as in any one of the preceding items, wherein the second intensity is at least 25% lower than the first intensity.

49. A fluidic device as in any one of the preceding items, wherein the second intensity is at least 50% lower than the first intensity.

10 50. A fluidic device as in any one of the preceding items, wherein the second intensity is at least 75% lower than the first intensity.

15 51. A fluidic device as in any one of the preceding items, wherein the intervening portion is a portion of the first surface of the article.

20 52. A fluidic device as in any one of the preceding items, wherein at least one optical element is adapted and arranged such that when a portion of the article is exposed to light, the at least one optical element redirects at least a portion of the light away from a surface portion of the first side, the surface portion being adjacent to at least one microfluidic channel segment.

25 53. A fluidic device as in any one of the preceding items, wherein the first optical element is adapted and arranged such that when a portion of the article is exposed to light at a first intensity, the optical element redirects at least a portion of the light incident upon the optical element in a direction away from a central plane of the optical element such that the portion of the device directly below the optical element is not exposed to the light or is exposed to the light at a second intensity at least 25% lower than the first intensity.

30 54. A fluidic device as in any one of the preceding items, wherein the first and/or second microfluidic channel segments are sections of a microfluidic channel comprising a meandering configuration including multiple turns, each turn of the meandering channel being a different channel segment.

55. A fluidic device as in any one of the preceding items, wherein the intervening portion is a non-channel portion.

35 56. A fluidic device as in any one of the preceding items, wherein the first and/or second microfluidic channel segments has a length of at least 1 cm.

## Claims

- 40 1. A multiplex assay system comprising:
- an article supporting solid-phase assays,  
said article comprising a rigid planar substrate and comprising two or more different liquid containment regions,  
each liquid containment region comprising at least one analysis region that can be interrogated optically, each  
45 analysis region having one or more binding partners associated with a surface of the substrate, wherein said  
binding partners bind one or more analytes present in a sample in the liquid containment region.
- 50 2. The multiplex assay system of claim 1, wherein for at least one liquid containment region, the one or more analytes is selected from the group consisting of prostate specific antigen (PSA), free PSA, complexed-PSA, pro-PSA and human kallikrein protein (hk2).
- 55 3. The multiplex assay system of claim 1, wherein the protein binding partner is an antibody.
4. The multiplex assay system of claim 1, the fluid sample obtained from a whole blood, blood serum, or blood plasma sample.
5. The multiplex assay system of claim 1, further comprising an optical device configured to detect light from the analysis region or supply collimated light to illuminate an analysis region of the two or more liquid containment regions and detect light

from the illuminated analysis region.

- 5
6. The multiplex assay system of claim 5, wherein the optical device comprises a light source and a detector or a light source and a photodiode detector or an image sensor that detects light from one or more analysis regions or a camera or imaging system.
- 10
7. The multiplex assay system of claim 6, wherein the rigid planar substrate is positioned between the light source and the optical detector such that a first side of the substrate faces the detector and a second side of the substrate faces the light source and is exposed to light.
- 15
8. The multiplex assay system of claim 7, further comprising a positioning system configured to position the detector over an analysis region.
- 20
9. The multiplex assay system of claim 6, wherein the detector is configured to detect photoluminescence, fluorescence, chemiluminescence, bioluminescence, and/or electrochemiluminescence.
- 25
10. The multiplex assay system of claim 1, wherein each different liquid containment region is a chamber having a depth measured perpendicular to a surface of the rigid planar substrate and a cross-sectional dimension substantially parallel to the surface of the rigid planar substrate.
- 30
11. The multiplex assay system of claim 10, wherein the chamber is integral to a surface of the rigid planar substrate or comprises a separate structure connected to the rigid planar substrate or is covered or uncovered.
- 35
12. The multiplex assay system of claim 11, wherein the separate structure is connected to the rigid planar substrate through an adhesive, preferably an acrylic or silicone based adhesive, and/or van der Waals forces.
- 40
13. The multiplex assay system of claim 1, wherein the rigid planar substrate is a polyethylene, polystyrene, polymethylmethacrylate, polycarbonate, poly(dimethylsiloxane), polytetrafluoroethylene, polyethylene terephthalate, or cyclo-olefin copolymer substrate or a glass, quartz, or silicon substrate, or wherein the rigid planar substrate is a single, integral piece of material without joined layers.
- 45
14. The multiplex assay system of claim 1, wherein each different liquid containment region is configured to contain less than 1 milliliter of liquid.
- 50
15. The multiplex assay system of claim 1, further comprising a second article comprising a rigid planar substrate comprising at least one analysis region in which one or more nucleic acid binding partners are associated with a surface of the substrate of the second article.
- 55

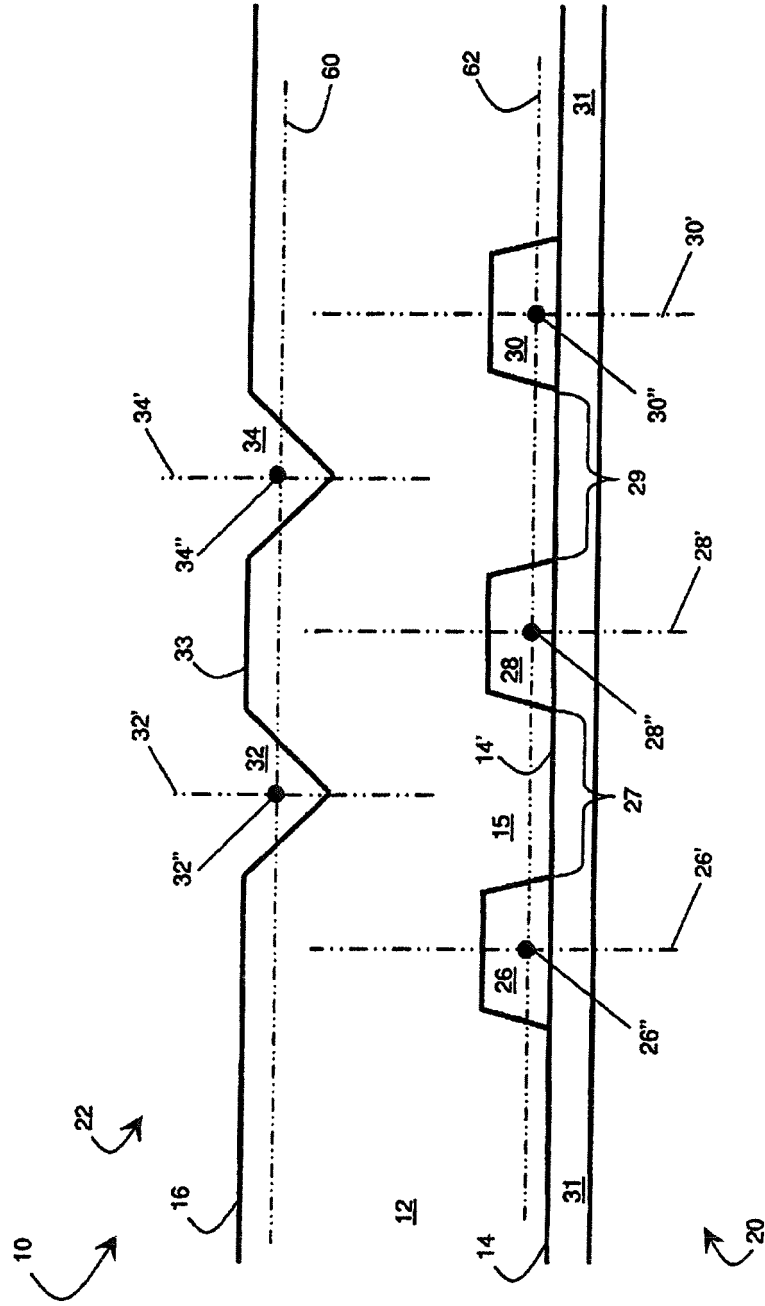

FIG. 1A

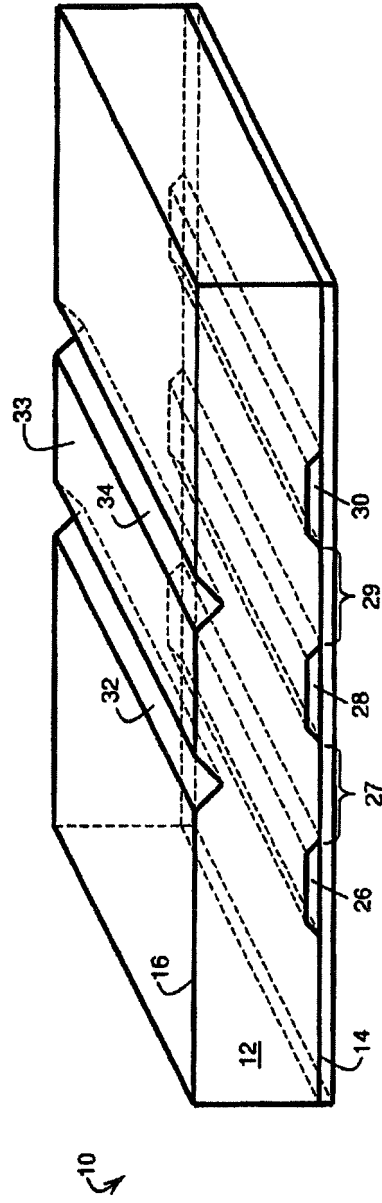

FIG. 1B

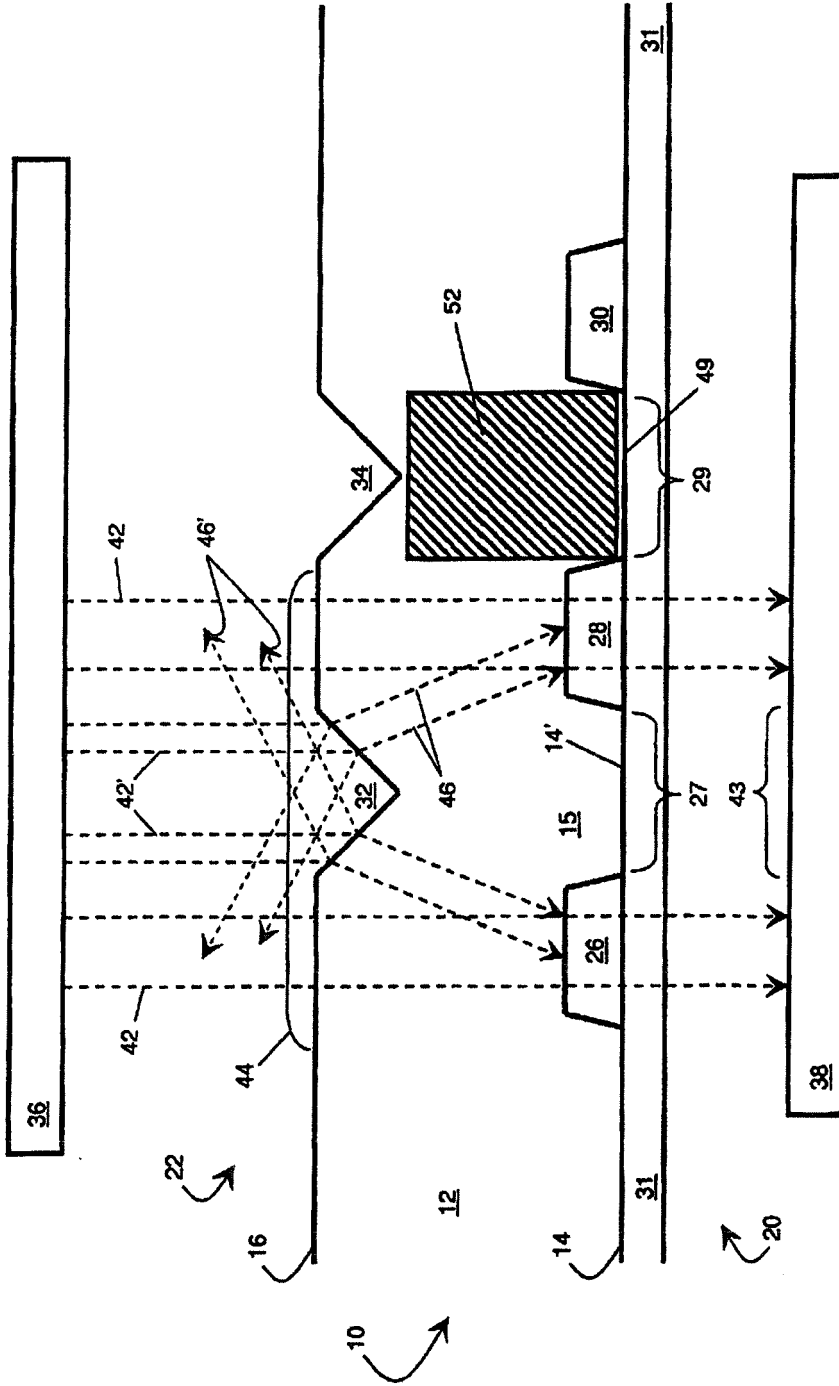

FIG. 1C

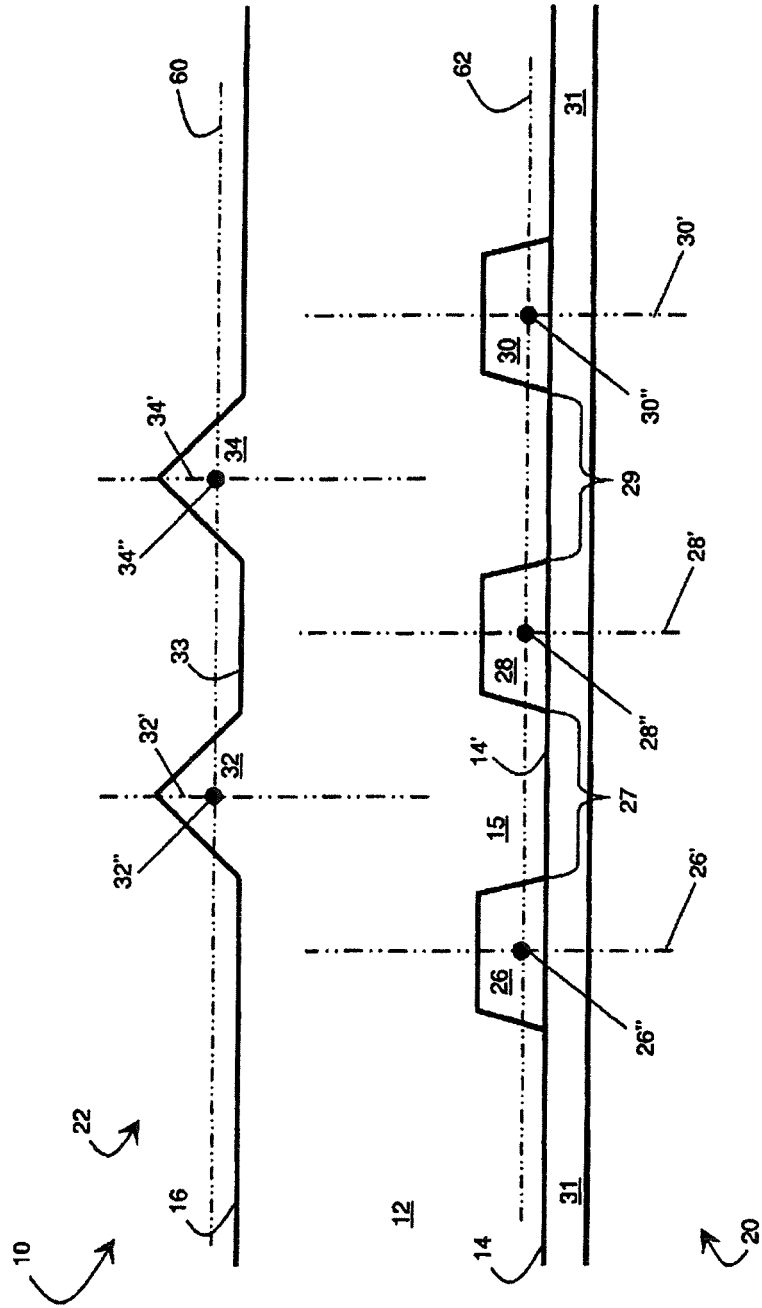

FIG. 1D

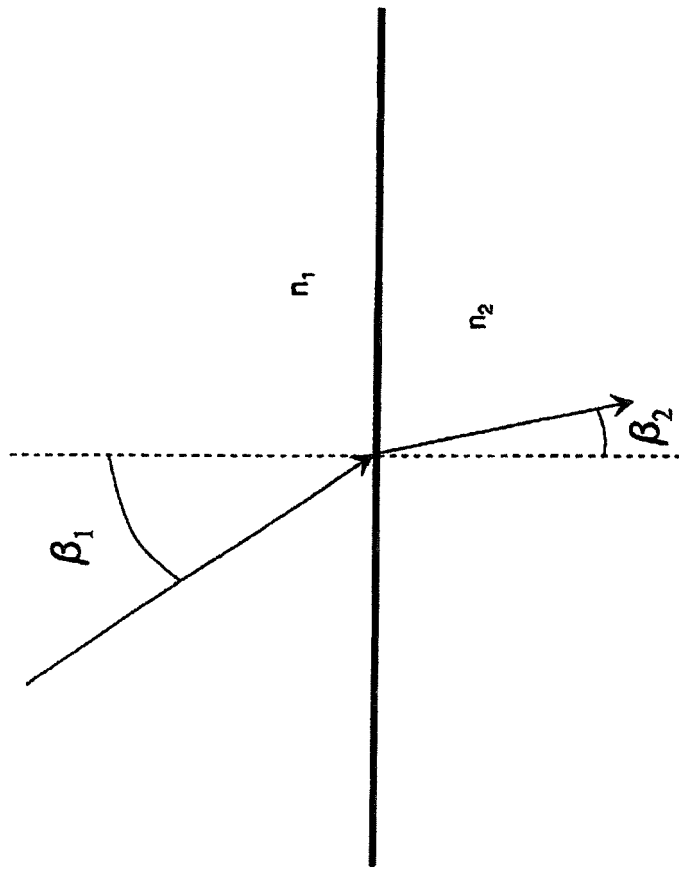

FIG. 1E

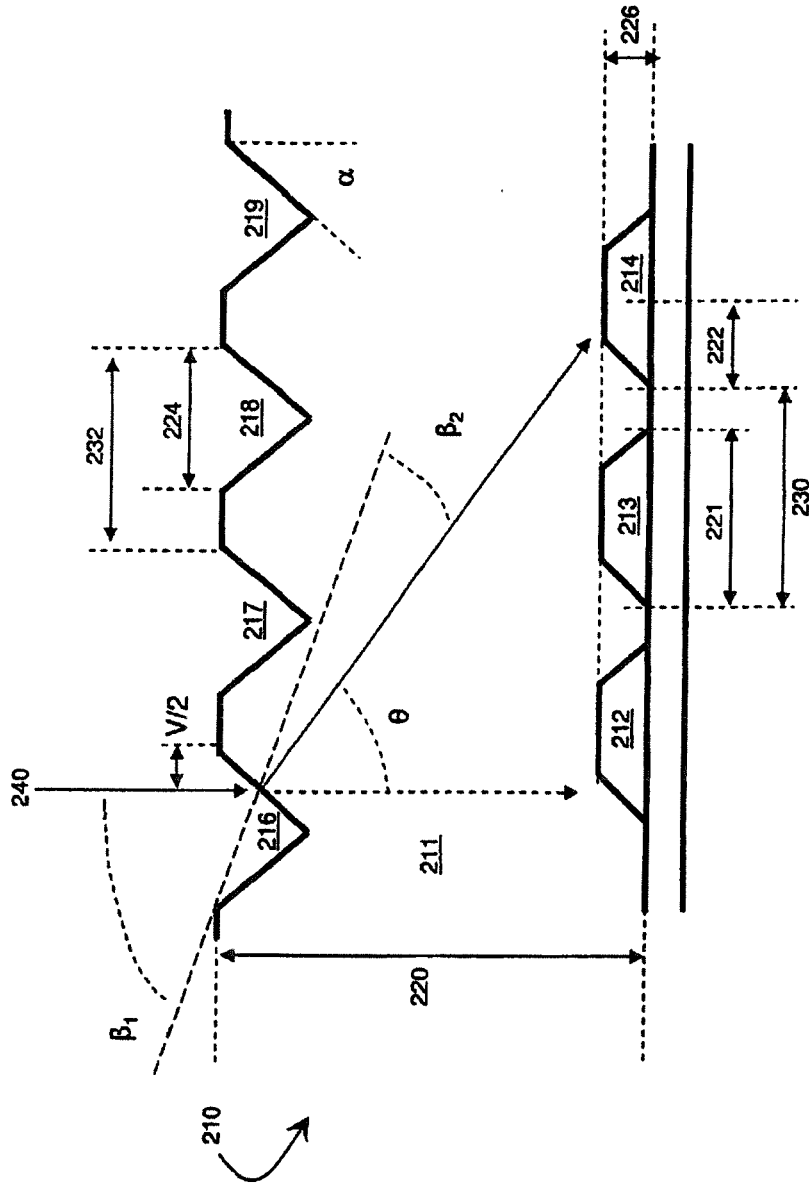

FIG. 2A

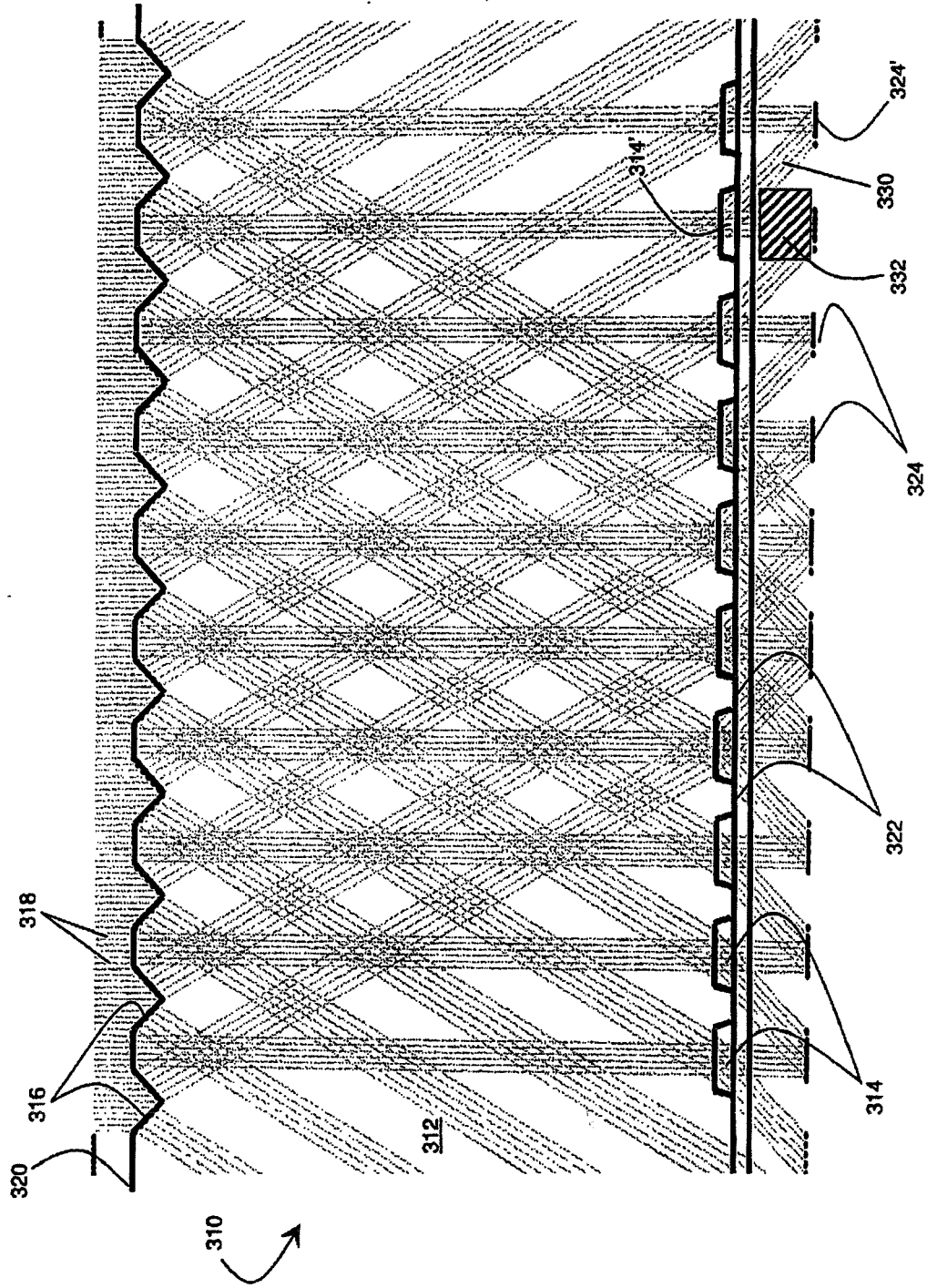

FIG. 2B

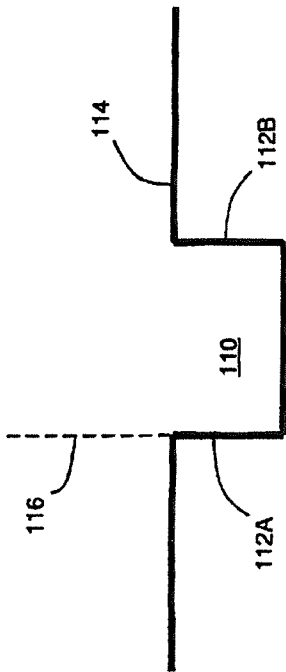

FIG. 3A

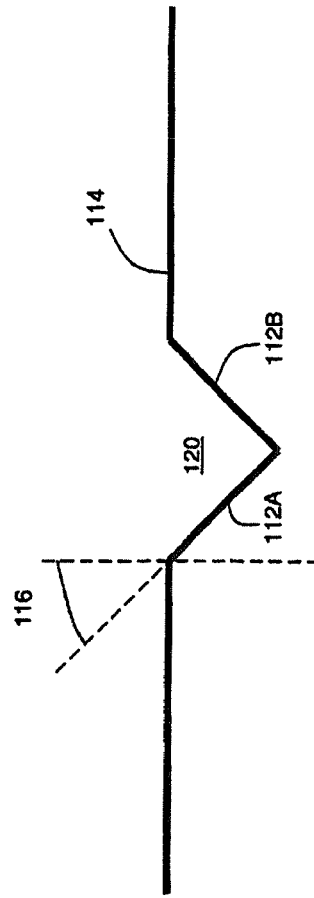

FIG. 3B

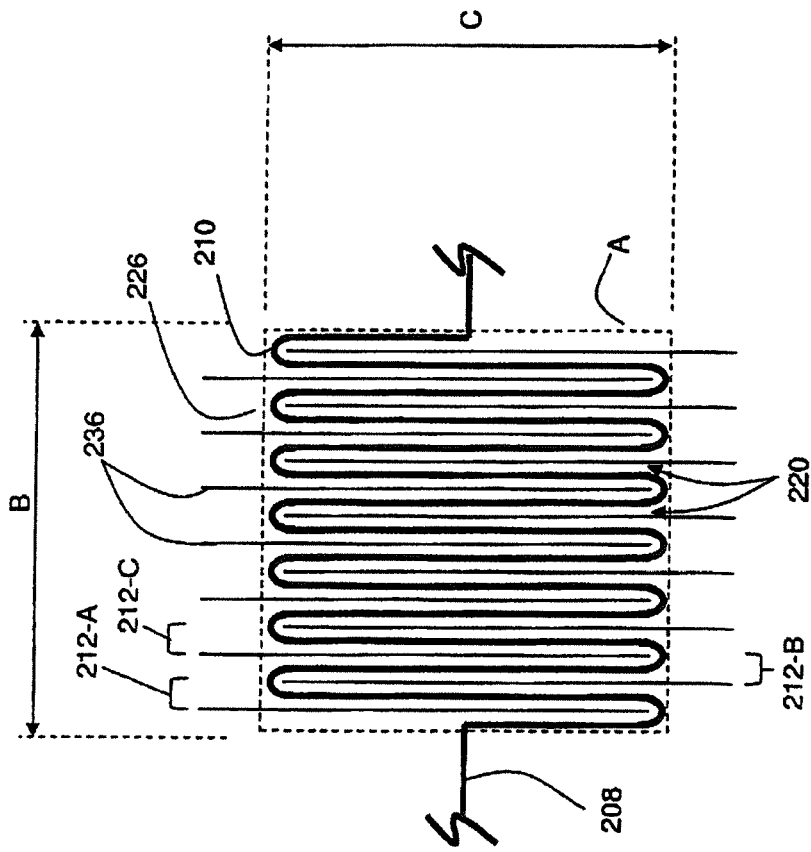

FIG. 3C

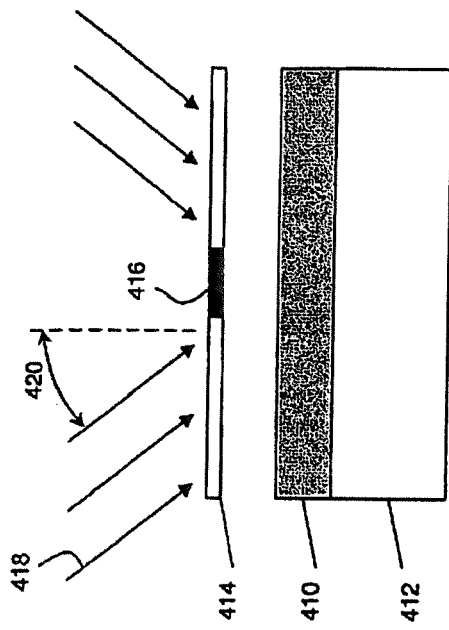

FIG. 4A

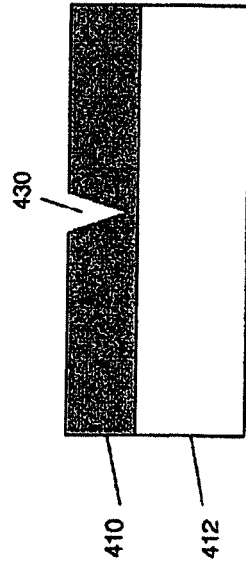

FIG. 4B

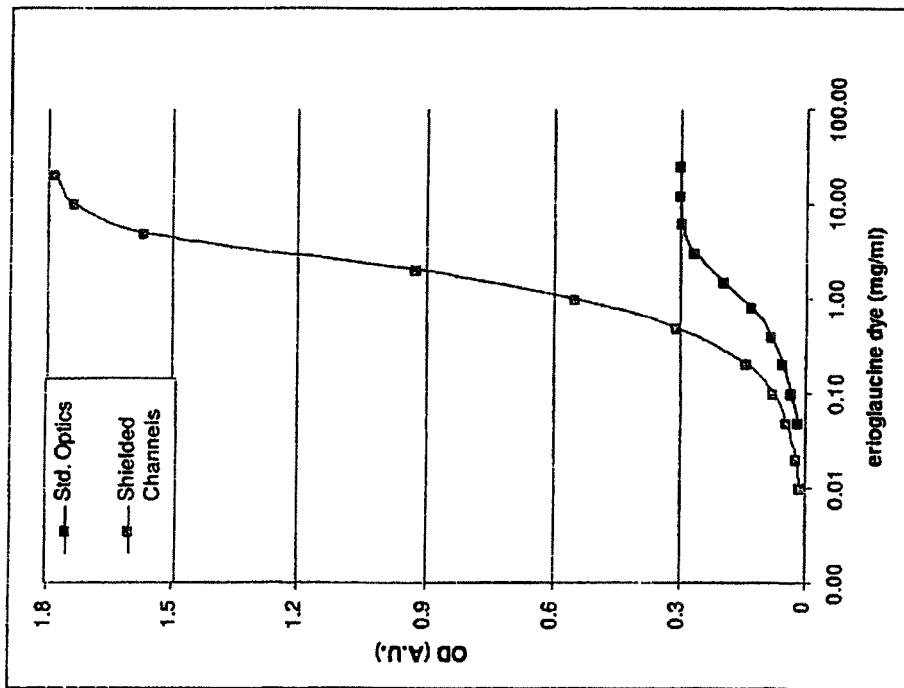

FIG. 5

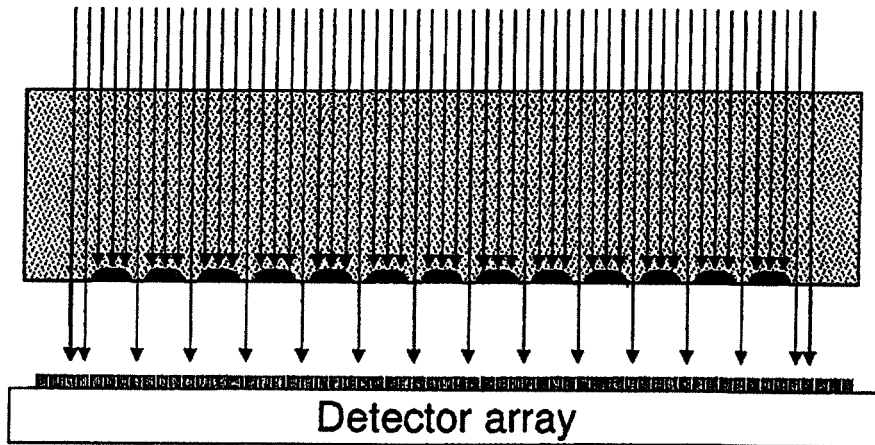

FIG. 6A

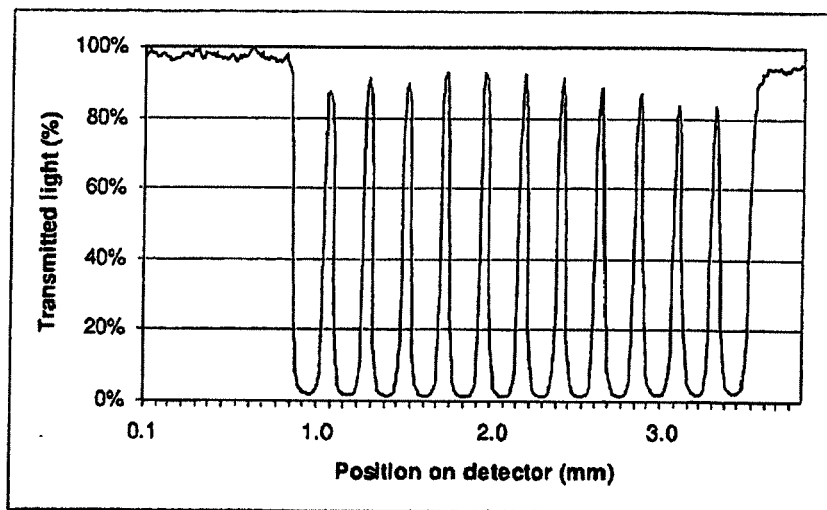

FIG. 6B

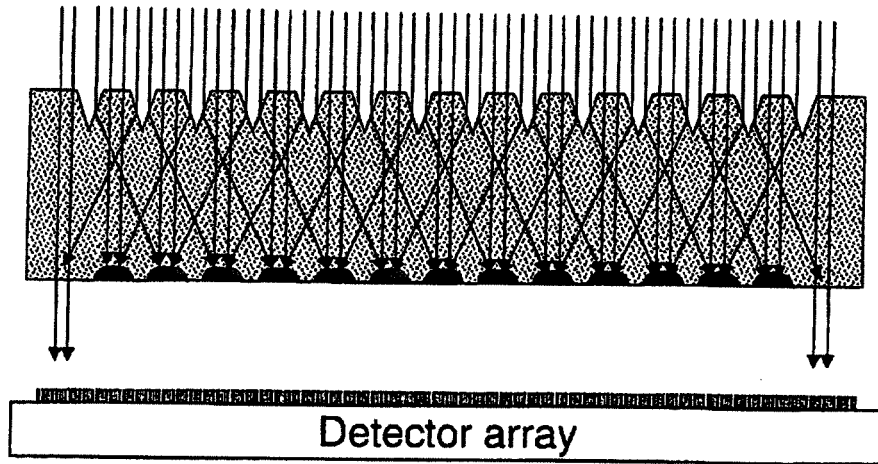

FIG. 6C

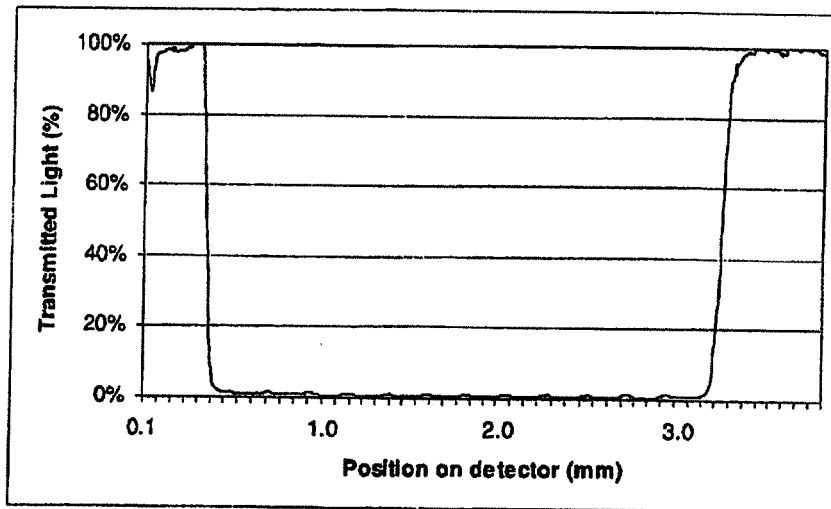

FIG. 6D

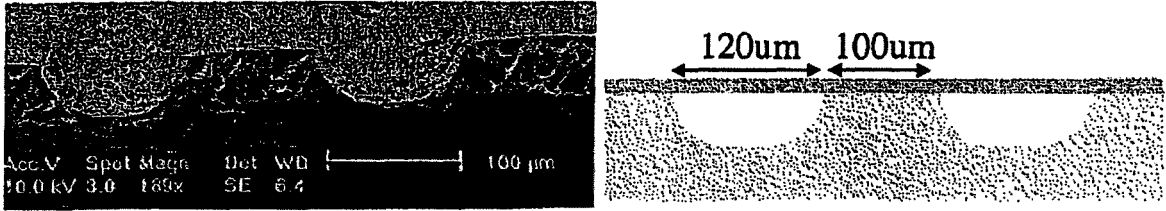

FIG. 7A

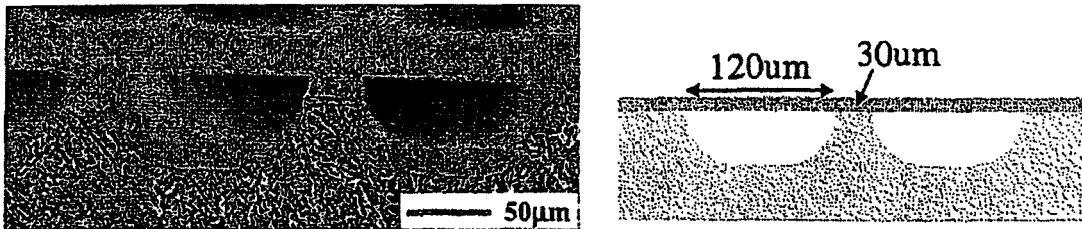

FIG. 7B

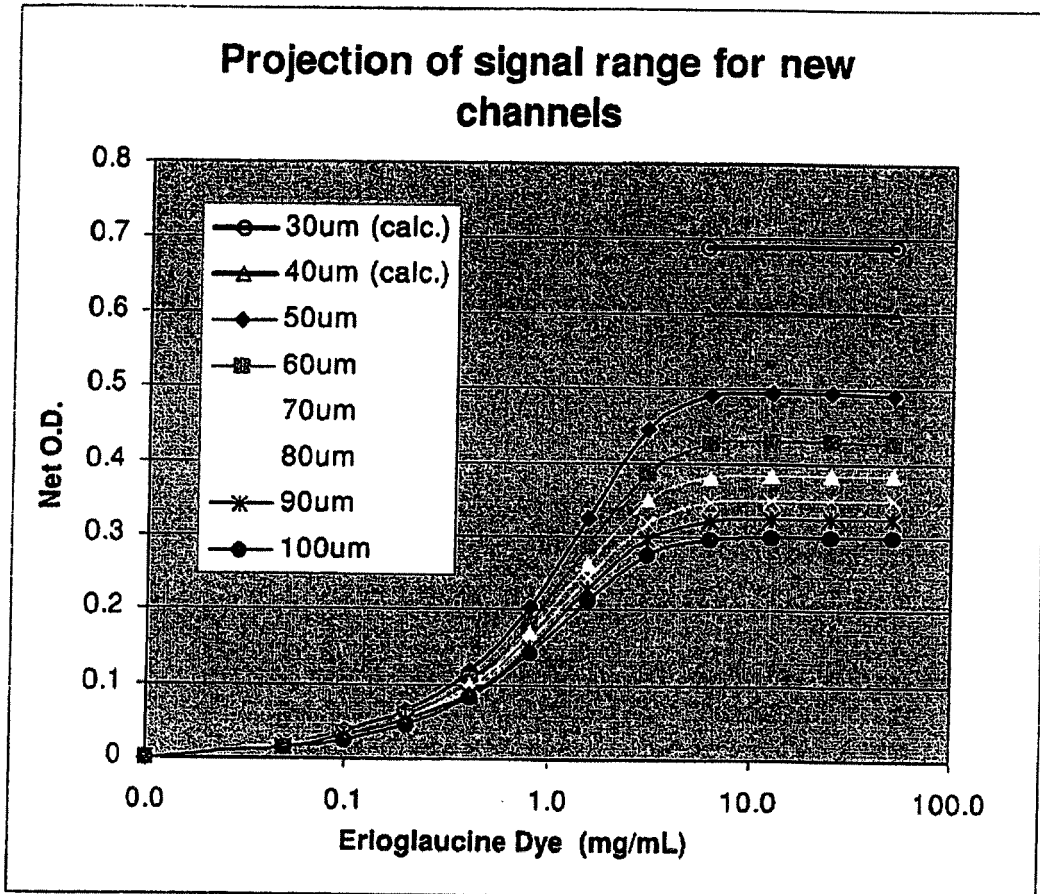

FIG. 7C

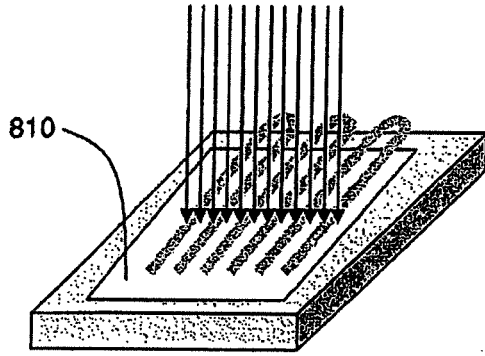

FIG. 8A

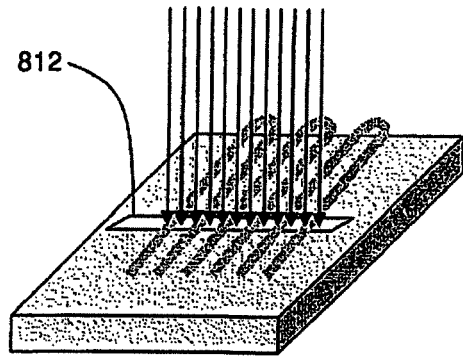

FIG. 8B

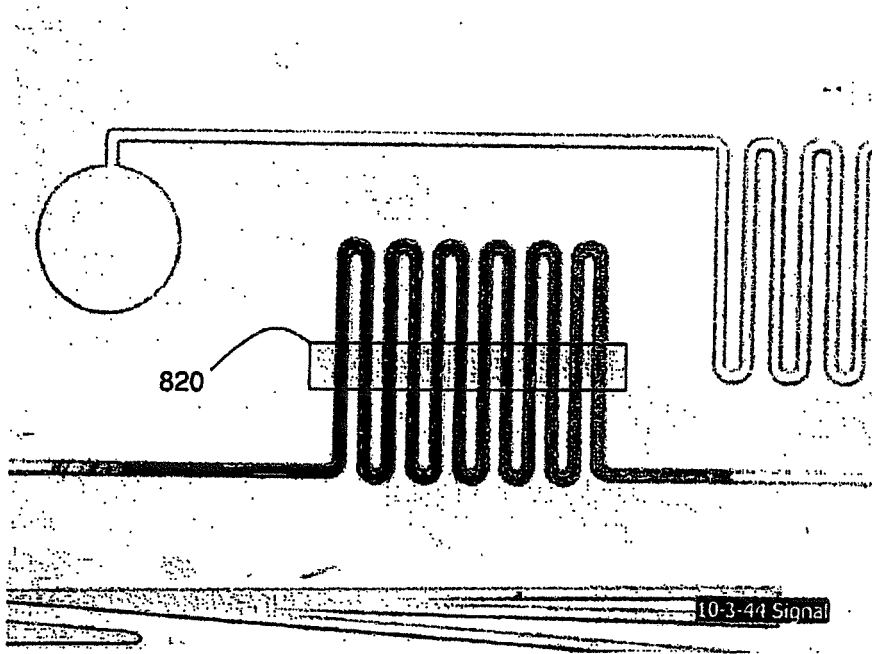

FIG. 8C

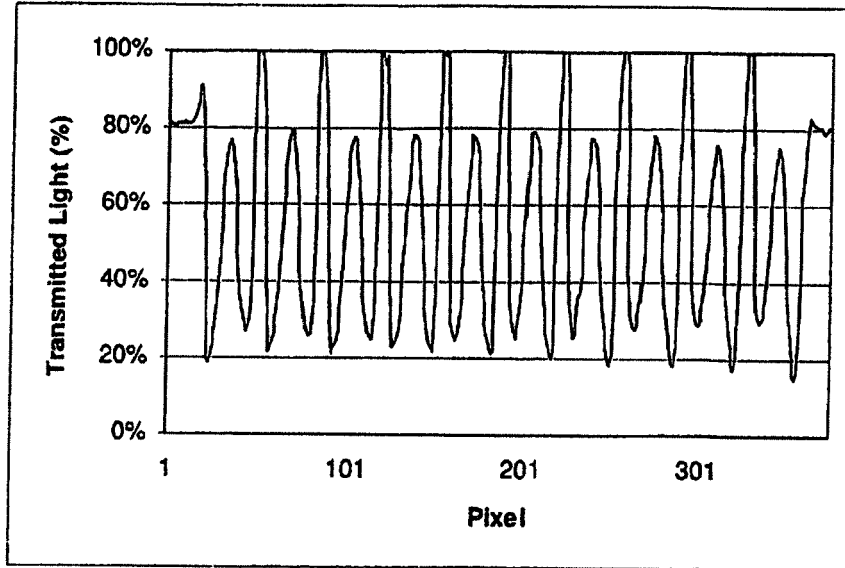

FIG. 9A

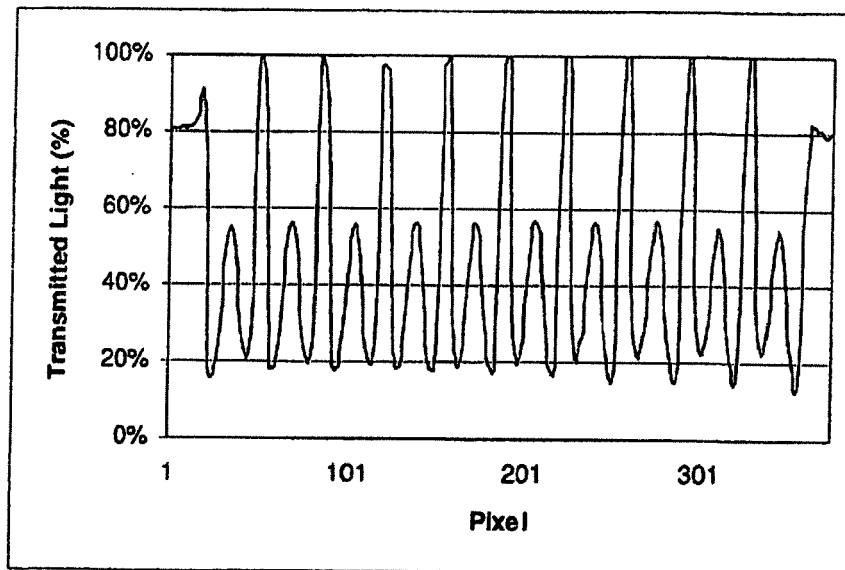

FIG. 9B

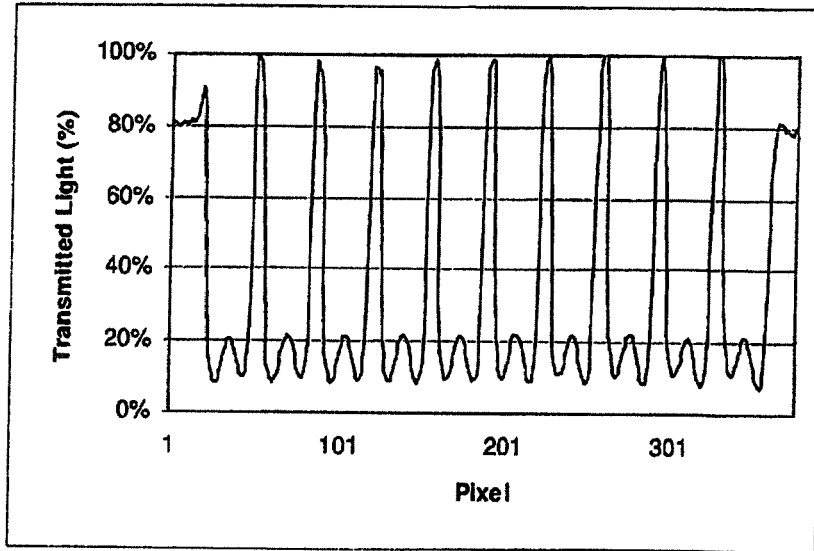

FIG. 9C

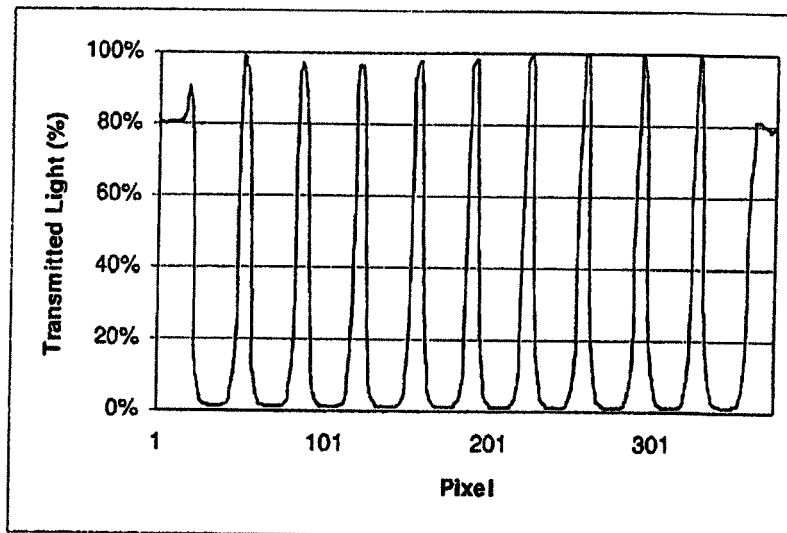

FIG. 9D

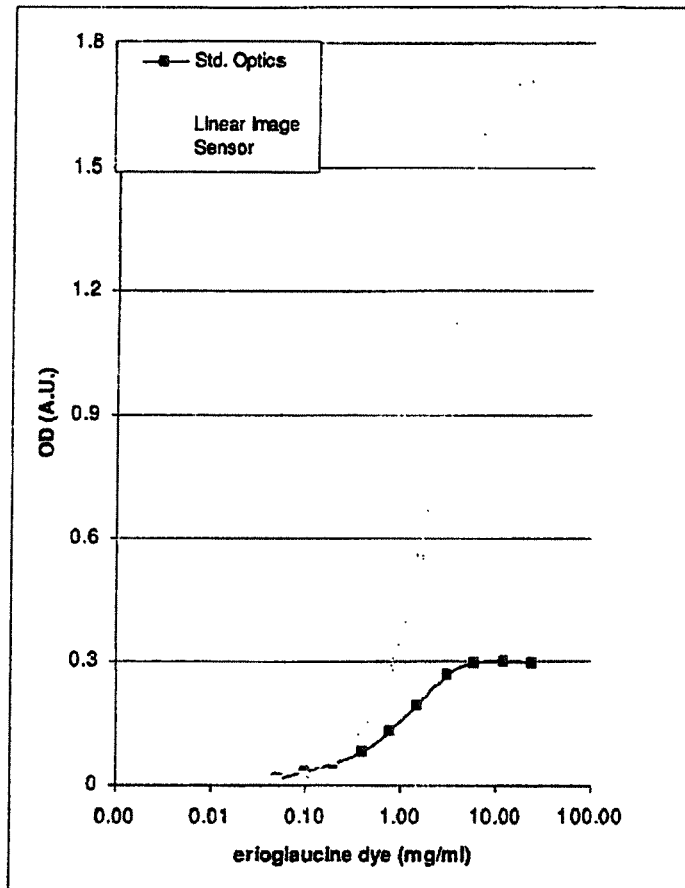

FIG. 10



EUROPEAN SEARCH REPORT

Application Number  
EP 17 17 8988

5

10

15

20

25

30

35

40

45

50

55

DOCUMENTS CONSIDERED TO BE RELEVANT			
Category	Citation of document with indication, where appropriate, of relevant passages	Relevant to claim	CLASSIFICATION OF THE APPLICATION (IPC)
X,D	WO 2005/072858 A1 (HARVARD COLLEGE [US]; SIA SAMUEL K [US]; LINDER VINCENT [CH]; WHITESID) 11 August 2005 (2005-08-11) * the whole document * & EP 1 776 181 A1 (HARVARD COLLEGE [US]) 11 September 2013 (2013-09-11) * paragraphs [0039], [0072] - [0087]; figures 1-3, 9, 18 *	1-15	INV. B01L3/00 G01N21/03 G01N21/59 G01N33/53 G01N33/543 G01N33/545 G01N33/574
X	US 2002/071788 A1 (FUJII YASUHISA [JP] ET AL) 13 June 2002 (2002-06-13) * paragraphs [0054] - [0069]; figures 1-10 *	1-15	ADD. G01N21/05
X	JP H03 223674 A (MOCHIDA PHARM CO LTD) 2 October 1991 (1991-10-02) * the whole document *	1-15	
X	EP 0 488 947 A1 (CIBA GEIGY AG [CH]) 3 June 1992 (1992-06-03) * page 4, line 22 - page 5, line 3; figure 4 *	1-15	
			TECHNICAL FIELDS SEARCHED (IPC)
			B01L G01N
The present search report has been drawn up for all claims			
Place of search The Hague		Date of completion of the search 21 November 2017	Examiner Viskanic, Martino
CATEGORY OF CITED DOCUMENTS X : particularly relevant if taken alone Y : particularly relevant if combined with another document of the same category A : technological background O : non-written disclosure P : intermediate document		T : theory or principle underlying the invention E : earlier patent document, but published on, or after the filing date D : document cited in the application L : document cited for other reasons ..... & : member of the same patent family, corresponding document	

EPO FORM 1503 03/02 (P04/C01)

ANNEX TO THE EUROPEAN SEARCH REPORT  
ON EUROPEAN PATENT APPLICATION NO.

EP 17 17 8988

5

This annex lists the patent family members relating to the patent documents cited in the above-mentioned European search report. The members are as contained in the European Patent Office EDP file on  
The European Patent Office is in no way liable for these particulars which are merely given for the purpose of information.

21-11-2017

10

15

20

25

30

35

40

45

50

55

Patent document cited in search report	Publication date	Patent family member(s)	Publication date
WO 2005072858 A1	11-08-2005	AU 2005209321 A1	11-08-2005
		CA 2564211 A1	11-08-2005
		CN 1953802 A	25-04-2007
		CN 102357352 A	22-02-2012
		DK 1776181 T3	06-01-2014
		EP 1776181 A1	25-04-2007
		EP 2523004 A1	14-11-2012
		ES 2439225 T3	22-01-2014
		JP 4698613 B2	08-06-2011
		JP 5580186 B2	27-08-2014
		JP 2007524851 A	30-08-2007
		JP 2011090009 A	06-05-2011
		PT 1776181 E	02-01-2014
		US 2011315229 A1	29-12-2011
		US 2014038167 A1	06-02-2014
		US 2015233901 A1	20-08-2015
WO 2005072858 A1	11-08-2005		
US 2002071788 A1	13-06-2002	JP 2002236131 A	23-08-2002
		US 2002071788 A1	13-06-2002
JP H03223674 A	02-10-1991	NONE	
EP 0488947 A1	03-06-1992	DE 59104604 D1	23-03-1995
		EP 0488947 A1	03-06-1992
		JP H04268437 A	24-09-1992
		US 5599503 A	04-02-1997

EPO FORM P0459

For more details about this annex : see Official Journal of the European Patent Office, No. 12/82

**REFERENCES CITED IN THE DESCRIPTION**

*This list of references cited by the applicant is for the reader's convenience only. It does not form part of the European patent document. Even though great care has been taken in compiling the references, errors or omissions cannot be excluded and the EPO disclaims all liability in this regard.*

**Patent documents cited in the description**

- US 61149253 A [0001] [0021]
- WO 200611372 A [0015]
- US 2006014583 W [0015]
- WO 2005066613 A [0021]
- US 2004043585 W [0021]
- WO 2005072858 A [0021] [0089]
- US 2005003514 W [0021] [0089]
- WO 2006113727 A [0021] [0066]
- US 0614583 W [0021]
- US 11350308 A [0021] [0081]
- US 12196392 B [0021] [0076]
- US 12428372 B [0021]
- US 61263981 B [0021]
- US 12640420 B [0021] [0089]
- US 4444616 A [0107]

专利名称(译)	用于控制与微流体装置的光相互作用的结构		
公开(公告)号	<a href="#">EP3278877A1</a>	公开(公告)日	2018-02-07
申请号	EP2017178988	申请日	2010-02-02
[标]申请(专利权)人(译)	欧普科诊断有限责任公司		
申请(专利权)人(译)	OPKO诊断, LLC		
当前申请(专利权)人(译)	OPKO诊断, LLC		
[标]发明人	STEINMILLER DAVID LINDER VINCENT		
发明人	STEINMILLER, DAVID LINDER, VINCENT		
IPC分类号	B01L3/00 G01N21/03 G01N21/59 G01N33/53 G01N33/543 G01N33/545 G01N33/574 G01N21/05		
CPC分类号	B01L3/502707 B01L2300/0654 C12Y304/21077 G01N21/0303 Y10T436/11 B01L3/5027 B01L3/502715 B01L2200/12 B01L2300/04 B01L2300/0627 B01L2300/0861 B01L2300/12 G01N21/59 G01N33/53 G01N33/54366 G01N33/54373 G01N33/545 G01N33/57488 G01N2333/96455		
优先权	61/149253 2009-02-02 US PCT/US2010/000286 2010-02-02 WO		
其他公开文献	EP3278877B1		
外部链接	<a href="#">Espacenet</a>		

摘要(译)

本关系涉及包含支持固相测定的制品的多重测定系统，所述制品包括刚性平面基底并且包括两个或更多个不同的液体容纳区域，每个液体容纳区域包括至少一个可以光学查询的分析区域每个分析区域具有一个或多个与底物表面相关的结合配偶体，其中所述结合配偶体结合液体容纳区域中样品中存在的一种或多种分析物。

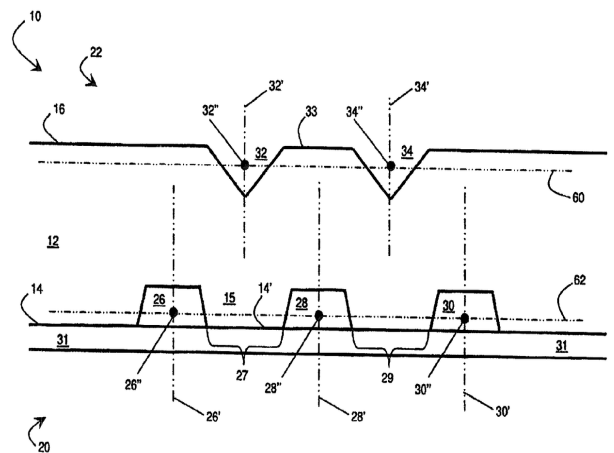

FIG. 1A