



(11) **EP 2 534 490 B1**

(12) **EUROPEAN PATENT SPECIFICATION**

(45) Date of publication and mention of the grant of the patent:
16.12.2015 Bulletin 2015/51

(51) Int Cl.:
G01N 33/68 (2006.01) G01N 33/531 (2006.01)
C07K 19/00 (2006.01)

(21) Application number: **11704514.6**

(86) International application number:
PCT/US2011/024151

(22) Date of filing: **09.02.2011**

(87) International publication number:
WO 2011/100292 (18.08.2011 Gazette 2011/33)

(54) **IMMUNOASSAY STANDARDS AND MEASUREMENT OF CLINICAL BIOMARKERS USING INTRA-ASSAY CALIBRATION STANDARDS**

IMMUNOASSAYSTANDARDS UND MESSUNG VON KLINISCHEN BIOMARKERN ANHAND VON INTRA-ASSAY-KALIBRIERSTANDARDS

NORMES D'IMMUNOESSAI ET MESURE DE BIOMARQUEURS CLINIQUES UTILISANT DES NORMES D'ÉTALONNAGE INTRA-ESSAI

(84) Designated Contracting States:
AL AT BE BG CH CY CZ DE DK EE ES FI FR GB GR HR HU IE IS IT LI LT LU LV MC MK MT NL NO PL PT RO RS SE SI SK SM TR

(74) Representative: **Reitstötter Kinzebach**
Patentanwälte
Sternwartstrasse 4
81679 München (DE)

(30) Priority: **09.02.2010 US 302835 P**

(56) References cited:
WO-A2-2007/090126 US-A1- 2002 182 660

(43) Date of publication of application:
19.12.2012 Bulletin 2012/51

(73) Proprietor: **Bristol-Myers Squibb Company**
Princeton, NJ 08543 (US)

- **WURTH C ET AL: "Mutations that Reduce Aggregation of the Alzheimer's Abeta42 Peptide: an Unbiased Search for the Sequence Determinants of Abeta Amyloidogenesis", JOURNAL OF MOLECULAR BIOLOGY, LONDON, GB, vol. 319, no. 5, 21 June 2002 (2002-06-21), pages 1279-1290, XP004449702, ISSN: 0022-2836, DOI: DOI:10.1016/S0022-2836(02)00399-6**
- **LIAO ET AL: "The correlation between neurotoxicity, aggregative ability and secondary structure studied by sequence truncated Abeta peptides", FEBS LETTERS, ELSEVIER, AMSTERDAM, NL, vol. 581, no. 6, 13 March 2007 (2007-03-13), pages 1161-1165, XP005932069, ISSN: 0014-5793, DOI: 10.1016/J.FEBSLET. 2007.02.026**

(72) Inventors:

- **RHYNE, Paul**
Doylestown, PA 18902 (US)
- **MAPELLI, Claudio**
Lawrenceville, NJ 08543 (US)
- **WONG, Oitak**
Princeton, NJ 08540 (US)
- **BERISHA, Flora**
Lawrenceville, NJ 08543 (US)
- **NEELY, Robert John**
Lawrenceville, NJ 08543 (US)

Note: Within nine months of the publication of the mention of the grant of the European patent in the European Patent Bulletin, any person may give notice to the European Patent Office of opposition to that patent, in accordance with the Implementing Regulations. Notice of opposition shall not be deemed to have been filed until the opposition fee has been paid. (Art. 99(1) European Patent Convention).

EP 2 534 490 B1

Description

FIELD OF THE INVENTION

5 **[0001]** This invention relates to novel modified A β ₄₂ peptides that can be used as reference standards and calibrators in order to measure clinical biomarkers in an immunoassay. This invention also relates to methods of using the peptides and kits comprising the peptides.

BACKGROUND OF THE INVENTION

10 **[0002]** Amyloid Beta (A β) peptides are generated from the cleavage of Amyloid Precursor Protein (APP) via beta secretase and gamma secretase enzymatic complexes (Wolfe, *Biochemistry*, 45:7931-7939 (2006)). Beta secretase generates the N-terminal ends of these amyloid peptides and gamma secretase generates the C-terminal ends (Wolfe, *Biochemistry*, 45:7931-7939 (2006)). Several species of peptides are subsequently generated, typically ranging from
 15 38 to 42 amino acids in length depending on where the gamma secretase cleaves the APP. A β peptides have an extracellular domain (amino acids 1-28) and a transmembrane region (amino acids 29-42) that is embedded in the lipid bilayer. Amyloid peptides that are 42 amino acids long (A β ₄₂) are believed to be the putative neurotoxic species, either alone or as aggregates. These aggregates are suspected to contribute to the neurodegeneration of the brain resulting in Alzheimer's disease and dementia. The hypothesis that A β ₄₂ contributes to clinical dementias is called the amyloid
 20 cascade hypothesis as described by Hardy et al. (*Science*, 256:184-185 (1992)).

[0003] One of the characteristics of the A β peptides is the ability to self-assemble into oligomers at physiological concentrations (Burdick et al., *Journal of Biological Chemistry*, 267:546-554 (1992); Cerf et al., *Biochemical Journal*, 421:415-423 (2009)). The A β ₄₂ species is more prone to forming oligomers as compared to the A β ₄₀ and A β ₃₈ species. The mechanism of oligomer formation has been shown to originate from a small, five amino acid region located at amino
 25 acids 16 to 20 (KLVFF) which mediates the binding of A β peptides in an anti-parallel manner. This small region has thus been termed the "aggregation domain" (Tjernberg et al., *Journal of Biological Chemistry*, 271:8545-8548 (1996)). A β peptide aggregates assemble rapidly (*i.e.*, within minutes) under certain conditions especially at lower pH ranges, with slightly slower kinetics at neutral or higher pH (Burdick et al., *Journal of Biological Chemistry*, 267:546-554 (1992)). The aggregates are poorly soluble in aqueous solutions, especially in the presence of salts. The C-terminal ends of the A β
 30 peptides fold back over the core of the dimer via salt bridges thereby increasing their hydrophobicity and promoting further polymerization of the peptides into filaments or fibrils. The additional two C-terminal residues in the A β ₄₂ species provides increased hydrophobicity in comparison to the other A β species (Kim et al., *Journal of Biological Chemistry*, 280:35069-35076 (2005)).

[0004] Clinical data suggests that the degree of dementia and cognitive decline has a higher correlation with A β ₄₂
 35 concentration than either the A β ₄₀ or A β ₃₈ species. This observation, in conjunction with the rapid aggregation properties of A β ₄₂, has led to the hypothesis that inhibition of A β ₄₂ aggregation may have clinical benefits. There have been numerous studies showing different mechanisms that can be used to inhibit the formation of A β ₄₂ aggregates. Tjernberg et al. (*Journal of Biological Chemistry* 271: 8545-8548 (1996)) showed that peptides comprising the aggregation domain
 40 bind well to A β peptides and inhibit the formation of aggregates. Several other molecules that bind to the aggregation domain have also been shown to inhibit amyloid peptide aggregation (Martharu et al., *Journal of Neurological Sciences*, 280:49-58 (2009); Kim et al., *Biochemical and Biophysical Research Communications*, 303:576-279 (2003)). Substitution of amino acids in the aggregation core domain or the deletion of the entire aggregation domain also prevents A β peptide aggregation and fibril formation (Tjernberg et al., *Journal of Biological Chemistry*, 274:12619-12625 (1999)). In addition, various drugs have been designed to inhibit gamma secretase activity in order to lower the amount of A β ₄₂ and related
 45 peptide species. The usefulness of these approaches in the clinic is currently under investigation.

[0005] In order to assess the effectiveness of a molecule to inhibit the generation of A β ₄₂ or to prevent its aggregation, it is necessary to measure the amount of A β ₄₂ accurately. There are several techniques that are used to detect and
 50 quantitate A β ₄₂ in biological samples including both immunoassays (Olsson et al., *Clinical Chemistry*, 51:336-345 (2005); Verwey et al., *Journal of Immunological Methods*, 348:57-66 (2009); Sjogren et al., *Journal of Neural Transmission*, 107:563-679 (2000)) and mass spectrometry (MS) based methods (Cantone et al., *Journal of Neuroscience Methods*, 180:255-260 (2009); *Journal of Mass Spectrometry*, 40:142-145 (2005)). The MS based methods, including those of MALDI-TOF and SELDI-TOF along with liquid chromatography prepared mass spectrometry, are able to detect many of the amyloid beta species in a biological sample, but do not presently provide sufficient quantitative values that are
 55 needed for measuring A β ₄₂ in clinical samples.

[0006] Immunoassay methods are based on a double sandwich immunoassay that comprises one antibody that is specific to the N-terminus and a second antibody that is highly specific for the A β ₄₂ C-terminus (*i.e.*, does not recognize other A β peptide species). There are two basic versions of the immunoassays. The first version captures A β peptides in biological samples via a solid surface immobilized N-terminal region specific antibody. The A β ₄₂ specific antibody

carrying a tag is added to the immunoassay in order to complete the antibody sandwich. The second version captures A β peptides in biological samples via an A β_{42} C-terminal region specific antibody immobilized on a solid surface. The N-terminal region specific antibody carrying a tag is added to the immunoassay. In either version, the tag incorporated via the second antibody enables the detection of the complete complex. These assays are made quantitative by the use of A β_{42} reference standards, which are added in lieu of biological samples. The resulting signal measured from the reference standards are used to generate a standard curve which is subsequently used to quantify the amount of A β_{42} in the biological samples.

[0007] Until now, the use of A β_{42} reference standards in immunoassays has relied on synthetic, full length A β_{42} peptides which are typically generated with minimal difficulty. However, these peptides have strong hydrophobic properties and, therefore, are not soluble in aqueous solutions. In addition, the storage and use of A β_{42} as reference standards presents many issues. As discussed, A β_{42} forms aggregates rapidly and this formation occurs more readily at room temperatures and neutral pH. Long term storage at low temperatures (below -20 °C) and low pH helps to minimize aggregation during storage but it does not prevent it. Reconstitution of A β_{42} in buffers that are amenable to immunoassays can also prove difficult. These solutions are almost always aqueous, buffered at a neutral pH, contain salts, and used at room temperature; all the conditions that accelerate A β_{42} aggregation. A β_{42} peptides that have aggregated are not useful as reference standards in immunoassays because of the insoluble precipitates and nonuniformity in both size and availability to be recognized by either detection or capture antibodies.

[0008] Thus, the present invention fulfills a need in the art by providing modified A β_{42} peptides that can be used as reference standards or calibrators in an immunoassay or other format to measure the abundance of A β_{42} peptide accurately in a fluid or tissue extract sample. Specifically, the present invention provides non-aggregating peptide reference standards for A β_{42} for use in immunoassay formats. The peptides and methods described herein have a broad applicability to many other peptides that are difficult to measure and quantitate.

Synthetic aggregated peptides (SAPs) comprising a portion of an aggregated biomarker such as aggregated A β are described in WO 2007/090126. Mutations that reduce aggregation of the A β_{42} peptide are described by Wurth et al., J Mol Biol 319:1279-90, 2002. An assay for simultaneous quantification of full-length A β peptides in biological matrices is described in US 2002/0182660. Liao et al. (FEBS Letters 581:1161-65, 2007) reports on a study of the correlation between neurotoxicity, aggregative ability and secondary structure using sequence truncated A β peptides.

BRIEF SUMMARY OF THE INVENTION

[0009] In one aspect, the invention provides a modified A β_{42} peptide comprising the N-terminal immunoreactive domain and the C-terminal immunoreactive domain of A β_{42} , wherein the central aggregation domain amino acids 17-20 and various lengths of the adjacent C-terminal peptide are replaced with a linker selected from a linker having the amino acid sequence EERP or DREPNR, linkers consisting of an integer number of lysine residues or an integer number of glutamic acid residues or an integer number of alanine residues, polyethylene glycols (PEGs), and dendrimers and branched co-polymers able to couple amino acid residues. In another aspect, the invention provides the use of the modified A β_{42} peptide as a reference standard in an immunoassay. In one embodiment, the immunoassay is selected from the group consisting of a sandwich immunoassay, a single antibody assay, a double sandwich immunoassay and a competition assay.

[0010] In another aspect, the invention provides an isolated peptide molecule having an amino acid sequence of SEQ ID NO:5, 6, 7, 8, 9, 10, 11, 12, 13, or 14.

[0011] In another aspect, the invention provides a method of measuring the quantity of an A β peptide analyte selected from A β_{42} , A β_{40} , and A β_{38} in a biological sample, the method comprising: attaching a reference standard to at least two beads thereby forming a first bead set and a second bead set, wherein the reference standard comprises an epitope recognized by a first detection antibody and wherein each bead set comprises a different concentration of the reference standard; attaching a capture antibody specific to the analyte to a third bead set; mixing all of the bead sets together to form a suspension array; applying the biological sample to the suspension array whereby the analyte binds to the capture antibody on the third bead set; adding a first detection antibody to the suspension array, wherein the first detection antibody binds the reference standard and analyte bound to the capture antibody; measuring a first signal from the first detection antibody bound to the reference standard in the first bead set; measuring a second signal from the first detection antibody bound to the reference standard in the second bead set; generating a standard curve based upon the first and second signals; and quantitating the amount of the analyte in the third bead set by measuring a third signal from the first detection antibody and comparing the third signal to the first and second signal measurements on the standard curve.

[0012] In one embodiment, the reference standard comprises a modified A β_{42} peptide having an amino acid sequence of SEQ ID NO:5, 6, 7, 8, 9, 10, 11, 12, 13, or 14.

[0013] In another embodiment, the biological sample is selected from the group consisting of blood, serum, plasma, peripheral blood mononuclear cells, peripheral blood lymphocytes, tissue, cerebrospinal fluid and cells..

[0014] In another embodiment, the method is performed in a multi-well plate, nitrocellulose filter, glass fiber or on a

glass slide. In another embodiment, the first signal and second signal is a signal selected from the group consisting of phycoerythrin, alexa 532, streptavidin-phycoerythrin and streptavidin-Alexa 532. In another embodiment, the reference standard is covalently attached to the bead. In another embodiment, the capture antibody is covalently attached to the bead. In another embodiment, the covalent attachment is a carbodimide bond.

5 **[0015]** In another aspect, the present invention provides a kit for conducting an immunoassay to detect A β ₄₂ peptide, the kit comprising a modified A β ₄₂ peptide of the present invention.

BRIEF DESCRIPTION OF THE TABLES

10 **[0016]**

Table 1 shows the desirable physical properties of the A β peptides and the tests used to measure those properties.

Table 2 shows A β ₄₂ peptide and modified peptide sequences and descriptions.

Table 3 shows tau peptide and modified peptide sequences and descriptions.

15 Table 4 shows the measured concentration of A β ₄₂ peptide in three human cerebrospinal (CSF) samples.

Table 5 shows a list of the novel A β peptides that were characterized.

Table 6 shows a summary of dynamic light scattering (DLS) data.

BRIEF DESCRIPTION OF THE FIGURES

20

[0017]

Figure 1 shows a schematic of a two-sided or sandwich soluble standard.

Figure 2 shows a calibration curve from an exemplary A β ₄₂ sandwich immunoassay.

25 Figure 3 shows an exemplary A β ₄₂ sandwich assay using modified A β ₄₂ peptide standards.

Figure 3A shows a calibration curve from modified standard 2 (SEQ ID NO:2) and 4 (SEQ ID NO:4).

Figure 3B shows a calibration curve from modified standard 12 (SEQ ID NO:12) and 13 (SEQ ID NO:13).

Figure 3C shows a calibration curve from modified standard 14 (SEQ ID NO:14) and 6 (SEQ ID NO:6).

Figure 4 shows a schematic of the A β ₄₂ intra-assay bead approach.

30 Figure 5A shows the measured Median Fluorescence Intensity (MFI) of 6 different Luminex bead sets covalently coupled with different concentrations of AP 1-40 peptide (SEQ ID NO: 15).

Figure 5B shows 4-PL generated calibration curves from either the A β ₄₀ intra-assay standards (circles) or from native A β ₄₂ peptides as a soluble standard (triangles), similar to the curve shown in Figure 2.

35 Figure 5C shows the measured A β ₄₂ peptides in human CSF samples using either a calibration curve generated from soluble A β ₄₂ peptides or from the intra-assay A β ₄₀ standards.

Figure 6 shows the levels of phosphorylated insulin growth factor receptor 1 (IGF-R1) in human peripheral blood mononuclear cell lysates. A 4 parameter calibration curve was generated from the MFI values on the different bead sets (Figure 6A) and used to determine the relative levels of phosphorylated IGF-R1 in PBMC lysates (Figure 6B).

Figure 7 shows DLS data.

40 Figure 8 shows circular dichroism analysis.

Figure 9 shows peptide stability data. The full length A β ₄₂ and seven modified peptides were subjected to stability studies at different temperatures for up to 40 days (Figures 9A-9F).

Figure 10 shows a standard curve comparison between full length A β ₄₂ and seven modified peptides.

Figure 11 shows the standard curve analysis of full length versus modified peptides.

45 Figure 12 shows a CSF sample analysis using full length versus modified peptides.

Figure 13 shows the structures of the polyethylene glycol spacers incorporated into the modified A β ₍₁₋₄₂₎ peptides.

DETAILED DESCRIPTION OF THE INVENTION

50 **[0018]** The present invention may be understood more readily by reference to the following detailed description of the preferred embodiments of the invention and the Examples included herein.

[0019] This invention relates to novel modified A β ₄₂ peptides that can be used as reference standards and calibrators in order to measure clinical biomarkers in an immunoassay. This invention also relates to methods of using the modified A β ₄₂ peptides and kits comprising the modified A β ₄₂ peptides. Specifically, the modified A β ₄₂ peptides and methods of the present invention are aimed at creating non-aggregating peptide reference standards for A β ₄₂ for use in immunoassay formats.

[0020] This invention also relates to kits comprising the modified A β ₄₂ peptides of the invention.

Definitions

[0021] As used herein, the term "A β " refers to amyloid beta.

[0022] As used herein, the term "A β_{42} " refers to Amyloid Beta 1-42. "A β_{42} " refers to a 42 amino acid length peptide that has an amino acid sequence as noted in Table 2, SEQ ID NO:1.

[0023] As used herein, the term "A β_{38} " refers to Amyloid Beta 1-38. "A β_{38} " refers to a 38 amino acid length peptide that has the sequence

DAEFRHDSGYEVHHQKLVFFAEDVGSNKGAIIGLMVGG (SEQ ID NO:17).

[0024] As used herein, the term "A β_{40} " refers to Amyloid Beta 1-40. "A β_{40} " refers to a 40 amino acid length peptide that has the sequence as noted in Table 2, SEQ ID NO:15.

[0025] As used herein, the term "tau" refers to the native tau protein corresponding to the amino acid sequence as noted in Table 3, SEQ ID NO:20.

[0026] As used herein, the term "antibody" is used in the broadest sense, and specifically covers monoclonal antibodies (including full length monoclonal antibodies), polyclonal antibodies, multispecific antibodies (*i.e.*, bispecific antibodies), and antibody fragments (*i.e.*, Fab, F(ab')₂ and Fv) so long as they exhibit binding activity or affinity for a selected antigen. "Antibody" can also refer to an antibody or antibody fragments hanging or fused to carrier proteins/organisms such as phage or other display carriers that have the same properties as isolated antibodies.

[0027] As used herein, the term "isolated", as used herein with reference to the subject proteins and protein complexes, refers to a preparation of protein or protein complex that is essentially free from contaminating proteins that normally would be present with the protein or complex (*i.e.*, in the cellular milieu in which the protein or complex is found endogenously). Thus, an isolated protein complex is isolated from cellular components that normally would "contaminate" or interfere with the study of the complex in isolation, for instance while screening for modulators thereof. It is to be understood, however, that such an "isolated" complex may incorporate other proteins the modulation of which, by the subject protein or protein complex, is being investigated.

[0028] As used herein, the term "isolated" as also used herein with respect to nucleic acids, such as DNA or RNA, refers to molecules in a form which does not occur in nature. Moreover, an "isolated nucleic acid" is meant to include nucleic acid fragments which are not naturally occurring as fragments and would not be found in the natural state.

[0029] As used herein, the term "nucleic acid" refers to polynucleotide such as deoxyribonucleic acid (DNA), and, where appropriate, ribonucleic acid (RNA). The term should also be understood to include, as equivalents, analogs of either RNA or DNA made from nucleotide analogs, and, as applicable to the embodiment being described, single-stranded (such as sense or antisense) and double-stranded polynucleotide. "Nucleic acid" can also refer to a peptide nucleic acid "PNA" or an artificially synthesized DNA or RNA.

[0030] As used herein, the terms "peptides", "proteins" and "polypeptides" are used interchangeably herein. The term "purified protein" refers to a preparation of a protein or proteins that are preferably isolated from, or otherwise substantially free of, other proteins normally associated with the protein(s) in a cell or cell lysate. As used herein, the term "modified peptide" refers to a peptide that has been modified relative to the native sequence of that peptide. For example, a modification may include the removal of a deleterious domain or the addition of a linker within the native peptide sequence.

[0031] As used herein, the term "binding" refers to a direct association between two molecules, due to, for example, covalent, electrostatic, hydrophobic, ionic and/or hydrogen-bond interactions under physiological conditions. Likewise, "complex formation," between two or more polypeptides, refers to a direct association between polypeptides, due to, for example, covalent, electrostatic, hydrophobic, ionic and/or hydrogen-bond interactions under physiological conditions.

[0032] As used herein, the term "domain" refers to a region of a protein that comprises a particular structure and/or performs a particular function (*i.e.*, aggregation domain, "phosphorylation domain"). The term "aggregation domain" as used herein refers to a five amino acid region located at amino acids 16 to 20 (KLVFF (SEQ ID NO:18)) which mediates the binding of A β peptides in an anti-parallel manner.

[0033] As used herein, the term "immunoreactive domain" refers to a region of a protein that comprises a particular amino acid sequence that can be recognized by an antibody. This region includes amino acid sequences that contain modifications such as glycosylation, methylation, phosphorylation or any other post-translational modification known to one of ordinary skill in the art. Examples of amino acids that could be phosphorylated are tyrosine, serine, or threonine amino acids. An "immunoreactive domain" that includes amino acids that are phosphorylated would also be characterized as a phosphorylation domain. An "immunoreactive" domain would also include two or more regions of a protein that are in close proximity to one another in the proteins native folded state, which together comprise an antibody binding site.

[0034] As used herein, the term "immunoassay" as used herein refers to a biochemical test that utilizes one or more antibodies to measure the presence or concentration of an analyte in a biological matrix. This assay can produce a measurable signal in response to a specific binding of an antibody to an immunoreactive domain of a specific protein or peptide.

Reference Standards

[0035] In one aspect, this invention relates to compositions comprising a modified A β ₄₂ peptide that can be used as reference standards and calibrators in order to measure clinical biomarkers. The modified peptide may comprise a linker in a non-immunoreactive domain. The non-immunoreactive domain is an aggregation domain.

Alterations in the Aggregation or Non-immunoreactive Domain

[0036] In one aspect, the present invention provides modified peptides which can be used as reference standards. There are known domains or amino-acid sequences which lead to the self-aggregation and non-specific interactions of sticky peptides like A β ₄₂ with itself and other molecules. As such, it is possible to construct standards or calibrators which lack these deleterious domains. One way to modify peptides in order to remove the deleterious domains is deleting the deleterious domains from the amino acid sequence so that, in the case of A β ₄₂, the N-terminal immunoreactive domain is connected to the C-terminal immunoreactive domain, and the central 17-20 amino acid sequence as well as various lengths of adjacent C-terminal peptide are lacking. Examples of A β ₄₂ peptides with the central domains deleted are shown in Table 2, SEQ ID NOs:2, 3, and 4. According to the present invention, the central aggregation domain plus the adjacent amino acids are replaced with a linker.

[0037] In one embodiment, amino acids that do not aggregate are contemplated as the linker. In one embodiment, the amino acids that do not aggregate are in the form of a hydrophilic spacer or linker of the amino acid sequence or form EERP, shown with both the C-terminal 37-42 sequences of A β ₄₂ (SEQ ID NO:5) and the C-terminal 32-42 portions of A β ₄₂ (SEQ ID NO:6). In another embodiment, the A β ₄₂ peptide includes a longer hydrophilic linker, for example the amino acid sequence DREPNR (SEQ ID NO:16), with both the C-terminal 37-42 (SEQ ID NO:7) and C-terminal 32-42 (SEQ ID NO:8) portions of A β ₄₂.

[0038] In yet another embodiment, a series of charged residues are used in the form of the linker between the N-terminal and C-terminal immunoreactive domains. In another embodiment, a linker is created consisting of an integer number m Lysine residues (SEQ ID NO:9) or integer number n Glutamic acid residues (SEQ ID NO:10). In another embodiment, a string of neutral residues is used as a linker. In another embodiment, a construct consisting of an integer number p alanine residues (SEQ ID NO: 11) is contemplated.

[0039] In another embodiment of the present invention, various forms of polyethylene glycol (PEG) are used as a linker. In a preferred embodiment, PEG-6atom and PEG-20atom are used with various C-terminal portions (SEQ ID NOs:12-14). In another embodiment, a dendrimer or branched co-polymer with chemistry able to couple to amino acid residues is used as a linker. These polymers of known branched topology simulate the immunoreactivity of oligomers of A β ₄₂ and other similar sticky or self aggregating molecules.

[0040] In one embodiment, the construct does not lead to self aggregation or non specific absorption to laboratory plastics, in particular polypropylene, polystyrene, polycarbon and other laboratory plastic resins of which pipette tips, tubes, plates and other vessels which hold fluids in which the analyte of interest can be measured.

[0041] The novel A β ₄₂ immunoassay standards or calibrators require the presence of the N-terminal epitope that is recognized by the N-terminal specific antibody. There are many A β ₄₂ N-terminal binding antibodies that are known in the art. For example, 6E10 is known to recognize the A β ₃₋₈ epitope whereas 3D6 is known to recognize the N-terminal epitope of A β . An overlapping epitope may be designed to allow a selection of several N-terminal specific antibodies to be used, depending on the immunoassay requirements and detection system.

[0042] Further, the novel A β ₄₂ immunoassay standards or calibrators require the presence of the C-terminal epitope that is recognized by the C-terminal A β ₄₂ specific antibody. Examples of well characterized C-terminal A β ₄₂ neo-epitope antibodies include G2-11 (from Heidelberg University), 21F12 (from Athena Diagnostics), 4D7A3 (from Innogenetics), and 12F4 (from Covance, formerly Signet). An overlapping c-terminal epitope may be designed to allow a selection of several C-terminal A β ₄₂ specific antibodies to be used, depending on the immunoassay requirements and detection system.

[0043] Further described herein are methods for generating a peptide or protein construct and compositions thereof that can be used as a reference standard or calibrator in an immunoassay to measure the abundance of a peptide accurately in a fluid or tissue extract sample. An immunoassay often requires biologically specific capture reagents, such as antibodies, to capture the analytes or biomarkers of interest. Antibodies can be produced by methods well known in the art, *i.e.*, by immunizing animals with the biomarkers as antigens. Biomarkers can be isolated from samples based on their binding characteristics. Alternatively, if the amino acid sequence of a polypeptide biomarker is known, the polypeptide can be synthesized and used to generate antibodies by methods well known in the art. The biomarkers are A β peptides.

[0044] This invention contemplates traditional immunoassays including, for example, sandwich immunoassays including ELISA or fluorescence-based immunoassays, as well as other enzyme immunoassays. In the SELDI-based immunoassay, a biospecific capture reagent for the biomarker is attached to the surface of a mass spectrometry (MS) probe,

such as a pre-activated PROTEINCHIP® array. The biomarker is then specifically captured on the biochip through this reagent, and the captured biomarker is detected by mass spectrometry.

[0045] Thus, in one aspect, the invention relates to methods of measuring the clinical markers with the reference standards of the invention. In one embodiment, the reference standard is measured by immunoassay. In another embodiment, the immunoassay is a sandwich immunoassay. In another embodiment, the immunoassay is a single antibody immunoassay, often run in a competitive or "competition" mode for immunoreactive binding sites. In yet another embodiment, the immunoassay is a double sandwich immunoassay or enzyme linked immunosorbant assay (ELISA).

[0046] In a preferred embodiment, the method of measuring the clinical markers is by using an immunoassay comprising the steps of attaching a reference standard to at least two beads thereby forming a first bead set and a second bead set, wherein the reference standard comprises an epitope recognized by a first detection antibody and wherein each bead set comprises a different concentration of the reference standard; attaching a capture antibody specific to the A β peptide analyte to a third bead set; mixing all of the bead sets together to form a suspension array; applying the biological sample to the suspension array whereby the analyte binds to the capture antibody on the third bead set; adding a first detection antibody to the suspension array, wherein the first detection antibody binds the reference standard and analyte bound to the capture antibody; measuring a first signal from the first detection antibody bound to the reference standard in the first bead set; measuring a second signal from the first detection antibody bound to the reference standard in the second bead set; generating a standard curve based upon the first and second signals; and quantitating the amount of the analyte in the third bead set by measuring a third signal from the first detection antibody and comparing the third signal to the first and second signal measurements on the standard curve. It is understood without limitation to the present invention that a bead set could be replaced by any other solid phase in which multiplexed information can be measured independently in a particular detection technology or instrument.

[0047] The reference standard comprises a modified A β_{42} peptide described herein. In one embodiment, the biological sample is selected from the group consisting of blood, serum, plasma, peripheral blood mononuclear cells, peripheral blood lymphocytes tissue, cerebrospinal fluid and cells. The A β peptide analyte is A β_{42} , A β_{40} , or A β_{38} .

[0048] The analyte and/or reference standard may be bound to a variety of surface. A surface could be any solid phase surface to which an antibody or reference standard can be immobilized by covalent linkage, passive absorbance, biotin-streptavidin or any other linkage known to one of ordinary skill in the art. For example, the surface may be a bead, plate, slides, fiber, surface plasmon resonance sensors or any solid surface.

[0049] In another embodiment, the method is performed in a multi-well plate, nitrocellulose filter or on a glass slide. In another embodiment, the first and second signals are detected by fluorescence. For example, the first signal and second signal may be a signal selected from the group consisting of phycoerythrin, alexa 532, streptavidin-phycoerythrin and streptavidin-Alexa 532. In another embodiment, the signal is detected by enzymatic activity (*i.e.*, horseradish peroxidase or alkaline phosphatase), chemiluminescence, radioactivity, infra-red emission, fluorescence resonance energy transfer (FRET) or any other method known to one of ordinary skill in the art.

[0050] In another aspect, the invention comprises a kit for conducting an immunoassay to detect an A β_{42} peptide, the kit comprising a reference standard of the invention.

Performance Comparison of Novel Immunoassay Standard or Calibrator to Native A β_{42}

[0051] The performance of novel immunoassay standards or calibrators should have comparable performance to the native A β_{42} in an immunoassay. Native full length A β_{42} peptides may be synthesized using standard solid phase techniques or they may be purchased commercially from a number of vendors as a catalog item (Anaspec Inc., American Peptide Company, or Invitrogen Inc.). Standard methods can be used to verify the abundance of the full length construction from truncated species using mass spectrometry techniques such as amino acid analysis that are well known in the field (Kanu et al., Journal of Mass Spectrometry, 43:1-22 (2008); Bernstein et al., Journal of American Chemical Society, 127:2075-2084 (2005); Li et al., Encyclopedia of Analytical Chemistry, Meyers, R.A., ed., John Wiley & Sons Ltd. (2009)).

[0052] By way of example, Table 1 lists the desirable physical properties of A β_{42} peptides and the various methods used to test these properties. These methods can be employed to determine if the properties of the reference standard are comparable to those of the native A β_{42} peptide.

TABLE 1

Property	Test	Target Range	Reference
Solubility	SDS-PAGE	Greater than 90% monomeric form	Analy. Biochem., 316:223-231 (2003)

(continued)

Property	Test	Target Range	Reference
	Dynamic light scattering	Less than 5% aggregated peptides	Meth. Enzymology, 309:429-459 (1999); J. Biol. Chem., 274:25945-25952 (1999)
Non-specific adsorption	Spike recovery into CSF or buffer A β_{42} immunoassay	Recovery between 80 and 120%	A β Immunoassay Olsson et al., Clinical Chemistry, 51:336-345 (2005)
Aggregation	SDS-PAGE Western blotting	Greater than 90% monomeric form	PNAS, 100:330-335 (2003); Analy. Biochem., 316:223-231(2003)
	Thioflavin T assay	Greater than 90% monomeric form	Meth. Enzymology, 309:274-284 (1999)
Fibril formation	Microscopy (transmission electron microscopy, optical, Microscopy (optical, atomic force)	Minimal levels of observable oligomers or fibrils	Protein Pep. Letters, 13:261-270 (2006); J. Am. Chem. Soc., 125:15359-15365 (2003)
Stability at 25 °C, -20 °C, and -80 °C	Less than 20% CV loss of signal compared to <i>freshly</i> prepared A β_{42} Via A β_{42} immunoassay	2 hrs 25 °C 3 months -20 °C, 6 months -80 °C	Olsson et al., Clinical Chemistry, 51:336-345 (2005); Verwey et al., Journal of Immunological Methods, 348:57-66 (2009)

Use of Modified Reference Standards or Calibrators in Antibody Based Immunoassays

[0053] In another aspect of the present invention, the modified reference standard is used in a single antibody based assay. In one embodiment, immunoassays containing a single antibody can be used to measure A β_{42} in a biological sample by a competition immunoassay. A single antibody specific to A β_{42} is immobilized to a solid surface such as the well of a microtiter plate, a bead, or other immunoassay relevant surface. The antibody may be covalently linked via many different methods such as EDC mediated linkage of carboxyl and amine groups, or via passive absorbance or through a Protein A or Protein G interface. An A β_{42} competitor is then generated from an A β_{42} standard or calibrator containing the full length A β_{42} peptide or a modified version that retains the epitope of the capture antibody. The A β_{42} competitor is used to generate competition between the native A β_{42} in the biological sample and the binding site (paratope) on the immobilized antibody. A paratope is a term used to describe the binding region on the antibody that recognizes the epitope or immunoreactive domain on the analyte. The A β_{42} competitor is tagged for detection purposes. In one embodiment, the tag is an enzyme such as horseradish peroxidase or alkaline phosphatase. In another embodiment, the tag is a fluorescein such as phycoerythrin. In yet another embodiment, the tag is another tag such as biotin or ruthenium. In yet another embodiment, the tag is a nucleic acid such as DNA, RNA or PNA, where by detection of the antibody is quantitated using sensitive technology to detect the nucleic acid flag, such as Polymerase Chain Reaction (PCR). A single concentration of the A β_{42} competitor is used in the assay and would be determined based on the ability to compete with the natural levels of A β_{42} found in biological samples.

[0054] In another embodiment, the assay is made quantitative by establishing a calibration curve. In another embodiment, quantitation is performed by making a set of A β_{42} standards or calibrators that are either the full length A β_{42} peptide or a modified version that retains the epitope of the capture antibody. These untagged standards or calibrators are prepared in either buffer or a biological matrix that does not contain A β_{42} . In one embodiment, the calibration curve is established by mixing one of concentrations of the untagged standards or calibrators with the tagged A β_{42} competitor to the immobilized antibody. The resulting signal value from each tested concentration of untagged standard or calibrator is used to generate a standard curve; plotting the concentration of the untagged A β_{42} standards or calibrators versus the resulting signal values. Once a standard quantitative curve is established, an assay is used to determine the levels of native A β_{42} in biological samples by mixing the tagged A β_{42} competitor at the same fixed concentration with the biological sample. The resulting signal value is plotted on the standard curve to determine the level of A β_{42} in the biological sample.

[0055] In another aspect of the present invention, the modified reference standard is used in a sandwich based immunoassay.

Use of Modified Standards or Calibrators in Intra-assay Reference Standard Based Immunoassays

[0056] In another aspect of the present invention, A β ₄₂ peptides are incorporated into an intra-assay calibration system. In this approach, a multiplex immunoassay format such as the Luminex bead based system or the Meso-Scale Discovery ECL plate based system could be used. Peptides containing amino acid residues that encompass the antibody binding epitope of the detection antibody are generated. In one embodiment, these peptides include modifications that enable them to be covalently coupled to a solid phase or modifications that increase their solubility and use in aqueous immunoassays. These peptides are immobilized at different concentrations to the relevant solid phase as defined by multiplexed immunoassay systems, in order to create a set of well defined standards from which to create a standard curve.

[0057] The measurement of soluble biomarkers in clinical samples is often done using double antibody sandwich assays. These assays require two antibodies that are specific to the biomarker and a technology in which to detect the captured biomarker using the second "reporter" or "detection" antibody. Protein reference standards are required in order to make the assay quantitative. These standards are often in the form of recombinant proteins; however, they may also be obtained from biological samples. Traditional assay formats for these assays include ELISA techniques that provide quantitation suitable for the analysis of clinical samples. However, they are often limited to one biomarker assay per well. Newer technologies have been developed that allow multiple biomarkers to be analyzed in a single well or reaction vessel. Some of the multiplexed technologies utilize antibodies spotted onto a solid surface such as glass slides or specialized microtiter plates. Another approach is via suspension arrays where the antibodies are bound to latex beads which are mixed together in solution to form the array.

[0058] In one embodiment, suspension array technology is used. In another embodiment, the suspension array technology is the Luminex xMAP technology. Luminex xMAP technology uses latex beads that contain a ratio of two fluorescent dyes. Different bead 'sets' are created by altering the ratio of these two dyes. The beads are mixed together to form a suspension array. The bead mixture is analyzed by an instrument that identifies each bead by the fluorescence ratio as it passes in front of a laser. These bead sets have different modifications on their surface that are used for the covalent attachment of molecules such as proteins, peptides, antibodies, etc. This allows assay to be performed on the surface of these beads. Assays are quantitated through the incorporation of a third fluorescent label such as phycoerythrin to a reporter antibody directed at the analytes of interest. A second laser in the instrument measures the fluorescence of this reporter label as the beads move through the instrument.

EXAMPLES

EXAMPLE 1 - SANDWICH BASED ASSAY THAT CAN BE USED TO MEASURE A β ₄₂

[0059] A schematic of a two-sided or sandwich soluble standard is shown in Figure 1. Briefly, capture antibodies specific to the C-terminus of A β ₄₂ were immobilized to a solid surface. A biological sample was added thereby allowing A β ₄₂ to be captured by the immobilized antibody. A second tagged detection antibody was added that was specific to the N-terminus of the A β ₄₂. The measured signal generated by the tagged detection antibody was used for quantitation.

[0060] An example of a sandwich assay that can be used to measure A β ₄₂ is shown in Figure 2. Briefly, a biotin labeled anti-C-terminal A β ₄₂ antibody (565) was immobilized to a 96 well Meso-Scale Discovery streptavidin coated plate (MesoScale Discovery Inc., Gaithersburg, Maryland ((MSD)). Reference standard A β ₄₂ peptides (full length with native sequence) were added to different wells. A β ₄₂ peptides were captured by the immobilized capture antibody. A second ruthenium tagged (Ru) antibody to the N-terminus of A β ₄₂ (26D6) was added, completing the sandwich. The complex was detected using an MSD sector 6000 instrument using ECL. The raw fluorescence units (RFU) measured by the instrument were fit to a 4-parameter logistic model to create a standard curve. In another example, several modified A β ₄₂ peptides are used as a reference standard (Table 2, SEQ ID NOs:2, 4, 6, 12, 13, and 14). The standard curves generated by these modified calibrators are shown in Figure 3.

TABLE 2: A β ₄₂ Peptide and Modified Peptide Sequences and Descriptions

Peptide/Modified Peptide Sequence	Description of Peptide/Modified Peptide Sequence
DAEFRHDSGYEVHHQKLVFFAEDVGSNKGAI	native A β ₄₂ sequence
GLMVGGVVIA (SEQ ID NO:1)	
DAEFRHDSGYEVMVGGVVIA (SEQ ID NO:2)	native A β ₄₂ amino acids (1-14)(35-42) with no spacer in between

EP 2 534 490 B1

(continued)

	Peptide/Modified Peptide Sequence	Description of Peptide/Modified Peptide Sequence
5	DAEFRHDSGYEVHHQKGGVVIA (SEQ ID NO:3)	native A β ₄₂ amino acids (1-16)(37-42) with no spacer in between
	DAEFRHDSGYEVHHQKIGLMVGGVVIA (SEQ ID NO:4)	native A β ₄₂ amino acids (1-16)(32-42) with no spacer in between
10	DAEFRHDSGYEVHHQKEERPGGWIA (SEQ ID NO:5)	native A β ₄₂ amino acids (1-16)-EERP-native A β ₄₂ amino acids (37-42)
	DAEFRHDSGYEVHHQKEERPIGLMVGGWIA (SEQ ID NO:6)	native A β ₄₂ amino acids (1-16)-EERP-native A β ₄₂ amino acids (32-42)
15	DAEFRHDSGYEVHHQKDREERPGGVVIA (SEQ ID NO:7)	native A β ₄₂ amino acids (1-16)-DREERP hydrophilic linker-native A β ₄₂ amino acids (37-42)
20	DAEFRHDSGYEVHHQKDREPNRIGLMVGGV IA (SEQ ID NO:8)	native A β ₄₂ amino acids (1-16)-DREPNR hydrophilic linker-native A β ₄₂ amino acids (32-42)
	(1-16)-(Lys) <i>m</i> -(37-42) (SEQ ID NO:9)	native A β ₄₂ amino acids (1-16)- up to 20 Lysine residues- native A β ₄₂ amino acids (37-42)
25	(1-16)-(Glu) <i>n</i> -(37-42) (SEQ ID NO:10)	native A β ₄₂ amino acids (1-16)- up to 20 Glutamic acid residues-native A β ₄₂ amino acids (37-42)
30	(1-16)-(Ala) <i>p</i> -(37-42) (SEQ ID NO:11)	native A β ₄₂ amino acids (1-16)- up to 20 Alanine residues- native A β ₄₂ amino acids (37-42)
35	DAEFRHDSGYEVHHQK- <u>PEG(20-ATOMS)3</u> - GGVVIA (SEQ ID NO:12)	native A β ₄₂ amino acids (1-16)-(PEG_20)3 linker- native A β ₄₂ amino acids (37-42)
	DAEFRHDSGYEVHHQK- <u>PEG(9-ATOMS)6</u> - MVGGVVIA (SEQ ID NO:13)	native A β ₄₂ amino acids (1-16)-(PEG_9)6 linker- native A β ₄₂ amino acids (35-42)
40	DAEFRHDSGYEVHHQK- <u>PEG(9-ATOMS)5</u> - IGLMVGGVVIA (SEQ ID NO:14)	native A β ₄₂ amino acids (1-16)-PEG_9)5 linker- native A β ₄₂ amino acids (32-42)
	(X-Y) -Linker-(Z-42)	Generic: X,Y,Z, Linker to be specified
45	DAEFRHDSGYEVHHQKLVFFAEDVGSNKGAI GLMVGGVV (SEQ ID NO:15)	A β ₄₀ native sequence

50 [0061] An immunoassay can also be used to measure tau. Examples of modified tau peptide sequences that can be used as reference standards are depicted below in Table 3.

55

EP 2 534 490 B1

TABLE 3: Tau Peptide Sequences and Constructs

Peptide/Modified Peptide Sequence	Description of Peptide/Modified Peptide Sequence
5 MAEPRQEFVEMEDHAGTYGLGDRKDQGGYTMHQDQ EGDTDAGLKESPLQPTEDGSEEPGSETSDAKSTPTAE DVTAPLVDEGAPGKQAAAQPHTEIPEGTTAEEAGIGDT 10 PSLEDEAAGHVTQARMVSKSKDGTGSDDKKAKGADG KTKIATPRGAAPPGQKQANATRIPAKTPPAPKTPPSSG EPPKSGDRSGYSSPGSPGTPGSRSRTPSLPTPPTREPKKV 15 AVVRTPPKSPSSAKSRLQTAPVMPDLKNVSKIGSTE NLKHQPGGGKVQIINKKLDLSNVQSKCGSKDNIKHVP GGGSVQIVYKPVDLSKVTSKCGSLGNIHHKPGGGQVE 20 VKSEKLDKDRVQSKIGSLDNITHVPGGGNKKIETHKL TFRENAKAKTDHGAEIVYKSPVVSGDTSRHLNSVSST GSIDMVDSPLATLADEVASLAKQGL (SEQ ID NO:20)	native tau sequence
25 EVMEDHAGTYGL-generic linker-GAAPPGQKQAN (SEQ ID NO:21)	native tau amino acids (9-20)-generic linker-native tau amino acids (156 -167)
30 EVMEDHAGTYGL-generic linker-SGDRSGYSSP (SEQ ID NO:22)	native tau amino acids (9-20)-generic linker-native tau amino acids-(191-200)
35 GAAPPGQKQAN-generic linker-IPAKTPPAPKT _(P04) PPSSGEPPK (SEQ ID NO:23)	native tau amino acids (156 -167)-generic linker- native tau amino acids (171-190); amino acid T ¹⁸⁰ is phosphorylated
40 GAAPPGQKQAN-generic linker-REPKKVAVVRT _(P04) PPKSPSSAK (SEQ ID NO:24)	native tau amino acids (156-167)-generic linker-native tau amino acids (221-240); amino acid T ²³¹ is phosphorylated
45 GAAPPGQKQAN-generic linker-SGDRSGYSSP (SEQ ID NO:25)	native tau amino acids (156-167)-generic linker-native tau amino acids (191-200)
50 IPAKTPPAPKT _(P04) PPSSGEPPK-generic linker-SGDRSGYSSP (SEQ ID NO:26)	native tau amino acids (171-190)-generic linker-native tau amino acids (191-200); amino acid T ¹⁸⁰ is phosphorylated
55 SGDRSGYSSP-generic linker-REPKKVAVVRT _(P04) PPKSPSSAK (SEQ ID NO:27)	native tau amino acids (191-200)-generic linker-native tau amino acids (221-240); amino acid T ²³¹ is phosphorylated

EXAMPLE 2 - SANDWICH A β ₄₂ ASSAY MEASURING A β ₄₂ IN BIOLOGICAL SAMPLES

[0062] An example of a sandwich A β ₄₂ assay measuring A β ₄₂ in biological samples is shown in Table 3. Biotin labeled anti-C-terminal A β ₄₂ antibody (565) was immobilized to a 96 well MSD streptavidin coated plate. Reference standard A β ₄₂ peptides (full length with native sequence) or a modified A β ₄₂ reference standard (SEQ ID NO:2) were added to

EP 2 534 490 B1

different wells. Human CSF samples at different dilutions were placed in different wells. The plate was incubated 2 hours at room temperature to allow A β ₄₂ peptides to be captured by the immobilized capture antibody. A second ruthenium tagged (Ru) antibody to the N-terminus of A β ₄₂ (26D6) was added, completing the sandwich. The complex was detected using an MSD sector 6000 instrument using ECL. The raw fluorescence units (RFU) measured by the instrument were fit to a 4-parameter logistic model to create a standard curve. The measured concentrations of A β ₄₂ in human CSF samples are shown in Table 3.

TABLE 4: Measured Concentration of A β ₄₂ Peptide in Three Human Cerebrospinal (CSF) Samples

CSF sample	CSF dilution	A β ₄₂ Concentration (pg/ml)	
		Full length A β 1-42 Peptide	Modified A β xx-42 peptide
CSF-1	1:2 dil	Below limit of detection	Below limit of detection
CSF-1	1:4 dil	Below limit of detection	Below limit of detection
CSF-2	1:2 dil	26.2	27.8
CSF-2	1:4 dil	54.0	56.8
CSF-3	1:2 dil	88.4	80.4
CSF-3	1:4 dil	134.4	126.4

EXAMPLE 3 - A β PEPTIDE BASED INTRA-ASSAY LUMINEX ASSAY

[0063] Figure 4 shows a schematic of the A β ₄₂ intra-assay bead approach. Bead sets coupled with different concentrations of A β ₄₂ standard peptides (or other native or modified A β peptides) are combined with a bead set coupled with an anti-A β ₄₂-C-terminal specific capture antibody to form a suspension array. The array is incubated with a biological sample, where the A β ₄₂ peptide in the biological sample is captured by the bead coupled with anti-A β ₄₂ capture antibody. A tagged detection antibody specific to the N-terminus of the A β ₄₂ peptide is added to the suspension array, thereby binding to the captured A β ₄₂ peptide and also to the beads that have A β ₄₂ peptides coupled to their surface. The MFI values obtained from the beads with A β ₄₂ peptides coupled to their surface is used to generate an intra-assay calibration curve. The amount of A β ₄₂ in the biological sample is determined from the amount of captured A β ₄₂ on the bead coupled with the anti-A β ₄₂ capture using the intra-assay standard curve.

Antibodies and Reference Standards

[0064] The native full length A β ₄₂ and full length A β ₄₀ peptides (SEQ ID NOs: 1 and 15, respectively) were obtained from American Peptide Company. The 116B565.1 mouse anti-human A β ₄₂ C-terminus antibody and the 26D6-B2-B3 mouse anti-human A β ₄₂ N-terminus antibody were obtained via protein-G purification of culture supernatants produced by the relevant BMS owned hybridoma cell lines.

[0065] Phycoerythrin-streptavidin conjugate was obtained from Jackson ImmunoResearch (West Grove, PA). Tween-20, 1-ethyl-3-[3 dimethylaminopropyl] carbodiimide hydrochloride (EDC), sodium azide, IgG free Bovine Serum Albumin (BSA), and sodium phosphate were purchased from Sigma-Aldrich Corporation (St. Louis, MO). Phosphate buffered saline (PBS) was obtained from Mediatech Incorporated (Herndon, VA). Carboxylated Luminex beads were purchased from Bio-Rad Incorporated (Hercules, CA). Phycoerythrin label goat anti-mouse IgG antibody was obtained from Jackson ImmunoResearch (West Grove, PA).

Covalent Coupling of Anti-A β ₄₂ Capture Antibody to Luminex Beads

[0066] The 116B565.1 mouse anti-human A β ₄₂ C-terminus antibody was covalently coupled to the surface of carboxylated beads using a two-step carbodiimide procedure. The beads were washed by centrifuging 1.25×10^7 beads for 5 min at $14000 \times g$ $4^\circ C$ in an Eppendorf 5415D centrifuge (Westbury, NY). The supernatant was carefully removed and another 1.25×10^7 beads were dispensed and centrifuge for 5 min at $14000 \times g$ $4^\circ C$. The supernatant was again carefully removed and resuspended in 800 μ l of 0.1M sodium phosphate buffer pH 4.8 (activation buffer). The beads were then vortexed for 15 seconds and sonicated for 15 seconds using a SPER SCIENTIFIC® LTD Ultrasonic Cleaner (Scottsdale, AZ). The beads were washed 2 additional times with activation buffer, and resuspended in 200 μ l of freshly prepared 5 mg/ml EDC prepared in activation buffer. The beads were incubated in a rotator for 20 min RT protected from light. At the end of the EDC step, the beads were washed and resuspended in 1000 μ l of 250 μ g/ml capture antibody prepared in PBS and incubated for 1hrs RT in a rotator protected from light. The beads were washed and incubated with 1 ml of

EP 2 534 490 B1

blocking buffer (PBS, 1% (w/v) BSA, 0.02% (w/v) Tween-20) in a rotator for 1 hr RT protected from light. Finally, the beads were counted with a hemacytometer, resuspended in blocking buffer at 2×10^6 beads/ml, and stored protected from light at 4 °C until ready for use.

5 Surface Testing of Covalent Coupling Efficiency of A β ₄₂ Capture Antibodies to Luminex Beads

[0067] The presence of capture antibody on the bead surface was confirmed using surface testing. 50 μ l of assay buffer (PBS, 1% (w/v) BSA, 0.05% (w/v) Tween 20, 0.05% (w/v) azide) containing 2500 beads were added to Millipore filter bottom plate wells (Bedford, MA). The beads were washed by placing the plate over a Millipore vacuum manifold (Bedford, MA) to remove the liquid and then resuspended in 100 μ l/well of PBST wash buffer. Finally, the wash buffer was removed from the wells via vacuum and the beads were incubated with 100 μ l/well of PE-Goat anti-mouse IgG diluted 1/100 in assay buffer. The plate was incubated on a 96-well plate shaker (Lab Line Instruments, Melrose Park, IL) at 300 rpm for 30 min RT protected from light. The beads were subsequently washed 3 times via vacuum filtration using 100 μ l/well of wash buffer and resuspended in 100 μ l/well of assay buffer. The MFI of at least 50 beads/well was measured using a Luminex¹⁰⁰ instrument obtained from Bio-Rad Laboratories (Hercules, CA) running Bioplex manager 4.1.1 software. An MFI of at least 20,000 was used to confirm the presence of usable quantities of antibody on the bead surface.

20 Covalent Coupling of Intra-assay A β ₄₀ Peptides to Luminex Beads

[0068] A β ₄₀ native full length peptides (SEQ ID NO:15) were prepared by reconstituting the lyophilized peptide in 2.5 ml PBS to give a final concentration of 10mg/ml. A β ₄₀ peptides were selected for this assay in lieu of A β ₄₂ peptides because they still expressed the N-terminal A β ₄₂ epitopes needed for the binding of 26D6 antibodies and the A β ₄₀ peptides were more stable in aqueous buffers needed for conjugation. A β ₄₀ peptides were diluted to different concentrations (shown in Figure 5A) using diluent buffer (PBS, 1% (w/v) BSA, 0.02% (w/v) Tween-20). Each preparation of A β ₄₀ peptide was covalently coupled to the surface of a selected bead set (different bead set for each concentration) using a two-step carbodiimide procedure. Each bead set was washed by centrifuging 1.25×10^7 beads for 5 min at 14000 x g 4 °C in an Eppendorf 5415D centrifuge (Westbury, NY). The supernatant was carefully removed and 800 μ l of 0.1M sodium phosphate buffer pH 4.8 (activation buffer) was added. The beads were then vortexed for 15 seconds and sonicated for 15 seconds using a SPER SCIENTIFIC® LTD Ultrasonic Cleaner (Scottsdale, AZ). The beads were washed an additional time with activation buffer, and resuspended in 200 μ l of freshly prepared 5 mg/ml EDC prepared in activation buffer. The beads were incubated in a rotator for 20 min RT protected from light. At the end of the EDC step, each bead set was washed and resuspended with the predetermined concentrations of A β ₄₀ peptides and incubated for 1hr RT in a rotator protected from light. The bead sets were washed and incubated with 1 ml of blocking buffer (PBS, 1% (w/v) BSA, 0.02% (w/v) Tween-20) in a rotator for 1 hr RT protected from light. Finally, the concentration of each bead set preparation was assessed by counting the beads with a hemacytometer. Each bead set was then resuspended in blocking buffer at 2×10^6 beads/ml, and stored protected from light at 4 °C until ready for use.

40 Testing of A β ₄₀ Peptide Coupled Luminex Beads

[0069] The presence of A β ₄₀ peptides which contain the N-terminal epitopes for the A β ₄₂ N-terminal specific antibodies on the bead surface was confirmed using surface testing. 50 μ l of assay buffer (PBS, 1% (w/v) BSA, 0.05% (w/v) Tween 20, 0.05% (w/v) azide) containing 2500 beads were added to Millipore filter bottom plate wells (Bedford, MA). The beads were washed by placing the plate over a Millipore vacuum manifold (Bedford, MA) to remove the liquid and the beads were resuspended in 100 μ l/well of PBST wash buffer. Finally, the wash buffer was removed from the wells via vacuum and the beads were incubated with 100 μ l/well of biotin labeled 26D6-B2-B3 antibody diluted in assay buffer. The plate was incubated on a 96-well plate shaker (Lab Line Instruments, Melrose Park, IL) at 300 rpm for 30 min RT protected from light. Following the incubation step, the beads were washed 4 times, resuspended in 50 μ l/well of 1 μ g/ml of Phycoerthrin-streptavidin conjugate, and incubated on a plate shaker for 20 min at RT protected from light. The beads were subsequently washed 3 times via vacuum filtration using 100 μ l/well of wash buffer and resuspended in 100 μ l/well of assay buffer. The MFI of at least 50 beads/well was measured using a Luminex¹⁰⁰ instrument obtained from Bio-Rad Laboratories (Hercules, CA) running Bioplex manager 4.1.1 software. The MFI measured on each of the bead sets is shown in Figure 5A.

55 A β ₄₂ Intra-Assay Analysis of Biological Samples

[0070] Samples analysis using the intra-assay Luminex based assay was performed by first mixing bead sets that were coupled with anti-C-terminal specific A β ₄₂ 565 capture antibodies and bead sets that were coupled with different

EP 2 534 490 B1

concentrations of A β ₄₀ peptides (shown in Figure 5A). 50 μ l/well of the combined mixture of all bead sets at 50,000 beads/ml suspension prepared in assay buffer was added to each well of a pre-wet filter bottom 96-well plate. The beads were washed with 100 μ l/well of assay buffer via vacuum filtration. The capture beads were resuspended in 50 μ l of diluted human CSF samples, quality control samples (QC), different concentrations of full length native A β ₄₂ peptides as reference standards, or different concentrations of modified A β ₄₂ peptide standards in duplicate wells and incubated on a plate shaker for 1 hr at RT protected from light. 1.0 μ g/ml anti-A β ₄₂ 26D6 reporter antibody labeled with biotin was added and then incubated on a plate shaker for 0.5 hrs at RT protected from light. Following the incubation step, the beads were washed 4 times, resuspended in 50 μ l/well of 1 μ g/ml of Phycoerthrin-streptavidin conjugate, and incubated on a plate shaker for 20 min at RT protected from light. Finally, the beads were washed 4 times and resuspended in 100 μ l/well of assay buffer. The MFI of at least 50 beads per well was measured using a Bioplex Luminex instrument running Bioplex manager 5.1 software (Bio-Rad Laboratories, Hercules, CA). Standard curves were generated from the soluble A β ₄₂ peptides or from the signals generated from the bead sets coated with different concentrations of A β ₄₀ peptides (intra-standard) using a weighted 4-parameter logistic curve fit (Figure 5B). The concentration of A β ₄₂ peptides in the CSF or QC samples were calculated from the relevant standard curve, and are shown in Figure 5C.

REFERENCE EXAMPLE 4 - PEPTIDE BASED INTRA-ASSAY FOR IGFR1 WITH LUMINEX BEADS

[0071] Below is another example of a peptide intra-assay based assay for the detection of phosphorylated tyrosine residues, 1162 and 1163, on human IGF-R1 receptors. Phosphorylated regions of Tau may also be used in the same manner.

Antibodies and Reference Standards

[0072] A custom made IGF1R [PYPY^{1162/1163}] peptide was provided by Cambridge Research Biochemicals Ltd (UK). Mouse anti-IGF1R capture antibody was obtained from Calbiochem (San Diego, CA) and the rabbit anti-phospho-tyrosine (1162/1163) - IGF1R reporter antibody was purchased from Millipore (Billerica, MA). Phycoerythrin label goat anti-rabbit antibody was obtained from Jackson Immunoresearch (West Grove, PA). Tween-20, 1-ethyl-3-[3 dimethylaminopropyl] carbodiimide hydrochloride (EDC), sodium azide, IgG free Bovine Serum Albumin (BSA), and sodium phosphate were purchased from Sigma-Aldrich Corporation (St. Louis, MO). Phosphate buffered saline (PBS) was obtained from Mediatech Incorporated (Herndon, VA). Carboxylated Luminex beads were purchased from Bio-Rad Incorporated (Hercules, CA). Normal healthy PBMC samples were obtained from In house donors (BMS, NJ). The PBMC samples were treated with either PBS or 100ng/ml of purified human IGF1 (Genetex Inc, TX) for 10 min at 37 °C to induce phosphorylation of IGFR present on the cells. The cells were washed, lysed with a modified RIPA buffer, and stored at -80 °C.

Covalent Coupling of Anti-IGF-R1 Capture Antibody to Luminex Beads

[0073] The mouse anti-human IGF1R capture antibody was covalently coupled to the surface of carboxylated beads using a two-step carbodimide procedure. The beads were washed by centrifuging 1.25×10^7 beads for 5 min at 14000 x g 4 °C in an Eppendorf 5415D centrifuge (Westbury, NY). The supernatant was carefully removed and another 1.25×10^7 beads were dispensed and centrifuged for 5 min at 14000 x g 4 °C. The supernatant was again carefully removed and re-suspended in 800 μ l of 0.1M sodium phosphate buffer pH 4.8 (activation buffer). The beads were then vortexed for 15 seconds and sonicated for 15 seconds using a SPER SCIENTIFIC® LTD Ultrasonic Cleaner (Scottsdale, AZ). The beads were washed 2 additional times with activation buffer, and resuspended in 200 μ l of freshly prepared 5 mg/ml EDC prepared in activation buffer. The beads were incubated in a rotator for 20 min RT protected from light. At the end of the EDC step, the beads were washed and resuspended in 1000 μ l of 250 μ g/ml capture antibody prepared in PBS and incubated for 1hr RT in a rotator protected from light. The beads were washed and incubated with 1 ml of blocking buffer (PBS, 1% (w/v) BSA, 0.02% (w/v) Tween-20) in a rotator for 1 hr RT protected from light. Finally, the beads were counted with a hemacytometer, resuspended in blocking buffer at 2×10^6 beads/ml, and stored protected from light at 4 °C until ready for use.

Testing of Covalent Coupled IGF-R1 Capture Antibodies to Luminex Beads

[0074] The presence of capture antibody on the bead surface was confirmed using surface testing. 50 μ l of assay buffer (PBS, 1% (w/v) BSA, 0.05% (w/v) Tween 20, 0.05% (w/v) azide) containing 2500 beads were added to Millipore filter bottom plate wells (Bedford, MA). The beads were washed by placing the plate over a Millipore vacuum manifold (Bedford, MA) to remove the liquid and the beads were resuspended in 100 μ l/well of PBST wash buffer. Finally, the wash buffer was removed from the wells via vacuum and the beads were incubated with 100 μ l/well of PE-GAM diluted 1/100 in assay buffer. The plate was incubated on a 96-well plate shaker (Lab Line Instruments, Melrose Park, IL) at

EP 2 534 490 B1

300 rpm for 30 min RT protected from light. The beads were subsequently washed 3 times via vacuum filtration using 100 μ l/well of wash buffer and resuspended in 100 μ l/well of assay buffer. The MFI of at least 50 beads/well was measured using a Luminex¹⁰⁰ instrument obtained from Bio-Rad Laboratories (Hercules, CA) running Bioplex manager 4.1.1 software. An MFI of at least 20,000 was used to confirm the presence of usable quantities of antibody on the bead surface.

Covalent Coupling of Intra-assay IGF-R1 Peptide Standards to Luminex Beads

[0075] IGF1R [PYPY1162/1163] reference standard peptides were prepared by reconstituting the lyophilized peptide in 2.5 ml PBS to give a final concentration of 10mg/ml. Initial 10 fold dilution with subsequent 10-fold were made using diluent buffer (PBS, 1% (w/v) BSA, 0.02% (w/v) Tween-20). The phospho-IGF1R peptide was covalently coupled to the surface of four different sets of carboxylated beads at four different concentrations using a two-step carbodimide procedure. The bead sets were washed by centrifuging 1.25×10^7 beads for 5 min at $14000 \times g$ 4 °C in an Eppendorf 5415D centrifuge (Westbury, NY). The supernatant was carefully removed and 800 μ l of 0.1M sodium phosphate buffer pH 4.8 (activation buffer) was added. The beads were then vortexed for 15 seconds and sonicated for 15 seconds using a SPER SCIENTIFIC® LTD Ultrasonic Cleaner (Scottsdale, AZ). The beads were washed an additional time with activation buffer, and resuspended 200 μ l of freshly prepared 5 mg/ml EDC prepared in activation buffer. The beads were incubated in a rotator for 20 min RT protected from light. At the end of the EDC step, each beads were washed and resuspended with individual concentration of 1000, 100, 10 and 1 ng/ml of phospho-IGF1R peptide made from a 10-fold serial dilutions of 10mg/ml prepared in PBS. The beads were then incubated for 1hr RT in a rotator protected from light. The beads were washed and incubated with 1 ml of blocking buffer (PBS, 1% (w/v) BSA, 0.02% (w/v) Tween-20) in a rotator for 1 hr RT protected from light. Finally, the beads were counted with a hemacytometer, resuspended in blocking buffer at 2×10^6 beads/ml, and stored protected from light at 4 °C until ready for use.

Testing of IGF-R1 Peptide Coupled Luminex Beads

[0076] The presence of phospho-IGF1R peptide on the bead surface was confirmed using surface testing. 50 μ l of assay buffer (PBS, 1% (w/v) BSA, 0.05% (w/v) Tween 20, 0.05% (w/v) azide) containing 2500 beads were added to Millipore filter bottom plate wells (Bedford, MA). The beads were washed by placing the plate over a Millipore vacuum manifold (Bedford, MA) to remove the liquid and the beads were resuspended in 100 μ l/well of PBST wash buffer. Finally, the wash buffer was removed from the wells via vacuum and the beads were incubated with 100 μ l/well of rabbit anti-phospho-IGF-R1 antibody diluted in assay buffer. The plate was incubated on a 96-well plate shaker (Lab Line Instruments, Melrose Park, IL) at 300 rpm for 30 min RT protected from light. Following the incubation step, the beads were washed 4 times, resuspended in 50 μ l/well of 1 μ g/ml of phycoerthrin labeled goat anti-rabbit IgG conjugate, and incubated on a plate shaker for 20 min at RT protected from light. The beads were subsequently washed 3 times via vacuum filtration using 100 μ l/well of wash buffer and resuspended in 100 μ l/well of assay buffer. The MFI of at least 50 beads/well was measured using a Luminex¹⁰⁰ instrument obtained from Bio-Rad Laboratories (Hercules, CA) running Bioplex manager 4.1.1 software. phospho-IGF1R peptide,

IGF-R1 Intra-assay Analysis of Biological Samples

[0077] Sample analysis using the Luminex based assay was performed by adding 50 μ l of a 50,000 beads/ml of capture antibody suspension prepared in assay buffer to each well of a pre-wet filter bottom 96-well plate. The beads were washed with 100 μ l/well of assay buffer via vacuum filtration. The capture beads were resuspended in 50 μ l of diluted samples, or quality control samples (QC) in duplicate wells and incubated on a plate shaker for 1 hr at RT protected from light. The beads were washed 4 times, resuspended in 50 μ l of a 50,000 beads/ml of the four different bead sets of peptide mentioned in section 2.2.3. The beads were filtered, resuspended in 50 μ l/well of 1.0 μ g/ml anti-phospho IGF1R reporter antibody, and incubated on a plate shaker for 0.5 hrs at RT protected from light. Following the incubation step, the beads were washed 4 times, resuspended in 50 μ l/well of 1 μ g/ml of PE-Goat anti rabbit IgG, and incubated on a plate shaker for 20 min at RT protected from light. Finally, the beads were washed 4 times and resuspended in 100 μ l/well of assay buffer. The MFI of at least 50 beads per well was measured using a Bioplex Luminex instrument running Bioplex manager 4.1 software (Bio-Rad Laboratories, Hercules, CA). The standard curve generated from the phospho-IGF-R1 intra-standard curve is shown in Figure 6A. The phospho-IGF1R concentration in each of the PBMC lysate samples using the intra-assay 4-parameter logistic curve fit is shown in Figure 6B.

EXAMPLE 5 - CHARACTERIZATION OF A β PEPTIDES

Peptides

5 **[0078]** All peptides were received as lyophilized powder. Modified peptides were obtained from GenScript (GS) and Anaspec (AN). These peptides were synthesized using solid phase methods known to those skilled in the art (See, for example, Barany, G. et al., *The Peptides: Analysis, Synthesis, Biology - Special Methods in Peptide Synthesis, Part A*, Vol. 2, pp. 3-284, Gross, E. et al., eds., Academic Press, New York, publ. (1980); and in Stewart, J.M. et al., *Solid-Phase Peptide Synthesis*, 2nd Edition, Pierce Chemical Co., Rockford, IL, publ. (1984)).

10 **[0079]** GS 1-6 and AN7 peptides were received and reconstituted in ddH₂O to a concentration of 1mg/ml. These were then aliquoted out into 100 μ l aliquots in the 1.4 ml blank tubes PP, round Matrix (Thermo Scientific, cat#4249, lot 1030509). The full length A β ₄₂ peptide was purchase from MSD (lot # T03080X1). This peptide was diluted in DMSO to make a solution of 0.1mg/ml. This was then aliquoted out in 100 μ l aliquots in the 1.4 ml blank tubes. These peptides were kept frozen at -70 °C for storage. Figure 13 shows the structures of the polyethylene glycol spacers incorporated into the modified A β ₍₁₋₄₂₎ peptides.

TABLE 5: List of A β Peptides

GS#	Peptide Sequence	% Purity (HPLC)	MW
GS 1	DAEFRHDSGYEVHHQK- $\{$ PEG(20-atoms) $\}$ 3-GGVVIA (SEQ ID NO:12)	95	3406.71
GS 2	DAEFRHDSGYEVHHQK- $\{$ PEG(9-atoms) $\}$ 6-MVGGVVIA (SEQ ID NO:13)	95	3553.02
GS 3	DAEFRHDSGYEVHHQK-PEG(9-ATOMS)5-IGLMVGGVVIA (SEQ ID NO:14)	95	3691.15
GS 4	DAEFRHDSGYEVHHQKEERPIGLMVGGVVIA (SEQ ID NO:6)	96	3476.91
GS 5	DAEFRHDSGYEVHHQKDREPNRIGLMVGGVVIA (SEQ ID NO:8)	97	3733.17
GS 6	DAEFRHDSGYEVHHQKIGLMVGGVVIA (SEQ ID NO:4)	98	2965.37
AN 7	DAEFRHDSGYEVHVMVGGVVIA (SEQ ID NO:2)	90	2288.49
FL	DAEFRHDSGYEVHHQKLVFFAEDVGSNKGAIIGLMVGGVVIADAEFRHDSGYEVHVMVGGVVIA (SEQ ID NO:19)		

Dynamic Light Scattering

45 **[0080]** The novel peptides (GenScript) were received as dry powders, and two sets of stock samples were prepared by weighing small amounts (~0.5 mg each) in 1.8 ml polypropylene tubes and dissolving in a simple phosphate buffer (10 mM Na₂HPO₄, pH 7.4, 10 mM NaCl, prepared in 99.9% D₂O; filtered through 0.2 μ m filter). One set was prepared at 1.0 mg/ml, the second set was prepared at 0.10 mg/ml, and stored at room temperature. Peptides were dissolved by vortexing for 1 min, and centrifuged in a microcentrifuge for 5 min at 14,000 rpm, at room temperature. For A β ₄₂ samples (MSD), vials containing 0.1 mg peptide were suspended in 1.0 ml buffer, and treated as above. A volume (200 μ l) of each centrifuged 1.0 mg/ml stock was transferred to a 0.5 ml polypropylene tube, and provided for NMR analysis.

50 **[0081]** The absorbance spectra of all samples were recorded (220-750 nm) using a NANODROP®ND-1000 instrument, and blanked against the buffer. Dynamic light scattering analysis was conducted on the peptides in a 384 well polystyrene plate (CORNING®, type 3540) with a Wyatt DLS DynaPro plate reader. Data collection and analysis was completed using software from the manufacturer (DYNAMICS, versions 7.0.0.94 and 7.0.1.12). Each peptide was evaluated in triplicate with 30 μ l loaded per well, and overlaid with 5 μ l mineral oil, to minimize evaporation. Buffer blanks were also included in the analysis for comparison. After loading the plate, a transparent adhesive sealing tape cover was applied to the plate and the plate was centrifuged for 2 min at 1000 rpm. Each sample on the plate was read 30 times, 5 sec per acquisition, maintaining a temperature of 25 °C. Data sets were collected on both the 1.0 mg/ml and 0.10 mg/ml

EP 2 534 490 B1

samples over the course of 27 days. The adhesive cover was removed to read the samples in the plate reader, and used to cover the plate between readings over the 27 day time course.

[0082] Figures 7A through 7F show dynamic light scattering data. In Figure 7, the full length A β ₄₂ peptide was subjected to DLS analysis and compared to four representative modified peptides. The full length peptide was shown to be aggregated with results that calculated the radius of the different aggregate species to be between 82 and 231nm in length. This adds up to large molecular weight aggregates in the solution. However, the modified peptides remain monomeric as determined by both molecular weights as well as radius. GS#3 was contrasted with the other peptides because it did retain some aggregation (Figure 7E). These results demonstrate that the modified peptides which are lacking an aggregation domain, do in fact remain monomeric in solution. Figure 7a represents the raw data accumulated for all five peptides. Shown is the intensity autocorrelation versus time. The higher the intensity autocorrelation number is represents larger diameters of the peptides in solution. Figures 7b-7f depict the percent mass versus the radius of the peptides. Monomeric peptides would be represented by a larger percent mass at the smaller radius size. The larger aggregated peptides have smaller percent masses at a higher radius size.

TABLE 6: Summary of DLS data

	Item	Radius (nm)	%Pd	Mw-R (kDa)	%Intensity	% Mass
GS#1	Peak1	1.2	4.6	5.0	6.3	99.9
	Peak 2	48.4	3.9	29512.0	93.7	0.1
GS#2	Peak 1	0.9	4.3	3.0	1.6	98.0
	Peak 2	4.6	1.9	117.0	3.4	1.8
	Peak 3	36.9	3.8	15580.0	76.1	0.1
	Peak 4	172.0	4.5	572266.0	18.9	0.1
GS#3	Peak 1	4.5	0.0	119.0	0.4	57.9
	Peak 2	15.7	4.5	2101.0	4.8	19.7
	Peak 3	61.6	4.5	51794.0	94.8	22.4
GS#4	Peak 1	1.3	3.2	6.0	3.8	97.7
	Peak 2	6.0	0.0	225.0	0.6	0.2
	Peak 3	27.0	4.5	7527.0	5.2	0.0
	Peak 4	127.0	4.3	283287.0	25.1	0.2
FLA β 1-42	Peak 1	82.9	4.4	103812.0	50.4	26.1
	Peak 2	231.0	3.2	1149570.0	49.6	73.9

Circular Dichroism

[0083] Circular dichroism (CD) spectra were collected using an Aviv Model 202 Circular dichroism spectrometer. Samples were pipetted in 1 mm path length quartz cuvettes, and scanned from 260-185 nm. Parameters for collecting data include spectral bandwidth of 1.00 nm, a step size of 1.0 nm, an averaging time of 20 sec per point, and temperature set at 25 °C. Samples were stored in the quartz cuvettes at room temperature, and scanned over a time course of 23 days. Raw data was corrected for blank buffer contributions, and presented in the format of mdeg versus wavelength.

[0084] Figure 8 shows the circular dichroism analysis. Circular dichroism analysis was performed on the full length A β ₄₂ and four representative peptides to determine the order and secondary structures of these peptides. As shown in Figure 8, the full length peptide shows more of an ordered structure than the other peptides. The four representative peptides contain an unordered CD spectra when compared to the full length peptide. These data suggest that the modified peptides do not aggregate or form any higher order structures unlike that of the full length peptide.

MSD ELISA

[0085] Biotin labeled anti-C-terminal A β ₄₂ antibody (565-20 μ g/ml) was immobilized to a 96 well MSD streptavidin coated plate by adding 30 μ l/well. The plate was then covered and incubated overnight at 25 °C, shaking at 500rpm. The plates were then washed 3x with 300 μ l/well of wash buffer (R & D system cat# WA126). After washing, 225 μ l/well

EP 2 534 490 B1

of blocking buffer (1%BSA + 0.1% Tween-20 in PBS) was added to the plate and incubated for 30 minutes at room temperature, shaking at 500 rpm. Once the blocking step was done, the plates were washed as described previously. Reference standard A β ₄₂ peptides (full length or modified peptides) were added to the wells. A β ₄₂ peptides were captured by the immobilized capture antibody. A second ruthenium tagged (Ru) antibody to the N-terminus of A β ₄₂ (26D6) was added thereby completing the sandwich. The complex was detected using an MSD sector 6000 instrument using ECL. The raw fluorescence units (RFU) measured by the instrument were fit to a 4-parameter logistic model to create a standard curve.

[0086] Figure 9 shows peptide stability data. The full length A β ₄₂ and seven modified peptides were subjected to stability studies at different temperatures for up to 40 days (Figures 9A-9F). These peptides were kept at 4 °C, 25 °C, and 37 °C for the specified length of time and then frozen until the assay was run. Peptides were then collected and run on an MSD Elisa format. Results are shown as a percent of the baseline signal for each peptide measured at time zero. Indeed, short term incubation at 37 °C has been used to estimate the long term stability of molecules at 4 °C and room temperature (Anderson et al., Clinical Chemistry, 37(3): 398-402 (1991)). Therefore, incubation of the peptides at 37 °C for short term analysis can be used to assess the long term stability of the peptides. As shown in Figure 9, the full length A β ₄₂ peptide signal drops dramatically starting at 16 hr incubation at 37 °C. In contrast, the modified peptides remain stable at all temperatures measured. This data would suggest that these modified peptides are more stable than the full length A β ₄₂.

[0087] Figures 10A-10I show the full length A β ₄₂ and seven modified peptides were subjected to stability studies at different temperatures for up to 60 days. These peptides were kept at 25 °C and 37 °C for the specified length of time and then frozen until the assay was run. Peptides were then collected and run on an MSD Elisa format. Results are shown as a standard curve, plotting signal versus peptide concentration. As shown in Figure 10, the full length peptide gave decreasing standard curves at 25 °C and 37 °C. In comparison, all seven peptides analyzed gave similar curves across all time points and temperature ranges (only 37 °C shown). The results suggest that the modified peptides will give a more consistent signal than the full length A β ₄₂ peptide when used as a standard for assay reproducibility.

[0088] Figure 11 shows the standard curve analysis of full length versus modified peptides. Full length A β ₄₂ and seven modified peptides were diluted out for an eight point calibration curve and ran on the MSD Elisa format. As shown in Figure 11, all of the peptides produced almost identical standard curves. This result suggests that the modified peptides can be used in the place of the full length peptide for the calculation of A β in sample matrixes.

[0089] Figure 12 shows a CSF sample analysis using full length versus modified peptides. Full length A β ₄₂ and seven modified peptides were diluted out for an eight point calibration curve and ran on the MSD Elisa format with 13 CSF samples. The concentration of A β in each CSF sample was calculated based on the standard curve for each peptide. As shown in Figure 12, the back calculated A β concentrations in the CSF samples were equivalent and was independent of which A β peptide used for the standard curve. This suggests that these modified peptides can be used in place of the full length A β ₄₂ peptide in these assays without affecting the calculations of the A β levels.

SEQUENCE LISTING

[0090]

<110> Bristol-Myers Squibb Company
Rhyne, Paul

<120> IMMUNOASSAY STANDARDS AND MEASUREMENT OF CLINICAL BIOMARKERS USING INTRA-ASSAY CALIBRATION STANDARDS

<130> 11513 PCT

<150> 61/302835

<151> 2010-02-09

<160> 27

<170> PatentIn version 3.5

<210> 1

<211> 42

<212> PRT

<213> Artificial Sequence

EP 2 534 490 B1

<220>

<223> Peptide

<400> 1

5

Asp Ala Glu Phe Arg His Asp Ser Gly Tyr Glu Val His His Gln Lys
1 5 10 15

10

Leu Val Phe Phe Ala Glu Asp Val Gly Ser Asn Lys Gly Ala Ile Ile
20 25 30

15

Gly Leu Met Val Gly Gly Val Val Ile Ala
35 40

<210> 2

<211> 21

<212> PRT

20

<213> Artificial Sequence

<220>

<223> Modified Peptide

25

<400> 2

Asp Ala Glu Phe Arg His Asp Ser Gly Tyr Glu Val His Met Val Gly
1 5 10 15

30

Gly Val Val Ile Ala
20

<210> 3

35

<211> 22

<212> PRT

<213> Artificial Sequence

<220>

40

<223> Modified Peptide

<400> 3

45

Asp Ala Glu Phe Arg His Asp Ser Gly Tyr Glu Val His His Gln Lys
1 5 10 15

50

Gly Gly Val Val Ile Ala
20

<210> 4

<211> 27

<212> PRT

<213> Artificial Sequence

55

<220>

<223> Modified Peptide

EP 2 534 490 B1

<400> 4

5 Asp Ala Glu Phe Arg His Asp Ser Gly Tyr Glu Val His His Gln Lys
1 5 10 15

Ile Gly Leu Met Val Gly Gly Val Val Ile Ala
20 25

10 <210> 5
<211> 26
<212> PRT
<213> Artificial Sequence

15 <220>
<223> Modified Peptide

<400> 5

20 Asp Ala Glu Phe Arg His Asp Ser Gly Tyr Glu Val His His Gln Lys
1 5 10 15

25 Glu Glu Arg Pro Gly Gly Val Val Ile Ala
20 25

30 <210> 6
<211> 31
<212> PRT
<213> Artificial Sequence

<220>
<223> Modified Peptide

35 <400> 6

Asp Ala Glu Phe Arg His Asp Ser Gly Tyr Glu Val His His Gln Lys
1 5 10 15

40 Glu Glu Arg Pro Ile Gly Leu Met Val Gly Gly Val Val Ile Ala
20 25 30

45 <210> 7
<211> 28
<212> PRT
<213> Artificial Sequence

50 <220>
<223> Modified Peptide

<400> 7

55

EP 2 534 490 B1

Asp Ala Glu Phe Arg His Asp Ser Gly Tyr Glu Val His His Gln Lys
 1 5 10 15

5 Asp Arg Glu Glu Arg Pro Gly Gly Val Val Ile Ala
 20 25

<210> 8
 <211> 33
 10 <212> PRT
 <213> Artificial Sequence

<220>
 <223> Modified Peptide

15 <400> 8

Asp Ala Glu Phe Arg His Asp Ser Gly Tyr Glu Val His His Gln Lys
 1 5 10 15

20 Asp Arg Glu Pro Asn Arg Ile Gly Leu Met Val Gly Gly Val Val Ile
 20 25 30

25 Ala

<210> 9
 <211> 23
 30 <212> PRT
 <213> Artificial Sequence

<220>
 <223> Modified Peptide

35 <220>
 <221> MISC_FEATURE
 <222> (17)..(36)
 <223> Xaa represents up to 20 Lys residues located between Lys at position 16 and Gly at position 18

40 <400> 9

Asp Ala Glu Phe Arg His Asp Ser Gly Tyr Glu Val His His Gln Lys
 1 5 10 15

45 Xaa Gly Gly Val Val Ile Ala
 20

50 <210> 10
 <211> 23
 <212> PRT
 <213> Artificial Sequence

55 <220>
 <223> Modified Peptide

<220>

EP 2 534 490 B1

<221> MISC_FEATURE

<222> (17)..(36)

<223> Xaa represents up to 20 Glu acid residues located between Lys at position 16 and Gly at position 18

5 <400> 10

Asp Ala Glu Phe Arg His Asp Ser Gly Tyr Glu Val His His Gln Lys
1 5 10 15

10 Xaa Gly Gly Val Val Ile Ala
20

<210> 11

15 <211> 23

<212> PRT

<213> Artificial Sequence

<220>

20 <223> Modified Peptide

<220>

<221> MISC_FEATURE

<222> (17)..(36)

25 <223> Xaa represents up to 20 Ala residues located between Lys at position 16 and Gly at position 18

<400> 11

30 Asp Ala Glu Phe Arg His Asp Ser Gly Tyr Glu Val His His Gln Lys
1 5 10 15

Xaa Gly Gly Val Val Ile Ala
20

35 <210> 12
<211> 22

<212> PRT

<213> Artificial Sequence

40 <220>

<223> Modified Peptide

<220>

45 <221> MISC_FEATURE

<222> (17)..(36)

<223> Sequence comprises a PEG(20-ATOMS)3 linker located between Lys located at position 16 and the Gly located at position 17

50 <400> 12

Asp Ala Glu Phe Arg His Asp Ser Gly Tyr Glu Val His His Gln Lys
1 5 10 15

55 Gly Gly Val Val Ile Ala
20

EP 2 534 490 B1

<210> 13
<211> 24
<212> PRT
<213> Artificial Sequence
5
<220>
<223> Modified Peptide

<220>
10 <221> MISC_FEATURE
<222> (17)..(34)
<223> Sequence comprises a PEG(9-ATOMS)6 linker located between Lys at position 16 and Met at position 17

<400> 13
15
Asp Ala Glu Phe Arg His Asp Ser Gly Tyr Glu Val His His Gln Lys
1 5 10 15

20 Met Val Gly Gly Val Val Ile Ala
20

<210> 14
<211> 27
25 <212> PRT
<213> Artificial Sequence

<220>
<223> Modified Peptide
30

<220>
<221> MISC_FEATURE
<222> (17)..(31)
<223> Sequence comprises a PEG(9-ATOMS)5 linker located between Lys at position 16 and Ile at position 17
35

<400> 14

Asp Ala Glu Phe Arg His Asp Ser Gly Tyr Glu Val His His Gln Lys
40 1 5 10 15

Ile Gly Leu Met Val Gly Gly Val Val Ile Ala
20 25

45 <210> 15
<211> 40
<212> PRT
<213> Artificial Sequence

50 <220>
<223> Modified Peptide

<400> 15
55

EP 2 534 490 B1

Asp Ala Glu Phe Arg His Asp Ser Gly Tyr Glu Val His His Gln Lys
 1 5 10 15

5 Leu Val Phe Phe Ala Glu Asp Val Gly Ser Asn Lys Gly Ala Ile Ile
 20 25 30

10 Gly Leu Met Val Gly Gly Val Val
 35 40

<210> 16

<211> 6

<212> PRT

15 <213> Artificial Sequence

<220>

<223> Modified Peptide

20 <400> 16

Asp Arg Glu Pro Asn Arg
 1 5

25 <210> 17

<211> 38

<212> PRT

<213> Artificial Sequence

30 <220>

<223> Modified Peptide

<400> 17

35 Asp Ala Glu Phe Arg His Asp Ser Gly Tyr Glu Val His His Gln Lys
 1 5 10 15

40 Leu Val Phe Phe Ala Glu Asp Val Gly Ser Asn Lys Gly Ala Ile Ile
 20 25 30

Gly Leu Met Val Gly Gly
 35

45 <210> 18

<211> 5

<212> PRT

<213> Artificial Sequence

50 <220>

<223> Modified Peptide

<400> 18

55 Lys Leu Val Phe Phe
 1 5

EP 2 534 490 B1

<210> 19
<211> 63
<212> PRT
<213> Artificial Sequence

5

<220>
<223> Modified Peptide

10

Asp Ala Glu Phe Arg His Asp Ser Gly Tyr Glu Val His His Gln Lys
1 5 10 15

15

Leu Val Phe Phe Ala Glu Asp Val Gly Ser Asn Lys Gly Ala Ile Ile
20 25 30

20

Gly Leu Met Val Gly Gly Val Val Ile Ala Asp Ala Glu Phe Arg His
35 40 45

25

Asp Ser Gly Tyr Glu Val His Met Val Gly Gly Val Val Ile Ala
50 55 60

<210> 20
<211> 441
<212> PRT
<213> Artificial Sequence

30

<220>
<223> Modified Peptide

35

<400> 20

40

45

50

55

EP 2 534 490 B1

	Met	Ala	Glu	Pro	Arg	Gln	Glu	Phe	Glu	Val	Met	Glu	Asp	His	Ala	Gly
	1				5					10					15	
5	Thr	Tyr	Gly	Leu	Gly	Asp	Arg	Lys	Asp	Gln	Gly	Gly	Tyr	Thr	Met	His
				20					25					30		
10	Gln	Asp	Gln	Glu	Gly	Asp	Thr	Asp	Ala	Gly	Leu	Lys	Glu	Ser	Pro	Leu
			35					40					45			
15	Gln	Thr	Pro	Thr	Glu	Asp	Gly	Ser	Glu	Glu	Pro	Gly	Ser	Glu	Thr	Ser
		50					55					60				
20	Asp	Ala	Lys	Ser	Thr	Pro	Thr	Ala	Glu	Asp	Val	Thr	Ala	Pro	Leu	Val
	65					70					75					80
25	Asp	Glu	Gly	Ala	Pro	Gly	Lys	Gln	Ala	Ala	Ala	Gln	Pro	His	Thr	Glu
					85					90					95	
30	Ile	Pro	Glu	Gly	Thr	Thr	Ala	Glu	Glu	Ala	Gly	Ile	Gly	Asp	Thr	Pro
				100					105					110		
35																
40																
45																
50																
55																

EP 2 534 490 B1

Ser Leu Glu Asp Glu Ala Ala Gly His Val Thr Gln Ala Arg Met Val
 115 120 125

5
 Ser Lys Ser Lys Asp Gly Thr Gly Ser Asp Asp Lys Lys Ala Lys Gly
 130 135 140

10
 Ala Asp Gly Lys Thr Lys Ile Ala Thr Pro Arg Gly Ala Ala Pro Pro
 145 150 155 160

15
 Gly Gln Lys Gly Gln Ala Asn Ala Thr Arg Ile Pro Ala Lys Thr Pro
 165 170 175

20
 Pro Ala Pro Lys Thr Pro Pro Ser Ser Gly Glu Pro Pro Lys Ser Gly
 180 185 190

25
 Asp Arg Ser Gly Tyr Ser Ser Pro Gly Ser Pro Gly Thr Pro Gly Ser
 195 200 205

30
 Arg Ser Arg Thr Pro Ser Leu Pro Thr Pro Pro Thr Arg Glu Pro Lys
 210 215 220

35
 Lys Val Ala Val Val Arg Thr Pro Pro Lys Ser Pro Ser Ser Ala Lys
 225 230 235 240

40
 Ser Arg Leu Gln Thr Ala Pro Val Pro Met Pro Asp Leu Lys Asn Val
 245 250 255

45
 Lys Ser Lys Ile Gly Ser Thr Glu Asn Leu Lys His Gln Pro Gly Gly
 260 265 270

50
 Gly Lys Val Gln Ile Ile Asn Lys Lys Leu Asp Leu Ser Asn Val Gln
 275 280 285

55
 Ser Lys Cys Gly Ser Lys Asp Asn Ile Lys His Val Pro Gly Gly Gly
 290 295 300

60
 Ser Val Gln Ile Val Tyr Lys Pro Val Asp Leu Ser Lys Val Thr Ser
 305 310 315 320

65
 Lys Cys Gly Ser Leu Gly Asn Ile His His Lys Pro Gly Gly Gly Gln
 325 330 335

70
 Val Glu Val Lys Ser Glu Lys Leu Asp Phe Lys Asp Arg Val Gln Ser
 340 345 350

75
 Lys Ile Gly Ser Leu Asp Asn Ile Thr His Val Pro Gly Gly Gly Asn
 355 360 365

80
 Lys Lys Ile Glu Thr His Lys Leu Thr Phe Arg Glu Asn Ala Lys Ala

EP 2 534 490 B1

	370		375		380												
5	Lys	Thr	Asp	His	Gly	Ala	Glu	Ile	Val	Tyr	Lys	Ser	Pro	Val	Val	Ser	
	385					390					395					400	
10	Gly	Asp	Thr	Ser	Pro	Arg	His	Leu	Ser	Asn	Val	Ser	Ser	Thr	Gly	Ser	
					405					410					415		
15	Ile	Asp	Met	Val	Asp	Ser	Pro	Gln	Leu	Ala	Thr	Leu	Ala	Asp	Glu	Val	
				420					425					430			
20	Ser	Ala	Ser	Leu	Ala	Lys	Gln	Gly	Leu								
			435					440									
	<210> 21																
	<211> 24																
	<212> PRT																
	<213> Artificial Sequence																
	<220>																
	<223> Modified Peptide																
25	<220>																
	<221> MISC_FEATURE																
	<222> (12)..(13)																
	<223> Sequence comprises a generic linker located between Leu at position 12 and Gly at position 13																
30	<400> 21																
35	Glu	Val	Met	Glu	Asp	His	Ala	Gly	Thr	Tyr	Gly	Leu	Gly	Ala	Ala	Pro	
	1			5						10					15		
40	Pro	Gly	Gln	Lys	Gly	Gln	Ala	Asn									
				20													
	<210> 22																
	<211> 22																
	<212> PRT																
	<213> Artificial Sequence																
45	<220>																
	<223> Modified Peptide																
	<220>																
	<221> MISC_FEATURE																
50	<222> (12)..(13)																
	<223> Sequence comprises a generic linker located between Leu at position 12 and Ser at position 13																
	<400> 22																
55	Glu	Val	Met	Glu	Asp	His	Ala	Gly	Thr	Tyr	Gly	Leu	Ser	Gly	Asp	Arg	
	1			5						10					15		

EP 2 534 490 B1

Ser Gly Tyr Ser Ser Pro
20

5 <210> 23
<211> 32
<212> PRT
<213> Artificial Sequence

10 <220>
<223> Modified Peptide

15 <220>
<221> MISC_FEATURE
<222> (12)..(13)
<223> Sequence comprises a generic linker located between Asn at position 12 and Ile at position 13

20 <220>
<221> MISC_FEATURE
<222> (23)..(23)
<223> Sequence comprises a phosphate at Thr at position 23

<400> 23

25 Gly Ala Ala Pro Pro Gly Gln Lys Gly Gln Ala Asn Ile Pro Ala Lys
1 5 10 15

30 Thr Pro Pro Ala Pro Lys Thr Pro Pro Ser Ser Gly Glu Pro Pro Lys
20 25 30

35 <210> 24
<211> 32
<212> PRT
<213> Artificial Sequence

40 <220>
<223> Modified Peptide

45 <220>
<221> MISC_FEATURE
<222> (12)..(13)
<223> Sequence comprise a generic linker located between Asn at position 12 and Arg at position 13

50 <220>
<221> MISC_FEATURE
<222> (23)..(23)
<223> A phosphate at Thr at position 23

<400> 24

55 Gly Ala Ala Pro Pro Gly Gln Lys Gly Gln Ala Asn Arg Glu Pro Lys
1 5 10 15

Lys Val Ala Val Val Arg Thr Pro Pro Lys Ser Pro Ser Ser Ala Lys
20 25 30

<210> 25

EP 2 534 490 B1

<211> 22
 <212> PRT
 <213> Artificial Sequence

5 <220>
 <223> Modified Peptide

<220>
 <221> MISC_FEATURE
 10 <222> (12)..(13)
 <223> Sequence comprises a generic linker located between Asn at position 12 and Ser at position 13

<400> 25

15 Gly Ala Ala Pro Pro Gly Gln Lys Gly Gln Ala Asn Ser Gly Asp Arg
 1 5 10 15

Ser Gly Tyr Ser Ser Pro
 20 20

<210> 26
 <211> 30
 <212> PRT
 25 <213> Artificial Sequence

<220>
 <223> Modified Peptide

30 <220>
 <221> MISC_FEATURE
 <222> (12)..(13)
 <223> A phosphate at Thr at position 11

35 <220>
 <221> MISC_FEATURE
 <222> (21)..(22)
 <223> Sequence comprises a generic linker located between Lys at position 21 and Ser at position 22

40 <400> 26

Ile Pro Ala Lys Thr Pro Pro Ala Pro Lys Thr Pro Pro Ser Ser Gly
 1 5 10 15

45 Glu Pro Pro Lys Ser Gly Asp Arg Ser Gly Tyr Ser Ser Pro
 20 25 30

<210> 27
 50 <211> 30
 <212> PRT
 <213> Artificial Sequence

<220>
 55 <223> Modified peptide

<220>
 <221> MISC_FEATURE

EP 2 534 490 B1

<222> (10)..(11)

<223> Sequence comprises a generic linker between Pro at position 10 and Arg at position 11

<220>

5 <221> MISC_FEATURE

<222> (21)..(22)

<223> A phosphate at Thr at position 21

<400> 27

10

Ser Gly Asp Arg Ser Gly Tyr Ser Ser Pro Arg Glu Pro Lys Lys Val
1 5 10 15

15

Ala Val Val Arg Thr Pro Pro Lys Ser Pro Ser Ser Ala Lys
20 25 30

Claims

20

1. A modified A β ₄₂ peptide comprising the N-terminal immunoreactive domain and the C-terminal immunoreactive domain of A β ₄₂, wherein the central aggregation domain amino acids 17-20 and various lengths of the adjacent C-terminal peptide are replaced with a linker selected from:

25

- a linker having the amino acid sequence EERP or DREPNR,
- linkers consisting of an integer number of lysine residues or an integer number of glutamic acid residues or an integer number of alanine residues,
- polyethylene glycols (PEGs), and
- dendrimers and branched co-polymers able to couple amino acid residues.

30

2. The modified A β ₄₂ peptide of claim 1, wherein the linker has the amino acid sequence EERP or DREPNR.

3. The modified A β ₄₂ peptide of claim 2 having a sequence as set forth in any one of SEQ ID NOs: 5-8.

35

4. The modified A β ₄₂ peptide of claim 1, wherein the linker consists of an integer number of lysine residues or an integer number of glutamic acid residues or an integer number of alanine residues.

5. The modified A β ₄₂ peptide of claim 4 having a sequence as set forth in any one of SEQ ID NOs: 9-11.

40

6. The modified A β ₄₂ peptide of claim 1, wherein the linker is a polyethylene glycol (PEG).

7. The modified A β ₄₂ peptide of claim 6 having a sequence as set forth in any one of SEQ ID NOs: 12-14.

8. The modified A β ₄₂ peptide of claim 6 having a sequence as set forth in SEQ ID NOs: 14.

45

9. The modified A β ₄₂ peptide of claim 1, wherein the linker is selected from dendrimers and branched co-polymers able to couple amino acid residues.

10. The modified A β ₄₂ peptide according to any one of claims 1-9 comprising the epitope recognized by an A β ₄₂ N-terminal specific antibody.

50

11. The modified A β ₄₂ peptide according to any one of claims 1-10 comprising the epitope recognized by an A β ₄₂ C-terminal specific antibody.

55

12. Use of a modified A β ₄₂ peptide according to any one of claims 1-11 as a reference standard in an immunoassay.

13. The use of claim 12, wherein the immunoassay is selected from the group consisting of a sandwich immunoassay, a single antibody assay, a double sandwich immunoassay and a competition assay.

14. A method of measuring the quantity of an amyloid beta ($A\beta$) peptide analyte selected from $A\beta_{42}$, $A\beta_{40}$, and $A\beta_{38}$ in a biological sample, the method comprising:

- 5 (a) attaching a reference standard to at least two beads thereby forming a first bead set and a second bead set, wherein the reference standard comprises an epitope recognized by a first detection antibody and wherein each bead set comprises a different concentration of the reference standard;
- (b) attaching a capture antibody specific to the analyte to a third bead set;
- (c) mixing all of the bead sets together to form a suspension array;
- 10 (d) applying the biological sample to the suspension array whereby the analyte binds to the capture antibody on the third bead set;
- (e) adding a first detection antibody to the suspension array, wherein the first detection antibody binds the reference standard and analyte bound to the capture antibody;
- (f) measuring a first signal from the first detection antibody bound to the reference standard in the first bead set;
- 15 (g) measuring a second signal from the first detection antibody bound to the reference standard in the second bead set;
- (h) generating a standard curve based upon the first and second signals; and
- (i) quantitating the amount of the analyte in the third bead set by measuring a third signal from the first detection antibody and comparing the third signal to the first and second signal measurements on the standard curve;

20 wherein the reference standard comprises the modified $A\beta_{42}$ peptide according to any one of claims 1-11.

15. The method of claim 14, wherein the biological sample is selected from the group consisting of blood, serum, plasma, peripheral blood mononuclear cells, peripheral blood lymphocytes, tissue, cerebrospinal fluid and cells.

25 16. The method of claim 14, wherein the method is performed in a multi-well plate, nitrocellulose filter, glass fiber or on a glass slide.

17. The method of claim 14, wherein the first signal and second signal is a signal selected from the group consisting of phycoerythrin, alexa 532, streptavidin-phycoerythrin and streptavidin-Alexa 532.

30 18. A kit for conducting an immunoassay to detect $A\beta_{42}$ peptide, the kit comprising the modified $A\beta_{42}$ peptide according to any one of claims 1-11.

35 Patentansprüche

1. Modifiziertes $A\beta_{42}$ -Peptid, umfassend die N-terminale immunreaktive Domäne und die C-terminale immunreaktive Domäne von $A\beta_{42}$, wobei die Aminosäuren der zentralen Aggregationsdomäne 17-20 und verschiedene Längen des danebenliegenden C-terminalen Peptids durch einen Linker ersetzt sind, der ausgewählt ist unter:

- 40 - einem Linker mit der Aminosäuresequenz EERP oder DREP NR,
- Linkern bestehend aus einer ganzzahligen Anzahl von Lysinresten oder einer ganzzahligen Anzahl von Glutaminsäureresten oder einer ganzzahligen Anzahl von Alaninresten,
- Polyethylenglykolen (PEGs) und
- 45 - Dendrimeren und verzweigten Copolymeren, die Aminosäurereste verbinden können.

2. Modifiziertes $A\beta_{42}$ -Peptid nach Anspruch 1, wobei der Linker die Aminosäuresequenz EERP oder DREP NR aufweist.

3. Modifiziertes $A\beta_{42}$ -Peptid nach Anspruch 2, das eine Sequenz aufweist, wie sie in einer der SEQ ID NRn: 5-8 aufgeführt ist.

4. Modifiziertes $A\beta_{42}$ -Peptid nach Anspruch 1, wobei der Linker aus einer ganzzahligen Anzahl von Lysinresten oder einer ganzzahligen Anzahl von Glutaminsäureresten oder einer ganzzahligen Anzahl von Alaninresten besteht.

55 5. Modifiziertes $A\beta_{42}$ -Peptid nach Anspruch 4, das eine Sequenz aufweist, wie sie in einer der SEQ ID NRn: 9-11 aufgeführt ist.

6. Modifiziertes $A\beta_{42}$ -Peptid nach Anspruch 1, wobei der Linker ein Polyethylenglykol (PEG) ist.

EP 2 534 490 B1

7. Modifiziertes A β_{42} -Peptid nach Anspruch 6, das eine Sequenz aufweist, wie sie in einer der SEQ ID NRn: 12-14 aufgeföhrt ist.
- 5 8. Modifiziertes A β_{42} -Peptid nach Anspruch 6, das eine Sequenz aufweist, wie sie in SEQ ID NR: 14 aufgeföhrt ist.
9. Modifiziertes A β_{42} -Peptid nach Anspruch 1, wobei der Linker unter Dendrimeren und verzweigten Copolymeren, die Aminosäurereste verbinden können, ausgewählt ist.
10. Modifiziertes A β_{42} -Peptid nach einem der Ansprüche 1-9, umfassend das Epitop, welches durch einen für den A β_{42} -N-Terminus spezifischen Antikörper erkannt wird.
- 10 11. Modifiziertes A β_{42} -Peptid nach einem der Ansprüche 1-10, umfassend das Epitop, welches durch einen für den A β_{42} -C-Terminus spezifischen Antikörper erkannt wird.
12. Verwendung eines modifizierten A β_{42} -Peptids nach einem der Ansprüche 1-11 als Referenzstandard in einem Immunassay.
13. Verwendung nach Anspruch 12, wobei der Immunassay ausgewählt ist unter einem Sandwich-Immunassay, einem Einzelantikörperassay, einem Doppel-Sandwich-Immunassay und einem Wettbewerbsassay.
- 20 14. Verfahren zur Messung der Menge eines unter A β_{42} , A β_{40} und A β_{38} ausgewählten Amyloid-Beta-(A β -)Peptid-Analyten in einer biologischen Probe, wobei das Verfahren Folgendes umfasst:
- (a) Immobilisieren eines Referenzstandards auf mindestens zwei Beads zur Bildung eines ersten Bead-Sets und eines zweiten Bead-Sets, wobei der Referenzstandard ein Epitop umfasst, das von einem ersten Nachweisantikörper erkannt wird, und wobei jedes Bead-Set eine andere Konzentration des Referenzstandards umfasst;
- 25 (b) Immobilisieren eines für den Analyten spezifischen Capture-Antikörpers auf einem dritten Bead-Set;
- (c) Vermischen aller Bead-Sets zur Bildung eines Suspensionsarrays;
- 30 (d) Aufbringen der biologischen Probe auf das Suspensionsarray, wobei der Analyt an den Capture-Antikörper auf dem dritten Bead-Set bindet;
- (e) Hinzufügen eines ersten Nachweisantikörpers zum Suspensionsarray, wobei der erste Nachweisantikörper den Referenzstandard und am Capture-Antikörper gebundenen Analyten bindet;
- 35 (f) Messen eines ersten Signals vom ersten Nachweisantikörper, der an den Referenzstandard im ersten Bead-Set gebunden ist;
- (g) Messen eines zweiten Signals vom ersten Nachweisantikörper, der an den Referenzstandard im zweiten Bead-Set gebunden ist;
- (h) Erstellen einer Standardkurve auf der Grundlage der ersten und zweiten Signale und
- 40 (i) Quantifizieren der Menge an Analyt im dritten Bead-Set durch Messen eines dritten Signals vom ersten Nachweisantikörper und Vergleichen des dritten Signals mit den ersten und zweiten Signalmessungen auf der Standardkurve,
- wobei der Referenzstandard das modifizierte A β_{42} -Peptid nach einem der Ansprüche 1-11 umfasst.
- 45 15. Verfahren nach Anspruch 14, wobei die biologische Probe ausgewählt ist unter Blut, Serum, Plasma, peripheren mononukleären Blutzellen, Lymphozyten aus peripherem Blut, Gewebe, Liquor und Liquorzellen.
16. Verfahren nach Anspruch 14, wobei das Verfahren in einer Multiwell-Platte, einem Nitrozellulosefilter, einer Glasfaser oder auf einem Glass-Objektträger durchgeführt wird.
- 50 17. Verfahren nach Anspruch 14, wobei das erste Signal und das zweite Signal ein Signal ist, das ausgewählt ist unter Phycoerythrin, Alexa 532, Streptavidin-Phycoerythrin und Streptavidin-Alexa 532.
18. Kit zur Durchführung eines Immunassays zum Nachweis eines A β_{42} -Peptids, wobei das Kit das modifizierte A β_{42} -Peptid nach einem der Ansprüche 1-11 umfasst.
- 55

Revendications

- 5 1. Peptide A β_{42} modifié comprenant le domaine immunoréactif N-terminal et le domaine immunoréactif C-terminal de l'A β_{42} , dans lequel les acides aminés 17-20 du domaine d'agrégation central et diverses longueurs du peptide C-terminal adjacent sont remplacés par un segment de liaison sélectionné parmi :
 - un segment de liaison possédant la séquence d'acides aminés EERP ou DREPNR,
 - des segments de liaison consistant en un nombre entier de résidus lysine ou un nombre entier de résidus acide glutamique ou un nombre entier de résidus alanine,
 - 10 - des polyéthylènes glycols (PEG), et
 - des dendrimères et des copolymères ramifiés capables de coupler des résidus d'acides aminés.
- 15 2. Peptide A β_{42} modifié selon la revendication 1, dans lequel le segment de liaison possède la séquence d'acides aminés EERP ou DREPNR.
3. Peptide A β_{42} modifié selon la revendication 2 possédant une séquence telle que décrite dans l'une quelconque des SEQ ID NO: 5-8.
- 20 4. Peptide A β_{42} modifié selon la revendication 1, dans lequel le segment de liaison consiste en un nombre entier de résidus lysine ou un nombre entier de résidus acide glutamique ou un nombre entier de résidus alanine.
5. Peptide A β_{42} modifié selon la revendication 4 possédant une séquence telle que décrite dans l'une quelconque des SEQ ID NO: 9-11.
- 25 6. Peptide A β_{42} modifié selon la revendication 1, dans lequel le segment de liaison est un polyéthylène glycol (PEG).
7. Peptide A β_{42} modifié selon la revendication 6 possédant une séquence telle que décrite dans l'une quelconque des SEQ ID NO: 12-14.
- 30 8. Peptide A β_{42} modifié selon la revendication 6 possédant une séquence telle que décrite dans SEQ ID NO: 14.
9. Peptide A β_{42} modifié selon la revendication 1, dans lequel le segment de liaison est sélectionné parmi des dendrimères et des copolymères ramifiés capables de coupler des résidus d'acides aminés.
- 35 10. Peptide A β_{42} modifié selon l'une quelconque des revendications 1 à 9 comprenant l'épitope reconnu par un anticorps spécifique à l'extrémité N-terminale de l'A β_{42} .
- 40 11. Peptide A β_{42} modifié selon l'une quelconque des revendications 1 à 10 comprenant l'épitope reconnu par un anticorps spécifique à l'extrémité C-terminale de l'A β_{42} .
12. Utilisation d'un peptide A β_{42} modifié selon l'une quelconque des revendications 1 à 11 en tant qu'étalon de référence dans un dosage immunologique.
- 45 13. Utilisation selon la revendication 12, dans laquelle le dosage immunologique est sélectionné dans le groupe consistant en un dosage immunologique de type sandwich, un dosage d'anticorps individuel, un dosage immunologique de type double sandwich et un dosage par compétition.
- 50 14. Procédé de mesure de la quantité d'un analyte de peptide bêta-amyloïde (A β) sélectionné parmi l'A β_{42} , l'A β_{40} et l'A β_{38} dans un échantillon biologique, le procédé comprenant :
 - (a) l'attachement d'un étalon de référence à au moins deux billes en formant ainsi un premier ensemble de billes et un deuxième ensemble de billes, où l'étalon de référence comprend un épitope reconnu par un premier anticorps de détection et où chaque ensemble de billes comprend une concentration différente de l'étalon de référence ;
 - 55 (b) l'attachement d'un anticorps de capture spécifique à l'analyte à un troisième ensemble de billes ;
 - (c) le mélange de tous les ensembles de billes afin de former un réseau en suspension ;
 - (d) l'application de l'échantillon biologique au réseau en suspension, moyennant quoi l'analyte se lie à l'anticorps de capture sur le troisième ensemble de billes ;

EP 2 534 490 B1

(e) l'ajout d'un premier anticorps de détection au réseau en suspension, où le premier anticorps de détection se lie à l'étalon de référence et à l'analyte lié à l'anticorps de capture ;

(f) la mesure d'un premier signal à partir du premier anticorps de détection lié à l'étalon de référence dans le premier ensemble de billes ;

5 (g) la mesure d'un deuxième signal à partir du premier anticorps de détection lié à l'étalon de référence dans le deuxième ensemble de billes ;

(h) la génération d'une courbe d'étalonnage basée sur le premier et le deuxième signal ; et

10 (i) la quantification de la quantité d'analyte dans le troisième ensemble de billes en mesurant un troisième signal à partir du premier anticorps de détection et la comparaison du troisième signal avec les mesures du premier et du deuxième signal sur la courbe d'étalonnage ;

où l'étalon de référence comprend le peptide $A\beta_{42}$ modifié selon l'une quelconque des revendications 1 à 11.

15 **15.** Procédé selon la revendication 14, dans lequel l'échantillon biologique est sélectionné dans le groupe consistant en du sang, du sérum, du plasma, des cellules mononucléaires du sang périphérique, des lymphocytes du sang périphérique, un tissu, du liquide céphalo-rachidien et des cellules.

20 **16.** Procédé selon la revendication 14, où le procédé est réalisé dans une plaque multipuits, un filtre de nitrocellulose, une fibre de verre ou sur une lame en verre.

17. Procédé selon la revendication 14, dans lequel le premier et le deuxième signal est un signal sélectionné dans le groupe consistant en la phycoérythrine, l'Alexa 532, la streptavidine-phycoérythrine et la streptavidine-Alexa 532.

25 **18.** Kit pour réaliser un dosage immunologique afin de détecter un peptide $A\beta_{42}$, le kit comprenant le peptide $A\beta_{42}$ modifié selon l'une quelconque des revendications 1 à 11.

30

35

40

45

50

55

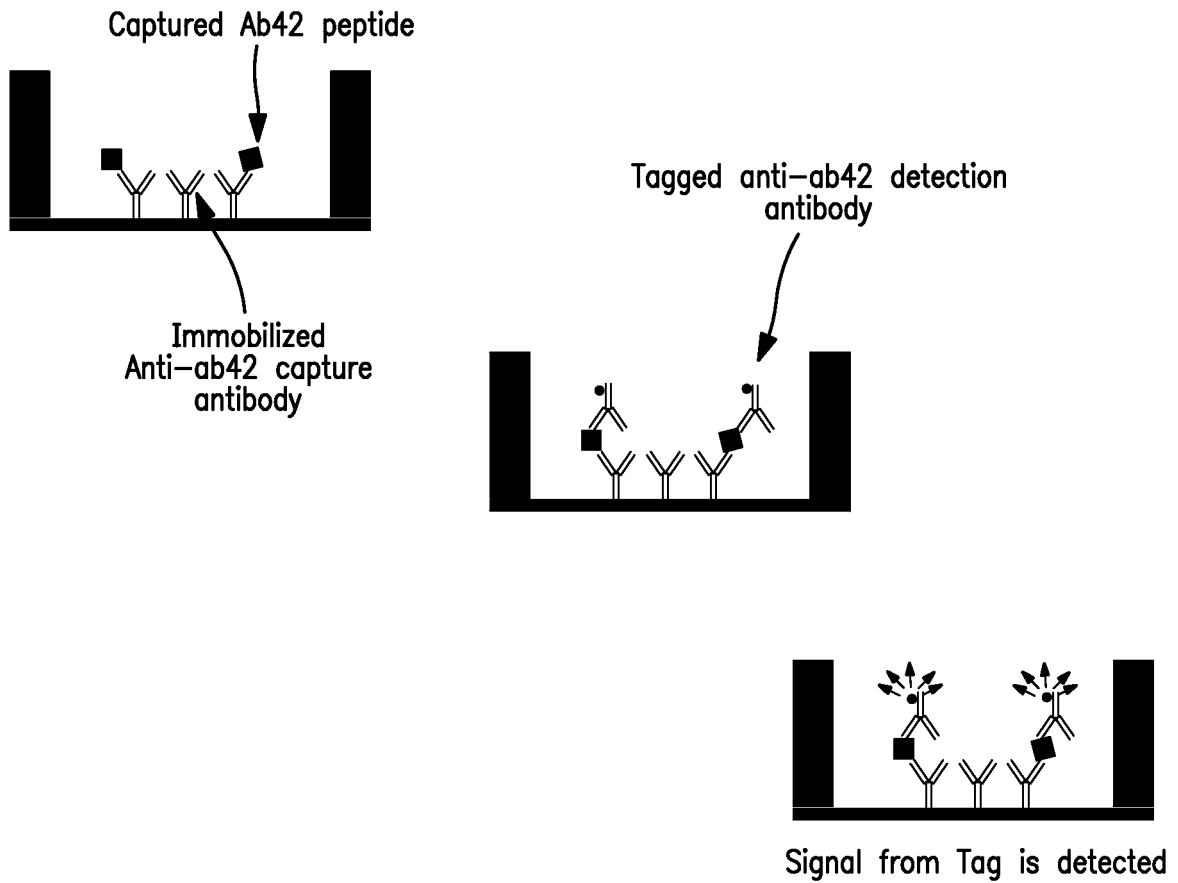

FIG. 1

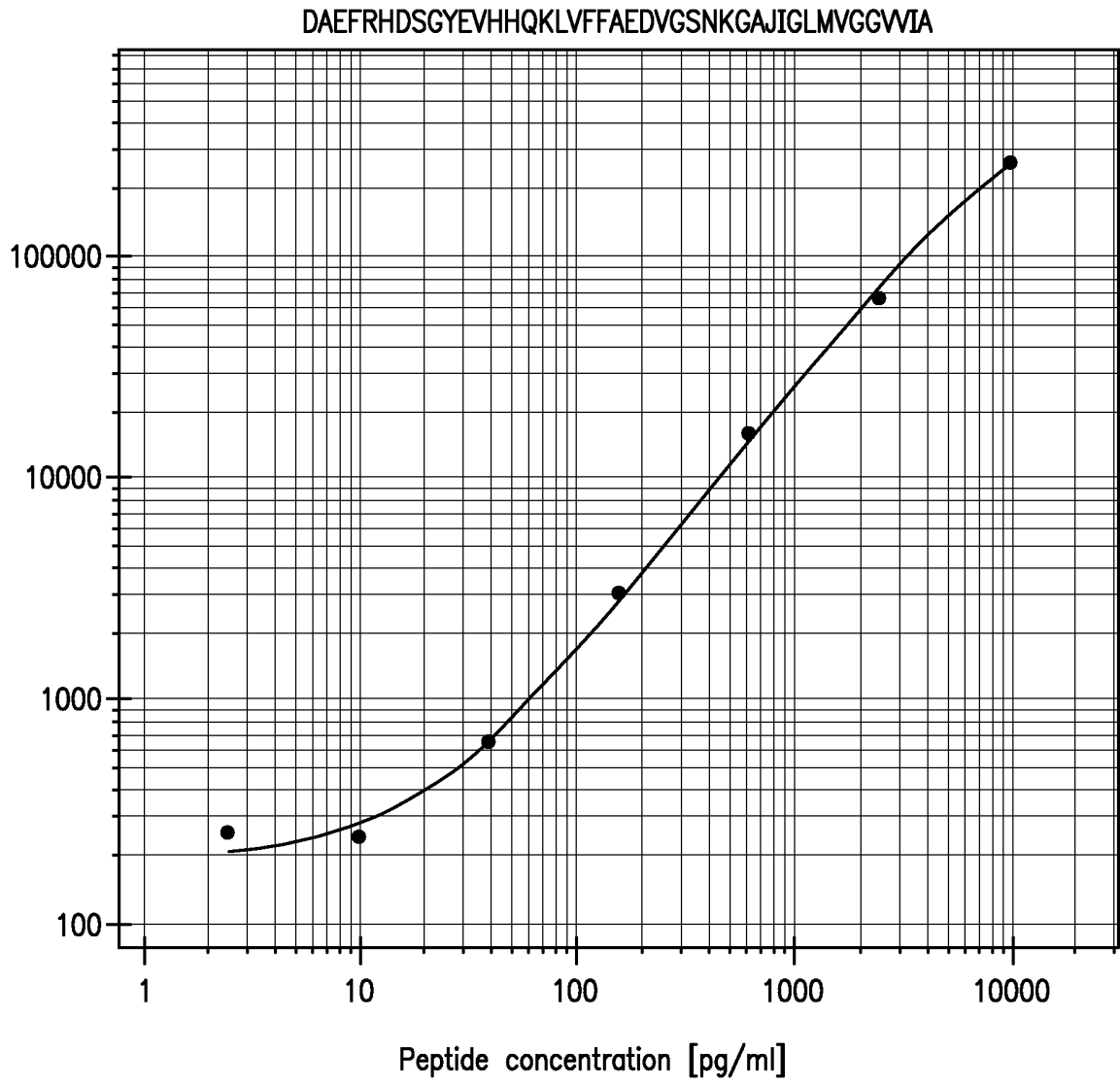

FIG. 2

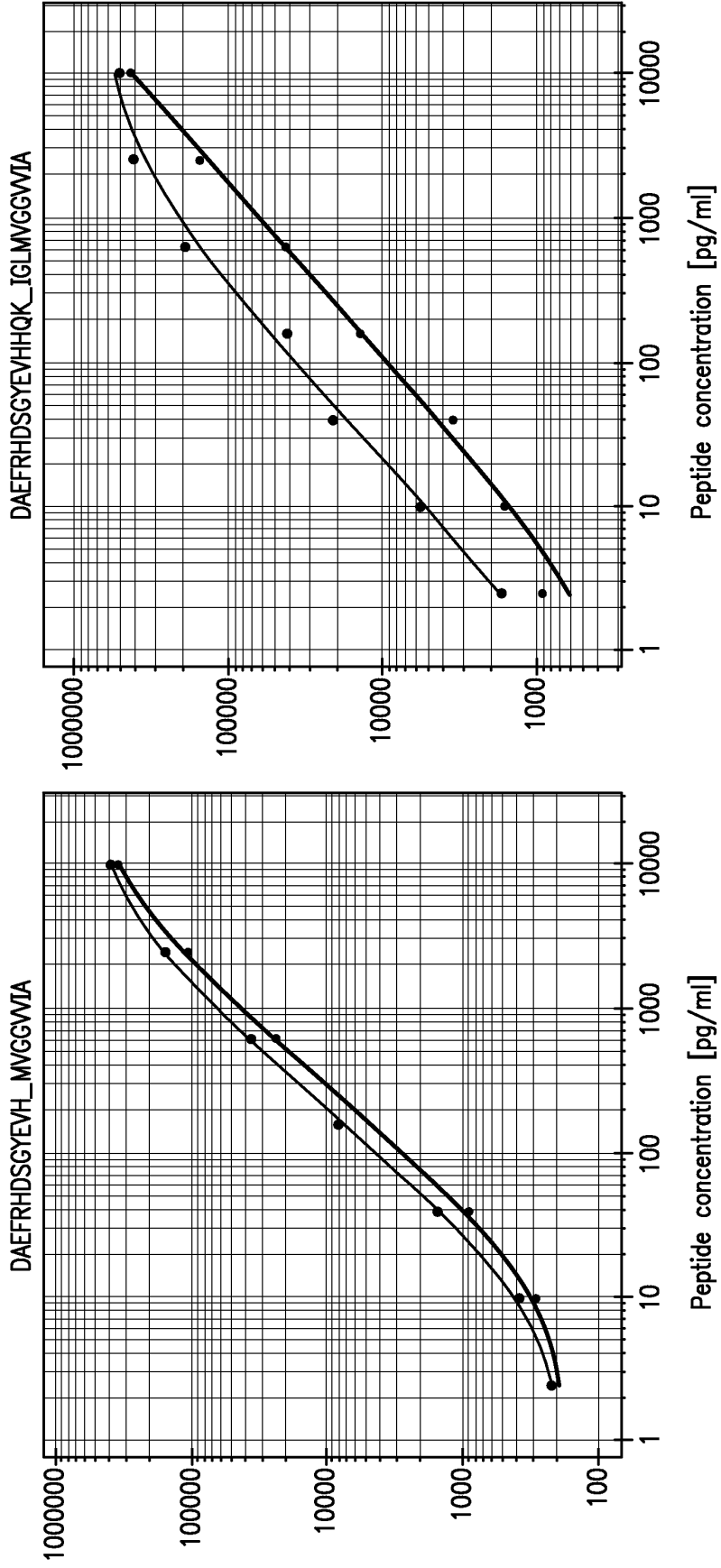

FIG. 3A

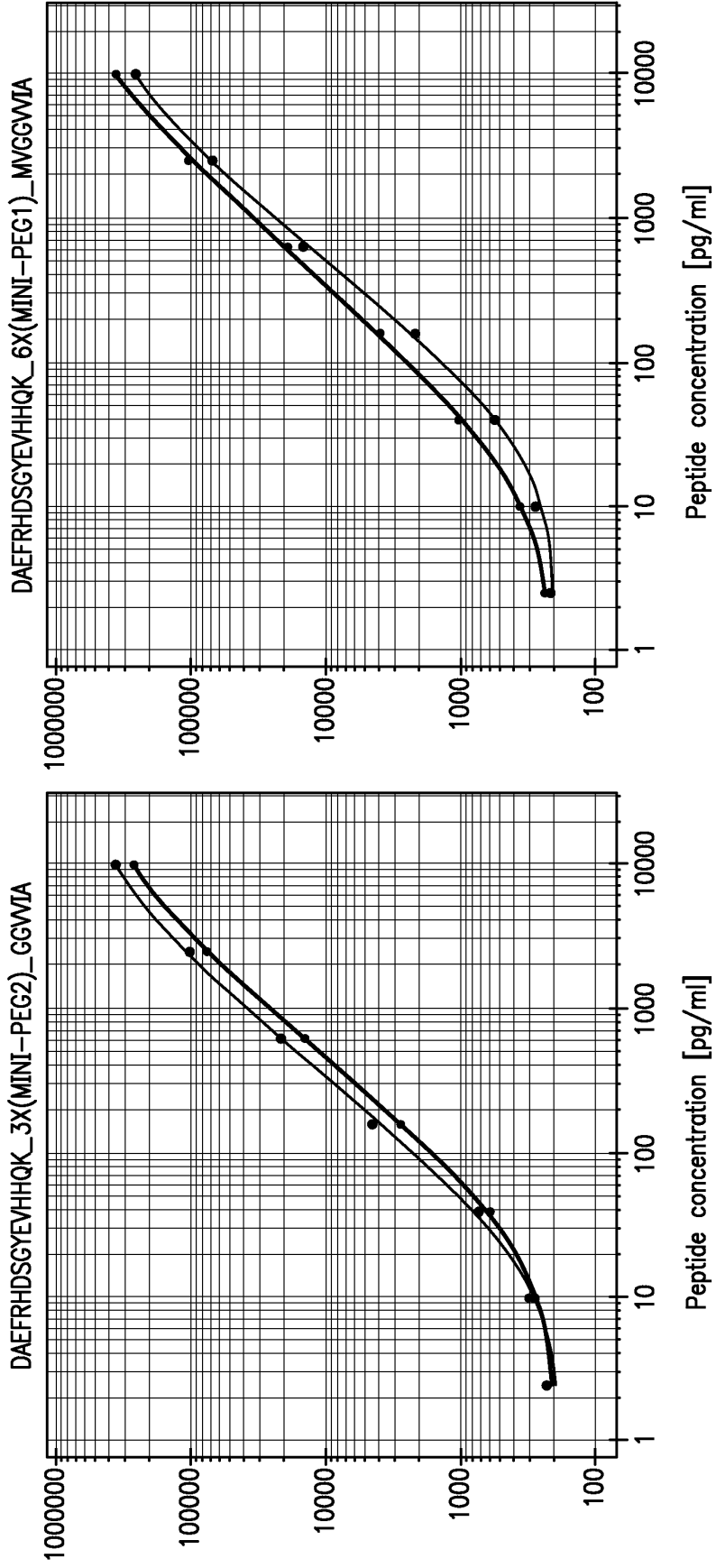

FIG. 3B

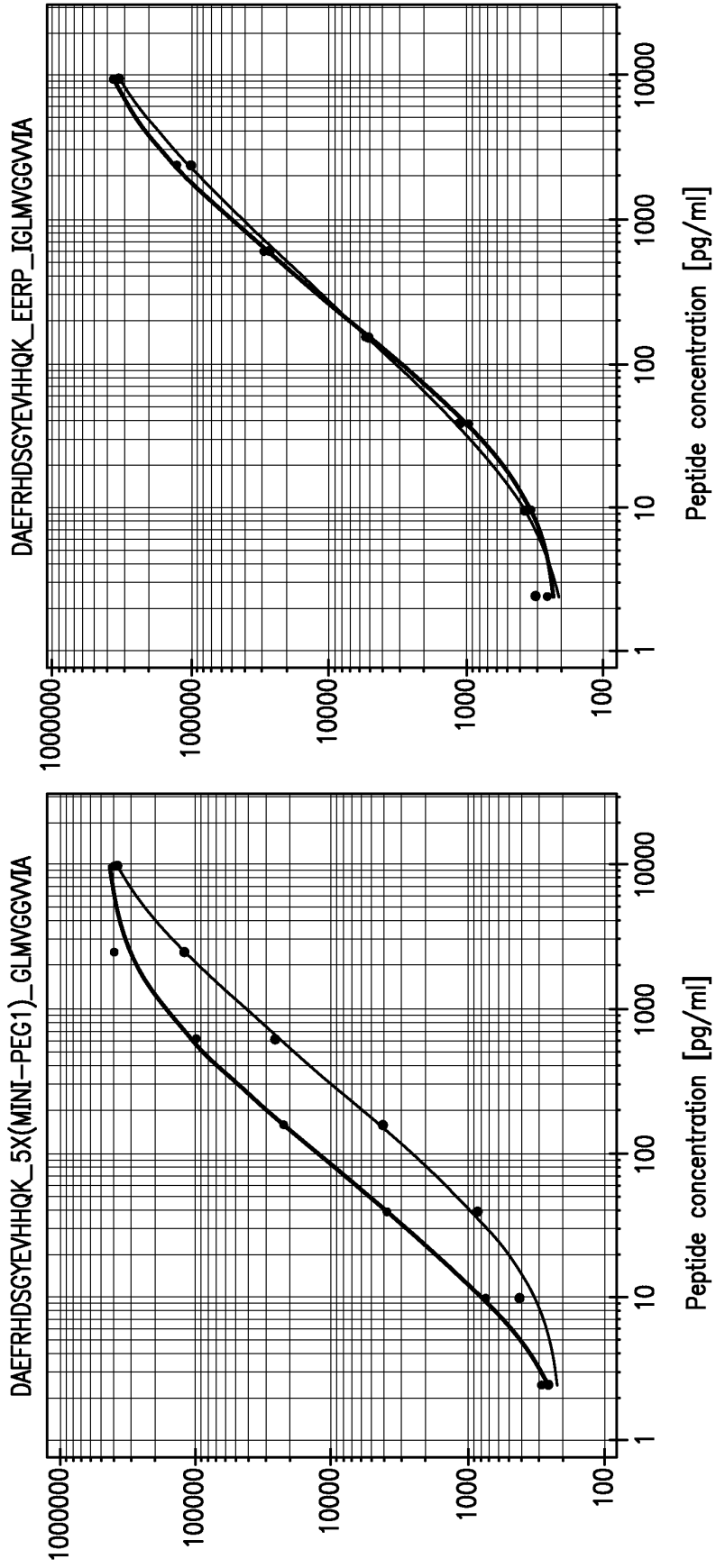

FIG. 3C

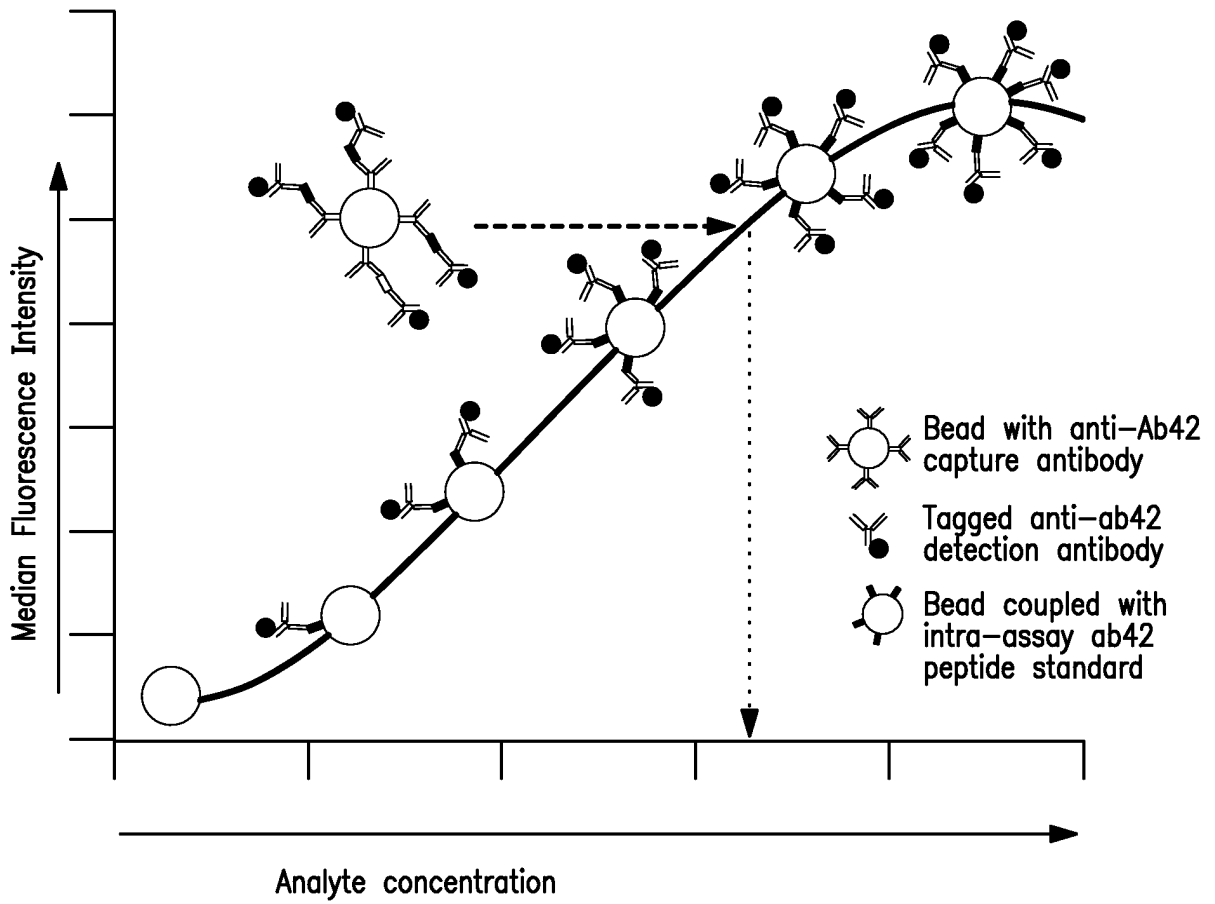

FIG. 4

Selected Bead Set #	A β ₄₀ peptide coupling concentration [μ g/35ml]	Median Fluorescence Intensity (MFI)
5	0	14
10	1	28
20	10	151
40	100	782
70	500	1944
90	5000	7869

FIG. 5A

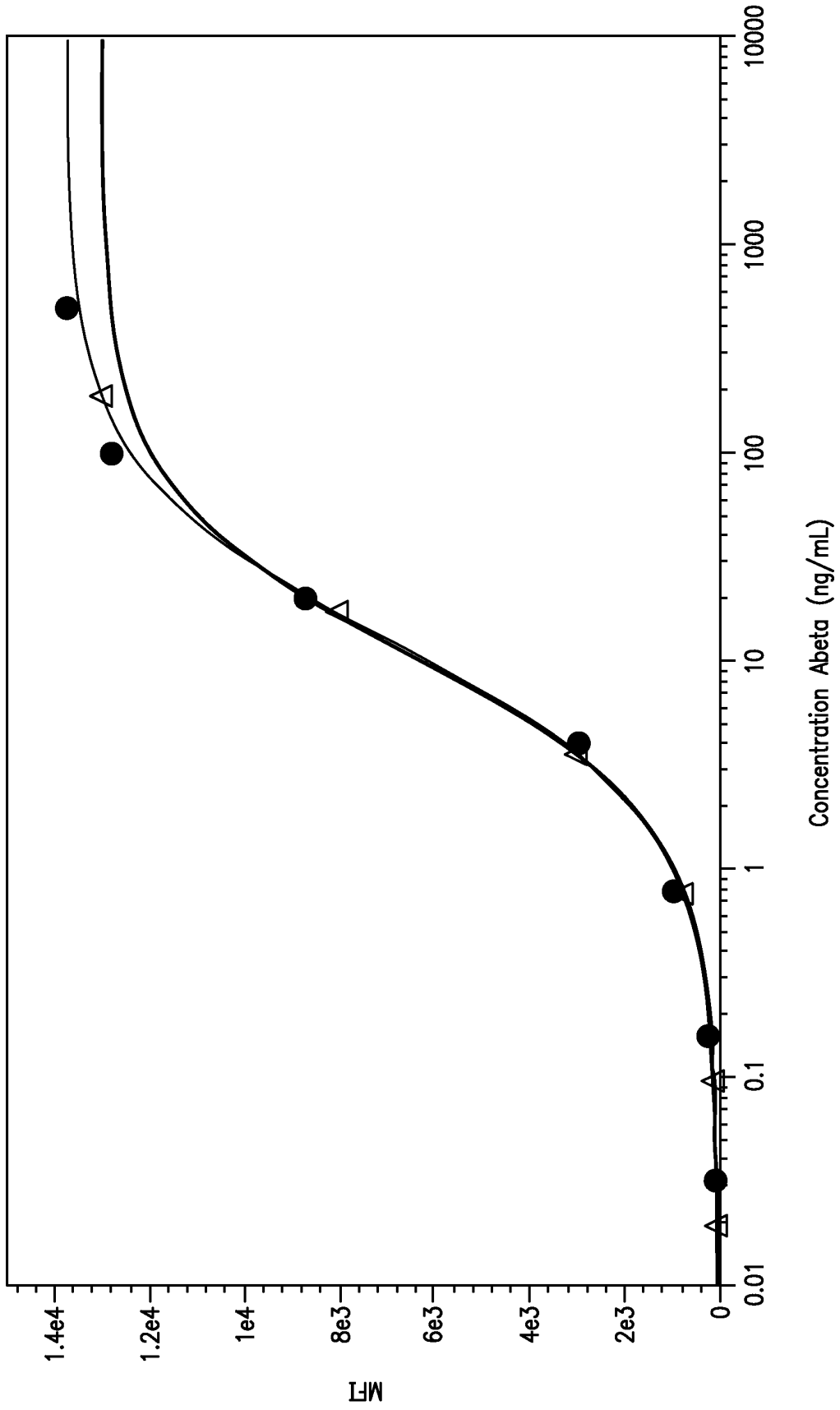

FIG. 5B

Sample	Results generated from Intra-assay $A\beta_{40}$ std curves (circles)	Results generated from $A\beta_{42}$ soluble std curves (triangles)
CSF-1	781 pg/ml	781 pg/ml
CSF-2	213 pg/ml	212 pg/ml
CSF-3	152 pg/ml	150 pg/ml
CSF-4	224 pg/ml	223 pg/ml

FIG. 5C

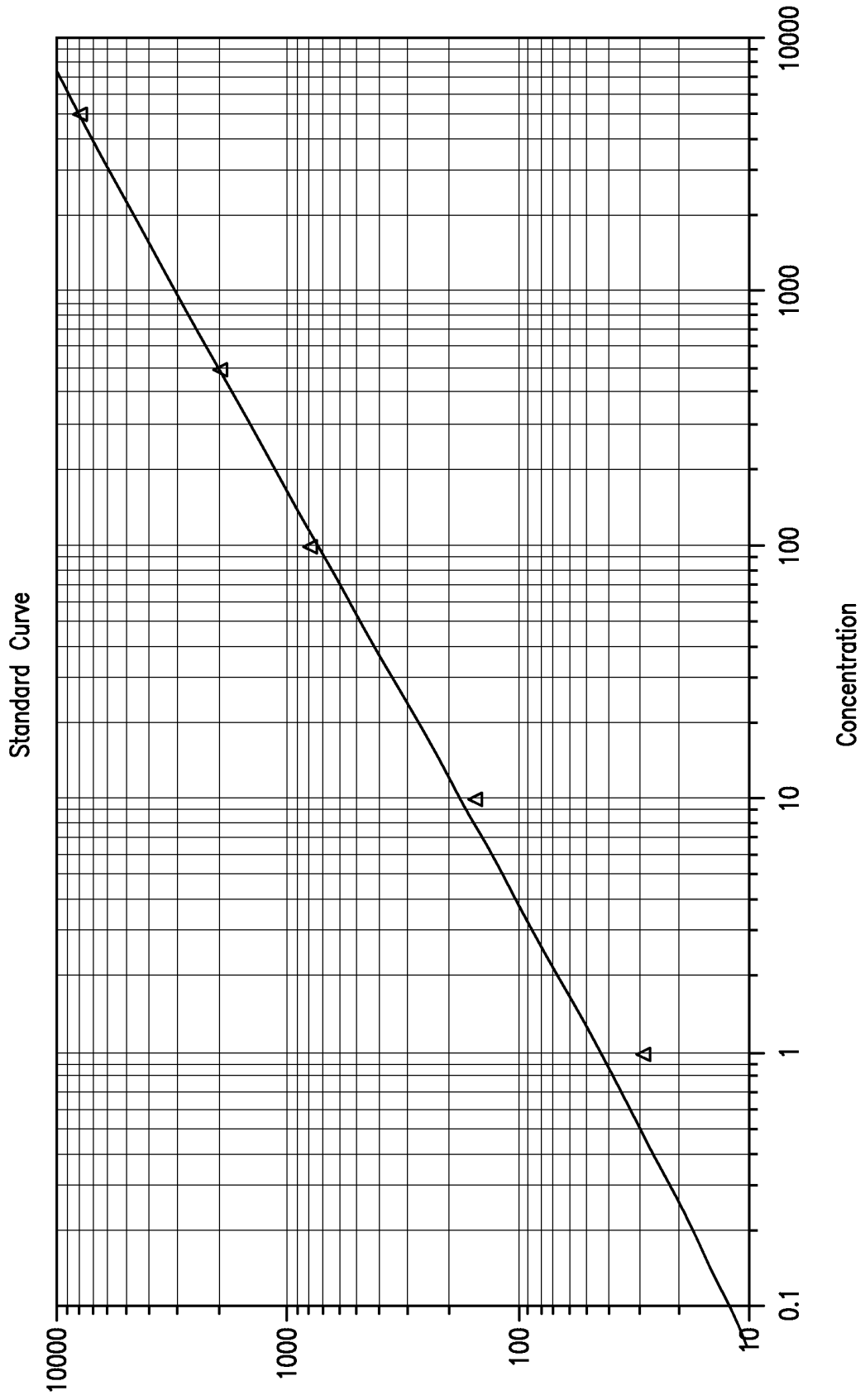

FIG. 6A

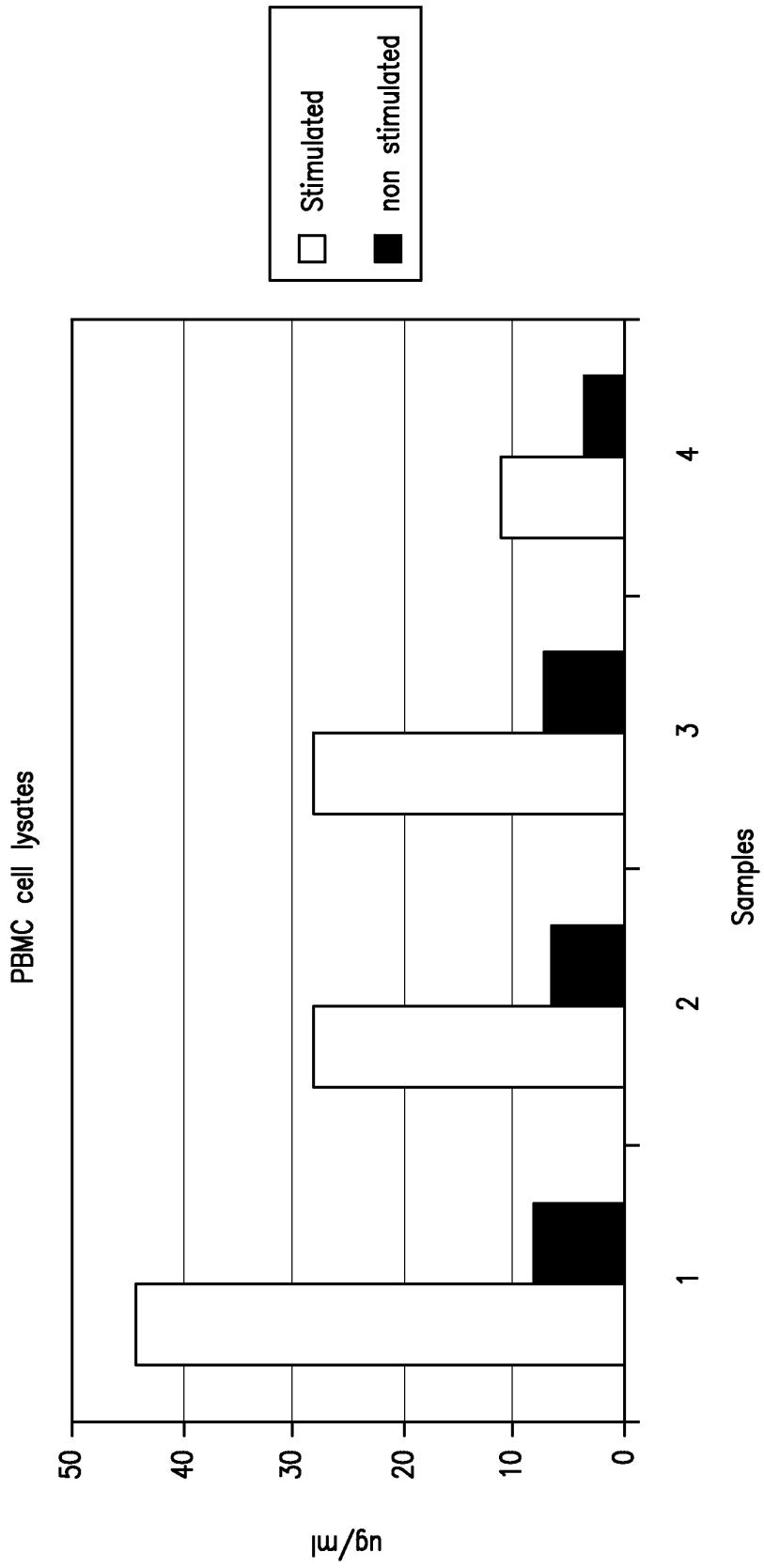

FIG. 6B

E2, E6 = Blank
buffer
E8 = Peptide #1
E12 = Peptide #2
E15 = Peptide #3
E17 = Peptide #4
E19 = A β (1-42)

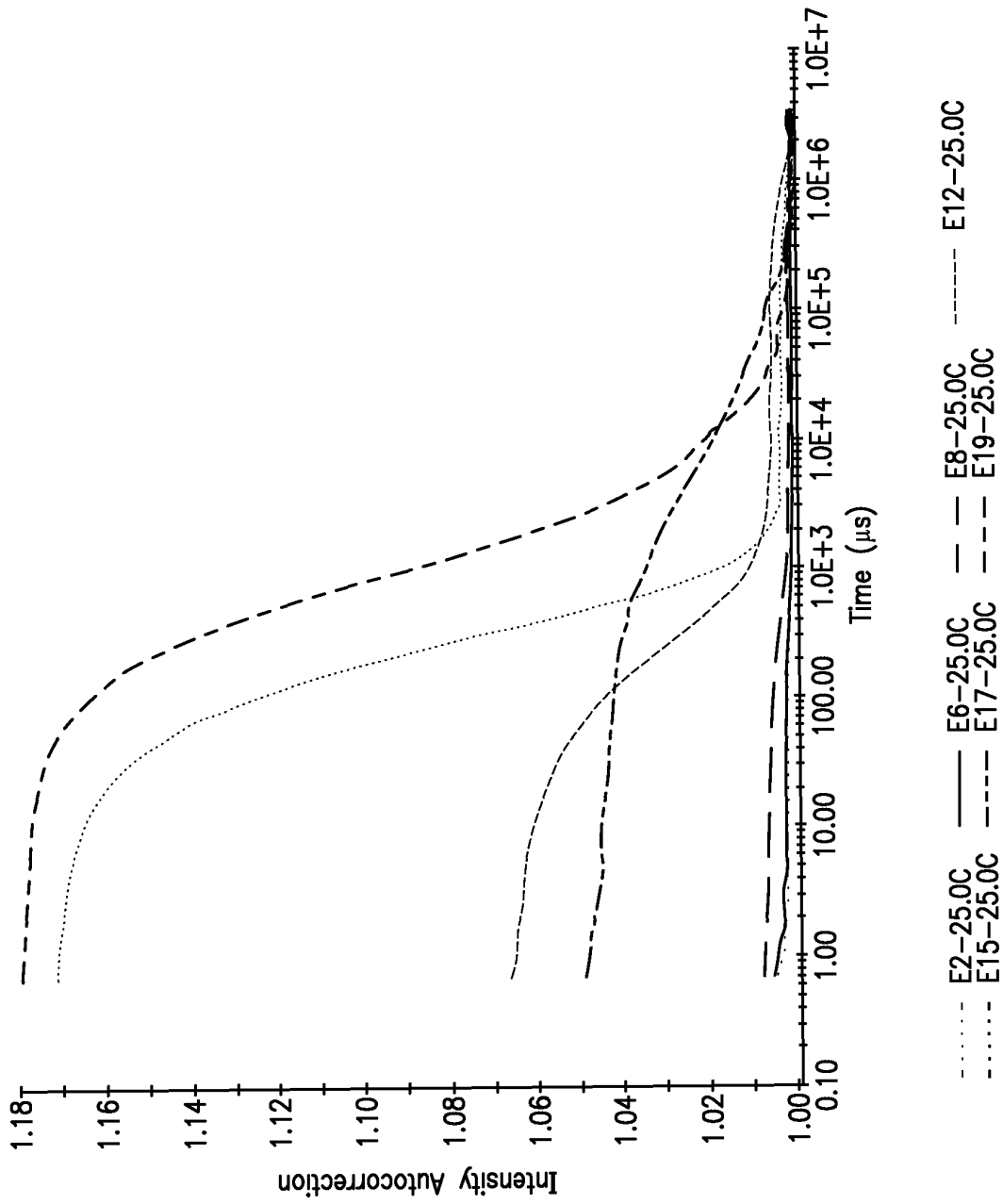

FIG. 7A

FL Aβ 1-42

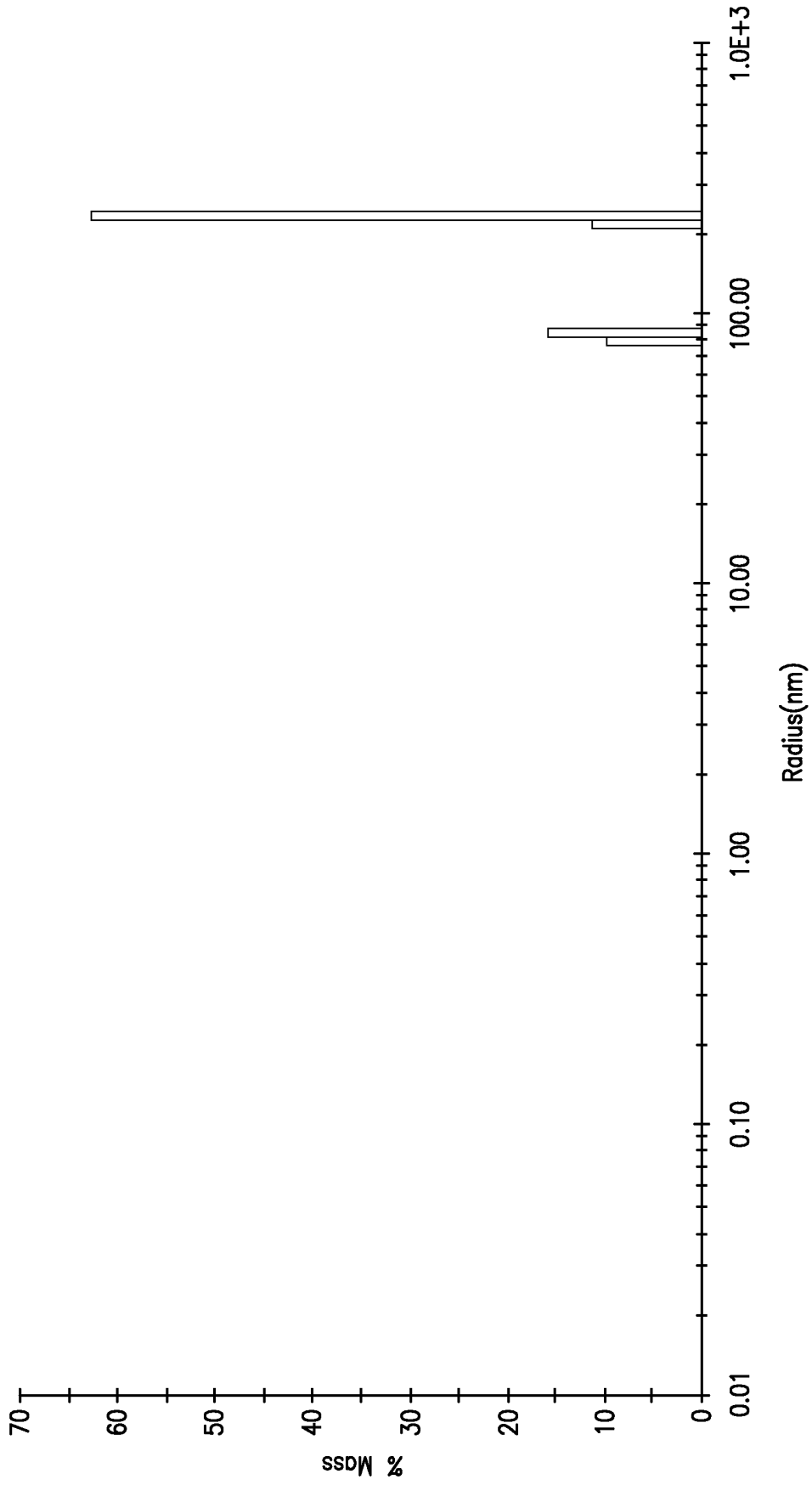

FIG. 7B

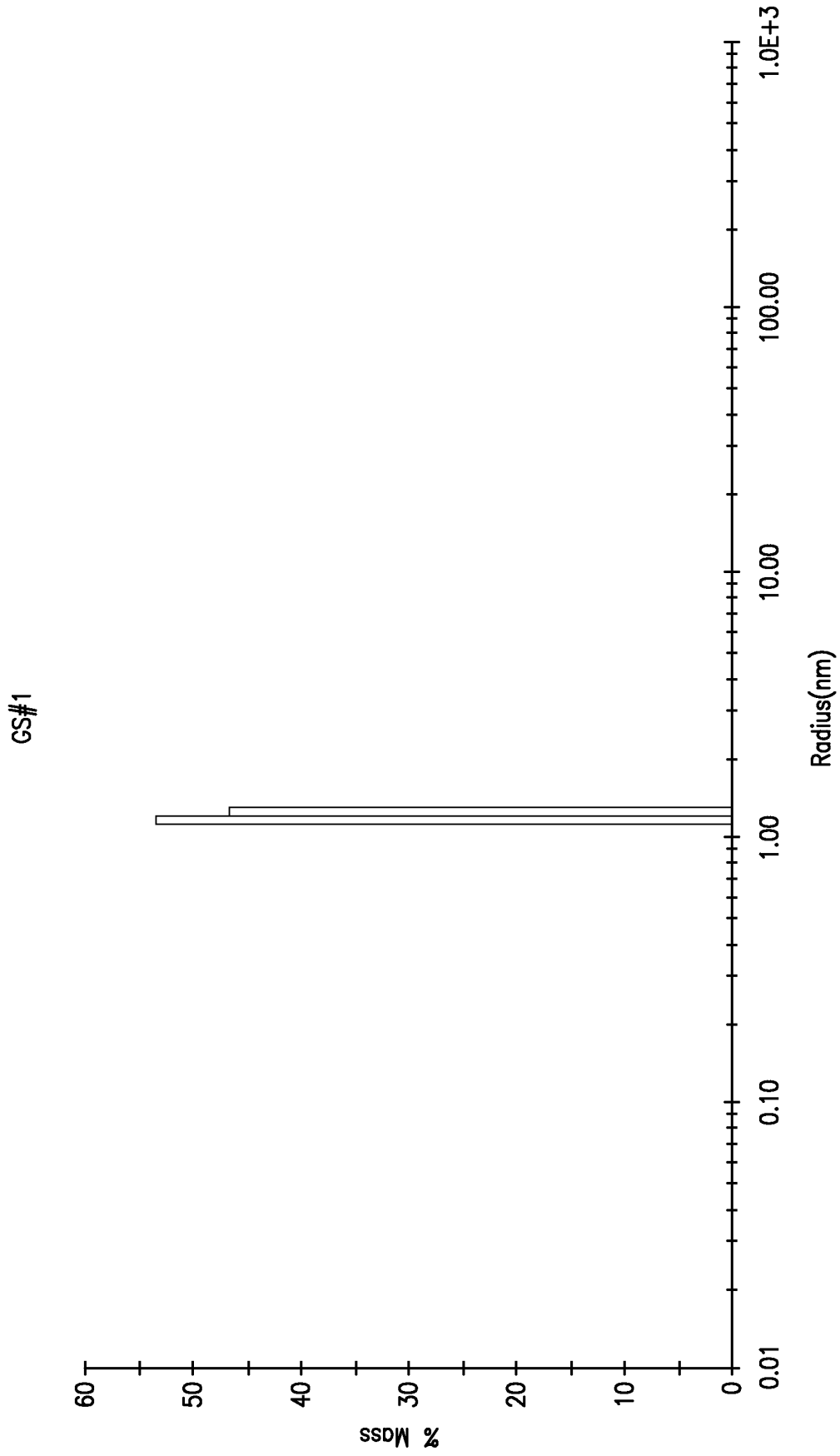

FIG. 7C

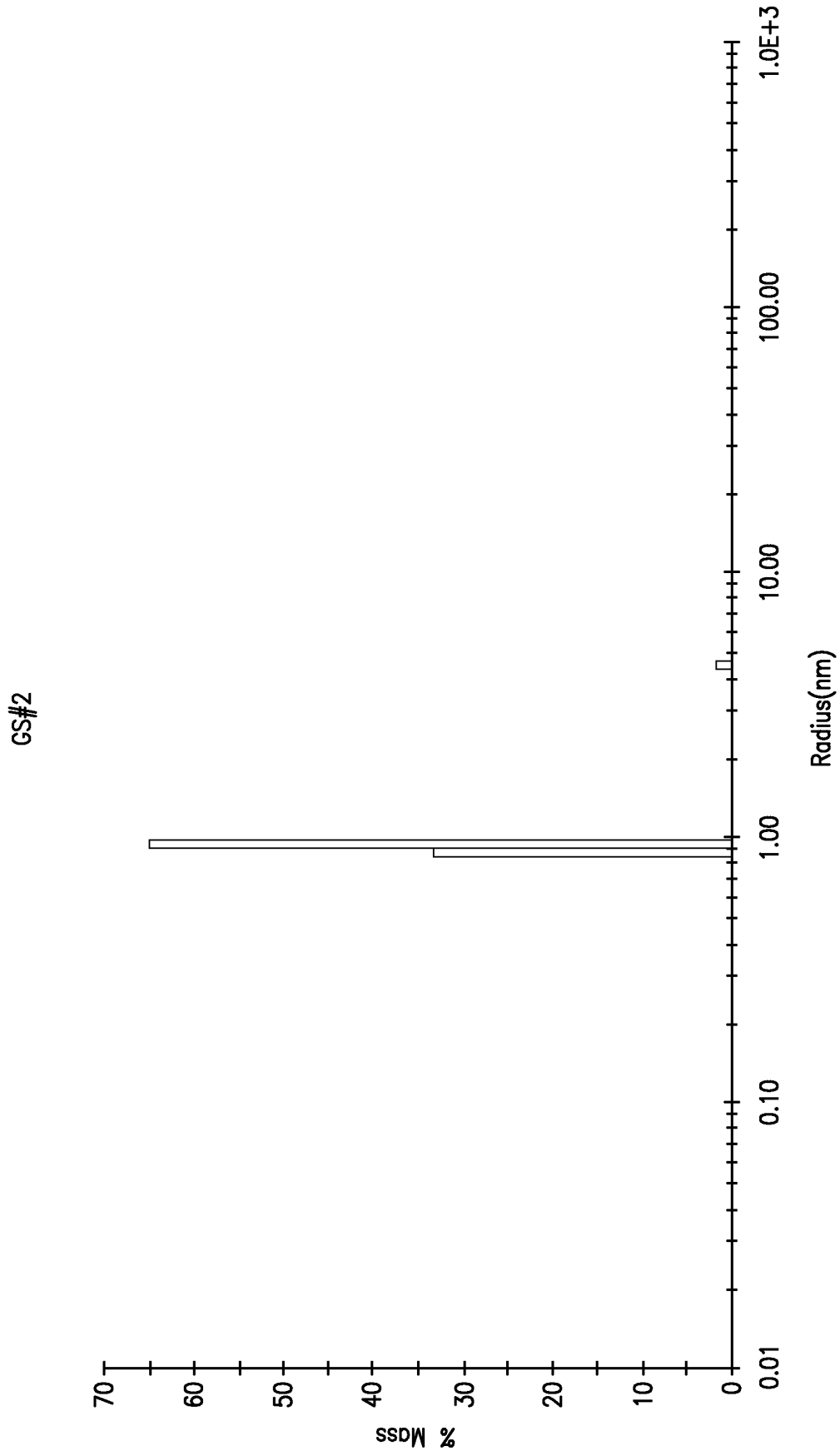

FIG. 7D

CS#3

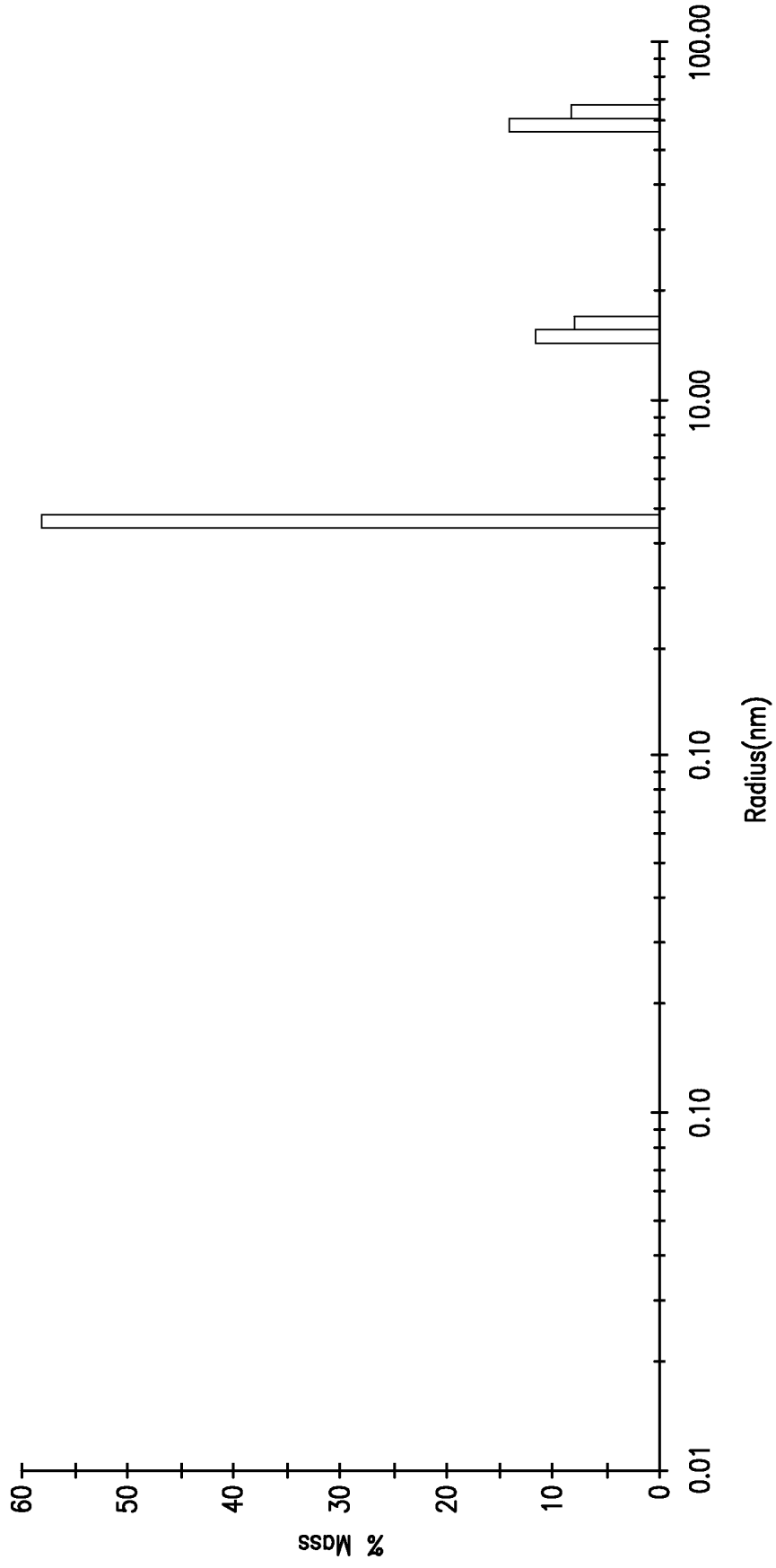

FIG. 7E

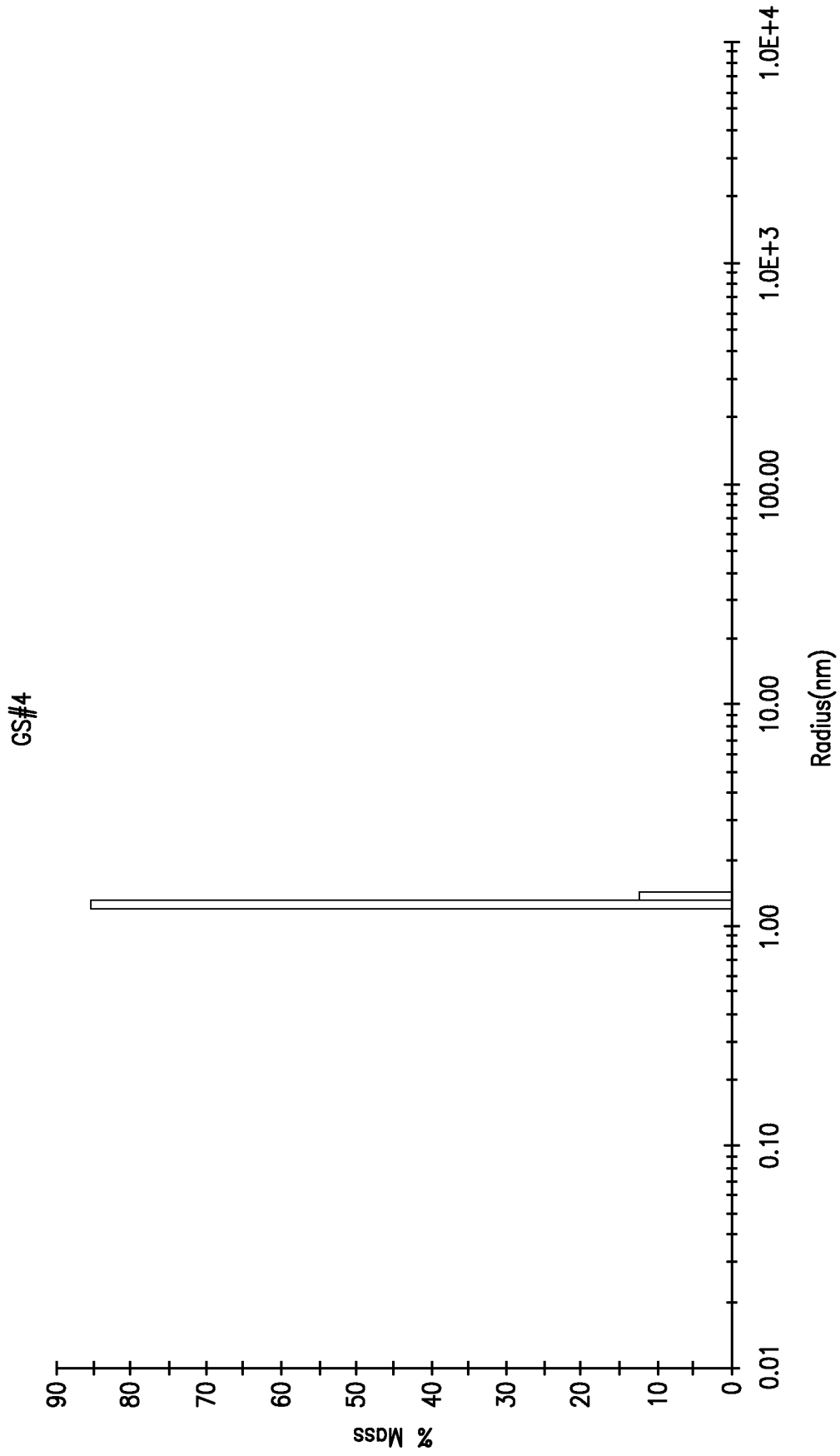
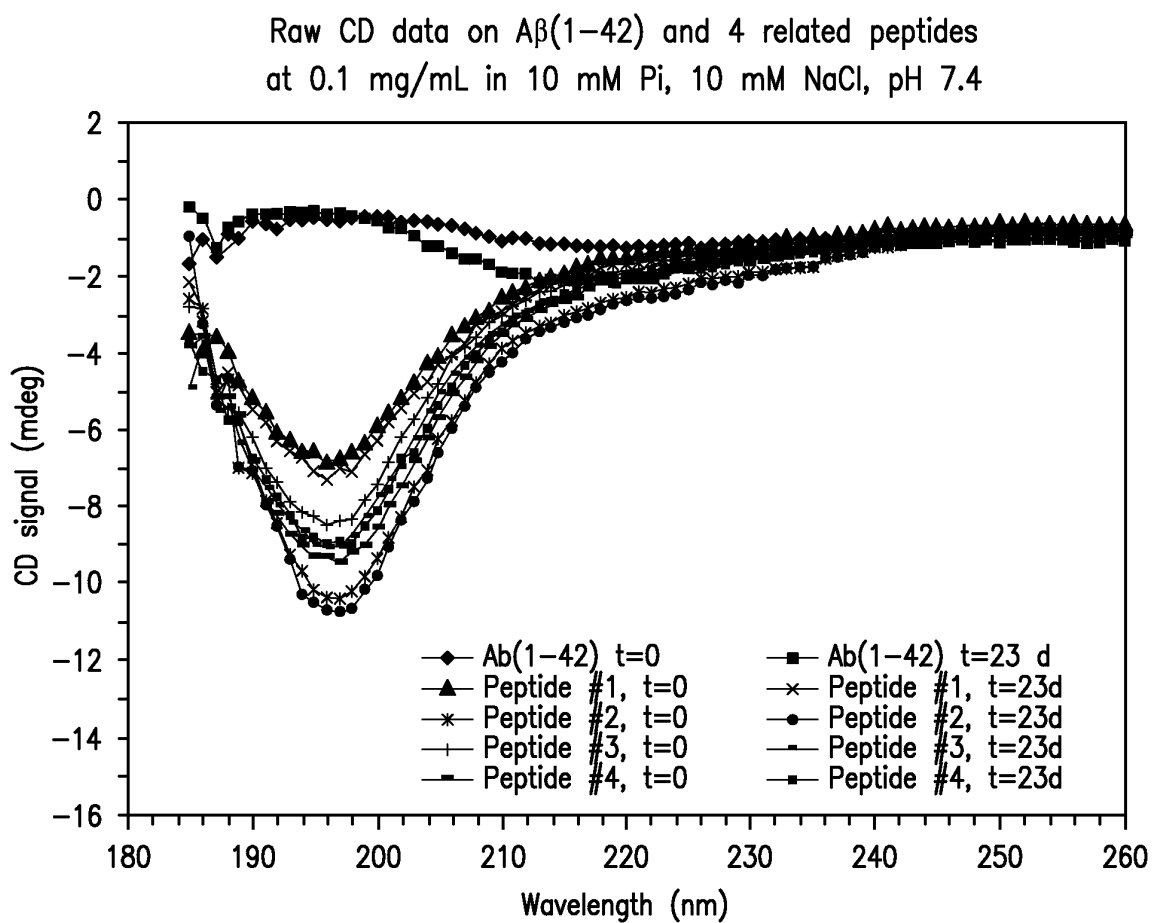

FIG. 7F

**FIG. 8**

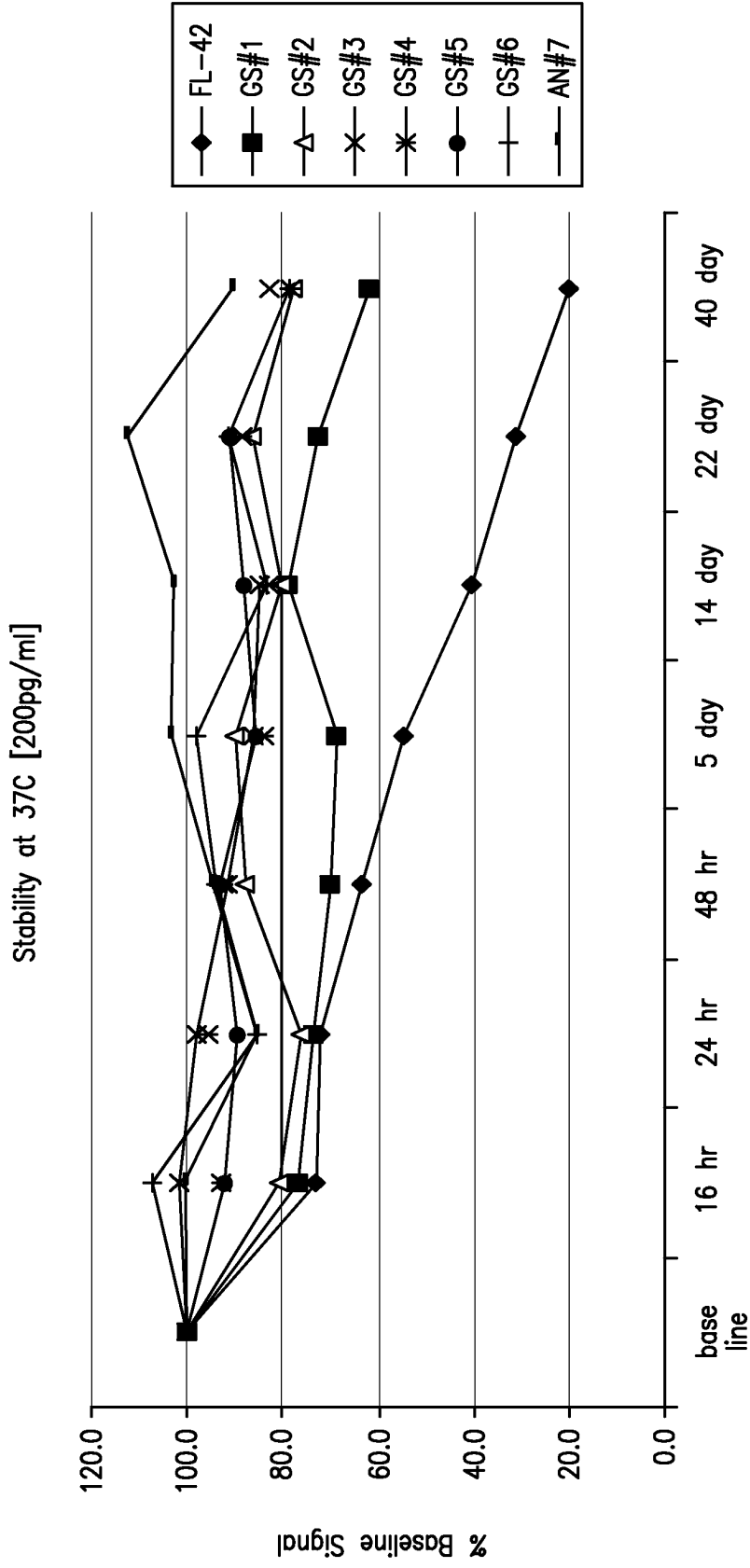

FIG. 9A

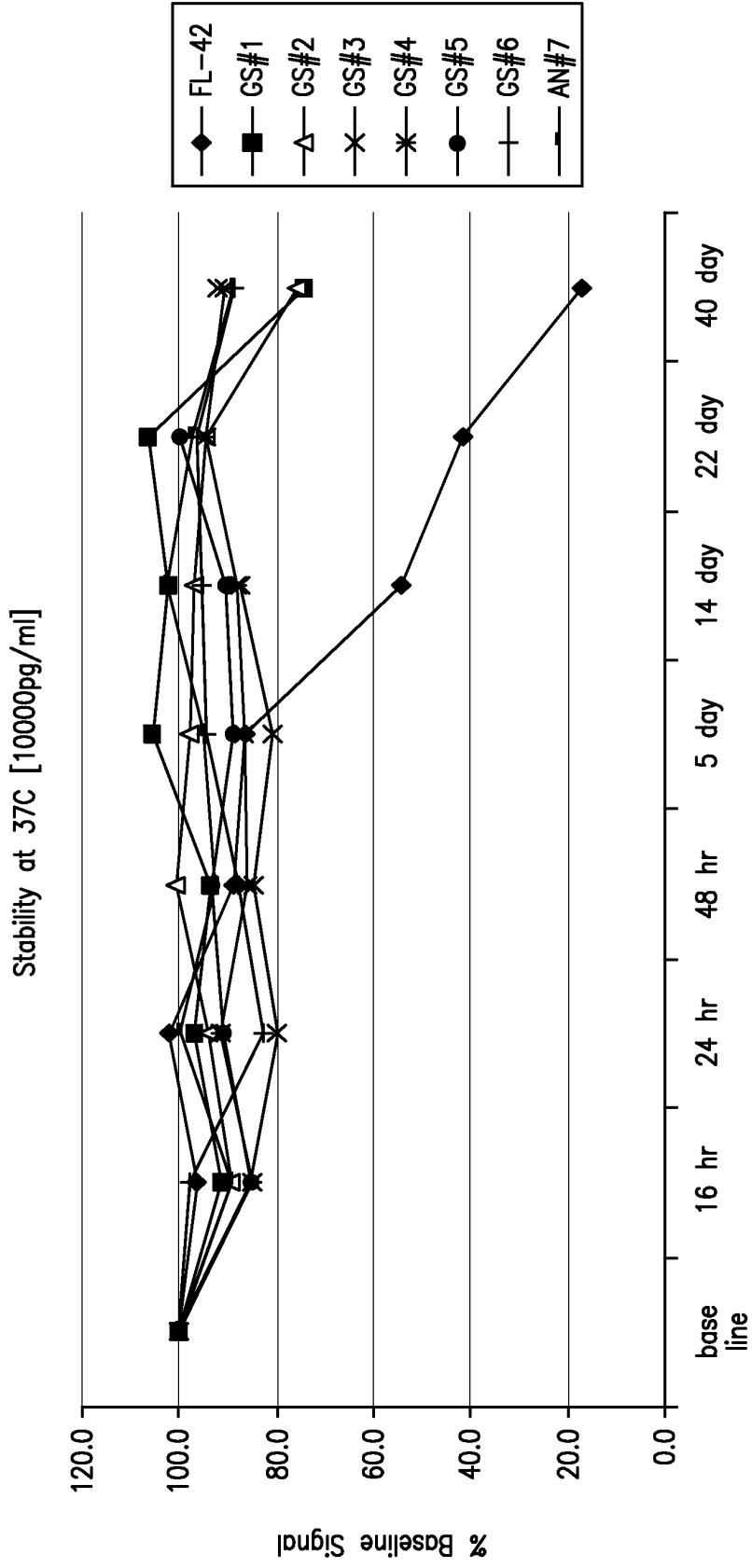

FIG. 9B

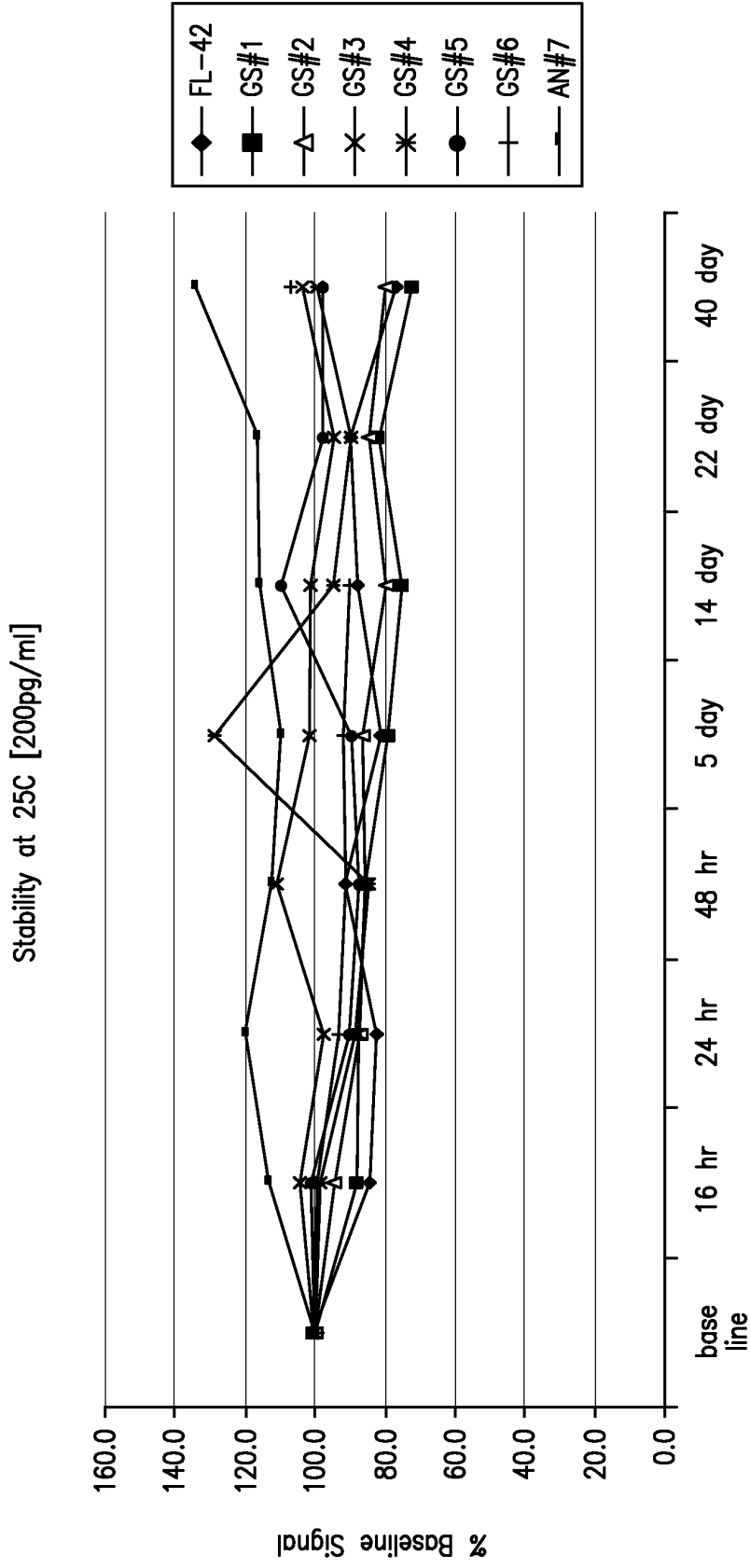

FIG. 9C

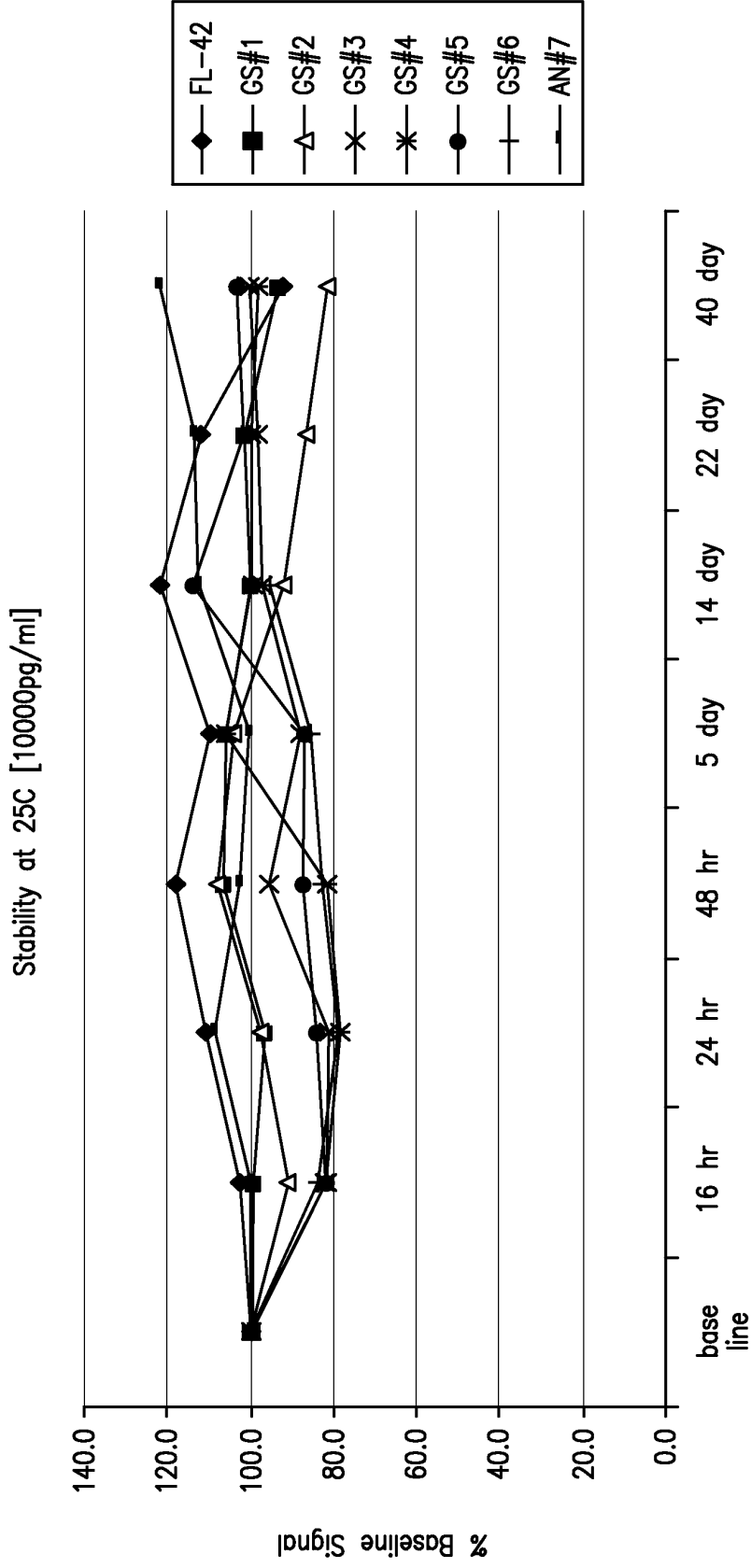

FIG. 9D

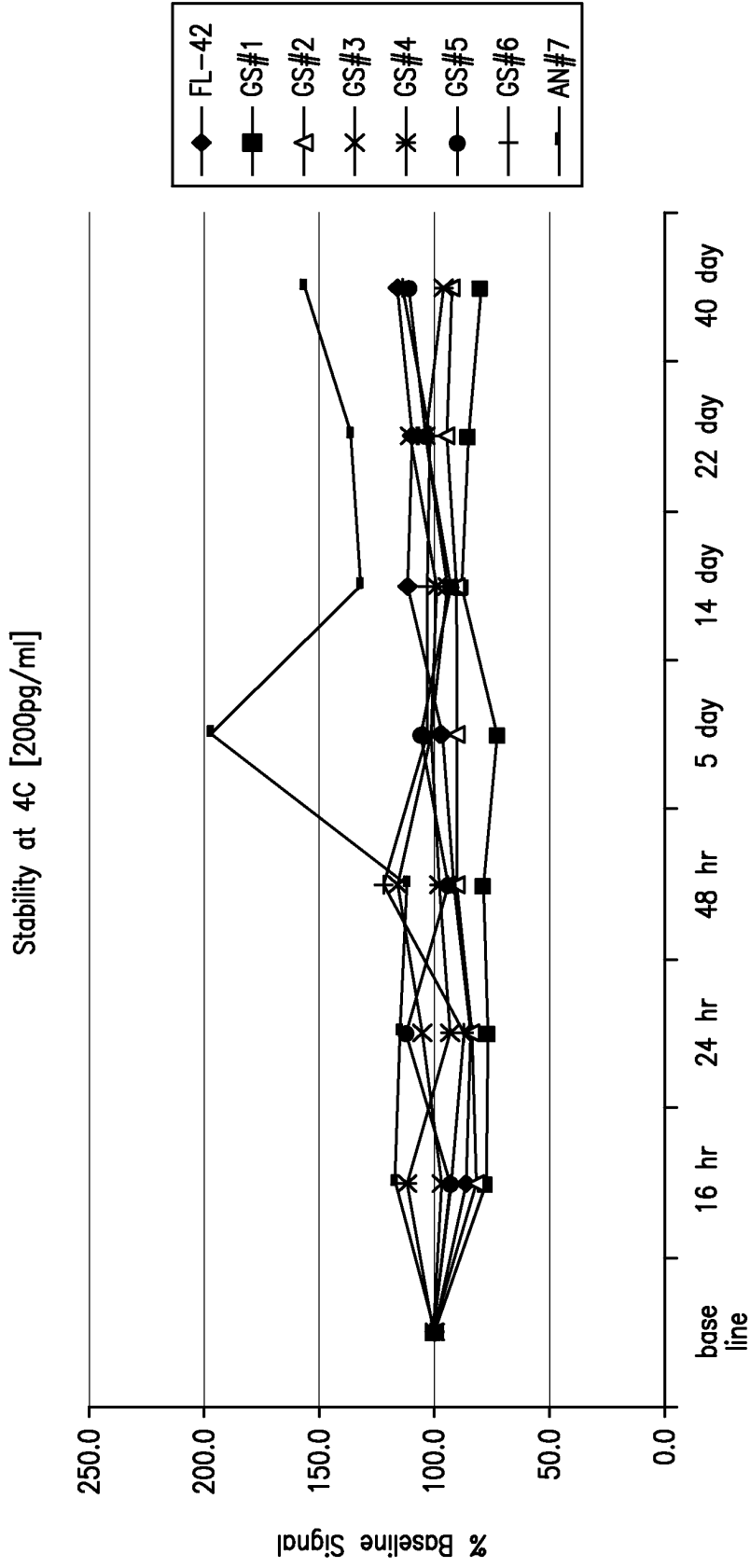

FIG. 9E

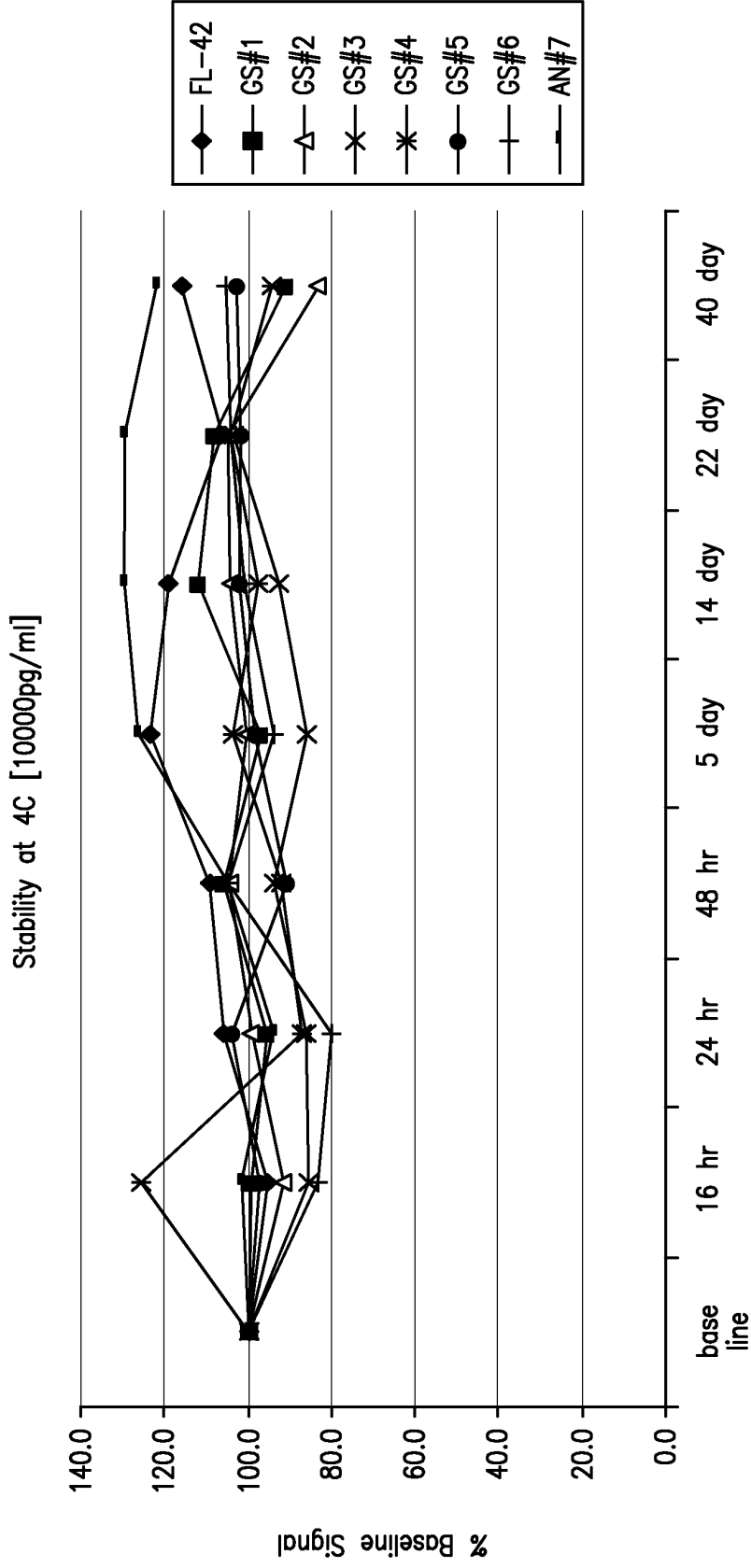

FIG. 9F

FLAb 1-42 at 25 C

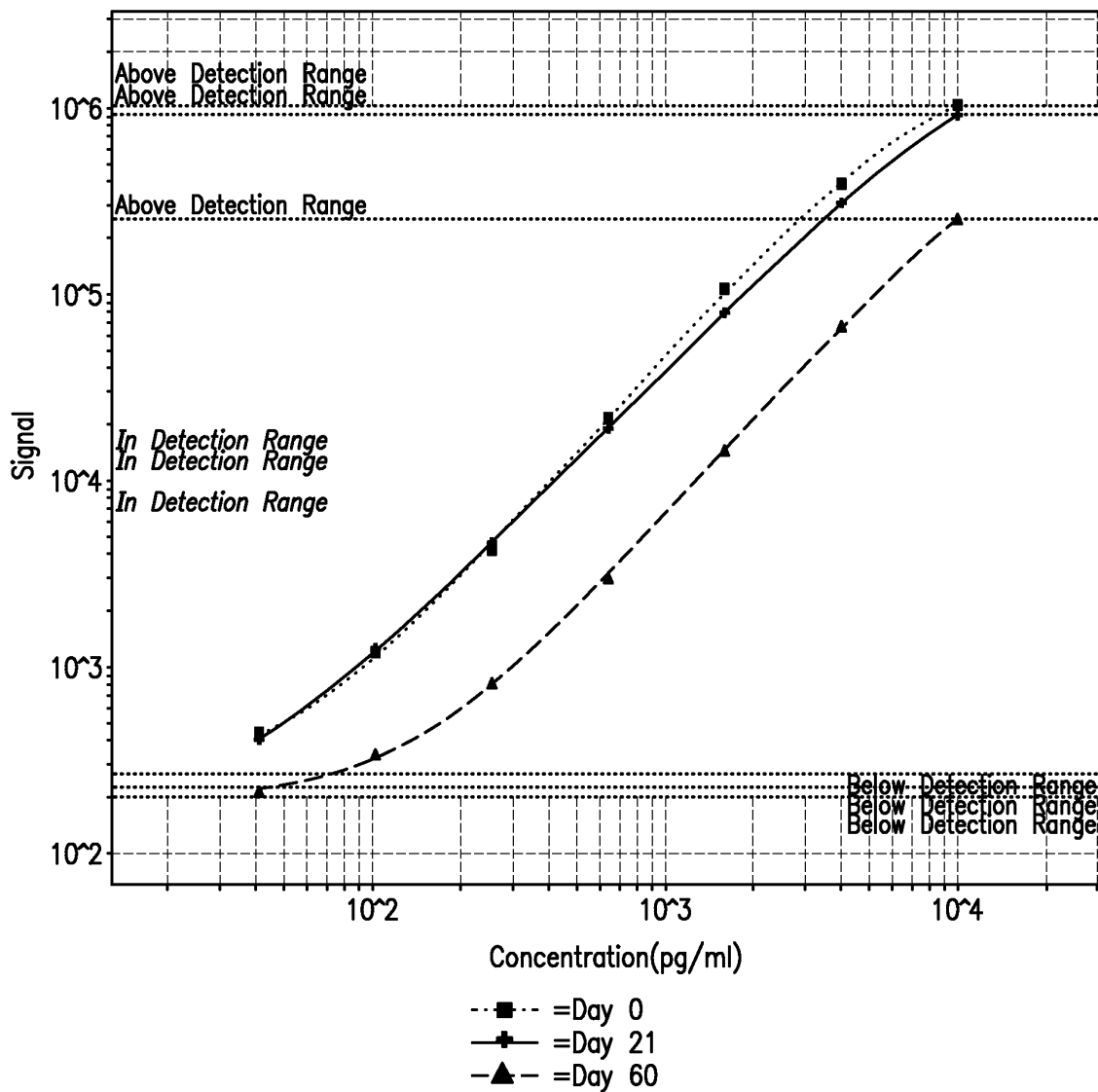

FIG. 10A

FLAb 1-42 at 37 C

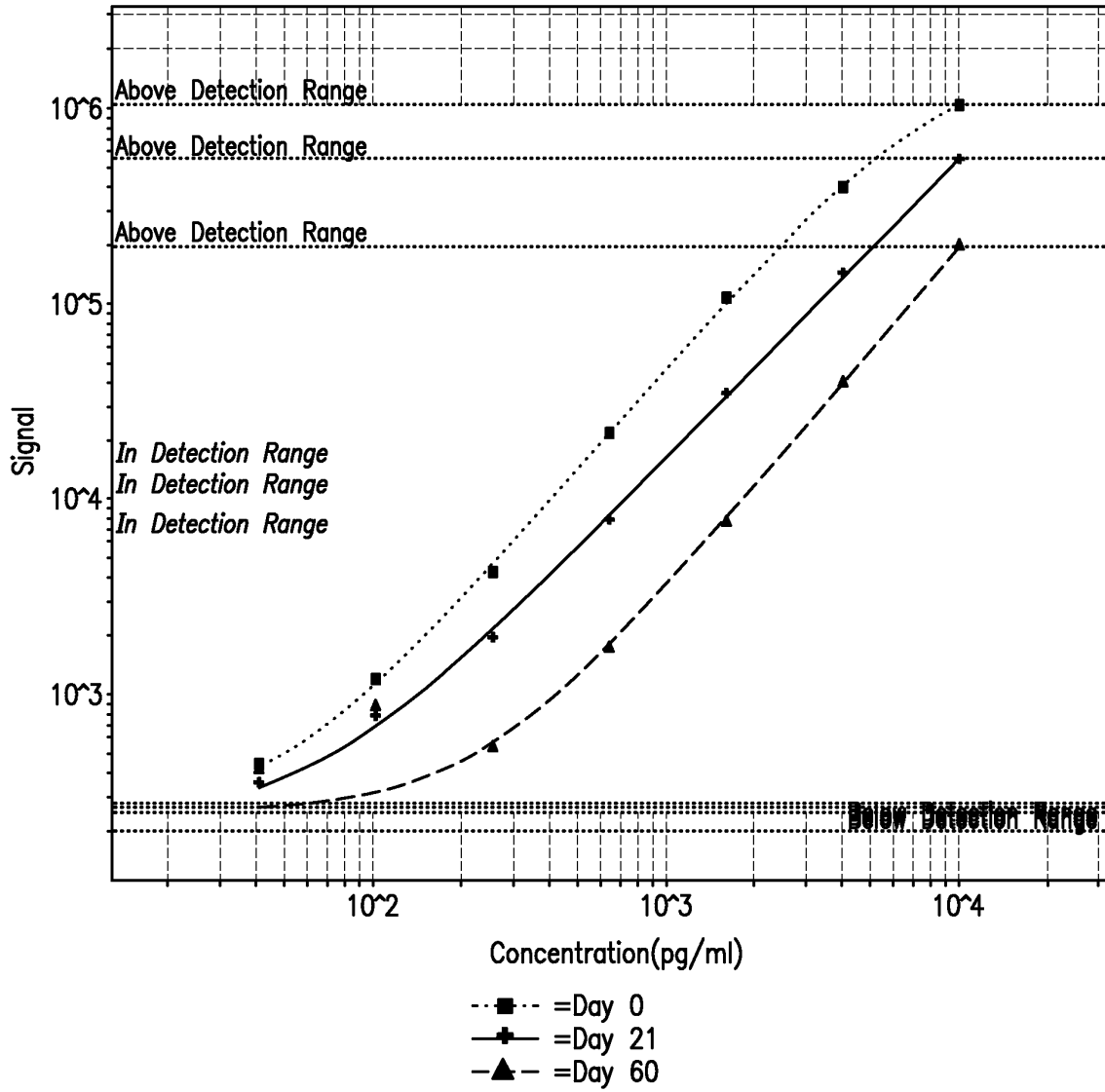

FIG. 10B

GS#1 at 37 C

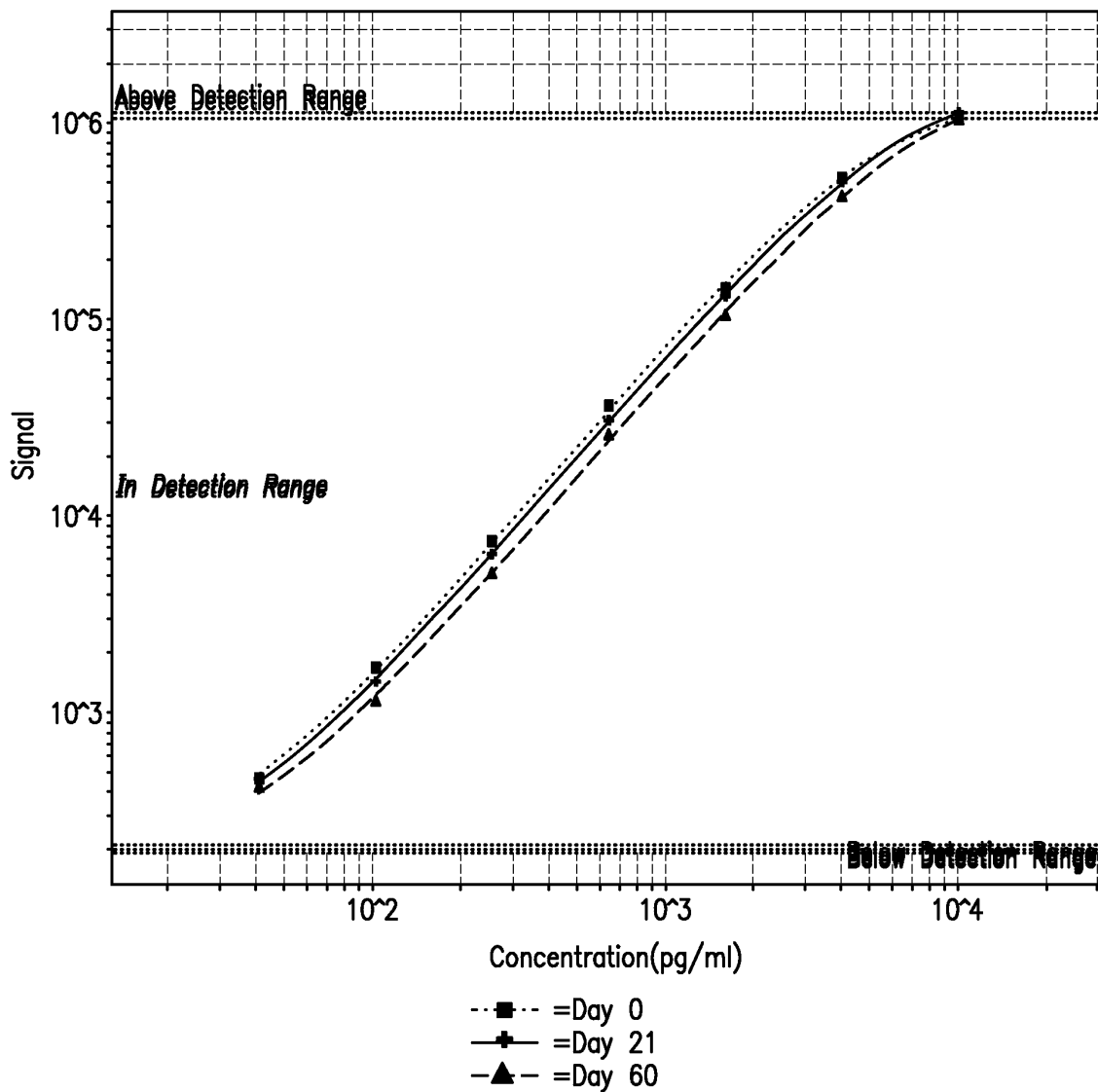

FIG. 10C

GS#2 at 37C

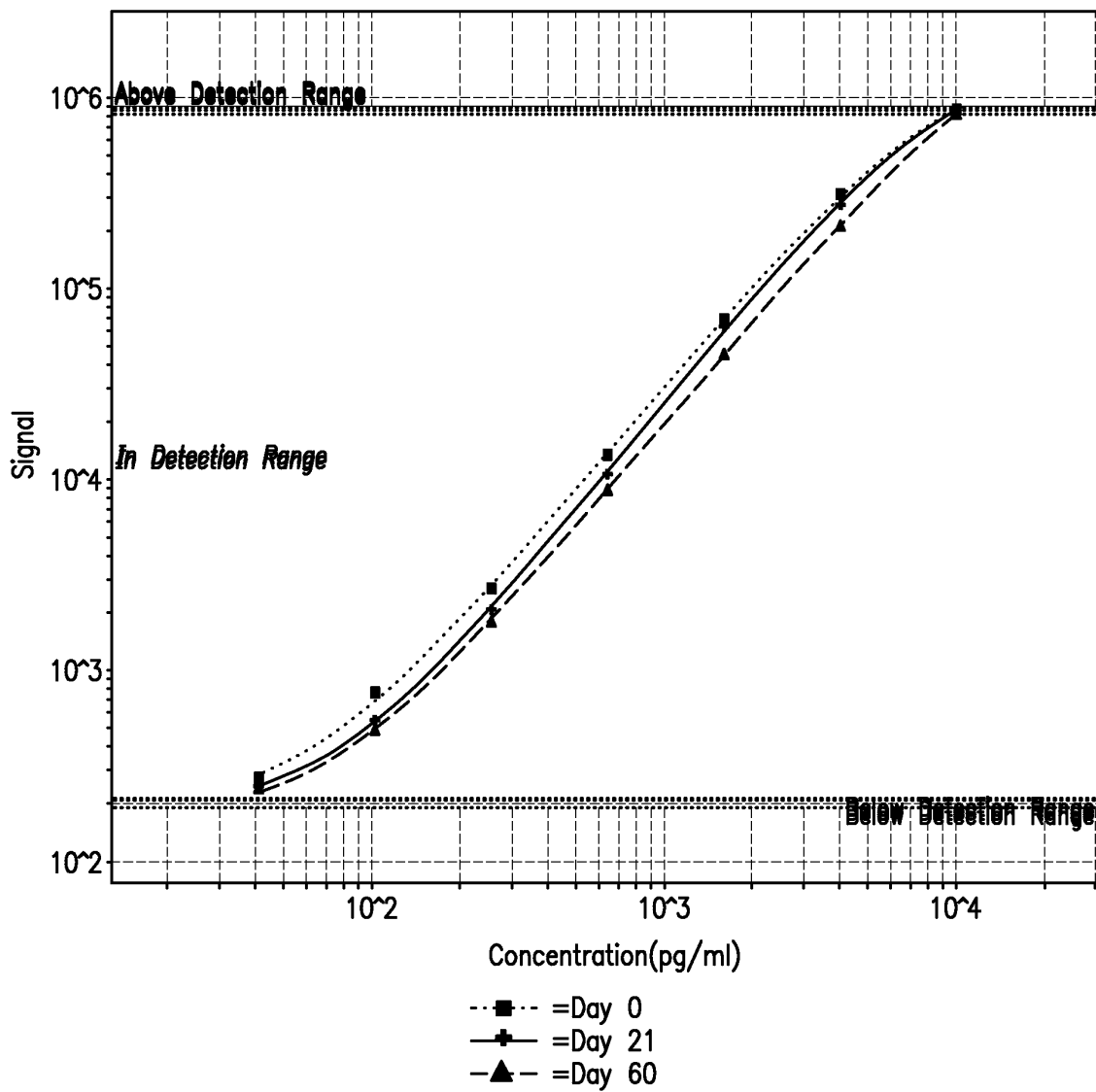

FIG. 10D

GS#3 at 37 C

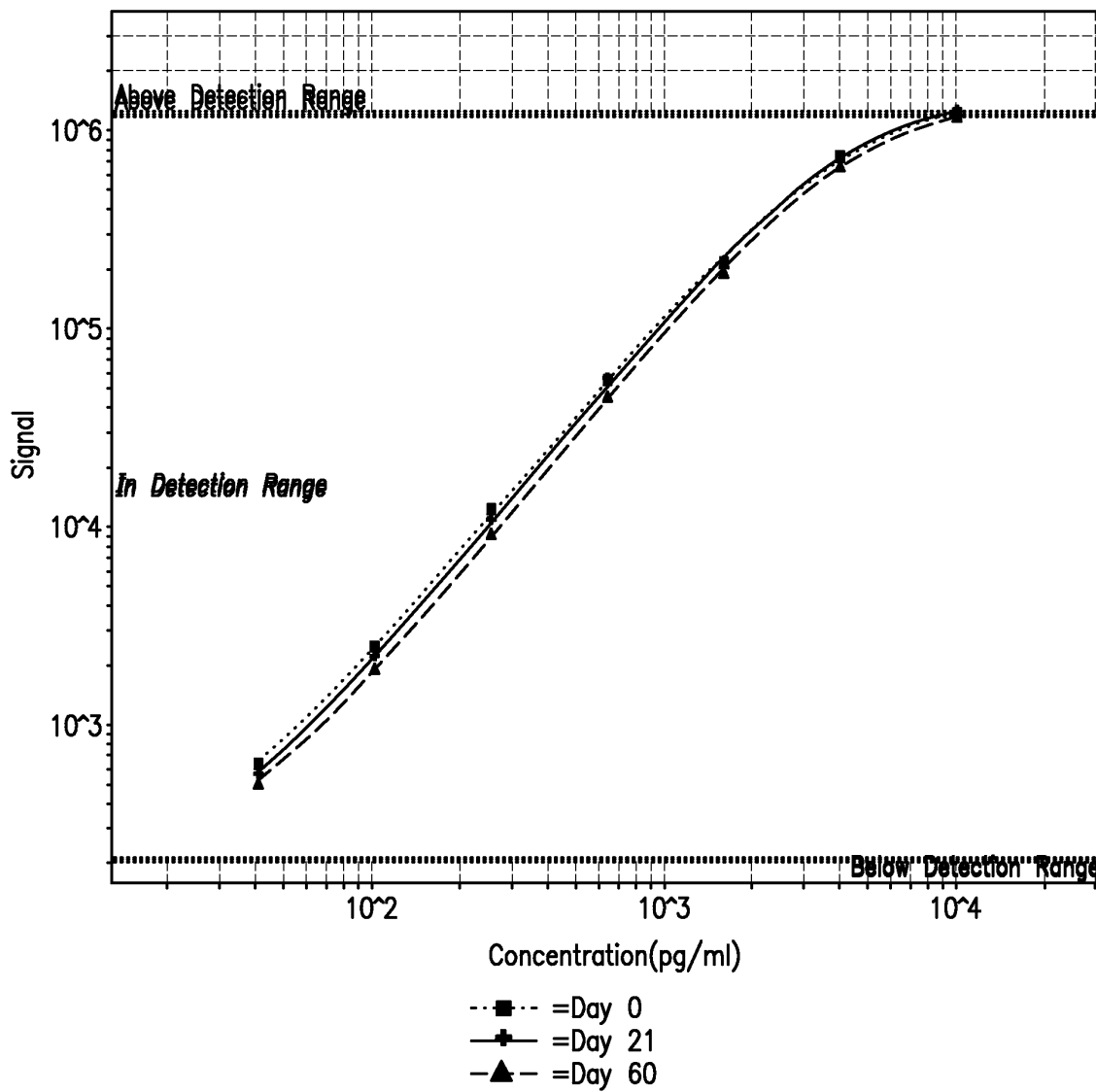

FIG. 10E

GS#4 at 37 C

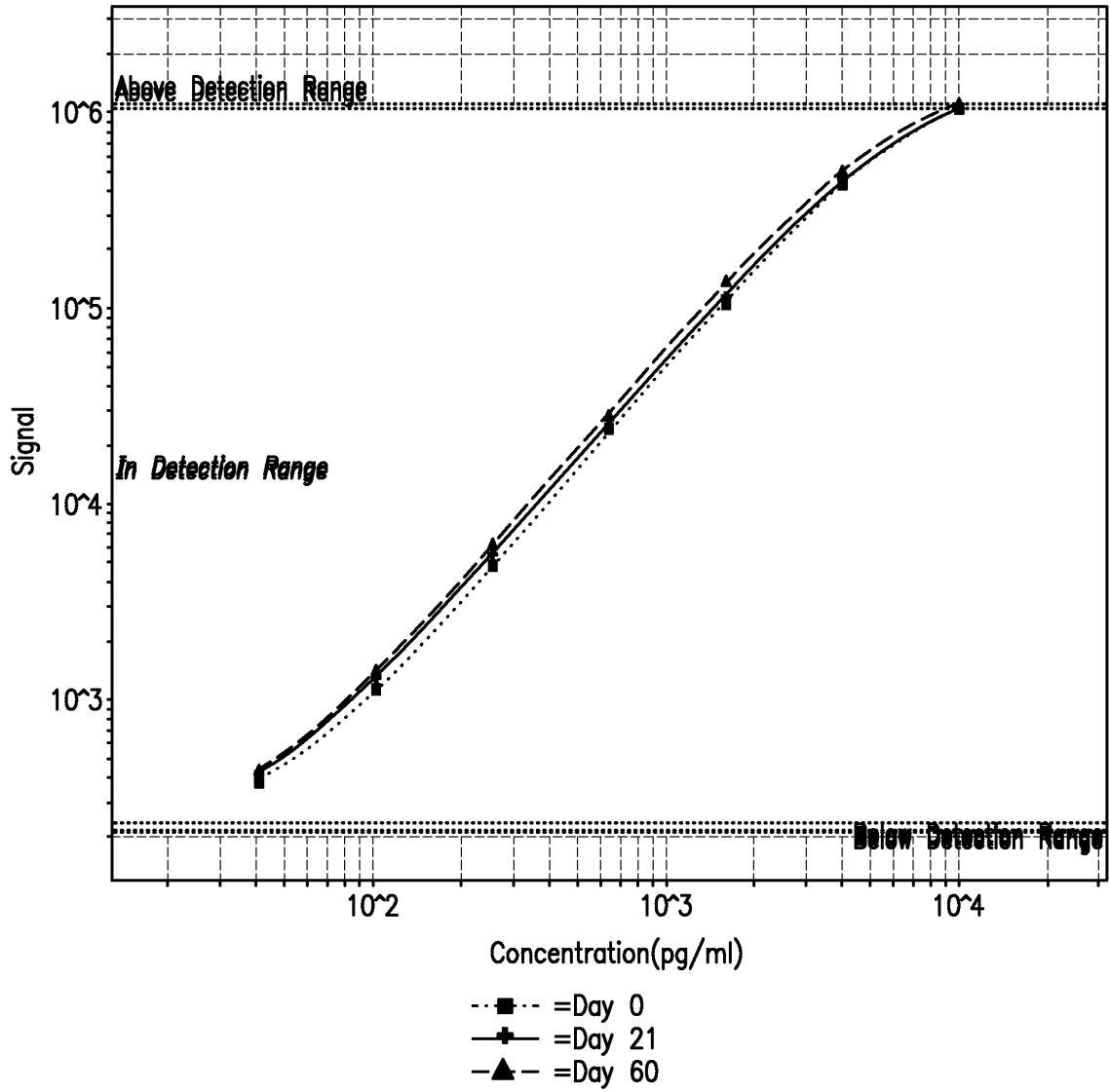

FIG. 10F

GS#5 at 37 C

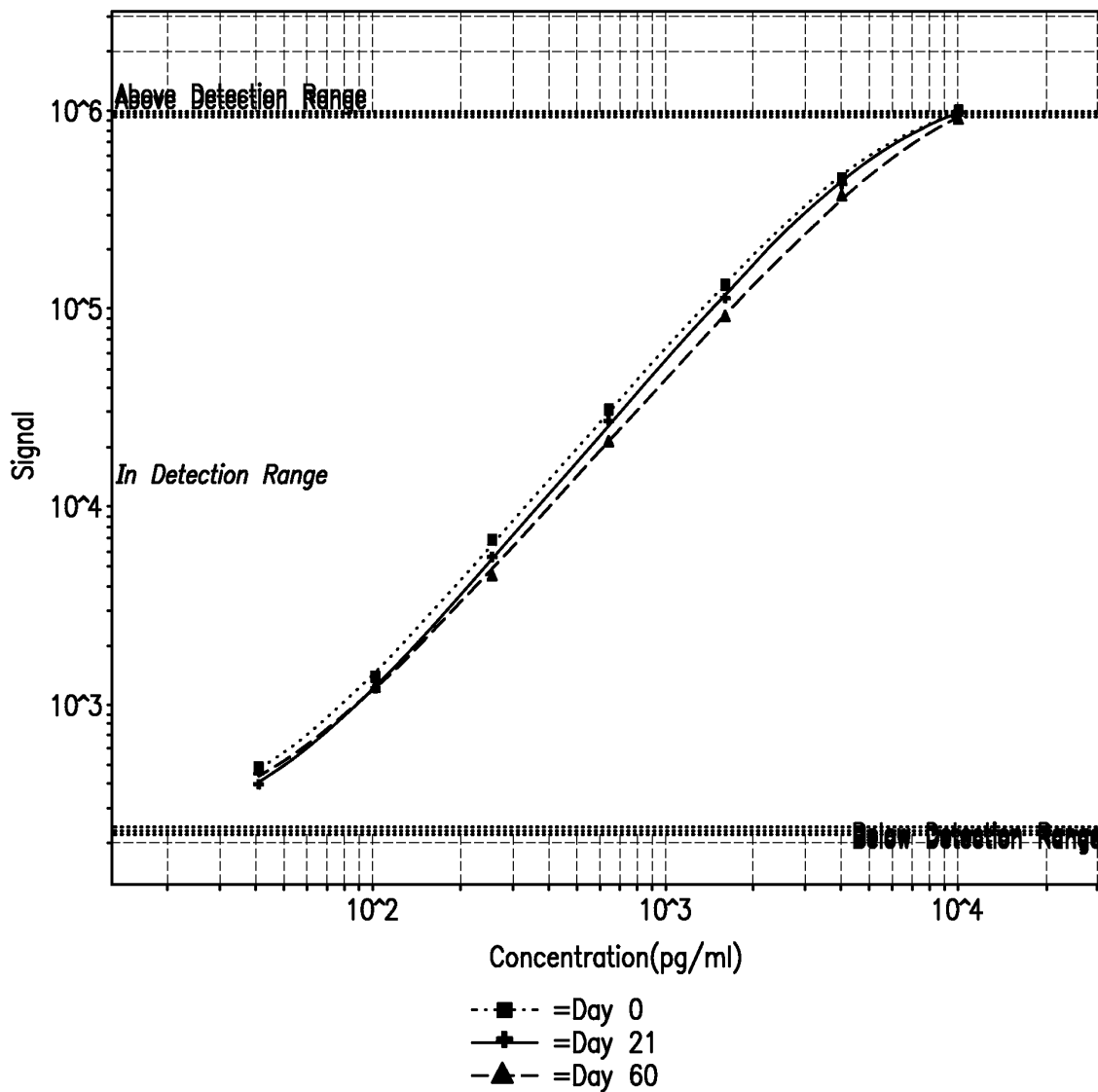

FIG. 10G

GS#6 at 37 C

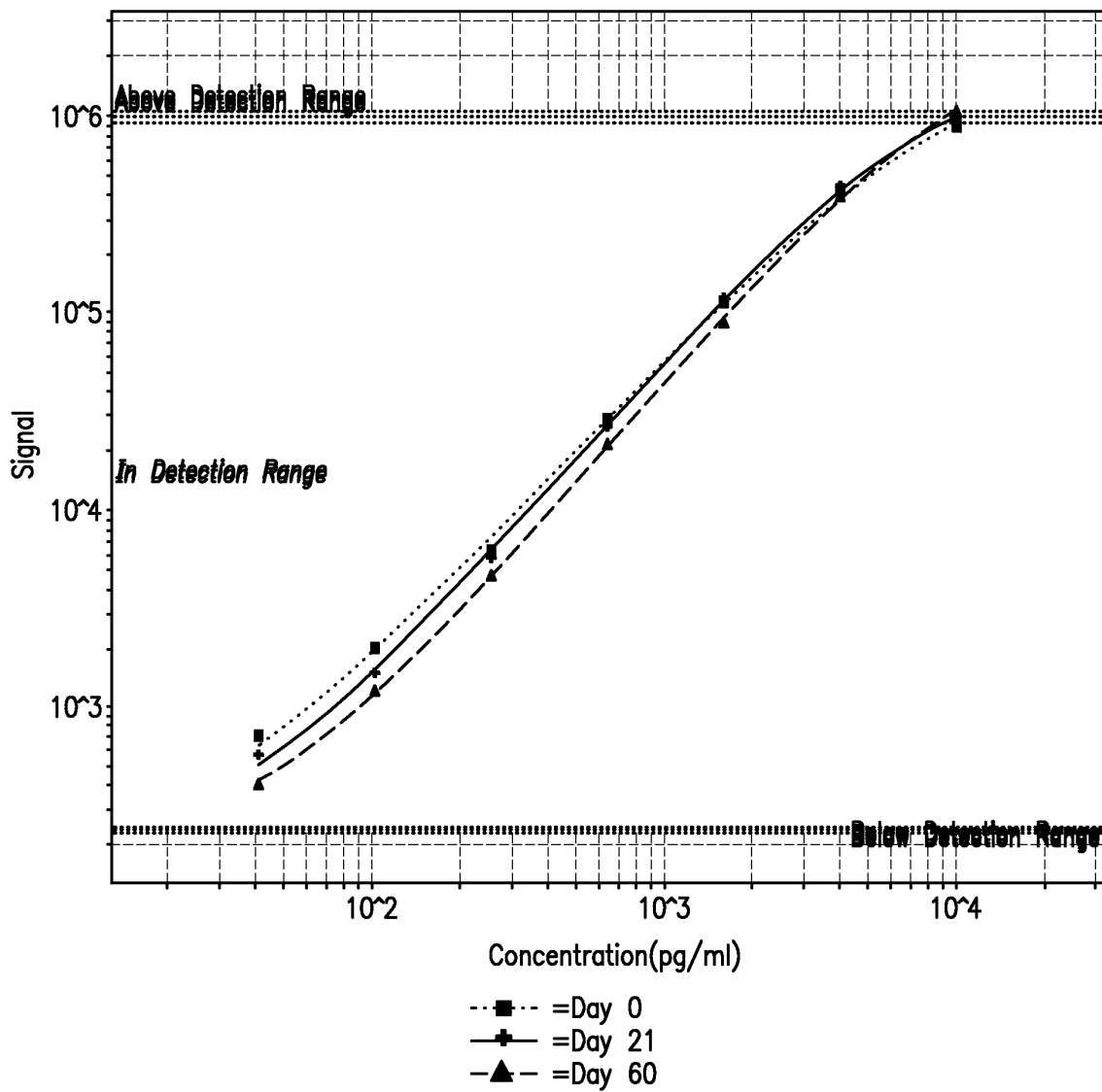

FIG. 10H

AN-7 at 37 C

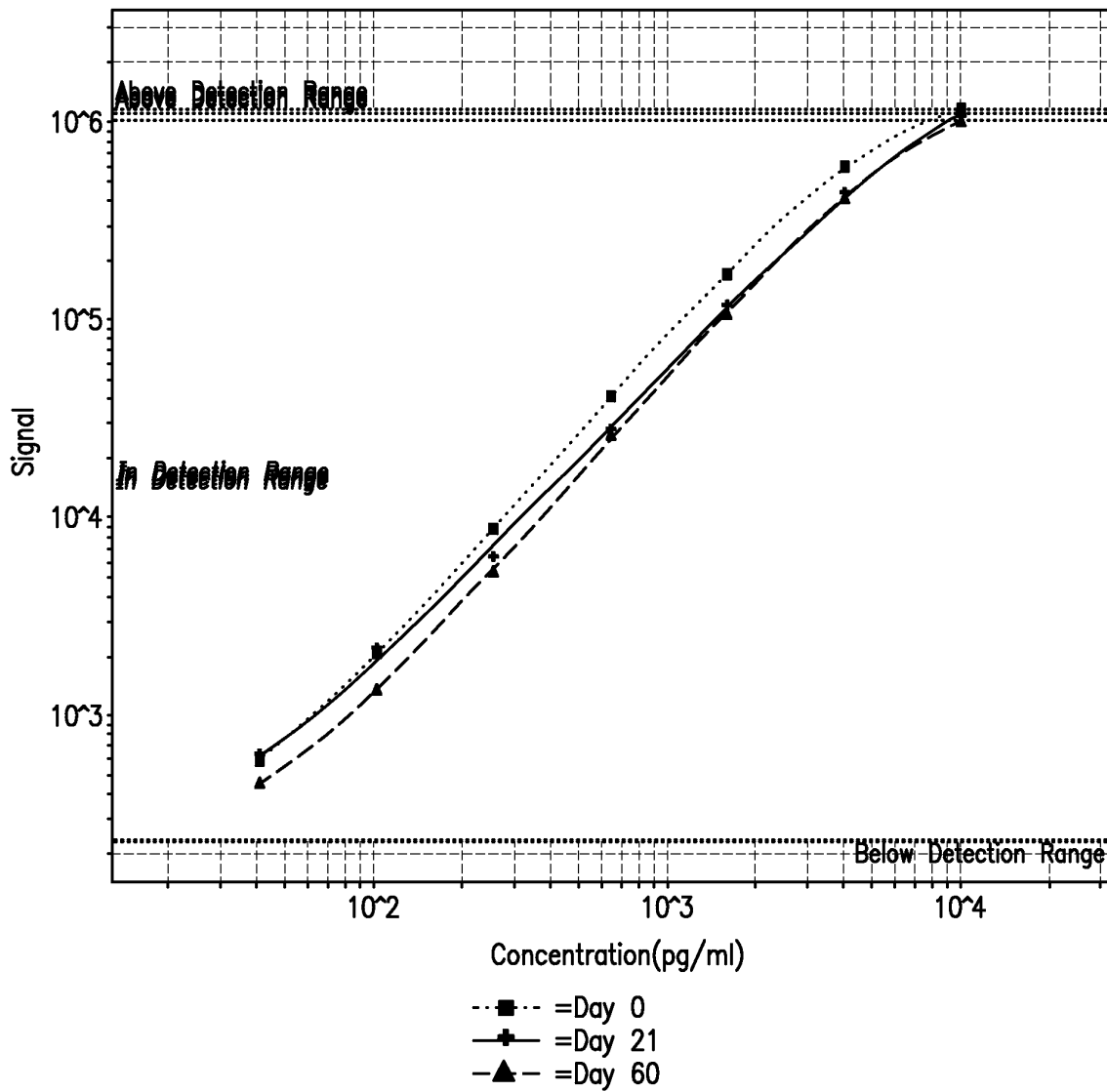

FIG. 10I

Plot_20101129140314

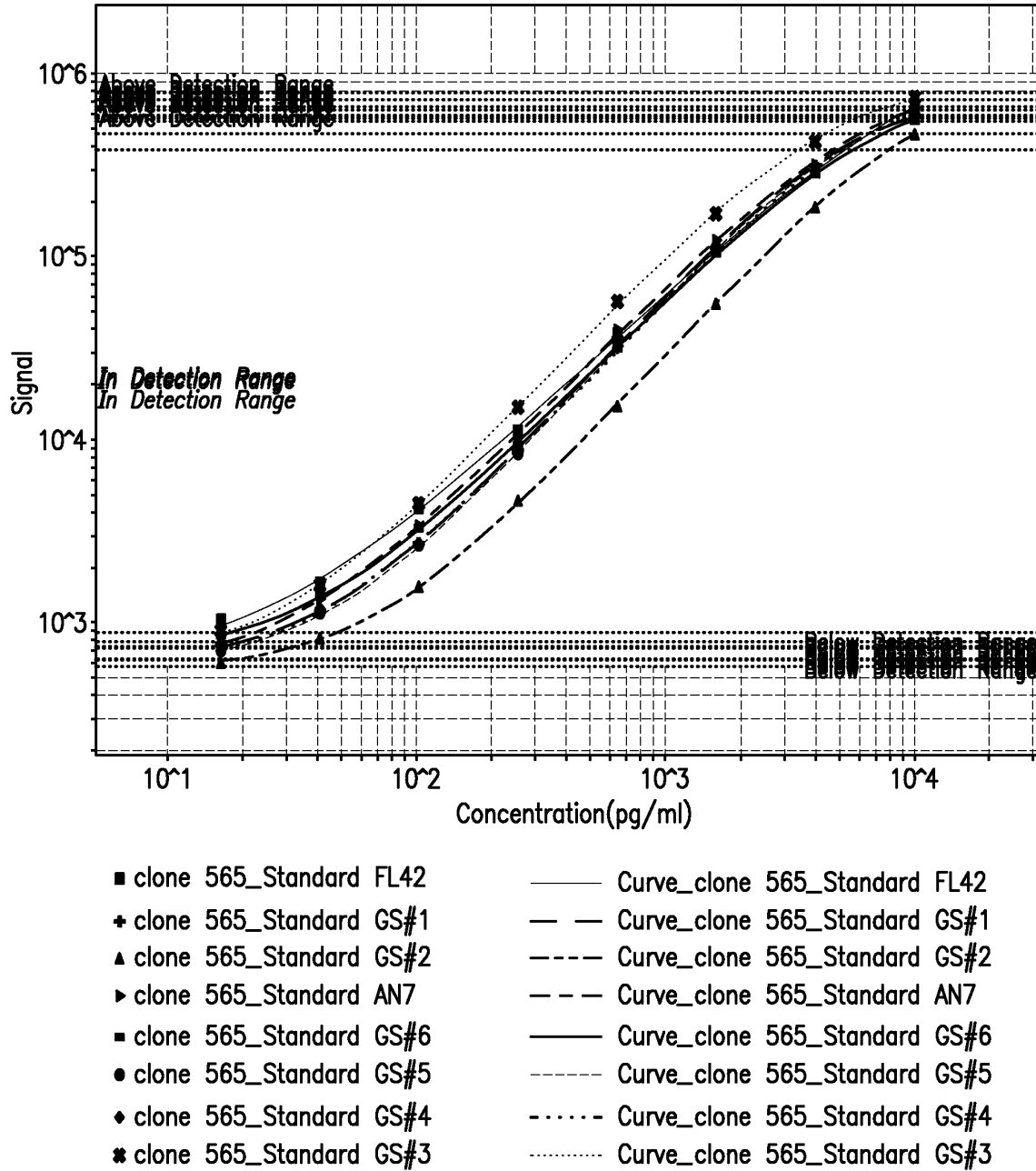

FIG. 11

Back Calculated Abeta42 Values

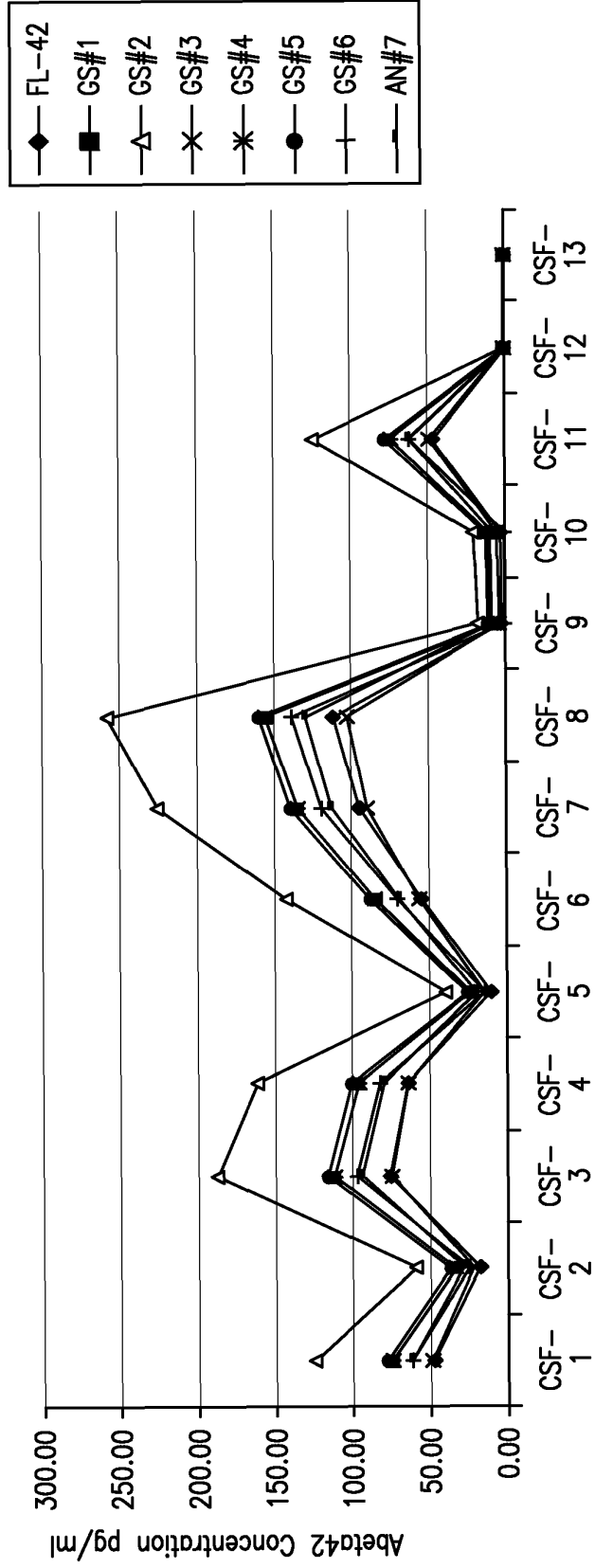
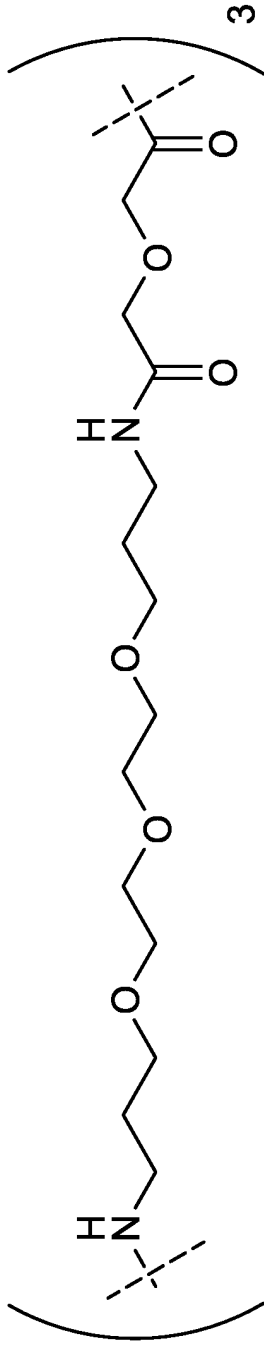
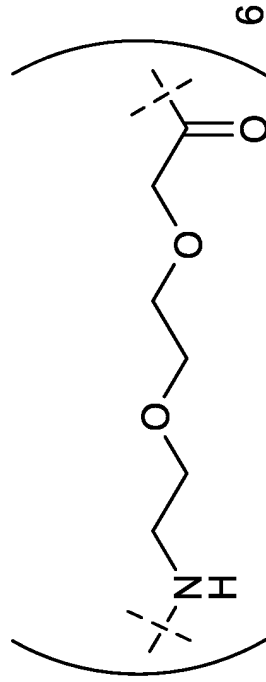

FIG. 12



PEG(20-ATOMS)₃



PEG(9-ATOMS)₆

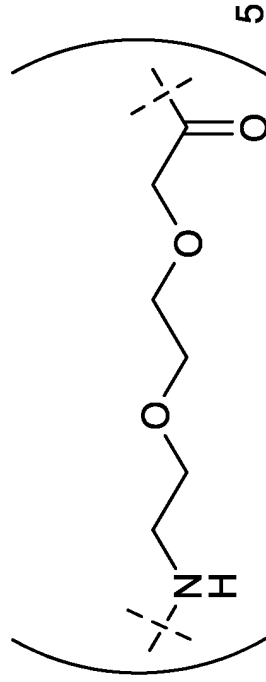

PEG(9-ATOMS)₅

FIG. 13

REFERENCES CITED IN THE DESCRIPTION

This list of references cited by the applicant is for the reader's convenience only. It does not form part of the European patent document. Even though great care has been taken in compiling the references, errors or omissions cannot be excluded and the EPO disclaims all liability in this regard.

Patent documents cited in the description

- WO 2007090126 A [0008]
- US 20020182660 A [0008]

Non-patent literature cited in the description

- **WOLFE.** *Biochemistry*, 2006, vol. 45, 7931-7939 [0002]
- **HARDY et al.** *Science*, 1992, vol. 256, 184-185 [0002]
- **BURDICK et al.** *Journal of Biological Chemistry*, 1992, vol. 267, 546-554 [0003]
- **CERF et al.** *Biochemical Journal*, 2009, vol. 421, 415-423 [0003]
- **TJERNBERG et al.** *Journal of Biological Chemistry*, 1996, vol. 271, 8545-8548 [0003] [0004]
- **KIM et al.** *Journal of Biological Chemistry*, 2005, vol. 280, 35069-35076 [0003]
- **MARTHARU et al.** *Journal of Neurological Sciences*, 2009, vol. 280, 49-58 [0004]
- **KIM et al.** *Biochemical and Biophysical Research Communications*, 2003, vol. 303, 576-279 [0004]
- **TJERNBERG et al.** *Journal of Biological Chemistry*, 1999, vol. 274, 12619-12625 [0004]
- **OLSSON et al.** *Clinical Chemistry*, 2005, vol. 51, 336-345 [0005] [0052]
- **VERWEY et al.** *Journal of Immunological Methods*, 2009, vol. 348, 57-66 [0005]
- **SJOGREN et al.** *Journal of Neural Transmission*, 2000, vol. 107, 563-679 [0005]
- **CANTONE et al.** *Journal of Neuroscience Methods*, 2009, vol. 180, 255-260 [0005]
- *Journal of Mass Spectrometry*, 2005, vol. 40, 142-145 [0005]
- **WURTH et al.** *J Mol Biol*, 2002, vol. 319, 1279-90 [0008]
- **LIAO et al.** *FEBS Letters*, 2007, vol. 581, 1161-65 [0008]
- **KANU et al.** *Journal of Mass Spectrometry*, 2008, vol. 43, 1-22 [0051]
- **BERNSTEIN et al.** *Journal of American Chemical Society*, 2005, vol. 127, 2075-2084 [0051]
- **LI et al.** *Encyclopedia of Analytical Chemistry*. John Wiley & Sons Ltd, 2009 [0051]
- *Analy. Biochem.*, 2003, vol. 316, 223-231 [0052]
- *Meth. Enzymology*, 1999, vol. 309, 429-459 [0052]
- *J. Biol. Chem.*, 1999, vol. 274, 25945-25952 [0052]
- *PNAS*, 2003, vol. 100, 330-335 [0052]
- *Meth. Enzymology*, 1999, vol. 309, 274-284 [0052]
- *Protein Pep. Letters*, 2006, vol. 13, 261-270 [0052]
- *J. Am. Chem. Soc.*, 2003, vol. 125, 15359-15365 [0052]
- **VERWEY et al.** *Journal of Immunological Methods*, 2009, vol. 348, 57-66 [0052]
- **BARANY, G. et al.** *The Peptides: Analysis, Synthesis, Biology - Special Methods in Peptide Synthesis*. Academic Press, 1980, vol. 2, 3-284 [0078]
- **STEWART, J.M. et al.** *Solid-Phase Peptide Synthesis*. Pierce Chemical Co, 1984 [0078]
- **ANDERSON et al.** *Clinical Chemistry*, 1991, vol. 37 (3), 398-402 [0086]

专利名称(译)	使用批内校准标准的免疫测定标准和临床生物标志物的测量		
公开(公告)号	EP2534490B1	公开(公告)日	2015-12-16
申请号	EP2011704514	申请日	2011-02-09
[标]申请(专利权)人(译)	百时美施贵宝公司		
申请(专利权)人(译)	施贵宝公司		
当前申请(专利权)人(译)	施贵宝公司		
[标]发明人	RHYNE PAUL MAPELLI CLAUDIO WONG OITAK BERISHA FLORA NEELY ROBERT JOHN		
发明人	RHYNE, PAUL MAPELLI, CLAUDIO WONG, OITAK BERISHA, FLORA NEELY, ROBERT JOHN		
IPC分类号	G01N33/68 G01N33/531 C07K19/00		
CPC分类号	G01N33/531 G01N33/6896 C07K14/4711 C07K16/28 G01N33/54393 G01N2333/4709 G01N2496/00		
优先权	61/302835 2010-02-09 US		
其他公开文献	EP2534490A1		
外部链接	Espacenet		

摘要(译)

本发明提供了创建定量标准以校准分析物的新型组合物和方法。这些组合物和方法能够产生用于分析分析物和测量临床生物标志物的标准物和校准物。还提供了包含用于测定法，例如夹心免疫测定法的新型组合物的试剂盒。

DAEFRHDSGYEVHHQKLVFFAEDVGSNKGAI

GLMVGGVVIA (SEQ ID NO:1)