

(19)



Europäisches Patentamt  
European Patent Office  
Office européen des brevets



(11)

**EP 1 060 747 A2**

(12)

**EUROPEAN PATENT APPLICATION**

(43) Date of publication:  
**20.12.2000 Bulletin 2000/51**

(51) Int. Cl.<sup>7</sup>: **A61K 38/48**, C12Q 1/56,  
G01N 33/53, A61K 48/00,  
A61P 7/02  
// (A61K38/48, 38:49)

(21) Application number: **00202122.8**

(22) Date of filing: **16.06.2000**

(84) Designated Contracting States:  
**AT BE CH CY DE DK ES FI FR GB GR IE IT LI LU  
MC NL PT SE**  
Designated Extension States:  
**AL LT LV MK RO SI**

(72) Inventor: **Bini, Alessandra  
New York, NY 10021 (US)**

(30) Priority: **16.06.1999 US 334090**

(74) Representative:  
**Prins, Adrianus Willem et al  
Vereenigde,  
Nieuwe Parklaan 97  
2587 BN Den Haag (NL)**

(71) Applicant:  
**New York Blood Center, Inc.  
New York, NY 10021 (US)**

(54) **Fibrin(ogen) degradation and clot lysis by fibrinolytic metalloproteinase**

(57) The invention provides a method of causing the degradation of fibrin(ogen) (i.e., fibrin, fibrinogen, and related substances) by means of a fibrinolytic matrix metalloproteinase, preferably an MT1-MMP. The method of the invention can be performed *in vitro* to provide diagnostic information characterizing fibrin(ogen) and fibrinolytic physiology. The method can also be performed *in vivo* as a method of thrombolytic therapy in which a fibrinolytic matrix metalloproteinase is administered to a subject to degrade thrombus *in situ*. The fibrinolytic matrix metalloproteinase can be administered in conjunction with other active agents, preferably with agents having thrombolytic activity to improve thrombolytic and fibrinolytic therapy. The invention further provides compositions containing a fibrinolytic matrix metalloproteinase for the performance of fibrinolytic or thrombolytic procedures. Also provided are kits that include a fibrinolytic matrix metalloproteinase for performing fibrinolytic or thrombolytic procedures.

**EP 1 060 747 A2**

**Description****BACKGROUND OF THE INVENTION**

5 [0001] This invention relates to a method of enzyme-mediated breakdown of fibrinogen and fibrin. More particularly, the invention relates to a method for degrading fibrinogen and causing lysis of fibrin clots through mediation by a fibrinolytic matrix metalloproteinase. The invention further relates to the use of a fibrinolytic matrix metalloproteinase as an antithrombotic to reconstruct stenotic vessels and remove fibrin deposits.

10 [0002] The clotting of blood is part of the body's natural response to injury or trauma. Blood clot formation derives from a series of events called the coagulation cascade, in which the final steps involve the formation of the enzyme thrombin. Thrombin converts circulating fibrinogen into fibrin, a mesh-like structure that forms the insoluble framework of the blood clot. As a part of hemostasis, clot formation is often a life-saving process in response to trauma and serves to arrest the flow of blood from severed vasculature.

15 [0003] The life-saving process of clot production in response to an injury can become life-threatening when it occurs at inappropriate places in the body. For example, a clot can obstruct a blood vessel and stop the supply of blood to an organ or other body part. In addition, the deposition of fibrin contributes to partial or complete stenosis of blood vessels, resulting in chronic diminution of blood flow. Equally life-threatening are clots that become detached from their original sites and flow through the circulatory system causing blockages at remote sites. Such clots are known as embolisms. Indeed, pathologies of blood coagulation, such as heart attacks, strokes, and the like, have been estimated  
20 to account for approximately fifty percent of all hospital deaths.

[0004] The formation of fibrin during inflammation, tissue repair, or hemostasis, plays only a temporary role and must be removed when normal tissue structure and function is restored. Thus, a fibrin clot that forms quickly to stop hemorrhage in an injured blood vessel is remodeled and then removed to restore normal blood flow as healing occurs. The system responsible for fibrin breakdown and clot removal is the fibrinolytic system. Action of the fibrinolytic system  
25 is tightly coordinated through the interaction of activators, zymogens, enzymes, as well as through inhibitors of each of these components, to provide focused local activation at sites of fibrin deposition (Francis et al. 1994; Collen 1980; Collen et al. 1991).

[0005] The principal mediator of fibrinolysis is plasmin, a trypsin-like endopeptidase that cleaves fibrin to dissolve clots and to permit injured tissues to regenerate. Plasmin has also been demonstrated to play a role in degrading proteins involved in cell-cell and cell-matrix interactions, as well as in activating other tissue remodeling enzymes such as matrix metalloproteinases (Murphy et al. 1992). In turn, control of plasmin activity, as well as these other extracellular events, is principally mediated by plasminogen activators, which convert the inactive zymogen plasminogen to the active enzyme plasmin.  
30

[0006] In clinical settings, it is commonly desirable to activate or potentiate the fibrinolytic system. This is particularly necessary in cases of myocardial infarction in which coronary arteries become occluded and require recanalization. Catheterization has proven somewhat effective in such recanalization, but pharmacologic agents are desired to supplement or replace such invasive procedures to inhibit reocclusion. The study of the intricate system of thrombolysis and fibrinolysis has been a rapidly growing field, which has resulted in the development of a new generation of thrombolytic agents.  
35

[0007] Previous therapeutic treatments for dissolving life-threatening clots have included injecting into the blood system various enzymes that are known to break down fibrin (Collen 1996). The problems with these treatments has been that the enzymes were not site-specific, and, therefore, would do more than just cause dissolution of the clot. In addition, these enzymes interfere with and destroy many vital protein interactions that serve to keep the body from bleeding excessively due to the many minor injuries it receives on a daily basis. Destruction of these safeguards by such enzymes can lead to serious hemorrhage and other potentially fatal complications.  
40

[0008] Currently, the best known therapeutic agents for inducing or enhancing thrombolysis are compounds that cause the activation of plasminogen, the so-called "plasminogen activators" (Brakman et al. 1992). These compounds cause the hydrolysis of the arg560-val561 peptide bond in plasminogen. This hydrolysis yields the active two-chain serine protease, plasmin. A number of such plasminogen activators are known, including serine proteases such as urokinase plasminogen activator (u-PA), tissue-type plasminogen activator (t-PA), streptokinase (a non-enzyme protein) and staphylokinase. Of these, streptokinase is the most widely used therapeutic thrombolytic agent. However, while streptokinase and the other plasminogen activators have proven helpful in recanalization of coronary arteries, their ability to improve mortality is not devoid of side effects and their use still requires stringent control conditions to achieve success in a high percentage of cases (Martin et al. 1994). In addition, the use of such compounds can cause bleeding complications in susceptible individuals. On the other hand, one of the drawbacks of the use of t-PA in clinical trials has been the early reformation of the clot after it has been dissolved, resulting in thrombotic reocclusion in some patients.  
45  
50  
55

[0009] Numerous studies have documented the ability of t-PA to initiate or potentiate thrombolytic phenomena (Sobel et al. 1987). As a result, t-PA, specifically its recombinant form, rt-PA, is becoming more popular as a thrombo-

lytic pharmaceutical. Nonetheless, rt-PA does suffer from serious limitations, including extremely high dosage cost, and variable efficacy. In addition, specific rapid-acting inhibitors of t-PA have been identified in human plasma and other fluids (Collen et al. 1987). A further approach to t-PA involves the potential use of gene transfer of and expression of recombinant t-PA in endothelial cells (Lee et al. 1993). This procedure is exceedingly complex and is not likely to be practical as a thrombolytic treatment in the near future.

**[0010]** Enzymes other than plasmin are also known that can degrade fibrin(ogen) to different extents. For example, endogenous leukocyte proteases (Bilezikian et al. 1977; Plow et al. 1975), later identified as elastase and cathepsin-G (Gramse et al. 1978; Plow 1980; Plow et al. 1982), can partially degrade fibrin(ogen). Other enzymes are also known that degrade fibrin. Such enzymes include hemolytic enzymes collected from the venom of certain snakes, e.g., the families crotalidae and viperidae (Purves et al. 1987; Retzios et al. 1992; Sanchez et al. 1991). Fibrinolytic enzymes isolated from snakes can be grouped into two different classes (Guan et al. 1991). Those enzymes that preferentially degrade the A $\alpha$ -chain of fibrinogen and also the  $\alpha$ - and  $\beta$ -chains of fibrin are zinc metalloproteases (Guan et al. 1991) and all can be inhibited by EDTA. Enzymes in the second class are serine proteinases, and exhibit specificity for the  $\beta$ -chain of fibrin (Guan et al. 1991). An endopeptidase from puff adder venom (*Bitis arietans*) can cleave at the  $\gamma$ -chain cross-linking site and thereby cleave Fragment D-dimer into a D-like monomer (Purves et al. 1987). Fibrinolytic enzymes have also been obtained from leeches (Zavalova et al. 1993; Budzynski 1991), as well as from the growth medium of a bacterium (*Aeromonas hydrophila*) that was recovered from leech intestinal tract (Loewy et al. 1993).

**[0011]** The matrix metalloproteinases ("MMPs" or "matrixins") are a class of enzymes that are expressed within the connective tissues of vertebrates. The MMPs occur natively in such tissues and play critical roles in the continuous processes associated with the laying down and remodeling of the extracellular matrix (ECM), hence their name: "matrix" metalloproteinases. The MMPs can be characterized as "intrinsic" or "endogenous" enzymes insofar as their proper function is within the tissues of the organism in which they are natively expressed. As such the MMPs are distinguished functionally and evolutionarily from the metalloproteinases found in snake venom and the like, which function outside the organism in which they are expressed, and may therefore be designated "exogenous" enzymes.

**[0012]** The matrix metalloproteinases are presently divided into six classes of enzymes: collagenases, gelatinases, stromelysins, matrilysin (formerly PUMP), metalloelastase, and membrane-type metalloproteinase. The membrane-type metalloproteinase class of MMP includes membrane-type 1 MMP (MT1-MMP), membrane-type 2 (MT2-MMP), membrane-type 3 (MT3-MMP), membrane-type 4 (MT4-MMP) (or MMPs 14-17). The collagenase class of MMPs includes interstitial collagenase (MMP-1), neutrophil collagenase (MMP-8), and collagenase-3 (MMP-13). The gelatinase class of MMPs includes gelatinase-A (MMP-2) and gelatinase-B (MMP-9). The stromelysin class of MMPs includes stromelysin-1 (MMP-3), stromelysin-2 (MMP-10), and stromelysin-3 (MMP-11). The matrilysin class of MMPs includes matrilysin (MMP-7). The metalloelastase class of MMPs includes metalloelastase (MMP-12). For recent reviews see Sato H. et al., "Membrane-Type Matrix Metalloproteinases (MT-MMPs) in Cell Invasion", *Thromb Haemost* 78, 497-500, 1997, and Nagase (1996).

**[0013]** MMPs are known to proteolytically cleave and degrade a number of proteins and proteoglycans that are associated with the extracellular matrix (ECM) of connective tissue. They have been shown to break down a number of proteins including collagen (Types I-IV, VII and X), laminin, fibronectin, elastin and proteoglycans. MMPs have also been identified in leukocytes (Welgus et al. 1990). It has been shown that MMP-2 and MMP-9 possess elastase activity (Senior et al. 1991), to which some of the complex proteolytic activity, initially observed in granulocytes, could be attributed (Sterrenberg et al. 1983). In addition, MMP-12 has also been shown to possess elastin activity (Nagase 1996). MMP-7 has been shown to possess strong proteolytic activity and digests aggrecan, cartilage link protein, fibronectin, and elastin (Nagase 1996). MMPs participate in the remodeling of tissues in physiological processes such as morphogenesis and embryonic development, as well as in the pathophysiology of wound healing, tumor invasion, and arthritis (Matrisian 1992; Nagase et al. 1991; Woessner 1991; Werb et al. 1992).

**[0014]** The expression of MMPs and their inhibitors is under extensive and varied molecular and cellular control (Kleiner et al. 1993; Matrisian 1992; Woessner 1991). Known regulating factors include hormones, cytokines, proto-oncogenes, steroids, and growth factors. MMPs are blocked by specific inhibitors called "tissue inhibitors of metalloproteinases" (TIMPs) that can block the activity of each member of the family. An enzyme inhibitor complex is formed and no turnover of connective tissue takes place if the MMPs are present in excess. The main focus of research on ECM has been to limit ECM degradation by MMPs to interrupt or interfere with the progression of disease states. Several groups of investigators are making small molecules that could inhibit proteinases to alter their destructive activity in arthritis, and as antiangiogenic factors to inhibit tumor spread.

**[0015]** Matrix metalloproteinase 3 (MMP-3) belongs to the stromelysin class of matrix metalloproteinases. MMP-3 is not only expressed in mature macrophages (Campbell et al. 1991), but is also in endothelial cells, smooth muscle cells and fibroblasts. More recently, MMP-3 has been shown to be expressed in macrophage-derived foam cells from experimental atheroma (Galis et al. 1995). The inactive zymogen, proMMP-3, is activated by neutrophil elastase, plasma kallikrein, plasmin, chymotrypsin, trypsin, cathepsin G, and mast cell tryptase, as well as by mercurial compounds, such as 4-aminophenylmercuric acetate (APMA) (Nagase et al. 1992; Kleiner et al. 1993; Nagase et al. 1990;

Nagase 1991). Elevated levels of MMP-3 have been found in the joints of patients suffering from osteoarthritis and rheumatoid arthritis. In atherosclerotic plaques, there is a large amount of fibrin(ogen)-related antigen (FRA) consisting of different molecular forms (Bini et al. 1987; Bini et al. 1989; Smith et al. 1990; Valenzuela et al. 1992). Two very recent studies have shown the presence of matrix metalloproteinase 3 in atherosclerotic plaques (Henney et al. 1991; Galis et al. 1994). The known substrates of MMP-3 include proteoglycans, collagen type IV, fibronectin, and laminin.

**[0016]** Membrane-type 1 matrix metalloproteinase (MT1-MMP) belongs to the membrane-type matrix metalloproteinase class of MMP. The membrane-type matrix metalloproteinases are a subclass of the matrix metalloproteinase family which uniquely possess a C-terminal transmembrane domain and are initiators of an activation cascade for progelatinase A. Recent studies have shown that they can also efficiently directly degrade a number of matrix macromolecules. Specifically, the expression of MT1-MMP on the cell surface may lead to both progelatinase A activation and extracellular matrix degradation. For recent review, see D'Ortho et al. 1998. MT1-MMP is expressed in various tissues. MT1-MMP mRNA expression is predominantly expressed in lungs, kidneys, and placenta where extracellular matrix remodeling is relatively active, and is lowest in the brain. MT1-MMP is expressed at a very high level in ossifying tissues during embryogenesis where gelatinases is co-expressed. MT1-MMP expression is elevated in various tumor tissues including lung, gastric, colon, and breast cancers, in which activated gelatinase A is expressed. See Sato et al. 1997. MT1-MMP also exhibits broad-spectrum proteolytic capacities comparable to many matrix metalloproteinases (D'Ortho et al. 1997).

**[0017]** It has been shown that MT1-MMP can degrade a number of substrates in extracellular. There has been no suggestion, however, that any membrane-type matrix metalloproteinases might be involved in the degradation of crosslinked fibrin. Nor has there been any indication that membrane-type matrix metalloproteinases could be used for fibrinolysis or thrombolysis.

**[0018]** From the foregoing discussion, it becomes clear that significant gaps exist in the understanding of processes involved in thrombus formation and degradation. While certain approaches have been identified that permit a measure of control over these processes, these approaches suffer serious deficiencies related to cost, efficacy, or safety. The diagnosis and treatment of disease states associated with physiological processes involving fibrinogen and fibrin have also been found lacking.

**[0019]** As a result, there exists a need for effective compositions and methods for use in limiting thrombus development and inducing thrombolysis.

**[0020]** There is a need for methods of disrupting blood clots and atherosclerotic plaques, both *in vitro*, such as for diagnostic purposes, and *in vivo*, such as for therapeutic treatment of embolism, atherosclerosis and other clinically important disorders.

**[0021]** In addition, there exists a need for diagnostic and experimental materials and methods for revealing more information concerning the physical and chemical processes involved in thrombus formation and degradation.

**[0022]** Moreover, there is a need for effective treatment to restore at least some integrity to a damaged vessel wall, to promote regression of atherosclerotic plaques, and to aid in angioplasty and bypass surgery to prevent reocclusion.

## SUMMARY OF THE INVENTION

**[0023]** In one embodiment, the invention is a method of degrading fibrin(ogen), comprising contacting fibrin(ogen) with an amount of a fibrinolytic matrix metalloproteinase (MMP) effective for cleaving the fibrin(ogen).

**[0024]** The fibrinolytic matrix metalloproteinase useful according to the invention is selected from the group consisting of interstitial collagenase (MMP-1), neutrophil collagenase (MMP-8), collagenase-3 (MMP-13), gelatinase-A (MMP-2), stromelysin-1 (MMP-3), stromelysin-2 (MMP-10), stromelysin-3 (MMP-11), matrilysin (MMP-7), metalloelastase (MMP-12), and membrane-type metalloproteinase MT 1-4 MMPs (or MMPs 14-17). The fibrinolytic matrix metalloproteinase can be a mammalian, preferably a primate, and more preferably a human matrix metalloproteinase. The fibrinolytic matrix metalloproteinase is preferably a membrane-type metalloproteinase more preferably, MT1-MMP.

**[0025]** The method can further comprise contacting the fibrin(ogen) with an effective amount of at least one adjuvant compound having thrombolytic activity. The at least one adjuvant compound having thrombolytic activity can be selected from the group consisting of plasminogen activators, hirudin, enzyme inhibitors, enzymes, anticoagulants, antibodies, and synthetic peptides specific for platelet GP IIb/IIIa receptor. Preferred plasminogen activators are selected from the group consisting of urokinase plasminogen activator (u-PA), tissue-type plasminogen activator (t-PA), streptokinase, and staphylokinase.

**[0026]** The method can be performed *in vivo*, or can be performed in systems in which the fibrin(ogen) comprises substantially purified fibrin or fibrinogen. Alternatively, the fibrin(ogen) can be present in the form of a thrombus or an atherosclerotic plaque.

**[0027]** In another embodiment, the invention is a method of fibrinolytic therapy, comprising administering to a subject in need of fibrinolytic therapy a therapeutically effective amount of a fibrinolytic matrix metalloproteinase.

**[0028]** The fibrinolytic matrix metalloproteinase useful according to the invention is selected from the group consist-

ing of interstitial collagenase (MMP-1), neutrophil collagenase (MMP-8), collagenase-3 (MMP-13), gelatinase-A (MMP-2), stromelysin-1 (MMP-3), stromelysin-2 (MMP-10), stromelysin-3 (MMP-11), matrilysin (MMP-7), metalloelastase (MMP-12), and membrane-type metalloproteinase MT1-4 MMPs (or MMPs 14-17). The fibrinolytic matrix metalloproteinase can be a mammalian, preferably a primate, and more preferably a human matrix metalloproteinase. The fibrinolytic matrix metalloproteinase is preferably a membrane-type metalloproteinase more preferably, MT1-MMP.

**[0029]** The method can further comprise contacting the fibrin(ogen) with an effective amount of at least one adjuvant compound having thrombolytic activity. The at least one adjuvant compound having thrombolytic activity can be selected from the group consisting of plasminogen activators, hirudin, enzyme inhibitors, enzymes, anticoagulants, antibodies, and synthetic peptides specific for platelet GP IIb/IIIa receptor. Preferred plasminogen activators are selected from the group consisting of urokinase plasminogen activator (u-PA), tissue-type plasminogen activator (t-PA), streptokinase, and staphylokinase.

**[0030]** The method can be performed following thrombolytic therapy to inhibit vascular reocclusion, following surgical intervention to inhibit restenosis, or to inhibit initial formation, or promote regression, of atherosclerotic plaques.

**[0031]** In another embodiment, the invention is a composition for thrombolytic therapy, comprising a fibrinolytic matrix metalloproteinase that cleaves fibrin(ogen), and a pharmaceutically acceptable carrier. The composition can accommodate any of the fibrinolytic matrix metalloproteinases described above, and can further include adjuvant agents also as described above.

**[0032]** In still another embodiment, the invention is a kit for performing thrombolytic therapy, comprising a composition comprising a fibrinolytic matrix metalloproteinase, and a container.

**[0033]** Consistent with the invention as described, the fibrinolytic matrix metalloproteinase is preferably MT1-MMP and the kit can further comprise at least one adjuvant compound having thrombolytic activity, such as those selected from the group consisting of plasminogen activators, hirudin, enzyme inhibitors, enzymes, anticoagulants, antibodies and synthetic peptides specific for platelet GP IIb/IIIa receptor.

**[0034]** Preferably, however, the kit according to the invention further comprising means for administering a therapeutically effective amount of the composition, such as means for administering the composition parenterally.

**[0035]** The invention is also, in another embodiment, a diagnostic method for characterizing fibrin(ogen), comprising contacting fibrin(ogen) with a fibrinolytic matrix metalloproteinase, e.g., MT1-MMP, to provide characteristic cleavage products of the fibrin(ogen).

**[0036]** The diagnostic method can further comprise contacting the cleavage products with at least one antibody that specifically binds with a domain of fibrin(ogen), and measuring specific binding of the antibody with the separated cleavage products. The antibody is preferably detectably labeled with a detectable marker moiety. Preferred antibodies include monoclonal antibodies, synthetic antibodies, chimeric antibodies, Fab antigen binding regions, or F(ab')<sub>2</sub> antigen binding regions.

**[0037]** Also, in another embodiment, the invention is a method of inhibiting thrombus formation by a medical-related apparatus, comprising contacting a medical-related apparatus with a composition comprising a fibrinolytic matrix metalloproteinase to provide a thrombus-inhibiting surface on the medical-related apparatus. The medical-related apparatus can be selected from the group consisting of blood collection tubes, culture flasks, test plates, pipets, reagent containers, tubing, membranes, needles, cannulae, catheters, grafts, stents, filters, coils, valves, and the like. The invention further includes the resulting medical-related apparatus having thrombus-inhibiting properties, comprising a medical-related device having provided thereto a thrombus-inhibiting amount of a composition comprising a fibrinolytic matrix metalloproteinase.

**[0038]** In another embodiment, the invention is further a method of enhancing regulation of fibrinolysis in a subject in need of such therapy, comprising inducing enhanced regulation of an endogenous fibrinolytic matrix metalloproteinase in a subject. Preferably, the inducing step comprises increasing the activity or expression of an endogenous fibrinolytic matrix metalloproteinase by treating the subject with somatic cell gene transfer therapy. Alternatively, the inducing step comprises decreasing the activity or expression of an endogenous fibrinolytic matrix metalloproteinase by treating the subject with somatic cell gene transfer therapy.

**[0039]** These and other advantages of the present invention will be appreciated from the detailed description and examples that are set forth herein. The detailed description and examples enhance the understanding of the invention, but are not intended to limit the scope of the invention.

## BRIEF DESCRIPTION OF THE DRAWINGS

**[0040]** Preferred embodiments of the invention have been chosen for purposes of illustration and description, but are not intended in any way to restrict the scope of the present invention. The preferred embodiments of certain aspects of the invention are shown in the accompanying drawings, wherein:

Figure 1 shows an electrophoretic analysis of fibrinogen treated with MMP-2 or MMP-3, showing differential degra-

5      dation of fibrinogen by each of the enzymes.

Figure 2A is a graph illustrating comparative fibrin clot lysis by MMPs and plasmin as measured by the percentage of radioactivity in the sample supernatants.

Figure 2B is a graph illustrating comparative fibrin clot lysis by MMPs and plasmin as measured by the percentage of radioactivity in the residual clots.

10      Figure 3 shows an electrophoretic analysis of fibrin treated with MMP-2, MMP-3, and plasmin, showing differential degradation of fibrinogen by each of the enzymes.

Figure 4A shows an immunoblot of the degradation products of fibrin digestion by MMP-3 and plasmin, as measured with MoAb/4-2 ( $\gamma$ 392-406).

15      Figure 4B shows an immunoblot of the degradation products of fibrin digestion by MMP-3 and plasmin, as measured with MoAb/4A5 ( $\gamma$ 397-411).

Figure 5 shows an immunoblot of the degradation products of fibrin digestion by MMP-3, as measured with MoAb/T2G1 (B $\beta$ 15-42) and MoAb/1D4 (A $\alpha$ 349-406).

20      Figure 6A shows an electrophoretic analysis (non-reducing conditions) of D-dimer treated with MMP-3, showing time- and concentration-dependent degradation of D-dimer by MMP-3.

25      Figure 6B shows an electrophoretic analysis (reducing conditions) of D-dimer treated with MMP-3, showing time- and concentration-dependent degradation of D-dimer by MMP-3.

Figure 7 is a schematic diagram illustrating the cross-linking region in cross-linked fibrin, showing cleavage sites of MMP-3 and CNBr.

30      Figure 8 shows an electrophoretic analysis of the products of degradation of fibrinogen and cross-linked fibrin by MMP-3.

Figure 9 shows a comparative electrophoretic analysis of the products of degradation of fibrinogen and cross-linked fibrin by MMP-7, MMP-3, and MMP-9.

35      Figure 10 shows a comparative electrophoretic analysis of the products of degradation of cross-linked fibrin  $\gamma$ -chain dimers by MMP-7 and MMP-3.

## 40      DETAILED DESCRIPTION OF THE INVENTION

**[0041]** As noted above, recent studies have identified MT1-MMP on the cell surface that causes focal degradation of gelatin films (D'Ortho et al. 1998). These studies have indicated that the expression of MT1-MMP on cell surface may lead to progelatinase A activation and extracellular matrix degradation. The present invention, however, is consistent with an entire understanding of the function of MT1-MMP. The invention relates to the unexpected role that MT1-MMP has been discovered to play in the degradation of fibrinogen and fibrin.

**[0042]** For purposes of more clearly and accurately describing the invention herein, certain terminological conventions have been adopted in the following discussion. These conventions are intended to provide a practical means for enhancing description of the invention, but are not intended to be limiting, and the skilled artisan will appreciate that other and additional, albeit not inconsistent, interpretations can be implied.

50      **[0043]** The invention relates to the use of a matrix metalloproteinase to proteolytically cleave and degrade fibrin and fibrinogen. The matrix metalloproteinases useful according to the invention must exhibit some enzymatic activity against fibrin, fibrinogen, or related proteins, polypeptides, or oligopeptides. Matrix metalloproteinases that exhibit this activity are termed "fibrinolytic matrix metalloproteinases" or "fibrinolytic MMPs." Matrix metalloproteinases that do not exhibit any significant activity against fibrin(ogen) are not fibrinolytic as defined herein, and are not within the scope of the invention. Enzymes that are not recognized as having matrix metalloproteinase activity, as that term is conventionally understood, are not within the invention.

55      **[0044]** The fibrinolytic matrix metalloproteinases useful according to the invention are preferably natively expressed in or is endogenous to a vertebrate species. The species can be any vertebrate, preferably a mammal, and more pref-

erably a primate. Most preferably, the MMP is of human origin.

**[0045]** Recombinant MMPs can also be used in the invention, provided that they exhibit significant fibrinolytic activity. In particular, the artisan can construct fusion or chimeric proteins comprising a fibrinolytic domain of a fibrinolytic MMP with a domain of another protein. Such fusion proteins can be constructed to achieve various ends, e.g., to protect a desired protein from proteolytic cleavage. Preferred fusion proteins can include a fibrinolytic domain of a matrix metalloproteinase with an active domain of another protein, e.g., an antigen binding region of an antibody, a ligand binding site of a receptor, or an active site of an enzyme such as thrombolytic enzyme, e.g., t-PA or recombinant or mutated forms thereof. Optionally, an enzymatic cleavage site can be incorporated into the fusion protein, to permit controlled cleavage to release one or more active components. Chemical cleavage can also be done. Such chimeric proteins containing a fibrinolytic domain of a matrix metalloproteinase are intended to be encompassed within the scope of the term "fibrinolytic matrix metalloproteinase" as it used herein.

**[0046]** Methods for manufacturing fusion proteins are known in the art, using conventional tools known to the artisan, such as are described in Sambrook et al. (1989). Methods, i.e., expression systems, exist for manufacturing genetic constructs for attaching a gene encoding a protein or a fragment thereof to another coding sequence, to yield a translated product that is a linear combination or concatenation of the two proteins. General description of such techniques is found in Glick et al. (1994) and San et al. (1995), with more specific description found in the documents cited therein.

**[0047]** When the method of the invention is employed *in vivo*, it is preferred that the fibrinolytic matrix metalloproteinase be endogenous to the species in which the method is performed, i.e, when the method is performed as thrombolytic therapy in a human, it is preferred to use a human MMP. This is the case regardless of whether the MMP is employed as an active in a pharmaceutical composition or is generated endogenously through therapy designed to improve the subject's internal control of his/her fibrinolytic system. For *in vitro* procedures, the origin of the matrix metalloproteinase is less critical, but it is preferred that the metalloproteinase have an origin as close as possible to the species origin of the biological sample being examined.

**[0048]** Fibrinolytic matrix metalloproteinases (MMPs) useful according to the invention can be selected from the fibrinolytic MMPs occurring in any of the six classes of enzymes: collagenases, gelatinases, stromelysins, matrilysins, metalloelastases, and membrane-type metalloproteinases. Examples of the fibrinolytic MMPs of the present invention include interstitial collagenase (MMP-1), neutrophil collagenase (MMP-8), and collagenase-3 (MMP-13), gelatinase-A (MMP-2), stromelysin-1 (MMP-3), stromelysin-2 (MMP-10), stromelysin-3 (MMP-11), matrilysin (MMP-7), metalloelastase (MMP-12), and membrane-type metalloproteinase MT1-4 MMPs (or MMPs 14-17). Preferred fibrinolytic MMPs include the membrane-type metalloproteinase, more preferably MT1-MMP.

**[0049]** It is known that, due to the fluidity and complexity of the physiology of fibrin formation and degradation, many forms of fibrin and fibrinogen are present in the circulating blood as well as in thrombotic and atherosclerotic lesions. The many forms of these molecules result from continual assault by proteolytic enzymes which variously cleave the molecules. The method of the invention is performed by means of a fibrinolytic MMP that has activity against at least one fibrinogen- or fibrin-related compound. If a fibrinogen-derived molecule has previously been cleaved or modified to delete all MMP cleavage sites, then that molecule is no longer capable of acting as a substrate for an MMP. Substrates for MMPs, notably MT1-MMP, have now unexpectedly been found to include, *inter alia*, native fibrinogen and cross-linked fibrin, and would also be expected to include modified, synthetic, and semisynthetic forms of these compounds, as well as a large number of cleavage or degradation products of these compounds. The class of substances that are derived from or related to fibrinogen and/or fibrin can be termed "fibrin(ogen)". The method of the invention can, therefore, be performed using any fibrinolytic MMP that acts to proteolytically cleave or degrade a fibrin(ogen) moiety.

**[0050]** Fibrinogen (also abbreviated herein as "Fg") is known to be a homodimeric protein, in which each monomer includes three substantially homologous polypeptide chains, identified as the  $\alpha$  (alpha),  $\beta$  (beta), and  $\gamma$  (gamma) chains. For a review see Doolittle (1987). Thus, fibrinogen has the structure  $(\alpha\beta\gamma)_2$ . All three fibrinogen subunits have coiled domains that permit the subunits to engage one another to form a "coiled coil" region in the fibrinogen monomer. In addition, the beta and gamma chains each have a globular domain, while the alpha chain is present in two forms; a predominant form having no corresponding globular domain ( $\alpha$ ), and a less prevalent form in which a globular domain is present ( $\alpha_E$ ) (Fu et al. 1994). Accordingly, because fibrinogen is homodimeric and because two forms of the alpha subunit have been identified, two principal forms of fibrinogen are known:  $(\alpha\beta\gamma)_2$  and  $(\alpha_E\beta\gamma)_2$ . Both forms of fibrinogen are considered to be substrates of MMPs according to the invention. Artificial heterodimers of fibrinogen, as well as recombinant forms are also within the class of MMP substrates.

**[0051]** As noted, fibrin (also abbreviated herein as "Fb") is generated through an induced and controlled polymerization of fibrinogen (Fu et al. 1994). Given that various forms of fibrinogen are known in circulating blood, it is known that various polymerization structures for fibrin occur. Fibrin structure can affect the processes of fibrinolysis (Gabriel et al. 1992). A fibrinolytic matrix metalloproteinase has now been found to effectively lyse fibrin. It appears, therefore, that matrix metalloproteinases are active against fibrin without being substantially limited by peculiarities of fibrin cross-linking. Accordingly, fibrin is considered to be an MMP substrate according to the invention. Thus, fibrin which occurs nat-

urally in a subject is suitable for degradation according to the invention, as is fibrin induced *in vitro*. Thus, clots which are induced in blood *ex vivo*, e.g., in a blood sample, can be degraded according to the invention. In such *in vitro* applications, a matrix metalloproteinase can be employed as a coating on a container such as blood collection tube. Also, artificial fibrin, formed from natural, synthetic, semisynthetic, recombinant and/or other types of fibrinogen can also be degraded by the method described herein.

**[0052]** Under physiologic conditions, plasmin is the central enzyme that acts to degrade fibrin. Plasmin action is restricted to the site of fibrin deposition by plasma control mechanisms that prevent proteolysis of circulating proteins. However, under pathologic conditions, plasmin is known to degrade plasma proteins, especially fibrinogen.

**[0053]** Degraded fibrinogen can be separated by ion-exchange chromatography into five fractions (A, B, C, D, and E), of which fragments D and E are the major end products of the original molecule. The identification and characterization of the transient intermediate fragments X and Y engendered the insight for the development of an asymmetric scheme of fibrinogen degradation (Francis et al. 1994).

**[0054]** Classically, fibrinogen structure is bilaterally symmetrical, including a central globular domain E that is a "knot" made up of the N-terminal regions of all six chains in the fibrinogen molecule. From E extend two coiled coils each of which contains portions of one set of  $\alpha$ ,  $\beta$ , and  $\gamma$  chains. At the other ends of the coiled coils are globular domains D. Extending from the D domains, are the  $A\alpha$  chain extensions, that, in the  $\alpha_E$  subunit only, terminate in another globular domain.

**[0055]** Under proteolytic attack by plasmin, initial cleavages liberate the carboxy-terminal, polar appendage of the  $A\alpha$  chain, and a peptide from the N-terminal portion of the  $B\beta$  chain ( $B\beta$ 1-42). The remaining major fragment is Fragment X. Cleavages of all three polypeptide chains along one coiled coil connecting the central N-terminal knot (E) and a terminal (D) domain of fragment X split it asymmetrically. The result is one fragment D molecule, that consists of carboxy-terminal portions of the three chains, and a fragment Y moiety, consisting of central and terminal domains still connected by a coiled coil. Subsequent cleavage of the coiled coil of fragment Y produces a second fragment D and a fragment E moiety. Fragment X is slowly coagulable by thrombin, but fragments Y and D have potent antipolymerizing effects, due mostly to disruption of the proper alignment and continuation of build-up of the protofibrils of fibrin.

**[0056]** Knowledge of the conventional fragmentation of fibrinogen assists in providing a conceptual framework against which to compare the activity of other fibrinolytic enzymes. Moreover, antibodies have been developed that are specifically reactive with or specifically bind to only some of the fragments, thereby permitting molecular identification of fragments with great accuracy and precision (Kudryk et al. 1989a). Using this knowledge, fibrinolytic activity of an endogenous matrix metalloproteinases has now been unexpectedly identified, thereby enabling development of the method of the invention.

**[0057]** The invention provides, *inter alia*, a method of degrading fibrin(ogen). Generally, the method requires the use of a fibrinolytic matrix metalloproteinase that possesses enzymatic activity against, i.e., can hydrolyze, fibrin and/or fibrinogen. The method includes contacting fibrin(ogen) with an effective amount of a fibrinolytic matrix metalloproteinase, preferably MT1-MMP.

**[0058]** The method of the invention can be performed *in vitro*. *In vitro*, the method can comprise contacting a tissue sample, such as blood or plasma, with at least one fibrinolytic matrix metalloproteinase. In this method, fibrin may be degraded as a constituent of clots and/or atherosclerotic plaques for purposes of investigating the structure of such materials, as well as for further investigation of the mechanisms of fibrinolysis and thrombolysis. Fibrinogen may be degraded for experimental or diagnostic purposes related to the formation of fibrin or to prevent potential growth of a fibrinogen-fibrin mesh. Other *in vitro* applications include methods in which purified samples of fibrin(ogen) are cleaved using the fibrinolytic MMP, to examine cleavage patterns, e.g., in conjunction with other known fibrinolytic or thrombolytic agents.

**[0059]** In a preferred diagnostic method, the method includes contacting a sample containing fibrin(ogen) with at least one fibrinolytic matrix metalloproteinase to provide degradation products (cleavage products). Preferably, the method includes analyzing the degradation products to characterize the fibrin(ogen). Such analysis typically includes differentially separating the various degradation products. The degradation products can be identified or measured by various means. For example, the fragments can be detected through antibodies that specifically bind to or associate with particular region(s) of fibrin(ogen), or fail to associate with them due to loss of epitope induced by enzymatic degradation. Preferably, such antibodies are monospecific, more preferably monoclonal. Synthetic and/or chimeric antibodies may be used, as may antigen binding regions such as Fab and  $F(ab')_2$ . Measurement of specific association between such antibodies and degradation fragments can provide qualitative, or quantitative information about the fibrin(ogen) sample being analyzed. Such antibodies can be detectably labeled to aid in the measurement of the types and amounts of the degradation products. Alternatively, antibodies affixed to solid substrates can be employed to aid in the separation or purification of degradation fragments produced by a fibrinolytic matrix metalloproteinase.

**[0060]** In another embodiment, the invention is a method of performing thrombolytic, embolytic, or atherolytic therapy in a vertebrate subject, preferably a primate, more preferably a human. In this embodiment, the invention involves administering to a subject a therapeutically effective amount of at least one fibrinolytic matrix metalloproteinase. Typi-

cally, the fibrinolytic matrix metalloproteinase is administered in a therapeutic composition comprising the MMP and a pharmacologically acceptable carrier or diluent. Optionally, the administered composition can further include one or more other active ingredients as an adjuvant to the fibrinolytic activity of the metalloproteinase. Suitable adjuvant compounds include compounds having thrombolytic or fibrinolytic activity. For example, the at least one adjuvant compound can be a plasminogen activator, hirudin, an enzyme inhibitor, an anticoagulant, an antibody or synthetic peptide specific for platelet  $\text{GPIIb/IIIa}$  receptor, or a combination thereof.

**[0061]** The method can be used prevent or ameliorate complications associated with rheumatoid arthritis, atherosclerosis (i.e., to degrade fibrinogen and fibrin in plaques before occlusion occurs), as well as to prevent reocclusion following thrombolytic therapy, e.g., with t-PA, following myocardial infarction. In fact, t-PA is fast-acting, while metalloproteinases such as MT1-MMP has a slower and progressive action. Thus, the compounds can be beneficially used in combination, including sequential or concurrent usage. The method can also be used as a prophylactic agent to inhibit restenosis following surgical intervention, such as bypass surgery or angioplasty. Alternatively, the method can be used in atherolytic therapy, to inhibit the initial formation, or promote the regression, of atherosclerotic plaques.

**[0062]** The invention further provides a method of controlling formation of thrombus caused by medical-related apparatus. In this embodiment, the method includes contacting a medical-related apparatus with a composition that includes a fibrinolytic matrix metalloproteinase, preferably MT1-MMP. The metalloproteinase desirably adheres or binds to a surface of the apparatus. The method can be used to modify blood-contacting surfaces of implantable prosthetic devices such as cannulae, catheters, grafts, stents, filters, coils, valves, and the like, to provide surfaces that inhibit the formation of clots or plaques. Alternatively, the method enables the modification of apparatus such as needles, blood collection tubes, culture flasks, test plates, pipets, reagent containers, tubing, membranes, and the like, to promote fibrinolysis and to inhibit the polymerization of fibrinogen and the formation of thrombus that might otherwise interfere with the experimental protocols. Likewise, the invention provides medical-related apparatus such as implantables, labware, and other devices for *in vivo* and *in vitro* uses, which apparatus has been modified to include adhered matrix metalloproteinase.

**[0063]** In still another embodiment, the invention provides a method of enhancing the regulation of fibrinolysis in a subject in need of such therapy. In this embodiment, the method of the invention includes inducing enhanced regulation of a fibrinolytic matrix metalloproteinase in a subject. Preferably, the method involves increasing the activity or expression of an endogenous fibrinolytic matrix metalloproteinase by treating the subject with somatic cell gene transfer therapy. Alternatively, the method involves decreasing the activity or expression of an endogenous fibrinolytic matrix metalloproteinase by treating the subject with somatic cell gene transfer therapy. Other therapeutic approaches can be employed that involve pharmaceutical compositions for either promoting or inhibiting the activity or the expression of an endogenous fibrinolytic matrix metalloproteinase.

**[0064]** The invention further includes compositions including a fibrinolytic matrix metalloproteinase, optionally also including other active and/or inert ingredients. Other active ingredients can include such ingredients as inhibitors of MMPs, plasminogen activators, other MMPs, anti-coagulation reagents, etc. Should another active ingredient be employed, it is preferred to include in the composition a plasminogen activator. The method of the invention can include plasminogen activators such as urokinase plasminogen activator (u-PA), tissue-type plasminogen activator (t-PA), staphylokinase, streptokinase, and the like, as well as recombinant, synthetic, or semisynthetic forms thereof.

**[0065]** The invention also now permits the investigation of the interaction of MMPs with plasminogen activators, plasminogen activator inhibitors (e.g., PAI-1), and native plasminogen.

**[0066]** It may also be desirable to include in the composition of the invention an anticoagulation agent such as heparin, to inhibit or prevent re-coagulation. Such measures would be less critical in *in vitro* applications, but could be significantly helpful in *in vivo* applications. The combination of t-PA with heparin to define a dual-functional thrombolytic composition is illustrated in U.S. Patent No. 5,130,143.

**[0067]** In one preferred embodiment, the method of the invention permits fibrinolytic therapy of a mammalian, preferably human, subject. In this embodiment, the method includes the administration to a subject of a therapeutically effective amount of a matrix metalloproteinase that degrades fibrin(ogen). As noted herein above, the fibrinolytic matrix metalloproteinase is preferably endogenous to the species of the subject undergoing therapy, and is preferably a membrane-type metalloproteinase, more preferably MT1-MMP. The therapeutic method can be employed for thrombolysis, or for prevention of progression and facilitation of regression of atherosclerotic plaques. Thus, the method can be performed for acute or emergency therapy, or for prolonged or chronic maintenance therapy, to reduce the likelihood of or inhibit the development of abnormal thrombi, emboli or atherosclerotic plaques.

**[0068]** Modes of administration of such a composition are known in the art, and are related to those techniques employed in the administration of conventional thrombolytic agents. Such methods include, without limitation, parenteral methods, preferably intravascular methods such as intravenous injection, intraarterial injection, and administration by intravascular catheter.

**[0069]** The determination of the effective amount of a composition of the invention is within the skill and discretion of the practicing clinician. Specific prophylactic or therapeutic dosages and the timing of administration can be selected

depending upon prevailing conditions to achieve clinically acceptable treatment. The skilled clinician will take into account such factors as the age, sex, weight, and condition of the subject, as well as the route of administration. The skilled clinician will also recognize that the fibrinolytic activity of MMPs can be supplemented by the collateral administration (e.g., co-administration or sequential administration) of other active and/or inert substances. For example, it can be desirable to administer adjuvant agents having thrombolytic activity. These agents can have direct fibrinolytic activity or can be regulators or modulators of fibrinolysis in the system in which they are employed. For example, agents having thrombolytic activity include plasminogen activators, hirudin, enzymes (e.g., proteases derived from snake venom), enzyme inhibitors, anticoagulants (e.g., heparin, aspirin), antibodies (preferably monoclonal antibodies) or synthetic peptides specific for platelet GPIIb/IIIa receptor, or a combination thereof. Various such thrombolytic agents are described in Collen (1996). These agents can be administered together with or ancillary to the administration of an MMP-containing composition. Thus, such other agent or agents can be included in the MMP-containing composition, or can be administered as part of another composition.

**[0070]** In another embodiment, the invention includes targeted fibrinolytic matrix metalloproteinases, i.e., MMPs that are bound to moieties having specificity for a biological target molecule. For example, a metalloproteinase can be bound to an antibody by methods known in the art for attaching proteins to antibodies. In this way a metalloproteinase can be preferentially directed to a fibrin(ogen) substrate for improving fibrin(ogen)olytic efficacy. Thus, a fibrinolytic matrix metalloproteinase such as MT1-MMP can be linked to antibodies having specificity for fibrin or a degradation product thereof, to platelets, specifically to P-selectin, to oxidized lipoproteins, etc.

**[0071]** The invention also provides a diagnostic method for the characterization of fibrin- and fibrinogen-related analytes. In this method, fibrin(ogen) can be contacted with a fibrinolytic MMP, preferably MT1-MMP, to produce degradation products. The degradation products are then analyzed to determine the types and amounts of cleavage products generated by the activity of the MMP. By using several MMPs having distinct cleavage patterns, further characterization and understanding of the products can be obtained, permitting more accurate and precise diagnostic results.

**[0072]** Typically, the method involves the differential separation of degradation products, such as separation of the products by gel electrophoresis. The products are then measured such as by non-specific staining to reveal quantities of products of different sizes. Alternatively, the products can be identified by contacting the products with antibodies that specifically bind with one or more domains of fibrin(ogen) (Kudryk et al. 1989a). Preferably, such antibodies specifically bind with a single degradation product, thereby permitting characterization of that product in relation to other products.

**[0073]** New antibodies, useful according to the diagnostic method of the invention, can be developed and detectably labeled with any detectable marker group. Suitable marker groups include, for example, fluorescent labels, enzyme labels, and radioactive labels. Detector groups useful according to the invention include, for example, fluorescein as a fluorescent label, horseradish peroxidase as an enzyme label, and Iodine-125 ( $^{125}\text{I}$ ) as a radioactive label. Additional fluorescent labels that can be utilized in the invention include, but are not limited to, rhodamine, phycoerythrin and additional compounds emitting fluorescent energy. Additional enzyme labels that can be utilized in this invention include, but are not limited to, glucose oxidase and alkaline phosphatase. Additional radioactive labels that can be utilized in this invention include, but are not limited to, Iodine-131 ( $^{131}\text{I}$ ) and Indium-111 ( $^{111}\text{In}$ ).

**[0074]** Suitable detectable labels can be selected from among those known in the art, such as radioactive labels, enzymes, specific binding pair components, colloidal dye substances, fluorochromes, reducing substances, latexes, digoxigenin, metals, particulates, dansyl lysine, antibodies, protein A, protein G, electron dense materials, chromophores, and the like. Effectively, any suitable label, whether directly or indirectly detectable, can be employed. One skilled in the art will clearly recognize that these labels set forth above are merely illustrative of the different labels that could be utilized in the diagnostic method of the invention.

**[0075]** Fibrinogen subunit-reactive antibodies can also be derivatized by conjugation to biotin, and used, upon addition of species of avidins that have been rendered detectable by conjugation to fluorescent labels, enzyme labels, radioactive labels, electron dense labels, etc., in a multiplicity of immunochemical and immunohistological applications.

**[0076]** Alternatively, the method of the invention can be performed using antibodies that have been attached or bound to substrate materials according to methods known to those skilled in the art. Such materials are generally substantially solid and relatively insoluble, imparting stability to physical and chemical disruption of the antibodies, and permitting the antibodies to be arranged in specific spatial distributions. Among substrate materials, materials can be chosen according to the artisan's desired ends, and include materials such as gels, hydrogels, resins, beads, nitrocellulose, nylon filters, microtiter plates, culture flasks, polymeric materials, and the like, without limitation.

**[0077]** The method of the present invention can involve immunological assays to determine the presence of fibrin(ogen) breakdown products in tissue samples from human or animal subjects. Biopsy and necropsy samples of subjects, as well as samples from tissue libraries or blood banks, can be evaluated for the presence of fibrin(ogen) MMP breakdown fragments using an anti-fibrinogen antibodies. Moreover, suitable preparations can be devised for *in vivo* use, such as for the visualization of fibrinogen or fibrinogen-containing substances and structures in a living subject. In this way the progression of fibrinolysis induced by MMPs can be assessed *in situ*.

**[0078]** In one such embodiment, a fibrinolytic matrix metalloproteinase, preferably MT1-MMP, is bound to a sub-

strate material such as a membrane, blood collection tube, microtiter plate, culture flask, or the like. In this manner, the method of the invention can be performed in the absence of soluble MMP, to induce fibrin(ogen)olysis in a fluid sample. Alternatively, this approach is useful in coating membranes and prosthetic devices.

5 **[0079]** Indeed, in another embodiment, the invention includes a method of controlling formation of clots or plaques caused or induced by medical-related apparatus. In this embodiment, the method includes contacting a medical-related apparatus with a composition that includes a fibrinolytic matrix metalloproteinase, preferably MT1-MMP. This method can be used to cause a metalloproteinase to bind or adhere to a surface. It is believed that any apparatus that would contact blood can be so modified by methods known in the art that permit the attachment of proteins to substrate materials. For example, the method can be used to modify blood-contacting surfaces of implantable prosthetic devices such as cannulae, catheters, grafts, stents, filters, coils, valves, and the like, to provide surfaces that inhibit the formation of thrombus. Alternatively, the method enables the modification of apparatus such as blood collection tubes, culture flasks, test plates, pipets, reagent containers, tubing, membranes, and the like, to promote fibrinolysis and to inhibit the formation of thrombus that might otherwise interfere with the experimental protocols. Likewise, the invention provides medical-related apparatus such as implantables, labware, and other devices for *in vivo* and *in vitro* uses that possess the capacity or inhibiting thrombus formation by promoting the degradation of fibrin(ogen). The metalloproteinase can be adhered to an apparatus either permanently or reversibly, such as for delivery of metalloproteinase from an apparatus into solution.

10 **[0080]** In addition, the invention provides diagnostic and therapeutic kits that include a fibrinolytic matrix metalloproteinase as described. Kits according to the invention can include one or more containers, as well as additional reagent(s) and/or active and/or inert ingredient(s) for performing any variations on the method of the invention. Exemplary reagents include, without limitation, synthetic substrates to test enzymatic activity, and antibodies (preferably monospecific, e.g., monoclonal) to measure increase or decrease of antigen level. Preferred kits include at least one therapeutically effective unit dose of a fibrinolytic matrix metalloproteinase, e.g., MT1-MMP. Also preferred are kits that include means for administering, preferably parenterally, more preferably intravenously, a composition containing a fibrinolytic matrix metalloproteinase. The kits can include one or more other active ingredients as adjuvants, such as plasminogen activators, hirudin, or anti-coagulants such as heparin or aspirin. These other ingredients can be included in separate compositions in separate reagent containers, or can be included with each other and/or the matrix metalloproteinase in a single reagent container. The kit can also comprise means for administering a therapeutically effective amount of the composition, preferably means for administering the composition parenterally, such as catheterization or syringe apparatus. The kits can also include instructions for mixing or combining ingredients or use of the kit according to the invention.

15 **[0081]** The invention also provides a method of enhancing regulation of fibrinolysis in a subject in need of such therapy. In this embodiment, the method of the invention includes inducing enhanced regulation of an endogenous fibrinolytic matrix metalloproteinase in a subject. Preferably, the method involves increasing or decreasing the activity or expression of a matrix metalloproteinase by treating the subject with somatic cell gene transfer therapy. Any gene therapy approach can be employed according to this embodiment. Thus, up-regulation of MMP expression can be accomplished by introducing a gene for an endogenous matrix metalloproteinase by *ex vivo* or *in vivo* gene transfer techniques. Alternatively, up-regulation of an MMP can be accomplished by inhibiting the expression of an MMP inhibitor via anti-sense technology. Down-regulation of MMP activity can be accomplished by these techniques, the design and implementation of which are within the skill of those in the art. A brief overview of several gene therapy methods is provided in Glick et al. (1994), which is incorporated herein by reference. Other therapeutic approaches can be employed that involve pharmaceutical compositions for either promoting or inhibiting the activity or the expression of an endogenous fibrinolytic matrix metalloproteinase. Given the complexity of the fibrinolytic regulation system, and given the unexpected role of MMPs in that regulatory scheme, it would appear to those skilled in the art that many potential avenues exist for adjustment of the fibrinolytic regulatory status of a subject.

20 **[0082]** The following examples are intended to assist in a further understanding of the invention. The particular materials and conditions employed are intended to be further illustrative of the invention and are not limiting upon the reasonable scope thereof.

25 **[0083]** In the following examples, we describe our experiments that have revealed the effect of membrane type 1-MMP (MT1-MMP). We have determined that MT1-MMP also solubilizes fibrin clots similarly to MMP-7. It was recently shown that MT1-MMP can degrade a number of substrates in the extracellular matrix (3). Therefore, we determined the ability of MT1- and MT2-MMPs to degrade fibrin(ogen), which contribute an additional source of fibrin(ogen)-degradation products in a number of diseases, such as rheumatoid arthritis. See Examples 12 and 13.

30 **[0084]** In addition, we describe our experiments that have revealed the role that fibrinolytic MMPs, particularly MMP-3 and MMP-7, play in the degradation of fibrinogen (Fg) and cross-linked fibrin (XL-Fb). We have studied the following aspects: 1) degradation of Fg; 2) effect of MMPs-digestion of Fg on its subsequent clottability with thrombin; 3) lysis of XL-Fb and purified Fragment D-dimer (DD); 4) NH<sub>2</sub>-terminal analyses of chain fragments of selected digests; 5) reactivity of the cleaved fragments with a number of specific monoclonal antibodies. We show the ability of MMP-3 and

MMP-7 to degrade Fg and to lyse XL-Fb clots. Based on this work, we conclude that both matrix metalloproteinase 1 (MMP-1) and matrix metalloproteinase 2 (MMP-2) can partially degrade Fg, and that MMP-2 has a limited capacity to degrade XL-Fb. We have also determined that, in XL-Fb, the  $\gamma$ Gly404-Ala405 bond is a major MMP-3 cleavage site, leading to the formation of a Fragment D-like monomer. This indicates a specific mechanism of fibrin degradation, different from plasmin, by an endogenous MMP. See Examples 1-11.

**[0085]** The following experimental procedures are relevant to Examples 1-13, below:

*Proteins and Other Reagents.* Plasminogen-free and fibronectin-free Fg (Fg  $\geq$  95% clottable) or lyophilized human Fg were purchased (American Diagnostica Inc., Greenwich, CT). Plasminogen and fibronectin were removed by affinity chromatography on lysine-Sepharose and gelatin-Sepharose, essentially as described by others (Deutsch et al. 1970; Engvall et al. 1977; Procyk et al. 1985). The amount of Factor XIII in these preparations is 0.1-0.2 Loewy units/mg of Fg according to the manufacturer. Stock solutions of Fg (12 mg/mL in TNE buffer (0.05 M Tris-HCl (pH 7.4), containing 0.1 M NaCl, 0.001 M EDTA and 100 KIU/mL aprotinin)) were stored at  $-70^{\circ}\text{C}$  until used. Fg concentration was measured spectrophotometrically in alkaline-urea using extinction coefficient (1%, 1 cm) = 16.5 at 282 nm. Human Glu-Plasminogen (1 U/0.5 mg) was from Imco (Stockholm, Sweden). Streptokinase (4500 u/mg solid), bovine serum albumin (BSA, Fraction V, RIA-grade), 4-aminophenylmercuric acetate (APMA) and EDTA were from Sigma Chemical Company (St. Louis, MO). Aprotinin was from Mobay Chemical Corp (New York, NY). Human  $\alpha$ -thrombin (2300 U/mg) was a generous gift of Dr. J. Fenton.  $^{125}\text{I}$ -Fg, labeled by the iodogen method (specific activity  $1.5 \times 10^6$  cpm/ $\mu\text{g}$  protein) was a generous gift of Drs. M. Nag and D. Banerjee, Laboratory of Membrane Biochemistry II, The New York Blood Center. Pro-MMP-1, pro-MMP-2, and pro-MMP-3 were purified as previously described by others (Okada et al. 1986; Okada et al. 1990; Suzuki et al. 1990). All other reagents were of analytical grade and were purchased from Fisher Scientific (Springfield, NJ), e.g., pro-MMP-3 and  $\Delta$ MMP-3 from Dr. H. Nagase (University of Kansas Medical Center, Kansas City, KS) and Dr. R. Palermo (Roche, Nutley, NJ); pro-MMP-9 was from Dr. W. Stetler-Stevenson, NIH, Bethesda, MD); MT1-MMP and MT2-MMP were purchased from In Vitex (Berlin, Germany). All other reagents were of analytical grade and were purchased from Fisher Scientific (Springfield, NJ).

*Gel electrophoresis/Immunoblotting.* Samples of Fg and XL-Fb degraded with plasmin or MMPs were subjected to SDS-PAGE using both reducing and non-reducing conditions. Reduced samples were prepared in 62.5 mM Tris buffer, pH 6.8, containing 4% SDS, 8 M urea, 5% DTT, 10% glycerol and 1% bromphenol blue. Non-reduced samples were made in the same buffer without DTT. SDS-PAGE was performed using 5-15% gradient or 12.5% polyacrylamide gels in Tris-glycine buffer (Laemmli 1970) or with 5% and 7.5% mini gels in phosphate buffer (McDonagh et al. 1972) following general procedures. Prestained molecular weight standards used were myosin (200 kDa), phosphorylase B (97.4 kDa), BSA (68 kDa), ovalbumin (43 kDa),  $\alpha$ -chymotrypsinogen (25.7 kDa),  $\beta$ -lactoglobulin (18.4 kDa) and lysozyme (14.3 kDa) (Bethesda Research Laboratories, Gaithersburg, MD). Transfer to nitrocellulose membranes for immunoblot analyses was performed as described by Towbin et al. (1979) with few modifications (Kudryk et al. 1989b). In some experiments, membranes were stained with colloidal gold prior to immunoblotting (Colloidal Gold Total Protein Stain, BioRad, Hercules, CA). Membranes were blocked with 5% dry milk (Carnation, Nestle, Glendale, CA) or with 5% BSA, incubated overnight with a selected primary antibody (Table II) and then probed with a second antibody. Rabbit anti-mouse-horseradish peroxidase (RAM-HRPO) was prepared as described by Goding (1986) using RAM purchased from Dako (Carpinteria, CA) and HRPO (type VI) from Sigma. Bound peroxidase complexes were detected using the chemiluminescent substrate Luminol (ECL Western blotting detection system, Amersham Life Science, Arlington Heights, IL). Light emitted from the hydrolysis of the added Luminol substrate exposed the provided film (Kodak  $\chi$ -Omat RP, Eastman Kodak Company, Rochester, NY) in 10 to 30 seconds.

## EXAMPLE 1

**[0086]** *Degradation of Fibrinogen.* An experiment was performed to evaluate whether MMPs possess fibrinolytic activity. Fibrinogen (Fg) (120  $\mu\text{g}$ , 3.5  $\mu\text{M}$ ) was incubated with MMP-2 or MMP-3 (6  $\mu\text{g}/\text{mL}$  or 1:20 E:S ratio) at  $37^{\circ}\text{C}$  for different time intervals. Pro-MMP-2 and pro-MMP-3 (in 50 mM Tris-HCl, pH 7.5, 0.15 M NaCl, 0.05% Brij 35, 0.05%  $\text{NaN}_3$ ) were activated with 1 mM APMA at  $37^{\circ}\text{C}$  for 45 min and 24 hr, respectively, prior to addition to the Fg solutions. All reactions were in the presence of 10 mM  $\text{CaCl}_2$  at  $37^{\circ}\text{C}$ . Digestions were terminated by addition of EDTA (25 mM final concentration). Reaction products were mixed with reducing or non-reducing buffer and subjected to SDS-PAGE separation (12.5%). The gels were stained for protein with Coomassie blue.

**[0087]** Figure 1 shows the time-dependent digestion of fibrinogen by MMP-2 and MMP-3 by comparison to non-digested fibrinogen. The enzymes were used at E:S = 1:20 (w/w) and incubation was for 1, 2, 4 and 24 hrs. The key to Figure 1 is as follows:

5

10

15

Lane No.	Sample
1	Non-digested fibrinogen
2	MMP-2 digest of Fg (1 hr)
3	MMP-2 digest of Fg (2 hrs)
4	MMP-2 digest of Fg (4 hrs)
5	MMP-2 digest of Fg (24 hrs)
6	MMP-3 digest of Fg (1 hr)
7	MMP-3 digest of Fg (2 hrs)
8	MMP-3 digest of Fg (4 hrs)
9	MMP-3 digest of Fg (24 hrs)

20 **[0088]** It is clear from Figure 1 that, using MMP-2 and MMP-3 in comparable amounts (6  $\mu\text{g}/120 \mu\text{g}$  Fg), both the  $\text{A}\alpha$ - and  $\text{B}\beta$ -chains of Fg were extensively degraded in 1 hr (lanes 2 and 6). A longer (24 hr) incubation resulted in further cleavage of both chains (lanes 5 and 9). Degradation of Fg  $\gamma$ -chains with MMP-3 was extensive at 24 hr (Figure 8, lane 9) and different from that with MMP-2 (lane 5). Significant degradation with MMP-2 and MMP-3 was also obtained at lower concentration of enzyme (0.2-0.6  $\mu\text{g}/120 \mu\text{g}$  Fg, data not shown). MMP-1, was also tested using this protocol, and, at the highest concentration (6  $\mu\text{g}/120 \mu\text{g}$  Fg), showed apparently intact  $\text{B}\beta$ - and  $\gamma$ -chains and only partial degradation of the  $\text{A}\alpha$ -chains (data not shown).

## EXAMPLE 2

30 **[0089]** *Coagulability of Fibrinogen Degraded with MMP-3.* Digests (1.5 and 3 hrs) of fibrinogen with MMP-2 and MMP-3 were prepared as described above. A plasmin digest of Fg (18-20 hr) (Gårdlund et al. 1972) was used as control. Intact Fg and Fg digests were clotted with thrombin as described by Bini et al. (1994). Briefly, 1.2 mg Fg/mL, or any of the above MMP-2 and MMP-3 digests of fibrinogen, was clotted with thrombin (0.4 NIH U/mL) in the presence of 20 mM  $\text{CaCl}_2$ . Clotting time was determined as an increase in turbidity and read at 350 nm (Blombäck et al. 1982). Coagulability was determined from the plot of turbidity versus time. A tangent was drawn to the steepest part of the curve; its intersection with the time axis is defined as clotting time (Blombäck et al. 1994). In all cases, the gels were formed without any observed precipitation. Clot supernatants were run on HPLC (Kudryk et al. 1989b) in order to determine release of fibrinopeptides A (FPA) and B (FPB). These results are tabulated in Table I, below.

40

45

50

55

TABLE I  
Thrombin Clotting Times

Sample	ES	Concentration	Incubation	Thrombin	Turbidity	Turbidity
	w/w	$\mu\text{g}$	time (hrs)	time	(same day)	(next day)
Fg control (untreated) (120 $\mu\text{g}$ )	-	-	-	66"	0.341	0.373 (n=5)
MMP-2	1:500	0.2	1.5	>15 min	-	0.322
			"	uncloitable	-	0.022
			3	soft clot	-	0.103
			"	next day	-	-
"	1:200	0.5	1.5	> 10 min	0.433	0.363
			"	12'01	0.377	0.323
			3	>1 min	0.331	1.039
			"	>1 min	0.753	1.125
MMP-3	1:500	0.2	1.5	> 10 min	-	0.025
			"	uncloitable	-	0.035
			3	soft clot	-	0.004
			"	the next day	-	0.029
"	1:200	0.5	1.5	> 10 min	-	0.001
			"	uncloitable	-	0
			3	no clot	-	0.008
			"	the next day	-	0.012
Plasmin	1:1200	0.1	1.5	107.5"	0.396	all
			"	103.9"	0.399	clots
			3	60.5" ?	0.436	digested
			"	139.1"	0.502	C.N.
"	1:240	0.5	1.5	uncloitable	-	-
			"	"	-	-
			3	"	-	-
			"	"	-	-

[0090] Fg digested with MMP-2 (1.5 and 3 hr) did not clot within 10 min (arbitrarily taken as maximum time), but was still capable of forming a fibrin gel after overnight incubation with thrombin as shown by the turbidity data (Table I). By contrast, both MMP-3- and plasmin-digests, at comparable time and concentration, were unclottable even after overnight incubation. Turbidity data indicated that gelation was obtained only from reaction mixtures of Fg digested with MMP-2 and with the lowest plasmin concentration. Furthermore, turbidity values of the same preparations measured the next day showed that reaction mixtures of Fg and MMP-2 were similar to control while Fg digests generated by MMP-3 or plasmin had low or no turbidity (Table I). HPLC profiles of supernatants from all digests showed normal release of fibrinopeptides A and B with thrombin (not shown).

### EXAMPLE 3

[0091] *Degradation of Cross-Linked Fibrin.* Fibrin clots were made from purified fibrinogen according to the method

of Bini et al. (1994) and the references cited therein. Radiolabeled clots were made with 0.1 mL purified Fg (1.2 mg/mL in TNE buffer) containing <sup>125</sup>I-Fg (20,000 cpm) in the presence of 20 mM CaCl<sub>2</sub>. Thrombin (1.5 NIH U/mL, final concentration) was added and samples were incubated at 37 °C for 18-20 hrs (Bini et al. 1994). Active MMP-1, MMP-2, or MMP-3 were added in different amounts (2-60 µg/mL, corresponding to 1:600-1:20 E:S ratio) in the presence of 10 mM CaCl<sub>2</sub>. Plasmin was generated by adding plasminogen (50 µg/mL) and streptokinase (1080 U/mL) to the fibrin clots (approximately 0.02-0.5 U/mL plasmin, final concentration, corresponding to 1:1200-1:48 E:S). Clots were gently dislodged from the wall of the test tube with a wooden stick and the content lightly vortexed after addition of each enzyme. Incubation times were from 1-48 hrs at 37 °C. Digests with MMPs were terminated by addition of EDTA (25 mM final concentration), and those with plasmin were terminated with 5,000 KIU/mL aprotinin. Clots were separated from supernatants by centrifuging at 13,000 rpm for 20 min in a Sorvall RCL-B (SS-34 rotor). Fibrinolysis was measured both by release of radioactivity into the supernatant (A) and by residual radioactivity in each clot (B). Samples were counted in a Packard Auto-γ-5000 Series Gamma Counter. Control fibrin clots, with and without digestion with the different enzymes, were made at the same time to be used for SDS-PAGE. Data represent mean values of 2-4 separate experiments.

**[0092]** The results of this experiment are presented in Figures 2A and 2B, that show the percent radioactivity in the supernatants (Fig. 2A) and in the residual clots (Fig. 2B). As shown, after 24 hours of incubation, both the MMP-3 (6 µg/120 µg Fg) and plasmin (0.02 IU/mL) samples showed release of over 80% of the radioactivity into the supernatants (average of three experiments) (Fig. 2A). Residual radioactivity in the clots at 24 hrs was less than 10% (Fig. 2B), and the clots appeared dissolved by both MMP-3 and plasmin. See Figures 2A and 2B. The concentration of plasmin used in the lysis experiments was chosen on the basis of obtaining a slow lysis (Liu et al. 1986). In preliminary experiments, similar release of radioactivity was measured in the supernatants using plasmin at 1:240 and 1:1200 (E:S, w/w), which was used throughout the study. Degradation with MMP-2 at highest concentration at 24 hr, was similar to that obtained with MMP-3 at 1:200. Degradation with MMP-1 at highest concentration, after 48 hr, was similar to MMP-3 at 1:1200. Controls, with no addition of enzyme as well as a plasmin digest of XL-Fb, are also shown.

**[0093]** Incubation with a mixture of MMP-3 and plasmin in the sample produced results similar to those produced by either enzyme alone (data not shown). This indicates that the two enzymes do not interfere with one another. Identical experiments were performed using clots made from plasma, and similar results were obtained (data not shown).

EXAMPLE 4

**[0094]** *Chain Composition of XL-Fb Degraded by MMPs and Plasmin.* The digestion of cross-linked fibrin by plasmin, MMP-2 and MMP-3 was analyzed. Samples of fibrin degradation by each of the enzymes were reduced and subjected to SDS-PAGE (5-15% gradient) (Laemmli et al. 1973; McDonagh et al. 1972). Following electrophoresis, resolved proteins were transferred to nitrocellulose. Protein was stained with colloidal gold on the nitrocellulose membrane. The patterns of dose-dependent and time-dependent degradation of fibrinogen and fibrin by MMP-2, MMP-3 and plasmin are shown in Figure 3.

**[0095]** The key to Figure 3 is as follows:

Lane No.	Sample
1	Fibrin degraded with plasmin (1:1200) for 24 hrs
2	Fibrin degraded with plasmin (1:240) for 24 hrs
3	Fibrin degraded with MMP-2 (1:200) for 24 hrs
4	Fibrin degraded with MMP-2 (1:20) for 24 hrs
5	Fibrin degraded with MMP-3 (1:600) for 24 hrs
6	Fibrin degraded with MMP-3 (1:200) for 24 hrs
7	Fibrin degraded with MMP-3 (1:20) for 24 hrs
8	Fibrin degraded with MMP-3 (1:10) for 24 hrs

**[0096]** Figure 3 shows plasmin degradation of cross-linked fibrin γ-dimer chain (94 kDa) into DD γ-dimer chain (76 kDa) at higher E:S ratio (lanes 1 and 2). No degradation of cross-linked fibrin γ-dimer was observed with MMP-2, at highest E:S (1:20) (lane 4). Significant degradation of the γ chain was obtained with MMP-3 (E:S = 1:20) at 24 hrs (lane

7) and complete degradation was obtained by increasing E:S two-fold (lane 8). The pattern of degradation of cross-linked fibrin  $\gamma$ -dimer chain by MMP-3 is different from that obtained with plasmin. In fact, plasmin decreases the molecular weight of the  $\gamma$  dimer, but does not monomerize it (lanes 1, 2) even at higher E:S ratio (1:240).

[0097] The XL-Fb clots were gradually degraded by MMP-3 and resulted in near complete lysis at 24 hr. The amount of degradation with MMP-3 (1:20) at 24 hrs was comparable to that produced by plasmin (1:1200). Therefore, MMP-3 is a slower enzyme than plasmin. The rates of clot solubilization with MMP-1 and MMP-2 were much slower: at the same E:S ratio (1:20), only 34% and 58% respectively, was solubilized after 24 hr, whereas 84% was degraded by MMP-3. In digests with MMP-3 and plasmin, residual clot radioactivity was  $\leq 10\%$ . These results indicated that digestion of XL-Fb with MMP-3 progressed further, possibly with a different and more specific mechanism than that obtained with either MMP-1 or MMP-2. However, the weaker activity of MMP-2 may be due to rapid autolysis of the enzyme after activation by APMA (Okada et al. 1990).

**EXAMPLE 5**

[0098] *MMP-3-Induced Cleavage of  $\gamma$ -Chain Cross-Link Domain.* Immunoblots performed using standard techniques were performed on plasmin and metalloproteinase digests of fibrin with a panel of monoclonal antibodies (MoAbs) (see Table II) to identify how the three chains of fibrin are cleaved by MMP-3 in comparison with plasmin. Monoclonal antibodies were prepared according to techniques known in the art.

TABLE II

MONOCLONAL ANTIBODIES		
Antibody	Isotype	Cross-Reacts With:
MoAb/4A5 D/D-dimer (Gift)	IgG1,k	$\gamma$ 397-311, native fibrinogen and fragments (Matsueda et al. 1988)
MoAb/4-2	IgG1,k	$\gamma$ 392-406, fibrinogen and fragments D/D-dimer <u>but only after denaturation</u> (Kudryk et al. 1991)
MoAb/T2G1	IgG1,k	B $\beta$ 15-42, fibrin II, <u>but not fibrinogen/fibrin I</u> (Kudryk et al. 1984)
MoAb/1D4	IgG1,k	A $\alpha$ 349-406, fibrinogen, fibrin, and plasmin digests of both (Procyk et al. 1991)

[0099] Samples were incubated either with or without enzyme for 24 or 48 hr. Incubated samples were then subjected to SDS-PAGE (7% gels) under reducing conditions. After electrophoresis, samples were transferred to nitrocellulose membranes, and the membranes were blotted with selected antibodies. Specific antibody-bound fibrin(ogen) chains were detected using RAM-HRPO and the chemiluminescent substrate, as described above. The results are illustrated in Figures 4-5.

[0100] Figure 4A shows immunoblots of the degradation products of fibrin digestion by MMP-3 and plasmin with MoAb/4-2. This antibody is specific to an epitope in the  $\gamma$ -chain:  $\gamma$ 392-406. This antibody reacts with fibrinogen and the D and D-dimer fragments only after denaturation.

[0101] Cross-linked fibrin and fibrinogen were each incubated without enzyme at 37 °C, for 24 hr. Also, XL-Fb was incubated with plasmin (24 hr) and with MMP-3 (24 hr and 48 hr). The digests were examined under reducing conditions. The key to Figure 4A is as follows:

Lane No.	Sample
1	XL-Fb
2	Fg
3	Plasmin digest of XL-Fb (24 hr)
4	MMP-3 (1:20) digest of XL-Fb, residual clot (24 hr)
5	MMP-3 (1:20) digest of XL-Fb, total digest (48 hr)

[0102] As seen in Figure 4A, MoAb/4-2 (anti- $\gamma$ 392-406) reacted with both undigested XL-Fb  $\gamma$ -dimer (94 kDa, lane

1) and undigested Fg  $\gamma$ -chain (47 kDa, lane 2). Residual  $\gamma$ -chain monomer in the cross-linked fibrin preparation also reacted with MoAb/4-2 (lane 1). In the plasmin digest of XL-Fb, DD  $\gamma$ -dimer (76 kDa) and Fragment D  $\gamma$ -chain monomer (known to result from both Fg and XL-Fb plasmin digests (Siebenlist et al. 1992)) also reacted equally with MoAb/4-2 (lane 3). A 24 hr digest of XL-Fb generated by MMP-3 showed reduced DD  $\gamma$ -dimer chain in the residual clot, but significant amounts of Fragment D monomer-like  $\gamma$ -chain (36 kDa, lane 4). A longer incubation (48 hr) showed only Fragment D monomer-like  $\gamma$ -chain in the total digest. Digests with both enzymes bound MoAb/4-2.

**[0103]** Cross-linked fibrin was also examined by immunoblotting with MoAb/4A5, which is specific for the  $\gamma$ -chain at  $\gamma$ 397-411, an epitope close to that reactive with MoAb/4-2. As a benchmark, XL-Fb clot was incubated without enzyme at 37°C for 48 hr. XL-Fb was also incubated with MMP-3 or plasmin for 24 hr. The results of this immunoblot are shown in Figure 4B. The key to Figure 4B is as follows:

Lane No.	Sample
1	Undigested XL-Fb clot
2	MMP-3 (1:20) digest of XL-Fb, residual clot (24 hr)
3	MMP-3 (1:20) digest of XL-Fb, clot supernatant (24 hr)
4	MMP-3 (1:20) digest of XL-Fb, total digest (24 hr)
5	Plasmin digest of XL-Fb

**[0104]** Thus, as seen in Figure 4B, MoAb/4A5 (anti- $\gamma$ 397-411) showed reactivity only with the  $\gamma$ -dimer band from both intact and plasmin-digested XL-Fb (lanes 1, 5) and with residual DD  $\gamma$ -dimer from digests generated by MMP-3 (lanes 2, 4). The Fragment D monomer-like  $\gamma$ -chain (36 kDa), fully reactive with MoAb/4-2 (Figure 4A, lanes 4, 5), failed to bind MoAb/4A5 (Figure 4B, lanes 2, 4). Immunoblot analysis of the same samples under non-reducing conditions showed similar loss of immunoreactivity with MoAb/4A5 (data not shown).

**[0105]** These experiments show that the pattern of XL-Fb degradation with MMP-3 is different from that obtained with plasmin. In digests with MMP-3 (1:20), only very small amounts of  $\gamma$ -dimer remain. At higher levels of this same enzyme, no dimers can be detected. MMP-2 does not seem to affect the degradation of  $\gamma$ -dimer significantly. Two monoclonal antibodies, MoAb/4-2 and MoAb/4A5, reactive with different epitopes in the sequence  $\gamma$ 392-411, were used to define the regions of cleavage of XL-Fb by MMP-3 in comparison to plasmin. This segment of the chain contains residues ( $\gamma$ Gln398 and  $\gamma$ Lys406) that participate in covalent cross-linking (forming  $\epsilon$ -( $\gamma$ -Glu)-Lys isopeptide bonds) on neighboring molecules leading to fibrin stabilization mediated by Factor XIIIa (Chen et al. 1971). MoAb/4A5 recognizes an epitope in the COOH-terminal region of this peptide ( $\gamma$ 397-411), while MoAb/4-2 reacts with its NH<sub>2</sub>-terminal end ( $\gamma$ 392-406). Both antibodies bind to microtiter plates coated with the plasmin-derived digest products Fragments D and DD. Only MoAb/4A5 competes with such fragments when each is in solution (Kudryk et al. 1991). In a 24 hr MMP-3-digest of XL-Fb, both residual DD  $\gamma$ -dimer chain and Fragment D monomer-like  $\gamma$ -chain were reactive with MoAb/4-2. Longer (48 hr) digests resulted in Fragment D monomer-like  $\gamma$ -chain only, which was still reactive with MoAb/4-2. Analysis of these same digests with MoAb/4A5 (anti- $\gamma$ 397-411) showed only the DD  $\gamma$ -dimer band to be reactive. The Fragment D monomer-like  $\gamma$ -chain failed to bind MoAb/4A5. These results suggested that a major MMP-3 cleavage site was within the  $\gamma$ -chain cross-link domain resulting in the degradation of the  $\gamma$ -dimer. Purified Fragment DD, was also cleaved with MMP-3 to a D-monomer like fragment.

**[0106]** Immunoblot of the degradation products of fibrin digestion by MMP-3 and plasmin was also performed using MoAb/T2G1 and MoAb/1D4 under reducing conditions, as shown in Figure 5. The experimental protocol was as described above for the other antibodies. The key to Figure 5 is as follows:

Lane No.	Sample
1	MMP-3 (1:200) digest of XL-Fb (24 hr)
2	MMP-3 (1:20) digest of XL-Fb (24 hr)
3	Undigested XL-Fb (24 hr)
4	MMP-3 (1:200) digest of XL-Fb (24 hr)

(continued)

Lane No.	Sample
5	MMP-3 (1:20) digest of XL-Fb (24 hr)
6	Undigested XL-Fb (24 hr)
7	Undigested Fg (24 hr)

5

10

**[0107]** As indicated in Figure 5, lanes 1-3 were blotted with MoAb/T2G1, while lanes 4-7 were blotted with MoAb/1D4.

15

**[0108]** MoAb/T2G1 is specific for B $\beta$ 15-42, but only of fibrin II, not of fibrinogen/fibrin I. MoAb/1D4 is specific for A $\alpha$ 349-406 in fibrinogen and fibrin, as well as in their plasmin digests. As shown in Figure 5, MoAb/T2G1 immunoreactivity was lost in the digests of fibrin by MMP-3 both at lower (1:200) and higher (1:20) concentration (lanes 4, 5), while it is present in intact fibrin (lane 6). MoAb/1D4 immunoreactivity is still partially preserved in the fibrin digest at lower concentration of MMP-3 (lane 1), but it is completely lost in digests at higher concentration of MMP-3 at both 24 hr (lane 2) and 48 hours (not shown), while it is clearly present in the control sample (lane 3).

20

**[0109]** Accordingly, MMP-3 degradation products of XL-Fb were probed with MoAbs, T2G1 (anti-B $\beta$ 15-42) and 1D4 (anti-A $\alpha$ 349-406), respectively. Both epitopes are present in XL-Fb. In plasmin digests of XL-Fb, many different size bands ( $\geq$ 20 kDa) react with MoAb/1D4, while all MoAb/T2G1 reactivity is lost. Even relatively low concentrations of MMP-3 (1:200) resulted in digests that failed to react with these antibodies on immunoblotting. This result means that A $\alpha$ 349-406 has been cleaved from fibrin by MMP-3. No immunoreactivity with MoAb/1D4 in MMP-3-digests of XL-Fb could be detected by competition ELISA. This antibody reacts identically with A $\alpha$ 349-406 and Hi2-DSK (A $\alpha$ 241-476) before and after complete digestion with trypsin.

25

#### EXAMPLE 6

30

**[0110]** *Digestion of Fragment D-Dimer (DD) by MMP-3.* Experiments were carried out to see whether MMP-3 would cleave purified D-dimer (DD) into D monomer. Purified fragment D and D-dimer were incubated 37 °C for 4 and 24 hours with lower (1:20) and higher (1:200) concentration of MMP-3. The reactions were terminated with 25 mM EDTA. The digests were resolved on PAGE (7% phosphate). The samples were transferred to nitrocellulose membranes and stained with Coomassie blue. The results are shown in Figure 6. Samples were run under non-reducing (Fig. 6A) and reducing (Fig. 6B) conditions. The key to Figures 6A and 6B is as follows:

35

Lane No.	Sample
1	Plasmin digested Fg (D monomer 93 kDa)
2	Plasmin digested XL-Fb (D dimer 186 kDa)
3	MMP-3 digest (1:200) of purified D dimer (4 hr)
4	MMP-3 digest (1:20) of purified D dimer (4 hr)
5	MMP-3 digest (1:20) of purified D dimer (24 hr)

40

45

50

**[0111]** As shown in Figures 6A and 6B, progressive (time-dependent) degradation of D dimer (186 kDa) into D monomer-like fragment (lanes 4, 5). The size of the resulting monomer was slightly larger than Fragment D (93 kDa), obtained during plasmin degradation of Fg (lane 1). Also, as this gel was made 2 months after preparation of these samples, this proves that the reaction has been stopped effectively and has not progressed any further. The results indicate that monomerization occur even at 4 hours with the lower amount of enzyme (1:200) (lane 3). Increasing the amount of enzyme ten-fold increases the monomerization at 4 hours (lane 4) and almost completely converts the substrate at 24 hours (lane 5). This is supported in Fig. 6B, which shows the conversion of  $\gamma$  dimer (78 kDa) to  $\gamma$  monomer-like chain (38 kDa).

55

#### EXAMPLE 7

**[0112]** *Analysis of MMP Digestion Products by ELISA.* ELISA binding assays were performed using generally accepted methods. Polyvinyl microtiter plates were coated with appropriate dilutions of different digests and assayed

for antibody binding (Kudryk et al. 1984). In accord with the results shown in Figure 4, digests with increasing concentrations of MMP-3 failed to bind MoAb/4A5 (anti- $\gamma$ 397-411). This means that the fibrinogen cleavage site of MMP-3 is in the region of this epitope (the fibrin cross-links occur in the region  $\gamma$ Gly397-Lys406). This type of cleavage does not occur with plasmin. However, the digests were found to be reactive with MoAb/4-2 ( $\gamma$ 349-406). No immunoreactivity with MoAb/1D4 in MMP-3 digests of XL-Fb could be detected by competition ELISA, suggesting that the 1D4-reactive epitope is destroyed in such digests. MoAb/1D4 binds equally to plasmin digests of Fg and XL-Fb.

[0113] Thus, the ELISA (direct binding) performed on digests of Fg and XL-Fb with MMP-3 showed that the linear sequence epitope  $\gamma$ 392-406 (MoAb/4-2-reactive), but not  $\gamma$ 397-411 (MoAb/4A5-reactive), could be detected by this method. This confirmed the results obtained with immunoblotting and further suggested that MMP-3 cleaves within the sequence  $\gamma$ 397-411. NH<sub>2</sub>-terminal sequence analysis of the dipeptide (isolated from CNBr degradation of XL-fibrin digested with MMP-3) indicated that  $\gamma$ Ala405 is the first residue of the second sequence (See Examples 8-9, below). We note that MoAb/4-2 also binds a synthetic peptide whose sequence corresponds to  $\gamma$ 392-400. MoAb/4A5 reacts with synthetic peptides corresponding to  $\gamma$ 392-411 and  $\gamma$ 397-411, which is lost when either peptide is cleaved with trypsin at  $\gamma$ Lys406-Gln407. This feature is consistent with the observed lack of reactivity of MoAb/4A5 with the dipeptide.

#### EXAMPLE 8

[0114] *Size and Sequence Analysis of Chains of MMP-3-Digested Fg and XL-Fb.* Fg and XL-Fb digested with MMP-3 were separated under reducing conditions on a 12.5% SDS-PAGE (Laemmli 1970) and electroblotted to a polyvinylidene difluoride membrane (PVDF) (Matsudaira 1987). The portion of the membrane that contained the  $\gamma$ -chain fragment was excised and subjected to automated sequencing on a model 477A Applied Biosystems Inc. pulsed liquid phase sequencer with a model 120A on-line phenylthiohydantoin (PTH) amino acid analyzer.

[0115] The digests of both Fg and XL-Fb yielded a  $\gamma$ -chain sequence Leu-Lys-Ser-Arg-Lys (SEQ ID NO:1), indicating that MMP-3 cleaves both Fg and XL-Fb at the  $\gamma$ Thr83-Leu84 bond. This same band from the XL-Fb digest, however, also gave a second  $\gamma$ -chain sequence Ala-X-Gln-Ala-Gly-Asp (SEQ ID NO:2) indicating MMP-3-induced hydrolysis at the  $\gamma$ Gly404-Ala405 bond, in the  $\gamma$ -chain cross-link region.

#### EXAMPLE 9

[0116] *Characterization of a CNBr-derived  $\gamma$ -chain fragment from MMP-3-digests of XL-Fb.* To confirm the results obtained from sequencing the  $\gamma$ -chain of XL-Fb degraded with MMP-3, the same digest was treated with CNBr (Blombäck et al. 1968) and the fragment reactive with MoAb/4-2 (anti- $\gamma$ 392-406) was isolated, as follows. MMP-3-cleaved fragments were purified by reverse-phase HPLC using a Vydac C-4 column (1.0 x 25 cm, The Sep/a/rations Group, Hesperia, CA). The column was developed at room temperature using the following gradient constructed with 0.05% trifluoroacetic acid (TFA, solvent A) and 50% acetonitrile in A (solvent B): at 5% B/0.5 min; 5 to 50% B/at 50 min; 50 to 100% B/at 70 min; 100% B/at 75 min. Column flow rate was 1.0 mL/min and fractions (1 mL) were monitored for reactivity with MoAb/4-2 (anti- $\gamma$ 392-406). The antibody-reactive fraction was further purified by FPLC using the Superdex Peptide HR 10/30 column (1.0 x 30-31 cm, Pharmacia Biotech, Piscataway, NJ). The column was developed at room temperature using 20 mM phosphate buffer (pH 7.2), additionally containing 0.25 M NaCl. The fraction reacting with MoAb/4-2 was pooled, desalted by passage over Sep-Pak<sup>®</sup> (Millipore Corp., Milford, MA) and subjected to sequence analysis.

[0117] The sequenced fragment corresponded to a cross-linked dipeptide with two distinct NH<sub>2</sub>-terminals:  $\gamma$ Lys385, resulting from CNBr cleavage, and  $\gamma$ Ala405 (Figure 7). The two sequences were recovered in comparable molar quantities. In cycle 3 NH<sub>2</sub>-terminal analyses showed no PTH residues (due to a machine error), but evidence for Gln and Ile in cycle 3 was seen in cycle 4 as lag. These data support our conclusion that MMP-3 cleaves at  $\gamma$ Gly404-Ala405 within the cross-link region of fibrin  $\gamma$ -chain.

[0118] Table III shows the partial sequence for the cross-linked dipeptide isolated from XL-Fb digested with MMP-3 after CNBr degradation. The  $\gamma$  cross-linking domain, with the sites of MMP-3 digestion and CNBr cleavage, is shown schematically in Figure 7. The resulting dipeptide contains a single  $\epsilon$ -( $\gamma$ -Glu)-Lys bond, with one NH<sub>2</sub>-terminal as  $\gamma$ Lys385, resulting from CNBr cleavage at  $\gamma$ Met384-Lys385. The presence of the second NH<sub>2</sub>-terminal,  $\gamma$ Ala405, supported our conclusion that MMP-3 cleaves at  $\gamma$ Gly404-Ala405 in the cross-link region of the  $\gamma$ -chain.

TABLE III

Cycle	PTH Amino Acid / Yield (pmol)	
1	K (215)	A (673)
2	I (648)	---
3	I*	Q*
4	P (406)	A (438)
5	F (352)	G (565)
6	N (219)	D (202)
7	R (200)	V (115)
8	L (313)	---
9	T (179)	---
10	I (349)	---

5  
10  
15  
20

**[0119]** Data obtained from sequence analysis of MMP-3 digests of Fg and XL-Fb showed proximity of cleavage sites with plasmin on these same substrates. Plasmin cleaves at  $\gamma$ Lys62-Ala63 and more slowly at  $\gamma$ Lys85-Ser86 (Colten et al. 1975). Thus, fibrinogen digested by plasmin results in two Fragment D species, i.e.,  $\gamma$ Ala63-Val411 and  $\gamma$ Ser86-Val411. By contrast, MMP-3 cleaves both Fg and XL-Fb at  $\gamma$ Thr83-Leu84. In addition, since MMP-3 hydrolyzes the  $\gamma$ Gly404-Ala405 peptide bond, the  $\gamma$ -chain has a molecular weight that is substantially similar to that of plasmin-generated Fragment D  $\gamma$ -chain. However, in the digests of XL-Fb with MMP-3, this product is not a real monomer since the  $\gamma$ 405-411 domain is cross-linked to the adjacent  $\gamma$ -chain having the sequence  $\gamma$ Leu84-Gly404. It should be noted that the recovery of similar quantities of the two sequences from the  $\gamma$ -chains of the CNBr-generated dipeptide indicated that, albeit slow, the degradation of XL-Fb by MMP-3, resulting in formation of the D monomer-like fragment, was near complete.

#### EXAMPLE 10

**[0120]** *Characterization of Other Cleavage Products of Fg and XL-Fb by MMP-3.* MMP-3 also generates other cleavage products of Fg and XL-Fb, specifically cutting not only the  $\gamma$ -chain, but also the  $\alpha$ - and  $\beta$ -chains. Fg and XL-Fb were digested using MMP-3 (E:S = 1:20) for 24 hr, separated, and sequenced using the methods described in Example 9. As indicated in Figure 8, both Fg (lane 1) and XL-Fb (lane 2) were specifically cleaved. In Figure 8, band 1 was found to include two fragments: a  $\gamma$ -chain fragment having an NH<sub>2</sub>-terminal sequence of Leu-Lys-Ser-Arg-Lys (SEQ ID NO:1), again corresponding to cleavage  $\gamma$ 84; and a  $\beta$ -chain fragment ( $\beta_1$ ) having an NH<sub>2</sub>-terminal sequence Lys-Arg-Gln-Lys-Gln (SEQ ID NO:3) corresponding to cleavage at  $\beta$ 127. Band 2 was found to contain another  $\beta$ -chain fragment ( $\beta_2$ ) having the NH<sub>2</sub>-terminal sequence Tyr-Ser-Ser-Glu-Leu (SEQ ID NO:4), corresponding to cleavage at  $\beta$ 142. Band 3 is the enzyme MMP-3 remaining in the digest preparation. Band 4 was found to contain an  $\alpha$ -chain fragment having an NH<sub>2</sub>-terminal sequence Asn-Arg-Asp-Asn-Thr (SEQ ID NO:5), corresponding to cleavage at  $\alpha$ 103. (Band 4 was also found to contain fragments cleaved at  $\gamma$ 1 and  $\alpha$ 414 in both fibrinogen and fibrin digests.) Band 5 contained fragments cleaved at  $\beta$ 51 and  $\beta$ 52 in both fibrin and fibrinogen digests with MMP-3.

**[0121]** Accordingly, the evidence presented in Examples 1-10, above, establishes that fibrinogen becomes thrombin-unclootable when treated with matrix metalloproteinase 3 (MMP-3, stromelysin-1), but not when treated with matrix metalloproteinase 2 (MMP-2, gelatinase A). Incubation of XL-Fb clots (made with <sup>125</sup>I-Fg) with MMP-3 results in complete lysis after 24 hrs. A D monomer-like fragment is generated by MMP-3 degradation of fibrinogen, XL-Fb and Fragment DD. Immunoreactivity with monoclonal antibody MoAb/4-2 (anti- $\gamma$ 392-406), but not with MoAb/4A5 (anti- $\gamma$ 397-411), suggested that a major cleavage site was within the sequence participating in the cross-linking of two  $\gamma$ -chains. NH<sub>2</sub>-terminal sequence of the  $\gamma$ -chain of the D monomer-like fragment and of a dipeptide isolated from the MMP-3 digest of XL-fibrin, identified the hydrolysis of  $\gamma$ Gly404-Ala405 peptide bond. These data indicate that the degradation of Fg and XL-Fb by MMP-3 is specific and different from plasmin. This mechanism of fibrinolysis is of relevance in wound healing, inflammation, atherosclerosis, malignancy, renal disease, and other pathophysiological processes.

**[0122]** Inasmuch as MMP-3 cleaves near the site at which fibrin cross-linking occurs, a strong teleological argument is readily made that MMP-3 plays a singular role in fibrinolysis. Coordinated regulation of the metalloproteinases

and plasminogen activators could, therefore, result in synergistic effects and complete degradation of both the extracellular matrix and the fibrin meshwork resulting from wound healing, inflammation, thrombosis, cancer, renal disease, or other pathophysiological processes. Accordingly, it is contemplated that the co-administration of MMP-3 with another thrombolytic agent such as t-PA would also achieve an adjuvant therapeutic effect, in which each component complements or potentiates the other.

#### EXAMPLE 11

**[0123]** Fibrinogen and cross-linked fibrin were degraded by matrix metalloproteinase 7 (MMP-7; matrilysin; PUMP-1) using a method substantially according to that described in Example 1. Briefly, fibrinogen (Fg) (120  $\mu$ g, 3.5  $\mu$ M) was incubated with MMP-7, MMP-9 or MMP-3 (6  $\mu$ g corresponding to 1.3  $\mu$ M 1:20, E:S ratio) at 37°C for different time intervals. Pro-MMP-7 and pro-MMP-3 (in 50 mM Tris-HCl, pH 7.5, 0.15 M NaCl, 0.05% Brij 35, 0.05% NaN<sub>3</sub>) were activated with 1 mM APMA at 37°C for 1 hr and 45 min respectively, prior to addition to Fg solutions. MMP-9 was activated at 40°C for 1 hr in the same experimental conditions. All reactions were in the presence of 10 mM CaCl<sub>2</sub> at 37°C. Digestions were terminated by addition of EDTA (25 mM final concentration). Cross-linked fibrin clots were made with 0.1 mL purified Fg (1.2 mg/mL in TNE buffer) in the presence of 20 mM CaCl<sub>2</sub>. Thrombin (1.5 NIH U/mL, final concentration) was added and samples were incubated at 37°C/18-20 hrs. Active MMP-7, MMP-9 and MMP-3 were added in amount (6  $\mu$ g) corresponding to 1:20 E:S ratio in the presence of 10 mM CaCl<sub>2</sub>. Clots were gently dislodged from the wall of the test tube with a wooden stick and the content lightly vortexed after addition of each enzyme. Incubation times were from 1-48 hrs at 37°C.

**[0124]** Samples from digestion of fibrinogen and cross-linked fibrin with MMP-7, MMP-9 and MMP-3 were subjected to SDS-PAGE using both reducing and non-reducing conditions, generally as described above, using 7.5% or 12.5% polyacrylamide gels in the Tris-glycine buffer. Detection of separations was accomplished using the described method. The results of these experiments are shown in Figures 9 and 10.

**[0125]** Figure 9 illustrates the chain composition of Fibrinogen and XL-Fb degraded with MMP-7, MMP-3 and MMP-9. All enzymes were used at E:S = 1:20 (w/w) and incubated for different time intervals at 37°C, as indicated. Digests with MMPs were terminated with EDTA (25 mM final concentration). The digests were reduced and separated by SDS-PAGE (12.5%). Samples of Fg digested with the indicated enzymes were as follows: (lanes 2-5) MMP-7; (lanes 11) MMP-3. Samples of digested XL-Fb were as follows: (lanes 6-9) MMP-7; (lanes 12 and 13) MMP-3; (lanes 14-16) MMP-9. The gel was stained for protein with Coomassie Blue.

**[0126]** As shown in Figure 9, fibrinogen degraded with MMP-7 (lanes 2-5) shows progressive degradation of all chains as compared with intact fibrinogen in lane 1. Cross-linked fibrin (lanes 6-9) is also progressively degraded by MMP-7. The complete digests at both 24 and 48 hours, that were completely soluble, show presence of  $\gamma$ - $\gamma$  chains, however with a molecular weight lower than intact  $\gamma$ -dimer. This signifies that the amino terminus of the cross-linked fibrin  $\gamma$ - $\gamma$  has been degraded but the carboxy terminus is still cross-linked. The pattern of the reduced  $\beta$  and  $\gamma$  chains of fibrinogen degraded by MMP-7 (Lanes 4 and 5) seem similar to those obtained by MMP-3 (lanes 12 and 13). However, cross-linked fibrin degraded by MMP-7 only show the  $\beta$  chain at corresponding molecular weight since the  $\gamma$ - $\gamma$  is still cross-linked. MMP-9 does not seem to degrade cross-linked fibrin and the pattern looks identical to intact cross-linked fibrin (lanes 14-16).

**[0127]** Figure 10 illustrates MMP-7 and MMP-3 degradation of XL-Fb  $\gamma$ -chain dimers. Samples were subjected to SDS-PAGE (12.5% gels) under reducing conditions. The samples were exactly as those shown in Figure 9. The membrane was transferred to nitrocellulose and blotted with MoAb/4A5 (anti- $\gamma$  397-411). Specific antibody-bound fibrin(ogen) chains were detected using RAM-HRPO and chemiluminescent substrate. The results obtained with this antibody confirmed and extended the results obtained with the gel stained with Coomassie Blue. Fibrinogen  $\gamma$  chain was degraded by MMP-7, but did not lose immunoreactivity with MoAb/4A5, contrary to fibrinogen  $\gamma$  chain degraded with MMP-3 (lane 11). Cross-linked fibrin  $\gamma$ -dimer (lanes 6-8) retains immunoreactivity after degradation with MMP-7. Fibrinogen and cross-linked fibrin digests with MMP-3 (lanes 11-13) do not show any reactivity with MoAb/4A5, as previously found, since MMP-3 cleaves the reactive epitope at  $\gamma$  Gly404-Ala405. Cross-linked fibrin exposed to MMP-9 retains full immunoreactivity since the enzyme does not seem to have any proteolytic (i.e., fibrinolytic) activity. Fibrinogen was similarly resistant to cleavage by MMP-9 (data not shown).

**[0128]** MMP-7 is expressed in a number of cells including bone marrow-derived promonocytes and peripheral blood monocytes. MMP-7 has strong proteolytic activity and digests aggrecan, fibronectin and elastin (reviewed in Nagase 1996). Studies in progress have indicated the presence of MMP-7 in atherosclerotic plaques. As shown by our data, MMP-7 has a strong proteolytic action on the degradation of fibrinogen and has the ability to lyse and solubilize cross-linked fibrin clots. However, its mechanism of action is different from that of MMP-3. MMP-3 degrades cross-linked  $\gamma$ -chains, but MMP-7 seems to generate fibrin(ogen) degradation products with a pattern similar to that obtained with plasmin degradation. Specifically, the clot is degraded, but the  $\gamma$ - $\gamma$  cross-link remains intact. On reduced gels both fibrinogen and fibrin  $\gamma$ -chains show similar degradation patterns. The actual cleavage site is not yet known.

## EXAMPLE 12

**[0129]** Fibrinogen and cross-linked fibrin were degraded by MT1-MMP and MT2-MMP using a method substantially according to that described in Example 1. Briefly, fibrinogen (Fg) (120  $\mu\text{g}$ , 3.5  $\mu\text{M}$ ) was incubated with MT1-MMP or MT2-MMP (5  $\mu\text{g}$  corresponding to 1.3  $\mu\text{M}$  1:24, E:S ratio) at 37°C for different time intervals. All reactions were in the presence of 10 mM  $\text{CaCl}_2$  at 37°C. Digestions were terminated by addition of EDTA (25 mM final concentration). Cross-linked fibrin clots were made with 0.1 mL purified Fg (1.2 mg/mL in TNE buffer) in the presence of 20 mM  $\text{CaCl}_2$ . Thrombin (1.5 NIH U/mL, final concentration) was added and samples were incubated at 37°C/18-20 hrs. Active MT1-MMP and MT2-MMP were added in amount (5  $\mu\text{g}$ ) corresponding to 1:24 E:S ratio in the presence of 10 mM  $\text{CaCl}_2$ . Clots were gently dislodged from the wall of the test tube with a wooden stick and the content lightly vortexed after addition of each enzyme. Incubation times were from 1-48 hrs at 37°C.

**[0130]** Samples from digestion of fibrinogen and cross-linked fibrin with MT1-MMP and MT2-MMP were subjected to SDS-PAGE using both reducing and non-reducing conditions, generally as described above, using 7.5% or 12.5% polyacrylamide gels in the Tris-glycine buffer. Detection of separations was accomplished using the described method.

**[0131]** The following samples were reduced and separated by SDS-PAGE (5-15% gradient gel): Fg (lane 1); XL-Fb degraded with MT1-MMP (1:24 w/w) for 24H (lane 2); XL-Fb (lane 3); XL-Fb degraded with MT2-MMP (1:24 w/w) for 24h (lane 4); Protein Standards (lane 5). Protein was stained with Coomassie Blue.

**[0132]** MT1-MMP completely lyses XL-Fb, maintaining cross-linked  $\gamma$  chains (lane 2), similarly to plasmin-degraded cross-linked fibrin, while MT2-MMP leads to only partial degradation and the clot is not solubilized under comparable time and experimental conditions (lane 4, compare with XL-Fb, lane 3). Therefore, MT1-MMP degrades Fg (not shown) and solubilize XL-Fb while MT2-MMP leads to only partial degradation.

## EXAMPLE 13

**[0133]** Fibrinogen and cross-linked fibrin were degraded by MMP-3, MMP-7 and MT1-MMP (in Tables IV, V, and VI below) using a method substantially according to that described in Example 1. Briefly, fibrinogen (Fg) (120  $\mu\text{g}$ , 3.5  $\mu\text{M}$ ) was incubated with MMP-3, MMP-7 or MT1-MMP (5  $\mu\text{g}$  corresponding to 1.3  $\mu\text{M}$  1:24, E:S ratio) at 37°C for different time intervals. Pro-MMP-3, pro-MMP-7, and pro-MT1-MMP (in 50 mM Tris-HCl, pH 7.5, 0.15 M NaCl, 0.05% Brij 35, 0.05%  $\text{NaN}_3$ ) were activated with 1 mM APMA at 37°C for 1 hr and 45 min respectively, prior to addition to Fg solutions. All reactions were in the presence of 10 mM  $\text{CaCl}_2$  at 37°C. Digestions were terminated by addition of EDTA (25 mM final concentration). Cross-linked fibrin clots were made with 0.1 mL purified Fg (1.2 mg/mL in TNE buffer) in the presence of 20 mM  $\text{CaCl}_2$ . Thrombin (1.5 NIH U/mL, final concentration) was added and samples were incubated at 37°C/18-20 hrs. Active MMP-3, MMP-7 and MT1-MMP were added in amount (5  $\mu\text{g}$ ) corresponding to 1:24 E:S ratio in the presence of 10 mM  $\text{CaCl}_2$ . Clots were gently dislodged from the wall of the test tube with a wooden stick and the content lightly vortexed after addition of each enzyme. Incubation times were from 1-48 hrs at 37°C.

**[0134]** Samples from digestion of fibrinogen and cross-linked fibrin with MMP-3, MMP-7 and MT1-MMP were subjected to SDS-PAGE using both reducing and non-reducing conditions, generally as described above, using 7.5% or 12.5% polyacrylamide gels in the Tris-glycine buffer. Detection of separations was accomplished using the described method. The results of these experiments are shown in Tables IV-VII.

**[0135]** Tables IV-VII illustrate the completed the amino terminal sequence of the fragments obtained after cross-linked fibrin degradation with MMP-3, MMP-7 and MT1-MMP. The molecular mass of the fragments was calculated by scanning using Gel-Pro analyzer software. The similarity of the cleavage sites obtained on XL-Fb with MM-3, -7 and MT1-MMP, but not with MMP-1, -2, -9 and MT2-MMP, demonstrate that selected MMPs can achieve cleavage sites obtained on XL-Fb.

**[0136]** Degradation of fibrinogen and cross-linked fibrin by plasmin, the main fibrinolytic enzyme results in formation of Fragments D and D-dimer. Their cleavage sites are:  $\alpha$  Arg 104-Asp 105,  $\beta$  Lys 133-Asp 134,  $\gamma$  Lys 62-Ala 63 and  $\gamma$  Lys 85-Ser 86 (4). Analysis of D/D-dimer  $\alpha$ -chain, obtained on the same substrates by MMP-3, -7 and MT1-MMP showed cleavage at  $\alpha$  Asn 102-Asn 103 and  $\alpha$  Asp 97-Phe 98, respectively. MMP-3, -7 and MT1-MMP degradation of the  $\beta$ -chain resulted in microheterogeneity of cleavage sites, namely  $\beta$  Leu 120-Leu 121,  $\beta$  Gln 126-Lys 127,  $\beta$  Asn 137-Val 138 and  $\beta$  Glu 141-Tyr 142. MMP-3, -7 and MT1-MMP all cleave  $\gamma$ -chain at  $\gamma$  Thr 83-Leu 84 (Table VII). The fact that plasmin and MMPs cleavage sites in fibrinogen and cross-linked fibrin are in close proximity can be explained by susceptibility to proteolysis of the fibrin(ogen) molecule in selected and exposed areas.

**[0137]** In summary, our studies show that MMP-3, -7 and MT1-MMP are capable of fully solubilize XL-Fb while the other MMPs tested did not.

**[0138]** Thus, while there have been described what are presently believed to be the preferred embodiments of the present invention, those skilled in the art will realize that other and further embodiments can be made without departing from the spirit of the invention, and it is intended to include all such further modifications and changes as come within the true scope of the claims set forth herein.

Table IV: NH<sub>2</sub>-Terminal Amino Acid Sequence Analysis of XL-Fb degraded with MMP-3 (Enzyme/Substrate Ratio 1/20) for 24 h at 37°C

Fragment	amino acid (recovery in pmol) in cycle							
	1	2	3	4	5	6	7	8
88 kDa	γ-84 Leu (1)	Lys (1)	Ser (1)	Arg (0.5)	Lys (1)	Met (1)	Leu (0.5)	Glu (0.2)
40 kDa	γ-84 Leu (10)	Lys (10)	Ser (10)	Arg (5)	Lys (4)	Met (5)	Leu (4)	Glu (-)
	β-121 Leu (5)	Lys (4)	Asp (4)	Leu (2)	Trp (1)	Gln (5)	Lys (2)	Arg (1)
	γ-405 Ala (7)	Lys (*)	Gln (4)	Ala (3)	Gly (1)	Asp (-)	Val (-)	-
38 kDa	β-127 Lys (4)	Arg (4)	Gln (2)	Lys (3)	Gln (7)	Val (2)	Lys (1)	Asp (2)
	γ-84 Leu (4)	Lys (5)	Ser (2)	Arg (2)	Lys (2)	Met (2)	Leu (2)	Glu (5)
36kDa	β-142 Tyr (5)	Ser (1)	Ser (1)	Glu (1)	Leu (3)	Glu (1)	Lys (2)	His (1)
14kDa	γ-1 Tyr (4)	Val (6)	Ala (3)	Thr (3)	Arg (3)	Asp (2)	Asn (-)	Cys (-)
	α-103 Asn (11)	Arg (15)	Asp (7)	Asn (9)	Thr (3)	Tyr (8)	Asn (4)	Arg (6)
12.5kDa	γ-1 Tyr (12)	Val (17)	Ala (10)	Thr (6)	Arg (8)	Asp (3)	Asn (5)	Cys (-)
	α-103 Asn (1)	Arg (1)	Asp (1)	Asn (1)	Thr (?)	Tyr (0.5)	Asn (-)	Arg (0.5)
	α-414 Leu (3)	Val (7)	Thr (0.2)	Ser (0.2)	Lys (1)	Gly (1)	Asp (2)	Lys (1)
12kDa	α-17 Gly (12)	Pro (8)	Arg (6)	Val (8)	Val (15)	Glu (12)	Arg (9)	His (4)
	β-51 Thr (5.5)	Gln (9)	Lys (10)	Lys (6)	Val (-)	Glu (?)	Arg (-)	Lys (-)
	α-20 Val (6)	Val (7)	Glu (3)	Arg (5)	Ileis (2.5)	Gln (2)	Ser (3)	Ala (5)
	β-52 Gln (4)	Lys (5)	Lys (-)	Val (-)	Glu (1)	Arg (1)	Lys (1)	Ala (-)

XL-Fb: cross-linked fibrin

\* Present as crosslink

(-) Recovery undetectable

Table V: NH<sub>2</sub>- Terminal Amino Acid Sequence Analysis of XL-Fb degraded with MMP-7 (Enzyme/Substrate Ratio 1/20) for 24 h at 37°C

Fragment	amino acid (recovery in pmol) in cycle							
	1	2	3	4	5	6	7	8
90 kDa	γ-84 Leu (3)	Lys (2)	Ser (1)	Arg (0.5)	Lys (1)	Met (1)	Leu (1)	Glu (0.5)
82 kDa	γ-84 Leu (15)	Lys (13)	Ser (1)	Arg (8)	Lys (9)	Met (6)	Leu (8)	Glu (1)
38 kDa	β-124 Leu (15)	Trp (8)	Gln (7)	Lys (11)	Arg (7)	Gln (6)	Lys (10)	Gln (6)
36 kDa	β-142 Tyr (2)	Ser (1)	Ser (1)	Glu (1)	Leu (1)	Glu (1)	Lys (0.5)	His (0.5)
14 kDa	α-98 Phe (16)	Ser (2)	Ser (2)	Ala (8)	Asn (5)	Asn (6)	Arg (7)	Asp (1)
12.5 kDa	γ-1 Leu (9)	Val (18) Arg (5)	Ala (17) Thr (1)	Thr (5) Gly (3)	Arg (10) Lys (3)	Asp (6) Glu (0)	Asn (5) Lys (4)	Cys (-) Val (3)
12 kDa	α-17 Val (4)	Pro (10) Val (5)	Arg (11) Glu (4)	Val (6) Arg (0)	Val (10) His (1)	Glu (5) Gln (2)	Arg (6) Ser (3)	His (6) Ala (3)

XL-Fb: crosslinked fibrin  
(-) Recovery undetectable

Table VI: NH<sub>2</sub>-Terminal Amino Acid Sequence Analysis of XL-Fb degraded with MTI-MMP (Enzyme/Substrate Ratio 1/20) for 24 h at 37°C

Fragment	amino acid (recovery in pmol) in cycle								
	1	2	3	4	5	6	7	8	
88kDa	γ-84	Leu (4)	Lys (4)	Ser (0.8)	Arg (3)	Lys (2)	Met (2)	Leu (2)	Glu (1)
	γ-79	Ile (2)	Asp (3)	Ala (1)	Ala (1)	Thr (1)	Leu (1)	Lys (1)	Ser (0.2)
	γ-1	Tyr (2)	Val (1)	Ala (1)	Thr (0.5)	Arg (2)	Asp (2)	Asn (1)	Cys (-)
81kDa	γ-84	Leu (10)	Lys (10)	Ser (3)	Arg (6)	Lys (5)	Met (6)	Leu (4)	Glu (2)
	γ-79	Ile (3)	Asp (5)	Ala (1)	Ala (1)	Thr (2)	Leu (2)	Lys (1)	Ser (0.3)
52 kDa	β-15	Gly (2)	His (1)	Arg (2)	Pro (1)	Leu (1)	Asp (1)	Lys (0.4)	Lys (1)
49kDa	β-51	Thr (2)	Gln (2)	Lys (1)	Lys (1)	Val (1)	Glu (1)	Arg (1)	Lys (0.7)
38kDa	β-124	Leu (7)	Trp (3)	Gln (5)	Lys (5)	Arg (6)	Gln (6)	Lys (3)	Gln (2)
36kDa	β-138	Val (4)	Val (4)	Asn (2)	Glu (3)	Tyr (3)	Ser (4)	Ser (4)	Glu (1)
	β-142	Tyr (1)	Ser (0.3)	Ser (0.4)	Glu (0.5)	Leu (1)	Glu (1)	Lys (1)	His (0.5)
14kD	β-15	Gly (2)	His (0.7)	Arg (1)	Pro (0.5)	Leu (1)	Asp (2)	Lys (0.5)	Lys (1)
12.5kDa	α-98	Phe (19)	Ser (1)	Ser (2)	Ala (8)	Asn (7)	Asn (9)	Arg (9)	Asp (3)
	α-103	Asn (6)	Arg (5)	Asp (4)	Asn (2)	Thr (0.6)	Tyr (2)	Asn (1)	Arg (4)
	α-414	Leu (6)	Val (3)	Thr (0.8)	Ser (1)	Lys (1)	Gly (2)	Asp (3)	Lys (2)
	β-51	Thr (3)	Gln (3)	Lys (1)	Lys (1)	Val (1)	Glu (2)	Arg (-)	Lys (2)
	γ-1	Tyr (2)	Val (1)	Ala (1)	Thr (-)	Arg (0.4)	Asp (0.6)	Asn (0.5)	Cys (-)
12kDa	α-17	Gly (36)	Pro (12)	Arg (18)	Val (12)	Val (18)	Glu (7)	Arg (12)	His (10)

XL-Fb: cross-linked fibrin  
 (-) Recovery undetectable

TABLE VII

PEPTIDE BONDS CLEAVED BY MMP-3, MMP-7 AND IN GENERATION OF FRAGMENTS D/DD. COMPARISON WITH				
CHAIN*	AMINO ACID SEQUENCE			
D/DD	MMP-3	MMP-7	MT1-MMP	PLASMIN
$\alpha$	Asn <sup>102</sup> -Asn <sup>103</sup>	Asp <sup>97</sup> -Phe <sup>98</sup>	Asp <sup>97</sup> -Phe <sup>98</sup>	<b>Arg<sup>104</sup></b>
$\beta$ 1	Leu <sup>120</sup> -Leu <sup>121</sup>	Asp <sup>123</sup> -Leu <sup>124</sup>	Asp <sup>123</sup> -Leu <sup>124</sup>	Lys <sup>133</sup> -Asp <sup>134</sup>
$\beta$ 2	Glu <sup>141</sup> -Thr <sup>142</sup>	Glu <sup>141</sup> -Thr <sup>142</sup>	Asn <sup>137</sup> -Val <sup>138</sup>	-
$\beta$ 3	Gln <sup>126</sup> -Lys <sup>127</sup>	Asn <sup>137</sup> -Val <sup>138</sup>	Glu <sup>141</sup> -Thr <sup>142</sup>	-
$\beta$ 4	Asn <sup>137</sup> -Val <sup>138</sup>	Leu <sup>120</sup> -Leu <sup>121</sup>	-	-
$\gamma$ 1	Thr <sup>83</sup> -Leu <sup>84</sup>	Thr <sup>83</sup> -Leu <sup>84</sup>	Thr <sup>83</sup> -Leu <sup>84</sup>	Lys <sup>62</sup> -Ala <sup>63</sup>
$\gamma$ 2	-	-	-	Lys <sup>85</sup> -Ser <sup>86</sup>

\*Chain designation is based on relative mobility on SDS-PAGE, the lower corresponds to the larger chain remnant

## BIBLIOGRAPHY

[0139] The following publications have been mentioned in the foregoing specification, and are incorporated herein by reference for all that they disclose:

Bilezikian, SB, and HL Nossel, *Blood* 50:21-28 (1977).

Bini, A, JJ Fenoglio Jr, J Sobel, J Owen, M Fejgl, and KL Kaplan, *Blood* 69:1038-1045 (1987).

Bini, A, JJ Fenoglio Jr, R Mesa-Tejada, B Kudryk, and KL Kaplan, *Arteriosclerosis* 9:109-121 (1989).

Bini, A, S Callender, R Procyk, B Blombäck, and BJ Kudryk, "Flow and antibody binding properties of hydrated fibrins prepared from plasma, platelet rich plasma and whole blood," *Thrombosis Res* 76:145-56 (1994).

Bini, A., Y. Itoh, B. J. Kudryk, and H. Nagase. "Degradation of cross-linked fibrin by matrix metalloproteinase 3 (Stromelysin 1): hydrolysis of the g Gly 404 - Ala 405 peptide bond," *Biochemistry* 35: 13056-13063, 1996.

Bini, A., B.J. Kudryk, and J. Schnuer. "Characterization of fragments D-dimer and D-like monomer obtained by degradation of cross-linked fibrin and matrix metalloproteinase (MMP)-7 (Matrilysin) and MMP-3 (stromelysin 1), *Blood* 90: 464a, 1997.

Blombäck, B, M Blombäck, A Henschen, B Hessel, S Iwanaga, and KR Woods, *Nature* 218:130-134 (1968).

Blombäck, B, and M Okada, *Thromb Res* 25:51-70 (1982).

Blombäck, B, K Carlsson, K Fatah, B Hessel, and R Procyk, *Thromb Res* 75:521-538 (1994).

Brakman, P, and C Kluft, eds., *Plasminogen Activation in Fibrinolysis, in Tissue Remodeling, and in Development*, *Ann NY Acad Sci*, vol. 667 (1992).

Budzynski, AZ, "Interaction of hementin with fibrinogen and fibrin," *Blood Coagulation and Fibrinolysis* 2:149-52 (1991).

Campbell, EJ, JD Cury, SD Shapiro, GI Goldberg, and HG Welgus, *J Immunol* 146:1286-1293 (1991).

Cawston, T, "Metalloproteinase inhibitors--Crystal gazing for a future therapy," *Br J Rheumatol* 30:242-44 (1991).

Chen, R, and RF Doolittle, *Biochemistry* 10:4486-4491 (1971).

Collen, D, B Kudryk, B Hessel, and B Blombäck, *J Biol Chem* 250:5808-5817 (1975).

Collen, D, "On the regulation and control of fibrinolysis," *Thromb Haemost* 43:77-89 (1980).

Collen, D, "Biological properties of plasminogen activators," Chapter 1 in Sobel BE, Collen, D, and EB Grossbard, eds., *Tissue Plasminogen Activator in Thrombolytic Therapy*, Marcel Dekker, Inc., New York (1987).

Collen, D, and HR Lijnen, "Basic and clinical aspects of fibrinolysis and thrombolysis," *Blood* 3114-24 (1991).

Collen, D, "Fibrin-selective thrombolytic therapy for acute myocardial infarction," *Circulation* 93:857-865 (1996).

D'Ortho, M-P, Stanton, Heather, Butler, Michael, Atkinson, Susan J., Murphy, Gillian, and Hembry, Rosalind M., "MT1-MMP on the cell surface causes focal degradation of gelatin films," *FEBS Letters*, 421:159-164 (1998).

D'Ortho, M-P, Will H, Atkinson S, Butler G, Messent A, Gavrilovic J, Smith B, Timpl R, Zardi L, Murphy G., "Membrane-type matrix metalloproteinases 1 and 2 exhibit broad-spectrum proteolytic capacities comparable to many matrix metalloproteinases," *Eur J Biochem.*, 250:751-757 (1997).

- Deutsch, DG, and ET Mertz, *Science* 170:1095-1096 (1970).
- Doolittle, RF, "Fibrinogen and fibrin," in Bloom AL, and Thomas DP, eds., *Hemostasis and Thrombosis* Churchill Livingstone, Edinburgh, New York (1987).
- Engvall, E, and E Ruoslahti, *Int J Cancer* 20:1-5 (1977).
- 5 Francic, CW, and VJ Marder, "Physiologic regulation and pathologic disorders of fibrinolysis," Chapter 54 in *Hemostasis and Thrombosis: Basic Principles and Clinical Practice*, 3rd ed., Colman, RW, J Hirsh, VJ Marder, and EW Salzman, eds., JB Lippincott Co, Philadelphia (1994).
- Fu, Y, and G Grieninger, "Fib<sub>420</sub>: A normal human variant of fibrinogen with two extended  $\alpha$  chains," *Proc Natl Acad Sci USA* 91:2625-28 (1994).
- 10 Gabriel, DA, K Muga, and EM Boothroyd, "The effect of fibrin structure on fibrinolysis," *J Biol Chem* 267:24259-63 (1992).
- Galis, ZS, GK Sukhova, MW Lark, and P Libby, "Increased expression of matrix metalloproteinases and matrix degrading activity in vulnerable regions of human atherosclerotic plaques," *J Clin Invest* 94:2493-2503 (1994).
- Galis, ZS, GK Sukhova, R Kranzhofer, and P Libby, *Proc Natl Acad Sci USA* 92:402-406 (1995).
- 15 Gårdlund, B, B Kowalska-Loth, NJ Gröndahl, and B Blombäck, *Thromb Res* 1:371 (1972).
- Glick, BR, and JJ Pasternak, *Molecular Biotechnology: Principles and Applications of Recombinant DNA*, Chapter 17, pp. 99-99; 403-20 (1994).
- Goding, JW, in *Monoclonal Antibodies: Principles and Practice*, Academic Press, New York, NY (1986).
- Gramse, M, C Bingenheimer, and W Schmidt, *J Clin Invest* 61:1027-1033 (1978).
- 20 Guan, AL, D Retzios, GN Henderson, and FS Markland, *Arch Biochem Biophys* 289:197-207 (1991).
- Henney, AM, PR Wakeley, MJ Davies, K Foster, R Hembry, G Murphy, and S Humphries, "Localization of stromelysin gene expression in atherosclerotic plaques by *in situ* hybridization," *Proc Natl Acad Sci USA* 88:8154-58 (1991).
- Kleiner Jr, DE, and WG Stetler-Stevenson, "Structural biochemistry and activation of matrix metalloproteinases,"
- 25 *Curr Opin Cell Biol* 5:891-97 (1993).
- Kudryk, B, A Rohoza, M Ahadi, J Chin, and ME Wiebe, *Mol Immunol* 21:89-94 (1984).
- Kudryk, BJ, ZD Grossman, JG McAfee, and SF Rosebrough, "Monoclonal antibodies as probes for fibrin(ogen) proteolysis," Chapter 19 in *Monoclonal Antibodies in Immunoscintigraphy*, Chatal, J-F, ed., CRC Press, Boca Raton (1989a).
- 30 Kudryk, B, M Gidlund, A Rohoza, M Ahadi, D Coiffe, and JI Weitz, *Blood* 74:1036-1044 (1989b).
- Kudryk, B, A Rohoza, M Ahadi, M Gidlund, R Procyk, and GR Matsueda, *Thromb Haemostas* 65:898 (Abstract 714) (1991).
- Laemmli, UK, *Nature* 227:680-685 (1970).
- Laemmli, UK, and M Favre, "Maturation of the head of bacteriophage T4. I. DNA packaging events," *J Mol Biol*
- 35 80:575-99 (1973).
- Lee, SW, ML Kahn, and DA Dichek, "Control of clot lysis by gene transfer," *Trends Cardiovasc Med* 3:61-66 (1993).
- Liu, CY, JH Sobel, JI Weitz, KL Kaplan, and HL Nossel, *Thromb Haemostas* 56:100-106 (1986).
- Loewy, AG, UV Santer, M Wieczorek, JK Blodgett, SW Jones, and JC Cheronis, "Purification and characterization of a novel zinc-proteinase from cultures of *Aeromonas hydrophila*," *J Biol Chem* 268:9071-78 (1993).
- 40 Martin, GV, JW Kennedy, and VJ Marder, "Thrombolytic therapy for coronary artery disease," Chapter 73 in *Hemostasis and Thrombosis: Basic Principles and Clinical Practice*, 3rd ed., Colman, RW, J Hirsh, VJ Marder, and EW Salzman, eds., JB Lippincott Co, Philadelphia (1994).
- Matrisian, LM, "The matrix-degrading metalloproteinases," *BioEssays* 14:455-63 (1992).
- Matsudaira, P, *J Biol Chem* 262:10035-10038 (1987).
- 45 Matsueda, GR, and MS Bernatowicz, pp 133-136 in *Fibrinogen 3 - Biochemistry, Biological Functions, Gene Regulation and Expression*, Mosesson, MW, D Amrani, KR Siebenlist, and P DiOrio, eds., Elsevier Science Publishers BV, Amsterdam (1988).
- McDonagh, J, H Messel, RP McDonagh Jr, G Murano, and B Blombäck, "Molecular weight analysis of fibrinogen and fibrin chains by an improved sodium dodecyl sulfate gel electrophoresis method," *Biochim Biophys Acta*
- 50 257:135-42 (1972).
- Murphy, G; S Atkinson, R Ward, J Gavrilovic, and JJ Reynolds, "The role of plasminogen activators in the regulation of connective tissue metalloproteinases," *Ann NY Acad Sci*, 667:1-12 (1992).
- Nagase, H, JJ Enghild, K Suzuki, and G Salvesen, "Stepwise activation mechanisms of the precursor of matrix metalloproteinase 3 (stromelysin) by proteases and (4-aminophenyl)mercuric acetate," *Biochemistry* 29:5783-89
- 55 (1990).
- Nagase, H, Y Ogota, K Suzuki, JJ Enghild, and G Salvesen, "Substrate specificities and activation mechanisms of matrix metalloproteinases," *Biochem Soc Trans* 19:715-18 (1991).
- Nagase, H, AJ Barrett, and JF Woessner Jr, "Nomenclature and glossary of the matrix metalloproteinases," *Matrix*

Supplement 1:421-24 (1992).

Nagase, H, "Matrix Metalloproteinases," Chapter 7, pp. 153-204 in *Zinc Metalloproteases in Health and Disease*, Hooper, NM, ed., Taylor & Francis, London (1996).

Okada, Y, H Nagase, and ED Harris Jr, "A metalloproteinase from human rheumatoid synovial fibroblasts that digests connective tissue matrix components," *J Biol Chem* 261:14245-55 (1986).

Okada, Y, T Morodomi, JJ Enghild, K Suzuki, I Nakanishi, G Salvesen, and H Nagase, *Eur J Biochem* 194:721-730 (1990).

Plow, EF, and TS Edgington, *J Clin Invest* 56:30-38 (1975).

Plow, EF, *Biochim Biophys Acta* 630:47-56 (1980).

Plow, EF, and Edgington, TS, *Semin Thromb Haemostas* 8:36-56 (1982).

Procyk, R, L Adamson, M Block, and B Blombäck, *Thromb Res* 40:833-852 (1985).

Procyk et al., *Blood* 77, 1469-1475 (1991).

Purves, L, M Purves, and W Brandt, "Cleavage of fibrin-derived D-dimer into monomers by endopeptidase from puff adder venom (*Bitis arietans*) acting at cross-linked sites of the  $\gamma$ -chain. Sequence of carboxy-terminal cyanogen bromide  $\gamma$ -chain fragments," *Biochemistry* 26:4640-46 (1987).

Retzios, AD, and FS Markland Jr, "Purification, characterization, and fibrinogen cleavage sites of three fibrinolytic enzymes from the venom of *Crotalus basiliscus basiliscus*," *Biochemistry* 31:4547-57 (1992).

Sambrook, J, EF Fritsch, and T Maniatis, *Molecular Cloning. A Laboratory Manual*, 2d ed., Cold Spring Harbor Laboratory, Cold Spring Harbor (1989).

San, K-Y, and GN Bennett, "Expression systems for DNA processes," pp. 306-310 in Meyers, RA, ed. *Molecular Biology and Biotechnology*, VCH Publishers, Inc., New York (1995).

Sanchez, EF, A Magalhes, FR Mandelbaum, and CR Diniz, "Purification and characterization of the hemorrhagic factor II from the venom of the Bushmaster snake (*Lachesis muta muta*)," *Biochim Biophys Acta* 1074:347-56 (1991).

Sato, Hiroshi, Okada, Yasunori, and Seiki, Motoharu, "Membrane-Type Matrix Metalloproteinases (MT-MMPS) in Cell Invasion," *Thrombosis and Haemostasis*, 78(1):497-500 (1997).

Senior, RM, GL Griffin, J Fliszar, SD Shapiro, GI Goldberg, and HG Welgus, *J Biol Chem* 266:7870-7875 (1991).

Siebenlist, KR, and MW Mosesson, *Biochemistry* 31:936-941 (1992).

Smith, EB, GA Keen, A Grant, and C Stirk, *Arteriosclerosis* 10:263-275 (1990).

Sobel, BE, D Collen, and EB Grossbard, eds., *Tissue Plasminogen Activator in Thrombolytic Therapy*, Marcel Dekker, Inc., New York (1987).

Sterrenberg, L, M Gravesen, F Haverkate, and W Nieuwenhuizen, *Thromb Res* 31:719-728 (1983).

Suzuki, K, H Nagase, A Ito, JJ Enghild, and G Salvesen, *Biol Chem Hoppe-Seyler* 371:305-310 (1990).

Towbin, H, T Staehelin, and J Gordon, *Proc Natl Acad Sci USA* 76:4350-4354 (1979).

Welgus, HG, EJ Campbell, JD Cury, AZ Eisen, RM Senior, SM Wilhelm, and GI Goldberg, *J Clin Invest* 86:1496-1502 (1990).

Valenzuela, R, JR Shainoff, PM DiBello, JM Anderson, GR Matsueda, and BJ Kudryk, *Am J Pathol* 141:861-880 (1992).

Werb, Z, CM Alexander, and RR Adler, *Matrix Supplement* 1:337-343 (1992).

Woessner, JF, *FASEB J* 5:2145-2154 (1991).

Zavalova, LL, EV Kuzina, NB Levina, and IP Baskova, "Monomerization of fragment DD by destabilase from the medicinal leech does not alter the N-terminal sequence of the  $\gamma$ -chain," *Thrombosis Res* 71:241-44 (1993).

## Claims

1. A method of degrading fibrin(ogen), comprising contacting fibrin(ogen) with an amount of a fibrinolytic matrix metalloproteinase (MMP) effective for cleaving the fibrin(ogen).

2. A method according to Claim 1, wherein the fibrinolytic matrix metalloproteinase is a human matrix metalloproteinase.

3. A method according to Claim 1, wherein the fibrinolytic matrix metalloproteinase is a membrane-type metalloproteinase.

4. A method according to Claim 1, wherein the fibrinolytic matrix metalloproteinase is MT1-MMP.

5. A method according to Claim 1, wherein the fibrinolytic matrix metalloproteinase is selected from the group consisting of membrane-type 1 metalloproteinase MT1-4 MMPs (or MMPs 14-17).

6. A method according to Claim 1, wherein the method further comprises contacting the fibrin(ogen) with an effective amount of at least one adjuvant compound having thrombolytic activity.
- 5 7. A method according to Claim 6, wherein the at least one adjuvant compound having thrombolytic activity is selected from the group consisting of plasminogen activators, hirudin, enzyme inhibitors, enzymes, anticoagulants, antibodies, and synthetic peptides specific for platelet gpIIb/IIIa receptor.
8. A method according to Claim 7, wherein the plasminogen activator is selected from the group consisting of urokinase plasminogen activator (u-PA), tissue-type plasminogen activator (t-PA), streptokinase, and staphylokinase.
- 10 9. A method according to Claim 1, wherein the method is performed *in vivo*.
10. A method according to Claim 1, wherein the fibrin(ogen) comprises substantially purified fibrin or fibrinogen.
- 15 11. A method according to Claim 1, wherein the fibrin(ogen) is present in the form of a thrombus or an atherosclerotic plaque.
12. A method of fibrinolytic therapy, comprising administering to a subject in need of fibrinolytic therapy a therapeutically effective amount of a fibrinolytic matrix metalloproteinase.
- 20 13. A method according to Claim 12, wherein the fibrinolytic matrix metalloproteinase is a human matrix metalloproteinase.
14. A method according to Claim 12, wherein the fibrinolytic matrix metalloproteinase is a membrane-type metalloproteinase.
- 25 15. A method according to Claim 12, wherein the fibrinolytic matrix metalloproteinase is MT1-MMP.
16. A method according to Claim 12, wherein the fibrinolytic matrix metalloproteinase is selected from the group consisting of membrane-type 1 metalloproteinase MT1-4 MMPs (or MMPs 14-17).
- 30 17. A method according to Claim 12, wherein the method further comprises administering to the subject a therapeutically effective amount of at least one adjuvant compound having thrombolytic activity.
- 35 18. A method according to Claim 17, wherein the at least one adjuvant compound having thrombolytic activity is selected from the group consisting of a plasminogen activators, hirudin, enzyme inhibitors, enzymes, anticoagulants, antibodies, and synthetic peptides specific for platelet GP IIb/IIIa receptor.
19. A method according to Claim 18, wherein the plasminogen activator is selected from the group consisting of urokinase plasminogen activator (u-PA), tissue-type plasminogen activator (t-PA), streptokinase, and staphylokinase.
- 40 20. A method according to Claim 12, wherein the method is performed following thrombolytic therapy to inhibit vascular reocclusion.
- 45 21. A method according to Claim 12, wherein the method is performed following surgical intervention to inhibit restenosis.
22. A method according to Claim 12, wherein the method is performed to inhibit initial formation, or promote regression, of atherosclerotic plaques.
- 50 23. A composition for thrombolytic therapy, comprising a fibrinolytic matrix metalloproteinase that cleaves fibrin(ogen), and a pharmaceutically acceptable carrier.
24. A composition according to Claim 23, wherein the fibrinolytic matrix metalloproteinase is a membrane-type metalloproteinase.
- 55 25. A composition according to Claim 23, wherein the fibrinolytic matrix metalloproteinase is MT1-MMP.

26. A composition according to Claim 23, wherein the composition further comprises at least one adjuvant compound having thrombolytic activity.
- 5 27. A composition according to Claim 26, wherein the at least one adjuvant compound having thrombolytic activity is selected from the group consisting of plasminogen activators, hirudin, enzyme inhibitors, enzymes, anticoagulants, antibodies, and synthetic peptides specific for platelet GPIIb/IIIa receptor.
- 10 28. A composition according to Claim 27, wherein the plasminogen activator is selected from the group consisting of urokinase plasminogen activator (u-PA), tissue-type plasminogen activator (t-PA), streptokinase, and staphylokinase.
29. A kit for performing thrombolytic therapy, comprising a composition comprising a fibrinolytic matrix metalloproteinase, and a container.
- 15 30. A kit according to Claim 29, wherein the fibrinolytic matrix metalloproteinase is MT1-MMP.
31. A kit according to Claim 29, wherein the kit further comprises at least one adjuvant compound having thrombolytic activity, selected from the group consisting of plasminogen activators, hirudin, enzyme inhibitors, enzymes, anticoagulants, antibodies, and synthetic peptides specific for platelet GPIIb/IIIa receptor.
- 20 32. A kit according to Claim 29, further comprising means for administering a therapeutically effective amount of the composition.
- 25 33. A kit according to Claim 32, wherein the administering means includes means for administering the composition parenterally.
34. A diagnostic method for characterizing fibrin(ogen), comprising contacting fibrin(ogen) with a fibrinolytic matrix metalloproteinase to provide characteristic cleavage products of the fibrin(ogen).
- 30 35. A method according to Claim 34, wherein the fibrinolytic matrix metalloproteinase is MT1-MMP.
36. A method according to Claim 34, wherein the method further comprises contacting the cleavage products with at least one antibody that specifically binds with a domain of fibrin(ogen), and measuring specific binding of the antibody with the separated cleavage products.
- 35 37. A method according to Claim 36, wherein the antibody is detectably labeled with a detectable marker moiety.
38. A method according to Claim 36, wherein the antibody is selected from the group consisting of monoclonal antibodies, synthetic antibodies, chimeric antibodies, Fab antigen binding regions, and F(ab')<sub>2</sub> antigen binding regions.
- 40 39. A method of inhibiting thrombus formation by a medical-related apparatus, comprising contacting a medical-related apparatus with a composition comprising a fibrinolytic matrix metalloproteinase to provide a thrombus-inhibiting surface on the medical-related apparatus.
- 45 40. A method according to Claim 39, wherein the medical-related apparatus is selected from the group consisting of blood collection tubes, culture flasks, test plates, pipets, reagent containers, tubing, membranes, needles, cannulae, catheters, grafts, stents, filters, coils, valves, and the like.
- 50 41. A medical-related apparatus having thrombus-inhibiting properties, comprising a medical-related device having provided thereto a thrombus-inhibiting amount of a composition comprising a fibrinolytic matrix metalloproteinase.
42. Apparatus according to Claim 41, wherein the medical-related apparatus is selected from the group consisting of blood collection tubes, culture flasks, test plates, pipets, reagent containers, tubing, membranes, needles, cannulae, catheters, grafts, stents, filters, coils, and valves.
- 55 43. A method of enhancing regulation of fibrinolysis in a subject in need of such therapy, comprising inducing enhanced regulation of an endogenous fibrinolytic matrix metalloproteinase in a subject.

44. A method according to Claim 43, wherein the inducing step comprises increasing the activity or expression of an endogenous fibrinolytic matrix metalloproteinase by treating the subject with somatic cell gene transfer therapy.

5 45. A method according to Claim 43, wherein the inducing step comprises decreasing the activity or expression of an endogenous fibrinolytic matrix metalloproteinase by treating the subject with somatic cell gene transfer therapy.

10

15

20

25

30

35

40

45

50

55

FIG-1

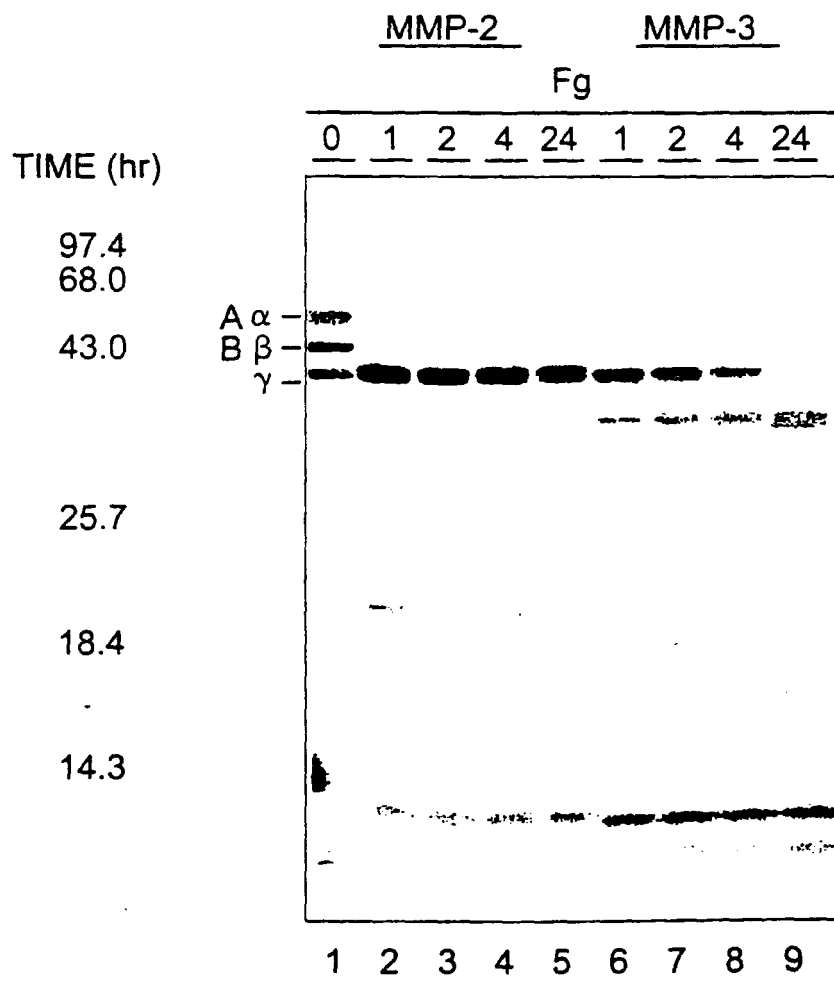
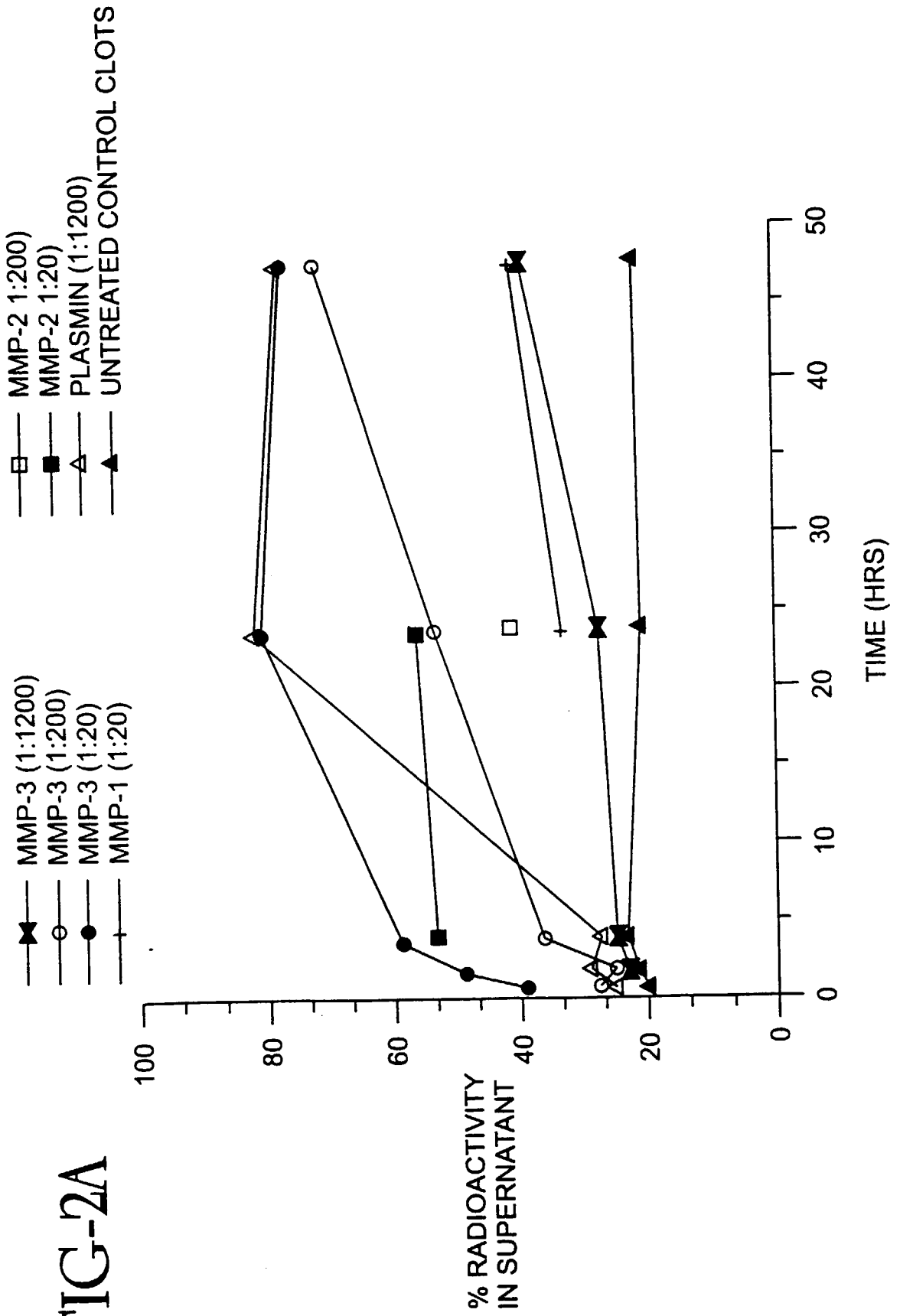
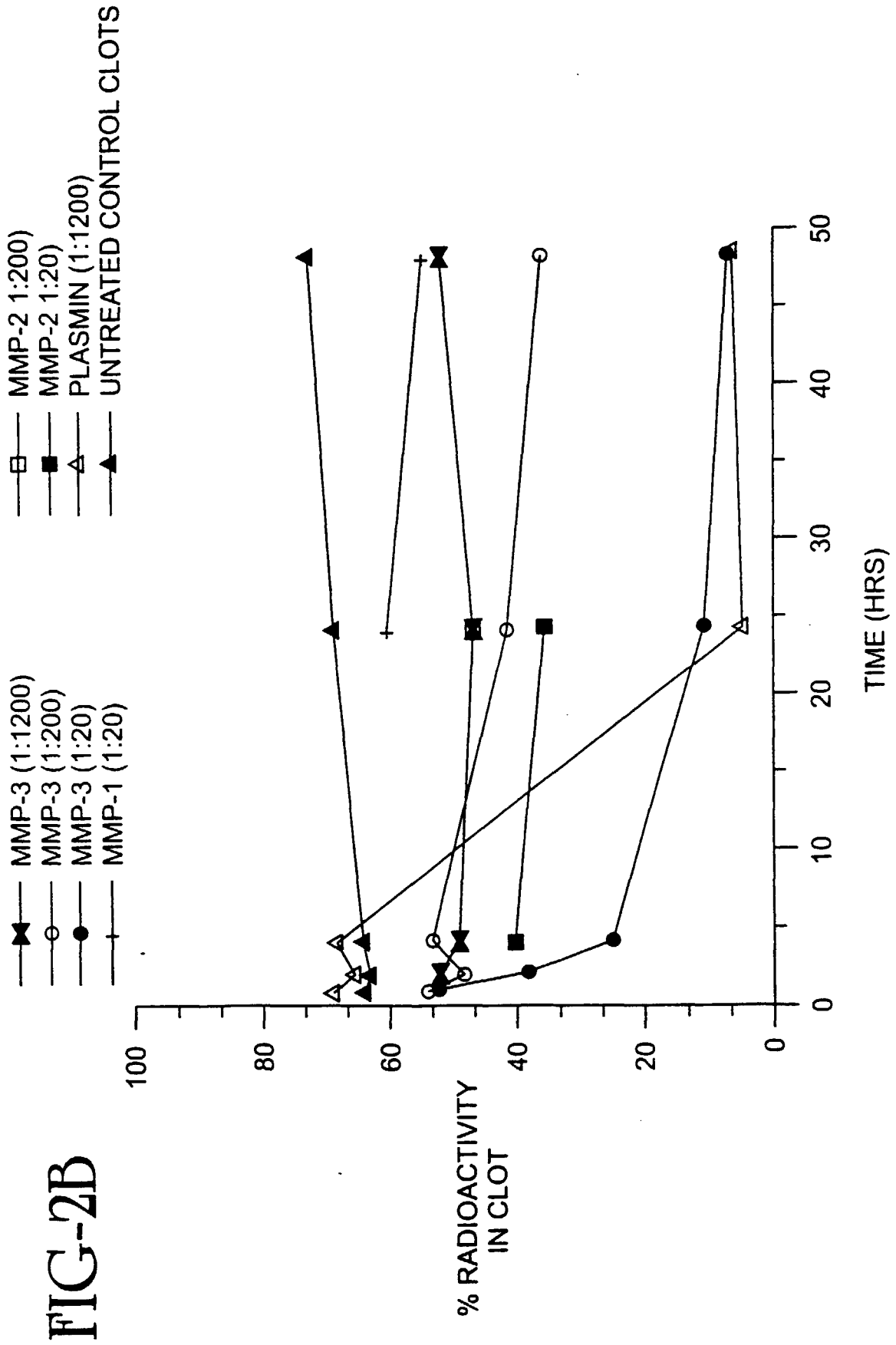

FIG-2A







# FIG-4A

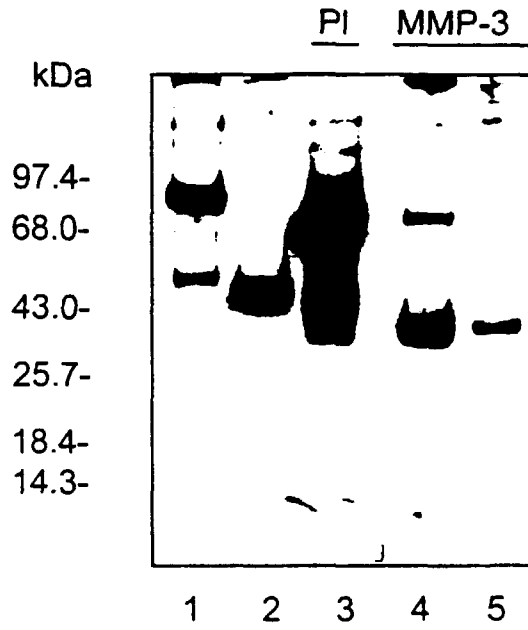

# FIG-4B

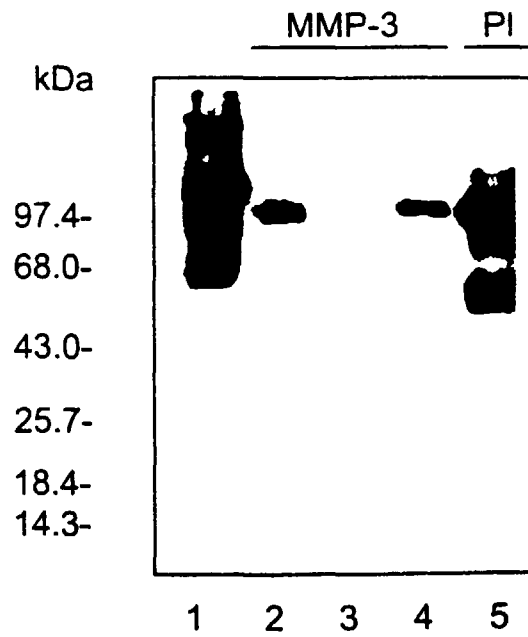
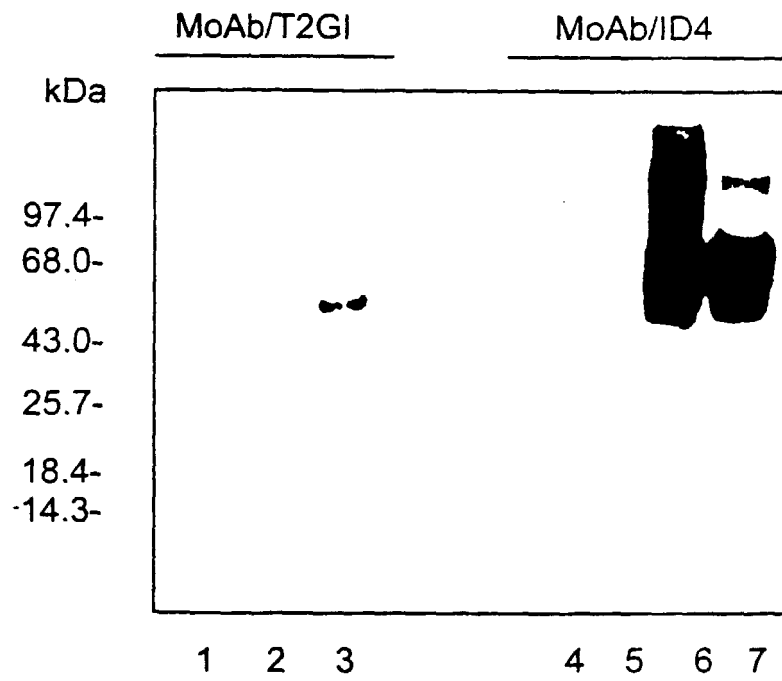
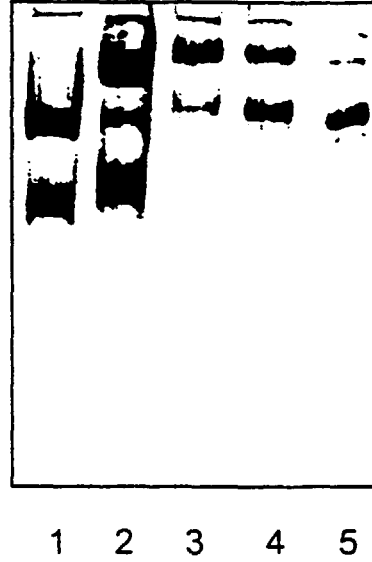

FIG-5



# FIG-6A

D-dimer (186 kDa)-  
D (93 kDa)-



# FIG-6B

$\gamma$ -dimer (76 kDa)-  
 $\beta$  (43 kDa)-  
 $\gamma$  (38 kDa)-  
 $\alpha$  (12 kDa)-

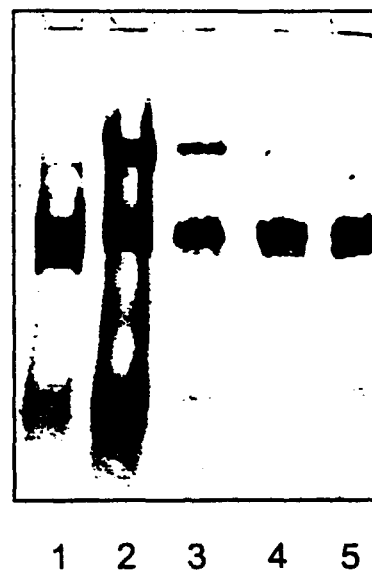
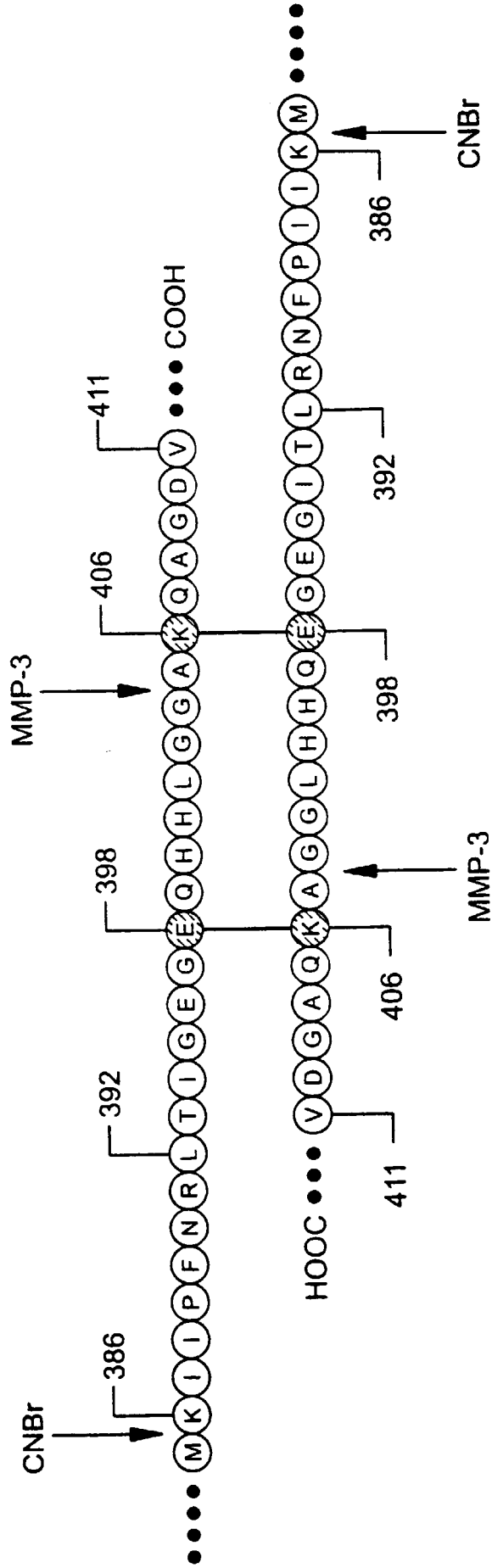

FIG-7



# FIG-8

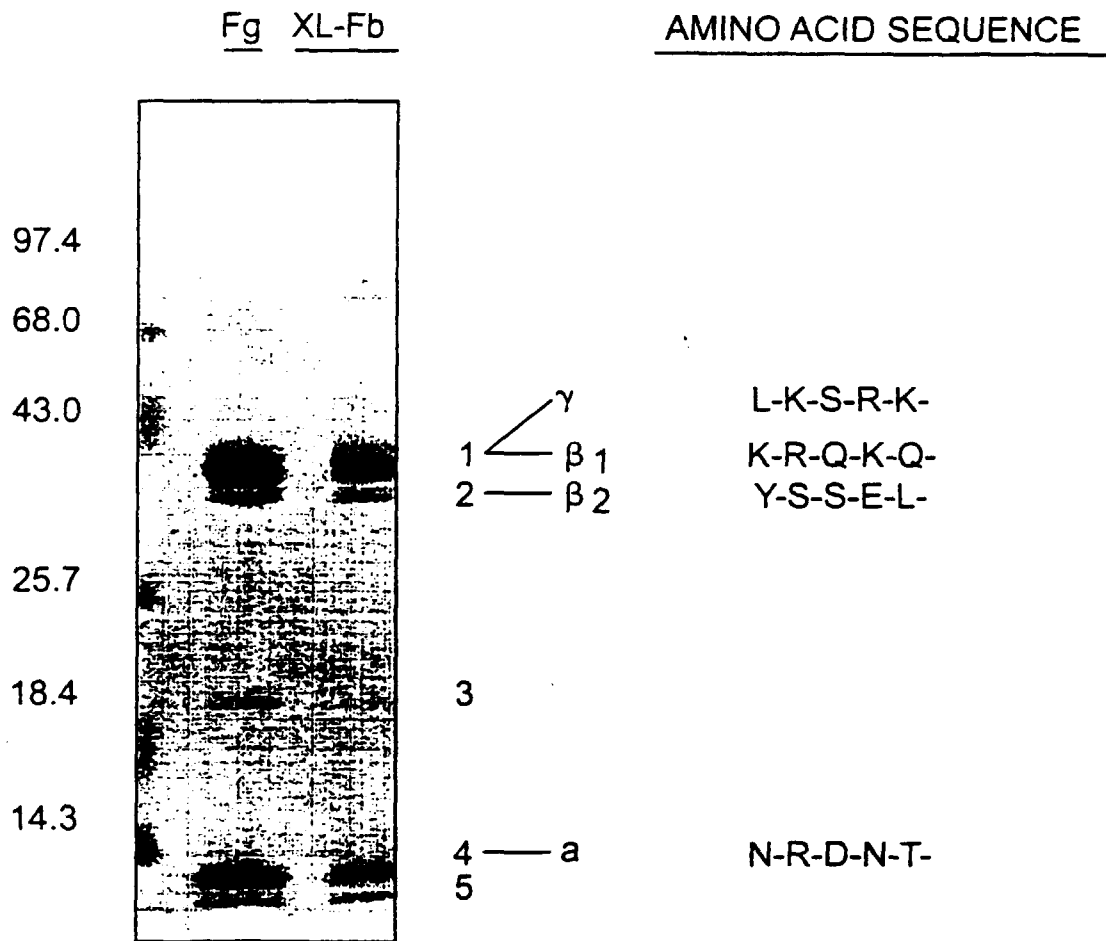

FIG-9

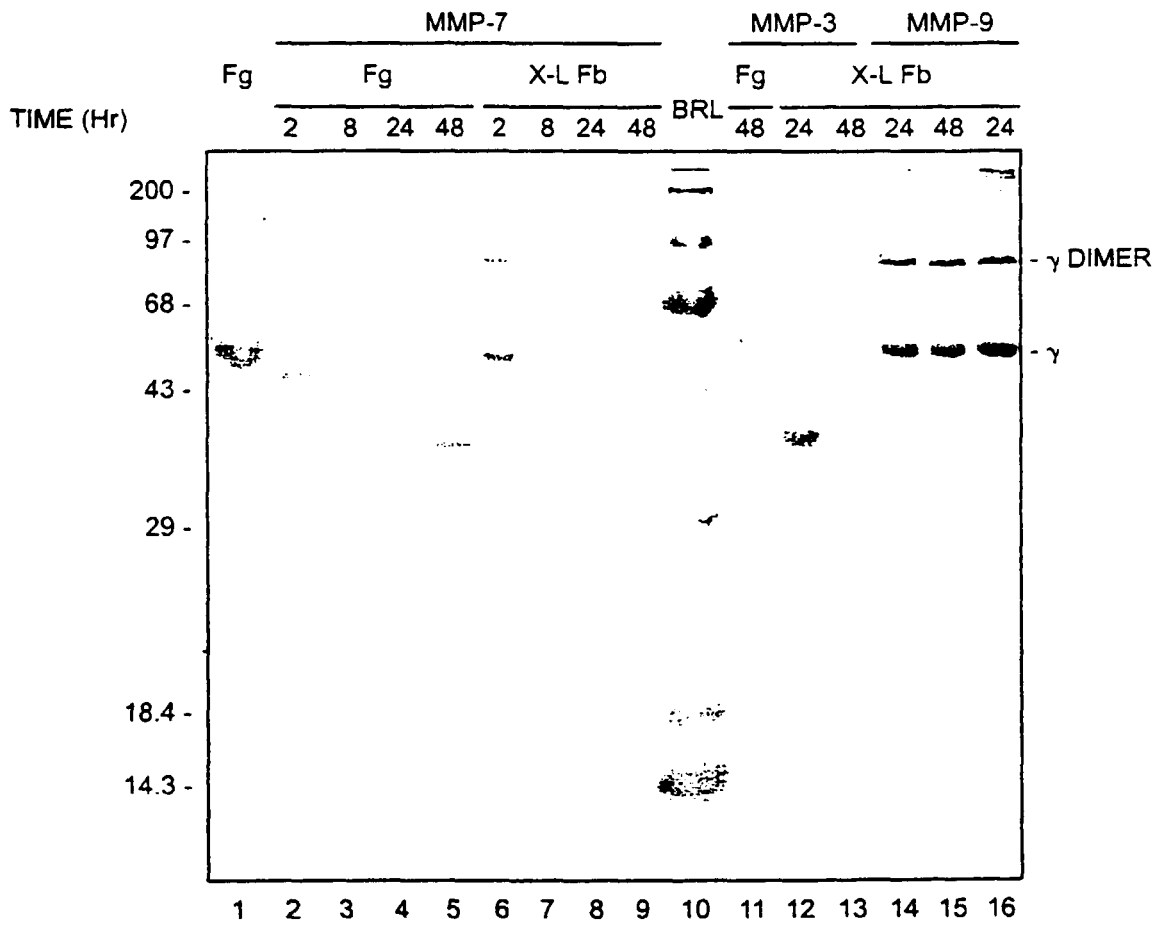
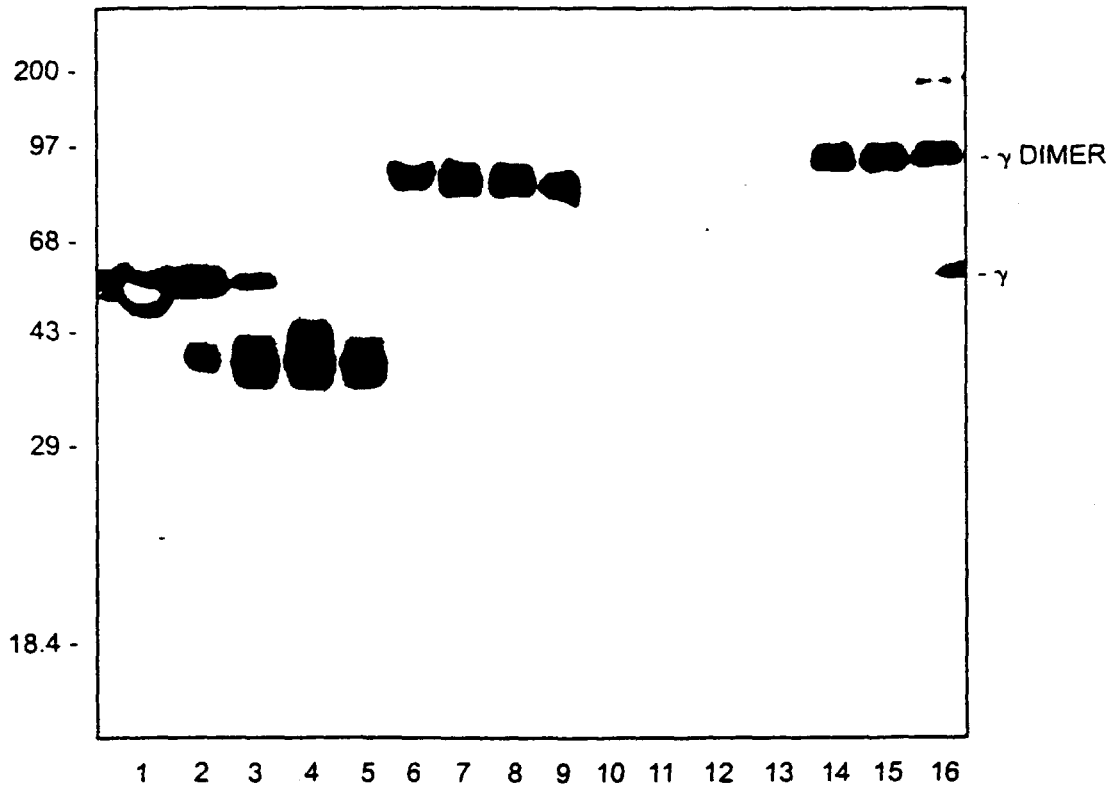

FIG-10



专利名称(译)	纤维蛋白 (ogen) 降解和纤维蛋白溶解金属蛋白酶凝块溶解		
公开(公告)号	<a href="#">EP1060747A2</a>	公开(公告)日	2000-12-20
申请号	EP2000202122	申请日	2000-06-16
[标]申请(专利权)人(译)	紐約血液中心有限公司		
申请(专利权)人(译)	纽约血液中心, INC.		
当前申请(专利权)人(译)	纽约血液中心, INC.		
[标]发明人	BINI ALESSANDRA		
发明人	BINI, ALESSANDRA		
IPC分类号	A61K38/48 A61K38/49 A61K48/00 A61L33/00 A61P7/02 C12Q1/56 G01N33/53		
CPC分类号	A61K38/4886 A61K38/49 A61K48/00 A61L33/0047 A61P7/02 C12Q1/56 G01N2333/75 G01N2333/96486 A61K2300/00		
优先权	09/334090 1999-06-16 US		
其他公开文献	EP1060747A3		
外部链接	<a href="#">Espacenet</a>		

摘要(译)

本发明提供了一种通过纤维蛋白溶解基质金属蛋白酶, 优选MT1-MMP引起纤维蛋白 (ogen) (即纤维蛋白, 纤维蛋白原和相关物质) 降解的方法。本发明的方法可以在体外进行, 以提供表征纤维蛋白 (ogen) 和纤维蛋白溶解生理学的诊断信息。该方法还可以作为溶栓治疗方法在体内进行, 其中将纤维蛋白溶解基质金属蛋白酶给予受试者以原位降解血栓。纤维蛋白溶解基质金属蛋白酶可以与其他活性剂联合给药, 优选与具有血栓溶解活性的药剂一起给药, 以改善血栓溶解和纤维蛋白溶解疗法。本发明进一步提供含有纤维蛋白溶解基质金属蛋白酶的组合物, 用于进行纤维蛋白溶解或血栓溶解程序。还提供了包含纤维蛋白溶解基质金属蛋白酶的试剂盒, 用于进行纤维蛋白溶解或血栓溶解程序。

TABLE I  
Thrombin Clotting Times

Sample	ES w/w	Concentration µg	Incubation time (hrs)	Thrombin time	Turbidity (same day)	Turbidity (next day)
ES control (untreated) (120 µg)	-	-	-	8.3"	0.841	0.573 (n=5)
MMP-2	1:800	0.2	1.5	> 15 min	-	0.222
			3	uncloable	-	0.222
			3	soft clot	-	0.102
			3	next day	-	-
	1:200	0.5	1.5	> 10 min	0.433	0.323
			3	12' 01"	0.377	0.322
			3	> 1 min	0.331	1.038
			3	> 1 min	0.753	1.125
MMP-3	1:800	0.2	1.5	> 10 min	-	0.225
			3	uncloable	-	0.035
			3	soft clot	-	0.004
			3	the next day	-	0.029
	1:200	0.5	1.5	> 10 min	-	0.001
			3	uncloable	-	0
			3	no clot	-	0.008
			3	the next day	-	0.012
Plasmin	1:1200	0.1	1.5	107.5"	0.356	all
			3	103.9"	0.355	clots
			3	60.3" 7'	0.445	digested
			3	139.1"	0.502	C.N.
	1:240	0.5	1.5	uncloable	-	-
			3	-	-	-
			3	-	-	-
			3	-	-	-