



(51) International Patent Classification:

<i>G01N 27/327</i> (2006.01)	<i>G01N 27/30</i> (2006.01)
<i>C12M 1/00</i> (2006.01)	<i>G01N 21/66</i> (2006.01)
<i>G01N 33/533</i> (2006.01)	<i>G01N 27/416</i> (2006.01)
<i>C12Q 1/00</i> (2006.01)	<i>G01N 33/536</i> (2006.01)
<i>G01N 21/76</i> (2006.01)	<i>G01N 21/00</i> (2006.01)
<i>G01N 33/566</i> (2006.01)	<i>C12M 1/34</i> (2006.01)
<i>G01N 33/58</i> (2006.01)	<i>G01N 33/53</i> (2006.01)
<i>G01N 33/543</i> (2006.01)	

13/844,527 15 March 2013 (15.03.2013) US
PCT/US201 3/041252 15 May 2013 (15.05.2013) US

(71) Applicant: **WELLSTAT DIAGNOSTICS, LLC** [US/US]; 930 Clopper Road, Gaithersburg, MD 20878 (US).

(72) Inventors: **COOK, Richard Alan**; 6912 Tennyson Terrace, Derwood, MD 20855 (US). **CHO, Sang**; 811 Royal Crescent, Rockville, MD 20850 (US). **DAVIS, Charles Quentin**; 3621 Byron Circle, Frederick, MD 21704 (US). **DORSEY, Kevin E.**; PO Box 1211, Germantown, MD 20875-1211 (US). **HARLEY, Jason Charles**; 8237 Cambourne Court, Gaithersburg, MD 20877 (US). **LELAND, Jonathan**; 19508 Pine Cone Court, Gaithersburg, MD 20879 (US). **MATIKYAN, Rober Krikor**; 9220 Falls Chapel Way, Potomac, MD 20854 (US). **OTTEN, Sjeff**; 20011 Mattingly Terrace, Gaithersburg, MD 20879 (US). **PETERMAN, Jeffrey Howard**; 1505 Castle Cliff Place, Silver Spring, MD 20904 (US). **THOMAS, Brian B.**; 2617 Island Cove Boulevard, Frederick, MD 21701 (US).

(21) International Application Number:

PCT/US2013/041255

(22) International Filing Date:

15 May 2013 (15.05.2013)

(25) Filing Language:

English

(26) Publication Language:

English

(30) Priority Data:

61/647,272	15 May 2012 (15.05.2012)	US
PCT/US20 12/067041		
	29 November 2012 (29.11.2012)	US
13/844,450	15 March 2013 (15.03.2013)	US

(74) Agent: **CIESLIGA Camille**; Legal Department, 930 Clopper Road, Gaithersburg, MD 20878 (US).

[Continued on nextpage]

(54) Title: CLINICAL DIAGNOSTIC SYSTEMS

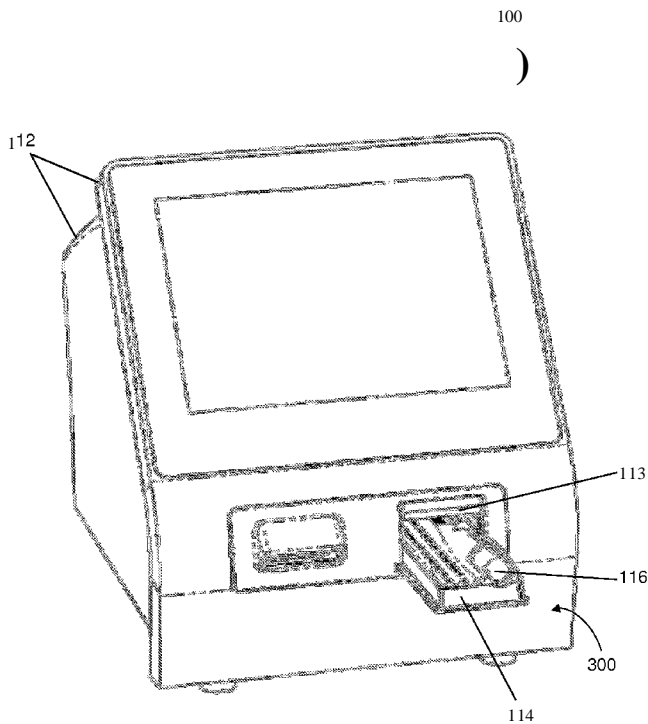

FIG. 3

(57) Abstract: A diagnostic system is provided herein that includes an instrument comprising an electrochemiluminescence (ECL) detector, and a cartridge configured to fit within a portion of the instrument, wherein the cartridge includes at least one reagent including an ECL label and a blood collection holder. Also provided herein is a system that includes a diagnostic instrument, which includes a pump, an ECL detector, an incubator, a magnet, and an output device, and a cartridge configured to fit within a portion of the diagnostic instrument, a sample holder configured to fit within the cartridge, and a closed fluidic loop between the diagnostic instrument and the cartridge when the cartridge is fit within a portion of the diagnostic instrument, wherein the cartridge is configured to accept a sample from the sample holder and place the sample in fluidic communication with the diagnostic instrument via the closed fluidic loop.

WO 2013/173525 A1

(81) **Designated States** (unless otherwise indicated, for every kind of national protection available): AE, AG, AL, AM, AO, AT, AU, AZ, BA, BB, BG, BH, BN, BR, BW, BY, BZ, CA, CH, CL, CN, CO, CR, CU, CZ, DE, DK, DM, DO, DZ, EC, EE, EG, ES, FI, GB, GD, GE, GH, GM, GT, HN, HR, HU, ID, IL, IN, IS, JP, KE, KG, KM, KN, KP, KR, KZ, LA, LC, LK, LR, LS, LT, LU, LY, MA, MD, ME, MG, MK, MN, MW, MX, MY, MZ, NA, NG, NI, NO, NZ, OM, PA, PE, PG, PH, PL, PT, QA, RO, RS, RU, RW, SC, SD, SE, SG, SK, SL, SM, ST, SV, SY, TH, TJ, TM, TN, TR, TT, TZ, UA, UG, US, UZ, VC, VN, ZA, ZM, ZW.

(84) **Designated States** (unless otherwise indicated, for every kind of regional protection available): ARIPO (BW, GH,

GM, KE, LR, LS, MW, MZ, NA, RW, SD, SL, SZ, TZ, UG, ZM, ZW), Eurasian (AM, AZ, BY, KG, KZ, RU, TJ, TM), European (AL, AT, BE, BG, CH, CY, CZ, DE, DK, EE, ES, FI, FR, GB, GR, HR, HU, IE, IS, IT, LT, LU, LV, MC, MK, MT, NL, NO, PL, PT, RO, RS, SE, SI, SK, SM, TR), OAPI (BF, BJ, CF, CG, CI, CM, GA, GN, GQ, GW, ML, MR, NE, SN, TD, TG).

Published:

- with international search report (Art. 21(3))
- before the expiration of the time limit for amending the claims and to be republished in the event of receipt of amendments (Rule 48.2(h))

CLINICAL DIAGNOSTIC SYSTEMS

CROSS-REFERENCE TO RELATED APPLICATIONS

[0001] This application claims priority to U.S. Provisional Application No. 61/647,272, filed May 15, 2012; International PCT Application No. PCT/US2012/067041, filed on November 29, 2012; U.S. Patent Application No. 13/844,450, filed on March 15, 2013; U.S. Patent Application No. 13/844,527, filed March 15, 2013; and International PCT Application filed on May 15, 2013, entitled "CLINICAL DIAGNOSTIC SYSTEM INCLUDING INSTRUMENT AND CARTRIDGE," the application having attorney docket number 20108.1-PCT, with inventors R. Cook, S. Cho, C. Davis, K. Dorsey, J. Harley, J. Leland, R. Matikyan, S. Otten, J. Peterman, B. Thomas, and assigned application serial number PCT/US2013/041252, each of which is herein incorporated by reference in its entirety.

BACKGROUND

[0002] In the healthcare industry, diagnostic testing is essential for properly diagnosing medical issues. Accuracy and precision are necessary to provide proper diagnoses. In order to provide accuracy and precision, diagnostic systems have been created to analyze samples in laboratories, clinics, hospitals, physicians' offices, etc.

[0003] Providing clinical point-of-care diagnostic systems, as well as other diagnostic systems also requires ease of use and fail safe mechanisms in order to decrease the frequency and intensity of user errors, which may lead to inaccurate diagnoses.

[0004] Furthermore, the size and scale of the diagnostic systems is also important. In order to be able to use diagnostic systems in certain settings, compactness may also be needed. To this end, the system may include both an instrument and separate cartridges used to provide samples to the instrument in the diagnostic systems. The cartridges may also need to be designed to assist in the compactness of the instrument.

[0005] Additionally, design of the cartridges used to provide samples to the diagnostic systems may also be designed to require less biological sample for testing, as well as be designed with ease of use and with fail safe mechanisms to further assist in the accuracy of diagnoses.

SUMMARY

[0006] Diagnostic systems, which include an instrument and associated cartridges, are provided herein. The diagnostic systems can provide accuracy and precision, ease of use with fail safe mechanisms, and compactness of scale.

[0007] As disclosed herein, embodiments of diagnostic systems may include clinical diagnostic instruments that can be configured to accept samples via cartridges, process samples within the cartridges, conduct tests on the samples while the samples remain within the cartridges, and provide diagnostic results.

[0008] Also disclosed herein, embodiments of the diagnostic system may be self-contained diagnostic systems in that a closed fluidic loop between an instrument and a cartridge containing a sample may be used. By providing self-contained diagnostic systems, the instrument can be maintained by disposing of the contents of the cartridge back into the cartridge, which can leave the instrument ready for another cartridge and test.

[0009] Furthermore, as disclosed herein, embodiments of diagnostic systems may include electrochemiluminescence (ECL) detectors to accurately and precisely analyze samples provided via cartridges. ECL detectors may include detectors similar to ones used in U.S. Patent Nos. 5,700,427, 5,296,191, and 5,624,637, which are each incorporated herein by reference.

[0010] In embodiments disclosed herein, an in vitro diagnostic system is provided that is designed for use in Point of Care (POC) settings. Example embodiments can provide rapid, real-time test results for a variety of clinically important analytes. Example embodiments can also perform immunoassays using ECL-based detection technology. In example embodiments, assays may be available in single-use, disposable cartridges, which may contain all the reagents required to

perform a test. In example embodiments, there may be no sample processing before a test is performed can be provided. For example, blood collection holders, such as a standard blood tube may be inserted directly into an example cartridge without any processing, such as centrifuging, and the cartridge along with a blood collection holder may be placed into the instrument for processing. Results can be available within 15 minutes, depending on the number of tests being run with in the cartridge.

[001 1] In embodiments disclosed herein, example diagnostic systems can provide central laboratory quality results in an easy to use, low cost system.

[001 2] In example embodiments, a diagnostic system having an instrument including an ECL detector; and a cartridge configured to fit within a portion of the instrument is provided. In example embodiments, the cartridge can include at least one reagent including an ECL label; and a blood collection holder.

[001 3] In example embodiments, a system having a diagnostic instrument including a pump; an ECL detector; an incubator; a magnet; and an output device is provided. Additionally, the system may also have a cartridge configured to fit within a portion of the diagnostic instrument; a sample holder configured to fit within the cartridge; and a closed fluidic loop between the diagnostic instrument and the cartridge when the cartridge is fit within a portion of the diagnostic instrument, wherein the cartridge is configured to accept a sample from the sample holder and place the sample in fluidic communication with the diagnostic instrument via the closed fluidic loop.

[0014] In example embodiments, a method of providing POC services, which can include the steps of providing a biological sample; introducing the biological sample to a cartridge; providing the cartridge to a diagnostic instrument comprising an ECL detector; mixing the biological sample with a reagent in the cartridge to form a biological sample-reagent mixture; analyzing the biological sample-reagent mixture using the ECL detector; and outputting the results from the analyzing step is provided.

BRIEF DESCRIPTION OF THE DRAWINGS

[001 5] The accompanying drawings, which are incorporated and constitute a part of this specification, illustrate an embodiment of the invention. In the drawings,

[001 6] FIG. 1 is an overview illustration of an example diagnostic system;

[001 7] FIG. 2 is an overview illustration of an example method by which an example diagnostic system may be used;

[001 8] FIG. 3 is an illustration of an embodiment of a diagnostic system;

[001 9] FIG. 4 is an overview illustration of an example method by which a biological sample is processed in a diagnostic system;

[0020] FIG. 5 is an illustration of an example filtration module

[0021] FIG. 6 is an illustration of an example of a testing sample that has been divided into volumes within the cartridge;

[0022] FIG. 7 is an illustration of components used in mixing the testing sample with reagents within a cartridge;

[0023] FIG. 8 is an illustration of an example cartridge positioned on an example incubator within an example instrument;

[0024] FIG. 9 is an illustration of an example cartridge provided with a magnet for use in an example washing step;

[0025] FIG. 10A is an illustration of a portion of an example instrument that can be used to analyze a sample;

[0026] FIG. 10B is an illustration of a cross section of an example ECL detection apparatus in a diagnostic system;

[0027] FIG. 11 is an illustration of a portion of an example cartridge that can be used to hold discarded products of a sample test;

[0028] FIG. 12 is an illustration of example outputs that may be provided by an example diagnostic system;

[0029] FIG. 13 is an illustration of a fluidic pathway between an example instrument and an example cartridge of an example diagnostic system;

[0030] FIG. 14A is an illustration of an exploded perspective view of an example body and a cover of a cartridge of a diagnostic system;

[0031] FIG. 14B is an illustration of an exploded perspective view of an example cartridge of a diagnostic system;

[0032] FIG. 15A is an illustration of a perspective view of an example of the front and back of a cartridge cover of a diagnostic system;

[0033] FIG. 15B is an illustration of a perspective view of an example of a portion of a cartridge cover of a diagnostic system;

[0034] FIG. 16 is a flow chart for an example instrument-driven work flow;

[0035] FIG. 17 is an overview illustration of an example closed fluidic path between a diagnostic instrument and a cartridge; and

[0036] FIG. 18 is an illustration of an example of an internal standard (IS), non-ECL detection apparatus.

DETAILED DESCRIPTION

[0037] The following detailed description refers to the accompanying drawings. The same reference numbers in different drawings may identify the same or similar elements. Also, the following detailed description describes embodiments of the invention and is not intended to limit the invention. Instead, the scope of the invention is defined by the appended claims and equivalents.

[0038] A. Overview

[0039] Provided herein is a clinical diagnostic system that includes a cartridge and an instrument. The clinical diagnostic system can provide accuracy and

precision of test results, ease of system use, including fail safe mechanisms, and compactness in terms of scale. By providing a robust system that utilizes ECL technology with an efficient and accurate instrument and cartridge, users of the system can be assured accurate results with very little training or set up.

[0040] In embodiments disclosed herein, a clinical diagnostic system can provide rapid, real-time test results for a variety of clinically important analytes. Example clinical diagnostic system embodiments can perform immunoassays using ECL-based detection technology with assays available in disposable cartridges, which may contain all the reagents required to perform a test.

[0041] **B. Definitions**

[0042] The following are definitions of terms related to a diagnostic system in general.

[0043] The term "assay construction" as used herein is intended to include a step-by-step process of conducting an assay whether manual or automated. Assay construction may involve laboratory operations, such as pipetting, dispensing, metering, aliquoting, washing, free-bound separations, dialyzing, filtering, collecting, fractionating, diluting, mixing, incubating, processing, and the like.

[0044] The term "assay composition" as used herein is intended to include a complete set or subset of the necessary reagents or substances useful for an assay when combined. An assay composition may include an initial composition prior to assay construction, a composition immediately after initiating assay construction, a final mixture after assay construction, or a composition at any intermediate step of assay construction.

[0045] The term "bead(s)" as used herein is intended to include microscopic particles, such as superparamagnetic particles, magnetic microparticles, magnetic nanoparticles, or other particles of microscopic size. A bead may be spherical, though the shape is not limited and may include other shapes like spheroid, irregular particles, cubes, irregular cubes, and disks. The size range may cover from 1 nanometer to 10 microns in width.

[0046] The term "closed loop control" as used herein is intended to include a control module with one or more sensors to modulate a diagnostic system response. The term "open loop control" is contrasted with "closed loop control" and "open loop control" includes modules that do not provide a feedback signal to modulate a system response.

[0047] The term "dead volume" as used herein is intended to include a volume of a liquid trapped within a designated compartment, such as a sample holder or a reservoir, which may be unrecoverable.

[0048] The term "disposable" as used herein is intended to include items, such as single-use cartridges, which can be disposable after initial use and can contain an amount of reagents sufficient for testing a single biological sample before disposal of the cartridge.

[0049] The term "fluidic element" as used herein is intended to include a structure to hold, carry, or allow transport of a fluid. Fluidic elements may include pipes, channels, wells, reservoirs, conduits, valves, vents, flow paths, dispersers, pipettes, funnels, filters, and/or passageways.

[0050] The term "fluidic communication" as used herein is intended to include fluidic elements that may be in fluidic communication with other fluidic elements if the fluidic elements are connected via a channel, passageway, pathway, conduit, flow path or other fluidic element. Further, fluidic elements may also be in fluidic communication if they are connectable or transferable by a pipette or other transferable means, for example. Further, adjacent or nearby fluidic elements which liquid may be dispensed or transferred by pipette between or from one to the other may be in fluidic communication.

[0051] The term "fluorescence" as used herein is intended to include any emission of electromagnetic radiation, including ultraviolet or visible light, stimulated in a substance by the absorption of incident radiation and persisting only as long as the stimulating radiation is continued.

[0052] The term "fluorophore" as used herein refers to a substance that is fluorescent.

[0053] The term "fluorescent label" as used herein is intended to include a fluorophore used in the detection or measurement of fluorescence. A substance which is fluorescent yet detected by another detection method, such as ECL, is not a fluorescent label. A fluorescent label is operative when measuring fluorescence. Fluorescent beads are intended to include fluorescent labeled beads.

[0054] The term "Point of Care" as used herein is intended to include places or people that include laboratories, clinics, hospitals, physicians offices, etc., as well as, health care providers, clinicians, or others who may deliver healthcare products and services.

[0055] The term "precise" as used herein is intended to include situations when reproducibility and repeatability of a characteristic may occur. The term "highly precise" as used herein is intended to include situations when a characteristic variation is small over many observations of the characteristic.

[0056] The term "processed" as used herein is intended to include materials that may have been altered from their original or unused state (in relation to a diagnostic system), such as, for example, combined or mixed with other materials, reagents, samples or a combination thereof.

[0057] The term "standardized quantity" as used herein is intended to include a known amount of a substance, where the amount might be mass, concentration, volume, number, or other physical quantity. The known amount may have been determined or may be traceable to a reference method, golden standard, National Institute of Standards and Technology (NIST) traceable standard, or other method or standard. A known amount of a substance may also be determined by comparing an analytical result to a calibrator.

[0058] **C. Diagnostic System**

[0059] FIG. 1 is an overview illustration of an example diagnostic system 100. As illustrated in FIG. 1, diagnostic system 100 may include an instrument 112, a cartridge 114, and a sample holder 116 within the cartridge 114. Example instruments 112 can be configured to accept example cartridges 114. Example instruments 112 can include ECL detection technology to detect analytes in samples. Example cartridges 114 can be configured to accept sample holders. Further discussion of instruments 112 and cartridges 114 will follow below.

[0060] FIG. 2 is an overview illustration of an example method 200 by which an example diagnostic system 100 may be used. As illustrated in FIG. 2, method 200 may include the step of collecting a biological sample 210. Example procedures for collecting a biological sample 210 may include any method available for gathering biological samples, such as venipuncture, finger stick, heel stick, arterial blood draw cannulation, etc. The biological samples may be gathered into a vial, tube, blood collection tube, and VACUTAINER® for example.

[0061] The step of collecting a biological sample 210 can also include verifying sample-patient identification. Verification can be confirmed by comparing sample identification with patient identification. For example, identification can be performed by comparing a label placed on a sample holder with a patient identification card or wrist band.

[0062] Method 200 may include the step of selecting a diagnostic test 220. Example procedures for selecting a diagnostic test 220 may include identifying information provided on a sample regarding a desired test or other processes of accessing selection of diagnostic tests information. For example, a sample vial may have a code or instructions indicating which tests should be run on the sample, and the selection of a diagnostic test can be directly identified and selected automatically or manually by an operator of instrument 112.

[0063] Method 200 may include the step of introducing a sample into a cartridge 300. Example procedures for introducing a sample into a cartridge 300

may include any method available for introducing a sample into a cartridge, such as inserting a blood collection tube into a preconfigured area of a cartridge. In embodiments discussed further below, the introducing a sample into a cartridge 300 may be provided as illustrated in FIG. 1, wherein sample holder 116 is configured to fit within a preconfigured section of cartridge 114. The preconfigured section, as an example, includes means for mounting sample holder such as a sample holder needle.

[0064] Method 200 may include the step of introducing a cartridge into an instrument 350. Example procedures for introducing a cartridge into an instrument 350 may include any method available for introducing a cartridge into an instrument, such as inserting a cartridge into a preconfigured area of an instrument. In embodiments discussed further below, the introducing a cartridge into an instrument 350 may be provided as illustrated in FIG. 1, wherein cartridge 114 is configured to fit within a preconfigured section of instrument 112. For example, as illustrated in FIG. 3, cartridge 114 may be inserted into slot 113 in instrument 112 of system 100.

[0065] Method 200 may include the step of processing a sample 400. Example procedures for processing a sample 400 may include any a series of sub-steps designed to construct an assay, analyze the sample, and provide information about the sample. In embodiments discussed further below, the processing a sample 400 may be provided as illustrated in FIG. 4.

[0066] In FIG. 4, an embodiment of the step of processing a sample 400 can include several sub-steps 404 to 414, wherein each step is optional and can include additional sub-steps that may not be discussed herein.

[0067] The step of processing a sample 400 can include the sub-step of filtering a biological sample to yield a testing sample 404. Example procedures for filtering a biological sample 404 may include separating one part of a sample from another part. For example, filtering a whole blood biological sample may include separating plasma from whole blood.

[0068] As illustrated in FIG. 5, a filtration module 510 can be provided to filter a biological sample. As illustrated in FIG. 5, a biological sample flow path 520 may be flowed through a filtration module 510. In example embodiments, the filtration module 510 can include one or more filters 530, where the biological sample flow path 520 is divided by the one or more filters 530 into a testing sample 540 and a waste product 550. The testing sample 540 can be collected into a testing sample cache 545. The waste product can be collected into a waste product collector 555. It is contemplated that the filtration module 510 can be configured to have one or more filtration layers within each filter 530, where the number and types of filtration layers 530 can depend on one or more targeted filtration factors, as well as structural integrity factors. For example, the number and types of filtration layers can depend on the targeted filtrate, the design and configuration of the cartridge, and/or the diagnostic system. Additionally, the filtration layers may include several layers of the same filtration material or different filtration materials.

[0069] Some embodiments of the diagnostic system 110 contemplate that a filtration module 510 can be situated within the cartridge 114. It is further contemplated that the filtration module 510 can be adapted to fit within cartridge 114. By providing the filtration module 510 within cartridge 114, a testing sample 540 (e.g., plasma) can be gathered without the need for centrifugation of the sample 400, for example. Further discussion of the filtration module 510 can be found in PCT/US2012/067041, which is hereby incorporated in its entirety by reference.

[0070] The step of processing a sample 400 can include the sub-step of dividing the testing sample 540 into aliquots 406. Once the testing sample 540 is in the desired form for use (e.g., filtered plasma), the testing sample 540 can be divided into volumes for further processing.

[0071] Aliquoting a testing sample 540 into multiple volumes may be desired when conducting a panel of assays or when conducting replicate measurements. Various embodiments of the diagnostic system 110 contemplate dividing the testing sample 540 into equal or non-equal volumes within the cartridge 114 for further processing.

[0072] FIG. 6 illustrates an example of a testing sample 540 (shaded) that has been divided into equal volumes within the cartridge 114. An example method of dividing of the testing sample 540 can involve the use of a pump (not shown). For example, a pump may be provided as a component of the diagnostic instrument 112 to assist in controlling the movement of the testing sample 540 into the aliquoted volumes 610 within the cartridge 114. For example, the pump can create a vacuum within a portion of the cartridge 114 that can drive the testing sample 540 into the aliquoted volumes 610. In embodiments, it is contemplated that the particular pump can be chosen to control the accuracy and precision of the division of the testing sample 540 into aliquots.

[0073] It is further contemplated that a sensor (not shown), such as an optical sensor, can be used in conjunction with the pump to accurately position the testing sample 540 within the cartridge 114. The sensor can be a component of the diagnostic instrument 112 and may be positioned in such a way that it can detect the location of the testing sample 540 within the cartridge 114. For example, the sensor may be used to detect a transition between the presence of a fluid (e.g., the testing sample 540 or any other fluid) as compared to the presence of air or the lack of presence of the fluid. Additionally, it is further contemplated that feedback from the optical sensor can be translated into directions to tell the pump to stop or move the sample further.

[0074] The step of processing a sample 400 can include the sub-step of mixing the testing sample with reagents 408. Various embodiments of the diagnostic system 110 contemplate that a portion within the cartridge 114 can hold and store reagents 710 for a particular diagnostic test, as illustrated in FIG. 7.

[0075] FIG. 7 is an illustration of components used in mixing the testing sample 540 with reagents 710 within a cartridge 114. The reagents 710 may be selected and measured into appropriate amounts depending on the intended purpose or goal of the diagnostic test. The pre-measured volumes of reagents 710 can be situated in various designated portions of a cartridge 114 for storage and use, such as in compartments, wells, and channels.

[0076] Reagents 710 may include an assay composition, beads, antibodies, binding partners, ligands, receptors, or detection label. Upon mixing reagents 710 with the testing sample 540, a testing sample-reagent mixture 730 can be formed.

[0077] Example assay compositions may include a biomarker that can attach to a targeted analyte. For example, 5-Fluorouracil (5-FU) is widely used in cancer patients to treat tumors including, but not limited to, colorectal, head and neck, stomach and breast carcinomas. 5-FU is most often administered systemically, but is also applied topically to treat some forms of pre-cancerous and cancerous skin disorders. In the case of 5-FU overdoses, a reagent with a biomarker specifically designed to attach to 5-FU may be provided. Further discussion of the biomarker for 5-FU may be found in PCT Application No. PCT/US12/67353, which is hereby incorporated in its entirety by reference.

[0078] With the assistance of a pump, the reagents 710 can be combined with the testing sample 540 within the cartridge 114. For example, aliquoted volumes 610 of the testing sample 540 can be moved along a mixing flow path 720 into a portion of the cartridge 114 holding the reagents 710, such as mixing well or a channel, as illustrated in FIG. 7. Within the portion of the cartridge 114 holding the reagents 710, an aliquoted volume 610 of the testing sample 540 can be supplied, so that the reagents 710 and the testing sample 540 within a testing sample-reagent mixture 730 can properly interact with each other in preparation for the diagnostic test analysis.

[0079] The testing sample-reagent mixture 730 can optionally include a reagent-reacted testing sample, or detectable complex 740, unreacted testing sample 750, and unreacted reagent 760. The detectable complex 740 can form in the mixing sub-step 408 and/or the incubating sub-step 410. The detectable complex 740 can have a labeled analyte attached, directly or indirectly, to a solid phase medium, such as a bead. The detectable complex 740 may include a detection label that can be read for analysis of the diagnostic test. For example, an ECL detection unit in a diagnostic system 110 may detect information about a detectable complex 740 by detecting a detection unit attached to an analyte. The

unreacted testing sample 750 and the unreacted reagent 760 remain in the testing sample-reagent mixture 540 until removed or reacted.

[0080] In embodiments herein, the testing sample 540 and reagents 710 are preferably mixed thoroughly to create a homogeneous testing sample-reagent mixture 730 for diagnostic test accuracy. A homogeneous testing sample-reagent mixture 730 can refer to a testing sample-reagent mixture 730 that includes a maximum amount of analyte or antigen in the testing sample 540 being bound to the reagents 710, such that a maximum amount of detectable complex 740 is formed. A pump can be provided assist in agitating the combined testing sample-reagent mixture 730 within the cartridge 114 by creating movements (e.g., back and forth) to produce a homogeneous testing sample-reagent mixture 730.

[0081] The step of processing a sample 400 can include the sub-step of incubating the testing sample-reagent mixture 410. Various embodiments of a diagnostic system 110 contemplate incubating the testing sample-reagent mixture 730 once a homogeneous testing sample-reagent mixture 730 is achieved. The testing sample-reagent mixture 730 can be incubated by an incubator to allow formation of detectable complexes 740 from the unreacted sample 750 and the unreacted reagent 760 within the testing sample-reagent mixture 730. The testing sample-reagent mixture 730 can be incubated by an incubator apparatus that may be a component of the diagnostic instrument 112.

[0082] FIG. 8 is an illustration of an example cartridge 114 positioned on an example incubator 810 within an example instrument 112. As illustrated, the cartridge 114, which includes a homogeneous testing sample-reagent mixture 730, can be positioned near the incubator 810 within the instrument 112. For example, the cartridge 114 can be placed on the incubator 810 such that a lower region of the cartridge 114 may be adjacent to the incubator 810.

[0083] Incubation of a homogeneous testing sample-reagent mixture 730 can assist in providing optimal temperatures for the antigens and reagents to react and/or bind with one another. The incubator 810 can include one or more sensors to provide temperature measurements of the sample-reagent mixture 730 to ensure

that a predetermined temperature is maintained. The incubator 810 can also include one or more heating and/or cooling elements to ensure that the temperature may be adjusted to maintain the predetermined temperature. For example, the incubator 810 can use a combination of heating elements, cooling elements, and sensors to provide an optimal temperature. In embodiments herein, the optimal temperature may be within a range (e.g., from about 25- C to about 42- C) or at a specific temperature (e.g., about 37⁵ C). It is contemplated that the predetermined temperature can be adjusted depending on the diagnostic test being run, as well as the reagents and sample being used. The time of the incubation can also be adjusted depending on the diagnostic test, reagents and sample being used.

[0084] Additionally, the incubator 810 can have multiple heating and/or cooling zones to heat and/or cool various portions of the cartridge 112. For example, separate heaters may be provided to heat a few zones simultaneously or consecutively. As another example, portions of the cartridge 112 can be moved to heating zones within the incubator 810 if the cartridge is moved within the instrument 112.

[0085] The step of processing a sample 400 can include the sub-step of washing the testing sample-reagent mixture 412. Various embodiments of the diagnostic system 110 contemplate washing the testing sample-reagent mixture 730 to isolate the detectable complex 740. For example, the washing sub-step 412 may remove any unreacted testing sample 760 and any unreacted reagents 760 from the testing sample-reagent mixture 730 to isolate a detectable complex 740.

[0086] By washing away the unreacted testing sample 750 and the unreacted reagent 760 from the testing sample-reagent mixture 730, the sensitivity and accuracy of the detection and analysis of the analyte or antigen (i.e., the detectable complex 740) within the diagnostic test can be increased. For example, the accuracy may be increased because the background noise can be substantially reduced by washing (e.g., the removal of the unreacted testing sample 750 and the unreacted reagent 760, both of which cause background noise). It is contemplated that substantially all of the unreacted testing sample 750 and the unreacted reagent

760 can be washed away. Examples herein provide that the unreacted testing sample 750 and the unreacted reagent 760 can be collected and contained within the cartridge 114 so that the washed sample can be introduced into a detection apparatus of the diagnostic instrument 112, thereby reducing the possibility of contamination between diagnostic tests.

[0087] In some embodiments, it is contemplated that the reagents 710 include a solid phase medium that can have a paramagnetic quality. By providing a solid phase medium that can have a paramagnetic quality, a magnet can be used in conjunction with the solid phase medium to magnetically fix a detectable complex 740 within a washing area while a rinsing fluid, such as a buffer, can be provided to remove the unwanted components and leave the detectable complex 740 behind.

[0088] FIG. 9 is an illustration of an example cartridge 114 provided with a magnet 910 for use in an example washing sub-step 412. FIG. 9 includes a cartridge 114 with a magnet 910 holding a detectable complex 740 in place within a cartridge 114. Rinsing fluid 920 is also provided to wash away any unreacted testing sample 760 and any unreacted reagents 760 from the testing sample-reagent mixture 730 to expose a detectable complex 740.

[0089] The magnet 910 can be a component of the diagnostic instrument 112 and can be located within the diagnostic instrument 112 such that the magnet 910 and the cartridge 114 can come in close proximity.

[0090] A pump (not shown) of the diagnostic instrument 112 can assist in washing sub-step 412. The pump can move the testing sample-reagent mixture 730 within the cartridge 114 and can introduce additional fluids stored on the cartridge 114 to assist in rinsing. A sensor (not shown) may also assist in displacing and positioning fluids within the cartridge 114. It is also contemplated that during the washing of the testing sample-reagent mixture 730, incubation can also occur. For example, the incubator 810 may be located between or adjacent to the cartridge 114 and the magnet 910.

[0091] The step of processing a sample 400 can include the sub-step of analyzing a detectable complex in at least one detection apparatus 414. Analyzing the detectable complex can be done by using ECL technology to detect the detectable complex 740.

[0092] FIG. 10A illustrates a detection apparatus 1010 within a diagnostic instrument 112. The detection apparatus 1010 can be connected to a cartridge 114 via a fluidic pathway 1020. In example embodiments, a detectable complex 740, as prepared in the cartridge 114 through sub-steps 404 through 412, can travel from the cartridge 114 via the pathway 1020 to the detection apparatus 1010.

[0093] It is contemplated that there may be more than one detection apparatus 1010 in a diagnostic instrument 112 or within a diagnostic system 110. In example diagnostic systems 110, detection apparatuses 1010 can be configured to meet different desired detection and analytical goals and to accommodate the diagnostic test being run. The type of detection and analysis can also vary depending on many factors, including, but not limited to, the diagnostic test being run and the desired specificity and sensitivity for the component being detected. The detection apparatus can use many different types of detection including ECL detection, chemiluminescence detection, fluorescence detection, time resolved fluorescence detection, fluorescence polarization detection, radiolabel detection, electrochemical detection, magnetic label detection, enzyme-linked immunosorbent assay detection, etc.

[0094] ECL has been described in detail in the following U.S. patents: 5,714,089, 6,165,729, 6,316,607, 6,312,896, 6,808,939, 6,881,589, 6,881,536, and 7,553,448, each of which is herein incorporated by reference in its entirety. FIG. 10B is an illustration of a cross section of an example ECL detection apparatus 1010 in a diagnostic system 110. The ECL-detection apparatus 1010 can include at least two electrodes 1012, 1014 separated by a gasket 1016 contained within a base 1018 that can be mated with a top 1020. A measurement containment area 1015, where the ECL detection can occur, can be formed in part by the arrangement of the gasket 1016 and the at least two electrodes 1012, 1014. The ECL detection apparatus

10 10 can be a flow cell that also includes fluid ports to introduce a fluid for detection and a light source to assist in detecting a targeted analyte within the sample.

[0095] Typically, the ECL can operate as a flow cell so it is necessary for fluids to be introduced and extracted from the measurement containment area 10 15 to set up the ECL reaction and flush out the ECL reagents. The measurement containment area 10 15 can be a sealed volume with at least two fluid ports that can allow fluids to be pumped in and out of the sealed volume.

[0096] It is contemplated that the detectable complex 740 may include an ECL label bound to a magnetic bead, and the presence of the ECL label can be detected by ECL. It is contemplated that the number of ECL labels and/or the presence or absence of the ECL labels within the biological sample-reagent mixture can be detected using the ECL detector.

[0097] ECL signals may be generated by a redox reaction between an ECL label and a substrate. In certain embodiments, an ECL label can be a ruthenium-containing reagent. One example of a suitable ECL label is Tris(bipyridine)ruthenium(II) $[\text{Ru}(\text{bipy})_3]^{2+}$, also referred to as TAG. In certain other embodiments, the substrate can be tripropylamine (TPA). Some advantages of the method of using ECL-based assays are they are rapid and sensitive. It is contemplated that for other detection methods, the detection label and reagents can be varied as necessary to satisfy the requirements of the detection method.

[0098] Referring again to FIG. 2, method 200 may include the step of discarding a sample 500. Example procedures for discarding portions of a sample 500 (i.e., unreacted testing sample and rinsing fluid) may include discarding the portion of the sample 500 within a portion of a cartridge 114. FIG. 11 illustrates an example embodiment cartridge 114, which can include a discard reservoir 1110 to accept discarded unreacted testing sample and rinsing fluid via a flow channel 1120.

[0099] Method 200 may include the step of outputting results 600. Example procedures for outputting results 600 may include gathering the processing sample results from step 400 and outputting the results via the diagnostic instrument 112.

FIG. 12 illustrates an example diagnostic instrument, which can include various devices for outputting the results. As illustrated in FIG. 12, the diagnostic instrument 112 may include a display panel 1210 for displaying results, a port 1220 for connection to external media, such as a Universal Serial Bus (USB) port, a firewire port, etc., a wired or wireless electronic connection 1230 to transmit results via electronically to another location, such as a wireless internet transmitter, an Ethernet cable, etc., a print device 1240 to print out the results, such as a printer, or a media writing device 1250 to create a media format, such as a Compact Disk (CD).

[00100] **G. Embodiments**

[00101] FIG. 13 is an illustration of a diagnostic system 110 having a diagnostic instrument 112 fluidically connected to a cartridge 114 by way of fluidic pathways 134. The arrows indicate an example of a substantially single direction of flow for the materials travelling through the diagnostic system 110. In some embodiments, the disposal of processed materials can be returned to the cartridge without cross-contamination between tests run on the diagnostic instrument due to a substantially single direction of flow that the fluids in the diagnostic test follow.

[00102] The diagnostic system 110 can include a cartridge 114 that is self-contained and compact. Various embodiments of the diagnostic system 110 contemplate that a sample can be introduced into a cartridge 114 where it can be processed within the cartridge 114 during a diagnostic test. The cartridge 114 can be introduced into a diagnostic instrument 112 having the mechanical and electrical components necessary to run the diagnostic test and detect results using detection technology contained within the diagnostic instrument 112. The components and methods associated with the cartridge 114 will be described in more detail in the following disclosure.

[00103] The cartridge 114 can be configured to perform the steps of a diagnostic test completely within the diagnostic system 110 in conjunction with a diagnostic instrument 112 of the diagnostic system 110. For example, the cartridge 114 can store and hold all necessary reagents and materials necessary to perform a particular diagnostic test, such as an assay. The cartridge 114 can also be

configured to store the reagents and materials in separate compartments, and provide air-tight and liquid-tight seals that can assist in diagnostic test functions, which will be described in further detail in the following disclosure.

[00104] The cartridge 114 can also be configured to receive a biological sample for processing and analysis during the diagnostic test. Through cooperative mechanisms with the diagnostic instrument 112, the biological sample can be prepared and processed completely within the diagnostic system 110 without the requirement for end-user input, once the sample is collected and introduced into the cartridge 114. The cooperative mechanisms between the cartridge and the diagnostic instrument of the diagnostic system also will be described in further detail in the following disclosure.

[00105] The cartridge 114 can also be configured to retain and collect substantially all of the processed sample, reagents, and materials used in the diagnostic test for disposal once the diagnostic test is completed. This not only provides added convenience of being self-contained but it also prevents and/or reduces cross-over or contamination between different diagnostic tests run on the same diagnostic instrument. The mechanisms involved in collecting the used materials also will be described in further detail in the following disclosure.

[00106] Examples of certain embodiments of a cartridge 114 are disclosed in co-pending U.S. Design Application Nos. 29/420,961 and 29/420,967, both filed on May 15, 2012, and each of which is herein incorporated by reference in its entirety. Images contained within those disclosures prescribe exemplary diagnostic cartridges of the diagnostic system, and designs thereof, which relay both the function and form, and the connection between the product, the user, and the environment. Such images merely represent exemplary cartridges, diagnostic systems, and the present disclosure is not limited to these particular designs.

[00107] FIG. 14A illustrates a perspective view of a body and a cover of a cartridge 114 of a diagnostic system 110. Various embodiments of a cartridge 114 contemplate having a cover 420 and a body 422 that mate together to form the cartridge 114.

[00108] FIG. 14B illustrates a perspective view of an example of an embodiment of a cartridge 114 of a diagnostic system 110. The cover 420 can have at least one retaining feature 424 to facilitate connecting the cover 420 to the body 422. For example, the at least one retaining feature 424 can include a snap fit on one or both ends of the cover 420.

[00109] FIGS. 15A and 15B illustrate the at least one retaining feature 424, and also show the examples of a cover 420, which can have a pull on each end of the cover 420 to ensure a secure fit to the body 422. It is contemplated that additional retaining features known in the art can be designed and included in the cover 420 to assist in securing the cover 420 to the body 422, including, but not limited to, press fits, tabs, spring locks, and over-molded magnets.

[00110] Various embodiments of the cartridge 114 contemplate that the cover 420 can have a flat area which makes contact with and covers the body 422, effectively covering and protecting the components of the body 422. No liquid or air tight seals are needed between the cover 420 and the rest of the cartridge 114. An optical machine-readable label 118 can be positioned on a portion of the flat area of the cover 420 for identification as previously discussed and as part of one of many failsafe mechanisms incorporated into the diagnostic system 110.

[00111] The cover 420 may also make the cartridge 114 as a whole look more aesthetically pleasing. The cover 420 can be injected molded out of a variety of sturdy materials, such as, poly(methyl methacrylate) (PMMA), polycarbonate (PC), polycarbonate/ Acrylonitrile butadiene styrene (PC/ABS) blends. It is contemplated that other materials may be used to form the cover 420 depending on desired specifications and manufacturing goals for the disposable cartridge 114, such as, for example, a polycarbonate/acrylonitrile butadiene styrene such as GE Cycloy HC 1204HF, a polycarbonate such as Sabic Lexan (PC) EXL91 34, polyethylene terephthalate (PET), polypropylene (PP), polyvinyl chloride (PVC), and Teflon. It is contemplated that other known methods of forming the cover 420 can be employed, including, but not limited to casting, rotational molding, thermoforming, compression molding, and injection molding.

[001 12] With reference to FIG. 14B, functionally, the cover 420 can assist in guiding a sample holder (not shown), such as a commercially available VACUTAINER® sample holder, onto at least one needle 428 integrated into the body 422 and used during processing of a diagnostic test. The cover 420 also serves to protect an operator from the sharp point of the at least one needle 428.

[001 13] Various embodiments of the cartridge 114 contemplate having structural and functional features useful for filtration of a sample, assay processing regions (each region also referred to as a cartridge assay replicate or CAR), probe wash areas and draw reservoirs filled with ECL read buffer (can also be referred to as a read buffer filled reagent handling station (RHS)), and a pump storage fluid filled RHS. Certain embodiments contemplate that some components of the cartridge 114 can be attached to the body 422, including, for example, the cover 420, a filtration module 330, at least one needle 428, and multiple seals.

[001 14] The cartridge 114 may include a sample holder mount. Various embodiments of a cartridge 114 contemplate having a sample holder mount 430 and having a sample holder 116. For example, the body 422 can be configured to accommodate the mounting of an industry standard sample holder (i.e., VACUTAINER®), or similar sample holder 116, which can connect to a fluidic pathway of the diagnostic system 110. As previously described, the sample can be a biological sample such as blood, plasma, urine or sputum.

[001 15] In certain embodiments, the sample holder mount 430 can be configured to guide a sample holder 116 onto at least one needle 428 to establish fluidic communication, such as, for example, with a diagnostic instrument 112. The guide features 434 can also facilitate the piercing of the desired portion of the sample holder's septum 438 by physically constraining the radial motion of the sample holder 116. The at least one needle 428 can be mounted on the framework 432 to facilitate its insertion into the septum 438 of a sample holder 116, which would thereby facilitate, establish and maintain the fluidic connections between the at least one needle 428 and a diagnostic instrument 112.

[001 16] Various embodiments of the diagnostic system 110 contemplate having a filtration module 530, such as that previously described in method 400 and depicted in FIG. 5, in fluidic communication with the sample holder 116 and a cartridge 114. Various embodiments of the diagnostic system 110 also contemplate a method of filtering a sample with the filtration module 530 within a cartridge 114. Examples of suitable filtration modules and methods of filtration are described in the '253 application and the '041 PCT application. The filtration module 530 can be designed such that it maintains the compact size and self-contained nature of the cartridge 114.

[001 17] FIG. 16 is an illustration of a flow chart for an example instrument-driven work flow. A user or operator can draw blood into a blood tube using standard practices. In the instrument-driven mode, the user or operator (in either order) can insert the blood tube into the cartridge and can enter the patient ID and operator ID into the diagnostic instrument. The diagnostic instrument, after reading the panel information from the cartridge, may ask the operator to confirm the panel. The user or operator can insert the cartridge into the diagnostic instrument. The diagnostic instrument or analyzer, after reading the panel information from the cartridge, may ask the user to confirm the panel. Afterwards, the sample is processed and results are presented, for example, in roughly 15 minutes.

[001 18] FIG. 17 is an overview illustration of a closed fluidic path 710 (see, e.g., 710a, 710b, 710c) between a diagnostic instrument 112 and a cartridge 114 of a diagnostic system 110. Various embodiments of a diagnostic instrument 112 contemplate having mechanical and electrical components that are connected fluidically to a cartridge 114 by a closed fluidic path 710. For example, the closed fluidic path 710 can fluidically connect a cartridge 114 via a first probe 712 to optional features along the closed fluidic path 710, such as a non-ECL detection module 910 via path 710a, at least one ECL detection apparatus 1010, a pump 810 via path 710b and returning to the cartridge 114 via path 710c and a second probe 714. The closed fluidic path 710 provides a pathway through which diagnostic materials, such as a biological sample and dry and liquid reagents, can be withdrawn from the cartridge 114, and can travel through the diagnostic instrument 112. After

processing, the processed reagents and other waste materials can be returned to the cartridge 114 using a substantially single direction of flow (indicated by arrows).

[001 19] FIG. 18 is an illustration of an example of an internal standard (IS), non-ECL detection apparatus 910 that can be provided. Various embodiments of the diagnostic system 110 can contemplate a non-ECL detection apparatus 910 for use as a failsafe mechanism to ensure the precise and accurate function of the diagnostic system 110. In some embodiments, one such failsafe mechanism can include an internal standard (IS) non-ECL detection apparatus 910 to the diagnostic system 110. An IS can be a substance that can be added in a constant quantity to samples and calibration standards in an assay or analysis. An IS can be a substance that is very similar, but not identical to the substance of interest in the sample. The effects of assay construction should be the same for the IS as the substance of interest.

[001 20] The non-ECL detection apparatus 910 can include a housing 912 with a tubing assembly 920 within the housing 912 that can carry a sample to be analyzed. As the sample passes through the housing 912, a laser 924 can be directed through a filter 926 and the laser light can be reflected through the sample. The reflected light can be used to detect the presence of a particular analyte within the sample as it flows through the non-ECL detection apparatus 910. For example, an IS can be used within the detection analysis.

[00121] One purpose of an IS can be to identify failures that might occur during assay construction. As such, a method to implement the IS operates as a failsafe mechanism. Another purpose of an IS to correct for normal variability in assay construction. As such, the method to implement the IS operates as a means to improve precision and accuracy. Further discussion about ISs and failsafe mechanisms can be found in related application International PCT patent application filed on May 15, 2013, entitled "CLINICAL DIAGNOSTIC SYSTEMS INCLUDING INSTRUMENT AND CARTRIDGE," the application having attorney docket number 201 08.1 -PCT, which was incorporated by reference above.

[00122] While the invention has been described in detail with reference to preferred embodiments thereof, it will be apparent to those skilled in the art that variations and modifications can be made, and equivalents employed without departing from the scope of the appended claims.

WHAT IS CLAIMED IS:

1. A diagnostic system, comprising:
an instrument comprising an electrochemiluminescence (ECL) detector; and
a cartridge configured to fit within a portion of the instrument, wherein the cartridge comprises:
at least one reagent including an ECL label; and
a blood collection holder.
2. The diagnostic system of claim 1, wherein the instrument further comprises a pump, an incubator, a sensor, a magnet, and an output device.
3. The diagnostic system of claim 1, wherein the cartridge further comprises at least one blood collection holder needle, a blood collection holder structure, and closed fluidic pathways between the blood collection holder and the instrument.
4. The diagnostic system of claim 1, wherein the cartridge further comprises a filter or a discard reservoir,
wherein the filter, if present, filters plasma from whole blood, and
wherein the discard reservoir, if present gathers the at least one reagent including the ECL label and contents from the blood collection holder.
5. The diagnostic system of claim 1, wherein the blood collection holder comprises blood collection tube.
6. A system, comprising:
a diagnostic instrument comprising:
a pump;

an electrochemiluminescence (ECL) detector;
an incubator;
a magnet; and
an output device; and
a cartridge configured to fit within a portion of the diagnostic instrument;
a sample holder configured to fit within the cartridge; and
a closed fluidic loop between the diagnostic instrument and the cartridge
when the cartridge is fit within a portion of the diagnostic instrument, wherein the
cartridge is configured to accept a sample from the sample holder and place the
sample in fluidic communication with the diagnostic instrument via the closed fluidic
loop.

7. The system of claim 6, wherein the ECL detector comprises:
at least two electrodes; and
a gasket, wherein the gasket separates the at least two electrodes, and
wherein a measurement containment area is formed by the gasket and the at least
two electrodes, and wherein the ECL detector measures ECL labels within the
measurement containment area.

8. The system of claim 6, wherein the incubator comprises:
one or more sensors; and
one or more heating and/or cooling elements, wherein the one or more
sensors and the one or more heating and/or cooling elements provide a
predetermined temperature to a portion of the closed fluidic channel within the
cartridge.

9. The system of claim 6, wherein the cartridge further comprises:
at least one sample holder needle; and
a sample holder structure, wherein the sample holder fits within the sample holder structure and the sample is accessible to the closed fluidic loop via the at least one sample holder needle.
10. The system of claim 6, wherein the cartridge further comprises at least one reagent including a biomarker designed to detect 5-Fluorouracil (5-FU) within the closed fluidic loop.
11. The system of claim 6, wherein the cartridge further comprises a filter within the closed fluidic loop, wherein the filter is configured to separate portions of the sample.
12. The system of claim 6, wherein the cartridge further comprises a discard reservoir within the closed fluidic loop, wherein the discard reservoir is configured to hold contents of the closed fluidic loop, and wherein the system is a self-contained diagnostic system.
13. A method of providing Point of Care (POC) services, comprising:
providing a biological sample;
introducing the biological sample to a cartridge;
providing the cartridge to a diagnostic instrument comprising an electrochemiluminescence (ECL) detector;
mixing the biological sample with a reagent in the cartridge to form a biological sample-reagent mixture;
analyzing the biological sample-reagent mixture using the ECL detector; and

outputting the results from the analyzing step.

14. The method of claim 13, wherein the introducing the biological sample to a cartridge comprises:

inserting a blood collection holder containing the biological sample into a preconfigured area of the cartridge; and

allowing the biological sample from the blood collection holder to be available to fluidic channels within the cartridge.

15. The method of claim 14, wherein the inserting of the blood collection holder into the preconfigured area of the cartridge comprises inserting the blood collection holder into a blood collection holder mount that includes at least one blood collection needle that allows the biological sample to be available to fluidic channels within the cartridge.

16. The method of claim 13, wherein the providing the cartridge to a diagnostic instrument comprising an ECL detector comprises:

fitting the cartridge into a preconfigured area of the diagnostic instrument, wherein the preconfigured area of the diagnostic instrument is a slot in the diagnostic instrument shaped specifically for the cartridge.

17. The method of claim 13, wherein the mixing the biological sample with a reagent in the cartridge to form a biological sample-reagent mixture comprises:

mixing the biological sample with the reagent, wherein mixing moves the biological sample together with the reagent within a fluidic channel to form detectable complexes in the biological sample-reagent mixture.

18. The method of claim 13, wherein the analyzing the biological sample-reagent mixture using the ECL detector comprises:

introducing the biological sample-reagent mixture into the ECL detector;

applying a light source to the biological sample-reagent mixture within a measurement containment area of the ECL detector; and

detecting the number of ECL labels within the biological sample-reagent mixture using the ECL detector.

19. The method of claim 13, wherein the outputting the results from the analyzing step comprises:

gathering results from the analyzing step; and

outputting results to the diagnostic instrument to supply a user with the results.

20. The method of claim 13, further comprising filtering the biological sample by:

flowing the biological sample through a filtration module within the cartridge to divide the biological sample into a testing sample and a waste product.

21. The method of claim 20, wherein the flowing of the biological sample through a filtration module comprises flowing the biological sample through one or more filtration layers.

22. The method of claim 20, further comprising collecting the testing sample in a testing sample cache within the cartridge.

23. The method of claim 20, further comprising collecting the waste product in a waste product collector within the cartridge.

24. The method of claim 13, further comprising incubating the biological sample-reagent mixture by:

heating and/or cooling with one or more heating and/or cooling elements the biological sample-reagent mixture;

sensing with one or more sensors a temperature of the biological sample-reagent mixture; and

adjusting a temperature of the incubator to a predetermined temperature.

25. The method of claim 13, further comprising washing the biological sample-reagent mixture by:

positioning the biological sample-reagent mixture within a portion of the cartridge within an electromagnetic field of a magnet of the diagnostic instrument;

magnetically attracting a first portion of the biological sample-reagent mixture to the magnet; and

washing away a second portion of the biological sample-reagent mixture with a rinsing fluid to expose the detectable complex for analyzing.

26. The method of claim 13, wherein providing the biological sample comprises providing blood from within a blood collection tube, and wherein the mixing the biological sample with a reagent in the cartridge to form a biological sample-reagent mixture comprises mixing the blood from within the blood collection tube with a biomarker designed to detect 5-Fluorouracil (5-FU).

27. The method of claim 13, further comprising analyzing the biological sample-reagent mixture using an internal standard (IS) detector.

28. The method of claim 27, further comprising providing a failsafe mechanism by comparing results from the analyzing of the biological sample-reagent mixture by the IS detector with results from the analyzing of the biological sample-reagent mixture by the ECL detector.

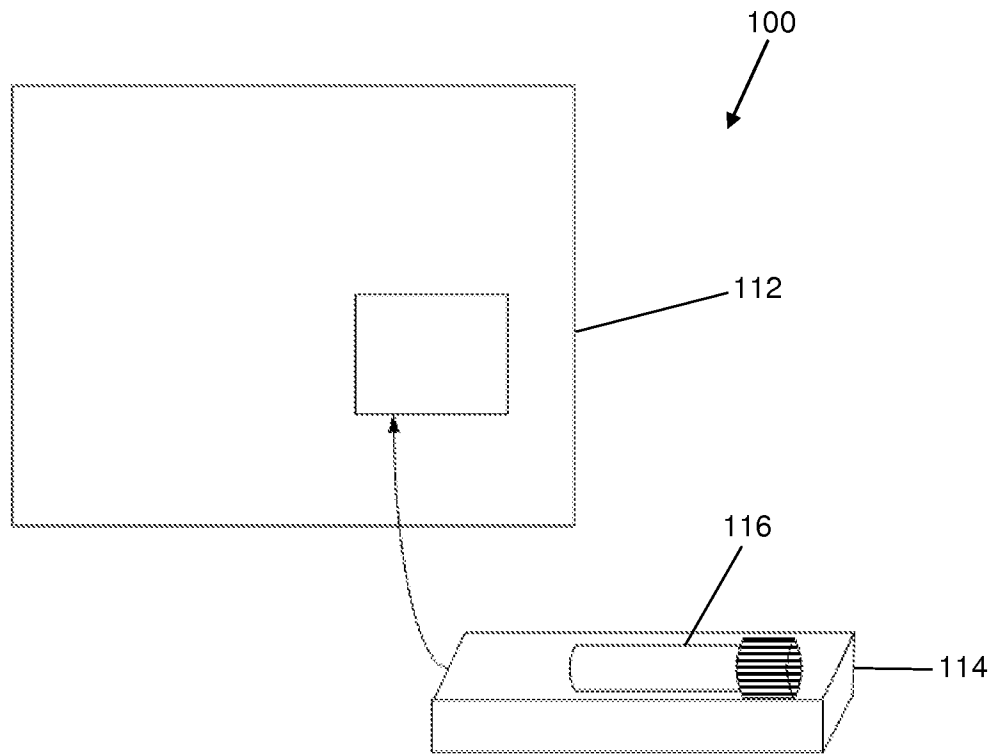

FIG. 1

200

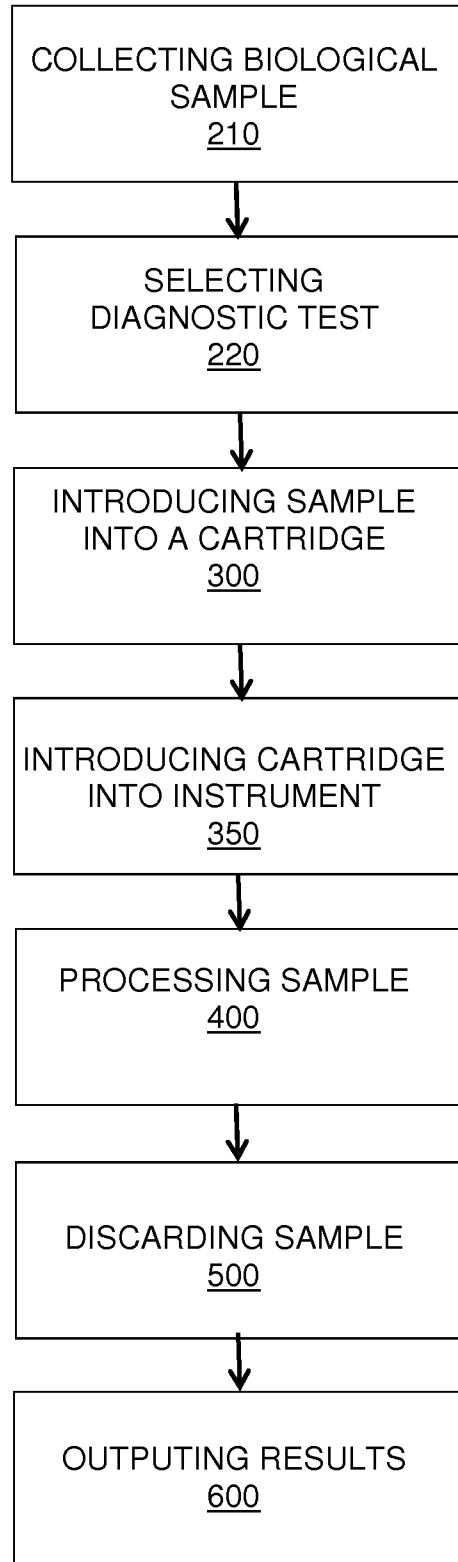

FIG. 2

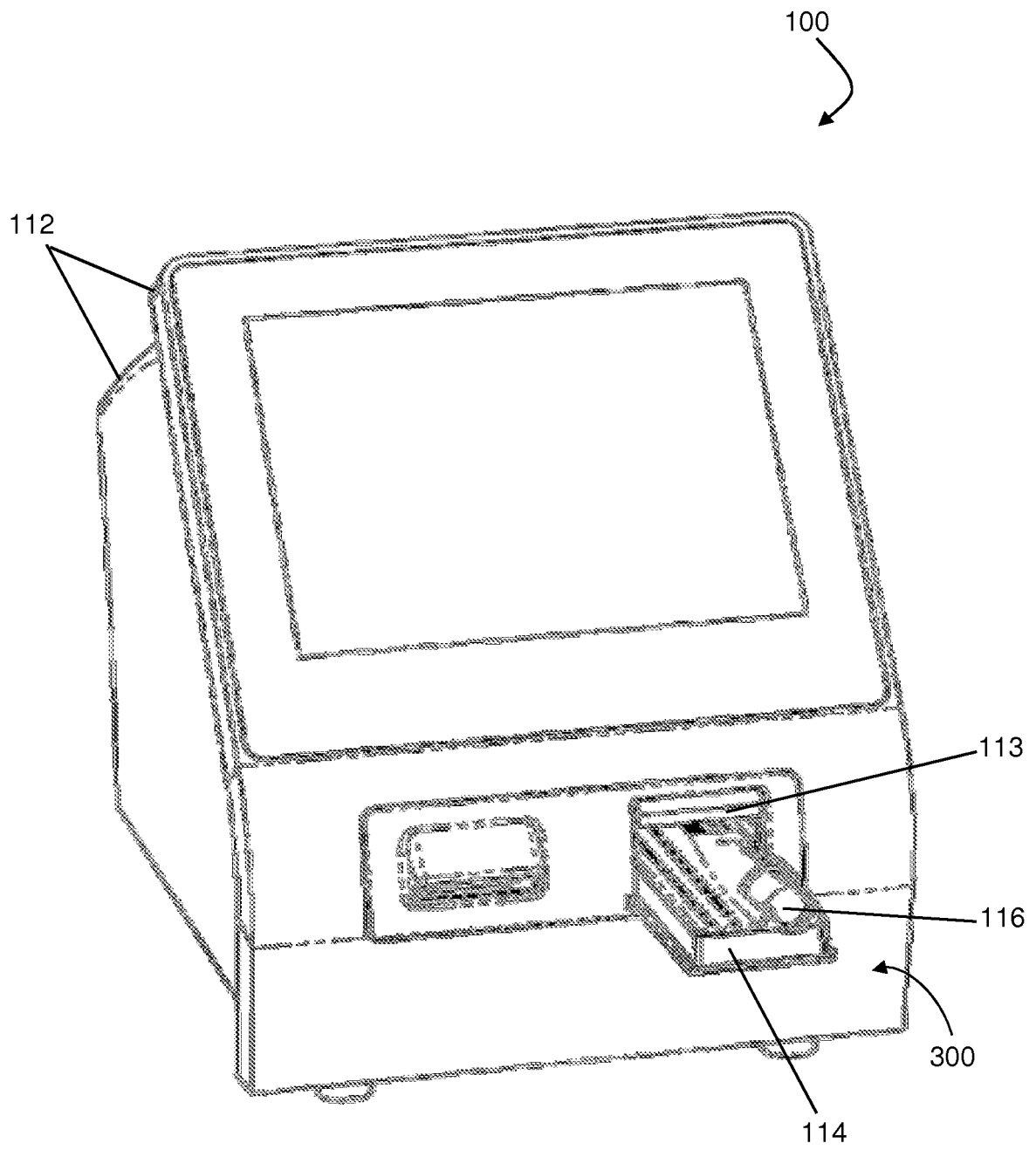

FIG. 3

400

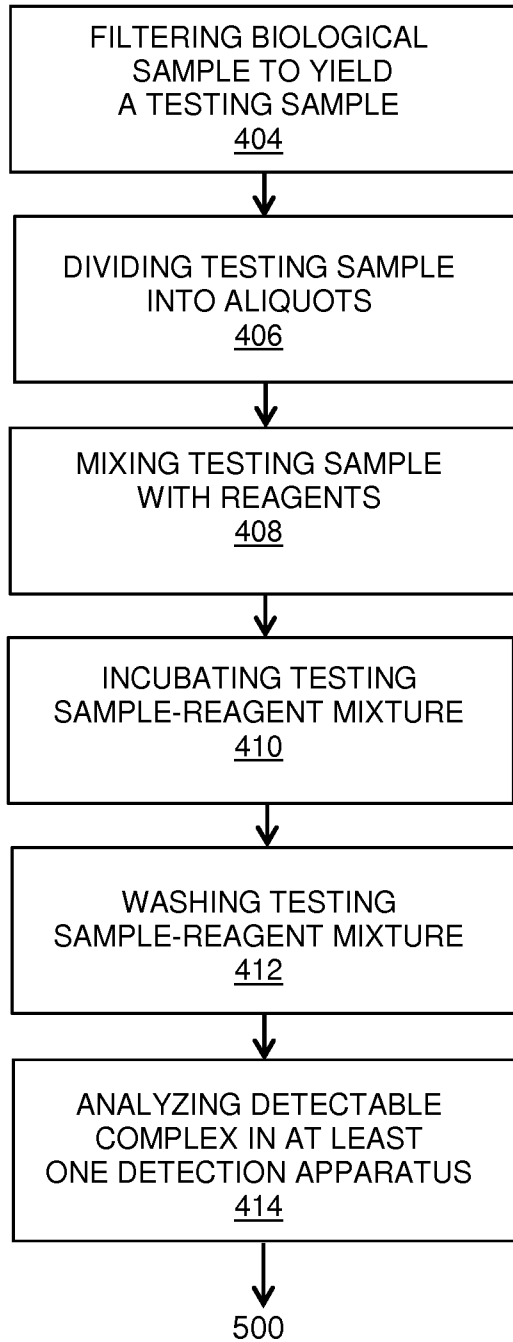

FIG. 4

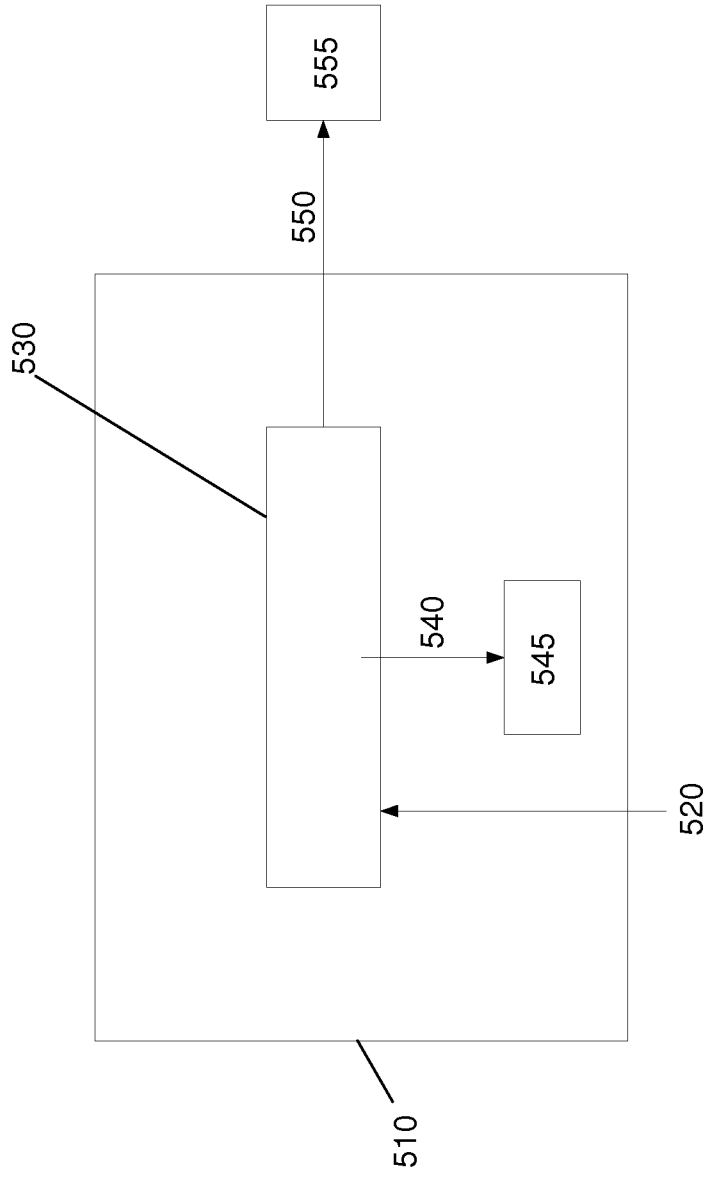

FIG. 5

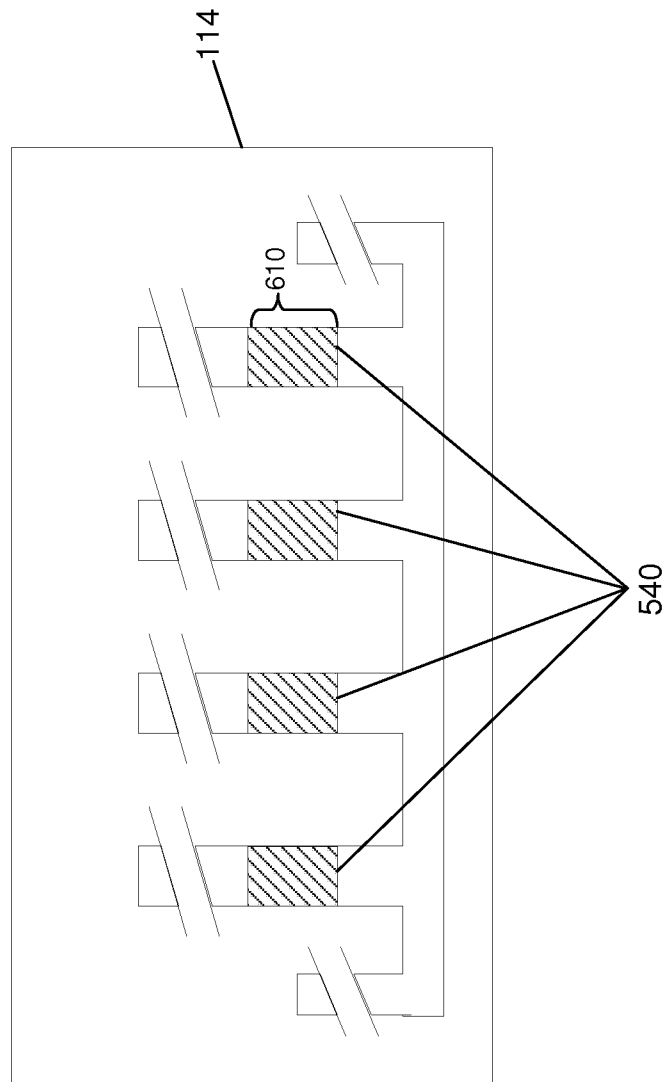

FIG. 6

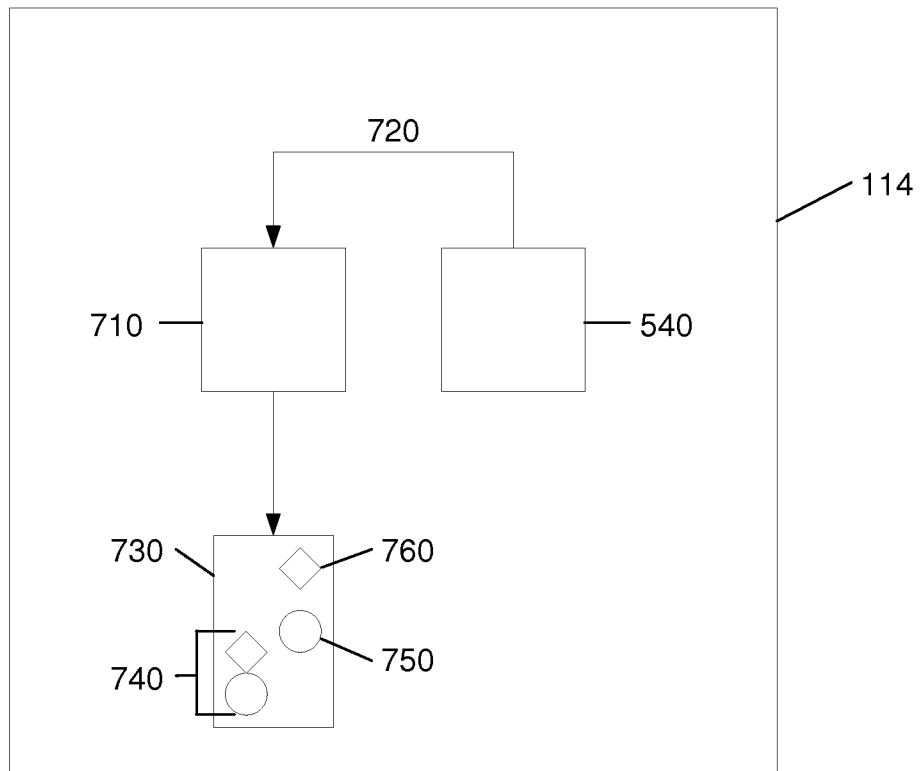

FIG. 7

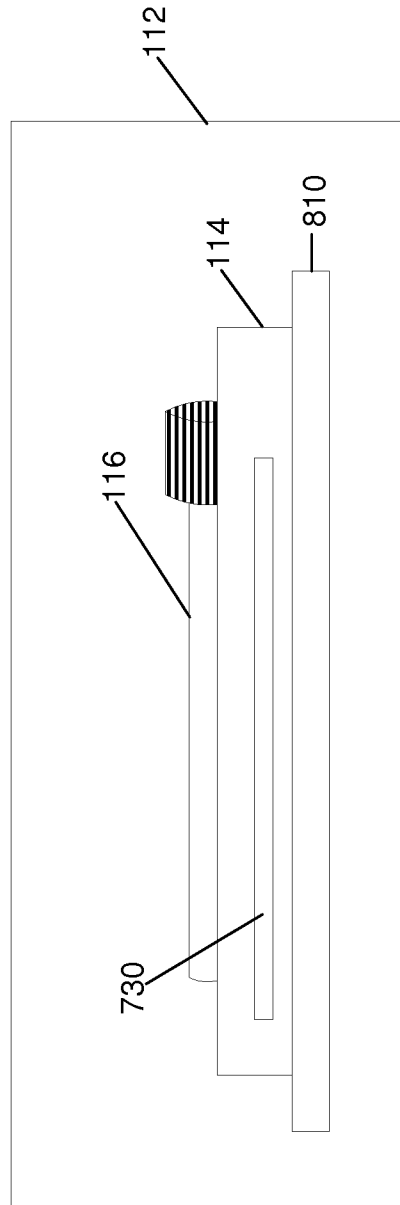

FIG. 8

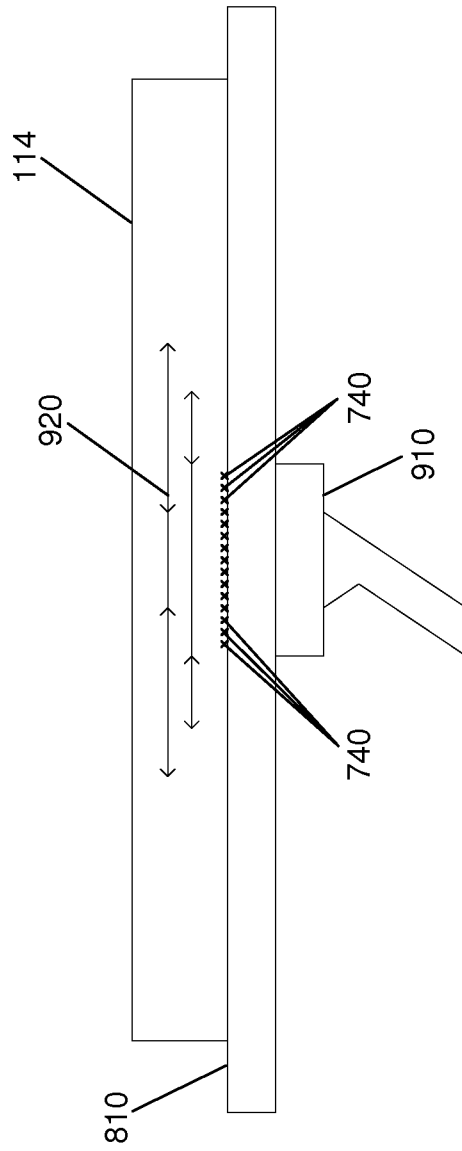

FIG. 9

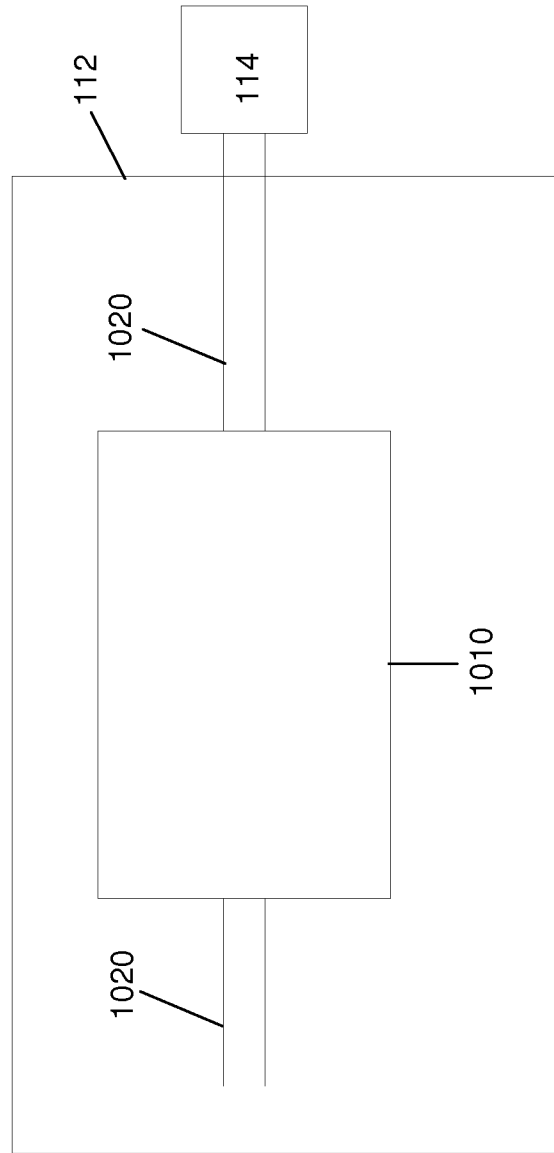

FIG. 10A

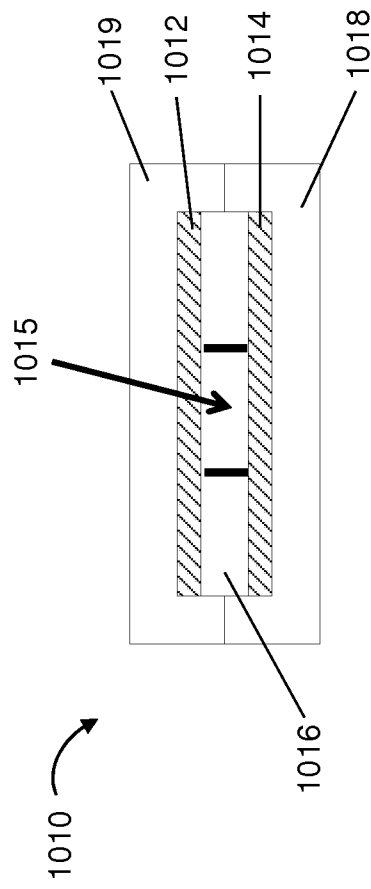

FIG. 10B

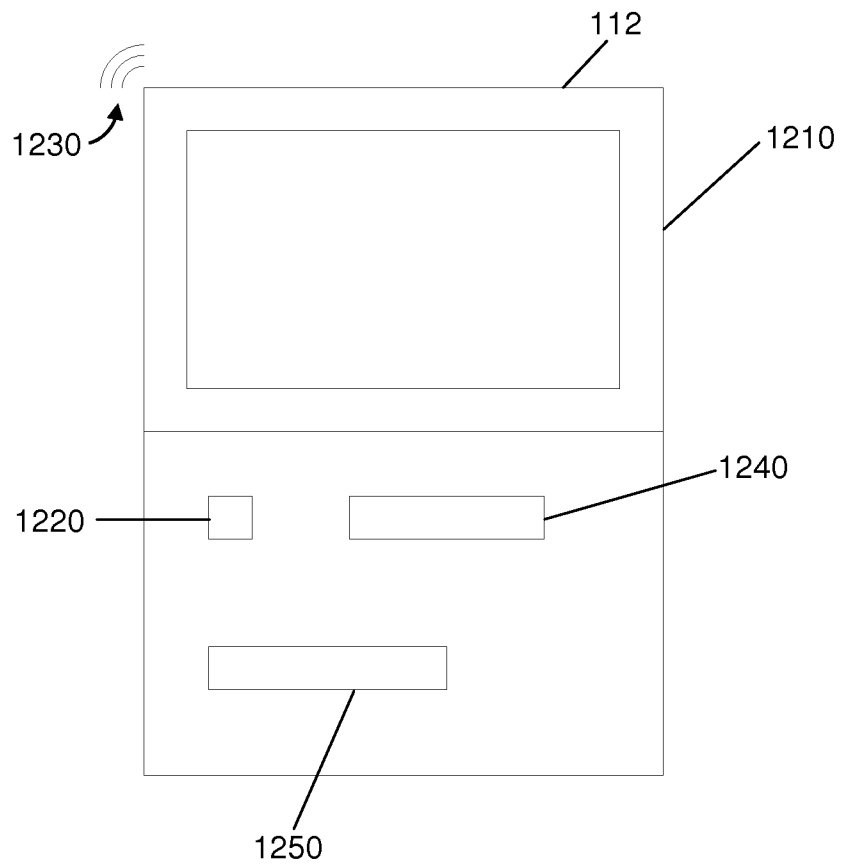

FIG. 12

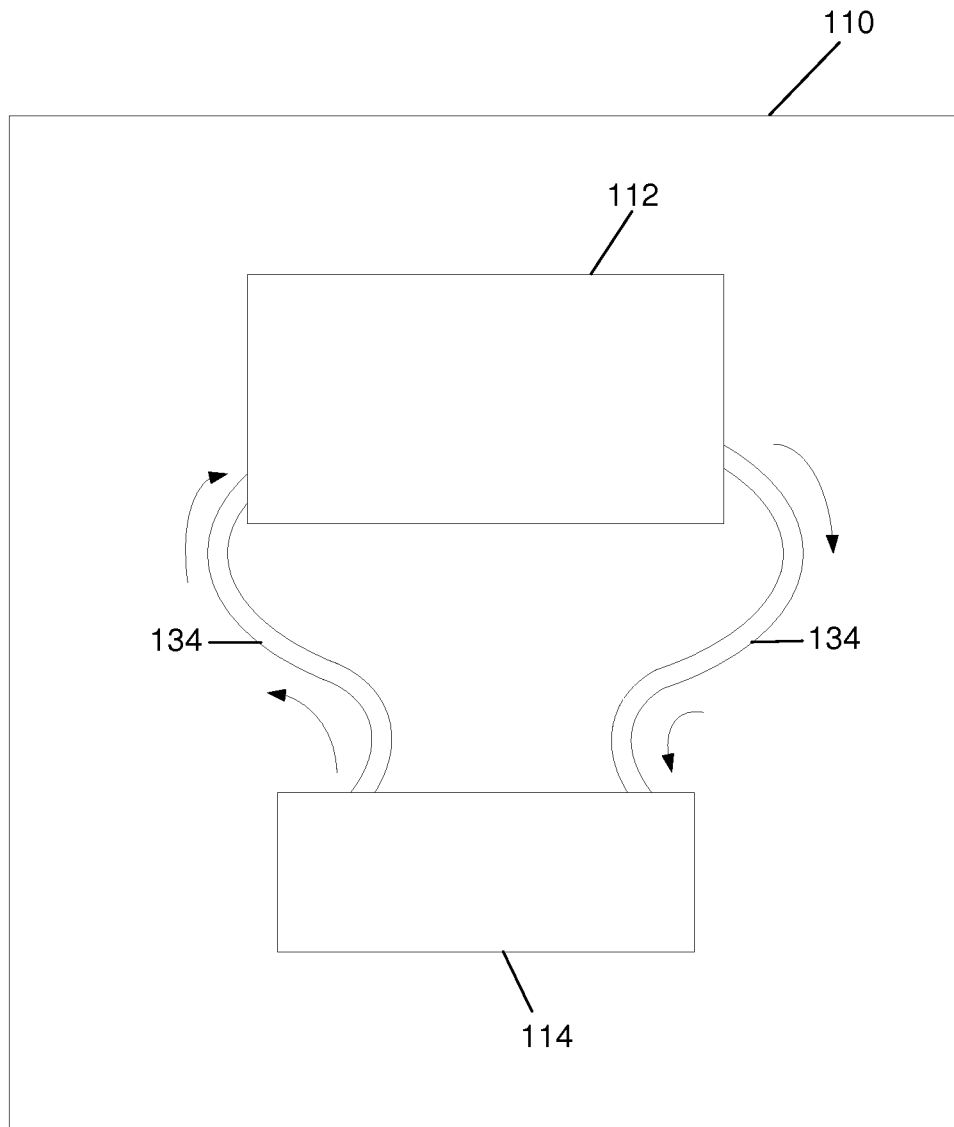

FIG. 13

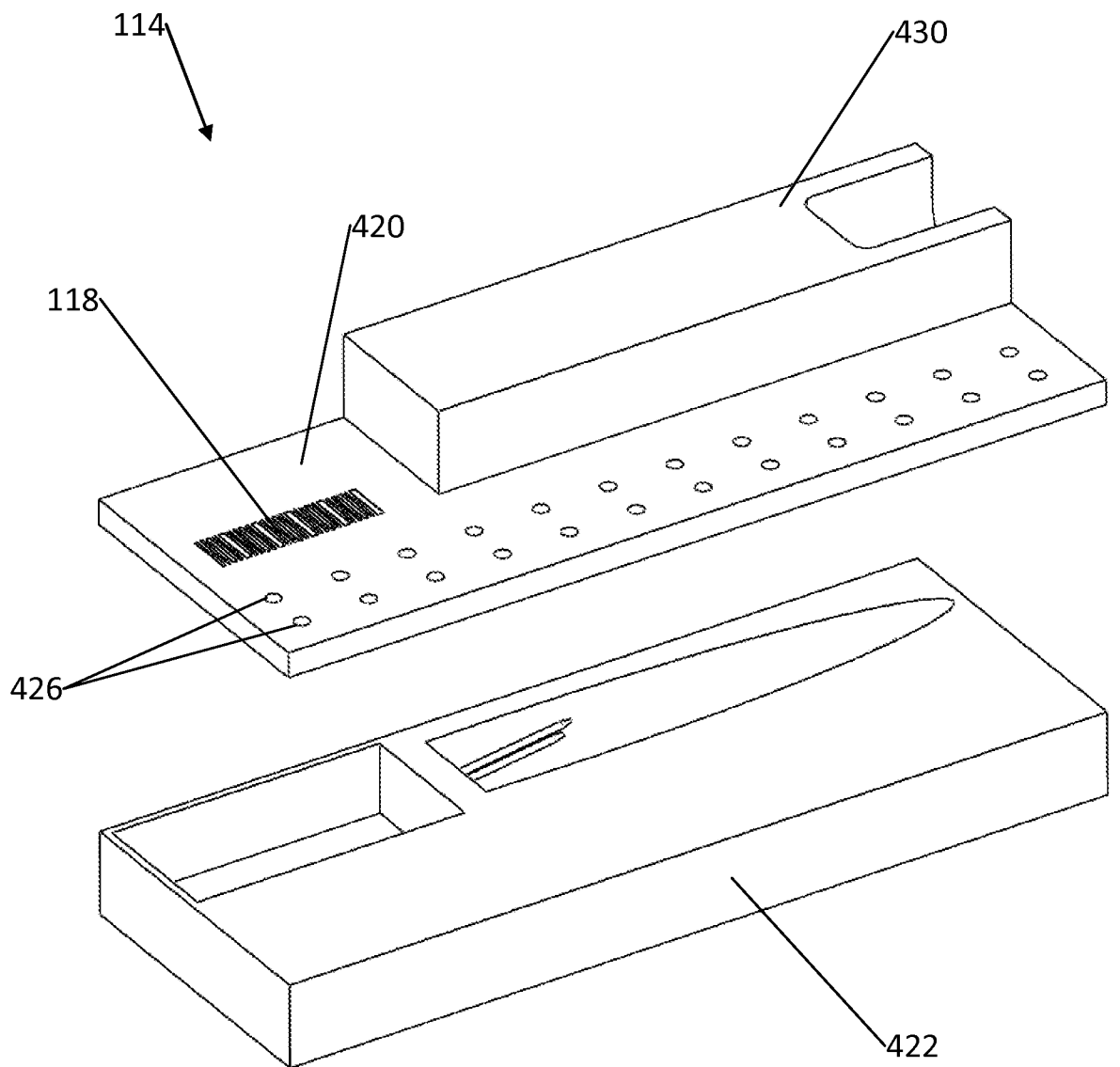

FIG. 14A

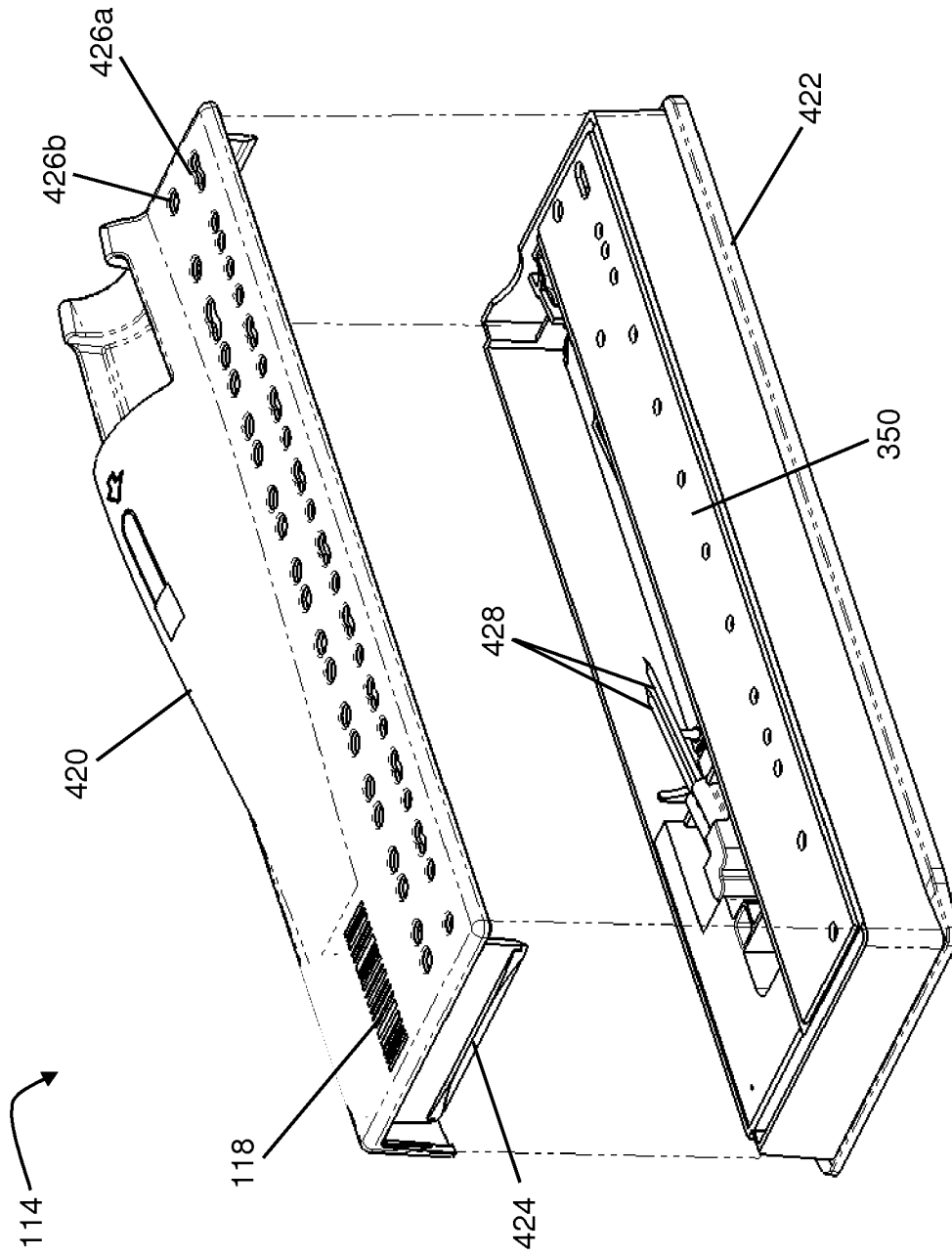

FIG. 14B

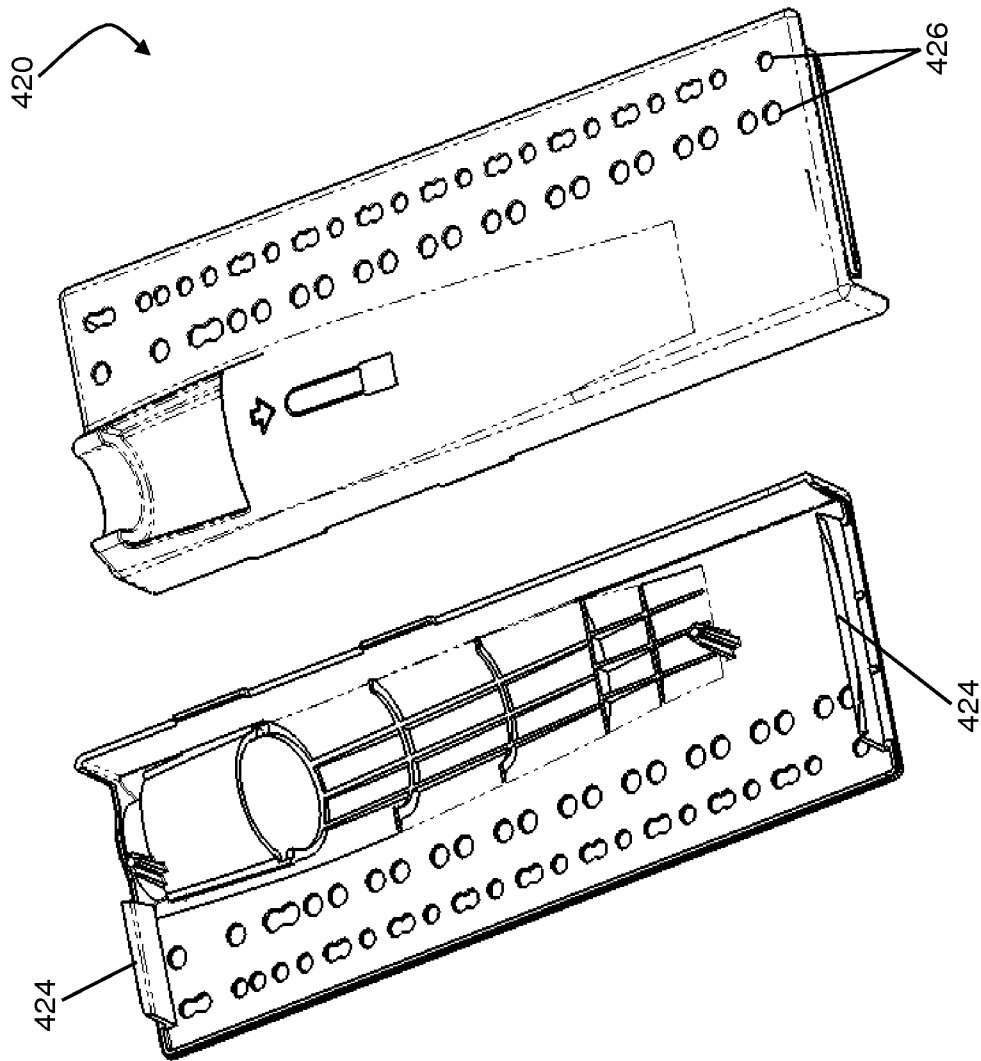

FIG. 15A

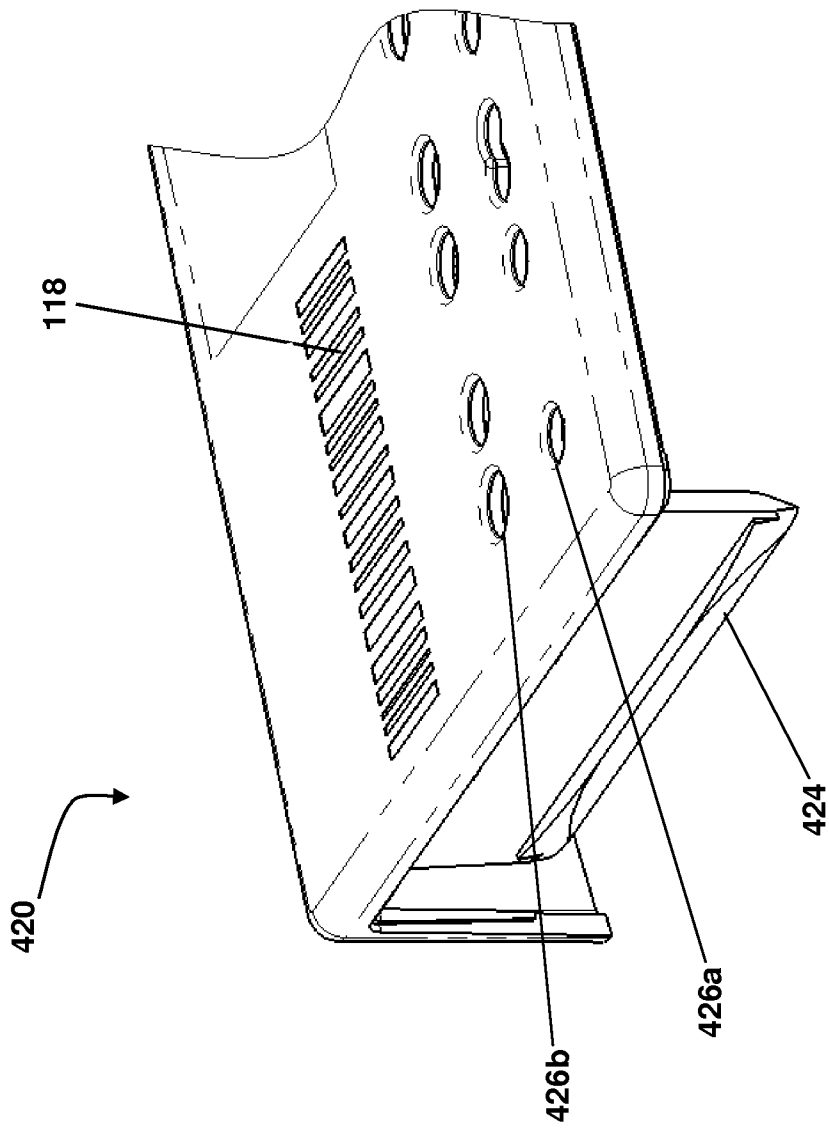

FIG. 15B

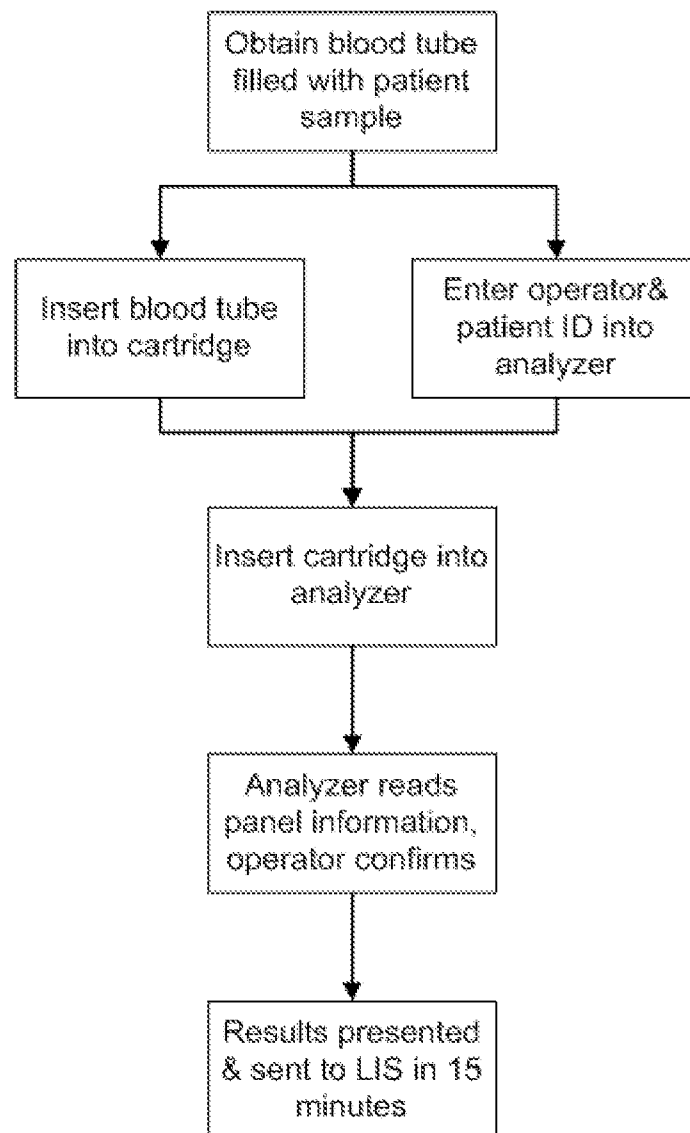

FIG. 16

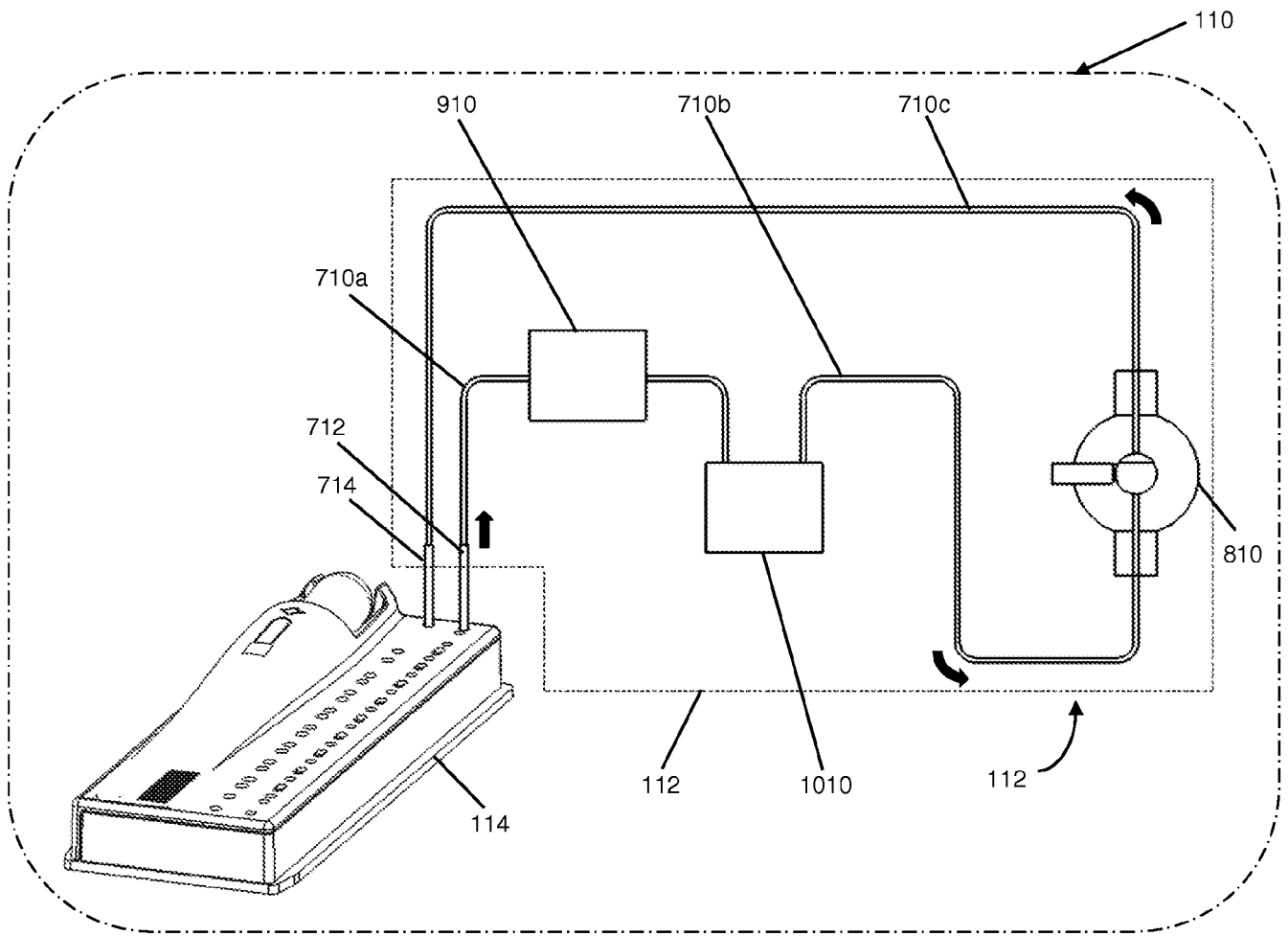

FIG. 17

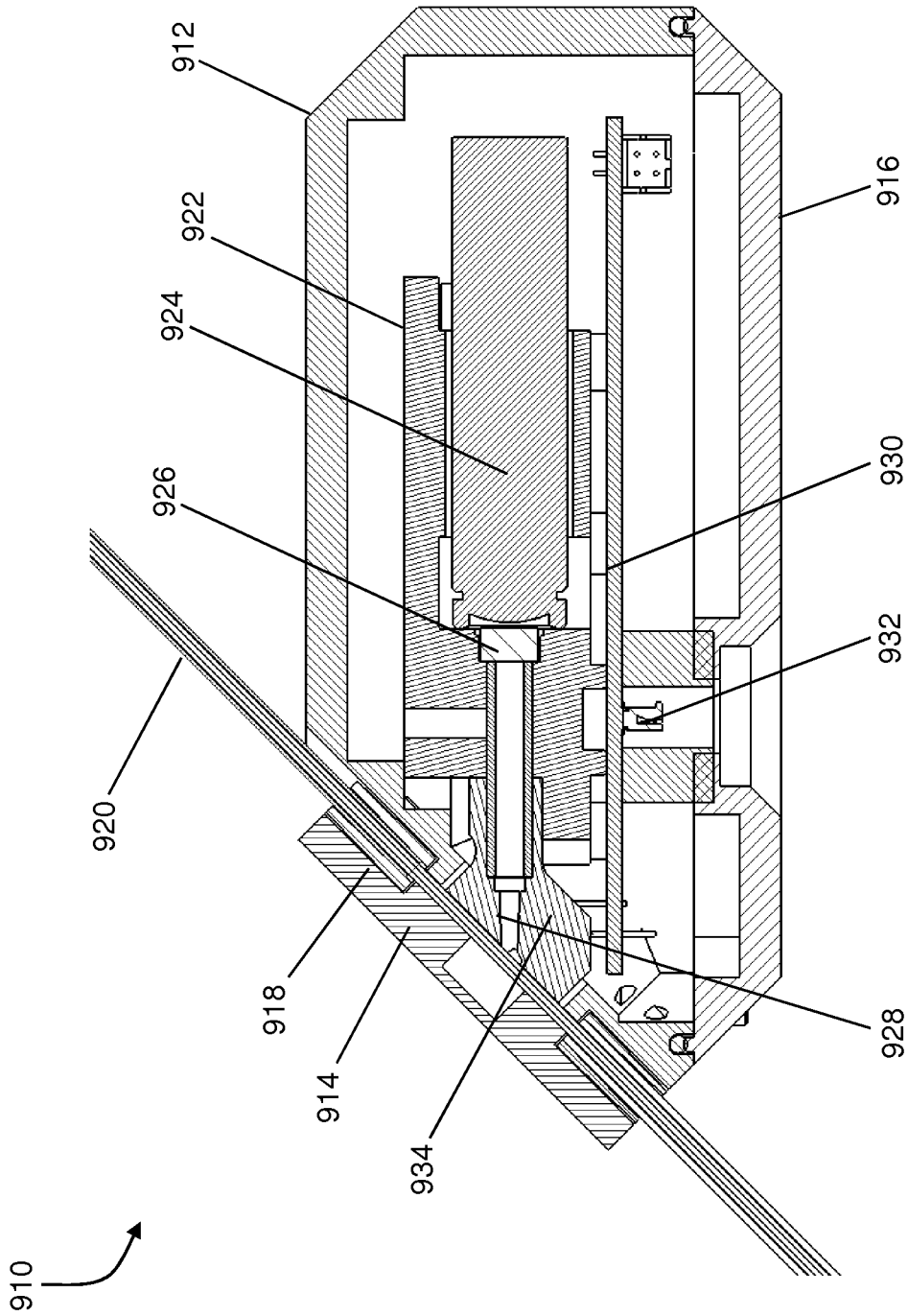

FIG. 18

INTERNATIONAL SEARCH REPORT

International application No.

PCT/US13/41255

A. CLASSIFICATION OF SUBJECT MATTER

IPC(8) - (continued on supplemental page)**USPC** - (continued on supplemental page)

According to International Patent Classification (IPC) or to both national classification and IPC

B. FIELDS SEARCHED

Minimum documentation searched (classification system followed by classification symbols)

(continued on supplemental page)

Documentation searched other than minimum documentation to the extent that such documents are included in the fields searched

Electronic data base consulted during the international search (name of data base and, where practicable, search terms used)

MicroPatent (US-G, US-A, EP-A, EP-B, WO, JP-bib, DE-C.B, DE-A, DE-T, DE-U, GB-A, FR-A); IP.com: DialogPRO; PubMed/Medline; Google/Google Scholar; Search terms used: electrochiluminescence*, ECL, detector, camera*, inspect*, cartridge*, rotor*, device*, blood*, plasma*, holder*, retain*, storage*, waste*, product*, divide*, separate*, magnet*, needle*

C. DOCUMENTS CONSIDERED TO BE RELEVANT

Category*	Citation of document, with indication, where appropriate, of the relevant passages	Relevant to claim No.
X — Y	WO 2007/002579 A2 (DAVIS, CQ et al.) January 4, 2007; paragraphs [006], [0108], [0114], [0118], [0120], [0122], [0125], [0138], [0152] [0160], [0167], [0183], [0214], [0160], [0319]	1-6, 9, 11, 13-14, 16-19, 25 ----- 7-8, 10, 12, 15, 20-24, 26-28
Y	US 7914994 B2 (PETERSEN, KE et al.) March 29, 2011; column 25, lines 17-25	8, 24
Y	WO 2012/024543 A1 (SPETZLER, D et al.) February 23, 2012; paragraphs [001069], [001088]; Table 9. This document can be viewed by entering the doc number at the following uri: http://worldwide.espacenet.com/numberSearch?locale=en_EP	10, 26
Y	US 7041206 B2 (GEPHART, CS et al.) May 9, 2006; column 2, lines 33-46	12
Y	US 2009/0130719 A1 (HANDIQUE, K) May 21, 2009; paragraph [0201]	15
Y	US 2010/0203521 A1 (KLAPPERICH, CM et al.) August 12, 2010; paragraph [0068].	20-23
Y	WO 2012/058632 A1 (DEWITTE, R et al.) May 3, 2012; paragraphs [00107], [00188], [0194], [00228], [00248], [00262]	27-28
Y	US 2009/0098541 A1 (SOUTHERN, E et al.) April 16, 2009; paragraph [0169]	7
Y	US 7776583 B2 (BILLADEAU, MA et al.) August 17, 2010; column 21, lines 38-63	7
Y	US 801 7382 B2 (DAVIS, G et al.) September 13, 2011; column 5, lines 26-52; column 8, line 46 to column 9, line 16	22

 Further documents are listed in the continuation of Box C.

* Special categories of cited documents:

"A" document defining the general state of the art which is not considered to be of particular relevance

"E" earlier application or patent but published on or after the international filing date

"L" document which may throw doubts on priority claim(s) or which is cited to establish the publication date of another citation or other special reason (as specified)

"O" document referring to an oral disclosure, use, exhibition or other means

"P" document published prior to the international filing date but later than the priority date claimed

"T" later document published after the international filing date or priority date and not in conflict with the application but cited to understand the principle or theory underlying the invention

"X" document of particular relevance; the claimed invention cannot be considered novel or cannot be considered to involve an inventive step when the document is taken alone

"Y" document of particular relevance; the claimed invention cannot be considered to involve an inventive step when the document is combined with one or more other such documents, such combination being obvious to a person skilled in the art

"&" document member of the same patent family

Date of the actual completion of the international search

30 September 2013 (30.09.2013)

Date of mailing of the international search report

08 OCT 2013

Name and mailing address of the ISA/US

Mail Stop PCT, Attn: ISA/US, Commissioner for Patents
P.O. Box 1450, Alexandria, Virginia 22313-1450

Facsimile No. 571-273-3201

Authorized officer:

Shane Thomas

PCT Helpdesk: 571-272-4300
PCT OSP: 571-272-7774

INTERNATIONAL SEARCH REPORT

International application No.

PCT/US 13/41255

-**- Continued from Box A. CLASSIFICATION OF SUBJECT MATTER -**-

IPC(8): G01N27/327, C12M1/00, G01N33/533, C12Q1/00, G01N21/76, G01N33/566, G01N33/58, G01N33/543, G01N27/30, G01N21/66, G01N27/416, G01N33/536, G01N21/00, C12M1/34, G01N33/53 (2013.01)

USPC: 204/402.01, 406, 407; 264/299; 422/50, 68.1, 81, 82.01, 82.05, 82.08, 129; 435/3, 6.11, 7.1, 29, 91.2, 173.9, 259, 283.1, 286, 287.1, 287.2, 288.5, 289.1; 436/517, 52, 164, 165, 172, 175, 177, 178; 536/25.4

-**- Continued from Box B. FIELDS SEARCHED: Minimum documentation searched (classification system followed by classification symbols) -**-

IPC(8): G01N27/327, C12M1/00, G01N33/533, C12Q1/00, G01N21/76, G01N33/566, G01N33/58, G01N33/543, G01N27/30, G01N21/66, G01N27/416, G01N33/536, G01N21/00, C12M1/34, G01N33/53 (2013.01)

USPC: 204/402.01, 406, 407; 264/299; 422/50, 68.1, 81, 82.01, 82.05, 82.08, 129; 435/3, 6.11, 7.1, 29, 91.2, 173.9, 259, 283.1, 286, 287.1, 287.2, 288.5, 289.1; 436/517, 52, 164, 165, 172, 175, 177, 178; 536/25.4

专利名称(译)	临床诊断系统		
公开(公告)号	EP2852834A1	公开(公告)日	2015-04-01
申请号	EP2013790774	申请日	2013-05-15
申请(专利权)人(译)	WELLSTAT诊断, LLC		
当前申请(专利权)人(译)	定义诊断, LLC		
[标]发明人	COOK RICHARD ALAN CHO SANG DAVIS CHARLES QUENTIN DORSEY KEVIN E HARLEY JASON CHARLES LELAND JONATHAN MATIKYAN ROBER KRIKOR OTTEN SJEF PETERMAN JEFFREY HOWARD THOMAS BRIAN B		
发明人	COOK, RICHARD ALAN CHO, SANG DAVIS, CHARLES QUENTIN DORSEY, KEVIN E. HARLEY, JASON CHARLES LELAND, JONATHAN MATIKYAN, ROBER KRIKOR OTTEN, SJEF PETERMAN, JEFFREY HOWARD THOMAS, BRIAN B.		
IPC分类号	G01N27/327 C12M1/00 G01N33/533 C12Q1/00 G01N21/76 G01N33/566 G01N33/58 G01N33/543 G01N27/30 G01N21/66 G01N27/416 G01N33/536 G01N21/00 C12M1/34 G01N33/53		
CPC分类号	B01L3/527 B01L2200/10 B01L2200/16 B01L2300/042 B01L2300/0861 B01L2300/105 B65B1/04 B65B3 /04 B65B5/04 B65B55/00 F04B49/065 F04B49/106 G01N21/66 G01N27/3273 G01N33/50 G01N33 /536 G01N33/543 G01N33/58 G01N33/582 G01N35/1079 H05B1/025 Y10T436/25 Y10T436/2575		
优先权	PCT/US2012/067041 2012-11-29 WO 13/844450 2013-03-15 US 13/844527 2013-03-15 US 61/647272 2012-05-15 US		
其他公开文献	EP2852834A4		
外部链接	Espacenet		

摘要(译)

本文提供了一种诊断系统,其包括仪器,该仪器包括电化学发光(ECL)检测器,以及配置成装配在仪器的一部分内的盒,其中盒包括至少一种试剂,该试剂包括ECL标签和血液收集保持器。本文还提供了一种系统,其包括诊断仪器,其包括泵,ECL检测器,培养箱,磁体和输出装置,以及配置成装配在诊断仪器的一部分内的盒,样品架配置当药筒装配在诊断仪器的一部分内时,装配在药筒内,以及诊断仪器和药筒之间的闭合流体回路,其中药筒配置成接受来自样品架的样品并将样品置于流体中通过闭合的流体回路与诊断仪器通信。

