

(19)



(11)

**EP 1 573 326 B1**

(12)

**EUROPEAN PATENT SPECIFICATION**

(45) Date of publication and mention of the grant of the patent:  
**17.09.2008 Bulletin 2008/38**

(51) Int Cl.:  
**G01N 33/543 (2006.01) G01N 33/538 (2006.01)**

(21) Application number: **03783087.4**

(86) International application number:  
**PCT/US2003/034543**

(22) Date of filing: **29.10.2003**

(87) International publication number:  
**WO 2004/061454 (22.07.2004 Gazette 2004/30)**

**(54) REDUCTION OF THE HOOK EFFECT IN MEMBRANE-BASED ASSAY DEVICES**

VERRINGERUNG DES HOOK-EFFEKTES IN VORRICHTUNGEN ZUR DURCHFÜHRUNG VON MEMBRAN-BASIERTEN TESTVERFAHREN

REDUCTION DE L'EFFET CROCHET DANS DES DISPOSITIFS D'ESSAIS COMPRENANT UNE MEMBRANE

(84) Designated Contracting States:  
**AT BE BG CH CY CZ DE DK EE ES FI FR GB GR HU IE IT LI LU MC NL PT RO SE SI SK TR**

• **HUANG, Yanbin**  
**Foster City, California 94404 (US)**

(30) Priority: **19.12.2002 US 325614**

(74) Representative: **Grünecker, Kinkeldey, Stockmair & Schwanhäusser**  
**Anwaltssozietät**  
**Leopoldstrasse 4**  
**80802 München (DE)**

(43) Date of publication of application:  
**14.09.2005 Bulletin 2005/37**

(73) Proprietor: **KIMBERLY-CLARK WORLDWIDE, INC.**  
**Neenah, WI 54956 (US)**

(56) References cited:  
**EP-A- 0 073 593 EP-A- 0 617 285**  
**WO-A-00/78917 WO-A-02/077646**  
**US-B1- 6 368 873 US-B1- 6 472 226**

(72) Inventors:  
• **WEI, Ning**  
**Roswell, GA 30075 (US)**

**EP 1 573 326 B1**

Note: Within nine months of the publication of the mention of the grant of the European patent in the European Patent Bulletin, any person may give notice to the European Patent Office of opposition to that patent, in accordance with the Implementing Regulations. Notice of opposition shall not be deemed to have been filed until the opposition fee has been paid. (Art. 99(1) European Patent Convention).

**Description****Background of the Invention**

[0001] Various analytical procedures and devices are commonly employed in flow-through assays to determine the presence and/or concentration of analytes that may be present in a test sample. For instance, immunoassays utilize mechanisms of the immune systems, wherein antibodies are produced in response to the presence of antigens that are pathogenic or foreign to the organisms. These antibodies and antigens, i.e., immunoreactants, are capable of binding with one another, thereby causing a highly specific reaction mechanism that can be used to determine the presence or concentration of that particular antigen in a biological sample.

[0002] There are several well-known immunoassay methods that use immunoreactants labeled with a detectable component so that the analyte can be detected analytically. For example, "sandwich-type" assays typically involve mixing the test sample with detectable probes, such as dyed latex or a radioisotope, which are conjugated with a specific binding member for the analyte. The conjugated probes form complexes with the analyte. These complexes then reach a zone of immobilized antibodies where binding occurs between the antibodies and the analyte to form ternary "sandwich complexes." The sandwich complexes are localized at the zone for detection of the analyte. This technique can be used to obtain quantitative or semi-quantitative results. Some examples of such sandwich-type assays are described in U.S. Patent Nos. 4,168,146 to Grubb, et al. and 4,366,241 to Tom, et al.

[0003] However, many conventional "sandwich-type" assay formats encounter significant inaccuracies when exposed to relatively high analyte concentrations. Specifically, when the analyte is present at high concentrations, a substantial portion of the analyte in the test sample may not form complexes with the conjugated probes. Thus, upon reaching the detection zone, the uncomplexed analyte competes with the complexed analyte for binding sites. Because the uncomplexed analyte is not labeled with a probe, it cannot be detected. Consequently, if a significant number of the binding sites become occupied by the uncomplexed analyte, the assay may exhibit a "false negative." This problem is commonly referred to as the "hook effect."

[0004] Various techniques for reducing the "hook effect" in immunoassays have been proposed. For instance, U.S. Patent No. 6,184,042 to Neumann, et al. describes one technique for reducing the hook effect in a sandwich assay. The technique involves incubating the sample in the presence of a solid phase with at least two receptors capable of binding to the analyte. The first receptor is an oligomer of a binding molecule selected from antibodies, antibody fragments and mixtures thereof. The second receptor is bound to or capable of being bound to a solid phase. The use of a soluble oligomeric

antibody is said to reduce the "hook effect."

[0005] A need still exists, however, for an improved technique of reducing the "hook effect" in a simple, efficient, and relatively inexpensive manner.

**Summary of the Invention**

[0006] In accordance with claim 1, a flow-through assay device for detecting the presence or quantity of an analyte residing in a test sample is disclosed. The flow-through assay device comprises a porous membrane that is in communication with conjugated detection probes capable of generating a detection signal. The porous membrane defines a chromatographic zone within which a plurality of microporous particles are immobilized. The microporous particles can define a plurality of spaces therebetween, the spaces having an average size that is greater than the average size of the micropores. The microporous particles may be selected from the group consisting of polystyrenes, polyacrylamides, polyacrylonitriles; silica beads, and combinations thereof, and the surface thereof may be chemically inert to the analyte.

[0007] In accordance with the present invention, a flow-through, sandwich assay device for detecting the presence or quantity of an analyte residing in a test sample is disclosed. The assay device comprises a porous membrane that is in communication with conjugated detection probes capable of generating a detection signal. The conjugated detection probes are configured to combine with the analyte in the test sample when contacted therewith such that analyte/probe complexes and uncomplexed analyte are formed. The porous membrane defines a chromatographic zone within which a plurality of microporous particles are immobilized. The microporous particles are configured so that the uncomplexed analyte flows through the chromatographic zone at a slower rate than the analyte/probe complexes. The porous membrane further comprises a detection zone located downstream from the chromatographic zone. A capture reagent is immobilized within the detection zone that is configured to bind to the analyte/probe complexes so that the complexes generate a detection signal while within the detection zone, wherein the amount of the analyte within the test sample is determined from the detection signal.

[0008] A method for detecting the presence or quantity of an analyte residing in a test sample is disclosed, in accordance with claim 15.

[0009] Further, particular embodiments of the invention are disclosed, in accordance with the dependent claims.

[0010] The features and aspects of the present invention are discussed in greater detail below.

**Brief Description of the Drawings**

[0011] A full and enabling disclosure of the present in-

vention, including the best mode thereof, directed to one of ordinary skill in the art, is set forth more particularly in the remainder of the specification, which makes reference to the appended figures in which:

Fig. 1 is a perspective view of one embodiment of a flow-through assay device of the present invention; Fig. 2 is a graphical illustration of one embodiment for covalently conjugating an antibody to carboxylated nanoparticles;

Fig. 3 is a schematic illustration of one embodiment of a flow-through assay device of the present invention, shown before the uncomplexed analyte travels through the chromatographic zone;

Fig. 4 is a schematic illustration of the embodiment of Fig. 3, shown after the uncomplexed analyte travels through the chromatographic zone;

Fig. 5 is an exploded view of the chromatographic zone shown in Fig. 1.

**[0012]** Repeat use of reference characters in the present specification and drawings is intended to represent same or analogous features or elements of the invention.

### **Detailed Description of Representative Embodiments**

#### **Definitions**

**[0013]** As used herein, the term "analyte" generally refers to a substance to be detected. For instance, analytes can include antigenic substances, haptens, antibodies, and combinations thereof. Analytes include, but are not limited to, toxins, organic compounds, proteins, peptides, microorganisms, amino acids, nucleic acids, hormones, steroids, vitamins, drugs (including those administered for therapeutic purposes as well as those administered for illicit purposes), drug intermediaries or byproducts, bacteria, virus particles and metabolites of or antibodies to any of the above substances. Specific examples of some analytes include ferritin; creatinine kinase MIB (CK-MB); digoxin; phenytoin; phenobarbital; carbamazepine; vancomycin; gentamycin; theophylline; valproic acid; quinidine; leutinizing hormone (LH); follicle stimulating hormone (FSH); estradiol, progesterone; C-reactive protein; lipocalins; IgE antibodies; vitamin B2 micro-globulin; glycated hemoglobin (Gly. Hb); cortisol; digitoxin; N-acetylprocainamide (NAPA); procainamide; antibodies to rubella, such as rubella-IgG and rubella IgM; antibodies to toxoplasmosis, such as toxoplasmosis IgG (Toxo-IgG) and toxoplasmosis IgM (Toxo-IgM); testosterone; salicylates; acetaminophen; hepatitis B virus surface antigen (HBsAg); antibodies to hepatitis B core antigen, such as anti-hepatitis B core antigen IgG and IgM (Anti-HBC); human immune deficiency virus 1 and 2 (HIV 1 and 2); human T-cell leukemia virus 1 and 2 (HTLV); hepatitis B e antigen (HBeAg); antibodies to hepatitis B

e antigen (Anti-HBe); thyroid stimulating hormone (TSH); thyroxine (T4); total triiodothyronine (Total T3); free triiodothyronine (Free T3); carcinoembryonic antigen (CEA); and alpha fetal protein (AFP). Drugs of abuse and controlled substances include, but are not intended to be limited to, amphetamine; methamphetamine; barbiturates, such as amobarbital, secobarbital, pentobarbital, phenobarbital, and barbital; benzodiazepines, such as librium and valium; cannabinoids, such as hashish and marijuana; cocaine; fentanyl; LSD; methaqualone; opiates, such as heroin, morphine, codeine, hydromorphone, hydrocodone, methadone, oxycodone, oxymorphone and opium; phencyclidine; and propoxyhene. Other potential analytes may be described in U.S. Patent Nos. 6,436,651 to Everhart, et al. and 4,366,241 to Tom et al.

**[0014]** As used herein, the term "test sample" generally refers to a material suspected of containing the analyte. The test sample can be used directly as obtained from the source or following a pretreatment to modify the character of the sample. The test sample can be derived from any biological source, such as a physiological fluid, including, blood, interstitial fluid, saliva, ocular lens fluid, cerebral spinal fluid, sweat, urine, milk, ascites fluid, raucous, synovial fluid, peritoneal fluid, vaginal fluid, amniotic fluid or the like. The test sample can be pretreated prior to use, such as preparing plasma from blood, diluting viscous fluids, and the like. Methods of treatment can involve filtration, precipitation, dilution, distillation, concentration, inactivation of interfering components, and the addition of reagents. Besides physiological fluids, other liquid samples can be used such as water, food products and the like for the performance of environmental or food production assays. In addition, a solid material suspected of containing the analyte can be used as the test sample. In some instances it may be beneficial to modify a solid test sample to form a liquid medium or to release the analyte.

#### **Detailed Description**

**[0015]** Reference now will be made in detail to various embodiments of the invention, one or more examples of which are set forth below. Each example is provided by way of explanation of the invention, not limitation of the invention. For instance, features illustrated or described as part of one embodiment, can be used on another embodiment to yield a still further embodiment. Thus, it is intended that the present invention covers such modifications and variations as come within the scope of the appended claims.

**[0016]** In general, the present invention is directed to a membrane-based assay device for detecting the presence or quantity of an analyte residing in a test sample. The device utilizes a chromatographic zone on which is disposed a plurality of microporous particles. The chromatographic zone can effectively reduce the "hook effect" in a simple, efficient, and relatively inexpensive

manner. In particular, the plurality of microporous particles allows larger-sized analyte/probe complexes to reach the detection zone before the uncomplexed analyte. Because the uncomplexed analyte is substantially inhibited from competing with the complexes for the binding sites at the detection zone, the incidence of "false negatives" may be limited, even at relatively high analyte concentrations.

**[0017]** Referring to Fig. 1, for instance, one embodiment of a flow-through assay device 20 that can be formed according to the present invention will now be described in more detail. As shown, the device 20 contains a porous membrane 23 optionally supported by a rigid material 21. In general, the porous membrane 23 can be made from any of a variety of materials through which the test sample is capable of passing. For example, the materials used to form the porous membrane 23 can include, but are not limited to, natural, synthetic, or naturally occurring materials that are synthetically modified, such as polysaccharides (e.g., cellulose materials such as paper and cellulose derivatives, such as cellulose acetate and nitrocellulose); polyether sulfone; nylon membranes; silica; inorganic materials, such as deactivated alumina, diatomaceous earth,  $MgSO_4$ , or other inorganic finely divided material uniformly dispersed in a porous polymer matrix, with polymers such as vinyl chloride, vinyl chloride-propylene copolymer, and vinyl chloride-vinyl acetate copolymer; cloth, both naturally occurring (e.g., cotton) and synthetic (e.g., nylon or rayon); porous gels, such as silica gel, agarose, dextran, and gelatin; polymeric films, such as polyacrylamide; and the like. In one particular embodiment, the porous membrane 23 is formed from nitrocellulose and/or polyester sulfone materials. It should be understood that the term "nitrocellulose" refers to nitric acid esters of cellulose, which may be nitrocellulose alone, or a mixed ester of nitric acid and other acids, such as aliphatic carboxylic acids having from 1 to 7 carbon atoms.

**[0018]** The device 20 may also contain a wicking pad 28. The wicking pad 28 generally receives fluid that has migrated through the entire porous membrane 23. As is well known in the art, the wicking pad 28 can assist in promoting capillary action and fluid flow through the membrane 23.

**[0019]** To initiate the detection of an analyte within the test sample, a user may directly apply the test sample to a portion of the porous membrane 23 through which it can then travel. Alternatively, the test sample may first be applied to a sampling pad (not shown) that is in fluid communication with the porous membrane 23. Some suitable materials that can be used to form the sampling pad include, but are not limited to, nitrocellulose, cellulose, porous polyethylene pads, and glass fiber filter paper. If desired, the sampling pad may also contain one or more assay pretreatment reagents, either diffusively or non-diffusively attached thereto.

**[0020]** In the illustrated embodiment, the test sample travels from the sampling pad (not shown) to a conjugate

pad 22 that is placed in communication with one end of the sampling pad. The conjugate pad 22 is formed from a material through which the test sample is capable of passing. For example, in one embodiment, the conjugate pad 22 is formed from glass fibers. Although only one conjugate pad 22 is shown, it should be understood that other conjugate pads may also be used in the present invention.

**[0021]** To facilitate accurate detection of the presence or absence of an analyte within the test sample, probes are applied at various locations of the device 20. As described in more detail below, probes may be used for both detection of the analyte and for calibration. Any substance generally capable of generating a signal that is detectable visually or by an instrumental device may be used as probes. Various suitable substances can include chromogens; catalysts; fluorescent compounds; chemiluminescent compounds; phosphorescent compounds; radioactive compounds; direct visual labels, including colloidal metallic (e.g., gold) and non-metallic particles, dye particles, enzymes or substrates, or organic polymer latex particles; liposomes or other vesicles containing signal producing substances; and the like. For instance, some enzymes suitable for use as probes are disclosed in U.S. Patent No. 4,275,149 to Litman, et al., One example of an enzyme/substrate system is the enzyme alkaline phosphatase and the substrate nitro blue tetrazolium-5-bromo-4-chloro-3-indolyl phosphate, or derivative or analog thereof, or the substrate 4-methylumbelliferyl-phosphate. Other suitable probes may be described in U.S. Patent Nos. 5,670,381 to Jou, et al., and 5,252,459 to Tarcha, et al.

**[0022]** In some embodiments, the probes can contain a fluorescent compound that produces a detectable signal. The fluorescent compounds can be fluorescent molecules, polymers, dendrimers, particles, and the like. Some examples of suitable fluorescent molecules, for instance, include, but are not limited to, fluorescein, europium chelates, phycobiliprotein, rhodamine and their derivatives and analogs. A visually detectable, colored compound can also be used as a probe, thereby providing for a direct colored readout of the presence or concentration of the analyte in the sample without the need for further signal producing reagents.

**[0023]** The probes, such as described above, may be used alone or in conjunction with a microparticle (sometimes referred to as "beads" or "microbeads"). For instance, naturally occurring microparticles, such as nuclei, mycoplasma, plasmids, plastids, mammalian cells (e.g., erythrocyte ghosts), unicellular microorganisms (e.g., bacteria), polysaccharides (e.g., agarose), and the like, can be used. Further, synthetic microparticles may also be utilized. For example, in one embodiment, latex microparticles that are labeled with a fluorescent or colored dye are utilized. Although any latex microparticle may be used in the present invention, the latex microparticles are typically formed from polystyrene, butadiene styrenes, styreneacrylic-vinyl terpolymer, polymethylmeth-

acrylate, polyethylmethacrylate, styrene-maleic anhydride copolymer, polyvinyl acetate, polyvinylpyridine, polydivinylbenzene, polybutyleneterephthalate, acrylonitrile, vinylchloride-acrylates, and the like, or an aldehyde, carboxyl, amino, hydroxyl, or hydrazide derivative thereof. Other suitable microparticles may be described in U.S. Patent Nos. 5,670,381 to Jou, et al. and 5,252,459 to Tarcha, et al., Some commercially available examples of suitable fluorescent particles include fluorescent carboxylated microspheres sold by Molecular Probes, Inc. under the trade names "FluoSphere" (Red 580/605) and "TransfluoSphere" (543/620), as well as "Texas Red" and 5- and 6-carboxytetramethylrhodamine, which are also sold by Molecular Probes, Inc. Commercially available examples of suitable colored, latex microparticles include carboxylated latex beads sold by Bang's Laboratory, Inc.

**[0024]** The probes are modified with certain specific binding members that are adhered thereto to form conjugated probes. Specific binding members generally refer to a member of a specific binding pair, i.e., two different molecules where one of the molecules chemically and/or physically binds to the second molecule. For instance, immunoreactive specific binding members can include antigens, haptens, aptamers, antibodies, and complexes thereof, including those formed by recombinant DNA methods or peptide synthesis. An antibody can be a monoclonal or polyclonal antibody, a recombinant protein or a mixture(s) or fragment(s) thereof, as well as a mixture of an antibody and other specific binding members. The details of the preparation of such antibodies and their suitability for use as specific binding members are well known to those skilled in the art. Other common specific binding pairs include but are not limited to, biotin and avidin, carbohydrates and lectins, complementary nucleotide sequences (including probe and capture nucleic acid sequences used in DNA hybridization assays to detect a target nucleic acid sequence); complementary peptide sequences including those formed by recombinant methods, effector and receptor molecules, hormone and hormone binding protein, enzyme cofactors and enzymes, enzyme inhibitors and enzymes, and the like. Furthermore, specific binding pairs can include members that are analogs of the original specific binding member. For example, a derivative or fragment of the analyte, i.e., an analyte-analog, can be used so long as it has at least one epitope in common with the analyte.

**[0025]** The specific binding members can generally be attached to the probes using any of a variety of well-known techniques. For instance, covalent attachment of the specific binding members to the probes (e.g., microparticles) can be accomplished using carboxylic, amino, aldehyde, bromoacetyl, iodoacetyl, thiol, epoxy and other reactive or linking functional groups, as well as residual free radicals and radical cations, through which a protein coupling reaction can be accomplished. A surface functional group can also be incorporated as a functionalized co-monomer because the surface of the microparticle can contain a relatively high surface concentration of po-

lar groups. In addition, although microparticle probes are often functionalized after synthesis, in certain cases, such as poly(thiophenol), the microparticles are capable of direct covalent linking with a protein without the need for further modification. For example, referring to Fig. 2, one embodiment of the present invention for covalently conjugating a probe is illustrated. As shown, the first step of conjugation is activation of carboxylic groups on the probe surface using carbodiimide. In the second step, the activated carboxylic acid groups are reacted with an amino group of an antibody to form an amide bond. The activation and/or antibody coupling can occur in a buffer, such as phosphate-buffered saline (PBS) (e.g., pH of 7.2) or 2-(N-morpholino) ethane sulfonic acid (MES) (e.g., pH of 5.3). As shown, the resulting probes can then be blocked with ethanolamine, for instance, to form the probe conjugate. Besides covalent bonding, other attachment techniques, such as physical adsorption, may also be utilized in the present invention.

**[0026]** As indicated above, some of the analyte in the test sample may not become complexed to the conjugated probes in the desired manner, particularly when the analyte is present in the test sample at high concentrations. This uncomplexed analyte can later compete with the complexed analyte for the capture reagent at the detection zone 31 (described below), thereby adversely affecting the accuracy of the assay device 20. To counteract this affect, the porous membrane 23 contains a chromatographic zone 35 on which a plurality of microporous particles 50 are distributed. As shown in Figs. 3-5, the presence of microporous particles 50 allows the chromatographic zone 35 to act as a "gel permeation" column in that larger molecules move through the chromatographic zone 35 at a faster rate than smaller molecules. Specifically, as shown in Fig. 5, molecules larger in size than the micropores 51 of the microporous particles 50 cannot flow therethrough and thus are forced to flow through the spaces 52 between the particles 50, i.e., through the pores of the membrane 23 (illustrated as directional arrow  $L_2$ ). Because the micropores 51 of the particles 50 form "tortuous paths" (i.e., paths having complex shapes) within the particulate structure, it generally takes a longer period of time for a molecule to travel through the micropores 51 than through the spaces 52 between the particles 50. Accordingly, when traveling through the chromatographic zone 35, larger-sized molecules exit first. Intermediate-sized molecules penetrate the microporous particles 50 to varying extents depending on their size. Finally, very small molecules flow through the micropores 51 of the particles 50 (illustrated by directional arrow  $L_1$ ) and thus exit the chromatographic zone 35 last. Generally speaking, analyte/probe complexes are larger in size than uncomplexed analytes. Accordingly, the complexes can reach the detection zone 31 and bind to a capture reagent contained thereon before the uncomplexed analyte reaches the detection zone 31. In this manner, competition between the complexed and uncomplexed analyte is inhibited.

**[0027]** The chromatographic zone 35 generally provides a single distinct region (e.g., line, dot, etc.), although multiple regions are certainly contemplated by the present invention. For instance, in the illustrated embodiment, a single line is utilized. When utilized, the width of the line may generally vary. For example, in some embodiments, the width of the line in the direction L of analyte flow is from about 10% to about 100%, and in some embodiments, from about 10% to about 50% of the total distance measured from the location at which the analyte is applied (e.g., the conjugate pad 22) to the detection zone 31. Further, the line may be disposed in a direction that is substantially perpendicular to the flow of the test sample through the device 20. Likewise, in some embodiments, the line may be disposed in a direction that is substantially parallel to the flow of the test sample through the device 20.

**[0028]** The criteria for selecting appropriate microporous particles 50 for use in a given assay can include a variety of factors, such as the nature of the analyte of interest, the conditions of testing, the nature of the probes utilized, etc. Typically, it is desired that the microporous particles 50 have a relative uniform pore and particle size distribution and good mechanical and chemical stability. In addition, it is also typically desired that the surface of the microporous particles 50 remains chemically inert to other components of the assay device 20. For instance, the surface of the microporous particles 50 is generally chemically inert with respect to the analyte. Some examples of microporous particles 50 that may be used in the present invention include, but are not limited to, synthetic polymeric particles, such as polystyrenes (e.g., highly crosslinked polystyrene), polyacrylamides, polyacrylonitriles; silica beads, etc. Specific examples of some suitable synthetic microporous particles 50 are described, for instance, in U.S. Patent No. 4,110,529 to Stoy; 4,940,734 to Ley, et al.; and 5,314,923 to Cooke, et al. In embodiments in which the probes are also microporous particles, it should be understood that the microporous particles 50 of the chromatographic zone 35 may be the same as the probes.

**[0029]** The average diameter of the microporous particles 50 may generally vary as desired. For example, in some embodiments, the average diameter of the particles 50 can range from about 0.1 to about 1,000  $\mu\text{m}$  (microns), in some embodiments from about 0.1 to about 100  $\mu\text{m}$  (microns), and in some embodiments, from about 1 to about 10  $\mu\text{m}$  (microns). Typically, the particles 50 are substantially spherical in shape (i.e., beads), although other shapes including, but not limited to, plates, rods, bars, irregular shapes, etc., are suitable for use in the present invention. As will be appreciated by those skilled in the art, the composition, shape, size, and/or density of the particles 50 may widely vary.

**[0030]** Generally speaking, the micropores 51 of the particles 50 have an average size (i.e., diameter) that is smaller than the spaces between the particles 50 formed by the pores 52 of the porous membrane 23. Specifically,

the average size of the micropores 51 is typically at least about 100%, in some embodiments, at least about 150%, and in some embodiments, at least about 250% smaller than the average size of the spaces therebetween. In some embodiments, for instance, the micropores 51 have an average size less than about 100 nanometers, in some embodiments from about 5 to about 100 nanometers, and in some embodiments, from about 10 to about 60 nanometers. As a comparison, the pores 52 of the porous membrane 23 typically have an average size of greater than about 200 nanometers, in some embodiments from about 200 to about 5000 nanometers, and in some embodiments, from about 200 to about 2500 nanometers.

**[0031]** The assay device 20 may also contain a detection zone 31, on which is immobilized a capture reagent that is capable of binding to the conjugated probes. For example, in some embodiments, the capture reagent may be a biological capture reagent. Such biological capture reagents are well known in the art and can include, but are not limited to, antigens, haptens, antibodies, protein A or G, avidin, streptavidin, secondary antibodies, and complexes thereof. In many cases, it is desired that these biological capture reagents are capable of binding to a specific binding member (e.g., antibody) present on the probes. In addition, it may also be desired to utilize various non-biological materials for the capture reagent. For instance, in some embodiments, the capture reagent can include a polyelectrolyte. The polyelectrolytes can have a net positive or negative charge, as well as a net charge that is generally neutral. For instance, some suitable examples of polyelectrolytes having a net positive charge include, but are not limited to, polylysine (commercially available from Sigma-Aldrich Chemical Co., Inc. of St. Louis, MO), polyethylenimine; epichlorohydrin-functionalized polyamines and/or polyamidoamines, such as poly(dimethylamine-co-epichlorohydrin); polydiallyldimethyl-ammonium chloride; cationic cellulose derivatives, such as cellulose copolymers or cellulose derivatives grafted with a quaternary ammonium water-soluble monomer; and the like. In one particular embodiment, CelQuat® SC-230M or H-100 (available from National Starch & Chemical, Inc.), which are cellulosic derivatives containing a quaternary ammonium water-soluble monomer, can be utilized. Moreover, some suitable examples of polyelectrolytes having a net negative charge include, but are not limited to, polyacrylic acids, such as poly(ethylene-co-methacrylic acid, sodium salt), and the like. It should also be understood that other polyelectrolytes may also be utilized, such as amphiphilic polyelectrolytes (i.e., having polar and non-polar portions). For instance, some examples of suitable amphiphilic polyelectrolytes include, but are not limited to, poly(styryl-b-N-methyl 2-vinyl pyridinium iodide) and poly(styryl-b-acrylic acid), both of which are available from Polymer Source, Inc. of Dorval, Canada.

**[0032]** The capture reagent serves as a stationary binding site for the analyte/probe complexes. Specific-

ly, analytes, such as antibodies, antigens, etc., typically have two binding sites. Upon reaching the detection zone 31, one of these binding sites is occupied by the specific binding member of the conjugated probe. However, the free binding site of the analyte can bind to the immobilized capture reagent. Upon being bound to the immobilized capture reagent, the complexed probes form a new ternary sandwich complex.

**[0033]** The detection zone 31 may generally provide any number of distinct detection regions so that a user can better determine the concentration of a particular analyte within a test sample. Each region may contain the same capture reagents, or may contain different capture reagents for capturing multiple analytes. For example, the detection zone 31 may include two or more distinct detection regions (e.g., lines, dots, etc.). The detection regions may be disposed in the form of lines in a direction that is substantially perpendicular to the flow of the test sample through the assay device 20. Likewise, in some embodiments, the detection regions can be disposed in the form of lines in a direction that is substantially parallel to the flow of the test sample through the assay device.

**[0034]** Although the detection zone 31 may indicate the presence of an analyte, it is often difficult to determine the relative concentration of the analyte within the test sample using solely a detection zone 31. Thus, the assay device 20 may also include a calibration zone 32. In this embodiment, the calibration zone 32 is formed on the porous membrane 23 and is positioned downstream from the detection zone 31. The calibration zone 32 is provided with a capture reagent that is capable of binding to any remaining uncaptured probes that pass through the length of the membrane 23. The capture reagent utilized in the calibration zone 32 may be the same or different than the capture reagent used in the detection zone 31. Moreover, similar to the detection zone 31, the calibration zone 32 may also provide any number of distinct calibration regions in any direction so that a user can better determine the concentration of a particular analyte within a test sample. Each region may contain the same capture reagents, or may contain different capture reagents for capturing different probes.

**[0035]** The calibration regions may be pre-loaded on the porous membrane 23 with different amounts of the capture reagent so that a different signal intensity is generated by each calibration region upon migration of the probes. The overall amount of binder within each calibration region can be varied by utilizing calibration regions of different sizes and/or by varying the concentration or volume of the capture reagent in each calibration region. If desired, an excess of probes can be employed in the assay device 20 so that each calibration region reaches its full and predetermined potential for signal intensity. That is, the amount of probes that are deposited upon calibration regions are predetermined because the amount of the capture reagent employed on the calibration regions is set at a predetermined and known level.

**[0036]** In general, a variety of flow-through assay de-

vices may be constructed according to the present invention. In this regard, various embodiments of the present invention will now be described in more detail. It should be understood, however, that the embodiments discussed below are only exemplary, and that other embodiments are also contemplated by the present invention. For instance, referring to Figs. 3-4, one particular embodiment in which probes 41 are used for detection and probes 43 are used for calibration is shown. In this embodiment, the detection probes 41 and calibration probes 43 are applied to the conjugate pad 22 and are thus capable of flowing through the device 20 (as indicated by the directional arrow L) when placed in communication with the test sample. The detection probes 41 are conjugated with a specific binding member 90 for an analyte A so that, upon contact with the analyte A, the probes 41 bind thereto to form analyte/probe complexes 49.

**[0037]** As shown in Fig. 3, the probe/analyte complexes 49, any free analyte A, and the calibration probes 43 flow from the conjugate pad 22 through the porous membrane 23 until they reach the chromatographic zone 35 on which is disposed a plurality of microporous particles 50. The larger complexes 49 and calibration probes 43 readily flow through the spaces 52 between the particles 50, while the smaller uncomplexed analyte A flows within the micropores of the particles 50 at a slower rate. The analyte/probe complexes 49 then flow through the device 20 until they reach the detection zone 31 where they bind to a capture reagent 91, such as an antibody, to form sandwich complexes 53. Further, the calibration probes 43 flow to the calibration zone 32 and bind to a capture reagent (not shown), such as polyelectrolyte. Thereafter, as shown in Fig. 4, the uncomplexed analyte A travels through the chromatographic zone 35 to reach the detection zone 31. Because the complexes 49 are already bound to the capture reagent, however, the analyte A moves through the detection zone 31 and calibration zone 32 until it reaches the wicking pad 28. Thus, at the detection zone 31, the amount of the analyte can be ascertained from the signal intensity of the detection probes 41. If desired, this signal intensity may be calibrated by the signal intensity of the calibration probes 43 at the calibration zone 32. The signal intensities may be measured visually or through the aid of a device, such as a fluorescence reader.

**[0038]** Although various embodiments of device configurations have been described above, it should be understood, that a device of the present invention may generally have any configuration in accordance with claim 1 desired, and need not contain all of the components described above. Various other device configurations and/or assay formats, for instance, are described in U.S. Patent Nos. 5,395,754 to Lambotte, et al.; 5,670,381 to Jou, et al.; and 6,194,220 to Malick, et al.,

**[0039]** The present inventors have discovered that the presence of a chromatographic zone on the porous membrane of an assay device can effectively reduce the "hook

effect" In a simple, efficient, and relatively inexpensive manner. In particular, a plurality of microporous particles can be disposed on the chromatographic zone to allow larger-sized analyte/probes complexes to reach the detection before any uncomplexed analyte. Accordingly, the uncomplexed analyte does not compete with the complexes for available binding sites at the detection zone. Because the uncomplexed analyte is inhibited from occupying a substantial number of the binding sites at the detection zone, the incidence of "false negatives" may be limited, even at relatively high analyte concentrations.

**[0040]** While the invention has been described in detail with respect to the specific embodiments thereof, it will be appreciated that those skilled in the art, upon attaining an understanding of the forgoing, may readily conceive of alterations to, variations of, and equivalents to these embodiments. Accordingly, the scope of the present invention should be assessed as that of the appended claims.

### Claims

1. A flow-through assay device for detecting the presence or quantity of an analyte residing in a test sample, said assay device comprising a porous membrane, said porous membrane being in communication with conjugated detection probes capable of generating a detection signal, said conjugated detection probes being configured to combine with the analyte in the test sample when contacted therewith such that analyte/probe complexes and uncomplexed analyte are formed, wherein specific binding members are adhered to the probes to form the conjugated probes, said porous membrane defining:
  - a chromatographic zone within which a plurality of microporous particles are immobilized, said microporous particles being configured so that said uncomplexed analyte flows through said chromatographic zone at a slower rate than said analyte/probe complexes; and
  - a detection zone located downstream from said chromatographic zone, wherein a capture reagent is immobilized within said detection zone that is configured to bind to said analyte/probe complexes so that said complexes generate a detection signal while within said detection zone, wherein the amount of the analyte within the test sample is determined from said detection signal.
2. A flow-through assay device as defined in claim 1, wherein said microporous particles define a plurality of spaces therebetween, said spaces having an average size that is greater than the average size of the micropores of said particles.
3. A flow-through assay device as defined in claim 1, wherein the average diameter of said micropores is less than about 100 nanometers.
4. A flow-through assay device as defined in claim 1, wherein the average diameter of said micropores is from about 10 to about 60 nanometers.
5. A flow-through assay device as defined in claim 1, wherein said microporous particles are selected from the group consisting of polystyrenes, polyacrylamides, polyacrylonitriles, silica beads, and combinations thereof.
6. A flow-through assay device as defined in claim 1, wherein the surface of said microporous particles is chemically inert to the analyte.
7. A flow-through assay device as defined in claim 1, wherein said conjugated detection probes comprise a substance selected from the group consisting of chromogens, catalysts, fluorescent compounds, chemiluminescent compounds, phosphorescent compounds, radioactive compounds, direct visual labels, liposomes, and combinations thereof.
8. A flow-through assay device as defined in claim 1, wherein said porous membrane further comprises a calibration zone capable of generating a calibration signal, wherein the amount of the analyte within the test sample is determined from said detection signal as calibrated by said calibration signal.
9. A flow-through assay device as defined in claim 8, wherein said porous membrane is in communication with calibration probes, said calibration probes generating said calibration signal when present within said calibration zone.
10. A flow-through assay device as defined in claim 1, wherein the device is a sandwich-type assay device.
11. A flow-through assay device as defined in any of claims 1 - 10, wherein said microporous particles have an average diameter of from about 0.1 to about 100 micrometers.
12. A flow-through assay device as defined in any of claims 1 - 10, wherein said microporous particles have an average diameter of from about 1 to about 10 micrometers.
13. A flow-through assay device as defined in any of claims 1 - 10, wherein said specific binding members are antibodies.
14. A flow-through assay device as defined in any of claims 1 - 10, wherein said capture reagent is an

antibody.

15. A method for detecting the presence or quantity of an analyte residing in a test sample, said method comprising:

i) providing a flow-through assay device comprising a porous membrane, said porous membrane being in communication with conjugated detection probes capable of generating a detection signal, wherein specific binding members are adhered to the probes to form the conjugated probes, said porous membrane defining a chromatographic zone within which a plurality of microporous particles are immobilized and a detection zone located downstream from said chromatographic zone, wherein a capture reagent is immobilized within said detection zone; ii) contacting a test sample containing the analyte with said conjugated detection probes so that analyte/probe complexes and uncomplexed analyte are formed; and iii) allowing said analyte/probe complexes and said uncomplexed analyte to reach said chromatographic zone and then said detection zone, wherein said analyte/probe complexes reach said detection zone before said uncomplexed analyte.

16. A method as defined in claim 15, wherein said microporous particles define a plurality of spaces therebetween, said spaces having an average size that is greater than the average size of the micropores of said particles.

17. A method as defined in claim 15, wherein said microporous particles are selected from the group consisting of polystyrenes, polyacrylamides, polyacrylonitriles, silica beads, and combinations thereof.

18. A method as defined in claim 15, wherein the surface of said microporous particles is chemically inert to the analyte.

19. A method as defined in claim 15, further comprising measuring the intensity of the detection signal generated within said detection zone.

20. A method as defined in claim 15, wherein said porous membrane further comprises a calibration zone capable of generating a calibration signal, wherein the amount of the analyte within the test sample is determined from said detection signal as calibrated by said calibration signal.

21. A method as defined in claim 20, wherein said porous membrane is in communication with calibration probes, said calibration probes generating said cal-

ibration signal when present within said calibration zone.

22. A method as defined in claim 21, further comprising generating a calibration curve by plotting the intensity of the detection signal calibrated by the intensity of the calibration signal for a plurality of predetermined analyte concentrations.

## Patentansprüche

1. Eine Durchströmungsuntersuchungsvorrichtung zum Detektieren der Gegenwart oder Menge eines Analyts, das sich in einer Testprobe befindet, wobei die genannte Durchströmungsuntersuchungsvorrichtung eine poröse Membran umfasst, wobei die genannte poröse Membran in Verbindung mit konjugierten Detektionssonden steht, die in der Lage sind, ein Detektionssignal zu erzeugen, wobei die genannten konjugierten Detektionssonden dazu ausgebildet sind, sich mit dem Analyt in der Testprobe zu verbinden, wenn sie damit in Kontakt geraten, so dass Analyt-/Sondenkomplexe und ein komplexfreies Analyt gebildet werden, wobei spezifische Bindungselemente an den Sonden anhaften, um die konjugierten Sonden zu bilden, wobei die poröse Membran bildet:

eine chromatographische Zone, in der eine Mehrzahl an mikroporösen Teilchen immobilisiert ist, wobei die mikroporösen Teilchen so ausgebildet sind, dass das genannte komplexfreie Analyt mit einer geringeren Rate als die genannten Analyt-/Sondenkomplexe durch die genannte chromatographische Zone strömen; und eine Detektionszone, die sich stromabwärts von der genannten chromatographischen Zone befindet, wobei ein Einfangreagens in der genannten Detektionszone immobilisiert ist, das dazu ausgebildet ist, sich an die genannten Analyt-/Sondenkomplexe zu binden, so dass die genannten Komplexe ein Detektionssignal erzeugen, während sie sich in der Detektionszone befinden, wobei die Menge des Analyts in der genannten Testprobe aus dem genannten Detektionssignal bestimmt wird.

2. Eine Durchströmungsuntersuchungsvorrichtung, wie sie in Anspruch 1 definiert ist, in der die genannten mikroporösen Teilchen eine Mehrzahl an Räumen zwischen sich bilden, wobei die Räume eine mittlere Größe aufweisen, die größer als die mittlere Größe der Mikroporen der genannten Teilchen ist.
3. Eine Durchströmungsuntersuchungsvorrichtung, wie sie in Anspruch 1 definiert ist, in der der mittlere

- Durchmesser der genannten Mikroporen geringer als etwa 100 Nanometer ist.
4. Eine Durchströmungsuntersuchungsvorrichtung, wie sie in Anspruch 1 definiert ist, in der der mittlere Durchmesser der genannten Mikroporen zwischen etwa 10 und etwa 60 Nanometern liegt. 5
5. Eine Durchströmungsuntersuchungsvorrichtung, wie sie in Anspruch 1 definiert ist, in der die genannten mikroporösen Teilchen aus der Gruppe ausgewählt sind, die aus Polystyrenen, Polyacrylamiden, Polyacrylnitrilen, Silica-Ketten und Kombinationen davon besteht. 10
6. Eine Durchströmungsuntersuchungsvorrichtung, wie sie in Anspruch 1 definiert ist, in der die Oberfläche der genannten mikroporösen Teilchen gegenüber dem Analyt chemisch inaktiv ist. 15
7. Eine Durchströmungsuntersuchungsvorrichtung, wie sie in Anspruch 1 definiert ist, in der die genannten konjugierten Detektionssonden eine Substanz umfassen, die aus der Gruppe ausgewählt ist, die aus Chromogenen, Katalysatoren, fluoreszenten Verbindungen, chemilumineszenten Verbindungen, phosphoreszenten Verbindungen, radioaktiven Verbindungen, direkt sichtbaren Markern, Liposomen und Kombinationen davon besteht. 20 25
8. Eine Durchströmungsuntersuchungsvorrichtung, wie sie in Anspruch 1 definiert ist, in der die genannte poröse Membran weiterhin eine Kalibrationszone umfasst, die in der Lage ist, ein Kalibrationssignal zu erzeugen, wobei die Menge des Analyts in der Testprobe aus dem genannten Detektionssignal, wie es durch das genannte Kalibrationssignal kalibriert ist, bestimmt wird. 30 35
9. Eine Durchströmungsuntersuchungsvorrichtung, wie sie in Anspruch 8 definiert ist, in der die genannte poröse Membran in Verbindung mit Kalibrationssonden steht, wobei die genannten Kalibrationssonden das genannte Kalibrationssignal erzeugen, wenn sie sich in der genannten Kalibrationszone befinden. 40 45
10. Eine Durchströmungsuntersuchungsvorrichtung, wie sie in Anspruch 1 definiert ist, in der die Vorrichtung eine Untersuchungsvorrichtung der Sandwich-Art ist. 50
11. Eine Durchströmungsuntersuchungsvorrichtung, wie sie in einem der Ansprüche 1 - 10 definiert ist, in der die genannten mikroporösen Teilchen einen mittleren Durchmesser von etwa 0,1 bis etwa 100 Mikrometern besitzen. 55
12. Eine Durchströmungsuntersuchungsvorrichtung, wie sie in einem der Ansprüche 1 - 10 definiert ist, in der die genannten mikroporösen Teilchen einen mittleren Durchmesser von etwa 1 bis etwa 10 Mikrometern besitzen.
13. Eine Durchströmungsuntersuchungsvorrichtung, wie sie in einem der Ansprüche 1 - 10 definiert ist, in der die genannten spezifischen Bindeelemente Antikörper sind.
14. Eine Durchströmungsuntersuchungsvorrichtung, wie sie in einem der Ansprüche 1 - 10 definiert ist, in der das genannte Einfangreagens ein Antikörper ist.
15. Ein Verfahren zum Detektieren der Gegenwart oder Menge eines Analyts, das sich in einer Testprobe befindet, wobei das genannte Verfahren umfasst:
- i) Bereitstellen einer Durchströmungsuntersuchungsvorrichtung, die eine poröse Membran umfasst, wobei die genannte poröse Membran in Verbindung mit konjugierten Detektionssonden steht, die in der Lage sind, ein Detektionssignal zu erzeugen, wobei spezifische Bindeelemente an den Sonden haften, um die konjugierten Sonden zu bilden, wobei die genannte poröse Membran eine chromatographische Zone, in der eine Mehrzahl an mikroporösen Teilchen immobilisiert ist, und eine Detektionszone, die sich stromabwärts von der genannten chromatographischen Zone befindet, wobei ein Einfangreagens in der genannten Detektionszone immobilisiert ist, ausbildet;
- ii) Kontaktieren einer Testprobe, die das Analyt enthält, mit den genannten konjugierten Sonden, so dass Analyt-/Sondenkomplexe und ein komplexfreies Analyt gebildet werden; und
- iii) es den genannten Analyt-/Sondenkomplexen und dem genannten komplexfreien Analyt zu ermöglichen, die genannte chromatographische Zone und sodann die genannte Detektionszone zu erreichen, wobei die genannten Analyt-/Sondenkomplexe die genannte Detektionszone vor dem genannten komplexfreien Analyt erreichen.
16. Ein Verfahren, wie es in Anspruch 15 definiert ist, in dem die genannten mikroporösen Teilchen eine Mehrzahl an Räumen zwischen sich bilden, wobei die Räume eine mittlere Größe aufweisen, die größer als die mittlere Größe der Mikroporen der genannten Teilchen ist.
17. Ein Verfahren, wie es in Anspruch 15 definiert ist, in dem die genannten mikroporösen Teilchen aus der Gruppe ausgewählt sind, die aus Polystyrenen, Polyacrylamiden, Polyacrylnitrilen, Silica-Ketten und

Kombinationen davon besteht.

18. Ein Verfahren, wie es in Anspruch 15 definiert ist, in dem die Oberfläche der genannten mikroporösen Teilchen gegenüber dem Analyt chemisch inaktiv ist. 5
19. Ein Verfahren, wie es in Anspruch 15 definiert ist, das weiterhin das Messen der Intensität des Detektionssignals, das in der genannten Detektionszone erzeugt wird, umfasst. 10
20. Ein Verfahren, wie es in Anspruch 15 definiert ist, in dem die genannte poröse Membran weiterhin eine Kalibrationszone umfasst, die in der Lage ist, ein Kalibrationssignal zu erzeugen, wobei die Menge des Analyts in der Testprobe aus dem genannten Detektionssignal, wie es durch das genannte Kalibrationssignal kalibriert ist, bestimmt wird. 15
21. Ein Verfahren, wie es in Anspruch 20 definiert ist, in dem die genannte poröse Membran in Verbindung mit Kalibrationssonden steht, wobei die genannten Kalibrationssonden das genannte Kalibrationssignal erzeugen, wenn sie sich in der genannten Kalibrationszone befinden. 20
22. Ein Verfahren, wie es in Anspruch 20 definiert ist, das weiterhin das Erzeugen einer Kalibrationskurve durch Auftragen der Intensität des Detektionssignals kalibriert durch die Intensität des Kalibrationssignals für eine Mehrzahl an vorbestimmten Analytkonzentrationen umfasst. 25

### Revendications 35

1. Dispositif d'analyse à renouvellement continu pour détecter la présence ou quantité d'un analyte se trouvant dans un échantillon à tester, ledit dispositif d'analyse comprenant une membrane poreuse, ladite membrane poreuse étant en communication avec des sondes de détection conjuguées capables de produire un signal de détection, lesdites sondes de détection conjuguées étant configurées pour se combiner avec l'analyte dans l'échantillon à tester lorsque venant au contact de celui-ci de sorte que des complexes analyte/sonde et un analyte non complexé sont formés, des éléments de liaison spécifiques adhérant aux sondes pour former les sondes conjuguées, ladite membrane poreuse définissant : 40
- une zone chromatographique au sein de laquelle une pluralité de particules microporeuses sont immobilisées, lesdites particules microporeuses étant configurées de sorte que ledit analyte non complexé circule au travers de ladite zone chromatographique à une vitesse inférieure à celle desdits complexes analyte/sonde ; et 45

une zone de détection située en aval de ladite zone chromatographique, un réactif de capture étant immobilisé au sein de ladite zone de détection, étant configuré pour se lier auxdits complexes analyte/sonde de sorte que lesdits complexes produisent un signal de détection tandis qu'ils sont au sein de la zone de détection, la quantité d'analyte au sein de l'échantillon à tester étant déterminée à partir dudit signal de détection.

2. Dispositif d'analyse à renouvellement continu selon la revendication 1, dans lequel lesdites particules microporeuses définissent une pluralité d'espaces entre elles, lesdits espaces ayant une dimension moyenne qui est supérieure à la dimension moyenne des micropores desdites particules.
3. Dispositif d'analyse à renouvellement continu selon la revendication 1, dans lequel le diamètre moyen desdits micropores est inférieur à environ 100 nanomètres.
4. Dispositif d'analyse à renouvellement continu selon la revendication 1, dans lequel le diamètre moyen desdits micropores est compris entre environ 10 et environ 60 nanomètres.
5. Dispositif d'analyse à renouvellement continu selon la revendication 1, dans lequel lesdites particules microporeuses sont sélectionnées dans le groupe consistant en les polystyrènes, les polyacrylamides, les polyacrylonitriles, les billes de silice, et leurs combinaisons.
6. Dispositif d'analyse à renouvellement continu selon la revendication 1, dans lequel la surface desdites particules microporeuses est inerte chimiquement vis-à-vis de l'analyte.
7. Dispositif d'analyse à renouvellement continu selon la revendication 1, dans lequel lesdites sondes de détection conjuguées comprennent une substance sélectionnée dans le groupe consistant en les chromogènes, les catalyseurs, les composés fluorescents, les composés chimioluminescents, les composés phosphorescents, les composés radioactifs, les marquages à accès visuel direct, les liposomes, et leurs combinaisons.
8. Dispositif d'analyse à renouvellement continu selon la revendication 1, dans lequel ladite membrane poreuse comprend en outre une zone d'étalonnage capable de produire un signal d'étalonnage, la quantité de l'analyte au sein de l'échantillon à tester étant déterminée à partir dudit signal de détection tel qu'étalonné par ledit signal d'étalonnage.

9. Dispositif d'analyse à renouvellement continu selon la revendication 8, dans lequel ladite membrane poreuse est en communication avec des sondes d'étalonnage, lesdites sondes d'étalonnage produisant ledit signal d'étalonnage lorsque se trouvant au sein de ladite zone d'étalonnage.
10. Dispositif d'analyse à renouvellement continu selon la revendication 1, dans lequel le dispositif est un dispositif d'analyse de type sandwich.
11. Dispositif d'analyse à renouvellement continu selon l'une quelconque des revendications 1 à 10, dans lequel lesdites particules microporeuses ont un diamètre moyen compris entre environ 0,1 et environ 100 micromètres.
12. Dispositif d'analyse à renouvellement continu selon l'une quelconque des revendications 1 à 10, dans lequel lesdites particules microporeuses ont un diamètre moyen compris entre environ 1 et environ 10 micromètres.
13. Dispositif d'analyse à renouvellement continu selon l'une quelconque des revendications 1 à 10, dans lequel lesdits éléments de liaison spécifiques sont des anticorps.
14. Dispositif d'analyse à renouvellement continu selon l'une quelconque des revendications 1 à 10, dans lequel ledit réactif de capture est un anticorps.
15. Procédé pour détecter la présence ou quantité d'un analyte se trouvant dans un échantillon à tester, ledit procédé comprenant les étapes consistant à :
- i) fournir un dispositif d'analyse à renouvellement continu comprenant une membrane poreuse, ladite membrane poreuse étant en communication avec des sondes de détection conjuguées capables de produire un signal de détection, des éléments de liaison spécifiques adhérent aux sondes pour former les sondes conjuguées, ladite membrane poreuse définissant une zone chromatographique au sein de laquelle une pluralité de particules microporeuses sont immobilisées et une zone de détection située en aval de ladite zone chromatographique, un réactif de capture étant immobilisé au sein de ladite zone de détection ;
  - ii) mettre en contact un échantillon à tester contenant l'analyte avec lesdites sondes de détection conjuguées de sorte que des complexes analyte/sonde et un analyte non complexé sont formés, et
  - iii) permettre auxdits complexes analyte/sonde et audit analyte non complexé d'atteindre ladite zone chromatographique puis ladite zone de détection, lesdits complexes analyte/sonde atteignant ladite zone de détection avant ledit analyte non complexé.
16. Procédé selon la revendication 15, dans lequel lesdites particules microporeuses définissent une pluralité d'espaces entre elles, lesdits espaces ayant une dimension moyenne qui est supérieure à la dimension moyenne des micropores desdites particules.
17. Procédé selon la revendication 15, dans lequel lesdites particules microporeuses sont sélectionnées dans le groupe consistant en les polystyrènes, les polyacrylamides, les polyacrylonitriles, les billes de silice, et leurs combinaisons.
18. Procédé selon la revendication 15, dans lequel la surface desdites particules microporeuses est inerte chimiquement vis-à-vis de l'analyte.
19. Procédé selon la revendication 15, comprenant en outre la mesure de l'intensité du signal de détection produit au sein de ladite zone de détection.
20. Procédé selon la revendication 15, dans lequel ladite membrane poreuse comprend en outre une zone d'étalonnage capable de produire un signal d'étalonnage, la quantité de l'analyte au sein de l'échantillon à tester étant déterminée à partir dudit signal de détection tel qu'étalonné par ledit signal d'étalonnage.
21. Procédé selon la revendication 20, dans lequel ladite membrane poreuse est en communication avec des sondes d'étalonnage, lesdites sondes d'étalonnage produisant ledit signal d'étalonnage lorsque se trouvant au sein de ladite zone d'étalonnage.
22. Procédé selon la revendication 21, comprenant en outre le traçage d'une courbe d'étalonnage en rapportant l'intensité du signal de détection étalonné par l'intensité du signal d'étalonnage pour une pluralité de concentrations prédéterminées en analyte.

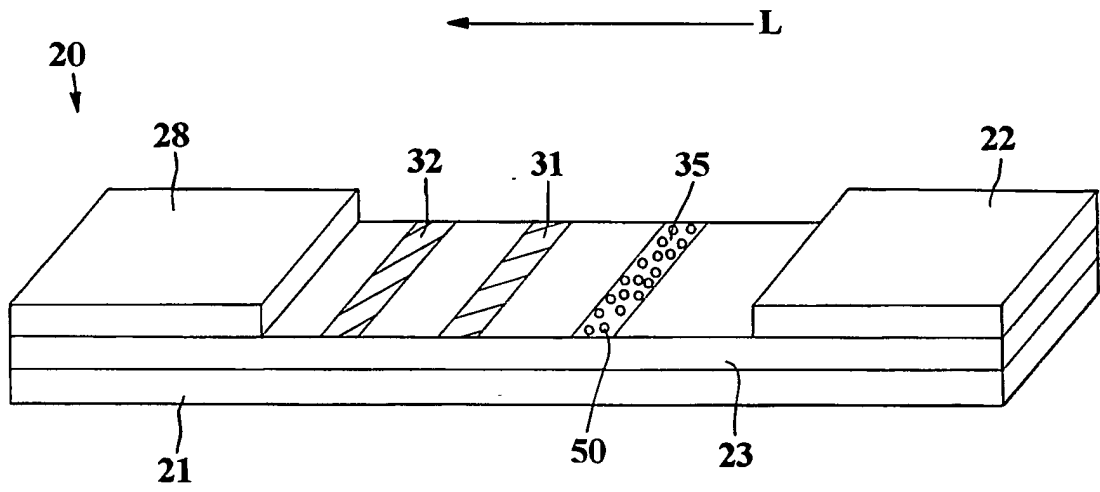

FIG. 1

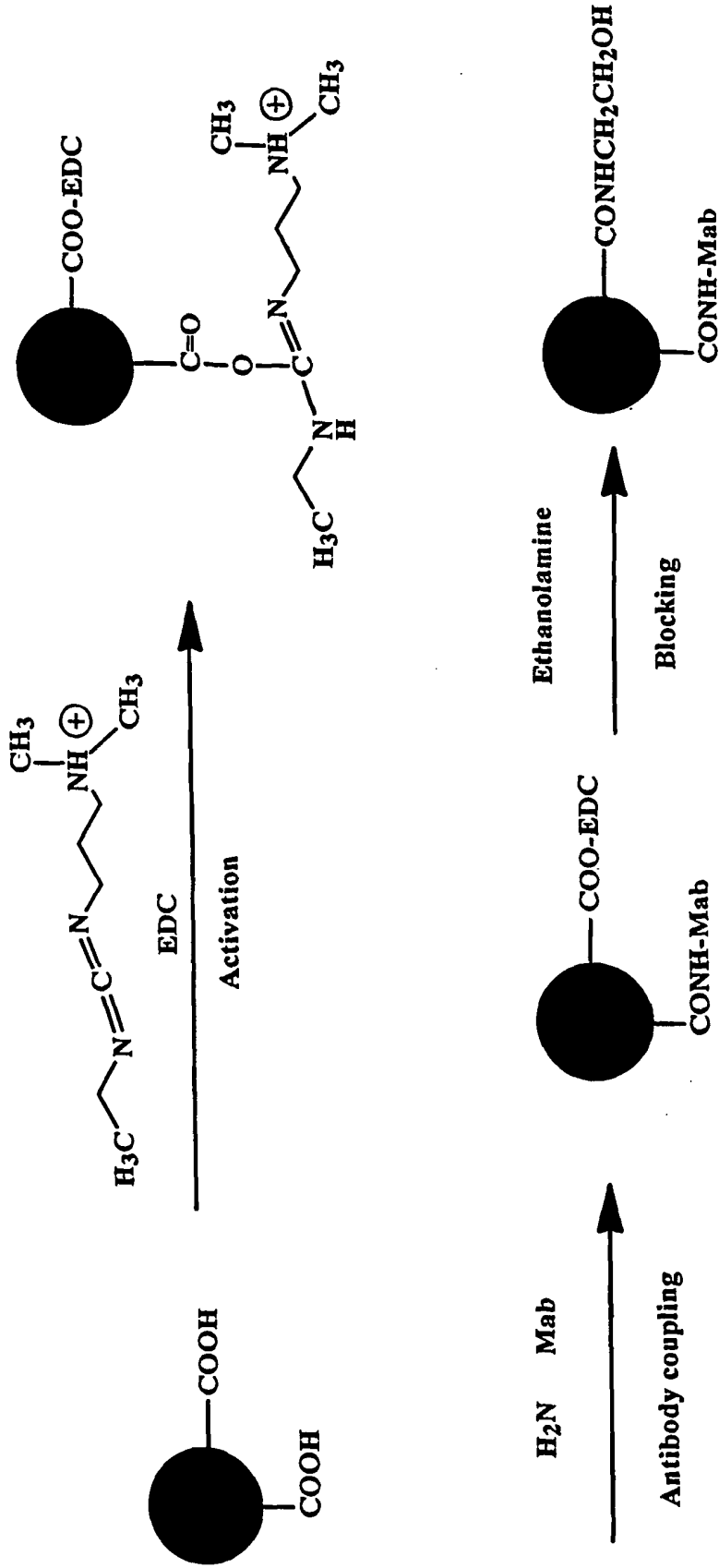

FIG. 2

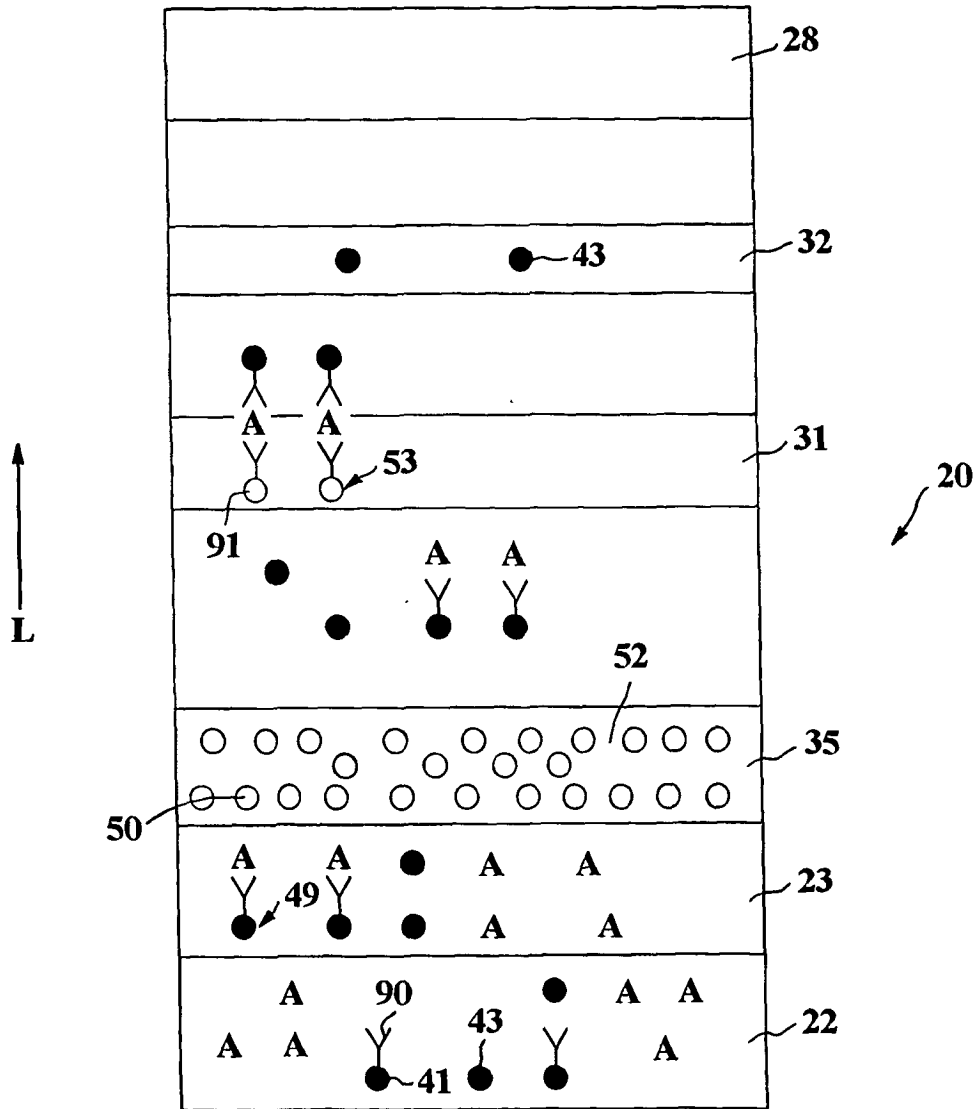

FIG. 3

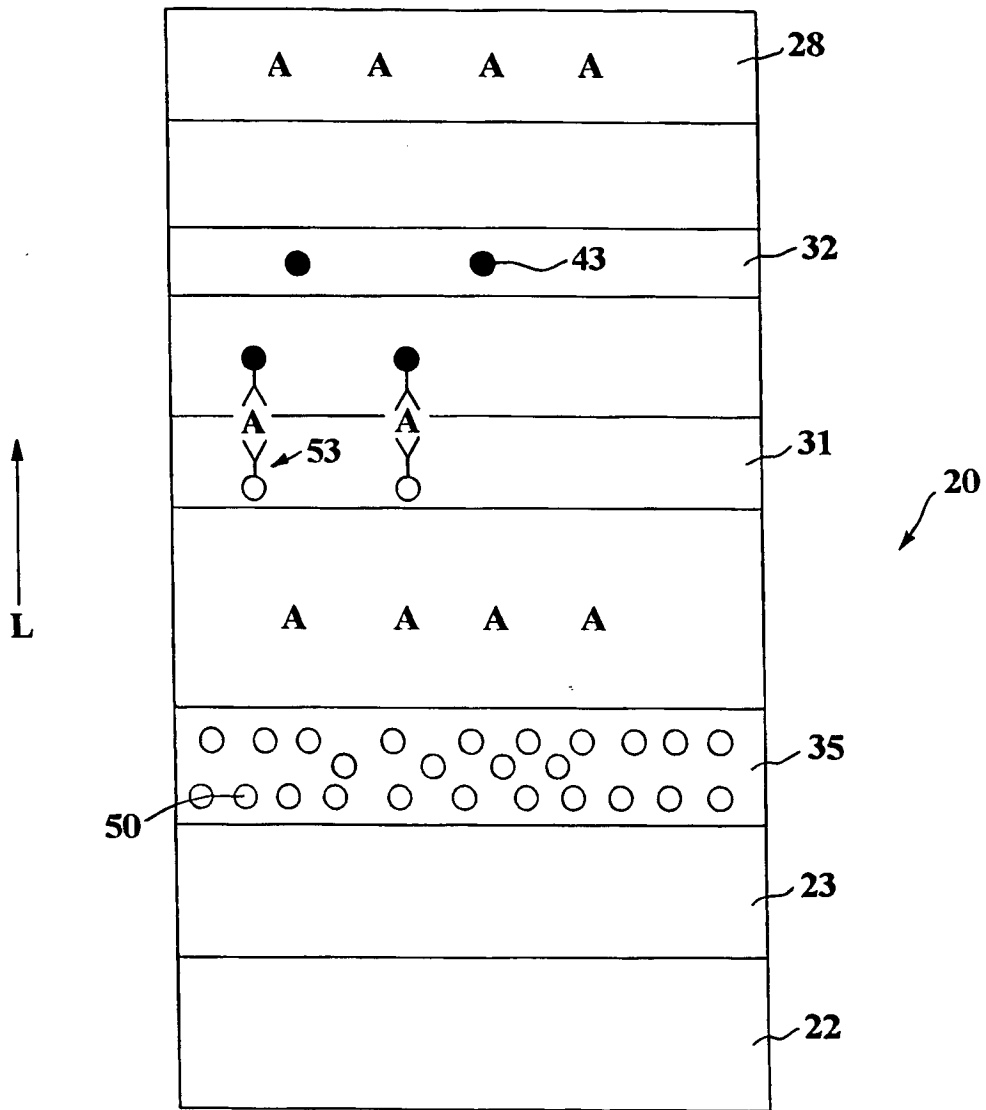

FIG. 4

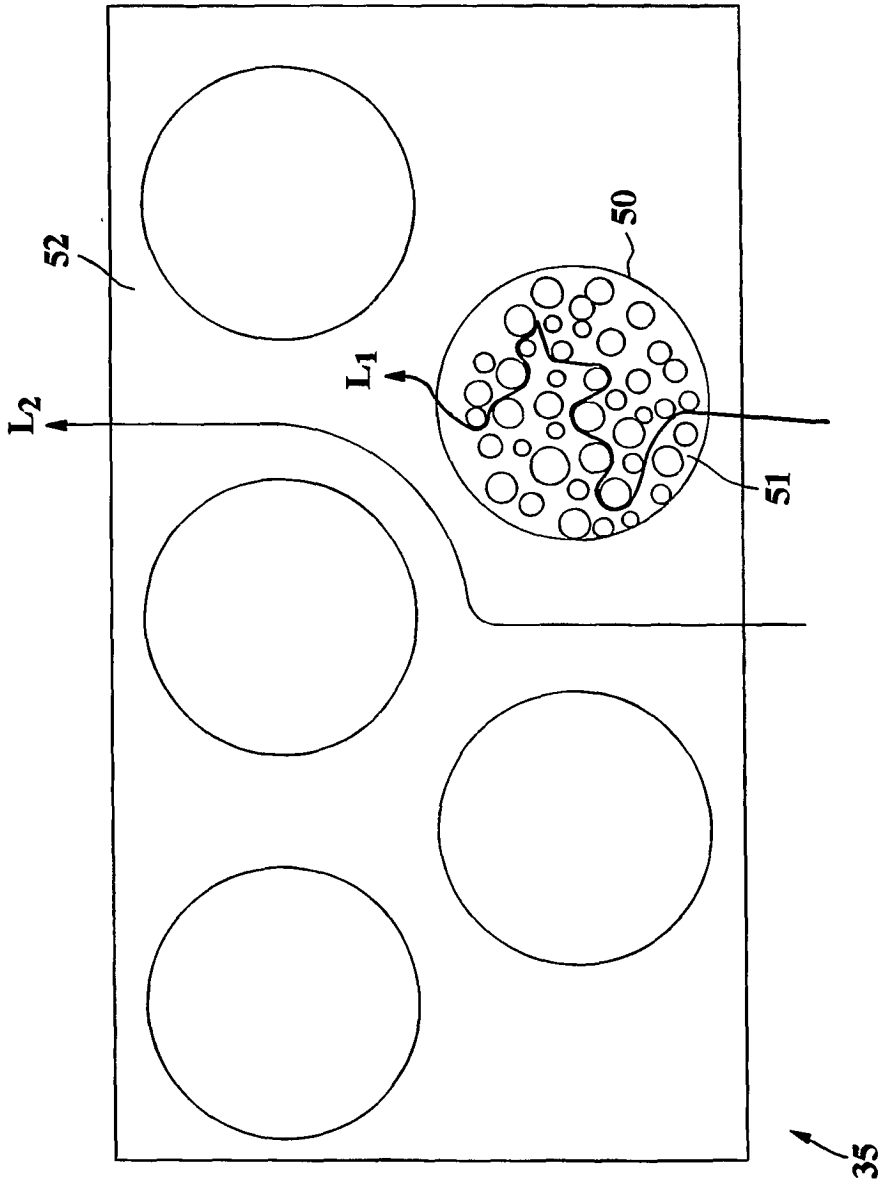

FIG. 5

**REFERENCES CITED IN THE DESCRIPTION**

*This list of references cited by the applicant is for the reader's convenience only. It does not form part of the European patent document. Even though great care has been taken in compiling the references, errors or omissions cannot be excluded and the EPO disclaims all liability in this regard.*

**Patent documents cited in the description**

- US 4168146 A, Grubb **[0002]**
- US 4366241 A, Tom **[0002]**
- US 6184042 B, Neumann **[0004]**
- US 6436651 B, Everhart **[0013]**
- US 4366241 B, Tom **[0013]**
- US 4275149 A, Litman **[0021]**
- US 5670381 A, Jou **[0021] [0023] [0038]**
- US 5252459 A, Tarcha **[0021] [0023]**
- US 4110529 A, Stoy **[0028]**
- US 4940734 A, Ley **[0028]**
- US 5314923 A, Cooke **[0028]**
- US 5395754 A, Lambotte **[0038]**
- US 6194220 A, Malick **[0038]**

专利名称(译)	减少基于膜的测定装置中的钩效应		
公开(公告)号	<a href="#">EP1573326B1</a>	公开(公告)日	2008-09-17
申请号	EP2003783087	申请日	2003-10-29
[标]申请(专利权)人(译)	金佰利-克拉克环球有限公司		
申请(专利权)人(译)	金佰利WORLDWIDE, INC.		
当前申请(专利权)人(译)	金佰利WORLDWIDE, INC.		
[标]发明人	WEI NING HUANG YANBIN		
发明人	WEI, NING HUANG, YANBIN		
IPC分类号	G01N33/543 G01N33/538 G01N33/558		
CPC分类号	G01N33/558 G01N33/538 G01N33/5432 Y10S436/805 Y10S436/809		
优先权	10/325614 2002-12-19 US		
其他公开文献	EP1573326A1		
外部链接	<a href="#">Espacenet</a>		

摘要(译)

提供了一种用于检测驻留在测试样品中的分析物的存在或量的基于膜的测定装置。该装置利用色谱区，在色谱区上设置多个微孔颗粒。色谱区可以以简单，有效且相对便宜的方式有效地减少“钩子效应”。特别地，多个微孔颗粒允许较大尺寸的分析物/探针复合物在未复合的分析物之前到达检测区。因为未复合的分析物基本上被抑制与检测区域处的结合位点的复合物竞争，所以即使在相对高的分析物浓度下，“假阴性”的发生率也可能受到限制。

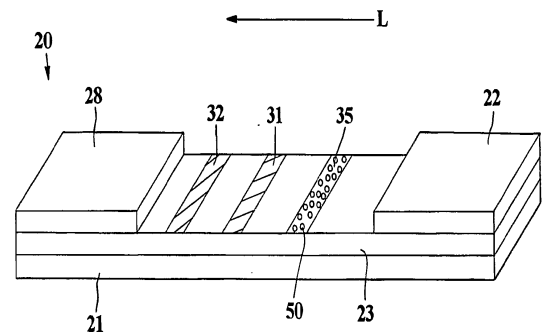

FIG. 1