

(19) World Intellectual Property
Organization
International Bureau



(43) International Publication Date
17 June 2004 (17.06.2004)

PCT

(10) International Publication Number
WO 2004/050825 A2

- (51) International Patent Classification⁷: C12N
- (21) International Application Number: PCT/IL2003/001011
- (22) International Filing Date: 27 November 2003 (27.11.2003)
- (25) Filing Language: English
- (26) Publication Language: English
- (30) Priority Data: 60/429,532 29 November 2002 (29.11.2002) US
- (71) Applicant (*for all designated States except US*): MEISHAR H.Z. YAZAMUT LTD. [IL/IL]; 41 Meishar, 76 850 D.N. Emek Soreq (IL).
- (72) Inventor; and
- (75) Inventor/Applicant (*for US only*): SMILANSKY, Zeev [IL/IL]; 41 Meishar, 76 850 D.N. Emek Soreq (IL).
- (74) Agent: G. E. EHRLICH (1995) LTD.; 11 Menachem Begin Street, 52521 Ramat Gan (IL).
- (81) Designated States (*national*): AE, AG, AL, AM, AT (utility model), AT, AU, AZ, BA, BB, BG, BR, BW, BY, BZ, CA, CH, CN, CO, CR, CU, CZ (utility model), CZ, DE (utility model), DE, DK (utility model), DK, DM, DZ, EC, EE (utility model), EE, EG, ES, FI (utility model), FI, GB, GD, GE, GH, GM, HR, HU, ID, IL, IN, IS, JP, KE, KG, KP, KR, KZ, LC, LK, LR, LS, LT, LU, LV, MA, MD, MG, MK, MN, MW, MX, MZ, NI, NO, NZ, OM, PG, PH, PL, PT, RO, RU, SC, SD, SE, SG, SK (utility model), SK, SL, SY, TJ, TM, TN, TR, TT, TZ, UA, UG, US, UZ, VC, VN, YU, ZA, ZM, ZW.
- (84) Designated States (*regional*): ARIPO patent (BW, GH, GM, KE, LS, MW, MZ, SD, SL, SZ, TZ, UG, ZM, ZW), Eurasian patent (AM, AZ, BY, KG, KZ, MD, RU, TJ, TM), European patent (AT, BE, BG, CH, CY, CZ, DE, DK, EE, ES, FI, FR, GB, GR, HU, IE, IT, LU, MC, NL, PT, RO, SE, SI, SK, TR), OAPI patent (BF, BJ, CF, CG, CI, CM, GA, GN, GQ, GW, ML, MR, NE, SN, TD, TG).
- Published:**
— *without international search report and to be republished upon receipt of that report*
- For two-letter codes and other abbreviations, refer to the "Guidance Notes on Codes and Abbreviations" appearing at the beginning of each regular issue of the PCT Gazette.*



WO 2004/050825 A2

(54) Title: PROTEIN SYNTHESIS MONITORING (PSM)

(57) Abstract: A method and a device are disclosed for monitoring the synthesis of proteins by the ribosome in real time, in-vivo as well as in in-vitro. The ribosome is engineered to carry a donor fluorophore, and tRNA and/or amino acids and/or some other part of the ribosome are either engineered to carry acceptor fluorophores or else their natural fluorescent properties are utilized as acceptors. As the ribosome mechanism processed the mRNA and tRNA molecules and synthesizes a polypeptide chain, a light source illuminates the ribosome, exciting the donor fluorophores and thereby the acceptor fluorophores whenever these are in sufficient proximity to a donor. The resulting data can be tabulated to interpret activity of candidate drugs, elucidate cellular proteomic mechanisms, allow controlled production of proteins, and in general provide a novel, important piece of information central to the solution of the cellular puzzle.

PROTEIN SYNTHESIS MONITORING (PSM)

FIELD OF THE INVENTION

The present invention relates to the monitoring of protein synthesis by ribosomes,
5 and in particular to such monitoring being performed in real time.

BACKGROUND OF THE INVENTION

The study of proteins is a key endeavor of current biological research, as well as a
10 focus of pharmaceutical research and development. The information revealed by sequenced
genomes increases the pace and activity of protein research, for example for the development
of a cell-based assay, analysis of a pathway, study of a single receptor, or the application of
proteomics. Current technologies fail at several key points: they can miss entire protein
families; fail to identify protein pathways; focus on a single protein at a time; and they are
15 expensive, difficult and slow. Importantly, no current technology provides information on
protein dynamics. In fact, results of current large-scale and high-throughput protein analysis
are often delayed by days or weeks following an experiment, and are usually restricted to the
form of a catalogue, tabulating those proteins of a database that have been putatively
identified from the analyzed sample.

20

Genomics, Proteomics and the Barriers of Biological Knowledge

Proteomics is an emerging technology that attempts to study proteins on a large scale
in high-throughput. It is not by chance that the term resembles "Genomics". In the wake of
successful technologies such as whole genome sequencing, DNA chips and SNP cataloging,
25 a search started for similar paradigms in the realm of proteins. This search is worthwhile
since proteins are the main vehicles of life processes: they are the biochemical enzymes,
form the signal pathways, control the cellular processes, underpin the cell scaffolding,
transport molecules and so on. They are also potentially more valuable than DNA in terms of
human benefit, due to their importance in human disease: most known drugs are either
30 proteins themselves, or else operate by binding to a protein target. Unfortunately, proteins
are also so much more complex and difficult to study than DNA. They are more complex for
a number of reasons. For example, there are many more proteins than there are genes;

protein expression is complex and has a high dynamic range – from single copies to millions per cell; the proteome of one cell type may be very different than that of another, even though their DNA is identical; and proteins may undergo dramatic changes in their structure – through cleavage, modification, and interaction. Proteins are more difficult to study than DNA, since protein extraction, separation and identification are difficult; there is no amplification technique that parallels PCR; three-dimensional protein structure is hard to obtain and use; protein expression has high dynamic range; protein modifications, cleavages and interactions are to a large extent unknown; and, finally, both as cause and effect, protein databases are thin and sparsely populated, encompassing a small fraction of all theoretical proteins, especially in higher organisms, such as *Homo sapiens*.

In one aspect, though, Proteomics and Genomics are similar: both raised high hopes of creating a paradigm shift, a breakthrough that will yield a new understanding of cellular processes and human disease, and pave the way to a bounty of new drugs and therapeutics. Unfortunately, first for genomics and then for proteomics, it became abundantly clear that though genomic and proteomic data is extremely valuable, it is far from sufficient for achieving the breakthrough that was hoped for (Miklos, G.L. and Maleszka, R., *Protein functions and biological contexts*. Electrophoresis 22:169-178, 2001). So many pieces of the puzzle are still missing that the clear and complete view of cellular machinery remains hidden. One important piece of this puzzle is protein synthesis data- which proteins are produced at which times, under which conditions, and in which amounts. The ability to study and monitor this type of data would be a major breakthrough for all life science related research.

Proteomics Practice Today

Mainstream proteomic analysis today includes the processes of protein purification from culture, separation with two-dimensional gel or other chromatographic techniques, mass-spectrometry, and analysis of the resulting spectra for protein identification and characterization.

The extraction of proteins from bacterial or cell culture invariably involves lysis (and therefore death) of the cells. The procedure involves several stages and usually takes hours (Branca MA, Sannes LJ. *Proteomics: A Key Enabling Tool for Genomics?* Cambridge Healthtech Institute's Genomic Reports. April 1999; Humphery-Smith I., Cordwell S.J.,

Blackstock W.P., *Proteome research: complementarity and limitations with respect to the RNA and DNA worlds*, Electrophoresis 18 (1997) 1217-1242). Protein separation with two-dimensional gels requires at least 24 hours and an expert human operator; their analysis is often much more difficult, even with modern software (Smilansky, Z. *Automatic registration for images of two-dimensional protein gels*, Electrophoresis 2001, 22, 1616–1626). Even worse, two-dimensional gel technology is not applicable to very acidic or very basic proteins, to many membranal proteins, and most importantly, to proteins that are expressed in low amounts.

It is usually taken for granted that proteins that are expressed at less than 1000-10,000 copies per cell cannot be visualized in two-dimensional gels (Gygi, S.P., Rist, B., Gerber, S.A., Turecek, F., Gelb, M.H., Aebersold, R., *Quantitative analysis of complex protein mixtures using isotope-coded affinity tags*. Nat Biotechnol. 1999, 17(10): 994-9). Almost no protein kinases, phosphatases, transcription factors, GPCRs, ion channels, or nuclear hormone receptors are found in standard human proteomic analyses, even though more than 5000 of these proteins are encoded by the human genome (Miklos, G.L., Maleszka, R. *Protein functions and biological contexts*, Electrophoresis 22:169-178, 2001). Thus, the proteins that can be analyzed by this method are only the most common ones.

Besides separating the sample, two-dimensional gel technology can measure three important protein parameters: mass, pI, and quantity. However, all three are hopelessly inaccurate. As for protein quantity, the most that may be obtained from gel technology is relative quantitation, and even that at accuracies worse than 50% error – so that only proteins with very strong up- or down-regulation can be identified. Moreover, quantitation at best means quantity of protein in the extracted, processed sample, such as in a gel spot or in a chromatographic fraction; estimation of protein copies in a cell at any given time is not even attempted today.

Following protein separation, MS analysis may be performed, either with a MALDI-TOF or with an LC-MS-MS machine (Humphery-Smith I., Cordwell S.J., Blackstock W.P., *Proteome research: complementarity and limitations with respect to the RNA and DNA worlds*, Electrophoresis 18 (1997) 1217-1242; Yates J.R., *Database searching using mass spectrometry data*. Electrophoresis 1998, 19(6): 893-900). The main stages are spot picking from the gel followed by destaining, or alternatively chromatographic prefractionation, followed by protein digestion with a protease (almost invariably trypsin), mass-spectrometric

analysis, and finally database searching, which is performed, surprisingly, only as a semi-automatic procedure with expert supervision and decision making – as in the stages of peak extraction and candidate selection.

5 All in all, the standard technique for identifying proteins in a cell culture takes from weeks to months, is suitable for only a small part of the proteome, does a bad job of quantitating protein amounts, and provides no clue as to proteome dynamics.

Additional and Emerging Proteomics Technologies

10 An important older method for protein analysis is Edman degradation, a chemical analysis method where the C-terminal amino acids of a polypeptide are cleaved and analyzed one by one. The procedure requires a full day and provides no quantitative or dynamic information.

The shortcomings of two-dimensional gel technology have led many researchers to look for alternatives. Two important developments of the last few years are the techniques of
15 ICAT (Gygi, S.P., Rist, B., Gerber, S.A., Turecek, F., Gelb, M.H., Aebersold, R., *Quantitative analysis of complex protein mixtures using isotope-coded affinity tags*. Nat Biotechnol. 1999, 17(10): 994-9) and MudPIT (Washburn, M.P., Wolters, D., Yates JR 3rd. *Large-scale analysis of the yeast proteome by multidimensional protein identification technology*. Nat Biotechnol. 2001 Mar 19(3): 242-7), which involve MS analysis of whole
20 sample digestion products. The two methods allow better identification of rare proteins, and the first one even allows computation of differential expression. However, they are still difficult and expensive to carry out, require cell lysis, take days for complete analysis, and provide no dynamic information.

Protein chips are being developed in several labs (Jenkins, R.E. and Pennington, S.R.
25 *Arrays for protein expression profiling: towards a viable alternative to two-dimensional gel electrophoresis?* Proteomics. 2001 Jan 1(1):13-29). They generally fall into one of three classes: surface chemistry chips, antibody chips, or protein chips for determining protein-protein interactions. All of these may aid protein analysis in some way, but none of them provides the data that the disclosed method provides.

30 Yeast-two-hybrid technique (Y2H) is a feat of bioengineering that helps discover protein-protein interactions (Legrain, P. and Selig, L., *Genome-wide protein interaction maps using two-hybrid systems*. FEBS Lett. 2000 Aug 25; 480(1):32-6). The method is

indirect in that the interactions occur in yeast or in bacteria, rather than in the original cells being analyzed. It is known to generate a large number of false-positives and also cannot generate dynamic information. Thus, there are clearly a number of significant differences between the present invention and the disclosed method.

5

High Throughput Screening and Cell Based Assays

High throughput Screening (HTS) is the standard route for drug discovery in the pharmaceutical industry. Traditionally, HTS relies on a simple assay, such as receptor binding or enzyme activity. The assay itself measures a single parameter, e.g. receptor binding. This measurement is initially the only information available on the suitability of the candidate compound as a potential drug. The rest of the required information – ADME-TOX for example – is either presumed to be known or else its acquisition is delayed till later stages in the process (see also next section).

In contrast with simple assays, cell-based assays are newer to the pharmaceutical industry. They are usually used for lead optimization and predictive toxicology. To construct a cell-based assay, a measurable cell characteristic has to be developed: this can be a fluorescent-tagged protein, an antibody based marker, or some measurable phenotypic characteristic of the cell. Modern examples include cancer-specific dyes (<http://www.zetiq.com/site/cama.html>) and genetically engineered cell lines (Shen-Orr, S.S., Milo, R., Mangan, S., and Alon, U., *Network motifs in the transcriptional regulation network of Escherichia coli*. Nat Genet 2002, 31(1): 64-8; <http://www.cellomics.com/>).

Cell based assays have many advantages over receptor binding assays. Cells offer better representations of a disease. By screening against disease pathways in whole cells, no prior assumptions are made about what makes a good target. However, cell based screening suffers from certain disadvantages. These disadvantages include the need to engineer a specific cell line with the required reporting capability, and the lack of information about the would-be protein target. In both assay types, standard and cell-based assays, high-throughput screening provides a minimal amount of information on a large number of compounds. This of course limits the scope of information obtainable, and the entire cascade of events following administration of the compound under analysis remains hidden from the researcher.

Improved solutions for the above problems are clearly required, for example for pharmaceutical research and development. Despite the huge increase in investment and the enormous contributions of genomics and related technologies, the main difference between the pharmaceutical pipeline today and a decade ago is in the number of targets, while the number of successful drugs entering the market has more or less stayed the same. More discouraging yet is the fact that while advances in high-throughput screening, chemical compound library design and bioinformatics have helped multiply the number of “hits” in HTS assays, the number of “leads” has not increased at all. Thus, the pharmaceutical pipeline today has an abundance of targets on the one side and an abundance of candidate compounds on the other, but attempts to combine this information has yielded little.

Though there is more than one reason for this failure, one important point is that though the numbers of targets and candidates is huge, the complexity of the cellular machinery, not to mention tissue and whole organism, is on a grander scale still. Thus, a better view of function and context of a protein target in the cell, as well as the complex effects, side effects, and after effects of a drug compound on the cell, are all clearly missing.

In today’s paradigm of drug development, once a target is found and a compound that binds to it is identified, drug development starts to proceed toward towards regulatory approval and market acceptance. While the process is long and very expensive, it is narrow in the sense that relatively little is known about the target protein, its function, its isoforms and look-alikes, its roles in disease and in health. Even less is known about the drug candidate, how it affects proteins other than its specified target, how it affects other tissues, its immediate effects and its long term effects. Thus, information that may indicate that a compound cannot become a suitable drug candidate is revealed only at later stages and at a high cost – sometimes only after being distributed on the market. Among the medications which had to be recalled after market approval are the nighttime heartburn drug Propulsid (removed because of fatal heart rhythm abnormalities), diabetes drug Rezulin (removed after causing liver failure), and irritable-bowel-syndrome treatment Lotronex (removed for causing fatal constipation and colitis). All three were taken off the market in 2000.

SUMMARY OF THE INVENTION

The background art does not teach or suggest an assay for monitoring protein synthesis as it occurs, in real time. The background art also does not teach or suggest such an assay which is sensitive and which is also reliable as a whole-cell assay.

5 The present invention overcomes these disadvantages of background art by providing a system and method for monitoring protein synthesis in a protein synthesis system, preferably by determining the identity of the protein being synthesized at the given instant. The method of the present invention is also referred to herein as "PSM" (protein synthesis monitoring). Protein synthesis is monitored by using a marker or a set of markers for protein
10 synthesis in the system, which preferably cause electromagnetic radiation to be emitted. The emitted electromagnetic radiation is then detected and can be analyzed to detect protein synthesis. The present invention may optionally be performed qualitatively, but is preferably performed quantitatively. The marker may optionally include any type of label or tag, or a pair of such labels or tags, or a donor/acceptor pair or a set of one donor and several types of
15 acceptors (each one with a different emission wavelength), or a set of several donor types and one acceptor, or several donors and acceptor types, for example.

 The synthesis marker preferably enables the present invention to detect which tRNA is currently being processed by a ribosome, which mRNA codon is being read, or which amino acid is currently being added to the nascent protein. This signal can optionally and
20 preferably be captured and analyzed in seconds to reveal the protein's identity. The procedure can optionally be performed for hundreds of ribosomes simultaneously, and so provide, for the first time in biology, a tool for dynamic monitoring of protein synthesis.

 With such a tool, the effects of potential drugs can be assayed to determine the proteins that are being up- or down-regulated by a compound, as well as to determine the
25 sequence of events; protein pathways can be identified by interpretation of the changing translation patterns, noting which proteins are just beginning to be translated and which are ceasing to be translated; rare, hydrophobic, and heavy proteins can be identified at the same efficiency as any other protein; cell-free translation systems can be monitored in real-time and protein production processes can be monitored and optimized. These procedures may
30 optionally be performed in seconds rather than days, with a single type of engineered cell (from a given cell-line) that is as near to a natural, non-engineered cell as possible, and with the benefit that performing a PSM assay with this cell-line may provide a huge amount of

information on the compound being tested. These capabilities are in strong contrast with the multitude of specialty, heavily engineered cell types that are required today. Indeed, the present invention may optionally provide a "universal assay" for drug discovery and development on the one hand, as well as an indispensable tool for basic and applied scientific biological and pharmaceutical research and production.

According to preferred embodiments of the present invention, there is provided a method and device for measuring and monitoring protein synthesis by the ribosome in real time, preferably *in-vivo* as well as in *in-vitro* translation systems. In the present invention, the ribosome is engineered to carry a donor fluorophore in a prescribed configuration, and tRNA and/or amino acids and/or another part of the ribosome are engineered to carry acceptor fluorophores and/or their natural fluorescent properties are utilized. Donor and acceptor are selected so that the donor can transfer energy to the acceptor when the donor is excited and the acceptor is in close proximity to the donor. As the ribosome mechanism reads the mRNA information, processes tRNA molecules and synthesizes a polypeptide chain, a light source illuminates the ribosome, exciting the donor fluorophores and thereby the acceptor fluorophores which are within sufficient proximity of corresponding donors. The resulting signals are detected by appropriate optical apparatus and collected by a computerized analysis system as digital data. This digital data is optionally and preferably used as a key for database searching and identification of the protein being synthesized at that moment.

Protein synthesis information can optionally be tabulated to correlate with chemical or environmental effects applied to the cells being studied. In this way the present invention is able to decipher the functionality of chemical compounds; elucidate cellular proteomic mechanisms; control protein production systems; and help study the factors affecting protein synthesis.

The present invention has many advantages, of which only a few are listed herein. These advantages include but are not limited to, real-time, optionally *in-vivo*, monitoring of protein synthesis, unprecedented sensitivity, highly accurate quantitation, the ability to monitor cellular events through protein synthesis, the ability to complement other methods such as protein tagging for monitoring protein localization and degradation, elucidation of protein pathways and interactions, and support of protein function analysis. The present

invention can also optionally be used to monitor protein production and assist in process optimization and control.

The present invention also has the advantage of providing an assay for protein synthesis which is optionally cell based. As noted above, cell based assays have many advantages over receptor binding assays. Cells offer better representations of a disease. By screening against disease pathways in whole cells, no prior assumptions are made about what makes a good target. However, cell based screening assays, as for other screening assays, provide only a binary, or yes/no answer, for a given compound. This type of answer limits the scope of information obtainable, and causes the entire cascade of events following administration of the compound under analysis to remain hidden from the researcher. These limitations are in strong contrast to the PSM assay method of the present invention that is disclosed herein, where upon administration of the compound, no special preparations are required (besides optionally using cells that were prepared for PSM), no assumptions are required, and protein synthesis processes can be followed to gain a more complete understanding of the cell's response to the chemical or environmental stimulus that was applied.

The present invention has a number of other, additional advantages over background art techniques. For example, the present invention provides comprehensive information about protein production in the cell, showing precisely how, when, in what order and in what amounts does the cell respond to the compound following administration. The target itself can be seen in the context of other proteins that are co-synthesized with it, before it, or after it; connections with other proteins can be identified. Similarly, the compound can be seen in the context of other compounds that elicit a similar response, allowing SAR and QSAR analyses to be performed.

Furthermore, apart from the hitherto unavailable information that the present invention provides, the technique holds the important promise of both widening and shortening the drug development process by early removal of compounds from the pipeline, by providing a much larger amount of information about a candidate drug much earlier in the process, and by allowing more compounds and targets to enter this process. Thus, the present invention has the potential to produce many more drugs in shorter time and with smaller expenditure.

Another important application of the present invention is as a tool for process optimization, process control and quality control of protein production, either in bio-reactors using bacteria or cell culture, or else in cell free translation systems. In these situations, the present invention can provide indispensable information about the amounts of the target protein being produced, as well as on the precise structure of the proteome backdrop to this manufacturing, ensuring that the desired protein is produced in precisely the required environment. This level of control, unavailable today, can create a revolution in the way proteins and protein drugs are produced and certified. This can lead to new protein production methods that are easier to control than current ones.

According to the present invention, there is provided a method for monitoring protein synthesis in a protein synthesis system, the method comprising: providing a marker for protein synthesis in the system, the marker being detectable through detection of electromagnetic radiation; detecting electromagnetic radiation emitted from the system; and analyzing the emitted radiation to monitor protein synthesis activity in the system.

Preferably, the system comprises a bacterium or bacterial culture. Also preferably, the system comprises at least one cell. More preferably, the system comprises at least one of a cell-line or a cell culture.

Optionally and preferably, the system comprises a cell-free protein translation system (*in-vitro* translation system). Preferably, one or more of ribosomes, ribosomal RNA, ribosomal proteins, tRNAs, or amino acids in the system are artificially adapted to provide the marker.

Preferably, the marker comprises at least a portion of one or more of natural ribosomes, ribosomal RNA, ribosomal proteins, tRNAs, or amino acids.

According to a preferred embodiment of the present invention, the marker comprises at least one photo-active component. Preferably, the emitted radiation comprises radiation obtained by energy transfer between at least two of a plurality of components of the system. More preferably, the marker comprises at least one fluorescent donor-acceptor pair. Also more preferably, the emitted radiation comprises a FRET (Fluorescence resonance energy transfer) signal.

Preferably, the emitted radiation comprises a fluorescent signal.

Also preferably, at least a portion of the marker comprises at least one of a fluorescent protein, a fluorescent dye, a quantum dot or a luminescent substance. More preferably, the luminescent substance comprises a luminescent protein or portion thereof.

Preferably, the marker comprises a first portion being a fluorescent substance and a
5 second portion for quenching the fluorescent substance. More preferably, the detecting comprises detecting a reduction in emitted radiation.

Preferably, at least a portion of the marker is covalently or non-covalently bound to a tRNA. Also preferably, at least a portion of the marker is covalently or non-covalently bound to at least a portion of a ribosome. More preferably, the portion of the ribosome is at
10 or near at least one of the A site, P site, E site or peptide exit channel site. Most preferably, the at least a portion comprises an amino acid.

Optionally and preferably, the detecting comprises irradiating the system with electromagnetic radiation.

Also optionally and preferably, the emitted radiation is detected with a microscope.

Also optionally and preferably, the method is adapted to measure emitted radiation
15 from a single ribosome. More preferably, the marker comprises a donor-acceptor fluorescent pair suitable for performing single pair FRET and wherein the emitted radiation occurs upon performing single pair FRET.

Preferably, the method is adapted to measure signals from a plurality of ribosomes.
20 More preferably, the analyzing the emitted radiation comprises performing signal analysis of emitted radiation from the plurality of ribosomes.

Preferably, the method further includes identifying at least one protein being synthesized through the analyzing the emitted radiation.

Preferably, the detecting is performed in real time.

Also preferably, the detecting further comprises: monitoring protein synthesis by
25 detecting a plurality of protein synthetic processes over a period of time. More preferably, the plurality of protein synthetic processes comprise a plurality of interactions between a ribosome and a plurality of different tRNA molecules.

According to another embodiment of the present invention, there is provided a
30 apparatus for measuring protein synthesis by a protein synthesis system, the apparatus comprising: a container for containing a plurality of components for the system, wherein at least one component is capable of emitting electromagnetic radiation due to a protein

synthesis activity; a detection system to measure emitted radiation from the system; and a computational device to analyze the emitted radiation and determine the protein synthesis activity in the system.

Preferably, the system comprises a bacterium or bacterial culture. Preferably, the system comprises at least one cell. More preferably, the system comprises at least one of a cell-line or a cell culture.

Preferably, the system comprises a cell-free protein translation system (*in-vitro* translation system).

Also preferably, one or more of ribosomes, ribosomal RNA, ribosomal proteins, tRNAs, or amino acids in the system are artificially adapted to provide the marker.

Preferably, the marker comprises at least a portion of one or more of natural ribosomes, ribosomal RNA, ribosomal proteins, tRNAs, or amino acids.

Also preferably, the marker comprises at least one photo-active component. More preferably, the emitted radiation comprises radiation obtained by energy transfer between at least two of a plurality of components of the system. Most preferably, the marker comprises at least one fluorescent donor-acceptor pair. Also most preferably, the emitted radiation comprises a FRET (Fluorescence resonance energy transfer) signal.

Preferably, the emitted radiation comprises a fluorescent signal. Also preferably, at least a portion of the marker comprises at least one of a fluorescent protein, a fluorescent dye, a quantum dot or a luminescent substance. More preferably, the luminescent substance comprises a luminescent protein or portion thereof.

Preferably, the marker comprises a first portion being a fluorescent substance and a second portion for quenching the fluorescent substance. More preferably, the detection system detects a reduction in emitted radiation.

Preferably, at least a portion of the marker is covalently or non-covalently bound to a tRNA.

Also preferably, at least a portion of the marker is covalently or non-covalently bound to at least a portion of a ribosome. More preferably, the portion of the ribosome is at or near at least one of the A site, P site, E site or peptide exit channel site. Also more preferably, the at least a portion comprises an amino acid.

Preferably, the detection system irradiates the system with electromagnetic radiation.

Also preferably, the detection system comprises a microscope.

Preferably, the detection system measures emitted radiation from a single ribosome. More preferably, the marker comprises a donor-acceptor fluorescent pair suitable for performing single pair FRET and wherein the emitted radiation occurs upon performing single pair FRET.

5 Preferably, the detection system measures a plurality of signals from a plurality of ribosomes. More preferably, the computational device performs signal analysis of emitted radiation from the plurality of signals.

Preferably, the apparatus includes equipment, for example in the detection system, for identifying at least one protein being synthesized through the analyzing the emitted radiation.

10 Preferably, the detection system operates in real time.

Also preferably, the detection system monitors protein synthesis by detecting a plurality of protein synthetic processes over a period of time. More preferably, the plurality of protein synthetic processes comprise a plurality of interactions of a single ribosome with a plurality of different tRNA molecules.

15 According to a preferred embodiment of the present invention, there is provided a method for analyzing a chemical compound library, the method comprising: administering each of the compounds to a protein translation system; measuring a response of the system according to the method described above; and analyzing the measurement to provide information about the compound.

20 According to another preferred embodiment of the present invention, there is provided an apparatus for analyzing a chemical compound library, comprising: a well array plate comprising a plurality of wells; a robot for placing a protein synthesis system into the wells; a robot for administering chemical compounds into the wells; and an apparatus as previously described to analyze protein synthesis by the system.

25 According to still another preferred embodiment of the present invention, there is provided a method for determining cellular protein pathways, comprising: selecting a cellular or bacterial culture; placing the culture in a plurality of sample containers; subjecting the culture to at least one condition in each of the containers; measuring protein synthesis in each of the containers as previously described; and analyzing protein expression patterns in all
30 containers to determine protein pathways.

According to yet another preferred embodiment of the present invention, there is provided a method for ribosome labeling to allow protein synthesis monitoring, the method

comprising: selecting a fluorescent probe; selecting a location on at least one of a ribosomal RNA or on a ribosomal protein according to at least one of a characteristic of the probe or a characteristic of at least one of the ribosomal RNA or the ribosomal protein; and attaching the probe to the location. Preferably, the selecting the fluorescent probe is performed according to at least one of a suitable excitation or emission property of the probe.

According to another preferred embodiment of the present invention, there is provided a method for protein production monitoring, the method comprising: selecting a protein synthesis system for PSM analysis; selecting a fluorescent probe; selecting a location on at least one of a ribosomal RNA or on a ribosomal protein according to at least one of a characteristic of the probe or a characteristic of at least one of the ribosomal RNA or the ribosomal protein; attaching the probe to the location to perform PSM; and analyzing signals from the probe to monitor the protein synthesis system.

According to still another preferred embodiment of the present invention, there is provided a method for detecting protein synthesis in a protein synthesis system, the method comprising: providing a marker for protein synthesis in the system, the marker having a label; attaching the marker to at least one component of the system; and detecting the label to determine protein synthesis activity in the system.

According to a preferred embodiment of the present invention, there is provided use of a marker for detecting a protein synthetic act in real time. Preferably, the protein synthetic act comprises an interaction between a tRNA and a ribosome. More preferably, at least one of the ribosome and the tRNA features a marker. Most preferably, both the ribosome and the tRNA feature the marker. Also most preferably, the tRNA comprises a naturally fluorescent amino acid.

Preferably, the ribosome comprises a label. More preferably, the label comprises a quantum dot.

Preferably, each of the ribosome and the tRNA features a portion of a marker. More preferably, a first portion comprises a fluorescent acceptor and a second portion comprises a fluorescent acceptor.

Preferably, if the ribosome comprises a marker or a portion thereof, the marker or the portion thereof is covalently or non-covalently bound to ribosomal protein L1, ribosomal protein S1 or a combination thereof.

More preferably, the use is for performing a screening assay according to the detecting the protein synthetic act. Also more preferably, the screening assay is for detecting a pathological condition in a subject.

5 More preferably, the use is for pathway elucidation through the detecting the protein synthetic act.

Also more preferably, the use is for cell state analysis through the detecting the protein synthetic act.

10 According to a preferred embodiment of the present invention, there is provided use of a marker for identifying a protein being synthesized by a protein synthetic process in real time. According to a preferred embodiment of the present invention, there is provided use of a marker for identifying a tRNA species being used in a protein synthetic process in real time.

15 According to a preferred embodiment of the present invention, there is provided use of a marker for identifying an amino acid species being used in a protein synthetic process in real time.

According to a preferred embodiment of the present invention, there is provided use of a marker for identifying a codon species being used in a protein synthetic process in real time.

20 In order to better describe the disclosure, current technologies that the invention may optionally use are briefly explained. It should be noted that all references given in this application are hereby incorporated by reference as if fully set forth herein.

Fluorescent Resonance Energy Transfer (FRET)

25 Fluorescence resonance energy transfer – FRET- has been known for over 50 years (Ha, T., *Single-molecule Fluorescence resonance energy transfer*, Methods 25, 78-86 (2001), review; De Angelis, D.A., *Why FRET over genomics?* Physiol. Genomics 1999, 31; 1(2): 93-9; Selvin, P.R., *The renaissance of fluorescence resonance energy transfer*, Nat. Struct. Biol. 2000 Sep;7(9):730-4; Kenworthy, A.K., *Imaging Protein-Protein Interactions*
30 *Using Fluorescence Resonance Energy Transfer Microscopy*, Methods. 2001 Jul;24(3):289-96). The technology allows measurement of distances in the nanometer scale up to about 10 nanometers. It relies on a quantum-mechanical principle where, under suitable conditions, energy is transferred between molecules without photon exchange. For FRET to occur, a

donor fluorophore is excited by incident light while an acceptor fluorophore is nearby. The emission spectrum of the donor must overlap with the excitation spectrum of the acceptor. In this configuration, some of the energy is transferred from donor to acceptor without generation of photons. This causes the excitation of the acceptor molecule, and consequently the emission of a fluorescent photon in the natural fluorescent frequency of the acceptor. Thus, when FRET occurs, donor emission decreases and acceptor emission increases as the distance between them diminishes. The energy transfer efficiency obeys the relationship $E \propto [1 + (R/R_0)^6]^{-1}$, where R is the distance between donor and acceptor and R_0 is a constant that depends on donor-acceptor configuration and characteristics.

Figure 1 shows a diagram of FRET pair configuration. In Figure 1A the spectral graphs of donor excitation **250**, donor emission **252**, acceptor excitation **254** and acceptor emission **256** are shown. Note the overlap between the spectral responses of donor emission and acceptor excitation. In Figure 1B the efficiency of energy transfer is shown as a function of donor-acceptor normalized distance (R_0 is equivalent to 50 in this chart).

FRET has been recently used to sequence DNA (Bralavsky, I., *Sequence information can be obtained from single DNA molecules*, Proc Natl Acad Sci U S A., 2003 Apr 1;100(7):3960-4.), monitor cellular events in live cells (Zlokarnik *et al.*, *Quantitation of transcription and clonal selection of single living cells with beta-lactamase as reporter*, science 1998 Jan 2;279(5347):84-8)), create sensitive biochemical sensors (Medintz *et al.*, *Self-assembled nanoscale biosensors based on quantum dot FRET donors*, Nat Mater. 2003 Sep;2(9):630-8), perform real time sequencing of DNA or RNA (PCT application WO 01/16375 to Schneider and Rubens) and monitor protein-protein interactions or protein kinetics (Jia *et al.*, *Nonexponential kinetics of a single tRNA-Phe molecule under physiological conditions*. Proc Natl Acad Sci U S A. 1997 Jul 22;94(15):7932-6). Numerous ingenious variants of the technique have been used successfully both *in-vitro* and *in-vivo*, both in bulk and in single molecule setting. One common application is the real-time monitoring of inter-molecular distances. Indeed, using FRET, it is becoming common nowadays to observe dynamics of single molecular events, in real time, in living cells.

In one preferred embodiment, FRET architecture makes use of a donor-quencher pair rather than a donor-acceptor architecture; for this optional embodiment, the donor-quencher pair forms the marker. This implementation is a more robust architecture, allowing the use of

metal and other particles instead of fluorescent biomolecules. In this embodiment, the signal measured is in fact the donor signal, interrupted by periods of quenching.

The ribosome and the mechanism of translation

5 The structure of the ribosome and the mechanism of translation, as have been revealed by recent work, are reviewed herein (Alberts, B., Johnson, A., Lewis, J., Raff, M., Roberts, K., and Walter, P., *Molecular Biology of the Cell*, 4th ed, 2002, Garland Science, N.Y.; Ramakrishnan, V., *Ribosome Structure and the Mechanism of Translation*, 2002, Cell 108 557-572; Schlunzen, F. *et al.*, *Structural basis for the interaction of antibiotics with the*
10 *peptidyl transferase center in eubacteria*, 2001, Nature 413 814-821; Sytnik, A. *et al.*, *Peptidyl Transferase Center Activity Observed in Single Ribosomes*, 1999, J. Mol. Biol. 285, 49-54; Nyborg, J., and Liljas, A., *Protein biosynthesis: structural studies of the elongation cycle*, 1998, FEBS letters 430, 95-99).

15 The ribosome itself is composed of two subunits, termed 30S and 50S (there are differences between bacterial and eukaryotic ribosomes— henceforth in this discussion the ribosome is presumed to come from *E. coli*, although this assumption is made for the purposes of description only and without any intention of being limiting in any way). The large unit is composed of a pair of large RNA molecules (5S and 23S), the small subunit of a single RNA molecule (30S). Each unit has several dozen small proteins attached to it
20 (Alberts, B., Johnson, A., Lewis, J., Raff, M., Roberts, K., and Walter, P., *Molecular Biology of the Cell*, 4th ed, 2002, Garland Science, N.Y.). The ribosome reads the code on mRNA molecules and synthesizes the encoded protein through the mediation of tRNA molecules. The process is performed in three stages: initiation, elongation and termination.

25 The ribosome uses an adaptor molecule – transfer RNA, or tRNA. These molecules are a special type of RNA. At one end, they have the anticodon part that binds to the RNA codon. At the other end, they carry the amino acid corresponding to that codon. Figure 2A shows a tRNA molecule **2**, with the anticodon loop **4**, the amino acid arm **6**, and a loaded amino acid **8**. The tRNA molecules have a cycle of being charging with amino acid and discharging. Charging, or attachment of amino acids to the tRNA molecules, is performed by
30 the aminoacyl-synthetase enzyme family. Discharging is performed by the ribosome, serving as a ribozyme (RNA enzyme).

When tRNA is tagged (as for example with a fluorescent label), the tRNA should continue to function normally during the processes of becoming charged with an amino acid,

attaching to the elongation factors, and traveling through the ribosome. Several tagging schemes have made use of the shoulder **10** of the molecule in order to create fluorescent labeling schemes that are efficient on the one hand and result in a fully functional tRNA molecule on the other hand. Several studies have shown that *E. coli* tRNAs (tRNA molecules) can be efficiently labeled at position 8, which has in many cases a 4-thiouridine base, and at position 47, which has in several cases an amine-reactive X-base (see table below; it should be noted that these position numbers are given according to a standard numbering system for tRNA molecules). tRNA functionality requires that the molecule interact properly with the aminoacyl synthetases on the one hand, and with the ribosomal machinery (including the elongation factors) on the other. tRNA recognition by aminoacyl synthetases is known to be particularly dependent on the anticodon part and the amino acid arm locus.

There are three important stages in translation: initiation, elongation and termination. For monitoring protein synthesis, where protein identification is a preferred motivation, the important stage is elongation. Figure 2B shows a schematic description of bacterial ribosome structure with the larger (50S) subunit **20**, smaller (30S) subunit **25**, aminoacyl (A) site **50** where tRNAs dock initially, peptidyl (P) site **51** where the growing polypeptide chain is docked, and exit (E) site **52** from where the deacylated tRNA is removed once the cycle is complete. Also shown are tRNAs that are undocked yet **40** and **41** to show that the cycle may continue further, mRNA being decoded **30** and the nascent polypeptide chain being synthesized **45**. The ribosome itself is made up of large folded rRNA chains with ribosomal proteins. The larger subunit **20** contains two folded rRNAs, known as 23S and 5S. The smaller subunit **25** contains one folded rRNA, 30S (not shown). On the folded rRNA chains more than 50 ribosomal proteins are docked (not shown). They are customarily denoted by L1, L2 etc for the approximately 36 ribosomal proteins attached to the large subunit, and by S1, S2 etc for the approximately 21 ribosomal proteins attached to the small subunit (numbers given are correct for *E. coli* ribosomes).

Three docked tRNAs are seen in Figure 2B. The first **42** is in the A (Aminoacyl) site; the second **43** in the P (Peptidyl) site, and the amino acid it carries is at this point connected to the nascent peptide; the third **44** is in the E (exit) site, it has been discharged from the amino acid and will be ejected shortly from the ribosome. The heavy line **30** indicates the

mRNA being translated, and the dotted line 45 represents the polypeptide being synthesized, tied into the Peptidyl position.

The main stages of elongation are as follows. Stage 1: Codon recognition. A tRNA molecule carrying an amino acid binds to a vacant A-site, while the nascent polypeptide is attached to the P-site. Stage 2: Peptide bond creation. A new peptide bond is created and the polypeptide chain is moved to the A-site. Stage 3: Translocation. The ribosome translocates a distance of 3 nucleotides with respect to the mRNA, the two tRNA units and the polypeptide chain. Stage 4: the cycle repeats itself until a stop codon is reached.

This cycle is shown as schematic diagrams in Figures 3A-3C. Stage 1 – Codon recognition- is shown in Figure 3A. A tRNA molecule 800 carrying an amino acid 802 binds to a vacant A-site 820, while the growing polypeptide chain 810 is attached to amino acid 806 on tRNA 804 that is docked in the P-site 822. At this stage E site 824 is shown as empty. Stage 2, peptide bond formation, is shown in Figure 3B. A new peptide bond is created between amino acid 806 and amino acid 802, and the polypeptide chain 810 is moved to the A-site 820. Stage 3, translocation, is shown in Figure 3C. The ribosome translocates 3 nucleotides with respect to the mRNA, the two tRNA units 800 and 804, and the polypeptide chain 810. Stage 4: the cycle repeats itself until a stop codon is reached.

Single molecule detection

In recent years, the technology of single molecule detection by fluorescent spectroscopy has advanced considerably. This has been aided by novel microscopy methods; improved radiation sources, cameras and detectors; novel, highly efficient fluorescent labels in the visible range; and novel labeling techniques. The achievements of single molecule fluorescent spectroscopy are numerous. It has allowed us to measure dynamic behavior and reaction kinetics of individual biological molecules inside living cells, and provided a direct way to quantify, with a high spatial and temporal resolution, biological events inside cells at the single-molecule level. Kinetics of a single molecule have been demonstrated (Zhuang *et al.*, *Correlating structural dynamics and function in single ribozyme molecules*. Science. 2002 May 24;296(5572):1473-6), individual ion channels have been studied *in-vivo* (Harms, G.S. *et al.*, *Single-Molecule Imaging of L-Type Ca²⁺ Channels in Live Cells*, 2001, Biophysical Journal 81, 2639-2646), DNA sequencing has been performed using optical methods with single DNA molecules (Braslavsky *et al.*, *Sequence information can be obtained from single DNA molecules*, Proc Natl Acad Sci U S A. 2003 Apr 1;100(7):3960-4)

translation by single ribosomes has been observed and measured (Vanzi *et al.*, *Protein synthesis by single ribosomes*, RNA (2003), 9:1174–1179), Ribosome activity was measured in single ribosomes (A. Sytnik *et al.*, *Peptidyl Transferase Center Activity Observed in Single Ribosomes*, J. Mol. Biol. 285, 49 (1999), protein denaturation has been studied (Deniz, A.A., *et al.*, *Single-molecule protein folding: Diffusion fluorescence resonance energy transfer studies of the denaturation of chymotrypsin inhibitor 2*, 2000, PNAS 97 (10), 5179-5184). Numerous additional applications have been reported: direct observation of the motions of molecular motors, enzymatic reactions, structural dynamics of proteins and DNA-protein interactions *in-vitro*; single lipid molecules in a lipid bilayer have been visualized, ligand-receptor reactions and lipid molecule movements have been visualized as single molecules on the surface of living cells. The technique has been reviewed extensively, as, for example, in the following references, incorporated herein in their entirety as if fully set forth: Sako, Y., and Yanagida, T, *Single-molecule visualization in cell biology*, Nat Rev Mol Cell Biol. 2003 Sep;Suppl:SS1-5. Review; Schwille, P. and Kettling, U., *Analyzing single protein molecules using optical methods*, 2001, Current Opinion Biotech., 12:382-386; Weiss, S., *Fluorescence Spectroscopy of Single Biomolecules*, 1999, Science 283, 1676-1683.

Most important for the present invention is the technology of single molecule FRET detection (single pair FRET - spFRET). In this technique, FRET pairs are attached to the biomolecules of interest, whether *in-vitro* or *in-vivo*, and observed by a single-molecule microscopy system. If the FRET pairs are separated by distances that are within the resolution limit of the imaging device, single interactions can be observed. Thus, FRET technique combines naturally with single molecule detection methods. A good practical review of the technology and its usage can be found in Ha, T, *Single-molecule fluorescence resonance energy transfer*, METHODS 25, 78-86 (2001).

There are several parameters which are important for single molecule detection in general, and single pair FRET in particular. One is the reduction of background noise and background fluorescence. Both *in-vitro* and *in-vivo*, the molecules to be detected are surrounded by a complex molecular environment that emits radiation at any recorded frequency. The solution to this background noise involves reduction of the observed volume. This can be achieved in several ways. Confocal microscopy limits the observed volume to

the order of 10^{-15} L, which is sufficient for many applications. Total internal reflectance is an illumination mode that uses the phenomenon of evanescent wave (Toomre D, and Manstein DJ, *Lighting up the cell surface with evanescent wave microscopy*, Trends Cell Biol. 2001 Jul; 11(7): 298-303). With this illumination mode only a slab whose thickness is just about a hundred nanometers above the slide surface is illuminated. Another method that is becoming widespread is two-photon microscopy. With two-photon microscopy, the illumination radiation has approximately half the required excitation energy (i.e., half the frequency or double the wavelength). Only when the fluorophore interacts simultaneously with two photons will it be excited. This reaction requires a very high photon intensity, which occurs only in the focus of the illumination beam, thus allowing drastic reduction of the excitation volume while bringing the background fluorescence to practically zero.

Another important parameter for our application is the sampling rate, or frame rate of the system. In prokaryotes, the ribosome synthesizes polypeptides at the rate of about 20 amino acids per second. In eukaryotes the rate is about an order of magnitude lower. If the FRET signal is assumed to be "on" for about half the synthesis cycle, and if at least 4-5 samplings are required for reliable detection, then a sampling rate of about 200 frames per second is required for prokaryotes.

It is preferable that the system be able to monitor a number of active ribosomes simultaneously. A ribosome has a diameter of about 20nM, and the distance between two ribosomes (on the same mRNA strand) is on the order of 40nM. The resolution of standard optical microscopes, at their diffraction limit, is about 180nM, and for practical resolution of active PSM signals we should assume a distance at least 4 times larger. Thus, a realistic computation assumes one PSM signal per square micron. In a system with pixel size .1micron and field of 1000X1000 pixels, the field of view is 100 microns square, which typically holds 100 eukaryotic cells and can resolve hundreds and even thousands of ribosomes.

Another important point is photobleaching of the fluorophores. When a fluorescent dye is excited it is susceptible to oxidation or photobleaching. With standard fluorophores such as naturally fluorescent proteins or small organic dyes, bleaching can be minimized both by eliminating as far as possible the sample exposure to oxygen, and on the other hand employing an enzymatic oxygen scavenger system. Singlet oxygen is presumed to be the main culprit in photobleaching, and in some cases oxygen removal has a considerable effect

on reducing photobleaching (cf. T. Ha, METHODS 25, 78-86(2001)). If the system in use is two-photon microscopy, than photobleaching is reduced considerably compared to confocal microscopy, especially because of the significant, or even near complete reduction in background excitation. Another configuration that helps lengthen the signal generation time is the use of quantum dots, which are practically immune to bleaching. When quantum dots are used as donors, and if the excitation radiation is well outside the excitation spectrum of the acceptor, very long monitoring times can be expected.

Novel fluorescent technology – natural proteins, organic dyes and quantum dots

Over the last years, important advances have been made in fluorescent marker technology. First, a large variety of naturally fluorescent proteins have been found. These enable a wide variety of *in-vivo* labeling strategies (cf. Miyawaki, A., Sawano, A and Takako, K. *Lighting up cells: labeling proteins with fluorophores*. Nat Cell Biol. 2003 Sep; Suppl:S1-7. Review.). Fluorescent proteins can be found with excitation peaks from 382nm (BFP – blue fluorescent protein) to 590nm (HcRed1), and emission peaks between 448 and 618nm for these proteins, respectively. Naturally fluorescent proteins are particularly useful for *in-vivo* labeling in the form of fusion proteins. Fusion proteins are engineered proteins whose amino acid sequence includes two parts: the first part contains the sequence of the fluorescent marker protein and the second part contains the protein of interest to which the fluorescent marker is attached. Fusion proteins with naturally fluorescent proteins can be generated using the method of Baubet *et al.* (Proc. Natl Acad. Sci. USA 97:7260-5, 2000, herein incorporated by reference).

Green fluorescent protein (GFP) and its derivatives include a chromophore built of amino acids located in the center of the molecule. GFP excels in being photostable as well as having numerous variants with a choice of excitation and emission wavelengths (U.S. Patents 5,626,058 and 5,777,079; Herzenberg *et al.*, Clin Chem. 2002 Oct;48(10):1819-27; Hailey *et al.*, Methods Enzymol. 2002;351:34-49). GFP can be attached to a ribosomal protein through the method of generation of a fusion protein, by well-known recombinant techniques as explained, for example, in *Molecular Cloning, A Laboratory Manual*, Cold Spring Harbor Laboratory, Cold Spring Harbor, New York, chapter 17, 1989, herein incorporated by reference. A cell that is engineered to produce this fusion protein can produce ribosomes that include the engineered ribosomal protein as required. A

comprehensive treatment of green fluorescent protein is Chalfie, M. & Kain, S. (1998) *Green fluorescent protein: properties, applications, and protocols*, eds. Chalfie, M. & Kain, S. (Wiley-Liss, New York), herein incorporated by reference.

Another relevant technology is that of semiconductor quantum dots, which has
5 matured sufficiently to be used routinely to label biomolecules (Jovin, T.M., *Quantum dots finally come of age*, Nat Biotechnol. 2003 Jan;21(1):32-3 and references therein, Medintz, I.L. *et al.*, *Self-assembled nanoscale biosensors based on quantum dot FRET donors*, Nat Mater. 2003 Sep;2(9):630-8). Quantum dots are currently manufactured as colloidal
10 inorganic semiconductor nanocrystals consisting of a CdSe core and a ZnS cap. The absorption spectra of these dots are very wide, while the emission is very narrow (20-40nm FWHM). The emission spectrum can be controlled by the size of the dot, where larger dots emit longer wavelengths. Most importantly, quantum dots are practically immune to photobleaching, such that monitoring can optionally be performed for minutes or even hours, in contrast with traditional probes, that may bleach out after a few seconds. This is important
15 for this optional application since a protein synthesis monitoring system should be able to monitor protein production over a period of hours.

The application of quantum dots to biomolecules labeling was hampered by several technical difficulties which were recently overcome. Powerful applications of quantum dots have been recently published. In Jaiswal *et al.*, Nat. Biotechnol. 21, 47-51 (2003), HeLa
20 cells labeled by endocytosis of quantum dots coated with DHLA retained the internalized dots and continued to grow for more than a week. In Wu *et al.*, Nat. Biotechnol. 21 41-46 (2003), successful targeting of quantum dots to a cell surface receptor, cytoskeletal components and nuclear antigens were demonstrated. In Medintz, I.L. *et al.*, "*Self-assembled nanoscale biosensors based on quantum dot FRET donors*", Nat Mater. 2003 Sep;2(9):630-
25 8, a hybrid inorganic-bioreceptor sensor has been produced, where the quantum dot serves as FRET donor and an organic dye as a quencher. The use of a quantum dot as a FRET donor is an important optional application for the present invention, as discussed below.

Several techniques for *In-vivo* labeling with quantum dots have been developed, including endocytic uptake and selective labeling of cell surface proteins with quantum dots
30 conjugated to antibodies are described in (Jaiswal *et al.*, ref above). Quantum dots, individually encapsulated in phospholipid block-copolymer micelles have been injected into *Xenopus* embryo cells, and the embryo development has been followed for several days

(Dubertret *et al.*, "In-vivo imaging of quantum dots encapsulated in phospholipid micelles", Science. 2002 Nov 29;298(5599):1759-62).

Quantum dots are commercially available from Quantum Dot Corporation, Hayward, Ca. These are available ready for use in biological assays, with several surface treatments –
5 biotinylated, conjugated with streptavidin, or conjugated to Protein A. Several spectral profiles are offered for each product. Detailed protocols are available from www.qdots.com.

Last, new techniques of *in-vivo* labeling allow the use not only of naturally fluorescent proteins, but also of quantum dots and organic dyes (cf . Miyawaki *et al.*, reference above) to study parameters of live cells. One example of a novel technique for
10 labeling proteins with small organic fluorophores within live cells uses bi-arsenic fluorophore labeling of proteins that have been genetically altered to contain tetra-cysteine motifs (Griffin *et al.*, *specific covalent labeling of recombinant protein molecules inside live cells*", Science 281, 269-272 (1998)). The protein to be labeled is genetically fused to a short peptide containing a CCXXCC motif. The fluorescent label, FlAsH, is a derivative of
15 fluorescein that contains two arsenoxide groups. The FlAsH label is membrane-permeant and non-fluorescent, acquiring fluorescence only on binding to the CCXXCC motif.

There are numerous suppliers, catalogs and on-line resources that help in selection of fluorescent probes, FRET pairs, and attachment reagents. Some well known suppliers are Molecular probes (<http://www.probes.com/>, handbook of fluorescent probes
20 <http://www.probes.com/handbook/>), Bio-Rad corporation (<http://fluorescence.bio-rad.com/>) and Pierce (<http://www.piercenet.com/products/browse.cfm?fldID=1CC1AF24-9D9B-4D21-B850-688931CF7E3B>).

Numerous other methods exist for fluorescent labeling or dyeing a protein for fluorescent applications, as explained, for example in Allan, V.J. (ed), *Protein Localization
25 by Fluorescence Microscopy, A Practical Approach*, Oxford University Press, herein incorporated by reference.

Cell-free translation systems

30 Cell free translation systems are well known. Recently a synthetic system, built entirely from purified recombinant factors, and that has a high protein synthesis yield, was described (Shimizu *et al.*, *Cell-free translation reconstituted with purified components*. Nat Biotechnol. 2001 Aug;19(8):751-5). Kits and detailed instructions can be obtained from

vendors such as Promega (Madison, WI). These systems are used for several applications, such as ORF validation and functional analysis of gene products. The systems contain ribosome-rich media with the required tRNAs and amino acids, and little or no mRNA. When mRNA is introduced, the ribosomes begin translation and proteins are produced.

5 Often the proteins are produced radiolabeled. This enables the researcher to verify that the required proteins were in fact produced. The optional, exemplary system disclosed here is easier to assemble *in-vitro* than *in-vivo*, since labeling techniques are more readily available and easier to implement.

Translation of *in-vitro* transcribed mRNAs: *In-vitro* translation can be performed
10 using kits such as the nuclease-treated rabbit reticulocyte lysate available from Promega, (Madison, WI). Before *in-vitro* translation, cellular mRNAs are heated at 67 °C for 10 min to unfold secondary structures that would eventually affect the efficiency of mRNA translation. Reactions are then assembled as recommended by the supplier in the presence of 20 mCi of [35^S]methionine (ICN Biochemicals). Protein synthesis occurs during incubation at 30° C.
15 Customarily, the resulting proteins are purified and analyzed by radiolabeling. The procedure requires centrifugation, rinsing and immune-precipitation followed by separation on SDS-polyacrylamide gels. Following electrophoresis, gels are exposed to film or Phosphor B1 screens, and the bands corresponding to the synthesized protein verified. For PSM applications, radiolabeling of protein products may optionally be performed but is not
20 required.

With the present invention, cell-free translation systems could optionally produce one protein or many proteins, and their identification and production rates could be measured, controlled, and optimized in real time. This can lead to new protein production methods that are easier to control than the customary methods of bio-production in reactors with bacteria,
25 yeast or CHO-cells, for example. Since the *in-vitro* translation system is fully controllable, and since it also allows co- and post-translational modifications, this method is an attractive alternative to current technologies.

When single molecule detection is required in *in-vitro* translation systems, the molecules need to be immobilized. There are several approaches to immobilization of
30 biomolecules. Biomolecules can be attached specifically or non-specifically, and in either case, either ribosomes or mRNA templates can be immobilized.

For non-specific immobilization, DNA or RNA can be attached to a charged surface such as an aminopropylsilane-coated surface via electrostatic interaction, as described in 8. Ha, T. *et al.*, (1996) *Proc. Natl. Acad. Sci. USA* 93, 6264–6268. Even though this method avoids DNA aggregation and works in water, this immobilization method may interfere with
5 the properties or activity of the ribosome.

Another nonspecific immobilization method successfully used for single-molecule fluorescence study is trapping molecules inside polyacrylamide pores (Dickson, R. M., *et al.*, (1996) *Science* 274, 966–969) or agarose gel (Lu, H. P., *et al.*, (1998) *Science* 282, 1877–1882., Dickson, R. M., *et al.*, (1997) *Nature* 388, 355–358.). While gel immobilization has
10 the merit of not requiring any special modification of the biomolecule, it has some disadvantages. First, the concentration of other small molecules such as enzyme substrates and ions is difficult to change in a short time. Sudden changes in the buffer conditions are necessary for a certain type of single-molecule studies. Second, because of limited molecular diffusion, it is not easy to study interactions between macromolecules in gel.

Specific immobilization requires a well-defined modification of the biological
15 molecule. For instance, a biotin or a digoxigenin can be attached to an mRNA, rRNA or ribosomal protein, to immobilize them to streptavidin- or antidigoxigenin-coated surfaces respectively. Alternatively, histidine tags that are typically introduced to help the purification of recombination proteins can be used to immobilize a ribosomal protein on a Ni-NTA-
20 coated surface. A detailed procedure for preparing a mini-flow cell to immobilize biotinylated nucleic acids is described in Ha, T., *Methods* 25, 78-86 (2001).

A surface can be densely coated by polyethylene glycol (PEG). PEG is known to reject protein adsorption to a surface if it forms a dense coating. Bifunctional PEG can be used immobilize nucleic acids specifically to a surface while rejecting protein adsorption.
25 mRNA can be optionally immobilized on a polyethylene glycol (PEG) coated surface with biotin-streptavidin linker, and the ribosomes allowed to process the immobilized mRNA. The mRNA preferably features 3'-end biotin labeling. Since protein synthesis may not end normally because of the linked 3' end, it is advisable to ensure that the template mRNA continues for at least 20 codons beyond the stop codon. In another approach, a ribosomal
30 protein can be labeled with biotin and immobilized on a fused glass slide. The other ribosomal components can then be reconstituted around the immobilized protein.

Ribosomal complexes can also be bound to a mica surface, which is transparent and flat on a molecular size scale. Ribosomes, either labeled or unlabeled, undergo binding to mica in a few seconds, allowing the detection of single fluorescence images in aqueous buffer. A large excess of ribosomes and a short incubation period are employed for single molecule
5 detection. The mica-bound ribosomes retain their activities, as shown in Sytnik et al., *J. Mol. Biol.* (1999), 285, 49-54, where detailed protocols are provided. Preparation of the mica cells and adsorption of ribosomes to these cells is also described in Vanzi *et al.*, *Protein synthesis by single ribosomes*, *RNA* (2003), 9:1174–1179.

10 LIST OF ABBREVIATIONS

ADME-TOX: A set of parameters relevant to drug candidates that should be measured prior to clinical trials (Absorption, Distribution, Metabolism, and Excretion) and TOX (Toxicity)

APD: Avalanche photodiode, a sensitive detector of faint optical energy.

15 CCD: Charge coupled device, a photo sensitive semiconductor device usually arranged as a one- or two-dimensional array of photo sensitive cells.

CHO: Chinese hamster ovary cell line.

CSOM: Confocal scanning optical microscope.

FRET: Fluorescence resonance energy transfer. A method by which molecular distances of the order of few nanometers can be determined using appropriate fluorophores.

20 FWHM: Full width half maximum, a measure of signal resolution in spectrometry.

GPCR: Cell surface receptors that are coupled to heterotrimeric G-proteins (GTP-binding proteins).

HTS: High throughput screening, a method used in drug discovery by which a large library of chemical compounds is assayed for binding to a specific receptor.

25 ICAT: a method of sample tagging that allows relative quantitation of proteins in two samples using LC-MS-MS.

LC-MS: a mass spectrometer that is directly coupled to a liquid chromatography column, and where ionization commonly is achieved with the electrospray method.

30 LC-MS-MS: a mass spectrometer of the LC-MS type where ions are further fragmented and the mass spectrum of the fragments is measured. Often used to identify sequences of tryptic peptides.

MALDI-TOF: mass spectrometer that ionizes the sample with the technique of matrix-assisted laser desorption ionization, and measures masses using a time-of-flight mass analyzer.

NA: numerical aperture (of a lens).

5 ORF: Open reading frame. A putative protein-encoding gene.

PCR: Polymerase chain reaction, a method for *in-vitro* amplification of DNA.

PEG: polyethylene glycol, a surface treatment agent that aids in immobilization of biomolecules for optical analysis.

PMT: photomultiplier tube, a sensitive photodetector.

10 PSM: Protein synthesis monitoring, an acronym for at least some aspects of the present invention.

tRNA: transfer RNA, the adaptor molecule that delivers amino acids to the ribosome.

mRNA: messenger RNA, the template by which proteins are synthesized.

rRNA: ribosomal RNA, one of the RNA strands that are part of the ribosome.

15 SHIM: Second harmonic imaging microscopy.

TIR: Total internal reflection, a microscopy illumination method that illuminates a very volume at the interface of two materials with different refractive indices.

TIR-FM: total internal reflection fluorescent microscopy.

TPE: two photon excitation, an illumination method for special microscopy applications.

20 TPM: Two Photon microscopy, a microscopy system that uses TPE illumination.

Y2H: A method for detecting protein-protein interaction *in-vivo* in *Saccharomyces cerevisiae*.

BRIEF DESCRIPTION OF THE DRAWINGS

25 The invention is herein described, by way of example only, with reference to the accompanying drawings. With specific reference now to the drawings in detail, it is stressed that the particulars shown are by way of example and for purposes of illustrative discussion of the preferred embodiments of the present invention only, and are presented in the cause of providing what is believed to be the most useful and readily understood description of the principles and conceptual aspects of the invention. In this regard, no attempt is made to
30 show structural details of the invention in more detail than is necessary for a fundamental

understanding of the invention, the description taken with the drawings making apparent to those skilled in the art how the several forms of the invention may be embodied in practice.

In the drawings:

FIGURES 1A and 1B describe the properties of a FRET pair and the dependence of the FRET effect on pair distance.

FIGURE 2A describes the tRNA molecule.

FIGURE 2B describes the basic structure of a ribosome and the elongation cycle.

FIGURES 3A-3C describe the stages of the elongation cycle.

FIGURE 4 describes the embodiment of the R-T tag strategy.

FIGURE 5 describes the embodiment of the R-A tag strategy.

FIGURES 6A-6D describe the embodiment of the R-R tag strategy.

FIGURE 7 shows the principle of total internal reflection (TIR) illumination.

FIGURE 8 describes the general setup of a PSM system.

FIGURE 9 describes the stages of the signal processing channel.

FIGURE 10 describes a confocal microscopy setup for PSM.

FIGURE 11 describes confocal PSM optical setup at the sample scale.

FIGURE 12 describes a wide-field TIR microscopy setup for PSM.

FIGURE 13 describes a two-photon microscopy setup for PSM.

FIGURES 14A-14D describe a simulation of an illustrative method for signal processing according to the present invention.

FIGURE 15 shows an optional, illustrative strategy suitable for screening of a chemical compound library with the system and method disclosed herein.

DETAILED DESCRIPTION OF SEVERAL EMBODIMENTS

The present invention is of a system and method for monitoring protein synthesis in a protein synthesis system, by using a marker for protein synthesis in the system, which preferably causes electromagnetic radiation to be emitted. The protein synthesis system may optionally comprise a single ribosome, or alternatively a plurality of ribosomes. The marker optionally comprises at least one photo-active component.

The emitted electromagnetic radiation is then detected and can be analyzed to monitor protein synthesis. The present invention may optionally be performed qualitatively, but is preferably performed quantitatively. As used herein, "monitoring" may also optionally

include at least the initial detection of a protein synthetic act or process, such as an interaction between a tRNA and a ribosome for example, preferably in real time. Optionally and preferably, monitoring includes identification of the tRNA or tRNA species, amino acid or amino acid species, codon or codon species that are being processed. Preferably, monitoring includes detecting a plurality of such synthetic acts, such as a plurality of interactions between a ribosome and a plurality of different tRNA molecules for example. Monitoring may also optionally and more preferably include identifying the protein being synthesized. Such monitoring is optionally and preferably performed with a protein synthesis system, optionally and more preferably including a single ribosome or a plurality of ribosomes, optionally with tRNA or tRNA species and/or other protein synthetic components as required, optionally *in vivo* or *in vitro*.

The marker preferably enables the present invention to detect which tRNA is currently being processed by a ribosome, which mRNA codon is being read, or which amino acid is currently being added to the nascent protein. This signal can optionally and preferably be captured and analyzed in seconds to reveal the protein's identity. The procedure can optionally be performed simultaneously for hundreds of single ribosomes, optionally *in vitro* or *in vivo* and so provide, for the first time in biology, a tool for dynamic monitoring of protein synthesis.

Optionally, as described in greater detail below, the present invention may be implemented with a cell that is stably engineered, for example through genetic engineering, to form a stable cell culture and/or cell line. Alternatively or additionally, the cell may optionally be transiently altered or engineered; optionally a combination of these techniques may be employed, for a single cell or a plurality of cells.

Optionally and preferably, the present invention is used for performing a screening assay by detecting or monitoring the protein synthetic act. Optionally, the screening assay is for detecting a pathological condition in a subject, such as cancer for example. The present invention may also optionally be used for pathway elucidation by detecting or monitoring the protein synthetic act. The present invention may also optionally be used for cell state analysis by detecting or monitoring protein synthetic act, for example by identifying the synthesis of proteins related to apoptosis, heat shock, DNA damage repair, budding, or any other cell state.

Illustrative, optional methods for monitoring of protein synthesis are now described in detail below. The method will be described in several variants and several applications by way of an example, and it should be recognized that the illustrated embodiments should not be taken as a limitation on the scope of the disclosure. The following sections describe various aspects and details of the new invention.

SECTION I: ILLUSTRATIVE EMBODIMENTS OF THE PRESENT INVENTION

DD1 Strategies for synthesis monitoring (R-T, R-A, R-R, and multicolor)

10 **Overview**

An optional, exemplary but preferred method of the present invention is now described for synthesis monitoring. The ribosome of a live bacterium, cell, or an *in-vitro* translation mechanism is tagged with a donor fluorophore. One or more types of acceptor fluorophores are placed on some of the tRNAs and/or on some of the amino acids and/or on another part of the ribosome. As the ribosome goes through the elongation cycle, a FRET signal is generated when labeled tRNAs, labeled amino acids or appropriate codons are processed. Since only some and not all species of tRNA or amino acids or codons are designed to generate a signal, the resulting signal is a characteristic of the protein being translated, and so, with an appropriate method of signal analysis, this protein may optionally be identified.

One exemplary flow of operation is now described. An optical apparatus monitors a marked protein synthesis system (a system featuring at least one marker according to the present invention), optionally by directing electromagnetic radiation of the required wavelength and energy onto the marked system, thereby exciting the donor fluorophores. The acceptor fluorophores on the tRNAs and/or amino acids and/or on the ribosome, whether engineered or natural, respond to this energy with the FRET effect whenever donor and acceptor are in sufficient proximity, indicating the progress of the elongation cycle of said synthesis system. Fluorescence radiation emitted from the acceptor fluorophores is detected by the optical apparatus and the event is recorded by a computerized analysis unit. Since only some of the elongation cycles but not all of them generate a signal, the resulting sequence of detection events is a characteristic of the protein being synthesized. In computer science terminology this signal sequence may optionally be described as a bit stream with zeroes and ones. The stream contains some uncertainty as to the number of bits in each field,

as well as other elements of uncertainty. The signal is subsequently used to interrogate a database of signals computed from a relevant database of protein sequences. The method disclosed herein describes how to use this signal to identify the protein that is most likely to have produced the signal.

5 The method is preferably able to consider the precise nature of the uncertainty in the detected signal sequence, in order to provide a scoring function that is able to compute the measure of likelihood, for each protein in the database, that this protein species is the one whose synthesis produced the signal sequence that was detected.

10 There are a number of optional basic strategies for PSM labeling (for adding a marker to the protein synthesis system, optionally through covalent or non-covalent binding, for example to a tRNA and/or ribosome or portion thereof), a few examples of which are described below.

15 **Ribosome-tRNA (R-T) labeling**

 This optional, exemplary labeling strategy calls for a donor label on the ribosome and an acceptor label on tRNA, or vice versa. R-T tagging or labeling may optionally include a fluorescent labeling method in which the ribosome and tRNA form a FRET pair and/or other type of donor/acceptor pair and/or fluorescent/quencher pair. Figure 4 shows a specific
20 example of this strategy.

 In this optional embodiment of the present invention, R-T tagging involves placing a donor on the ribosome and an acceptor on some of the tRNAs. Methods of tagging tRNAs and ribosomes are discussed below. The tag can be placed either near the A, the P, or the E site. In one preferable embodiment a ribosomal locus near the E site is tagged. This ensures
25 that the tRNA is identified after the proofreading stage. In one preferable embodiment ribosomal proteins are tagged. Several ribosomal proteins are known to be near the E site, such as ribosomal proteins L1, S1 and S21. Experiments have shown that these proteins can be efficiently tagged while retaining ribosome functionality. Such experiments are described, for example, in Mascarenhas *et al.*, *Specific polar localization of ribosomes in Bacillus subtilis depends on active transcription*. EMBO Rep. 2001 Aug; 2(8):685-9, in which
30 ribosomal protein L1 was labeled with blue fluorescent protein (BFP) and proven to retain its functionality; and in Odom *et al.*, "Relaxation time, interthiol distance, and mechanism of

action of ribosomal protein S1", Archiv. Biochem. Biophys. 1984, 230(1) 178-193, in which ribosomal protein S1 was labeled through its two cysteines.

Figure 4 shows one exemplary embodiment of the R-T tagging strategy. Ribosome large subunit 160 and small subunit 164 are attached to an mRNA 162 being processed. tRNA 170 (with amino acid 180) is in A site 171, tRNA 172 (with amino acid 182) in P site 173, tRNA 174 in E site 175. tRNA 176 has just been ejected out of the E site and tRNA 178 is already free of the ribosomal-mRNA complex. The growing polypeptide chain 184 is also shown. Donor fluorophore 190 is located preferably and optionally on ribosomal protein L1, which is attached to large ribosome subunit 160, just outside the mRNA exit channel (not shown), in proximity to the E site. tRNA 176 in this Figure is labeled with a fluorescent label 192 and therefore is in close proximity to the donor fluorophore 190. The donor fluorophore emission spectrum overlaps the excitation spectrum of acceptor fluorophore 192. Radiation energy 194 is made to impinge on donor fluorophore 190 and excite it, causing part of the energy to transfer to acceptor fluorophore 192, exciting it and causing emission of FRET signal 196 of a lower energy and therefore higher wavelength. When tRNA 192 is not of a tRNA species that has been labeled, a FRET signal is not emitted. Thus, as the ribosome processes the mRNA, an on-off signal is detected by the system that corresponds to the tRNA labeling scheme being used and therefore characterizing the protein being synthesized, allowing the identification of the protein being synthesized.

R-A labeling

R-A tagging or labeling is another optional embodiment of the present invention, in which the ribosome and an amino acid form a FRET pair and/or other donor/acceptor pair and/or fluorescent/quencher pair. In another exemplary, optional embodiment of the present invention, the donor tag is placed near the peptide exit channel, and so is able to excite the acceptor fluorophores on the amino acids, either natural or engineered. In this embodiment, the detected FRET signal correlates with the amino acid sequence of the protein being synthesized; however, the proteins include labeled amino acids and are therefore no longer completely natural, a fact which may influence the functioning of the cellular mechanism.

In Figure 5 an example of this type of embodiment is depicted. Ribosome small subunit 200 and large subunit 202 are attached to mRNA 204 being processed. tRNA 206 is docked in the A site and carries amino acid 220. tRNA 208 is docked in P site and carries

amino acid 222. tRNA 210 is docked in the E site and its amino acid has already been removed. Donor fluorophore 226 is attached to the ribosome in a location near the exit location of the peptide channel (not shown). Donor fluorophore 226 is illuminated with electromagnetic radiation 230 of a frequency compatible with its excitation frequency.

5 Emission frequency of donor fluorophore 226 overlaps the excitation frequency of acceptor fluorophore 228. Acceptor fluorophore can be either natural, as in the amino acids tyrosine, tryptophan and phenylalanine for example, or else can be artificially labeled as explained below. In any case, if the amino acid 224 is appropriately labeled with acceptor fluorophore 228, then a FRET 232 signal is generated when acceptor fluorophore 228 passes sufficiently

10 close to donor fluorophore 226. When unlabeled amino acids are in this position, a FRET signal is not generated. Thus, as the ribosome synthesizes the protein, an on-off signal is generated that is characteristic of the protein being synthesized, allowing it to be identified.

R-R labeling

15 R-R tagging or labeling is another optional embodiment of the present invention in which two locations on the ribosome, optionally covalently bound or non-covalently associated moieties, form a FRET pair and/or other donor/acceptor pair, and/or fluorescent/quencher pair.

In another exemplary, optional embodiment of the present invention, both donor and

20 acceptor tags are attached to the ribosome; the combination of both tags may optionally be described as a marker for the present invention. One tag ("base") is preferably located on a fixed part of the ribosome, which makes it static. The other ("lever") is preferably an appendage engineered to be attached to the ribosome, covalently or non-covalently, and is capable of moving in one prescribed direction – towards or away from the location of the

25 mRNA as it exits the ribosome. In one optional embodiment, the lever mimics a tRNA molecule in order to recognize exiting mRNA codons. The lever is preferably constructed to bind weakly to a specific nucleotide triplet or pair, as in the case of codon-anticodon recognition rules. If, for example, the lever is designed to recognize the nucleotide pair GC, whenever the mRNA sequence contains a GC in the appropriate position, the lever goes

30 "down" and binds to GC, preferably causing a fluorescent signal to be generated or quenched (or optionally a combination, if a plurality of fluorescent moieties is present). For other pairs, the lever stays "up" and this signal is not generated or quenched (or the

combination is not generated). The FRET or other type of signal thus marks the advance of the mRNA with a bimodal response. This embodiment has the important benefits of leaving the translation mechanism almost entirely natural – tRNAs and amino acids are completely natural, only an external part of the ribosome has been tampered with.

5 Illustrative diagrams of this exemplary embodiment are shown in Figures 6A-6D. The lever is a preferably a modified tRNA molecule, with a “codon loop” and a relatively long and rigid arm, connected to a “hinge”. This can be engineered to stem out of a single strand rRNA loop. The ribosomal RNA has numerous stretches of single strands, extending from a few bases to a few dozen bases. These single strand loops are convenient for placing
10 an extension that has the required biochemical and physical characteristics. The pseudo-anticodon part of the lever is constructed to bind weakly to a specific nucleotide pair, such as GC in the example. In Figure 6A the mechanism is shown in the “non-recognition” configuration. **100** and **102** are the small and large ribosome subunits, **110**, **111** and **112** are the A, P and E sites respectively. Only the A site **110** and P site **111** are occupied in this
15 diagram.

A tRNA-like lever **120**, connected in this illustrative example to large ribosomal subunit **102**, does not bind (binding taken here to signify at least the creation of Watson-Crick pairs) to the nucleotides on mRNA **104**, which passes between large subunit **102** and small subunit **100**. This lack of binding is because the corresponding bases on the mRNA
20 **104** and pseudo-anticodon **120** are not complementary pairs (in the Watson-Crick sense). Therefore lever **120** stays relatively far removed from an acceptor fluorophore **152**. Lever **120** carries a donor fluorophore **151**, while the acceptor fluorophore **152** is attached at an appropriate location to the ribosome. When lever **120** remains in the “far” position, a small or null FRET signal is generated.

25 In Figure 6B the mechanism is shown in a “recognition” configuration, where the pseudo-anticodon on tRNA-like lever **120** does match the nucleotides on mRNA **104**, in the sense of Watson-Crick pairing. Therefore lever **120** moves relatively near to mRNA **104**, causing donor fluorophore **151** and acceptor fluorophore **152** to come into close proximity and to emit a large FRET signal. The FRET signal thus marks the advance of the mRNA
30 with a bimodal response – for example, detection of a large signal versus small signal. Thus, as the ribosome processes the mRNA, an on-off signal is generated that is characteristic of the protein being synthesized, allowing it to be identified.

In Figures 6C and 6D this mechanism is shown in greater detail. Ribosome 122 has protruding chains 126 and 128 (shown in grey). The mRNA being translated 124 is shown with nucleotides spaced on it. Static label 138 is attached to a location on one of these protruding chains. Artificially engineered RNA chain ("lever") 130 (shown in black) is attached at point 132 to form a movable hinge. The main part of RNA chain 130 has a helical structure and therefore is physically rigid. The part farthest away from hinge 132 has an anticodon nucleotide sequence 134. On the chain 130 a fluorescent label 136 is attached. Figure 6C shows the lever in recognition configuration, where the anticodon 134 recognizes a codon on mRNA 124. In this case the lever assumes a position where the fluorescent labels 136 and 138 are in close proximity, allowing a FRET signal to be emitted. In Figure 6D, the lever is in a non-recognition configuration, where the anticodon 134 does not recognize the codon on mRNA 124. In this case the lever assumes a position where the fluorescent labels 136 and 138 are relatively far apart, and a FRET signal is not emitted, or else a much smaller FRET signal is emitted than in a recognition configuration.

Multicolor labeling

In the preceding examples it was assumed that the labeling was of the "on/off" kind, that is, one type of label was either used or not used. Optionally and preferably, some preferred embodiments of the present invention use more than one type of label. For example, in the R-T labeling strategy, if each type of tRNA could be labeled with its own specific color, the system would have been simpler since database interrogation would have become a matter of a trivial search procedure and, indeed, *de-novo* protein sequencing would have been possible *in-vivo*. Again, such a label optionally forms part or all of the marker according to the present invention. Even if this optional scheme is difficult to achieve, labeling the tRNA species with more than one color increases the amount of information available. For example, if 10 tRNA species are labeled with two label types (5 with each) rather than one, an increase of $\binom{10}{5}=252$ fold in the amount of information is obtained. In fact, with some of the labeling methods this becomes possible. For example, when acceptor fluorophore is a quantum dot, then its excitation spectrum is very wide (see above), while the emission spectra is very narrow and can be distinguished easily. In such a case one donor fluorophore can excite several acceptors, resulting in additional sequence information.

Additional PSM strategies

In one preferred embodiment, a plurality or even all tRNAs, amino acids or codons are labeled, and not just a part of them. When this is done with one type of label, it is not possible to identify the protein being synthesized. However, this technique is useful for measuring synthesis rates, on/off FRET times, and for system calibration. When the labeling is done with several types of fluorophores, two, three or more, a large increase in the amount of information and confidence of the resulting identification is obtained when all items are labeled.

In one preferred embodiment, a quenching strategy is used instead of FRET, as noted previously. In this approach, instead of a fluorescent donor and acceptor, there is a fluorescent donor and an acceptor quencher that captures the donor energy without emission. In this strategy, donor fluorescence is detected as long as the quencher is not sufficiently near to the donor. In PSM, this would generate a signal of donor fluorescence intermitted by periods of quenching.

In another preferred embodiment, a combination of methods can be used. For example, some tRNAs may be labeled for R-T tagging strategy, as well as one or more amino acids that are labeled for R-A strategy. The ribosome is labeled in a way that allows both methods to be used. Preferably, the amino acids are labeled with fluorescent labels that are distinct from tRNA labels. The signal analysis system accepts both signals and uses both in order to identify more confidently the protein being synthesized. It is obvious to anyone skilled in the art of single molecule detection and analysis that this is just one example of a wide variety of methods that can be derived from this particular example.

In one optional but preferred embodiment of the present invention, the natural fluorescence of tRNAs and/or amino acids is utilized. In another optional embodiment of the present invention, a fluorophore is attached to some tRNAs and/or amino acids. It is clear to anyone skilled in this art that the donor and acceptor configurations could be switched. It is also clear to anyone skilled in the art that the embodiments described above are not mutually exclusive and any combination thereof can be used, which is another optional embodiment

of the present invention. For example, the natural fluorescence of some amino acids together with artificially labeled tRNA species can be used in a combination system.

DD2 Fluorescent labeling of ribosome, proteins and tRNA

5 Ribosome labeling.

A large body of research details fluorescent labeling techniques of ribosomes; such labeling may optionally be used with the present invention as a marker or a portion thereof. These include *in-vitro* and *in-vivo* labeling, labeling with naturally fluorescent proteins and with organic dyes. Other published techniques that are relevant include labeling with
10 semiconductor quantum dots. Labeling strategies included labeling ribosomal proteins such as ribosomal proteins L1, S1, S21 and others; In addition, 3' and 5' ends of 5S, 16S and 23S rRNA have been labeled (Robbins and Hardesty, *Comparison of ribosomal entry and acceptor transfer ribonucleic acid binding sites on Escherichia coli 70S ribosomes. Fluorescence energy transfer measurements from Phe-tRNA^{Phe} to the 3' end of 16S*
15 *ribonucleic acid*. Biochemistry. 1983 Nov 22; 22(24):5675-9.).

For *in-vitro* labeling, there are several strategies. Organic dyes can be used to label ribosomal proteins using standard protein labeling techniques. Suppliers of these dyes publish detailed protocols describing their use. General procedures label proteins through
20 their amino groups (lysine). Other procedures target cysteines which are sometimes available for precisely located labeling. In this way, ribosomal proteins S1 and S8 were labeled by coumarin (Bakin *et al.*, *Spatial organization of template polynucleotides on the ribosome determined by fluorescence methods*. J Mol Biol. 1991 Sep 20; 221(2):441-53), and ribosomal proteins were tagged with fluorescein attached to a cysteine residue (Odom *et al.*, *Movement of tRNA but not the nascent peptide during peptide bond formation on ribosomes*.
25 Biochemistry. 1990 Dec 4;29(48):10734-44).

A novel labeling strategy uses quantum dots, which are commercially available pre-conjugated with biotin or streptavidin. In such cases, proteins can be labeled with biotin, so the streptavidin conjugated qdots (commercially available as QdotTM525/ QdotTM 565/
30 QdotTM 605/ QdotTM 655 streptavidin conjugated quantum dots, from Quantum Dot Corporation, Hayward, Ca, USA; the numbers relate to maximal emission wavelength, nm) bind specifically to them. One useful method of generating a biotin-labeled protein involves creating a fusion protein between the protein of choice and biotin carboxyl carrier protein

(BCCP). In the fusion protein, the original protein sequence is fused optionally to the last 87 (or 110) codons of the E. coli BCCP. When the fusion protein is translated, it has the biotin tag attached to it and binds specifically to streptavidin (cf. Surrey *et al.*, *Proc. Natl. Acad. Sci. USA*, Vol. 95, pp. 4293–4298, April 1998). This method is also useful *in-vivo*, since
5 both organic dyes and quantum dots can be engineered to be attached to streptavidin and have membrane permeable characteristics (see, for example, Miyawaki, *et al.*, *Nat Cell Biol.* 2003 Sep; Suppl:S1-7. Review; and Akerman *et al.*, *PNAS*, 99:12617-12621, 2002.)

Another method that is useful for *in-vivo* labeling of ribosomal proteins is the well known strategy of fusing the protein of choice with a naturally fluorescent protein, such as
10 green fluorescent protein, yellow/cyan/blue fluorescent proteins or any other naturally fluorescent protein. An example where L1 was labeled by fusing it with a naturally fluorescent protein is described in (Mascarenhas *et al.*, *Specific polar localization of ribosomes in Bacillus subtilis depends on active transcription.* EMBO Rep. 2001 Aug; 2(8):685-9). Yet another novel method of *in-vivo* labeling involves the rare sequence
15 CCXXCC (C= cystein). The protein to be labeled is genetically fused to a short peptide containing a CCXXCC motif. The fluorescent label, FLAsH, a derivative of fluorescein that contains two arsenoxide groups, is membrane-permeant and non-fluorescent, acquiring fluorescence only on binding to the CCXXCC motif.

Numerous additional strategies for ribosome labeling were tested and others are
20 clearly possible.

tRNA labeling

Labeling a tRNA molecule is sensitive, since the molecule is small, and since it interacts in intricate ways with the aminoacyl synthetases on the one hand and with the
25 ribosomal machinery on the other. As a tRNA molecule docks onto (binds to) the ribosome-mRNA complex, it is bound with elongation factor EF-TU and a GTP molecule. Tagging should also be compatible with this complex. Further, tRNA tag should have a high binding rate, so that preferably above 90% of the labeled tRNA species is actually labeled.

Experiments have shown that tRNA molecules can be tagged while retaining their
30 interaction with the aminoacyl synthetases as well as retaining their functionality with the ribosome. tRNAs have been tagged with fluorescein (Watson *et al.*, *Macromolecular arrangement in the aminoacyl-tRNA. elongation factor Tu.GTP ternary complex.* A

fluorescence energy transfer study, Biochemistry. 1995 Jun 20; 34(24):7904-12; Plumbridge *et al.*, *Characterisation of a new, fully active fluorescent derivative of E. coli tRNA Phe*. Nucleic Acids Res. 1980 Feb 25; 8(4):827-43), tetra methyl rhodamine (Jia *et al.*, *Nonexponential kinetics of a single tRNAPhe molecule under physiological conditions*. Proc Natl Acad Sci U S A. 1997 Jul 22;94(15):7932-6), with the dye IAEDANS (5-(((2-iodoacetyl)amino)ethyl)amino) naphthalene-1-sulfonic acid (1,5-IAEDANS)) (Johnson *et al.*, *Distance moved by transfer RNA during translocation from the A site to the P site on the ribosome*, J. Mol. Biol. (1982) 156, 113-140), with proflavine and ethidium bromide (Wintermeyer and Zachau, *Replacement of Y base, dihydrouracil, and 7-methylguanine in tRNA by artificial odd bases*. FEBS Lett. 1971 Nov 1; 18(2):214-218). Numerous other labeling strategies have been studied.

For the present invention, some optional but preferred embodiments include but are not limited to labeling the tRNA with small organic dyes attached to the "shoulder" region of the tRNA, such as in positions 8 and 47 of E.Coli tRNAs which have been often used for this purpose. Note that both the anticodon region and the amino acid carrying region are sensitive, both in charging and in discharging. The dyes with which most experience has been gained are FITC and TMR. Detailed protocols for tRNA labeling with these dyes are presented below.

In numerous published experiments E.Coli tRNA^{Phe} has been labeled by attaching a small organic dye either to the 4-thiouridine at position 8, where the sulfur atom offers the required reactive handle, or to the X-base (3-(3-amino-3-carboxypropyl)uridine) at position 47, which has a primary reactive amine group coupled to the ribonucleic base by an aliphatic handle. Out of the 45 E.Coli tRNA species, 21 species have 4-thiouridine at position 8, and 7 have an X-base at position 47. Thus, ample opportunities for tRNA tagging strategies are possible. The list of E.Coli tRNAs with these special bases at positions 8 and 47 is shown in the table below. Also shown are the amino acids carried by the tRNA molecule and the 3 base anticodon sequences. The legend for the anticodon base symbols are as follows:

U-uridine, C-cytidine, A-adenosine, G-guanosine, T-thymine, H-unknown modified adenosine, I-inosine, M-N4-acetylcytidine, Q-queuosine, 4- 4-thiouridine, V-uridine 5-oxyacetic acid, X-3-(3-amino-3-carboxypropyl) uridine.

Table 1: tRNA amino acids

Amino acid	Anticodon sequence	Base at position 8	Amino acid	Anticodon sequence	Base at position 47
Ala	VGC	4	Phe	GAA	X
Cys	GCA	4	Ile	GAU	X
Asp	QUC	4	Ile	3AU	X
Phe	GAA	4	Lys	SUU	X
Gly	CCC	4	Met	MAU	X
His	QUG	4	Arg	ICG	X
Ile	3AU	4	Val	GAC	X
Leu	HAA	4			
Met	MAU	4			
Asn	QUU	4			
Gln	CUG	4			
Gln	NUG	4			
Arg	ICG	4			
Ser	GCU	4			
Ser	GGA	4			
Ser	VGA	4			
Val	GAC	4			
Val	VAC	4			
Trp	CCA	4			
Ile	CAU	4			
Tyr	QUA	4			

A complete database of tRNA sequences can be found in <http://www.uni-bayreuth.de/departments/biochemie/trna/>. A database of known RNA modifications can be found in <http://medstat.med.utah.edu/RNAmods/>, both of which are hereby incorporated by reference as if fully set forth herein.

Another preferred and optional embodiment relies on the natural fluorescence of some tRNA species. For example, E.Coli tRNA^{Phe} contains the highly modified Y base (wybutosine) in position 37 (Langlois, R., Kim, SH and CRA Cantor. *A Comparison of the*

Fluorescence of the Y Base of Yeast tRNA Phe in Solution and in Crystals, 1975, Biochemistry 14: 2554-2558; Huang, K.H. and Cantor, C.R., *Studies of 30 S Escherichia Coli Ribosome Reassembly Using Individual Proteins Labeled with an Environmentally Sensitive Fluorescent Probe*, 1975, J. Mol. Biology 97, 423-441). In this particular
 5 embodiment, only the donor fluorophores need to be specially engineered onto the ribosome. However, this strategy has the disadvantage that the natural fluorescence of tRNA molecules is weaker than that of other specific labels.

AA labeling

10

There are three general approaches for fluorescent labeling of amino acids. The first is to rely on the natural fluorescence of tryptophan, tyrosine and phenylalanine. Tryptophan and tyrosine are highly fluorescent and can be used without modifications. Phenylalanine is slightly less so. The fluorescence properties of these amino acids are summarized in the table
 15 below.

Table 2: fluorescent properties of some amino acids

amino acid	Lifetime (Nanoseconds)	Excitation		Emission	
		Wavelength	Molar absorptivity	Wavelength	Quantum yield
Tryptophan	2.6	280	5,600	348	0.20
Tyrosine	3.6	274	1,400	303	0.14
Phenylalanine	6.4	257	200	282	0.04

The use of naturally fluorescent biomolecules is attractive as it requires less
 20 intervention and produces an engineered cell that is similar to a wild-type cell. The disadvantages are that the natural fluorescence is not as high as in naturally fluorescent proteins or organic dyes, and the excitation and emission peaks are fixed and cannot be changed. For the present invention, the fact that the excitation is in the UV region makes them more suitable as donors.

25

The second approach is using prelabelled amino acids. Various alternatives exist for fluorescent labeling of amino acids. One example is The FluoroTect™ Green_{Lys} *in-vitro*

Translation Labeling System, available from Promega (Italy), which allows the fluorescent labeling of *in-vitro* translation products through the use of a modified charged lysine transfer RNA labeled with the fluorophore BODIPY®-FL. Using this system, fluorescently labeled lysine residues are incorporated into nascent proteins during translation.

5 The third alternative makes use of unnatural amino acids. These are incorporated into a protein by clever use of site-specific, unnatural amino acid mutagenesis, combined with use of the amber suppressor tRNA (Cornish *et al.*, “*Site specific incorporation of biophysical probes into proteins*”, Proc. Natl Acad. Sci. USA, Vol. 91 2910-2914, 1994). In this method, a highly fluorescent unnatural amino acid (such as 7-azatryptophan) is charged
10 onto an amber suppressor tRNA. In parallel, the gene of interest is mutated to include one or more amber codons in predetermined sites. This is loaded into an *in-vivo* or *in-vitro* translation system, and the protein synthesis system incorporates the unnatural amino acid wherever the amber codon is present in the mRNA sequence. This method suffers from several drawbacks, including the inability of recharging the suppressor tRNA and the need
15 for interfering with the original protein sequence. However, it is useful for verifying the proper functionality of a PSM system, both *in-vitro* and *in-vivo*, as disclosed in detail below.

DD3 Optical apparatus, data acquisition, signal generation and analysis

20 Scanning versus wide-field microscopy

 There are two general classes of fluorescence microscopic tools for single-molecule fluorescence studies, either of which may optionally be used with the present invention. The first class involves point detection with detectors that have single elements (photomultiplier tube (PMT) or silicon avalanche photodiode (APD)) used in combination with a confocal
25 scanning optical microscope (CSOM) or near-field scanning optical microscope. The second class uses wide-field microscopy with two-dimensional detectors such as a CCD camera. One advantage of wide-field microscopy is that hundreds of single-molecules can be detected simultaneously, effectively performing hundreds of single- molecule experiments in parallel. This is especially useful for irreversible reactions or for very rare biological events.
30 However, because an arrayed detector has to be used, the time resolution and the sensitivity are not as good as those of point detection cases.

Wide-field microscopy can be done either through epi-illumination or through prism type evanescent field excitation. In epi-illumination, the excitation light is sent through the epi-illumination port of a conventional fluorescence microscope. Unlike in CSOM, autofluorescence generated from the microscope optics and sample cannot be removed, resulting in an inferior signal/noise ratio. In contrast, evanescent field excitation does not permit excitation light to propagate toward the detector and hence can reduce the autofluorescence to an undetectable level. Such an evanescent field excitation is generated by total internal reflection of the excitation light at the glass-water interface; therefore, we call this microscope a total internal reflection microscope (TIRM).

10

Confocal microscopy

Confocal microscopy allows the excitation and measurement of signals from a localized region with volume of less than 10^{-15} Liter. With appropriately labeled proteins there is a low chance of finding more than one tagged molecule in this volume. Confocal microscopes can be equipped with scanning laser illumination. The laser scans the focal plane a spot at a time, allowing images to be formed. The resulting instrument is called confocal scanning optical microscope (CSOM). In CSOM, laser excitation light is focused to a diffraction-limited spot using a high-numerical-aperture (NA) objective and the fluorescence coming from a single-molecule under the spot is collected using the same objective. A pinhole is used to block the out-of-focus autofluorescence signal to achieve single-molecule sensitivity. Unlike a commercial CSOM that raster-scans the laser beam for high-speed imaging, single-molecule CSOM typically scans the sample because the imaging speed is limited by the photon counts rather than by scanning speed. Two detectors are needed to detect donor and acceptor emissions simultaneously after their separation using a dichroic beam splitter. Computer-controlled data acquisition allows the accumulation of a large quantity of single molecule data by identifying individual molecules on the surface and taking the time records of single-molecule fluorescence signals.

15

20

25

Total internal reflection fluorescent microscopy (TIR-FM)

TIR-FM is a widely used technique for single molecule detection both *in-vitro* and *in-vivo*. TIR-FM, originally developed to observe the interface between two media with different diffractive indices, uses an electromagnetic field called the 'evanescent field' to

30

excite fluorophores. As the evanescent field diminishes exponentially with distance from the interface, the excitation depth in TIR-FM is limited to a very narrow range — typically one hundred to several hundreds of nanometers. Using such a narrow excitation depth is an effective way to overcome the background noise problem.

5 In Figure 7, the principle of total internal reflection fluorescence microscopy (TIR-FM) is shown. Light beam 610 passing through a TIR objective or a dove prism 630 illuminates the meniscus of two media, glass slide 600 and cell 620, obliquely from a high (n1) to a low (n2) refractive index with an incident angle that is greater than the critical angle of total internal reflection for these indices. An electromagnetic field called the 'evanescent field' (615) rises from the interface into the medium with a lower refractive index. The
10 evanescent field diminishes exponentially with distance from the interface. The decay length of the evanescent field is dependent on incident angle. In objective-type TIR-FM, a laser beam illuminates the specimen through the objective lens. As the critical angle of total internal reflection from glass (n1 = 1.52) to water (n2 = 1.33) is 61°, an objective lens that
15 has a numerical aperture larger than 1.33 should be used for objective-type TIR-FM. Specially designed objective lenses that have an NA of 1.45 (for a use with regular 1.52 glass and oil) or 1.65 (for a use with high refractive index glass and oil) are now available. The typical decay length of an evanescent field is one hundred to several hundreds
20 nanometers, whereas the thickness of various regions of a typical cell is between 0.1 µm in lamellipodia to ~10 µm at the nucleus. Typical distances between the ventral cell surface and the glass surface are ten to a few hundred nanometers. The circles represent fluorescent molecules that, in TIR-FM, are visible (640) and invisible (650).

Although TIR-FM provides superior contrast compared with other far-field
25 microscopy techniques, its application is limited to the proximity of the cell surface that is, to studying parameters in two dimensions. To observe single molecules deep inside cells in three dimensions, the methods of confocal or two-photon microscopy are applicable.

Only sparsely labeled samples (<10 particles/µm²) can be visualized as single
30 molecules using TIR-FM or confocal fluorescence microscopy owing to the low spatial resolution. Additional information can be found in Sako, Y. & Uyemura, T., *Total internal reflection fluorescence microscopy for single-molecule imaging in living cells*. Cell Struct. Funct. 27, 205–213 (2002), and Funatsu, T., Harada, Y., Tokunaga, M., Saito, K. &

Yanagida, T., *Imaging of single fluorescent molecules and individual ATP turnover by single myosin molecules in aqueous solution*. Nature 374, 555–559 (1995).

Two-photon microscopy (TPM)

5 Two-photon microscopy (TPM) is a form of laser-scanning microscopy that uses excitation that has about half the energy required to excite the fluorescent label. This type of excitation is termed two-photon excitation (TPE). The technique relies on the phenomenon of near simultaneous absorption of two photons by the same molecule. When this event occurs, the fluorophore is excited, and subsequently relaxes while emitting a photon with its
10 standard emission characteristics. Obviously, for two photons to be absorbed simultaneously (within 10^{-16} second), the flux of photons must be very high. This special situation produces the unique characteristics of two-photon microscopy: the fact that the excitation depends on the square of the energy ensures that excitation occurs only in a very small sample volume, in the beam's focus, with practically zero background excitation; the long wavelength
15 enables deep penetration into cells, tissues and even live organisms (Zipfel WR, Williams RM, Webb WW. *Nonlinear magic: multiphoton microscopy in the biosciences*. Nat Biotechnol. 2003 Nov; 21(11):1369-77, Heinze, K.G., Koltermann, A., and Schwille, P., *Simultaneous two-photon excitation of distinct labels for dual-color fluorescence crosscorrelation analysis*, 2000, PNAS 97 (19), 10377-10382). Additionally, the unique
20 spectral characteristics of the TPE spectra allow the simultaneous excitation of several different fluorophores with the same two-photon illumination.

Since its discovery in 1990 (Denk, W. et al., *Two-photon laser scanning fluorescence microscopy*, science 248, 73-76 (1990)), TPM has been used in a variety of applications, from measuring calcium dynamics in brain slices and live animals, to *in-vivo* studies of
25 angiogenesis and metastasis, to studies of hamster embryo development.

The high intensity of photons required for TPE is basically achieved in two ways. First, a laser beam is focused through a confocal laser-scanning microscope. In the focal plane, this yields the order of 5×10^{24} photons per cm^2 per second. This creates some TPE, but coupled with the low detection efficiency it is insufficient for imaging. The next level of
30 intensity concentration is achieved by a mode-locked titanium sapphire (Ti:S) laser, that produces about 80 million pulses a second, each with about 100fs duration. Thus, with the same average intensity, maximal intensity is increased drastically and the intensity of TPE is

increased by about 5 orders of magnitude. In view of these properties, the focal point of a TPM image is very sharp, and the light impinging on it is well structured. The emission photons, on the other hand, are scattered, sometimes considerably. Thus, a primary consideration in detector choice is the collection angle, and direct detectors such as large area photomultiplier tubes (PMT) close to the objective lens are appropriate.

Most types of fluorophores have been used with TPM, starting from molecules that have a relatively small action cross-section such as NADH, and ending with quantum dots that allow TPM with a few microwatts of laser power.

The main advantages of TPM are due to localized excitation, expanded wavelength accessibility of most fluorophores and the complete alleviation of out-of-focus photobleaching and photodamage. In addition, the ability of TPM to simultaneously excite different types of fluorophores with the same laser is important in many applications as well as in PSM.

Since 1996, TPM instruments are available from several manufacturers: Biorad Microscience (Hemel Hempstead, UK), Zeiss (Oberkochen, Germany) and Leica (Wetzlar, Germany). Commercial Ti:S lasers for TPM are available from Spectra-Physics (Mountain View, CA) and Coherent (Sunnyvale, CA).

Additional microscopy techniques

In this section several additional microscopy techniques are mentioned, that are applicable in certain embodiments to the present invention.

Fluorescent lifetime imaging (FLIM) is a technique in which the fluorescent lifetime, rather than intensity, is measured. (Emptage, NJ, "*Fluorescent imaging in living systems*", Curr Opin Pharmacol. 2001 Oct; 1(5):521-4, Bastiaens PI, Squire A., "*Fluorescence lifetime imaging microscopy: spatial resolution of biochemical processes in the cell*", Trends Cell Biol. 1999 Feb;9(2):48-52. Review). The fluorescence lifetime is the typical time that the fluorophore remains in the excited state. These lifetimes are usually in the order of nanoseconds. Microscopes equipped with FLIM can differentiate between different fluorophores that have different average lifetimes. Commercial FLIM microscopes are available, for example, from PicoQuant GmbH (Berlin, Germany). Model "MicroTime 200" is capable of single molecule detection, and can operate also in fluorescence correlation (FCS) mode.

Second harmonic imaging microscopy (SHIM) is a microscopy technique that relies on special organic crystals (Campagnola PJ, Loew LM. "*Second-harmonic imaging microscopy for visualizing biomolecular arrays in cells, tissues and organisms*", Nat Biotechnol. 2003 Nov;21(11):1356-60. SHIM is based on a nonlinear optical effect of frequency doubling. This effect requires intense laser light to pass through a special material – usually an inorganic crystal. The light emerging from the crystal has precisely half the wavelength of the incoming light. In contrast with two-photon microscopy, no fluorescence occurs, and the coherence of the laser light is preserved.

There are a vast and growing number of additional microscopy techniques, including those using fluorescent labels, techniques with non-fluorescent labels, and non-imaging techniques such as atomic force microscopy and photon tunneling microscopy, any of which may optionally be used with the present invention.

Cameras and detectors

According to the microscopy system used, a point detector such as PMT may optionally used, or an area detector such as a camera, for example. When PMTs are required, it is recommended to use a large-area PMT with high gain and low readout noise. Recently GaAsP photocathode PMTs are commercially available (Hamamatsu H7422P) which offer high quantum efficiency in the 400-650 nm range. This makes them well suited for TPM fluorescent work and in particular to PSM applications.

When wide-field microscopy is used, an imaging device is preferable for simultaneous observation of a relatively large area (100x100 microns) with a large number of pixels (1000x1000 or more). It is important to use a camera which has a high signal to noise ratio simultaneously with high frame rate. In order to achieve the high signal to noise, cooled CCD cameras are used such as available from Princeton Instruments, Vianen, Netherlands. Recently, intensified CCD cameras have been introduced such as the intensified digital CCD camera system IPentaMAX-512EFT, from Roper Scientific, Trenton, NJ. Such cameras allow the detection of individual fluorophores.

Signal generation and analysis

In Figure 8, an exemplary overview of one preferred embodiment for signal generation and analysis is presented. This example describes a general framework where each of the elements is described in more detail below. Illumination module 350 illuminates sample 354 through microscope 352, and the resulting signals are detected by detection module 356. The resultant image is then preferably transferred to computerized analysis station 360 which analyzes the images, preferably records the FRET donor and acceptor signals with their precise timing and coordinates in the image, and optionally and preferably correlates the resulting signal sequences with protein data from a database 362, to obtain protein identification data that is optionally presented on the computer screen and optionally stored in database 362 for further analysis.

The optical data from detection module 356 is received by the computerized analysis station 360 as a sequence of images, preferably at a rate of 60-300 frames per second to ensure that the synthesis cycle, operating at a rate as high as 20 amino acids per second in bacteria (and at a much lower rate in eukaryotes) is properly sampled. An exemplary method that analyses this image sequence is shown with regard to Figure 9. Image sequence 400 is first received by recording module 402. An image 403 is processed by preprocessing module 404 that identifies putative signals in the single image. These signals are output as a list of coordinates 405 to signal sequencer module 406 that tracks the signals and clusters them into a list of separated signal sequences 407. In this process random or otherwise unmatchable signals are filtered out. A signal sequence is preferably of the form $S = (t_1, x_1, y_1, s_1), (t_2, x_2, y_2, s_2), \dots, (t_n, x_n, y_n, s_n), \dots$. Where t_i denotes a timing value, x_i, y_i denote image coordinates, and s_i denotes signal type or intensity (of both donor and acceptor). Signal sequencer module 406 updates this list of sequences S and each updated sequence is sent to sequence analyzer 408 which transforms the sequence S into one or more data-stream 409 of FRET on/off signals, as further described in detail in the simulation experiment below (section entitled "data interpretation simulation").

Data stream 409 is preferably sent to protein identification module 410 that processes the data stream 409 and preferably retrieves a list 411 of protein sequences that putatively match data stream 409. A scorer module 412 preferably determines, for each candidate protein sequence from list 411, the probability that this protein is responsible for the observed signal sequence. The scored list 413 of scored protein candidates is optionally and

preferably analyzed, and preferably each protein candidate **415** with a probability higher than a predetermined probability threshold is displayed on the screen. Each such protein candidate **415** is also preferably recorded in database **420**. A more detailed description of data analysis is described in the data interpretation simulation detailed example below.

5

Multiple ribosome monitoring

In yet another preferred embodiment of the present invention, an optional, exemplary method is disclosed by which a plurality, tens, hundreds or even thousands of ribosomes can be monitored simultaneously. This method is important in order to ensure detection of rare or rarely synthesized proteins, such as proteins that have a very low copy number, sometimes less than one copy number per cell, on average. The size of the ribosome (along the mRNA) is approximately 20 nM. Along the mRNA strand, there are usually numerous ribosomes at various stages of translation. The distance between these ribosomes is about 40 nM. A typical mRNA may be attached to dozens of ribosomes, depending on the mRNA length.

15 This means that it is sufficient to tag only about 10% of ribosomes. This level of tagging can be achieved by limiting the tag concentration with respect to the number of ribosomes in the assay. There are anywhere from 1000 to 20,000 ribosomes in a single cell, so that in order to identify single-copy number proteins it is required to image 10% of that number, i.e. 100-2000 ribosomes. This can be done either in one cell or in a cell culture with tens or hundreds

20 of cells. An imaging device with pixel size of about 100nM^2 and 1000×1000 pixels will have a field of view of 100 square microns, which holds 100 eukaryotic cells. Thus, monitoring 20 ribosomes per cell (as a non-limiting example) over a population of 100 cells results in 2000 ribosomes being monitored simultaneously. This enables such a system to identify single-copy proteins in real-time.

25 There is a tradeoff between the number of ribosomes monitored, the copy-number sensitivity, and the temporal response of the system. If only about 1% of ribosomes are monitored, then a single-copy protein is detected only once in 10 syntheses, and would be expected to require about 10 times longer to detect than when about 10% are monitored, for example.

SECTION II: DETAILED EXPERIMENTAL EXAMPLES

This section provides a number of exemplary, illustrative, non-limiting examples of experiments that could optionally be performed with various preferred embodiments and optional implementations of the present invention. These examples are provided for the purpose of description only and are not intended to be limiting in any way.

E1 Labeling and wet setup for *in-vitro* protein synthesis monitoring

E1A Rhodamine-Fluorescein labeling

General description. In this example the tRNA is the FRET donor. It is labeled with fluorescein isothiocyanate (FITC), a dye whose excitation and emission peaks are 494 and 520 nm, respectively. Ribosomal protein L1 is the acceptor and is labeled with TMR (tetramethyl rhodamine), a dye whose excitation and emission peaks are 550 and 573 nm, respectively. It has been shown (Plumbridge *et al.*, NAR 8, 827-843, 1980) that tRNA labeled with this protocol retains its activity both in charging (with aminoacyl synthetases) and in the ribosomal synthesis cycle. The example shows labeling of tRNA^{phe} but any tRNA with similar structure (X base) can be similarly labeled (see tRNA base modification table in the section entitled "tRNA labeling" above). The labeled tRNA and ribosomal protein are constituted into an *in-vitro* translation system, and used to translate an appropriate mRNA. In this system the tRNA species that is introduced is unique since after the salt-wash stage no tRNA remains. This enables verification of the system's functionality, by comparing signals in a system where all tRNA^{phe} are labeled, as opposed to a similar system in which all tRNA^{phe} are unlabeled. A poly-U mRNA is used as the translation template. Similar comparisons can be done with poly-U template versus other templates that do not code for phenylalanine. Obviously this illustrative system can be used in many additional forms, using additional tRNAs and various mRNAs to produce signals that can be predicted and compared with observation according to the present invention. Note: Instead of (or in addition to) labeling ribosomal protein L1, ribosomal protein S1 could also optionally be similarly labeled, and there are numerous additional labeling strategies that could optionally be adopted.

Donor labeling -tRNA^{phe} labeling with FITC - Pure E. coli tRNA^{phe} (Roche Applied Science, Mannheim, Germany) is labeled at the X base (position 47) with FITC (Sigma)

(see for example Plumbridge *et al.*, NAR 8, 827-843, 1980, and Robbins *et al.*, Biochemistry 22, 5674-9, 1983). Approximately 1ml of tRNA^{phe} (130A₂₆₀ units) are dialyzed for 8h against a solution of 1M NaCl and 50mM Hepes-KOH (pH 8.0). After dialysis of the tRNA, a dimethylformamide solution containing 100mM FITC is added to
5 give a final dye concentration of 10mM. The reaction mixture is incubated for 5h at 37° C and then brought to 100mM KCl, and the tRNA is precipitated by addition of 2 volumes of ethanol and incubation for 2h at -20° C. The labeled tRNA is further separated from unreacted dye by two additional ethanol precipitations.

Unlabeled tRNA is removed by passing the tRNA over a BD-cellulose (Serva)
10 column equilibrated with a solution containing 400mM NaCl, 50mM NaOAc (pH 5.0), and 10mM Mg(OAc)₂. The labeled tRNA is loaded in a minimal volume of the same solution. Then, a salt gradient of 0.4-2M NaCl is applied to the column. The unlabeled tRNA is eluted first, followed by elution of the tRNA^{phe-X-F}. The labeled tRNA is concentrated by ethanol precipitation in the presence of 2% NaOAc and subsequently dialyzed versus buffer
15 containing 10mM PIPES, 10mM Mg(OAc)₂, 100mM NH₄Cl, 150mM KCl and 1mM DTE. The tRNA that is used in all experiments is nearly 100% labeled. Where necessary, this is accomplished by isolation of the specific labeled tRNA species using HPLC, as described in [Odom *et al.*, Methods Enzymol. 164, 174-187, 1988].

20 **Acceptor labeling- ribosomal protein labeling with Tetra-methyl rhodamine (TMR):** cf protocol of supplier, molecular probes FluoReporter, Tetramethylrhodamine Protein Labeling Kit (F-6163).

Aminoacylation of labeled tRNA^{phe} – Cell-free translation systems may include only
25 the ribosomal machinery and whatever tRNAs are chosen to be introduced, or else they may include the entire enzymatic set including the 20 aminoacyl synthetases and the amino acids required for recharging the tRNAs. An example for the latter type of system is described in Shimizu *et al.*, Nature Biotech. 19, 751-5, 2001. When the synthetases are not present, as described in this illustrative example, it is necessary to separately charge the
30 labeled tRNA with the appropriate amino acid in order for the tRNA to function during protein synthesis. Note that in this illustrative example tRNA species that are present in the system are only those which are expressly introduced. Charging the labeled tRNA with phenylalanine proceeds according to the following protocol (Plumbridge *et al.*, NAR 8,

827-843, 1980, Johnson *et al.*, J. Mol Biol. 156, 113-40, 1982) (additional, different protocols can also be found in Robbins *et al* Biochemistry 20, 5301-9, 1981, and in Janiak F *et al*, Biochem 29, 4268-77 1990.) The reaction mixture contains 20 μ M phenylalanin, 2mM ATP, 300 μ g of S100 enzymes (purified as described in Johnson *et al.*, J. Mol Biol. 156, 113-40, 1982) and approximately 0.2 μ M tRNA in final volume of 5ml buffer containing 100mM Tris-HCl (pH 7.5), 10mM Mg(OAc)₂, 20mM KCl and 1mM DTE. Following incubation of 30min at 37°C, the Phe-tRNA^{phe} is two times phenol extracted and two times ethanol precipitated. The Phe-tRNA^{phe} is further purified by chromatography on a Sephadex G25 column (Pharmacia) at 4°C in 1mM potassium acetate (pH 5.0), and then reprecipitated. After resuspension in 1mM potassium acetate (pH 5.0), the tRNA is dialyzed versus the same buffer before storage at -70°C.

Plasmid construction and overexpression of ribosomal proteins Ribosomal proteins L1 or S1 are amplified by PCR from E.Coli genome and cloned into vector pET21a (Novagen) to generate His-tagged protein plasmids (see for example Shimizu *et al.*, Nature Biotech. 19, 751-5, 2001). The plasmids obtained are transformed into E. coli BL21/DE3 strains. His-tagged proteins are purified as follows: BL21 cells are grown to an OD₆₀₀ of 0.5-0.9 in Luria-Bertani (LB) broth. Isopropyl- β -D-thiogalactoside (IPTG) is added to a final concentration of 0.1mM, and the cells are grown for an additional 4h at 37°C. Collected cells are resuspended in a buffer [50mM HEPES-KOH pH 7.6, 1M NH₄Cl, 10mM MgCl₂, 0.3mg/ml lysozyme, 0.1% Triton X-100, 0.2mM phenylmethylsulfonyl fluoride (PMSF), and 7mM β -mercaptoethanol] and are lysed by sonication. Cell debris is removed by centrifugation at 100,000g for 1h at 4°C, and the supernatant is applied to a Ni²⁺ precharged Hi-trap chelating column (Amersham-Pharmacia-Biotech). The column is then washed with 10 volumes HT buffer [50mM HEPES-KOH pH 7.6, 1M NH₄Cl, 10mM MgCl₂, and 7mM β -mercaptoethanol(β ME)] containing 10mM imidazole.

Proteins are eluted with a linear gradient from 10mM to 400mM imidazole in HT buffer. Fraction containing His-tagged proteins are dialyzed against stock buffer [50mM HEPES-KOH pH 7.6, 100mM KCl, 10mM MgCl₂, 30% glycerol and 7mM β ME] and are frozen in small aliquots at -80°C. A general reference for purification of His-tag proteins can be found in Terpe K., Appl Microbiol Biotechnol. 2003 Jan;60(5):523-33.

Preparation of ribosomes and ribosomal 50S and 30S subunits (Bakin *et al.*, J. Mol. Biol. 221, 441-453 1991)- Frozen E. Coli cells (150g) are resuspended in 150ml of buffer containing 20mM Tris-HCl pH 7.2, 20mM MgCl₂, 200mM NH₄Cl, 2mM βME, at 4°C. The cells are then broken by 3 passes through a French press at 1260kg/cm². 40μl of DNase I are added and the tube is centrifuged twice for 20min at 18,000revs/min. The supernatant is centrifuged for 3h at 30,000revs/min. The pellet of 70S ribosomes is resuspended in buffer A containing 20mM Tris-HCl pH 7.2, 10mM MgCl₂, 500mM NH₄Cl, 2mM βME, and centrifuged through 30% (w/v) sucrose for 15h at 38,000revs/min. The 70S pellet is resuspended in buffer A and centrifuged for 15min at 18,000revs/min. The supernatant is dialyzed against 100 volumes of buffer containing 20mM Tris-HCl pH 7.2, 1mM MgCl₂, 200mM NH₄Cl, 2mM βME, and centrifuged through a 10% to 30% (w/v) sucrose gradient for 16h at 22,000revs/min. Fraction corresponding to the 30S subunit peak are pooled and the MgCl₂ concentration is increased to 20mM and then the 30S subunits are precipitated with 0.67 volume ethanol. The 50S subunits are precipitated with 100mg/ml polyethylenglycol (M_r 6000). The pellets of subunits are resuspended in buffer containing 20mM Tris-HCl pH 7.2, 20mM MgCl₂, 200mM NH₄Cl, 2mM βME, and dialyzed against the same buffer for 3h at 4°C. Subunits are stored in -70°C.

Preparation of ribosomes and ribosomal 50S subunits lacking protein L1 from E. Coli – preparation of 50S subunits lacking protein L1 (50S-L1) from E.coli mutant strain, which does not contain ribosomal protein L1, is performed as described in Odom *et al.*, Biochemistry 29, 10734-44, 1990, Odom *et al* Biochemistry 19 5947-54, 1980.

Incorporation of labeled L1 into 50S ribosomal subunit Labeled L1 is incorporated into 50S in a reaction mixture containing 400pmol of 50S-L1, 440pmol of labeled L1, 10mM Tris-HCl pH 7.5, 8mM Mg(OAc)₂, 150mM NH₄Cl, and 5mM βME, in final volume of 100μl. Incubation is for 10min at 35°C. Subunits isolated by centrifugation at 49,000rpm for 4h (see for example Odom *et al.*, Biochemistry 29, 10734-44, 1990).

Poly(U)-dependent polyphenylalanine synthesis by TMR-labeled ribosomes and FITC-labeled Phe-tRNA^{phe} In total volume of 100μl: 25mM Tris-HCl pH 7.5, 12-14mM MgCl₂, 25mM NH₄Cl, 100mM KCl, 3mM dithioerythritol, 4mM βME, 0.8mM ATP, 0.05mM GTP, 5mM phosphocreatine, 2.5μg of creatine phosphokinase, 4μg labeled phe-tRNA^{phe}, 20μg

poly(U), ~60µg of E coli postribosomal supernatant (prepared as described in Odom et al. Arch Biochem Biophys 230, 178-193, 1984), 5×10^{-5} M Phe (5Ci/mol), and 30S and 50S ribosomal subunits, generally 0.8 A_{260} units of 50S with optimal amount of 30S, usually 0.45-0.5 A_{260} units. The reaction mixture is incubated for 30min at 37°C. (see for example
5 Odom *et al* Biochemistry 19 5947-54, 1980; alternative protocols can be found in Plumbridge *et al.*, NAR 8, 827-843, 1980, and Shimizu *et al.*, Nature Biotech. 19, 751-5, 2001).

10 **E1B Quantum dot-Rhodamine labeling**

General description. In this example Ribosomal protein L1 is the FRET donor. It is labeled with a quantum dot whose emission peaks at 525 nm. tRNA is the acceptor and it is labeled with TMR (tetra-methyl rhodamine), a dye whose excitation peaks at 550nm and emission at 573nm. tRNA could also be labeled with FITC as in the previous example, and a quantum
15 dot with appropriate emission characteristics selected. tRNA labeled with this protocol retains its activity both in the aminoacyl synthetases and in the ribosomal synthesis cycle. The example shows labeling of tRNA^{phe} but any tRNA with 4-thiouridine in position 8 can optionally be similarly labeled. There are about 20 such tRNAs in E. Coli, see complete list in the section entitled “tRNA labeling” above. The labeled tRNA and ribosomal protein are
20 constituted into an *in-vitro* translation system, and used to translate an appropriate mRNA. Once the setup is ready, system testing can proceed as explained in the previous example. Note: Instead of labeling L1, ribosomal protein S1 could also be similarly labeled. Ribosomal protein S1 contains two cysteines, and therefore could be labeled with an appropriate protocol. For example, coumarin could be used as donor for a TMR acceptor.
25 The labeling protocols are described in Odom *et al.* Arch Biochem Biophys 230, 178-193, 1984, or Bakin *et al.*, J. Mol. Biol. 221, 441-453 1991.

Donor labeling- ribosomal protein L1 labeling with quantum dots (QD) L1 protein is first biotinylated using FluoReporter Biotin-XX protein labeling kit (Molecular
30 Probes, cat# F-2610) according to manufacturer protocol. Then, the biotinylated protein is linked to Qdot™ 525 Streptavidin Conjugate (QuantumDot) according to manufacturer protocol.

Acceptor labeling- tRNA^{phe} with TMR [cf. Yiwei et al., PNAS 94, 7932-7936, 1997, Johnson et al., J. Mol Biol. 156, 113-40, 1982] - Pure *E. coli* tRNA^{phe} (Roche Applied Science, Mannheim, Germany) is labeled at the 4-thiouridine (position 8) with tetramethylrhodamine-5-iodoacetamide - TMR (Molecular probes) 30 A₂₆₀ units of *E. coli* tRNA^{phe} are dissolved in 0.7ml of 48mM potassium phosphate pH 8.4 and mixed with 2.8ml of MeSO containing 3.1mg of TMR. After stirring in the dark for 7h, the tRNA^{phe} is removed by ethanol precipitation. The non-covalently bound dye is removed by two phenol extractions: the first is performed at pH 4.6 and a second after heat denaturation of tRNA^{phe}-TMR in 10mM Tris-HCl pH 7.0, 1mM EDTA at 85°C for 2min. The labeled tRNA is then extracted with ether. After ethanol precipitation the labeled tRNA is dialyzed against 1mM potassium acetate pH 5.0. The final tRNA^{phe}-TMR adducts are reactivated at 37° C for 10min prior to the experiment. In order to increase the activity of the TMR labeled tRNA^{phe}, it is sometimes recommended to attach the TMR label via a long tether. This attachment is made using bifunctional crosslinkers (Pierce Biotechnology, Rockford, Ill.).

All other processes described herein, including aminoacylation of labeled tRNA^{phe}; plasmid construction and overexpression of ribosomal proteins; preparation of ribosomes and ribosomal 50S and 30S subunits; preparation of ribosomes and ribosomal 50S subunits lacking protein L1 from *E. coli*; incorporation of labeled L1 into 50S ribosomal subunit; and poly(U)-dependent polyphenylalanine synthesis by TMR-labeled ribosomes and FITC-labeled Phe-tRNA^{phe}; may optionally be performed as described in the previous illustrative example.

E2 Microscopy setup

E2A Bulk *in-vitro* microscopy setup

Bulk *in-vitro* monitoring of protein synthesis, confocal microscopy, and PMT detector for detecting PSM signals.

Figure 10 shows an illustrative apparatus for bulk *in-vitro* protein synthesis monitoring, where PSM signals are generated in solution. Scanning laser 300 with appropriate wavelength and energy impinges a light beam 302 optionally through dichroic mirror 304, preferably into an inverted upright confocal microscope 306, optionally and preferably focusing on a movable fused silica slide 308 on which sample wells 310 are located. The laser energy excites the donor fluorophores, which transfer energy without

photon transfer to the acceptor fluorophores according to the scheme used. FRET energy transfer occurs when an acceptor tag is in sufficient proximity to a donor tag. When this FRET excitation occurs, the fluorescence signal emitted from the acceptor passes back through microscope 306 and dichroic mirror 304, to be collected by detector 312. An example of an available commercial system that embodies this type of optical design is the Olympus FluoView 500 confocal microscope available from Olympus America Inc., Melville, New York. The system enables a choice of laser illumination (Blue Argon (488nm), Multi-line Argon (457nm, 488nm, 514nm), Green Helium Neon (543nm), Red Helium Neon (633nm), Yellow Krypton (568nm), 442nm Helium Cadmium, 440nm Diode, 405nm Diode UV Argon (351nm), 750nm IR), a choice of PMTs with an option for several PMTs used in parallel, and several scanning modes (XY, XYZ, XYT etc). The PMT readout is transferred digitally to computer system 314 for image analysis, signal processing and subsequent identification of the proteins being synthesized.

Figure 11 shows a close-up of the exemplary system shown in Figure 10, at the sample level. Laser illumination passes through objective lens 320, which typically has a high numerical aperture such as NA=1.4 or more. The illuminated volume has the shape of a pinched cylinder, depicted by hyperbolic section 330. Movable microscope slide 322 supports well 326 in which the sample is enclosed. An imaged pixel lies in the image plane 328, bringing to a minimum the volume of illuminated sample, and thereby bringing to a minimum the number of ribosomes imaged at any one time. The FRET signals (both donor and acceptor) to be detected return along the same optical path between lines 324 and into objective lens 320, as described above.

E2B Single-molecule *in-vitro* microscopy setup

Single-molecule *in-vitro* monitoring of protein synthesis, immobilized ribosomes, wide-field microscopy, TIR illumination, and ICCD image acquisition for detecting PSM signals.

Figure 12 describes one optional but preferred embodiment for an exemplary optical apparatus for data acquisition, based on a wide-field microscope equipped with TIR illumination and intensified CCD camera. This setup is useful both for *in-vitro* single-molecule protein synthesis monitoring application, where the ribosomes are immobilized on

the microscope slide, and for *in-vivo* PSM, where the ribosomes are monitored inside living bacteria or cells. Referring to Figure 12, laser **600** is a diode-pumped doubled YAG laser (Crystalaser, Reno, NV) that can excite a wide range of dyes. Laser illumination **602** travels through a dichroic mirror **604** (Chroma Technology, Brattleboro, Vermont) and into a dove prism **606** such as a small Pellin Broca prism (CVI laser, <http://www.cvilaser.com/>) where the illumination undergoes TIR. The prism is optically coupled to the fused silica bottom of the sample chamber **608**, so that evanescent waves illuminate up to 150 nm above the surface of the fused silica. The emitted fluorescence signals (both donor and acceptor fluorescence signals) pass through objective **610** (Olympus, DPLanApo 100UV 1.3oil, or PLAPO60XO, Plan APO 60X oil immersion, NA=1.4 working distance=.15 mm), through a fluorescent filter **612** (Chroma Technology, Brattleboro, Vermont) and imaging lens **614** into intensified ccd (ICCD) camera **618** such as Cascade:512B available from Roper Scientific Photometrics, a camera that has on-chip multiplication gain and a back-illuminated CCD with dual amplifiers. In this type of camera, the impact-ionization process generates low-noise as multiplication of photon-generated charge takes place on the CCD, which undergoes deep thermoelectric cooling. This camera can be operated at 10 MHz for high-speed image visualization or more slowly for high-precision photometry. Supravideo frame rates are achievable through subregion readout. The camera readout is transferred digitally to computer system **620** for image analysis, signal processing and subsequent identification of the proteins being synthesized.

For *in-vitro* single molecule PSM, the synthesizing system must be immobilized on the microscope slide. There are two basic options for immobilization. One is to immobilize the ribosomes. Ribosomal complexes can be immobilized onto a mica surface, which is transparent and flat on a molecular size scale. Ribosomes, either labeled or unlabeled, undergo binding to mica in a few seconds, allowing the detection of single fluorescence images in aqueous buffer. A large excess of ribosomes and a short incubation period are employed for single molecule detection. The mica-bound ribosomes retain their activities, as shown in Sytnik et al., J. Mol. Biol. (1999), 285, 49-54, where detailed protocols are provided.

Another option is to immobilize the mRNA and allow the ribosomes to process the immobilized mRNA. The mRNA can be immobilized on a polyethylene glycol (PEG) coated surface with biotin-streptavidin linker. The mRNA should undergo 3'-end biotin labeling.

Since protein synthesis will not end normally because of the linked 3' end, it is advisable to ensure that the template mRNA continues for at least 90 nucleotides beyond the stop codon.

E2C Single-molecule *in-vivo* microscopy setup

5 **Single-molecule *in-vivo* monitoring of protein synthesis, live cells, confocal scanning optical microscope (CSOM), two-photon fluorescence illumination, and GaAsP photocathode PMT detector for PSM signals.**

Figure 13 describes one optional but preferred embodiment for an exemplary optical apparatus for data acquisition, based on a scanning two-photon microscopy system. This setup is useful for monitoring protein synthesis in single ribosomes *in-vivo*, in prokaryotic bacteria or cells of higher organisms. It is also optionally useful for *in-vitro* PSM assays according to the present invention. Referring to Figure 13, laser 650 is a Nd:YVO₄ pump laser producing 10 W power that drives the mode-locked Ti:S pulsed laser 652. The Ti:S laser provides up to 1 W at the peak wavelengths of the laser. The pulsed beam from Ti:S laser 652 enters a beam scanner 654 that allows control of the beam intensity, as well as adjusting the size of the beam at the back aperture of the objective, thereby controlling the parameters of two-photon excitation spot geometry. The beam scanner, or beam-conditioning unit, provides the control of beam alignment, intensity and size and its main purpose is to optimize the filling of the objective lens by the scan beam. The main role of the beam scanner is to scan the beam over the image area and thereby produce the sampled image. The conditioned, scanned beam 656 now travels to microscope 660, through dichroic mirror 658 into objective 662 and focused onto the live cell sample in sample holder 668. The fluorescent signals are collected again by the objective, passed through the mirror and detected by PMT detector 664. The detected digital data is transferred digitally to computer system 666 for image analysis, signal processing and subsequent identification of the proteins being synthesized. An example of an available commercial system that embodies this type of optical design is the Radiance 2100™ MP multiphoton microscopy system available from Bio-Rad Laboratories, cell science division, Hercules, CA. In this instrument, scanning speeds of 25 to 1800 Lines Per Second (LPS) and frame rates of 45 frames/sec can be obtained, with a wide choice of lasers, basic microscopes, and detectors, including true photon counting of up to 20M photons per second. Various scanning modes (XY, XYZ, XYT etc.) are also available.

E3 Monitoring of protein synthesis *In-vivo*

E3A General description of *in-vivo* PSM.

This illustrative example describes the use of CHO (Chinese hamster ovary) cells but
 5 any other cell line or bacterial cell culture would do equally.

For *in-vivo* monitoring of protein synthesis, fluorescent tagging according to R-T, R-
 A or R-R strategies is performed. In this illustrative set of examples R-T tagging strategy is
 used and disclosed in detail. For R-T tagging to succeed *in-vivo*, ribosome tagging and tRNA
 tagging have to be properly handled. There are two preferred choices for tRNA labeling as
 10 FRET acceptor: FITC (excitation and emission peaks are 494 and 520 nm, respectively) and
 TMR (excitation and emission peaks at 550 and 573 nm, respectively). TMR is attached to
 the thiouridine at position 8, while FITC is attached to the X-base at position 47, as
 explained in detail previously. The ribosome is labeled as FRET donor on ribosomal protein
 L1 in this illustrative example. The particular choice of labeling fluorophore for L1 depends
 15 on the acceptor fluorophore chosen. Four exemplar illustrated donor/acceptor choices are
 shown in the following table:

Table 3

<u>L1 Donor fluorophore</u>	<u>tRNA acceptor fluorophore</u>
L1-GFP fusion protein	TMR
L1-BFP fusion protein	FITC
L1-CCPGCC- FIAsh	TMR
L1-BCCP-Qdot TM 525	TMR

20 It is important to ensure that when a certain tRNA species is labeled, practically all
 tRNAs of this species in an assayed cell are labeled. Each of the two methods below
 achieves this with a different approach. The first uses a unique (suppressor) tRNA for which
 there is no endogenous competition from unlabeled tRNA. In the second approach the
 production of unlabeled tRNA in the cell is actively downregulated.

25 For ribosome tagging, optional but preferred fluorescent labeling of ribosomal
 protein L1 as FRET donor is described in detail. Three alternative methods for *in-vivo*

tagging of L1 are described. All three require fusing L1 to an additional peptide or protein. This fusion is preferably performed by insertion of a vector encoding the fusion protein into the cells.

In a first exemplary method L1 is fused to a naturally fluorescent protein such as GFP or BFP, as described in Chalfie, M. & Kain, S. (1998), Preface in: *Green fluorescent protein: properties, applications, and protocols*, eds. Chalfie, M. & Kain, S. (Wiley-Liss, New York), pp. vii-ix, incorporated herein in its entirety.

In a second exemplary method L1 is fused to a short peptide of 6-20 amino acids containing a CCXXCC motif (for example CCPGCC). This motif binds specifically to a bi-arsenoxide group. Then FIAsh, a dye derivative of fluorescein, is added to the cells (Miyawaki et al., Nat Cell Biol. 2003 Sep; Suppl:S1-7, and references therein). The FIAsh label is membrane-permeant and non-fluorescent, and acquires fluorescence only on binding to the CCXXCC motif.

In a third exemplary method L1 is fused to a sequence tag derived from biotin carboxyl carrier protein (BCCP), thereby becoming biotinylated *in-vivo* (Nilsson *et al.*, "Affinity Fusion Strategies for Detection, Purification, and Immobilization of Recombinant Proteins", Protein expression and purification **11**, 1-16 (1997)). This allows streptavidin conjugated quantum dots to be attached to the biotinylated protein. Practically, Qdot™525 Streptavidin Conjugate (Quantum Dot Corporation, Hayward, Ca) is added to the cells according to manufacturer protocol. *In-vivo* labeling with Qdots are described in Jaiswal JK, Mattoussi H, Mauro JM, Simon SM, Nat Biotechnol. 2003 Jan;21(1):47-51.

Because of resolution limits of microscopy systems, optionally and preferably only a relatively small percentage of ribosomes should be labeled. One exemplary method that achieves this goal requires placing the fusion L1 protein under the regulation of a very weak promoter, to ensure low expression levels. For the other two labeling methods, other than GFP-L1 or BFP-L1 fusion, careful control of the externally introduced dye (FIAsh or Qdots) amounts is an alternative, optional and simpler mechanism.

tRNAs are preferably labeled *in-vitro* and then delivered into the cells. tRNAs can be inserted into cells by one of at least the following three procedures: 1. by injection, as described in Ilegems, E., *et al.*, Nucleic Acids Res. 2002 Dec 1;30(23); 2. by using TransMessenger transfection reagent (Qiagen, Hilden, Germany) according to the

manufacturer protocol. 3. by using TransIT-TKO transfection reagent (Mirus Corporation, Madison, WI) according to the manufacturer protocol.

It is well known that *C. elegans* can simply absorb RNAi from solution. This ability may imply that tRNA molecules can also be simply absorbed by cells, a strategy which is preferably tested individually in each cell-line and labeling strategy.

E3B In-vivo monitoring of protein synthesis using suppressor tRNA and unnatural amino acids

General description. In order to verify the proper functioning of the PSM assay according to the present invention, suppressor tRNA may optionally be used to ensure that native tRNA does not compete with labeled tRNA during the PSM assay. The suppressor tRNA is preferably the only tRNA species to be labeled, and therefore the only one to generate a PSM FRET signal. The suppressor tRNA introduced into the cells recognizes a codon that is usually recognized by the cell as a stop codon. The amber (UAG) codon is usually employed for this aim. The suppressor tRNA is preferably not a substrate for any of the cellular aminoacyl-tRNA synthetases.

This suppressor tRNA molecule is preferably subsequently aminoacylated with a highly fluorescent unnatural amino such as 7-azatryptophan, and a special template mRNA is introduced that is engineered to contain amber codons in prespecified locations. One optional choice for the template tRNA is based on bacteriophage T4 lyzosome protein (T4L), as explained in Cornish *et al.*, "Site specific incorporation of biophysical probes into proteins", Proc. Natl Acad. Sci. USA, Vol. 91 2910-2914, 19. This fluorescent amino acid is preferably incorporated in a fluorescent protein wherever an amber codon was processed with the suppressor tRNA. Note that in this configuration the charged suppressor tRNA is doubly labeled, once as a FRET acceptor and once with the fluorescent amino acid it is charged with. In particular, the engineered T4L protein will be indicative of the functioning both of the suppressor tRNA and of the PSM assay. In this way it is possible to obtain independent verification of the results of the PSM assay. Additionally, the accuracy of the PSM method can optionally be correlated with detection of the fluorescent translation products. Important parameters such as quantitation accuracy of the PSM assay can be measured.

The suppressor tRNA is preferably constructed on the basis of the *E. coli* tRNA^{Phe}, *E. coli* tRNA^{Asn}, or *E. coli* tRNA^{Asp}, as described in the references below. All of these tRNAs have a 4-thiouridine in position 8 and so can be labeled with TMR, *E. coli* tRNA^{Phe} also has an X-base in position 47 and can therefore be labeled with FITC. Detailed labeling protocols were described previously in the section entitled "Labeling and wet setup for *in-vitro* protein synthesis monitoring".

Preparation of suppressor tRNA - details. A variety of suppressor tRNAs have been misacylated and tested for their ability to incorporate amino acids into proteins in response to an amber nonsense mutation. Chamberlain and coworkers focused their efforts on *E. coli* tRNA^{Gly} (Bain et al., *Biochemistry* 1991, 30, 5411-5421). Schultz and coworkers determined that suppressor tRNA^{Asn} from *E. coli* and tRNA^{Gln} from *T. thermophila* showed the best overall suppression efficiency for amino acid incorporation into model proteins T4 lysozyme and chlorismate mutase (Cload et al, *Chem. & Biol.* 1996, 3, 1033-1038).

In view of the strategies described above, *E. coli* amber (UAG) suppressor is optionally and preferably prepared from *E. coli* tRNA^{Phe} or tRNA^{Asn} according to the protocols in the references above. The tRNA amber suppressor has a CUA anticodon sequence. Other tRNAs can also serve as a basis for engineering a suppressor tRNA for the amber codon for PSM, as long as they contain a 4-thiouridine in position 8 or an X-base in position 47, to allow labeling. Other tRNAs that do not have these modifications may also optionally be used but an appropriate labeling strategy compliant with amino-acylation and translation should be devised.

The stages of the experiment optionally and preferably include: Creation of the suppressor tRNAs; Fluorescent labeling of the suppressor tRNAs; Charging the suppressor tRNAs with 7-azatryptophan. (cf. Cornish *et al.*, *Proc. Natl Acad. Sci. USA*, *Bol.* 91 2910-2914, 19); Insertion of a vector that codes both for the L1 fusion protein (one of 3 choices) and the template mRNA encoding for the reporter protein (such as the amber-labeled bacteriophage T4L); Once the transfected vector undergoes transcription, the labeled, charged suppressor tRNAs and any additional dyes (FIAsH or Qdots) are inserted.

E3C In-vivo monitoring of native protein synthesis

General description. In this non-limiting, illustrative example natural protein synthesis by ribosomes is monitored *in-vivo*. Labeling of a single tRNA species (tRNA^{Phe}) is described but multiple labeling is also possible.

Since the cell manufactures its own, unlabeled tRNA, its production is optionally and preferably stopped before the labeled tRNA is introduced. This stoppage ensures that nearly all tRNAs of the required species are indeed labeled. Thus endogenous unlabeled tRNAs that are part of the live cell are optionally and preferably replaced preferably fully by labeled tRNAs. Since endogenous tRNAs are necessary for cell viability, the tRNA species to be labeled is placed under induction control, so that their production can be stopped when the labeled tRNAs are introduced. The turnover rate of tRNAs, whether endogenous or externally introduced, is in the order of 1-2 days (Schlegel *et al.*, "The turnover of tRNAs microinjected into animal cells", Nucleic Acids Research, Vol 5, Issue 10 3715-3729), so that the production of the endogenous tRNAs that have been placed under control needs to be stopped a sufficient amount of time before labeled tRNAs are introduced and the PSM assay starts operating.

Preparation of cell line

CHO-ind-tRNA^{Phe} cell-line is optionally and preferably established from CHO cells in which the endogenous gene coding for tRNA^{Phe} is placed under the control of inducible POL III promoter. Such promoters are described in Wolfgang M. *et al.*, (2001) NAR 29, 1672-1682; Tuschl T. (2002) Nature Biotechnol. 20, 446-448; Van de Wetering, M., *et al.*, (2003) EMBO Rep 4, 609-15; Hurlstone, A., *et al.*, (2002) EMBO L. 21, 2303-11. The replacement of the natural control elements of the required tRNA genes by inducible control is performed by gene targeting techniques as described in (Joyner, AL (ed), "Gene Targeting: A Practical Approach", Oxford University Press; 2nd edition, 2000).

The stages of the experiment optionally and preferably include: Establishing the cell-line CHO-ind-tRNA^{Phe}; Fluorescent labeling of the E.Coli tRNA^{Phe} molecules; Insertion of a vector that contains the L1 fusion protein (optionally according to one of three previously

described choices); Down regulation of the POL III promoter driving the unlabeled tRNA^{Phe} transcription; and Introduction of L1 dyes (if required) and labeled tRNA^{Phe}.

E4 Data interpretation simulation

5 This Example describes a simulation of an illustrative method for signal processing according to the present invention. A specific, illustrative algorithm of data analysis that permits real-time identification of the protein being synthesized from raw FRET signals is described. The data processing proceeds by stages according to the following diagram (Figure 14-A). The raw, or double signal **510** is the signal obtained simultaneously from
10 donor and from acceptor of a single FRET pair, as is customary for FRET analysis. A typical graph of the double signal is shown in Figure 14-B, with acceptor signal **520** and donor signal **521**. These graphs were created by a simulation program written in C++ under Microsoft visual studio development suite. The model assumes that signals are generated with parameters as indicated below. Random number generation was used to create noise
15 according to the prescribed parameters. Donor signal is shown in thin black line, acceptor signal in thick grey line. The simulated signal generation model assumes a sampling rate of 200 samples per second, a synthesis rate of 20 amino acids per second, average “off” signal of 1.2/0.1 relative brightness values for donor/acceptor, respectively, and an average “on” signal of 0.2/0.9 for donor/acceptor, respectively. The “on” and “off” values are assumed to
20 have been previously calibrated by experimental measurements. Additional assumptions that underlie the simulation experiment model are the following: the FRET signal is “on” for 50% of the synthesis cycle time of a single amino acid, on average, with an average deviation of 10% from this value; the synthesis cycle time changes on average by 8% from the average cycle time; the signal noise level is 18% of maximal signal; and labeling
25 efficiency is 95% (that is, at most 1:20 tRNAs that should have been labeled turn out to be unlabeled).

Once the simulated PSM signal is generated, the analysis process can begin its operation. As shown in Figure 14A, the first stage in the analysis produces the FRET signal **511** from the double signal **510**. This is a binary signal at the original sampling rate. A
30 sample graph of this signal is shown in graph **530** (Figure 14-C). Only the “on” periods are shown. In this example the computation of the FRET signal involves a simple subtraction of acceptor signal minus donor signal. If this is positive, an “on” FRET bit is output, else, an

“off” bit. Note that the signals are calibrated for their “on” and “off” values. If the calibration values are different than the values shown in figure 14B, other decision schemes such as a weighted difference of the signals ($a \cdot \text{acceptor} - b \cdot \text{donor}$, with a and b some fixed positive weights) may optionally be required.

5 The next stage produces the synthesis signal **512**, which provides a time reading for each “on” period. It is assumed that when a FRET signal is emitted, it takes place only during part of the synthesis cycle. Thus, it is easy to separate adjacent FRET periods. On the other hand, when the peptide sequence includes a several adjacent non-labeled sequence elements, separation of the units is not straightforward and has to be computed. The
10 synthesis signal records the time points of the center of each FRET period. To compute this synthesis signal **512**, the beginning and end points of each FRET period are recorded first. In the simulation experiment the initial three periods occurred at times .088-.1126, .0233-.0258, .284-.308. The midpoints of these intervals, .1003, .245, .296 are the values that form the synthesis signal. All time values are given in seconds.

15 The next stage produces the label sequence tree **513**. Suppose two consecutive “on” signals were recorded at times t_1 and t_2 . The average synthesis time is known to be T_s and the standard deviation of synthesis cycles has been measured to be σ , in seconds, or $\sigma_c = \sigma / T_s$, in cycles, or intervals. The number N_{off} of “off” cycles between t_1 and t_2 can be computed with an uncertainty that can be evaluated as follows. The average time required
20 for N synthesis cycles is $T_N = N \cdot T_s$. The standard deviation of the accumulated time required for N cycles is therefore $\sqrt{N} \cdot \sigma_c$, in interval units. The standard deviation σ_{Nc} for N cycles in cycle units is therefore $\sigma_{Nc} = \sqrt{N} \cdot \sigma_c$. The distribution of the total duration of N cycles can be assumed normal with standard deviation σ_{Nc} . The conditional probability that a sequence of N synthesis cycles will deviate by at least ΔI intervals from the expected interval
25 duration is therefore $P(N, \Delta I) = P(x > \sigma_{Nc})$ and can easily be computed or found from normal distribution tables.

For example, for the time difference .245-.1003=.1447 seconds between first and second “on” periods in the simulation experiment, given an average synthesis cycle time of $1/20=.05$ seconds and standard deviation of .27 intervals, the expected number of cycles is
30 .1447/.05=2.894. Examination of the probabilities that 2, 3 or 4 cycles would require .1447 seconds yields the following values:

$$P(2, .1447): \sigma_{Nc} = .27 \cdot \sqrt{2} = .38, \Delta I = .1447 / .05 - 2 = 2.894 - 2 = .894, N(.38, .894) = .019$$

Note that the sequence with highest probability (sequence 4) is identical to the original input sequence. As the process continues, branches can split and re-split; some branches are deleted since their probability falls below the acceptable threshold; and in this way the measured label sequence tree evolves. At every stage, each candidate sequence is sent for database interrogation and scoring (see below). Branches that do not appear in the database are deleted or otherwise marked for special consideration.

The final stage in the protein identification module is the database interrogation stage. For this, the database has to be compiled. Every protein sequence is simply transformed to a label sequence by marking each amino acid as "N" or "F" according to whether its synthesis will result in a FRET signal or not. Next, all subsequences of a given length (say, 100 cycles) that start with an "N" are determined. For an organism such as E. Coli that contains under 5000 ORFs with average length of under 1000 bps yields proteins with 300 amino acid on average, so that the database for E. Coli will include less than $5000 \times (300 - 100) = 1$ million entries. This entire set of sequences is now built into a tree data structure (cf. Donald E. Knuth, *The Art of Computer Programming*, Addison-Wesley). In this tree, the sequences start from the top (null) node, and split according to the number of "F" cycles between every neighboring "N" cycles. In every node, the total number of (different) proteins covered by the branches stemming out of the node is noted. Once this number becomes lower than a prescribed number (for example 5), the set of proteins is retrieved for display or storage, together with the probabilities as discussed above. This can be done in real-time, resulting in a dynamic display of proteins as they are being synthesized.

The database can also take into account labeling efficiency. For example, if a given amino acid residue is considered to be labeled with an efficiency of, say, 90%, than every sequence where this residue appears is used to derive mis-labeled sequences at a rate of 10%. All these mislabeled sequences are stored in the database as well. This may mean that longer sequences are required to positively identify a protein.

It is possible to further analyze the relationship between the number of labeled versus non-labeled units. The R-A labeling scheme is herein analyzed as an example. The other two schemes, R-T and R-R labeling can easily be analyzed in a similar way. Suppose that k of the 20 amino acids are labeled and $20 - k$ are unlabeled. Assume that a subsequence of total length l (both labeled and unlabeled) has been read. Assume uniform distribution of amino acids. In this case, $\alpha = k / 20$ of the l residues can be expected to be labeled, so that there

would be $p = \alpha l$ labeled residues and $l-p$ unlabeled residues. The number of possible sequences would then be $N = \binom{l}{p} = \binom{l}{\alpha l}$. This number is maximal when $k = 10$ (or $\alpha = 1/2$). A realistic assumption is that for confident identification of a protein the random hit probability should be better than $1:10^6$, or, in other words, $\binom{l}{\alpha l} > 10^6$. This is because

5 there are at most several hundred thousand sequences in the database (see above). Thus, for confident protein identification, the formula $\binom{l}{\alpha l} > 10^6$ connects the ratio α of labeled amino acids with the length l of a polypeptide chain required for confident identification. The following table provides example values:

10 Table 5

Number of labeled amino acids	Minimal number of residues (l) required for confident identification	Total synthesis time in bacteria (seconds) for confident identification
1	80	4.0
3	42	2.0
5	28	1.4
6	26	1.3
10	23	1.06

Thus it is beneficial to partition the amino acids as equally as possible. It is also clear that protein identification can be obtained in under 2 seconds in bacteria (where

15 synthesis rate is approximately 20 residues a second). Protein synthesis in eukaryotes is about an order of magnitude slower.

If codons rather than amino acids are labeled, then with the simplistic assumption of uniform codon distribution, the connection between number of labeled codons and

20 identification is given in the table below.

Table 6

Number of labeled codons	Minimal number of residues (<i>l</i>) required for confident identification	Total synthesis time in bacteria (seconds) for confident identification
1	200	10.0
3	90	4.5
5	65	3.25
6	60	3.0
10	40	2.0

If probes with several different colors are used, rather than a single-colored probe, more information becomes available for identification of the synthesized protein. For example, assume that 10 amino acids are labeled with a single color probe, and the remaining 10 are unlabeled. For a peptide with *N* amino acids, there are

$\binom{N}{10} = N!/10!(N-10)!$ possible PSM signal sequences out of the total of 20^N amino acid

sequences. However, if the 10 labeled amino acids are labeled with 2 types of fluorescent probes, say 5 of each, than in this case the number of possible PSM signal sequences

becomes $\binom{N}{5} \cdot \binom{N-5}{5} = \frac{N!}{5!(N-5)!} \cdot \frac{(N-5)!}{5!(N-10)!} = \frac{N!}{5! \cdot 5! \cdot (N-10)!}$. The ratio of information

content is therefore $\left(\frac{10!}{5! \cdot 5!}\right) = 252$ fold. This means that multi-labeling can require

considerably less time to identify the protein being synthesized, with a higher confidence.

E5 APPLICATIONS OF THE PRESENT INVENTION

E5A Applications for high throughput screening assays

This example describes how the methods disclosed herein can optionally be used for the screening of a large library of chemical compounds to determine their efficacy or their potential for use as drugs. High throughput screening is a method developed since the late

1980s. Today systems are available that can screen up to a million compounds in one day. High throughput screening requires an assay to be devised that is compatible with the screening instrument, an assay that enables quick rejection of most of the compounds as irrelevant, and approves only a small fraction for continued research. The present invention is suitable for a very thorough and informative assay, as explained above, in the sense that it provides information not only concerning binding of the screened compound to a single protein target, one that has been suspected to be related to the disease for which a drug is sought, but provides, for every compound tested, information about the full spectrum of proteins induced by the compound with their expression timing. Thus, functional activity of a compound on a specific cell type can be usefully studied by subjecting it to protein synthesis monitoring assay as disclosed herein only once for a given organism or cell-line. The optional, illustrative strategy suitable for screening of a chemical compound library with the system and method disclosed herein is depicted in Figure 15. First, a cell line with tagged ribosomes is cultured and placed in a multiwell plate 450. This can have a 96 well plate format, a 384 well plate format or any other format compatible with automated screening. The wells 452 in the plate need to be optically amenable for microscopy as shown in Figures 7,10,11,12 and 13. A robot 454 administers one compound out of the library being screened into each well and protein synthesis analysis is performed by a protein synthesis monitoring system 456. A suitable sampling regime should be adopted. As an illustrative example a protein synthesis monitoring measurement for 30 seconds every 10 minutes for a total of one hour. Other regimes may optionally be also used. The list of proteins synthesized by the cell together with the synthesis timing during the sampling period for the particular well are stored in screening database 458. A sampling regime as described allows screening of 20 compounds per hour per protein synthesis measurement unit. In this way, screening of a library with one million compounds can take one year with five protein synthesis monitoring units or one month with 50. Obviously many alternative regimes can also be used.

The data obtained for each compound through this PSM screening provides a list of the proteins induced by the compounds, together with the synthesis timing. Thus, the changes of the state of the cellular machine, caused by the administration of the compound, can be discerned. As an illustrative example, if the PSM assay of one compound shows a significant increase in the production of DNA repair enzymes, this may mean that the administered compound may cause DNA damage. This obviously means that the compound

can never become a drug candidate. This type of information today is available only at toxicity studies stage in the drug development pipeline. Obtaining this kind of information at a very early stage of the process can save years of work and very large expenditures.

Bioinformatics analysis of the PSM data collected for each compound can further
5 yield information concerning the main and side effects of a compound, the states of the cellular machinery that it creates, and the protein pathways that it triggers.

Though seemingly slow compared to other screening methods, the method disclosed here has numerous attractive advantages. First, the library needs to be screened only once. Thereafter, focused screening targeted at a specific receptor or disease model can be done *in-silico*, with the computer alone, analyzing the protein synthesis data collected. Second, only
10 a tiny amount of compound is required since the library is screened only once. Most importantly, the data collected is orders of magnitude more informative and relevant to further research than single receptor binding assays or even cell-based assays. Thus, choice of drug leads and further development of drugs from these leads becomes much more of a
15 research program and less of a guesswork. In this way, over a period of several months, a hitherto unobtainable amount of critical information is compiled about each of the compounds in the library. This is in contrast with the information obtained after a full run of customary screening. For example, a customary receptor-binding assay produces only one bit of information for each compound - "binds" or "doesn't bind". In fact, screening with the
20 present invention is not so much a screening system (that rejects most of the candidates), as much as a system for assigning function for entire chemical libraries.

In this embodiment, the cells being monitored can be human cells, bacterial cultures, yeast or any other appropriate collection of cells or cell line.

25 **E5B Applications for drug development and manufacturing**

Another important application of protein synthesis monitoring is as a tool for process optimization, process control and quality control of protein production, either in bio-reactors using bacteria or cell culture, or else in cell free translation systems. In these situations, the present invention can provide indispensable information about the precise amounts of the
30 target protein being produced, as well as on the comprehensive structure of the proteome backdrop to this manufacturing, ensuring that the desired protein is produced in precisely the required environment and in the right amounts. This level of control, unavailable today, can

create a revolution in the way proteins and protein drugs are produced and certified. This can lead to new protein production methods that are easier to control than current ones.

In another optional but preferred embodiment, the present invention is optionally and preferably used to monitor proteins being produced by bacteria, yeast, cell lines, cell-free translation system protein production systems or any other protein production processes. Numerous biopharmaceuticals are thus produced, including drugs and medical agents such as insulin, human growth hormone, erythropoietin, therapeutic antibodies, and other diagnostics and medical aids. The system disclosed herein can optionally be integrated into the production system, enabling production yields and rates to be measured, controlled, and optimized in real time. Moreover, PSM can help monitor precisely the cellular state and environment during the production of the target protein. This monitoring can ensure a hitherto unavailable level of control for protein production, and can also lead to new protein production methods that are easier to control than the customary methods. This new monitoring capability can make a large impact on the quality, quantity and cost of protein production, as well as allowing tighter regulatory control of protein production.

E5C Applications for basic biological research

This example describes how the methods disclosed herein can be used for basic biological research. One important field of research is the understanding of protein and metabolic pathways in the cell. Numerous methods have been suggested and several technologies have been developed to try and decipher the complex net of protein interactions and pathways of bacteria and cells. These include protein-protein interaction mapping from assays, from computerized analysis of research papers, and from clever setups as described in (Shen-Orr, S.S., Milo, R., Mangan, S., and Alon, U., *Network motifs in the transcriptional regulation network of Escherichia coli.*, Nat Genet 2002, 31(1): 64-8). The present invention offers important advantages for pathway elucidation. Since the response of the cell to an external stimulus is instantly revealed by the monitoring of protein synthesis, the following methodology is suitable for discovering the pathways. As described in the screening application above and in Figure 15, cells are cultured and placed in a suitable screening setup. The cells are then subjected to various external stimuli, such as temperature changes, chemical deprivation (such as phosphate starvation), administration of toxic agents, attack by phages or viruses and any other stimulus that is thought to be relevant to the pathway being

investigated. The cells or bacteria are studied using the present invention for an appropriate duration before, during and after the stimulus, and the response of the protein synthesis apparatus of the cell is tabled. A computerized analysis module analyzes the different responses, including the timing order of protein synthesis, which proteins tend to co-
5 translate, what are their amounts, and what causality relationships occur between them. By virtue of having numerous different stimuli generating numerous different responses, pathway elements can be determined as explained, for example, in Rosen *et al.*, FEMS Microbiol. Ecol. 2001, and Hecker *et al.*, Int. J. Med. Microbiol 2000. The dynamic information of cellular response to external stimulus is an extremely important probe of
10 cellular behavior, which previously could not be measured.

In another optional but preferred embodiment, protein synthesis monitoring is used to identify protein pathways and protein-protein interaction maps. In this method, different chemical and environmental conditions are applied to cells or to cell lines, and protein synthesis is monitored for each one of these conditions. The protein synthesis patterns are
15 indicative of the cellular pathways, and the protein synthesis data for the entire experiment is used to map the cells protein interaction, thereby enabling understanding of the intricate connections and functions of proteins in the cells.

20 **ESD Other applications**

In view of the large number of possible applications and embodiments of the present disclosure it should be recognized that the illustrated embodiments are only particular examples and should not be taken as a limitation on the scope of the disclosure. Some of the possible additional applications which are clearly enabled by the present invention are
25 clinical applications, diagnostic applications, production of food, cosmetics, and other bioproducts, military applications concerning biological warfare, and many more.

Although the invention has been described in conjunction with specific embodiments thereof, it is evident that many alternatives, modifications and variations will be apparent to those skilled in the art. Accordingly, it is intended to embrace all such alternatives,
30 modifications and variations that fall within the spirit and broad scope of the appended claims. All publications, patents, patent applications and sequences identified by their accession numbers mentioned in this specification are herein incorporated in their entirety by

reference into the specification, to the same extent as if each individual publication, patent, patent application or sequence identified by their accession number was specifically and individually indicated to be incorporated herein by reference. In addition, citation or identification of any reference in this application shall not be construed as an admission that
5 such reference is available as prior art to the present invention.

WHAT IS CLAIMED IS:

1. A method for monitoring protein synthesis in a protein synthesis system, the method comprising:
 - providing a marker for protein synthesis in the system, said marker being detectable through detection of electromagnetic radiation;
 - detecting electromagnetic radiation emitted from the system; and
 - analyzing said emitted radiation to monitor protein synthesis activity in said system.
2. The method of claim 1 wherein the system comprises a bacterium or bacterial culture.
3. The method of claim 1 wherein the system comprises at least one cell.
4. The method of claim 3, wherein the system comprises at least one of a cell-line or a cell culture.
5. The method of claim 1 wherein the system comprises a cell-free protein translation system (*in-vitro* translation system).
6. The method of claim 1 wherein one or more of ribosomes, ribosomal RNA, ribosomal proteins, tRNAs, or amino acids in the system are artificially adapted to provide said marker.
7. The method of claim 1 wherein said marker comprises at least a portion of one or more of natural ribosomes, ribosomal RNA, ribosomal proteins, tRNAs, or amino acids.
8. The method of any of claims 1-7 wherein said marker comprises at least one photo-active component.

9. The method of any of claims 1-8, wherein said emitted radiation comprises radiation obtained by energy transfer between at least two of a plurality of components of the system.

10. The method of claim 9 wherein said marker comprises at least one fluorescent donor-acceptor pair.

11. The method of claim 10, wherein said emitted radiation comprises a FRET (Fluorescence resonance energy transfer) signal.

12. The method of any of claims 8-11 wherein said emitted radiation comprises a fluorescent signal.

13. The method of any of claims 8-12, wherein at least a portion of said marker comprises at least one of a fluorescent protein, a fluorescent dye, a quantum dot or a luminescent substance.

14. The method of claim 13, wherein said luminescent substance comprises a luminescent protein or portion thereof.

15. The method of any of claims 1-8, wherein said marker comprises a first portion being a fluorescent substance and a second portion for quenching said fluorescent substance.

16. The method of claim 15, wherein said detecting comprises detecting a reduction in emitted radiation.

17. The method of any of claims 8-16, wherein at least a portion of said marker is covalently or non-covalently bound to a tRNA.

18. The method of any of claims 8-17, wherein at least a portion of said marker is covalently or non-covalently bound to at least a portion of a ribosome.

19. The method of claim 18, wherein said portion of said ribosome is at or near at least one of the A site, P site, E site or peptide exit channel site.

20. The method of claims 18 or 19, wherein said at least a portion comprises an amino acid.

21. The method of any of claims 1-20 wherein said detecting comprises irradiating the system with electromagnetic radiation.

23. The method of any of claims 1-21 wherein said emitted radiation is detected with a microscope.

24. The method of any of claims 1-23, adapted to measure emitted radiation from a single ribosome.

25. The method of claim 24, wherein said marker comprises a donor-acceptor fluorescent pair suitable for performing single pair FRET and wherein said emitted radiation occurs upon performing single pair FRET.

26. The method of any of claims 1-23, adapted to measure signals from a plurality of ribosomes.

27. The method of claim 26, wherein said analyzing said emitted radiation comprises performing signal analysis of emitted radiation from said plurality of ribosomes.

28. The method of any of claims 1-27, further comprising:

identifying at least one protein being synthesized through said analyzing said emitted radiation.

29. The method of any of claims 1-28, wherein said detecting is performed in real time.

30. The method of any of claims 1-29, wherein said detecting further comprises:

monitoring protein synthesis by detecting a plurality of protein synthetic processes over a period of time.

31. The method of claim 30, wherein said plurality of protein synthetic processes comprise a plurality of interactions between a ribosome and a plurality of different tRNA molecules.

32. An apparatus for measuring protein synthesis by a protein synthesis system, said apparatus comprising:

a container for containing a plurality of components for the system, wherein at least one component is capable of emitting electromagnetic radiation due to a protein synthesis activity;

a detection system to measure emitted radiation from the system; and

a computational device to analyze said emitted radiation and determine the protein synthesis activity in said system.

33. The apparatus of claim 32 wherein the system comprises a bacterium or bacterial culture.

34. The apparatus of claim 32 wherein the system comprises at least one cell.

35. The apparatus of claim 34, wherein the system comprises at least one of a cell-line or a cell culture.
36. The apparatus of claim 32 wherein the system comprises a cell-free protein translation system (*in-vitro* translation system).
37. The apparatus of claim 32 wherein one or more of ribosomes, ribosomal RNA, ribosomal proteins, tRNAs, or amino acids in the system are artificially adapted to provide said marker.
38. The apparatus of claim 32 wherein said marker comprises at least a portion of one or more of natural ribosomes, ribosomal RNA, ribosomal proteins, tRNAs, or amino acids.
39. The apparatus of any of claims 32-38 wherein said marker comprises at least one photo-active component.
40. The apparatus of any of claims 32-39, wherein said emitted radiation comprises radiation obtained by energy transfer between at least two of a plurality of components of the system.
41. The apparatus of claim 40 wherein said marker comprises at least one fluorescent donor-acceptor pair.
42. The apparatus of claim 41, wherein said emitted radiation comprises a FRET (Fluorescence resonance energy transfer) signal.
43. The apparatus of any of claims 39-42 wherein said emitted radiation comprises a fluorescent signal.

44. The apparatus of any of claims 39-43, wherein at least a portion of said marker comprises at least one of a fluorescent protein, a fluorescent dye, a quantum dot or a luminescent substance.
45. The apparatus of claim 44, wherein said luminescent substance comprises a luminescent protein or portion thereof.
46. The apparatus of any of claims 32-39, wherein said marker comprises a first portion being a fluorescent substance and a second portion for quenching said fluorescent substance.
47. The apparatus of claim 46, wherein said detection system detects a reduction in emitted radiation.
48. The apparatus of any of claims 39-47, wherein at least a portion of said marker is covalently or non-covalently bound to a tRNA.
49. The apparatus of any of claims 39-48, wherein at least a portion of said marker is covalently or non-covalently bound to at least a portion of a ribosome.
50. The apparatus of claim 49, wherein said portion of said ribosome is at or near at least one of the A site, P site, E site or peptide exit channel site.
51. The apparatus of claims 49 or 50, wherein said at least a portion comprises an amino acid.
52. The apparatus of any of claims 32-51 wherein said detection system irradiates the system with electromagnetic radiation.
53. The apparatus of any of claims 32-52 wherein said detection system comprises a microscope.

54. The apparatus of any of claims 32-23, wherein said detection system measures emitted radiation from a single ribosome.
55. The apparatus of claim 54, wherein said marker comprises a donor-acceptor fluorescent pair suitable for performing single pair FRET and wherein said emitted radiation occurs upon performing single pair FRET.
56. The apparatus of any of claims 32-53, wherein said detection system measures a plurality of signals from a plurality of ribosomes.
57. The apparatus of claim 56, wherein said computational device performs signal analysis of emitted radiation from said plurality of signals.
58. The apparatus of any of claims 32-57, further comprising equipment for identifying at least one protein being synthesized through said analyzing said emitted radiation.
59. The apparatus of any of claims 32-28, wherein said detection system operates in real time.
60. The apparatus of any of claims 32-59, wherein said detection system monitors protein synthesis by detecting a plurality of protein synthetic processes over a period of time.
61. The apparatus of claim 60, wherein said plurality of protein synthetic processes comprise a plurality of interactions of a single ribosome with a plurality of different tRNA molecules.
62. A method for analyzing a chemical compound library, said method comprising:

Administering each of the compounds to a protein translation system;
Measuring a response of said system according to the method of any of claims 1-31;
Analyzing said measurement to provide information about said compound.

63. An apparatus for analyzing a chemical compound library, comprising: a well array plate comprising a plurality of wells:

a robot for placing a protein synthesis system into the wells;
a robot for administering chemical compounds into said wells; and
an apparatus according to any of claims 32-61 to analyze protein synthesis by said system.

64. A method for determining cellular protein pathways, comprising:
selecting a cellular or bacterial culture;
placing said culture in a plurality of sample containers;
subjecting said culture to at least one condition in each of said containers;
measuring protein synthesis in each of said containers according to the method of claims 1-31; and
analyzing protein expression patterns in all containers to determine protein pathways.

65. A method for ribosome labeling to allow protein synthesis monitoring, said method comprising:
selecting a fluorescent probe;
selecting a location on at least one of a ribosomal RNA or on a ribosomal protein according to at least one of a characteristic of said probe or a characteristic of at least one of said ribosomal RNA or said ribosomal protein; and
attaching said probe to said location.

66. The method of claim 65, wherein said selecting said fluorescent probe is performed according to at least one of a suitable excitation or emission property of said probe.

67. A method for protein production monitoring, said method comprising:
selecting a protein synthesis system for PSM analysis;
selecting a fluorescent probe;
selecting a location on at least one of a ribosomal RNA or on a ribosomal protein according to at least one of a characteristic of said probe or a characteristic of at least one of said ribosomal RNA or said ribosomal protein;
attaching said probe to said location to perform PSM; and
analyzing signals from said probe to monitor the protein synthesis system.
68. A method for detecting protein synthesis in a protein synthesis system, the method comprising:
providing a marker for protein synthesis in the system, said marker having a label;
attaching said marker to at least one component of the system; and
detecting said label to determine protein synthesis activity in the system.
69. Use of a marker for detecting a protein synthetic act in real time.
70. The use of claim 69, wherein said protein synthetic act comprises an interaction between a tRNA and a ribosome.
71. The use of claim 70, wherein at least one of said ribosome and said tRNA features a marker.
72. The use of claim 71, wherein both said ribosome and said tRNA feature said marker.
73. The use of claims 71 or 72, wherein said tRNA comprises a naturally fluorescent amino acid.
74. The use of claims 71 or 72, wherein said ribosome comprises a label.
75. The use of claim 74, wherein said label comprises a quantum dot.

76. The use of claim 69, wherein each of said ribosome and said tRNA features a portion of a marker.

77. The use of claim 76, wherein a first portion comprises a fluorescent acceptor and a second portion comprises a fluorescent acceptor.

78. The use of any of claims 69-77, wherein if said ribosome comprises a marker or a portion thereof, said marker or said portion thereof is covalently or non-covalently bound to ribosomal protein L1, ribosomal protein S1 or a combination thereof.

79. The use of any of claims 69-78, for performing a screening assay according to said detecting said protein synthetic act.

80. The use of claim 79, wherein said screening assay is for detecting a pathological condition in a subject.

81. The use of any of claims 69-78, for pathway elucidation through said detecting said protein synthetic act.

82. The use of any of claims 69-78, for cell state analysis through said detecting said protein synthetic act.

83. Use of a marker for identifying a protein being synthesized by a protein synthetic process in real time.

84. Use of a marker for identifying a tRNA species being used in a protein synthetic process in real time.

85. Use of a marker for identifying an amino acid species being used in a protein synthetic process in real time.

86. Use of a marker for identifying a codon species being used in a protein synthetic process in real time.

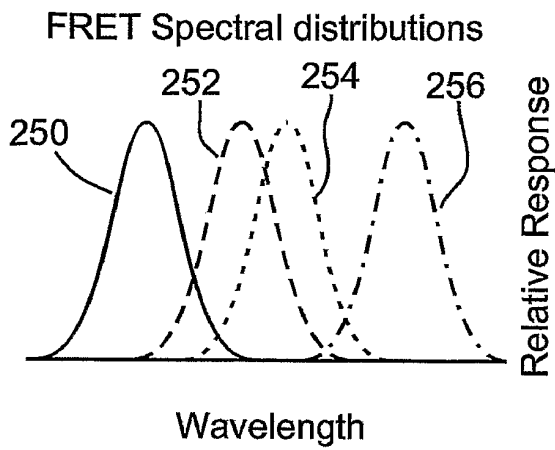

Fig. 1a

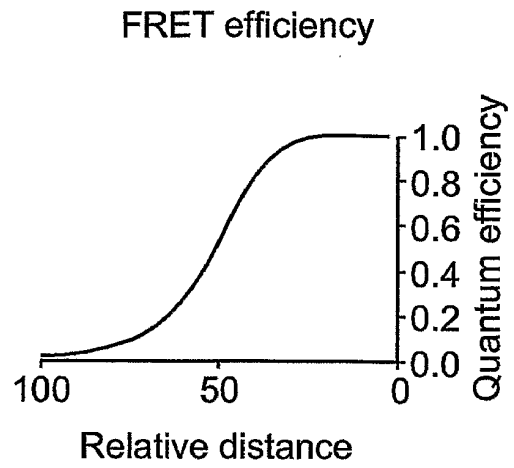

Fig. 1b

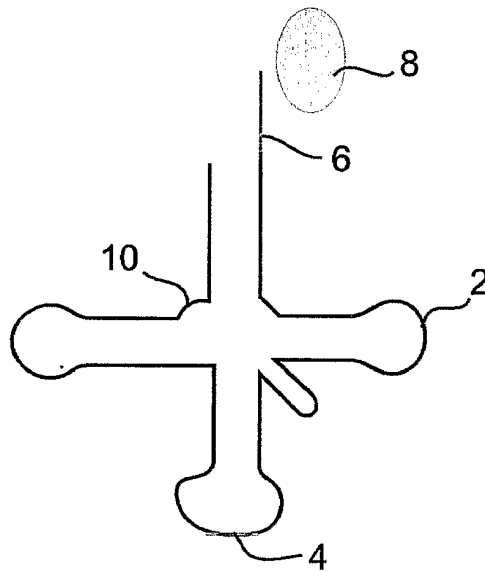

Fig. 2a

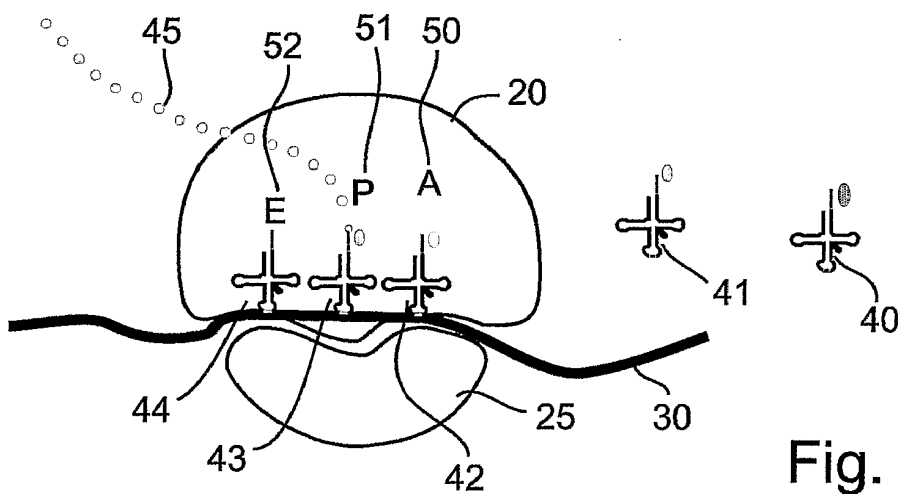

Fig. 2b

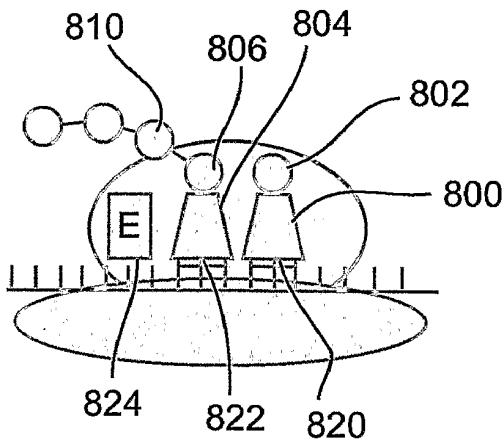

Fig. 3a

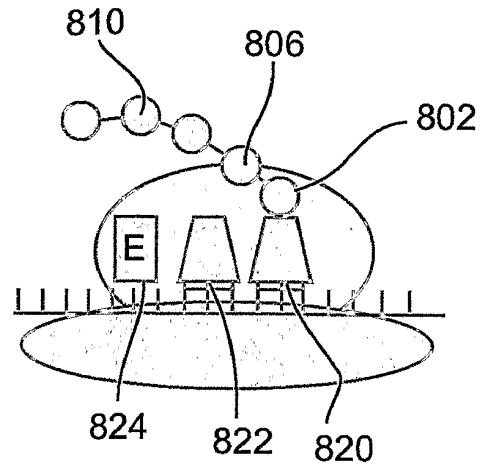

Fig. 3b

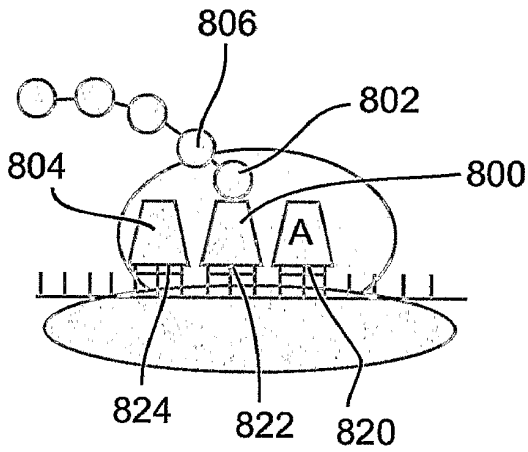

Fig. 3c

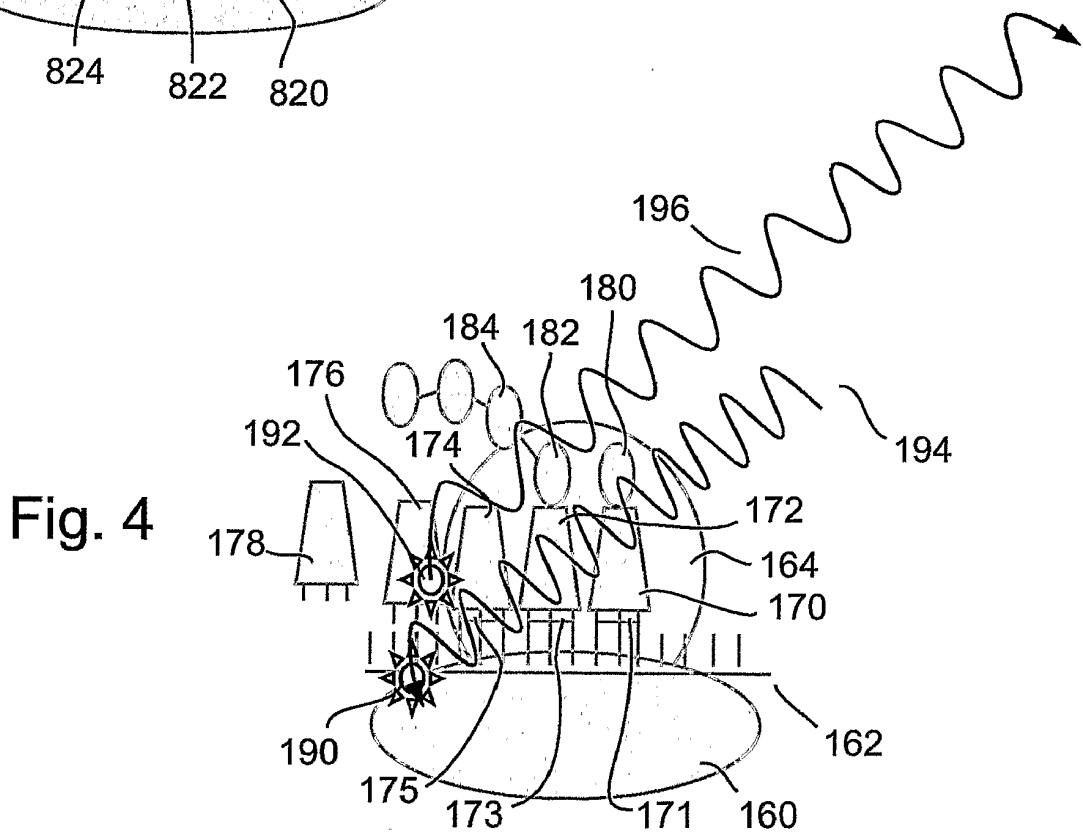

Fig. 4

Fig. 5

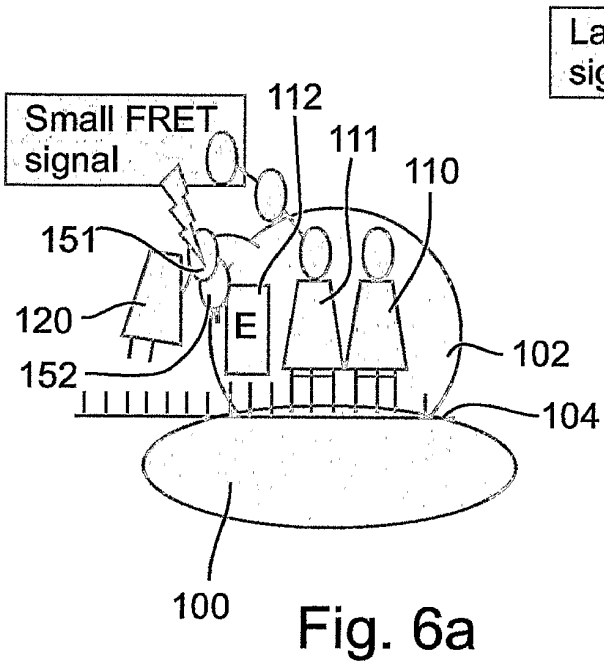
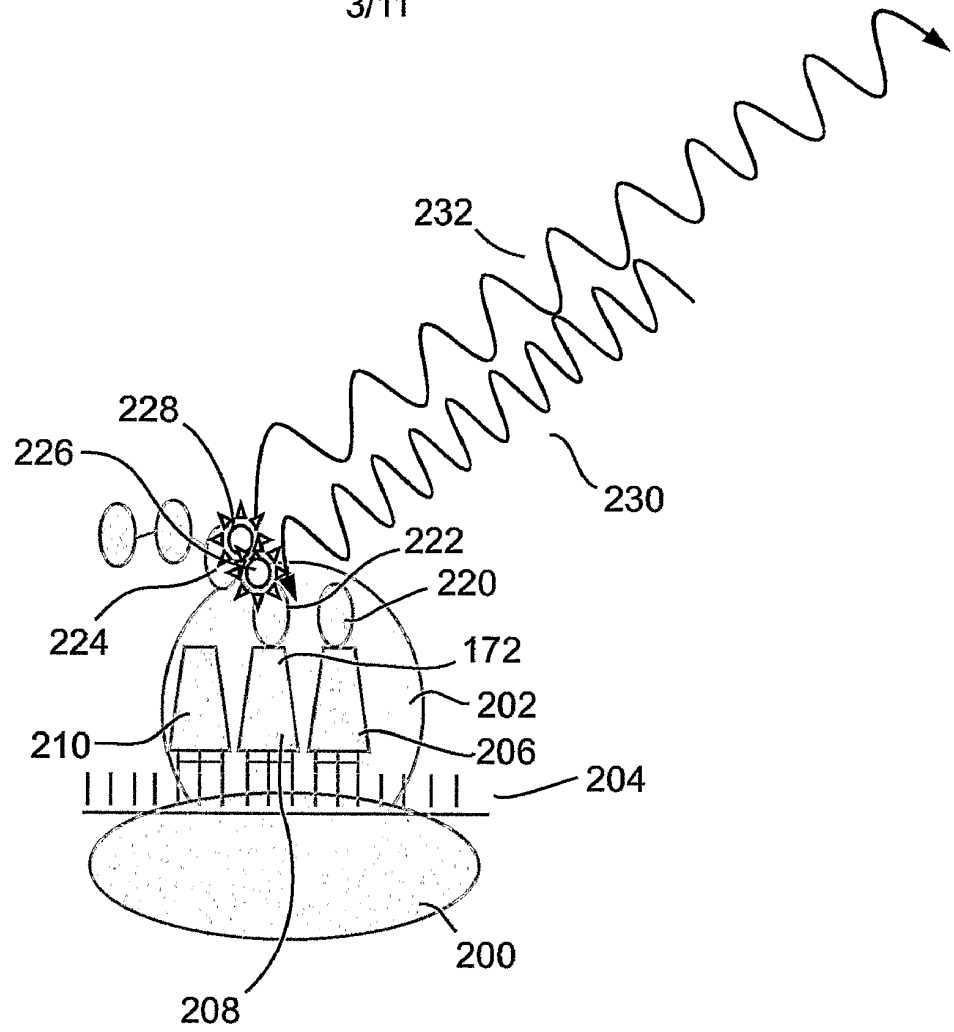

Fig. 6a

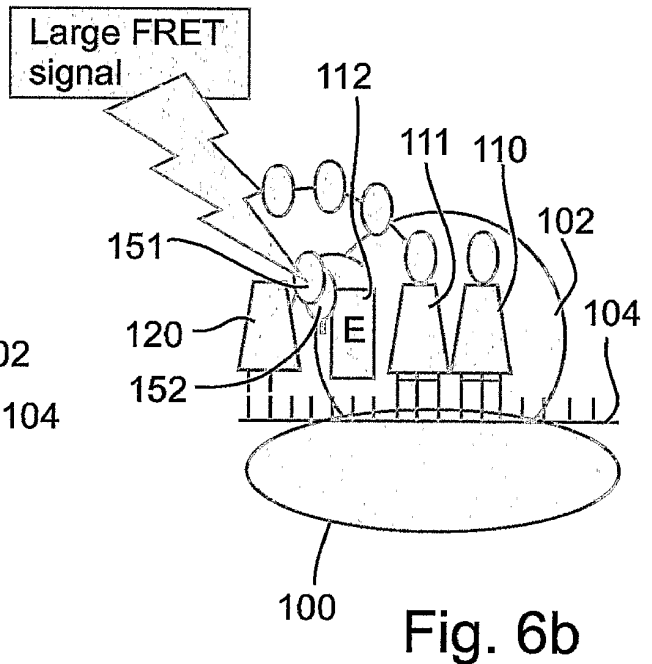

Fig. 6b

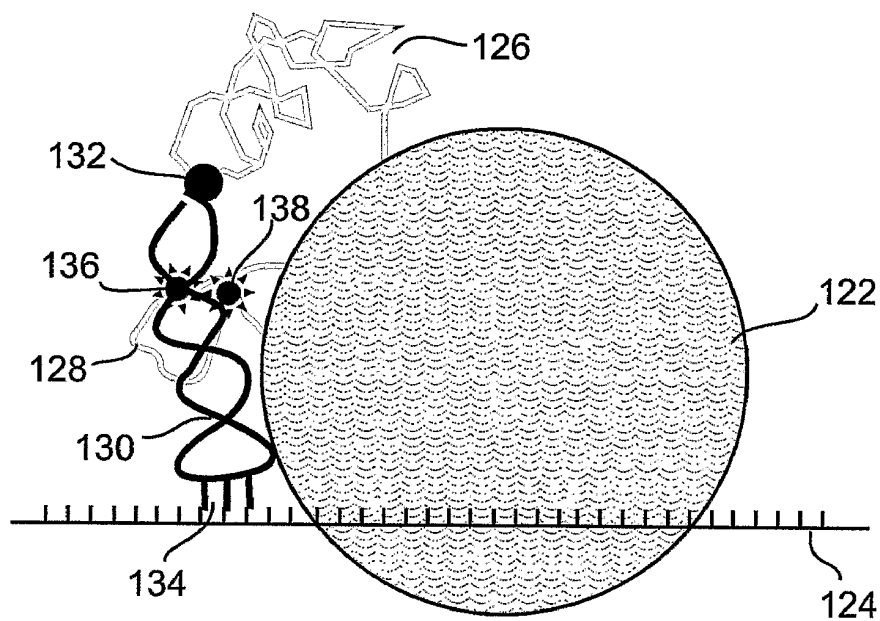

Fig. 6c

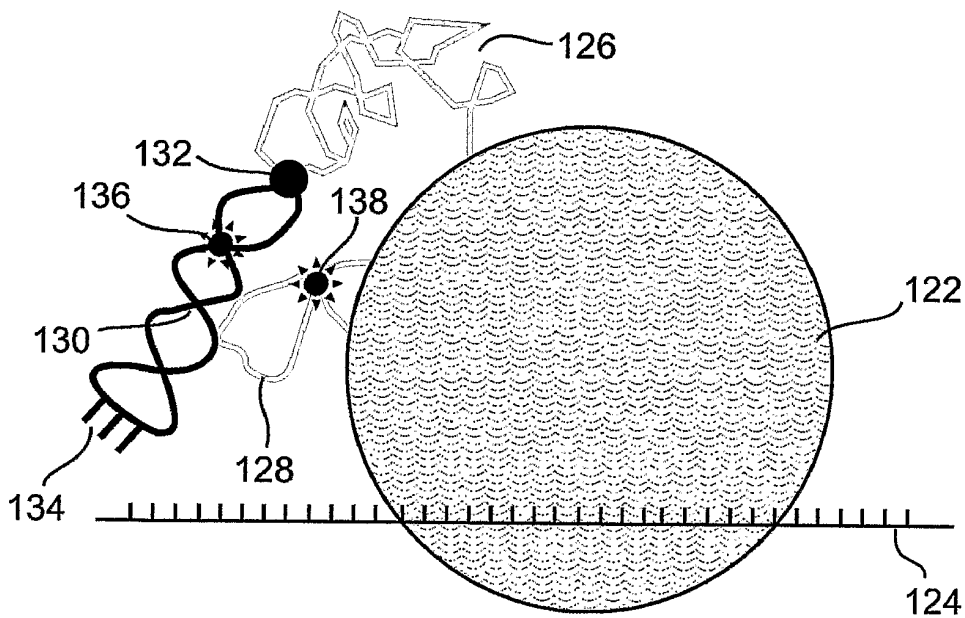

Fig. 6d

5/11

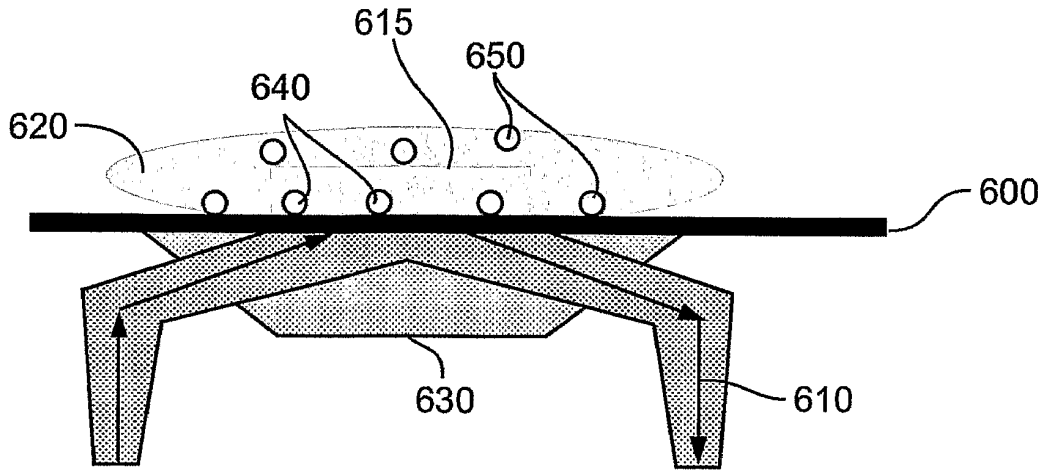

Fig. 7

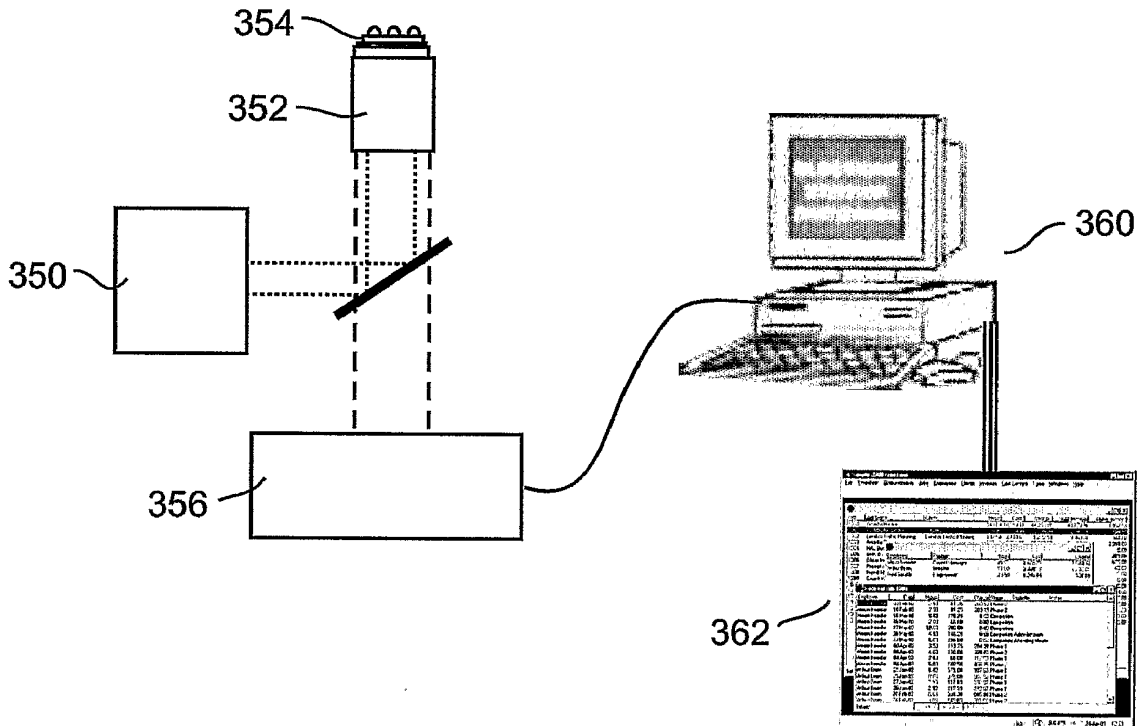

Fig. 8

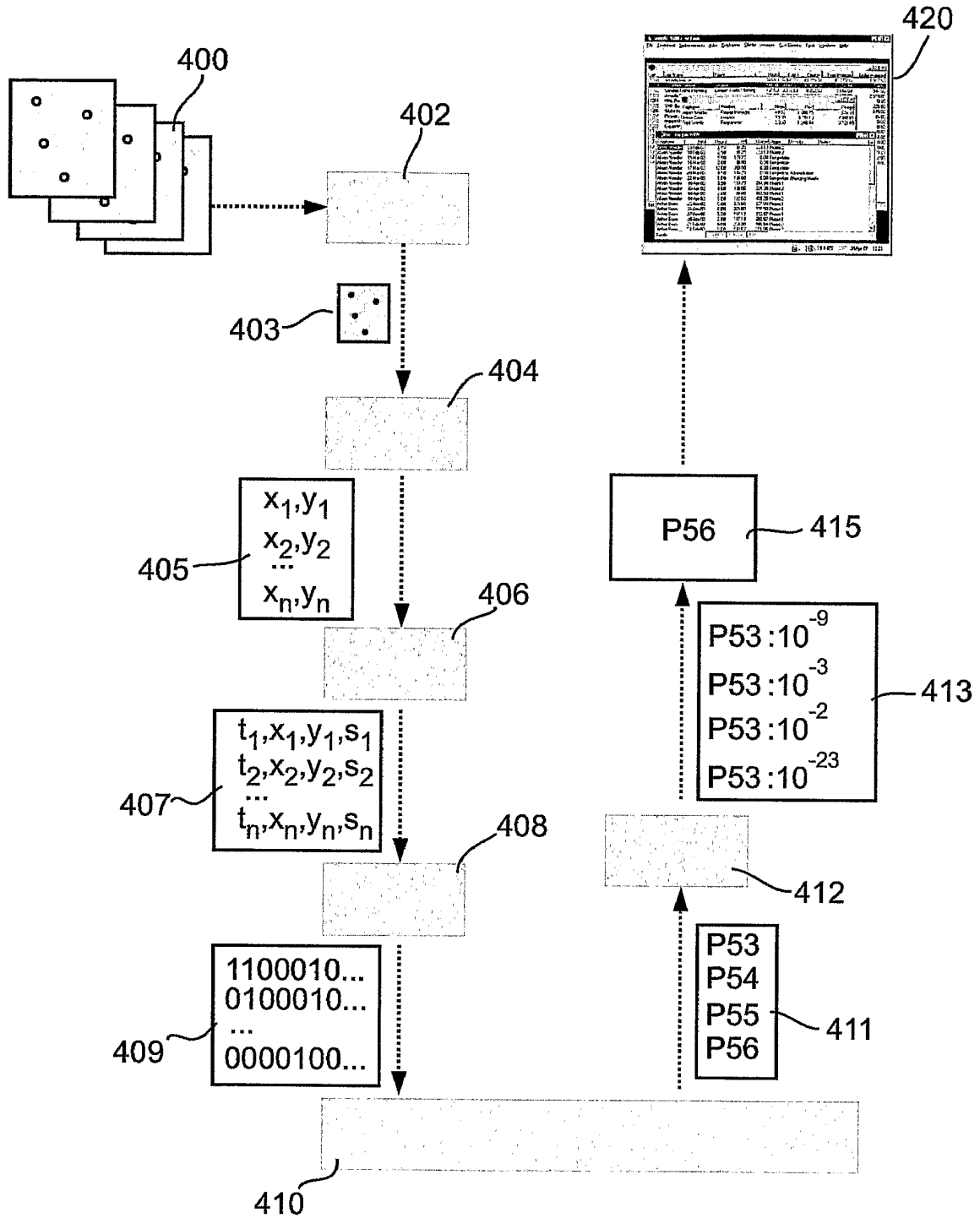
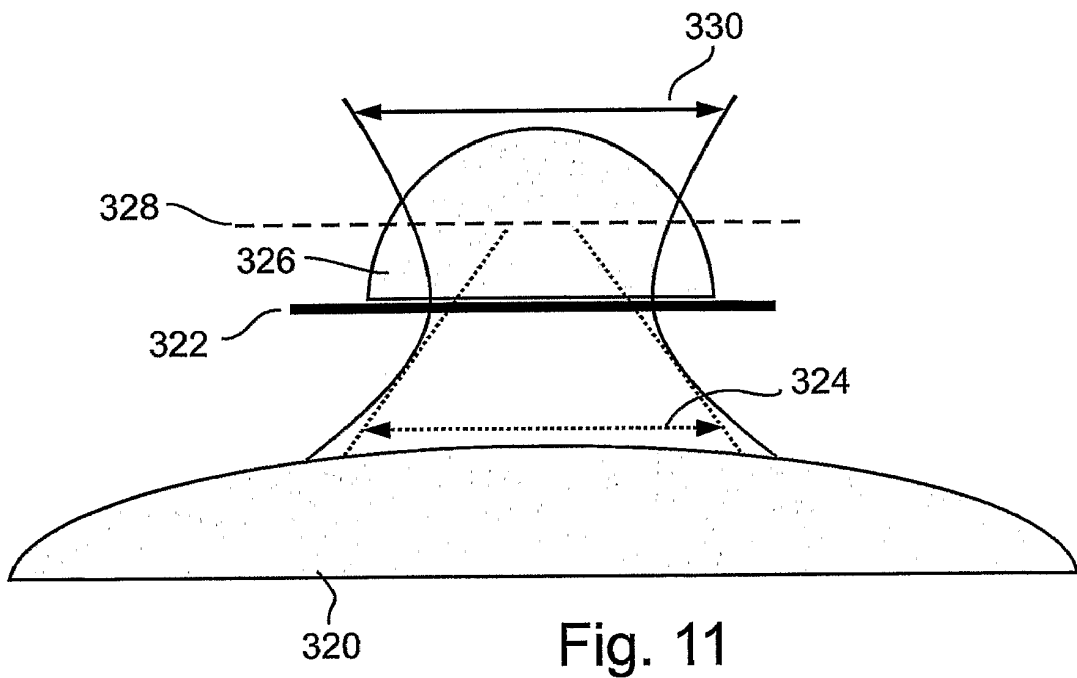
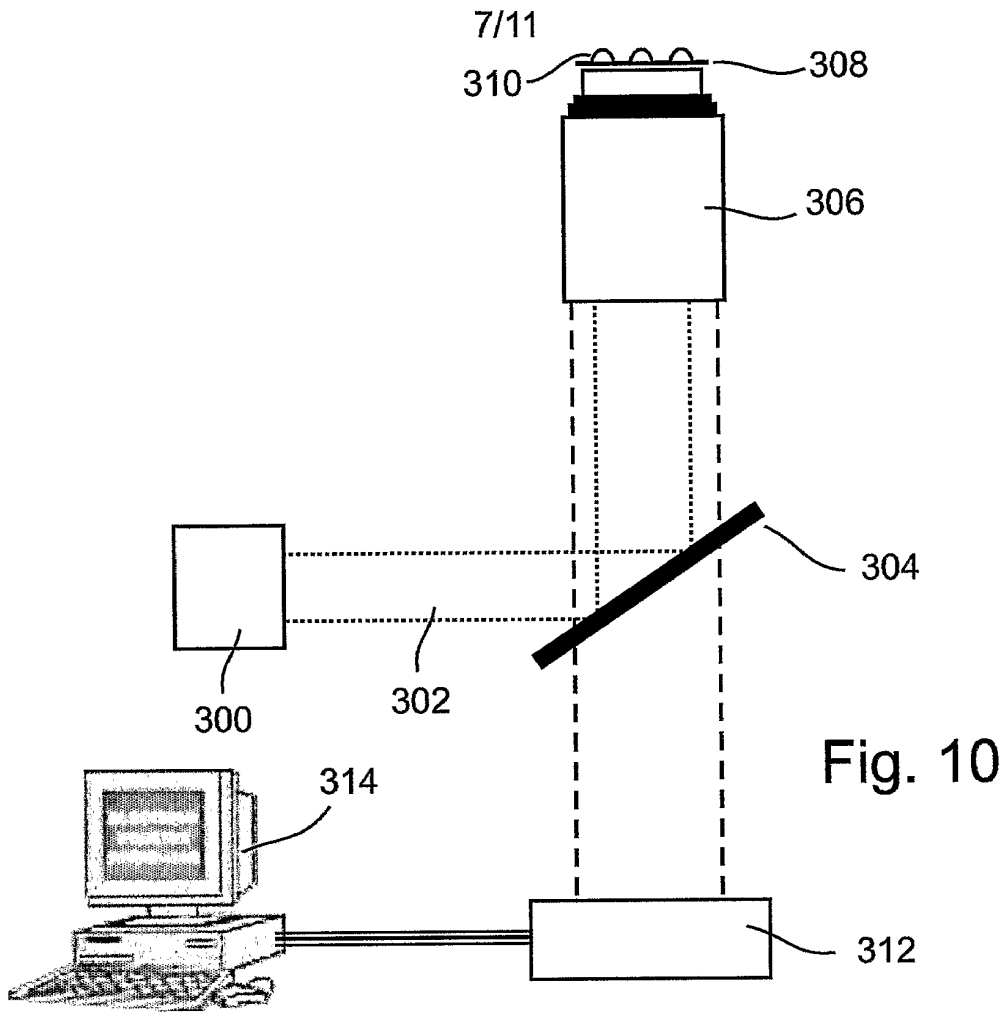

Fig. 9



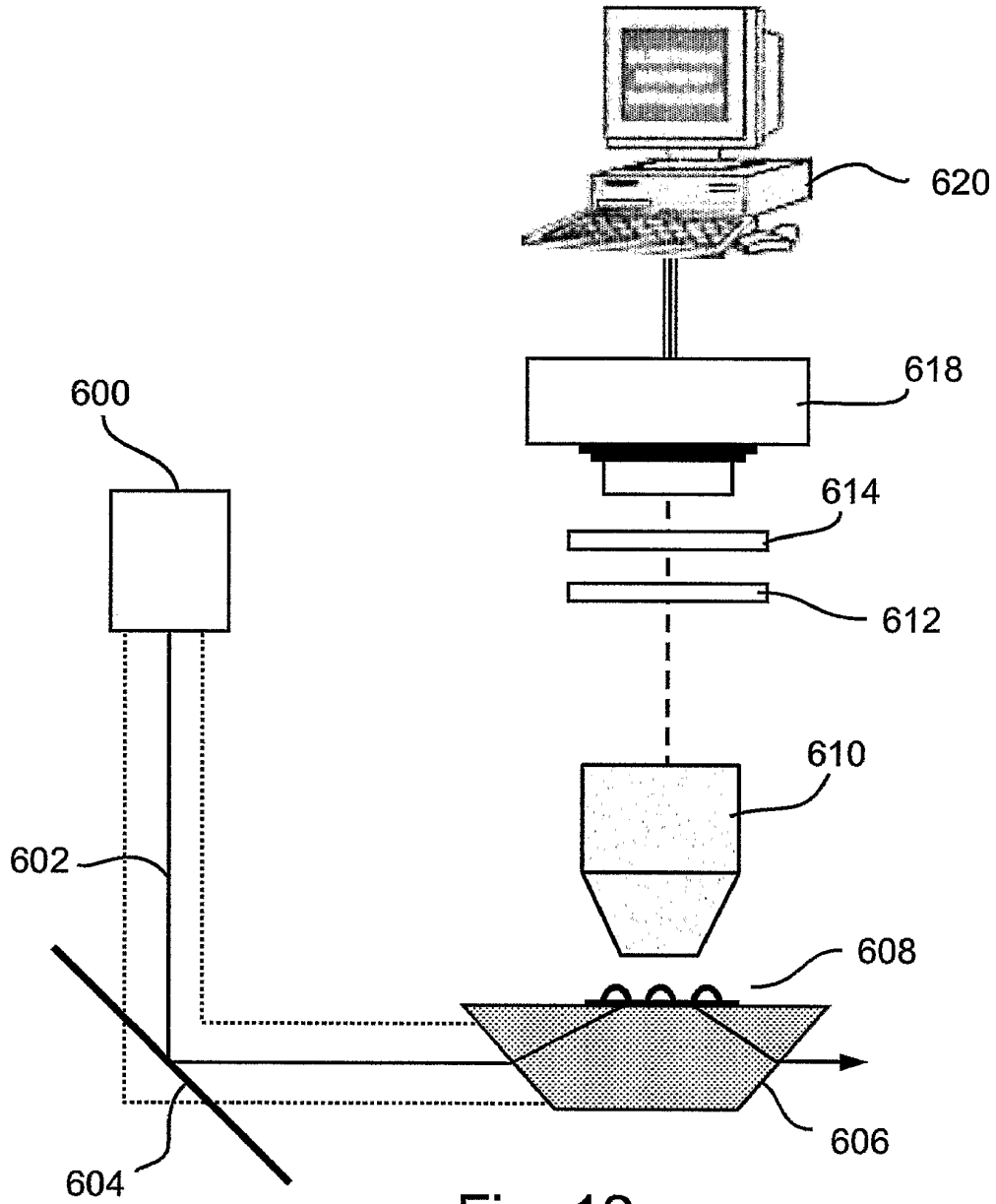

Fig. 12

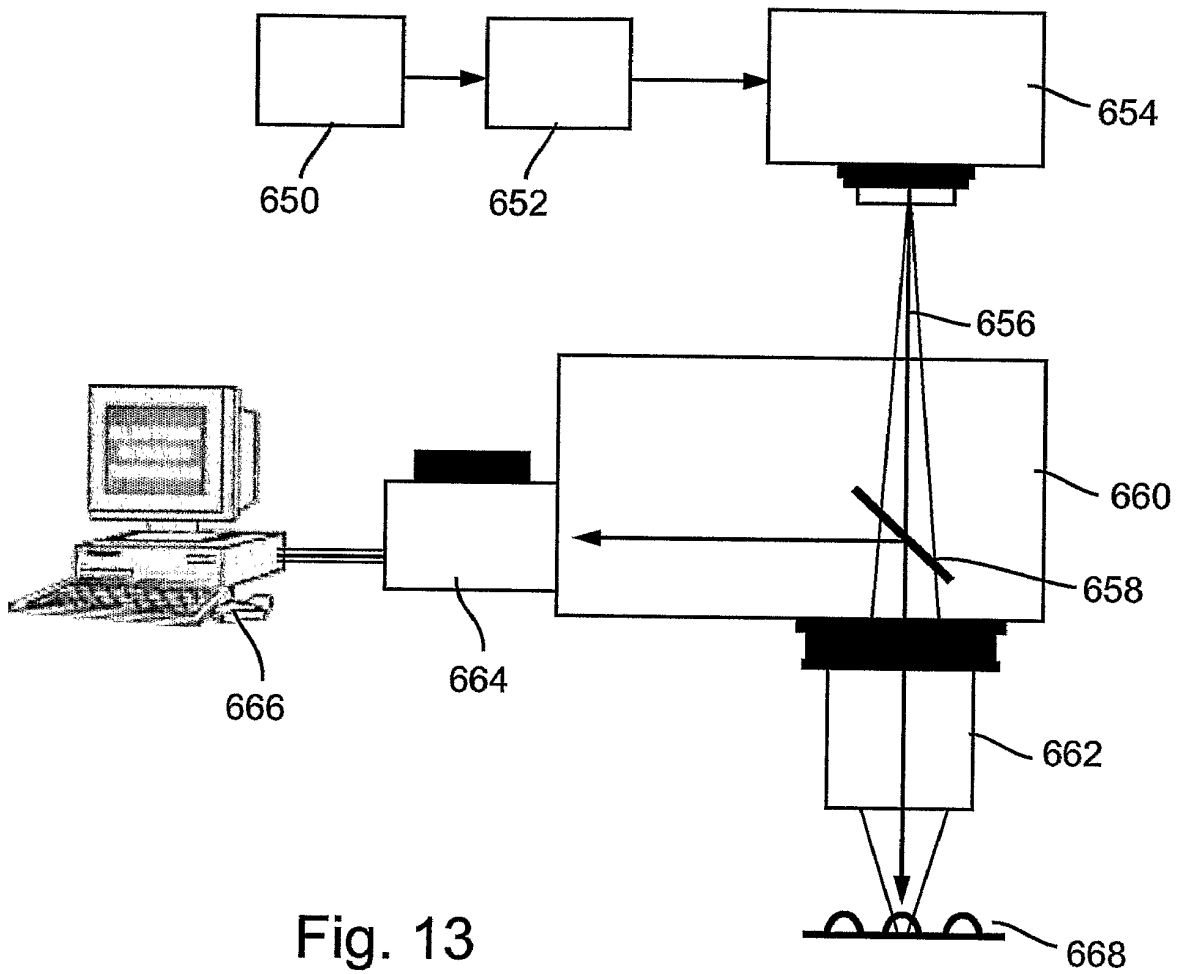

Fig. 13

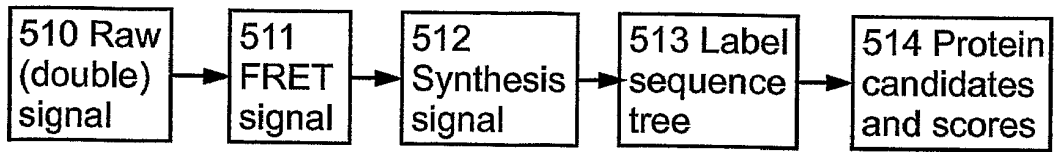

Fig. 14a

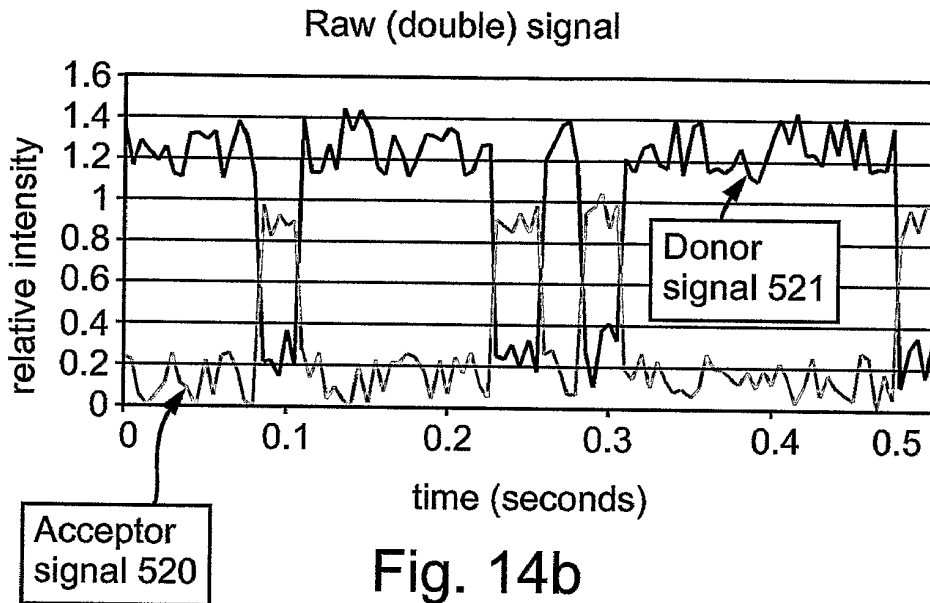

Fig. 14b

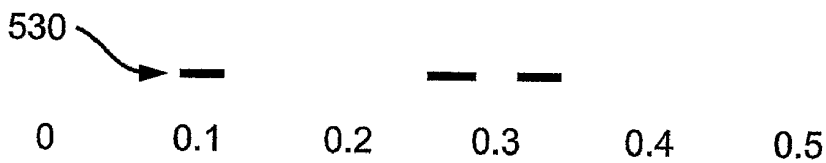

Fig. 14c

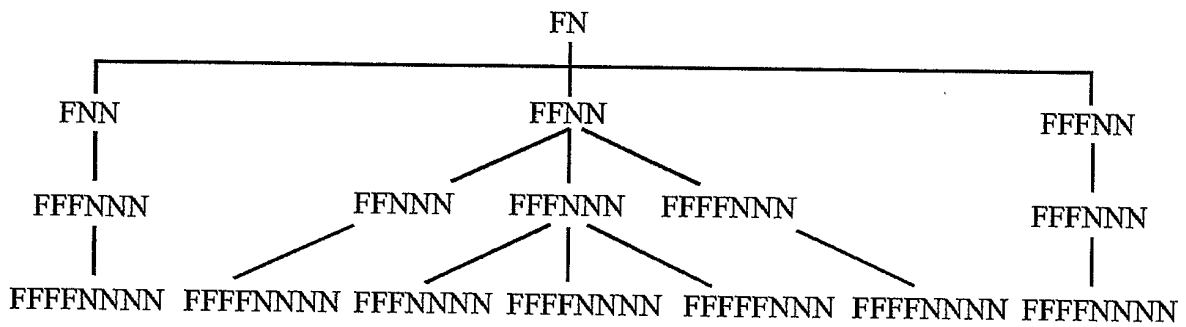

Fig. 14d

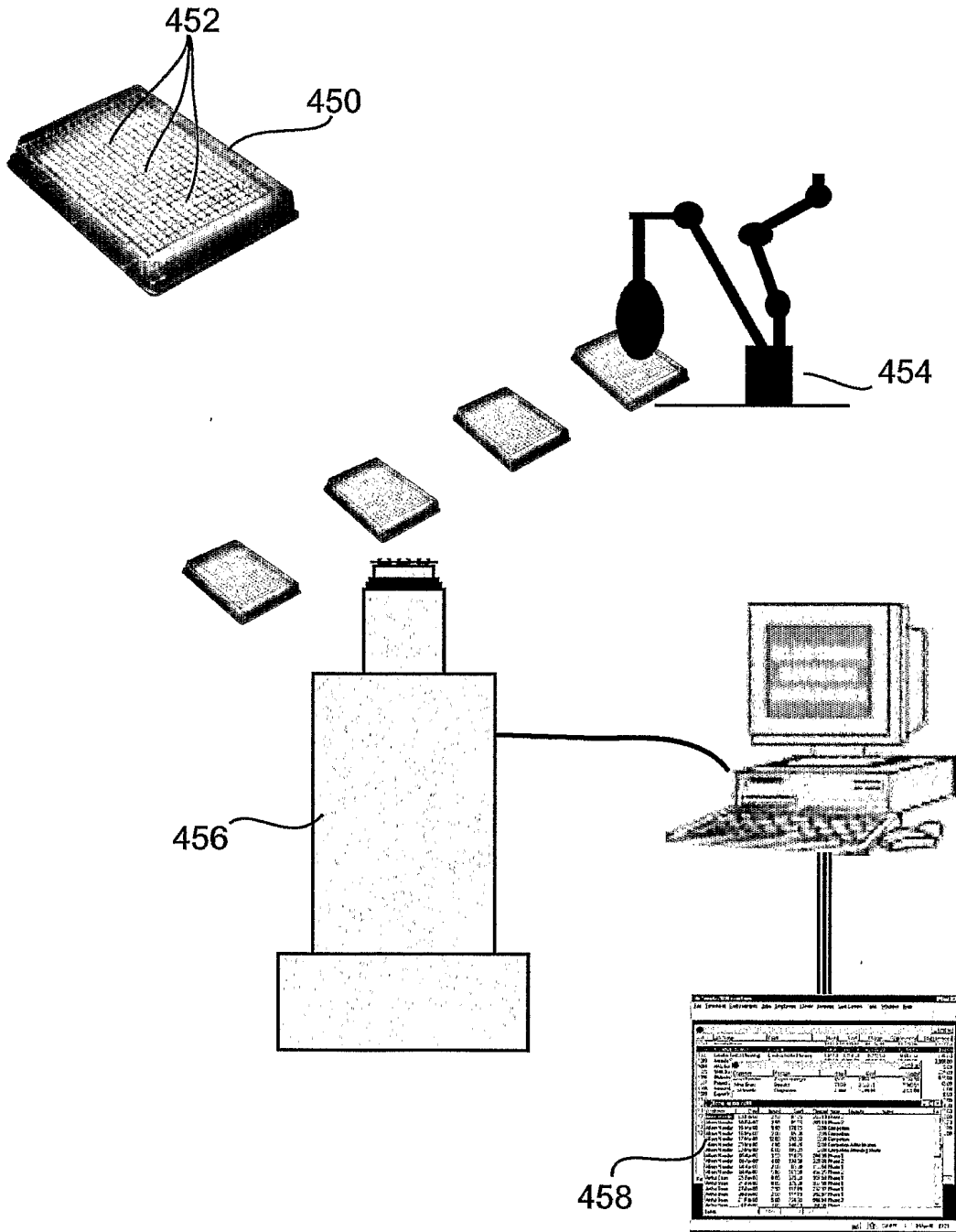

Fig. 15

专利名称(译)	蛋白质合成监测 (PSM)		
公开(公告)号	EP1565566A4	公开(公告)日	2007-04-11
申请号	EP2003775772	申请日	2003-11-27
[标]申请(专利权)人(译)	MEISHAR ^ hžYAZAMUT		
申请(专利权)人(译)	梅哈斯YAZAMUT LTD		
当前申请(专利权)人(译)	梅哈斯YAZAMUT LTD		
[标]发明人	SMILANSKY ZEEV		
发明人	SMILANSKY, ZEEV		
IPC分类号	G01N33/542 B82Y5/00 B82Y10/00 C12Q1/02 G01N33/68 C12Q1/48 C12Q1/34 C12Q1/37 C12Q1/00 C12M1/00 G01N33/53		
CPC分类号	G01N33/6842 B82Y5/00 B82Y10/00 G01N33/542 G01N33/6803		
优先权	60/429532 2002-11-29 US		
其他公开文献	EP1565566B1 EP1565566A2		
外部链接	Espacenet		

摘要(译)

公开了一种用于通过核糖体实时，体内和体外监测蛋白质合成的方法和装置。将核糖体工程化以携带供体荧光团，并且将tRNA和/或氨基酸和/或核糖体的一些其他部分工程化以携带受体荧光团，或者将其天然荧光特性用作受体。当核糖体机制加工mRNA和tRNA分子并合成多肽链时，光源照射核糖体，激发供体荧光团，从而激发受体荧光团，只要它们与供体足够接近。可以将得到的数据制成表格以解释候选药物的活性，阐明细胞蛋白质组学机制，允许蛋白质的受控生产，并且通常提供细胞谜题解决中心的新颖，重要的信息。

41

Table 1: tRNA amino acids

Amino acid	Anticodon sequence	Base at position 8	Amino acid	Anticodon sequence	Base at position 47
Ala	VGC	4	Phe	GAA	X
Cys	GCA	4	Ile	GAU	X
Asp	QUC	4	Ile	JAU	X
Phe	GAA	4	Lys	SUU	X
Gly	CCC	4	Met	MAU	X
His	QUG	4	Arg	ICG	X
Ile	JAU	4	Val	GAC	X
Leu	HAA	4			
Met	MAU	4			
Asn	QUU	4			
Gln	CUG	4			
Gln	NUG	4			
Arg	ICG	4			
Ser	GCU	4			
Ser	GGA	4			
Ser	VGA	4			
Val	GAC	4			
Val	VAC	4			
Trp	CCA	4			
Iln	CAU	4			
Tyr	QUA	4			

A complete database of tRNA sequences can be found in <http://www>