

(19) World Intellectual Property Organization
International Bureau



(43) International Publication Date
3 January 2003 (03.01.2003)

PCT

(10) International Publication Number
WO 03/000116 A2

- (51) International Patent Classification⁷: **A61B**
- (21) International Application Number: PCT/US02/19833
- (22) International Filing Date: 20 June 2002 (20.06.2002)
- (25) Filing Language: English
- (26) Publication Language: English
- (30) Priority Data:
60/299,645 20 June 2001 (20.06.2001) US
- (71) Applicant: MICROVENTION, INC. [US/US]; 72 Argonaut, Aliso Viejo, CA 92656 (US).

- (81) Designated States (*national*): AE, AG, AL, AM, AT, AU, AZ, BA, BB, BG, BR, BY, BZ, CA, CH, CN, CO, CR, CU, CZ, DE, DK, DM, DZ, EC, EE, ES, FI, GB, GD, GE, GH, GM, HR, HU, ID, IL, IN, IS, JP, KE, KG, KP, KR, KZ, LC, LK, LR, LS, LT, LU, LV, MA, MD, MG, MK, MN, MW, MX, MZ, NO, NZ, OM, PH, PL, PT, RO, RU, SD, SE, SG, SI, SK, SL, TJ, TM, TN, TR, TT, TZ, UA, UG, UZ, VN, YU, ZA, ZM, ZW.
- (84) Designated States (*regional*): ARIPO patent (GH, GM, KE, LS, MW, MZ, SD, SL, SZ, TZ, UG, ZM, ZW), Eurasian patent (AM, AZ, BY, KG, KZ, MD, RU, TJ, TM), European patent (AT, BE, CH, CY, DE, DK, ES, FI, FR, GB, GR, IE, IT, LU, MC, NL, PT, SE, TR), OAPI patent (BF, BJ, CF, CG, CI, CM, GA, GN, GQ, GW, ML, MR, NE, SN, TD, TG).

Published:

— without international search report and to be republished upon receipt of that report

For two-letter codes and other abbreviations, refer to the "Guidance Notes on Codes and Abbreviations" appearing at the beginning of each regular issue of the PCT Gazette.

- (72) Inventor: COX, Brian, J.; 3 Novilla, Laguna Niguel, CA 92677 (US).
- (74) Agent: BUYAN, Robert, D.; Stout, Uxa, Buyan & Mullins LLP, 4 Venture, Suite 300, Irvine, CA 92618 (US).

(54) Title: MEDICAL DEVICES HAVING FULL OR PARTIAL POLYMER COATINGS AND THEIR METHODS OF MANUFACTURE

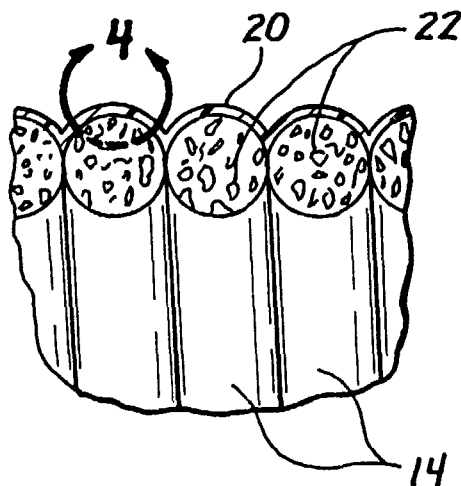

(57) Abstract: Medical devices for insertion into the body of human or veterinary patients, wherein the device comprises a) a working element (e.g. a wire, a guidewire, a tube, a catheter, a cannula, a scope (e.g., rigid or flexible endoscope, laparoscope, sigmoidoscope, cystoscope, etc.) a probe, an apparatus for collecting information from a location within the body (e.g., an electrode, sensor, camera, scope, sample withdrawal apparatus, biopsy or tissue sampling device, etc.) which has an outer surface and b) a continuous or non-continuous coating on the outer surface of the working element. The outer surface of the working element is prepared to create a surface topography which promotes mechanical or frictional engagement of the coating to the working element. In some embodiments the coating is a lubricious coating, such as a fluorocarbon coating or a hydrogel that becomes lubricious when contacted by a liquid. In some embodiments, the coating may expand or swell. Also disclosed are methods for manufacturing such devices.

WO 03/000116 A2

MEDICAL DEVICES HAVING FULL OR PARTIAL POLYMER COATINGS AND THEIR METHODS OF MANUFACTURE

Field of the Invention

5 The present invention relates generally to biomedical devices and methods for manufacturing biomedical devices and more particularly to biomedical devices that have full or partial polymer coatings and their methods of manufacture.

Background of the Invention

10 Medical instruments are frequently coated with various polymers to reduce sliding friction (e.g. by lubricity) and provide other performance enhancing characteristics. Obtaining adequate adherence of the polymer coating to the instrument substrate is a problem in many instances and particularly when a hydrogel is coated on a metal substrate.

15 Various hydrophillic and hydrophobic polymer coatings and their methods of application have been described in United States Patent Nos. 4,263,372 *Method of coating and/or impregnating porous substrates, and products obtained thereby* (Emmons et al.); 4,435,476 *Method of making an abrasion resistant coating on a solid substrate and articles produced thereby* (Phillips et al.); 4,504, 528 *Process for coating aqueous fluoropolymer coating on porous substrate* (Zucker et al.); 4,541,980 *Methods of producing plastic-coated metallic members* (Kiersarsky et al.); 4,705,584 *Application of polymeric materials to substrates* (Lauchenauer); 4,729,914 *Hydrophillic coating and substrate coated therewith* (Kliment et al.); 4,784,159 *Process for making an implantable device having a plasma sprayed metallic porous surface* (Szilagyi);
20 5,095,915 *Guidewire with flexible distal tip* (Engelson); 5,129,890 *Hydrophillically coated flexible wire guide* (Bates et al.); 5,235,964 *Flexible probe apparatus* (Abenaim); 5,290,585 *Lubricious hydrogel coatings* (Elton); 3,969,552 *Process for impregnating porous articles* (Malofsky et al.); 4,147,821 *Impregnation of porous articles* (Young); 4,556,701 *Impregnate compositions for porous substrates* (Schindler et al.); 5,333,620
25 High performance plastic coated medical guidewire (Moutafis et al.); 5,441,488 *Medical tool having lubricious surface in a wetted state and method for production thereof*
30

(Shimura et al.); 5,443,455 *Guidewire and method of pretreating metal surfaces for subsequent polymer coating* (Hergenrother et al.); 5,443,907 *Coating for medical insertion guides* (Slaikou et al.); 5,437,288 *Flexible catheter guidewire* (Schwartz et al.); 5,573,520 *Flexible tubular device for use in medical applications* (Schwartz et al.); 5,749,968 *Device for priming for improved adherence of gels to substrates* (Melanson et al.); 5,750,206 *Method of pretreating metal surfaces for subsequent polymer coating* (Hergenrother et al.); 5,833,632 *Hollow guide wire apparatus catheters* (Jacobsen et al.); 5,700,559 *Durable Hydrophilic Surface Coatings* (Sheu et al.); 6,080,488 *Process for preparation of slippery, tenaciously adhering, hydrophilic polyurethane hydrogel coating...medical devices* (Hostettler et al.); 6,149,978 *Coating of porous, hydrophobic substrates with thermoplastic fluoropolymers* (Bladel et al.); 6,162,310 *Method for producing porous sponge like metal* (Tseng); 6,176,849 *Hydrophilic lubricity coating for medical devices comprising a hydrophobic top coat* (Yang et al.); 5,840,046 *Guidewire Having Hydrophilic Coating* (Deem); 5,984,878 *(Multi-Coating Stainless Steel Guidewire* (Engelson) as well as PCT International Patent Publications WO 92/11877 *Biocompatible abrasion resistant coated substrates* (Fan et al.) and WO 00/65143 *Process for coating a perforated substrate* (Munro et al.), all of which are expressly incorporated herein by reference.

One reason for applying polymer coatings to insertable medical devices is to impart lubricity to, or to lower the coefficient of friction of, the outer surface of the device. Some of these polymer coatings, such as fluorocarbon coatings (e.g., polytetrafluoroethylene) provide a lubricious hydrophobic surface while others such as swellable hydrogels are hydrophilic and become lubricious after coming in contact with liquid (e.g., blood or other body fluid).

For example, United States Patent No. 5,573,520 (Schwartz et al.) describes a flexible tubular member encased by a fluid tight polymer covering, including a hydrogel, for use as a guidewire, catheter or introducer. However, the polymer covering is only described as covering either the inside surface or the outside surface for the purposes of a fluid tight sealing of apertures or for providing lubricity. As described earlier, these benefits of coatings are known in the art. However, Schwartz et al. does not describe

the coating to be integral to the wall of the device or there being any sort of interlock or other improved attachment of the coating.

Also, United States Patent No. 5,840,046 (Deem) describes guidewires having hydrophilic coatings, such as hydrophilic polysaccharides (e.g., hyaluronic acid or chondroitin sulfate). The guidewires are made of wire which is helically coiled about a core member. The spacing between adjacent coils of the wire is wide enough to allow the coating to flex along with the coil but narrow enough to prevent the coating from penetrating into an annular space that exists between the coiled wire and the inner core member.

Summary of the Invention

The present invention provides novel polymer coated medical instruments including guidewires, catheters, cannula, endoscopes and other instruments for insertion into the body.

In accordance with the present invention, there are provided medical devices that are insertable into the bodies of human or veterinary patients, each such device comprising a) a working element having an outer surface and b) a polymer coating disposed on at least a portion of the outer surface of the working element, wherein the outer surface of the working element has a topography characterized by surface features which deter longitudinal slippage of the coating over the outer surface and or which result in some mechanical engagement or interlock between coating and the working element. In this regard, the outer surface of the working element may have one or more cavities formed therein, at least some of those cavities having side walls which are disposed at angles of about 75 or more degrees relative to the longitudinal axis of the working element (or relative to the outer surface of the working element immediately adjacent to those side walls) and wherein at least a portion of the polymer coating extends into at least some of the cavities so as to deter separation of the polymer coating from the working element. In this manner the present invention may provide an alternative to the use of adhesive coatings or chemical adhesive layers such

as the "tie layers" described in United States Patent 5,749,837 (Palermo), which is expressly incorporated herein by reference.

Further in accordance with the invention, the cavities formed in the outer surface of the working element may comprise holes, grooves, a continuous helical or curved groove, slots, pores, apertures or other external surface features to provide a substantial improvement in the adherence of a polymer coating. The coating fills into at least some of the cavities to form a mechanical bond or interlock with the working element. To accomplish such mechanical bond or interlock, the cavities are preferably at least about .001 inch deep and may extend completely through the working element forming a through-hole or slot. In at least some embodiments, it is preferable that the polymer coating to penetrate to a depth below the outer surface that is at least about 25%, and more preferably at least about 50%, of the total thickness of the polymer coating on that portion of the device. Thus, for example, in a region where the polymer coating is a total of 100 mills thick, it will be preferable for the coating to penetrate into cavities at least about 25 mills below the outer surface and more preferably at about 50 mills below the outer surface. The coating need not be for the purpose of providing lubricity, although such is one purpose for the invention. Indeed, the coating may serve any purpose, such as the creating of a biocompatible barrier to insulate the patients body from toxic, infectious or non-biocompatible materials on the underlying surface of or within the device.

Still further in accordance with the invention the working element may comprise any apparatus or device that is insertable into the body, including but not limited to a wire, a guidewire, a tube, a catheter, a cannula, a scope (e.g., rigid or flexible endoscope, laparoscope, sigmoidoscope, cystoscope, etc.) a probe, an apparatus for collecting information from a location within the body (e.g., an electrode, sensor, camera, scope, sample withdrawal apparatus, biopsy or tissue sampling device, etc.). The working element's outer surface may be made from a radiopaque, biocompatible metal such as platinum, gold, tungsten, nitinol, elgiloy, stainless steel, or tantalum but may be made of a polymer impregnated or otherwise modified to be visible under x-rays by various means known in the art. Alternatively, the working element's outer surface

may be made of a plastic or polymer material which, in at least some embodiments, may be visualized under ultrasound, magnetic resonance imaging, radiographic imaging or other medical visualization methods known in the art.

5 Still further in accordance with the present invention, the polymer coating may comprise a material that is lubricious or has a low coefficient of friction, such as polytetrafluoroethylene (e.g. Teflon). Also, the polymer coating may comprise a hydrophilic polymer (i.e. hydrogel) that creates a lubricious surface after being exposed to a liquid (e.g., blood or other body fluid). It is preferable that the hydrogel be polymerized from ethylenically unsaturated monomers. In some cases, environmentally
10 responsive hydrogels may be used such as that described in copending United States Patent Application Serial No. 09/804,935 entitled *Hydrogels That undergo Volumetric Expansion In Response To Changes In Their Environment And Their Methods Of manufacture And Use*. Specific examples of hydrogels that may be used include those described in U.S. Patents 4,729,914 (Kliment), 5,290,585 (Eiton), 5,331,027
15 (Whitbourne), 6,080,488 (Hostettler et al.), 6,176,849 (Yang et al.) and pending United States Patent Application Serial No. 09/804,935 entitled *Hydrogels That undergo Volumetric Expansion In Response To Changes In Their Environment And Their Methods Of manufacture And Use*, each of which is expressly incorporated herein by reference. In some embodiments of the invention, the polymer may be formed about
20 the outer surface of the working element in a non-continuous manner (e.g., in discrete ridges, bumps or areas) or such polymer coating may be disposed in a manner that forms a generally smooth continuous polymer coating surface. In some embodiments, the polymer coating may be radiopaque.

25 Even further aspects of this invention will be come apparent to those of skill in the art upon reading of the detailed description of exemplary embodiments set forth herebelow.

Brief Description of the Drawings

Figure 1 is a perspective view of a guidewire which has a polymer coating disposed thereon in accordance with the present invention.

Figure 2 is an enlarges, cut-away view of portion 2 of the guidewire of Figure 1.

Figure 3 is an enlarged view of portion 3 of Figure 2.

Figure 4 is an enlarged view of portion 4 of Figure 3.

5 Figure 5 is a partial longitudinal sectional view of another guidewire which has a polymer coating disposed thereon in accordance with the present invention.

Figure 6 is a partial longitudinal sectional view of a solid, elongate probe which has a polymer coating disposed thereon in accordance with the present invention.

10 Figure 7 is a partial longitudinal sectional view of an elongate tubular device such as a catheter, scope, cannula, introducer, sheath, or the like having a polymer coating disposed thereon in accordance with the present invention.

Figure 8 is a partial longitudinal sectional view of an elongate device having another polymer coating disposed thereon in accordance with the present invention.

Figures 9a-9d show, in step by step fashion, a method for manufacturing a device having a polymer coating disposed thereon in the manner shown in Figure 8.

15 Detailed Description of the Invention

The invention is described herebelow with reference to certain examples or embodiments as shown in the accompanying drawings. These examples or embodiments are not limiting, but rather are merely exemplary of some of the ways in which the present invention may be reduced to practice.

20 Figures 1-4 show an example of a guidewire 10 that bears a polymer coating according to this invention. As shown, the guidewire 10 comprises an elongate, flexible body 12 having a blunt distal tip member 18 positioned at its distal end. The guidewire body 12 comprises a continuous, tightly wound, helical coil formed of wire 14. A solid or tubular core member 16 may optionally be disposed within the helically wound wire
25 14. Pores 22 are formed in at least the outer surface of the helically coiled wire 14. A

polymer coating 20 is disposed on the outer surface of the guidewire body 12, as shown. A portion of such polymer coating extends into some of the pores 22 at the surface of the wire 14, as can be appreciated from the showing of Figure 4. The wire 14 is made of a porous material or is treated to have a porous surface. If a porous material is used, secondary cutting or surface treatment of the wire 14 may be avoided or reduced. Microporous metal can be fabricated by sintering process, plasma spraying (see U.S. Patent 4, 784,159) or other means known in the art. One biologically compatible, porous, sintered metal is commercially available from Implex Corp., Allendale, NJ under the tradename Hedrocel.[®] In the device shown in Figures 1-4, the coating 20 has impregnated the pores 22 of the wire 14 to form a mechanical bond. One example of an acceptable coating is a fluoropolymer coating and applied by the methods described by Bladel et al. in the U.S. Patent 6,149,978. Another example of an acceptable coating is a swellable hydrogel. Optionally, the coating may be modified, impregnated or otherwise combined with a variety of pharmacologic or bioactive substances (e.g. chemicals, drugs, proteins, peptides, or growth factors) to impart anti-infective, anti-thrombogenic or other desirable interactions with the body.

Although the example shown in Figures 1-4 is a guidewire 10, it is to be appreciated that the working element on which the coating 20 is applied may comprise any insertable medical device, including but not limited to a catheter, cannula, probe, scope, electrode, other wire, sensor, etc.

As shown in Figures 2 and 4, it will be further appreciated that, in at least some embodiments of the invention (e.g., guidewires, scopes, catheters, other elongate devices that are insertable and retractable into and out of the body), the medical device will have a longitudinal axis LA along which the device is typically advanced and retracted. A wall axis WA projected parallel to a portion of a wall of a cavity 20 (e.g., slot, pore, groove, aperture or other opening or depression) within which the polymer is deposited may be perpendicular, nearly perpendicular or non-parallel to the longitudinal axis, as shown. Preferably, the angle A between the longitudinal axis LA and wall axis WA will be at least 75 degrees and preferably at least 90 degrees. In cases where the angle A is greater than 90 degrees, an undercut will be created and

such undercut will create a firm mechanical interlock between the coating 20 and the surface of the working element (e.g., the body 12 of the guidewire, Catheter, scope, probe, wire, electrode, sensor, etc.). In these embodiments, any slippage or separation of the polymer coating 20 from the device 10 would require the polymer coating 20 to move outwardly along the wall axis WA in order for the coating 20 to pull out of the cavities 22 into which it is deposited. Since this wall axis WA is non-parallel to the longitudinal axis of the device, routine advancement and retraction of the device along its longitudinal axis will not facilitate unwanted slippage or movement of the polymer in the direction of the wall axis and the penetration or extension of the coating 20 into the cavities 22 will reduce the potential for unwanted longitudinal slippage or separation of the polymer coating 20 from the device 10 as the device 10 is routinely advanced into and retracted from the patient's body.

Variations of the working element and/or variations in the types of cavities formed in its surface are shown in Figures 5-8. Specifically, Figure 5 shows a section of another guidewire 30 which comprises a helically wound coil of relatively non-porous steel wire 32 having a polymer coating 34 disposed on the outer surface 38 thereof. An optional tubular core member 36 is positioned within the coiled wire 32. The outer surface 38 of the wire 32 has been treated by a mechanical abrasion process or chemical etching by an acid or other chemical which results in microtexturing of the outer surface, as shown. This microtextured outer surface 38 has cavities 39 (e.g., indentations, pits, depressions, grooves, a single helical or curved groove, etc.) formed therein. The coating 34 has entered some or all of the cavities 39, thereby creating a mechanical interlock between the outer surface 38 of the device 30 and the coating 34.

Figure 6 shows a substantially solid member 42, such as a probe or scope, which has generally rectangular cavities in the nature of slots 46 formed inwardly from the outer surface 47 thereof. A polymer coating 44 is disposed continuously over the outer surface 47 of the solid member 42. A longitudinal axis LA is projectable through the solid member 42. A wall axis WA is projectable along the side wall 48 of each slot 46. For at least some of the slots 46, the wall axis WA is substantially perpendicular to the longitudinal axis LA, such that angle A will be approximately 90 degrees, as

shown in Figure 6. It will be appreciated that, in some embodiments, the side walls 48 of at least some slots 46 may be slanted or angled such that the slot 46 is wider at its bottom B than at its top T, thereby creating an undercut which further mechanically locks or frictionally engages the coating 44 to the solid member 42.

5 Figure 7 shows yet another example of the present invention. In the example of Figure 7, the working element of the device comprises a tubular catheter or cannula 50. A metal tube 53 which has slots or holes 58 formed therein is used as a backbone for the catheter or cannula 50. A mandrel or other space occupying member (not shown) is placed within the area of the lumen 56 and a polymer coating 54 is applied
10 such that the polymer coating 54 permeates through the slots 58 and into contact with the mandrel or other space occupying member. After the coating has solidified, the mandrel or other space occupying member is removed to create the lumen 56. The polymer coating 54 thus creates a continuous sidewall of the tubular catheter or cannula 50 with the slotted metal tube 52 forming a backbone, skeleton or scaffold for
15 the polymer coating.

 Figure 8 shows yet another example of the present invention. In the example of Figure 8, the working element of the device 60 comprises a tubular catheter body 62 formed of a plastic material and having a lumen 66 extending longitudinally therethrough. Cavities 68, in the nature of blind bore holes, slots or groves, extend
20 downwardly from the outer surface 69 of the catheter body 62 but do not penetrate into the lumen 66. Quantities of coating 64 are deposited in each cavity 62 and protrude upwardly above the outer surface of the catheter 69. The quantities of coating 64 may be discreet and unconnected to one another, as shown in Figure 8, to thereby form a non-continuous coating comprising a system of raised knobs, bumps, ridges, etc. The
25 coating 64 may be deposited into the cavities 68 so that a meniscus or heap of coating 64 protrudes out of the top of each cavity 68. Alternatively, the coating 64 may be a swellable or expandable coating such as a hydrophilic material (e.g., a hydrogel) and such coating 64 may be initially deposited within each cavity 62 such that the top surface of the coating 64 is flush with or below the adjacent outer surface 69 of the
30 catheter body 62 and such coating 64 may subsequently swell or expand such that it

will protrude upwardly above the adjacent outer surface 69, as desired. Such swelling or expansion may, in some embodiments, occur when the coating 64 is in contact with a liquid or body fluid for sufficient time to cause the desired swelling or expansion of the coating 64.

5 Figures 9a-9d show, in step by step fashion, a method for manufacturing a device having non-continuous, discrete deposits of a polymer coating, such as the device 60 of Figure 8. In this method, a working element such as a wire, a guidewire, a tube, a catheter, a cannula, a scope (e.g., rigid or flexible endoscope, laparoscope, sigmoidoscope, cystoscope, etc.) a probe, an apparatus for collecting information from
10 a location within the body (e.g., an electrode, sensor, camera, scope, sample withdrawal apparatus, biopsy or tissue sampling device, etc.) formed of any suitable material such as metal or plastic is initially provided as shown in Figure 9a. A plurality of cavities 66 such as blind bore holes, slots, indentations, depressions, cuts, grooves, etc. are formed in the outer surface 62 of the working element 62. This may be
15 accomplished by any technique known in the art such as mechanical drilling, boring, laser etching, cutting, EDM, photochemical etching, etc. As shown in Figure 9b, wall axes WA projected parallel to at least portions of the sidewalls 65 of at least some of the cavities 66 preferably form an angle A relative to the longitudinal axis LA of the working element or a longitudinal axis of the working element's outer surface 63 are preferably greater than 75 degrees and more preferably greater than 90 degrees. In
20 some embodiments, as shown in Figure 9b (alt) the sidewalls 65a of the cavities 66a may be angled or curved such that the cavities 66a are wider at their bases B than at their tops T. This results in the formation of an angle A greater than 90 degrees and forms an undercut whereby the later-applied coating 64 (Figures 9c-9d) becomes
25 mechanically or frictionally interlocked or engaged by the sidewalls 65a of the cavities 66a.

After the cavities 66 or 66a have been formed in the working element 65, polymer coating 64 is deposited in the cavities 66 or 66a. In some embodiments, such as the specific example shown in Figures 9c-9d, the coating 64 is a swellable or
30 expandable coating 64 which swells or expands after coming in contact with a body

fluid BF such as blood or other liquid such as saline solution or sterile water. The coating 64 may be initially applied over the entire outer surface 66 of the working element 62 and the layer of coating deposited on the outer surface may then be wiped or scraped away, or otherwise removed, leaving discrete deposits of coating 64 within the cavities 66 such that the upper surface 64_{us} of each mass of coating 64 is substantially flush with or even slightly below the level of the outer surface 66.

Thereafter, when the working element 62 is immersed in blood or other body fluid BF or when it is immersed in or contacted by a liquid (saline, water, etc.), the deposits of polymer coating 64 will expand or swells such that the upper surface US of each coating deposit 64 protrudes above the outer surface 66 of the working element 62. Alternatively, the polymer coating may expand in response to changes in its environment, such as changes in pH. In this manner, the expansion of the polymer coating creates a non-continuous coating system which comprises discrete raised knobs, bumps, ridges, etc. of polymer coating 64, on the outer surface 66 of the working element 62. Such coating 64 may impart lubricity or form a slippery substance which facilitates the desired insertion, positioning, movement and/or withdrawal of the working element 62 from the body of a human or veterinary patient.

The invention has been described herein with reference to certain examples and embodiments only. No effort has been made to exhaustively describe all possible examples and embodiments of the invention. Indeed, those of skill in the art will appreciate that various additions, deletions, modifications and other changes may be made to the above-described examples and embodiments, without departing from the intended spirit and scope of the invention as recited in the following claims. For example, the particular elements and attributes of any particular embodiment or example may be combined with or substituted for elements or attributes of any other embodiment wherever such addition or substitution does not render the resultant device unuseable or unsuitable for its intended application. Also, although specific types of coating have been referred to herein, many other types of lubricious, non-lubricious, hydrophilic and/or hydrophobic coatings may be used in devices of this invention.

Accordingly, it is intended that all such additions, deletions, modifications and other changes be included within the scope of the following claims.

Claims

What is claimed is:

- 1 1. A medical device that is insertable into the body of a human or veterinary patient,
2 said device comprising:
- 3 a working element having an outer surface;
- 4 a polymer coating disposed on at least a portion of the outer surface of the working
5 element;
- 6 the outer surface of said working element having cavities formed therein, at least some
7 of said cavities having side walls which are disposed at angles of about 75 or more
8 degrees relative to the outer surface of the working element immediately adjacent to
9 side walls; and,
- 10 at least a portion of said polymer coating extending into said cavities so as to deter
11 separation of the polymer coating from the working element.
- 1 2. A device according to Claim 1 wherein the working element comprises a catheter
2 or cannula.
- 1 3. A device according to Claim 1 wherein the working element comprises a
2 guidewire.
- 1 4. A device according to Claim 1 wherein the working element comprises a
2 scope.

1 5. A device according to Claim 1 wherein the working element comprises an
2 apparatus for obtaining information from a location within the patient's body.

1 6. A device according to Claim 1 wherein the polymer coating is lubricious.

1 7. A device according to Claim 1 wherein the polymer coating becomes
2 lubricious upon contact with a liquid.

1 8. A device according to Claim 1 wherein the polymer coating comprises a
2 hydrogel.

1 9. A device according to Claim 1 wherein the polymer coating comprises a
2 porous hydrogel.

1 10. A device according to Claim 1 wherein the polymer coating expands in the
2 presence of liquid.

1 11. A device according to Claim 1 wherein the cavities formed in the outer
2 surface of the working element comprise pores.

1 12. A device according to Claim 1 wherein the cavities formed in the outer
2 surface of the working element comprise grooves.

1 13. A device according to Claim 1 wherein the cavities formed in the outer
2 surface of the working element comprise depressions.

1 14. A device according to Claim 1 wherein the cavities formed in the outer
2 surface of the working element comprise indentations.

1 15. A device according to Claim 1 wherein the cavities formed in the outer
2 surface of the working element comprise holes.

1 16. A device according to Claim 1 wherein the cavities formed in the outer
2 surface of the working element comprise slots.

1 17. A device according to Claim 1 wherein the cavities formed in the outer
2 surface of the working element extend only partially into the working element.

1 18. A device according to Claim 1 wherein the cavities formed in the outer
2 surface of the working element extend through the working element.

1 19. A device according to Claim 1 wherein the porosity of the polymer coating
2 is at least about 50%.

1 20. A device according to Claim 1 wherein the polymer coating extends into
2 cavities at least 0.001 inch below the outer surface.

1 21. A device according to Claim 1 wherein the polymer coating extends into
2 cavities such that the polymer coating extends to a depth below the outer surface that
3 is at least about 25% of the total thickness of the polymer coating at that location.

1 22. A device according to Claim 21 wherein the porosity of the polymer
2 coating, when substantially fully expanded, is between about 50% and about 95%.

1 23. A device according to Claim 1 wherein substantially all of the polymer
2 coating is initially contained within the cavities and such polymer coating subsequently
3 expands such that a portion of said polymer coating protrudes out of the cavities.

1 24. A device according to Claim 1 wherein substantially all of the polymer
2 coating is initially contained within the cavities beneath the outer surface and such
3 polymer coating subsequently expands such that a portion of said polymer coating
4 protrudes out of the cavities and above the outer surface.

1 25. A device according to Claim 1 wherein the polymer coating comprises a
2 fluorocarbon.

1 26. A device according to Claim 1 wherein the polymer coating comprises
2 polytetrafluoroethylene.

1 27. A device according to Claim 1 wherein the angle is at least 90 degrees.

1 28 A device according to Claim 1 wherein the angle is greater than 90
2 degrees thereby creating an undercut surface.

1 29. A device according to Claim 1 wherein the polymer coating expands when
2 in contact with a liquid.

1 30. A device according to Claim 1 wherein the polymer coating comprises a
2 hydrogel that expands when in contact with a liquid.

1 31. A method for manufacturing a coated medical device which comprises a
2 working part having an outer surface and a longitudinal axis, said working part being
3 insertable into the body of a human or veterinary patient, said method comprising the
4 steps of:

5 (A) treating at least a portion of the outer surface to create a surface
6 topography which includes cavities; and,

7 (B) applying a polymer coating to the outer surface such that the surface
8 topography deters separation of the coating from the outer surface.

1 32. A method according to Claim 31 wherein Step A comprises forming cavities at
2 least 0.001 inch into the outer surface.

1 33. A method according to Claim 31 wherein Step A comprises forming a continuous
2 depression in the outer surface.

1 34. A method according to Claim 33 wherein the continuous depression comprises
2 a helical groove.

1 35. A method according to Claim 32 wherein Step A comprises forming undercut
2 cavities in the outer surface.

1 36. A method according to Claim 31 wherein Step B comprises applying a lubricious
2 coating.

1 37. A method according to Claim 31 wherein Step B comprises applying a non-
2 lubricious coating.

1 38. A method according to Claim 31 wherein Step B comprises applying an
2 expandable coating.

1 39. A method according to Claim 38 wherein Step B comprises applying a coating
2 that expands when in contact with a liquid.

1 40. A method according to Claim 31 wherein Step B comprises applying a coating
2 that expands in response to a change in its environment.

1 41. A method according to Claim 40 wherein Step B comprises applying a coating
2 that expands in response to a change in the pH of its environment .

1 42. A method according to Claim 31 wherein Step A comprises creating cavities in
2 the outer surface.

1 43. A method according to Claim 41 wherein Step B comprises applying the polymer
2 coating such that the coating extends into cavities to a depth below the outer surface
3 that is at least about 25% of the total thickness of the polymer coating at that location
4 on the device.

1 44. A method according to Claim 31 wherein Step B comprises applying the polymer
2 coating such that the polymer coating extends to a depth of at least 0.001 inch below
the plane of the outer surface.

1/3

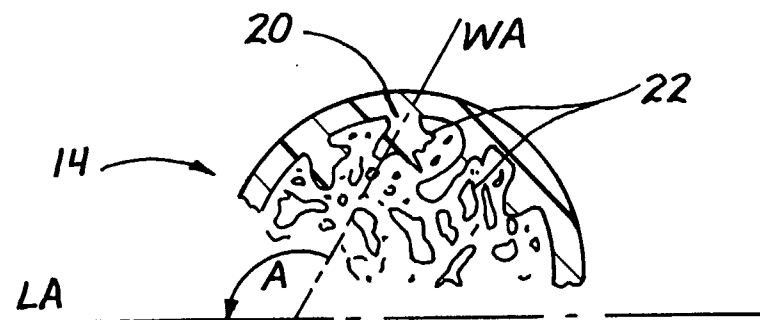
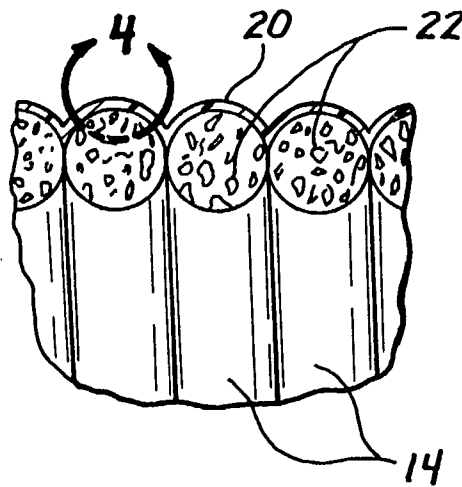
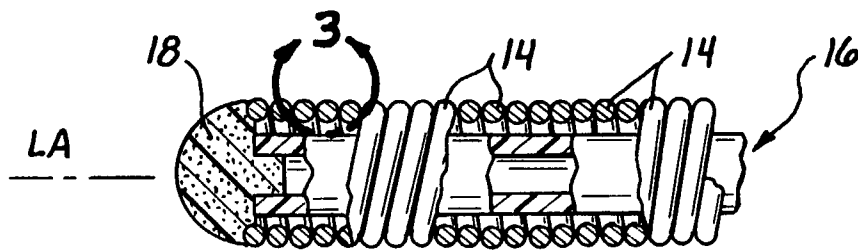
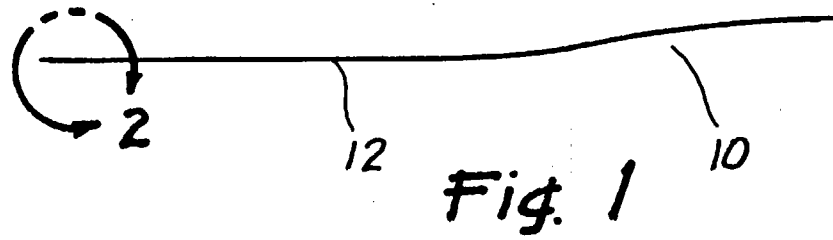

2/3

Fig. 5

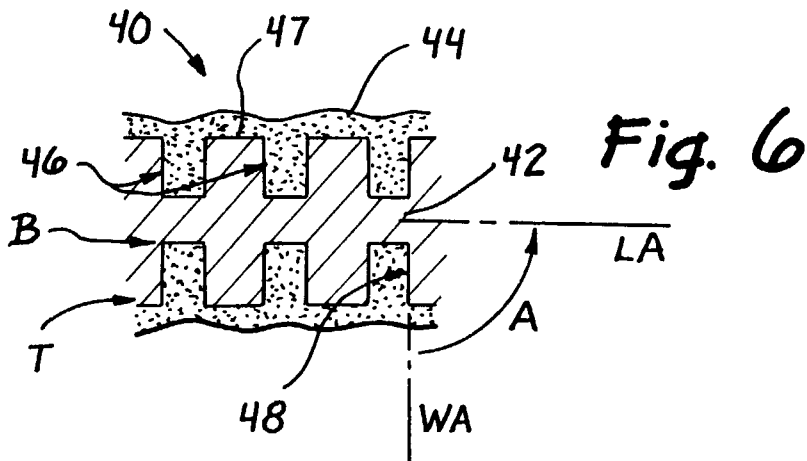
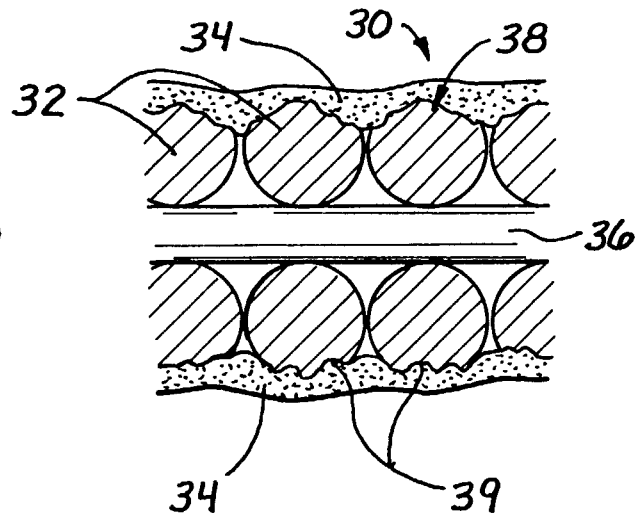

Fig. 6

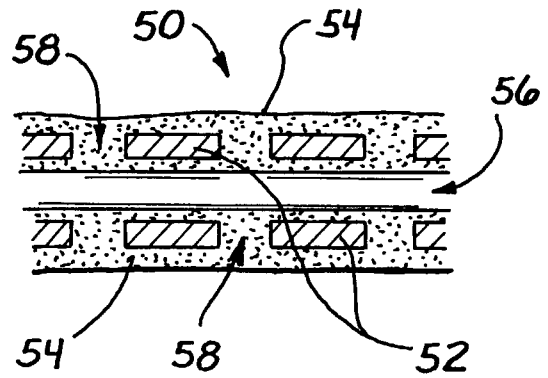

Fig. 7

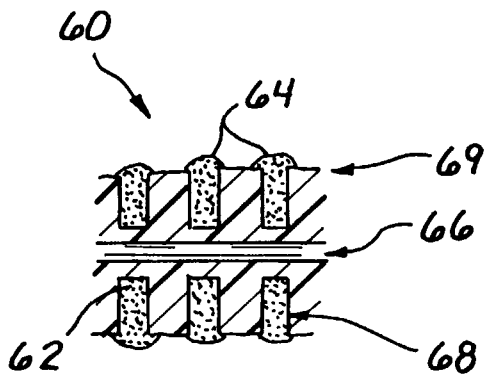

Fig. 8

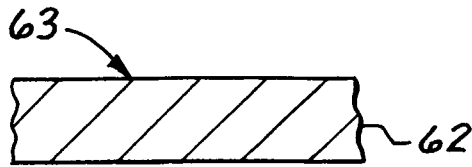

Fig. 9A

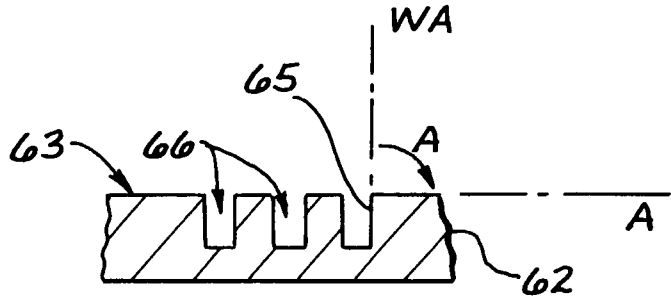

Fig. 9B

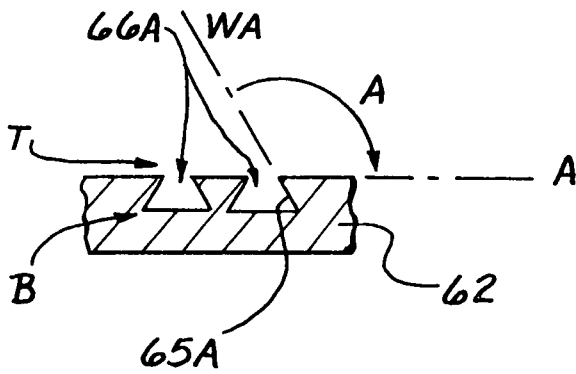

Fig. 9B(ALT)

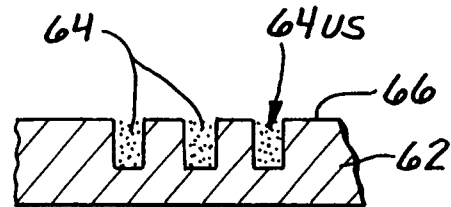

Fig. 9C

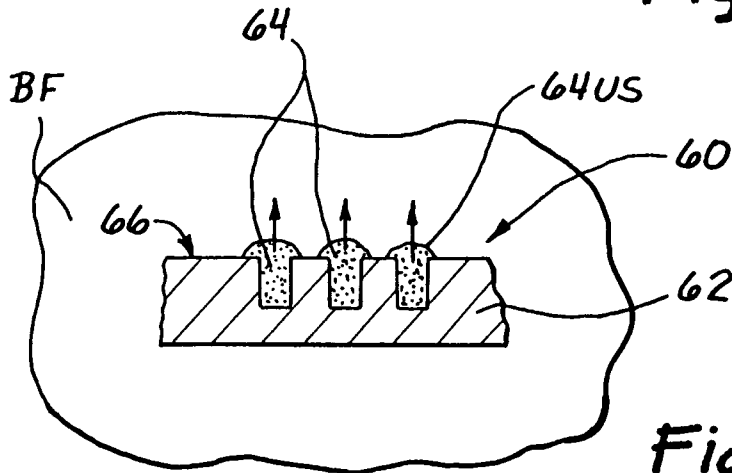

Fig. 9D

专利名称(译)	具有全部或部分聚合物涂层的医疗装置及其制造方法		
公开(公告)号	EP1406536A2	公开(公告)日	2004-04-14
申请号	EP2002744542	申请日	2002-06-20
[标]申请(专利权)人(译)	微温森公司		
申请(专利权)人(译)	MicroVention公司, INC.		
当前申请(专利权)人(译)	MicroVention公司, INC.		
[标]发明人	COX BRIAN J		
发明人	COX, BRIAN, J.		
IPC分类号	A61B1/00 A61L29/08 A61M25/00 A61M25/01 A61B5/00		
CPC分类号	A61L29/085 A61M25/0045 A61M25/09 A61M2025/0046 A61M2025/09091 A61M2025/09108		
代理机构(译)	科茨IAN HAROLD		
优先权	60/299645 2001-06-20 US		
其他公开文献	EP1406536A4		
外部链接	Espacenet		

摘要(译)

用于插入人或兽医患者体内的医疗装置(10),其中该装置包括a)工作元件(12)(例如导线,导丝,管,导管,套管,示波器(例如刚性的)或者是柔性内窥镜,腹腔镜,乙状结肠镜,膀胱镜等)探头,用于从身体内的位置收集信息的装置(例如,电极,传感器,照相机,示波器,取样装置,活组织检查或组织取样装置等)。)具有外表面和b)在工作元件的外表面上的连续或不连续的涂层(20)。制备工作元件(12)的外表面以产生表面形貌(22),其促进涂层(20)与工作元件(12)的机械或摩擦接合。在一些实施方案中,涂层是润滑涂层(20),例如碳氟化合物涂层或水凝胶,当与液体接触时变得润滑。在一些实施方案中,涂层(20)可以膨胀或膨胀。还公开了制造这种装置的方法。