

(19)
(12)

(KR)
(B1)

(51) 。 Int. Cl.⁷
A61B 8/00

(45)
(11)
(24)

2003 06 25
10-0388407
2003 06 09

(21) 10-2001-0022831
(22) 2001 04 27

(65)
(43)

2002-0083321
2002 11 02

(73)

114

(72)

120 1002

6-3

105 1403

(74)

:

(54)

3

(voxel)

(echo)

3

3

. 3

RF

, RF

(set)

, 3

3

3

, 3

(display)

5

3

,

, RF

,

(voxel),

1

3

.

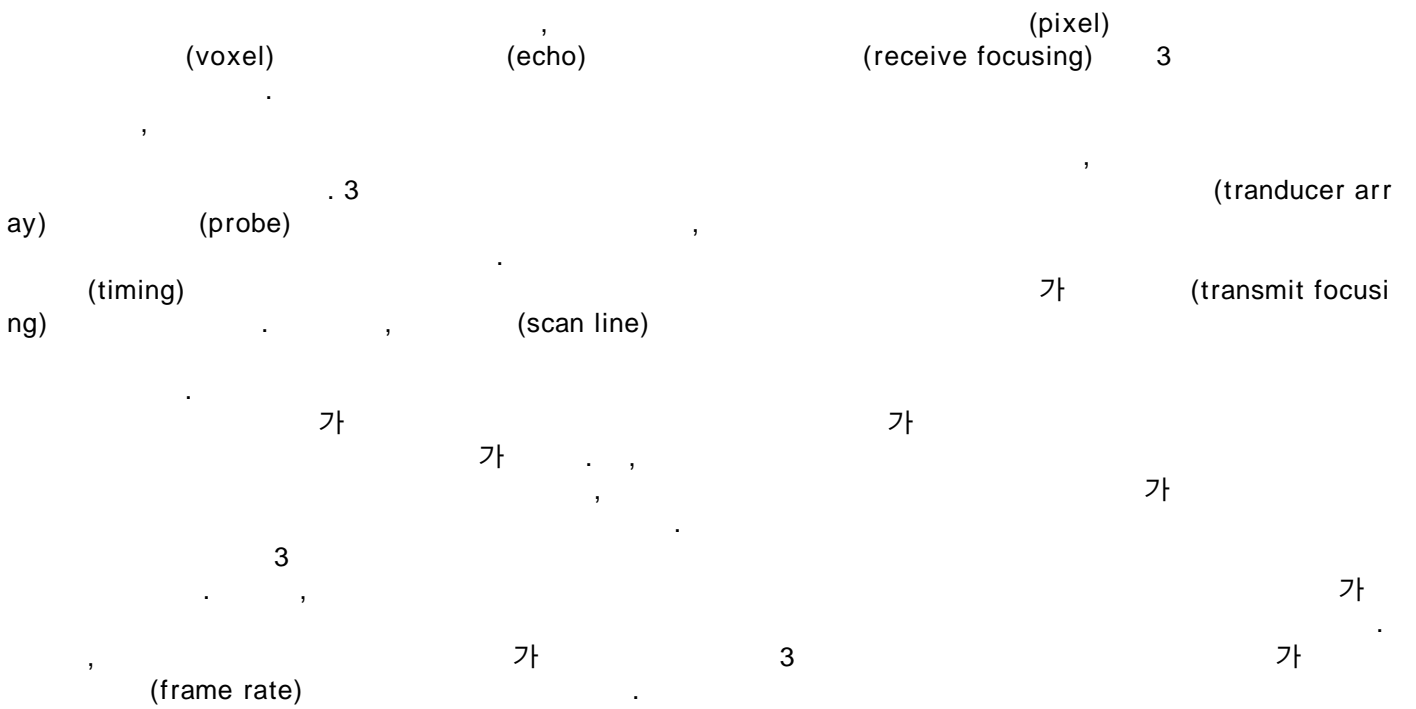
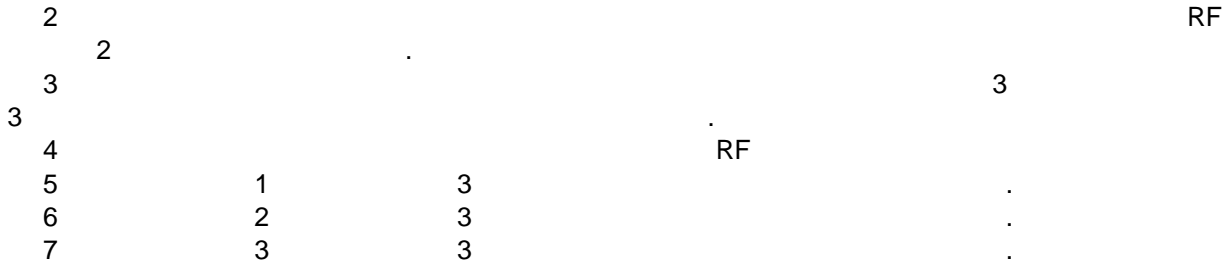

$$\frac{1}{FR} = \frac{2D}{c} \times N$$

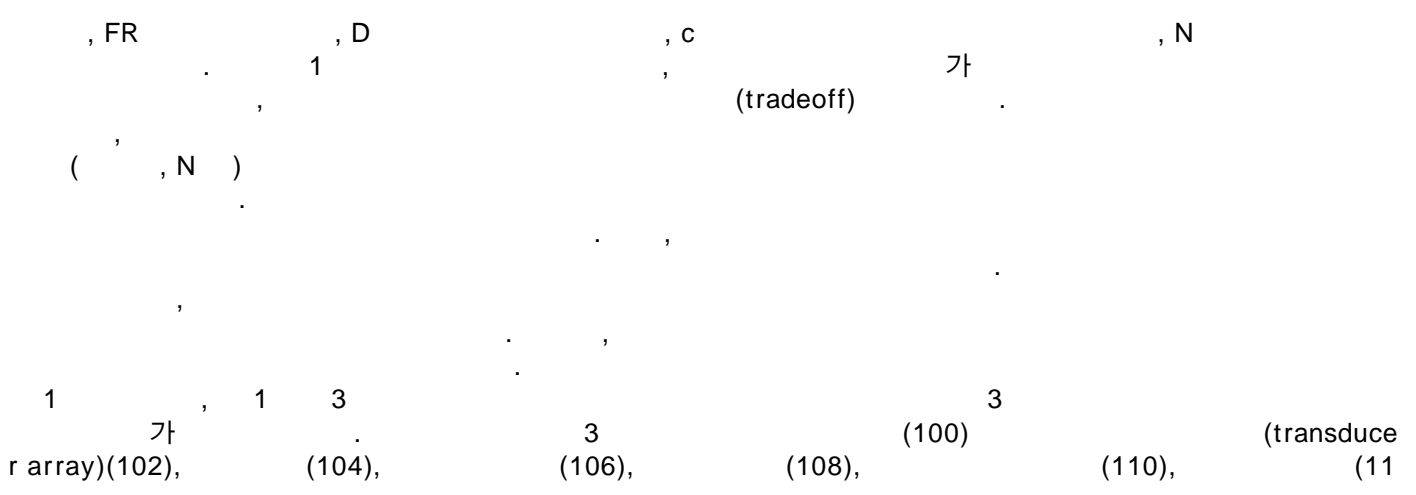

2), (114) (108) , (104) (106) (102)

(104) (102) RF

(106), (108), (110) 3 3

가 (114) (pixel) (114) (1

(112) 3 (114) RF (110)

14) 1 (110) (horizontal raster line display format) (114) 3

(114) 3 R- 가 (interpolation)

(110) (110) 3 가 3 3 (112) 3

(112) (114) (110) 3) (110) 3

(110) 3 2 2 3 ,

3 3 (distortion)

3 3

RF 3 , RF 3 (display) 3

3 3

2 7 3 2 RF

가 2 2 (scan line) I(x,y,z)

3 2 가 , I(x,y,z)

2 3 , I(x,y

,z) 3 (set) I(x,y

3 I(x,y,z) 3 N R(m)

m), max , D(mm) M ,

가 (, 2 I(x,y,z) RF , RF I(x,y,z) 3
 . 3 (x_A, y_A, z_A) () RF N
 , M f_s
 N (304) (n+1) 3 (302) 2 n
 x N_y (dimension) 가 I(x,y,z) n 가 (N_x
 , k) RF 가 (virtual scan line) 가 (

$$\text{Minimize } |\theta_{xy} - \theta_k|, 1 \leq k \leq N$$

2 , xy k k I(x,y,z) (x_A, y_A, z_A) 가 RF I(x,y,z)
 I(x,y,z) 3 , k 가 RF I(x,y,z) L
 가 (3 가 "X") 가 I(x,y,z) L
 (sampling rate) (envelope) I(x,y,z) 3
 , 가 I(x,y,z) L 가
 (402) (4) (404) I(x,y,z) 3
 I(x,y,z) 3 , 가 (x₁, y₁, z₁) (x_L, y_L, z_L) L
 가 I(x,y,z) I(x,y,z)
 3 4 I(x,y,z) 3 (, k)
 , I(x,y,z) (n+1) 가 3 I(x,y,z)
 RF 3
 5 I(x,y,z) 1
 3 (500) (502), A/D(analog-to-digital) (504), RF (volume) (506),
 (508, 512), (510, 514), (522), (524), (526)
 5 (100) (110) (500) 3
 RF (502) 1 A/D (504) (102) ()
 RF RF A/D (504) RF f_s (506)
 RF RF RF RF (506) RF RF
 (506) f_s D RF N , M P RF
 3 가 D RF

$$N \cdot M \cdot \frac{2D}{c} \cdot f_s$$

가 RF (506) (508, 512) (526)

5 RF (500) (526) $I(x,y,z)$ n

(500) 2 (508, 512) , 2 $I(x,y,z)$ 3

4

$$r_{n_k} r_{n_{(k+1)}} < r_{(n+1)_k} r_{(n+1)_{k+1}}$$

$I(x,y,z)$ (, k (k+1)) RF $I(x,y,z)$ 가

RF , RF (506) (508) n $I(x,y,z)$ k

L1 (500) (k+1) RF L2 (506)

(512) (quadrature demodulation) 가

58, 512) (dynamic

ic band-pass filter) (508, 512)

(ω'_o) - (cut-off) (f' c)

(510, 512)

(weight) ω_{n_k} 가 가 (518) RF (516) 가

(k+1) RF (520) 가 $\omega_{n_{(k+1)}}$ 가 가 (518)

5 1 RF 가 가 ω_{n_k} $\omega_{n_{(k+1)}}$

5

$$\omega_{n_k} = \frac{S_{k+1}}{(S_k + S_{k+1})}$$

$$\omega_{n_{k+1}} = \frac{S_k}{(S_k + S_{k+1})}$$

5 가 RF (506)

가 (518) (510, 514) (516, 520) 가 ω_{n_k} $\omega_{n_{(k+1)}}$

가 (526) (522) (522) (510, 514)

(dynamic range) 3

3 (524) 3 (mapping)

(surface rendering), (volume rendering), (section reco

nstruction) (526)

6 , 6 2 3

6 3 (600) 2

$I(x,y,z)$ 가 k RF

$I(x,y,z)$ 가 6 3

6

$$r_{n_k}, r_{(n+1)_k} < r_{n_{(k+1)}}, r_{(n+1)_{k+1}}$$

6, (604), RF 5, (610, 614) (606), (608, 612), (622), (500) (600) 5 (500) (602), A/D (626)

RF 가 L1 (606) (608) (n+1) (610) k RF 가 L2 (606)

(612) (610) (614) n k RF (616) 가 (618) RF (614) (n+1)

ω_{n_k} 가 가 (618) RF (620) 가 $\omega_{(n+1)_k}$ 가 가 (618)

k 2 가 ω_{n_k} $\omega_{(n+1)_k}$ 7

7

$$\omega_{n_k} = \frac{f_{n+1}}{f_n + f_{n+1}}$$

$$\omega_{(n+1)_k} = \frac{f_n}{f_n + f_{n+1}}$$

가 (618) (610, 614) (616, 620) 가 ω_{n_k} $\omega_{(n+1)_k}$
 가 (626) 5 (622) (622), (624),
 , 7 2 l(x,y,z) 3
 4 RF l(x,y,z)
 3 3 (, n (n+1)) (, k (k
 +1)) 4 RF l(x,y,z) 3
 (700) 5 6 3 (500, 600) , ,
 7 3 3 (700) 4 (702, 7
 04, 706, 708), 4 (710, 712, 714, 716), 4 (718, 720, 722, 724)
 가 (726) (728) 5 6 RF 가 (702, 704,
 706, 708) () l(x,y,z) n
 k RF (702) (710) , n (k+1)
 RF (704) (712) , (n+1) k
 RF (706) (714) , (n+1) (k
 +1) RF (708) (716) ,
 (710) RF (718) 가 ω_{n_k} 가 (712)
 RF (720) 가 $\omega_{n_{k+1}}$ 가 (714)
 RF (722) 가 $\omega_{(n+1)_k}$ 가 (716) RF
 , (724) 가 $\omega_{(n+1)_{k+1}}$ 가
 (718, 720, 722, 724) 가 가 8

8

$$\begin{aligned} \omega_{n_k} &= \frac{f_{n+1}}{(f_n + f_{n+1})} \times \frac{s_{k+1}}{(s_k + s_{k+1})} \\ \omega_{n_{k+1}} &= \frac{f_{n+1}}{(f_n + f_{n+1})} \times \frac{s_k}{(s_k + s_{k+1})} \\ \omega_{(n+1)_k} &= \frac{f_n}{(f_n + f_{n+1})} \times \frac{s_{k+1}}{(s_k + s_{k+1})} \\ \omega_{(n+1)_{k+1}} &= \frac{f_n}{(f_n + f_{n+1})} \times \frac{s_k}{(s_k + s_{k+1})} \end{aligned}$$

6, 708) , 3 3 (700) 4 (702, 704, 70
 I(x,y,z) , 2 $r_{n_k}, r_{n_{(k+1)}}, r_{(n+1)_k}, r_{(n+1)_{k+1}}$
 RF I(x,y,z) 3 I(x,y,z)
 5 7 RF 3 I(x,y,z) 가
 가

가 3 가 3
 가 3 가 가 3
 가 .

(57)

1. (object) 3 3 (pixel)
 (voxel) (echo) ,
- 3 (set) , 3
2. 3
 1 (display) 3
3. 1 ,
- 3 4. 가 가
 3 3

- 4 5. , RF 3
- 5 6. , 2 RF RF (volume) 3
- 1 7. , , 3
- 7 8. , , 3
- 1 9. , 3 (volume rendering), 3 (section reconstruction) 3 (surface rendering), 3
- 1 10. , 3 3
- 4 11. 8 , 가 (weight) 가
- 3 12. 3
- 8 12. , RF 3
- 12 13. , 2 RF RF 3

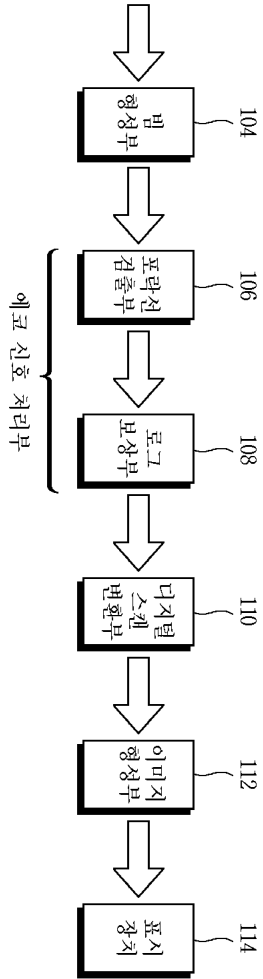
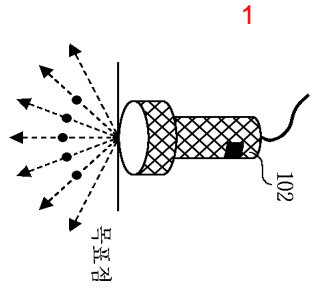

100

2

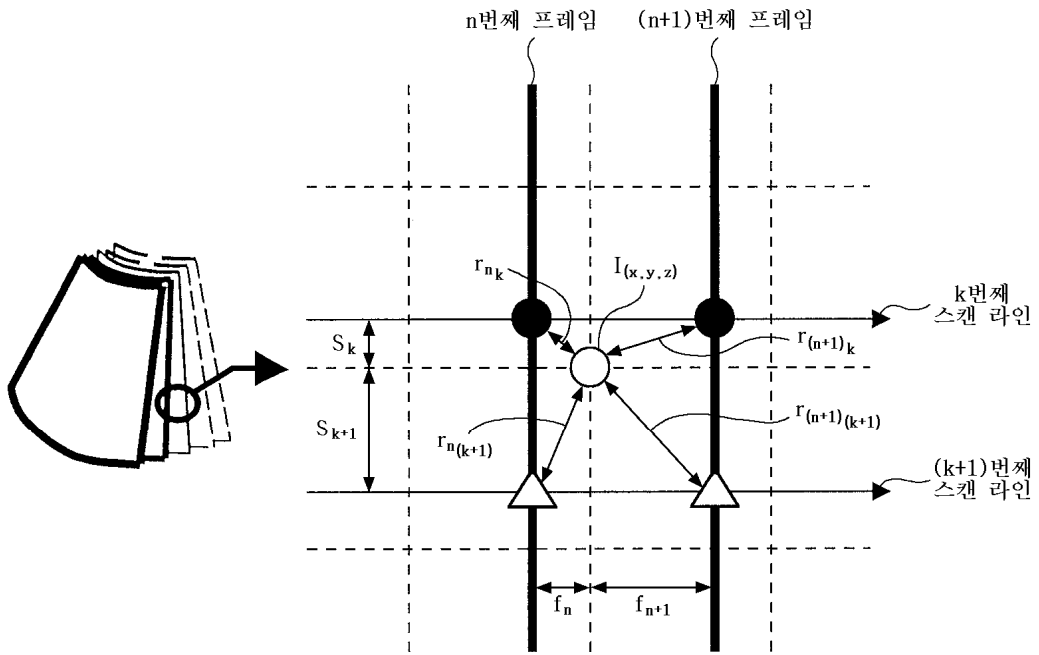

3

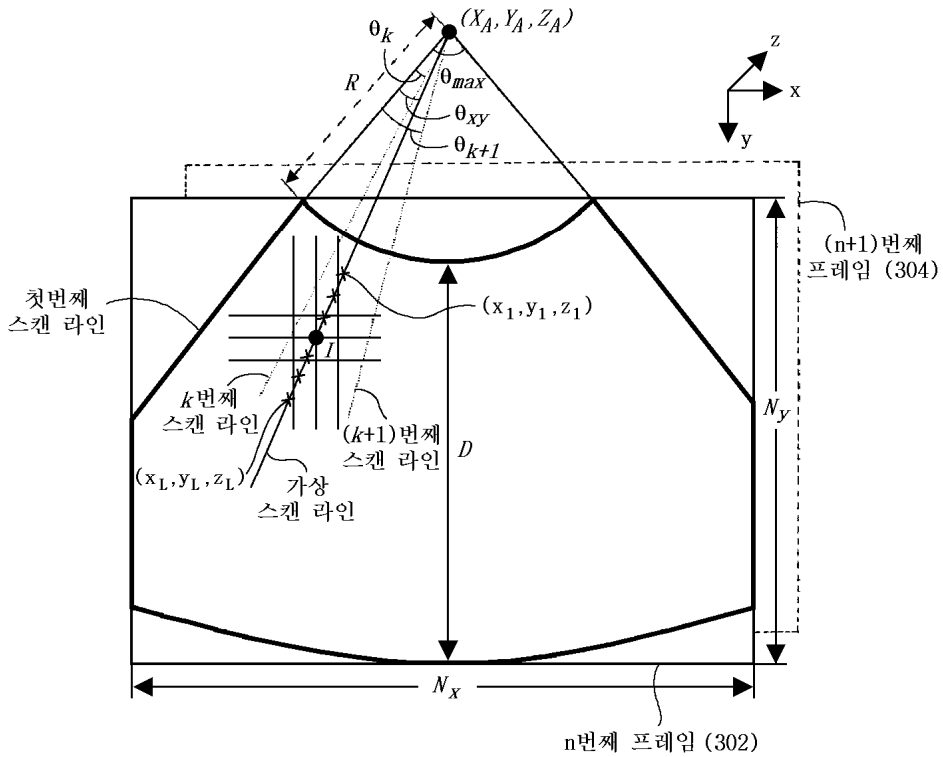

4

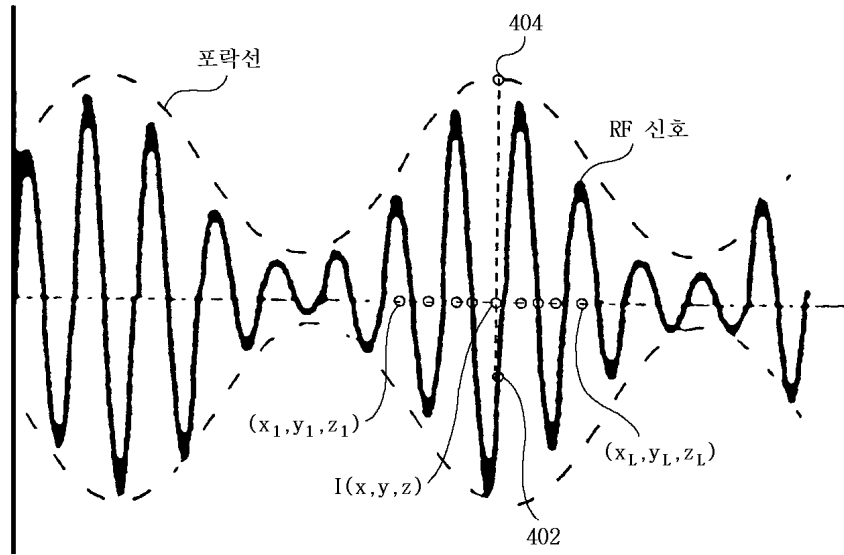

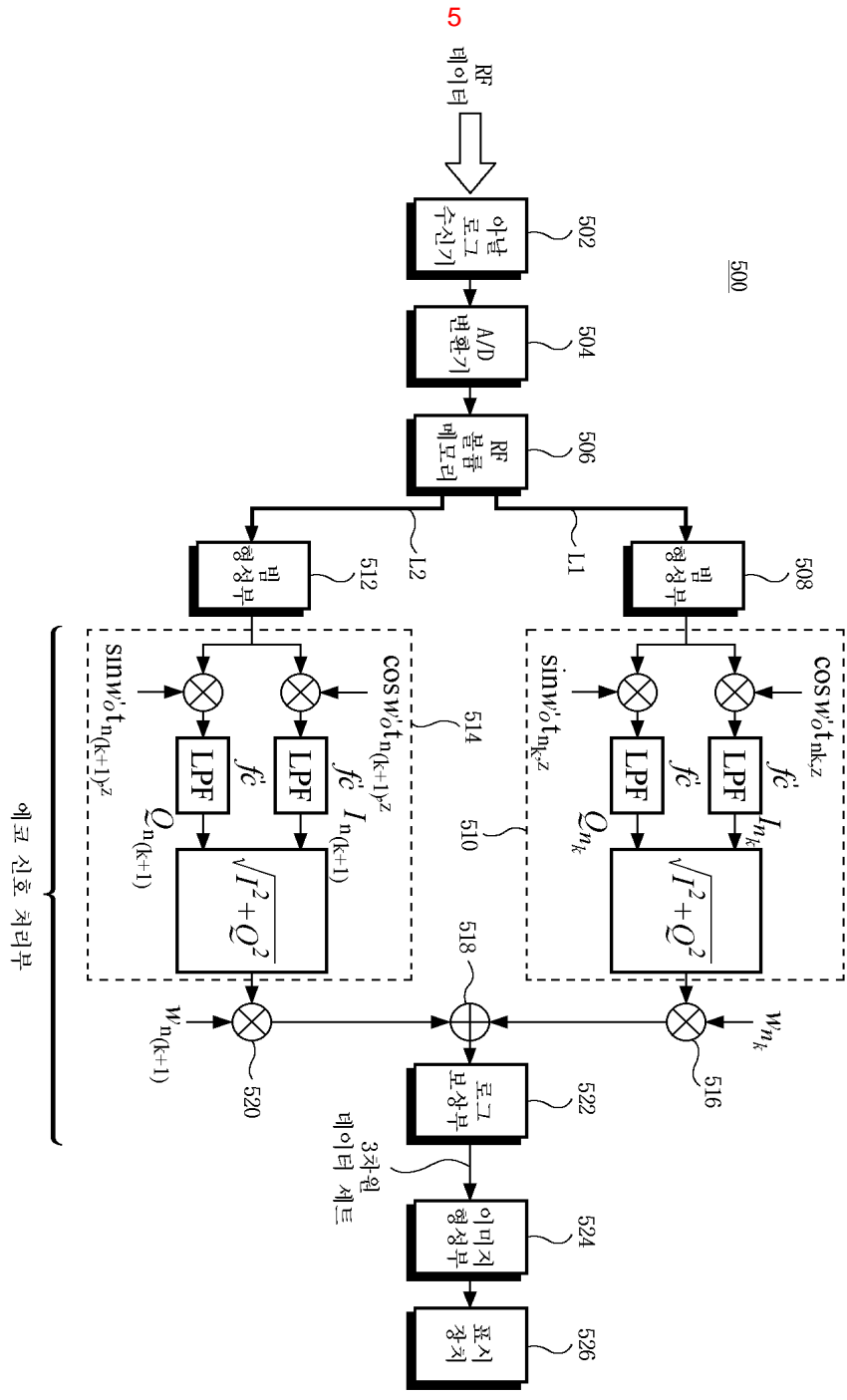

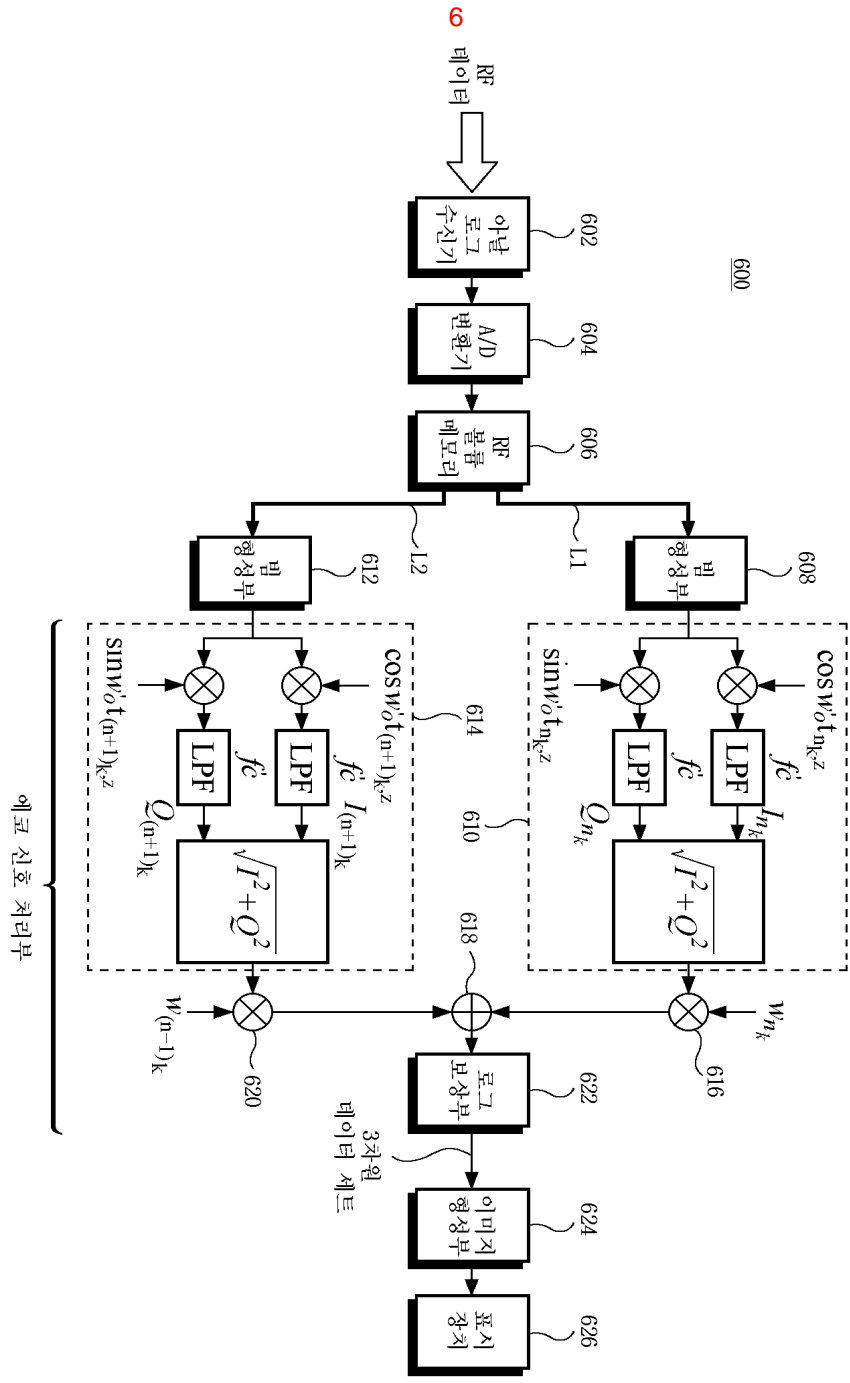

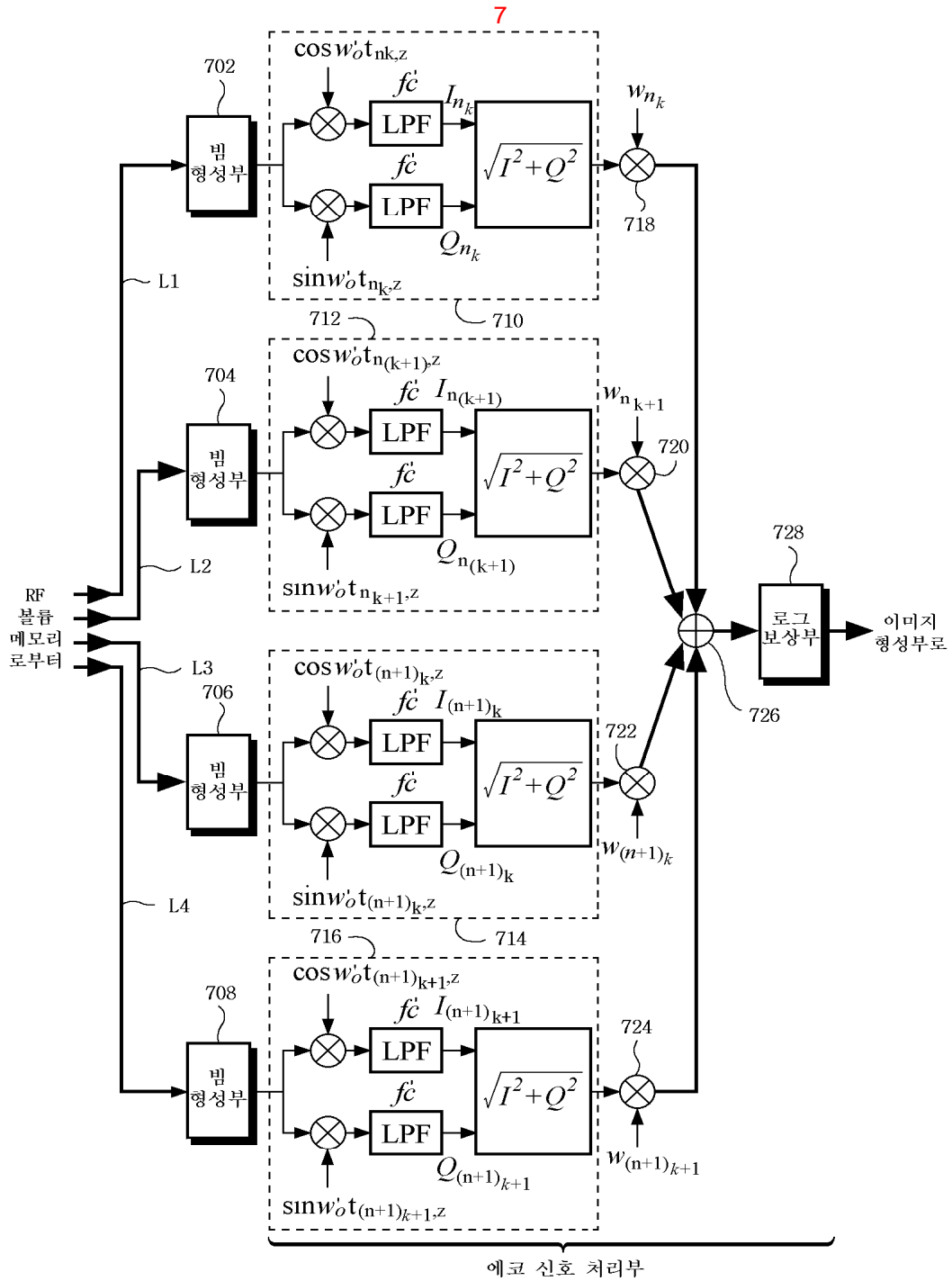

专利名称(译)	一种三维超声成像系统，其接收并聚焦在与显示装置的像素相对应的体素中		
公开(公告)号	KR100388407B1	公开(公告)日	2003-06-25
申请号	KR1020010022831	申请日	2001-04-27
[标]申请(专利权)人(译)	三星麦迪森株式会社		
申请(专利权)人(译)	三星麦迪逊有限公司		
当前申请(专利权)人(译)	三星麦迪逊有限公司		
[标]发明人	HWANG JAESUB 황재섭 SONG TAIKYONG 송태경		
发明人	황재섭 송태경		
IPC分类号	G01N29/06 G10K11/34 G01S7/52 G01S15/89 G01N29/44 G01S7/531 A61B8/00		
CPC分类号	G01S7/52044 G10K11/341 G01N29/0609 G01S7/52026 Y10S128/916 G01S15/8993		
代理人(译)	CHANG, SOO KIL CHU, 晟敏		
其他公开文献	KR1020020083321A		
外部链接	Espacenet		

摘要(译)

本发明涉及直接接收超声回波信号的三维超声图像系统，可以获得与图像显示装置的每个像素对应的诊断区域内的体素内的物体的三维图像，超声波信号在该区域内传输。对象的诊断区域。该三维超声图像系统包括用于播放分别由图像显示装置的像素形成的3D超声图像的显示装置，作为使用换能器单元，其用于具有下方发送和接收的超声信号以及RF体积存储器，存储由换能器单元接收的信号和存储在该RF体积存储器中的接收信号，其中图像形成单元基于回波信号处理器形成关于对象的3D超声图像，获得关于对应体素的3D数据集和3D数据集。显示 (显示)。 3 维超声图像系统，动态接收聚焦，RF体积记忆，体素，数字扫描转换器。

