



US 20180271486A1

(19) **United States**

(12) **Patent Application Publication**  
**YOSHIDA**

(10) **Pub. No.: US 2018/0271486 A1**

(43) **Pub. Date: Sep. 27, 2018**

(54) **ULTRASONIC DEVICE UNIT, ULTRASONIC PROBE, AND ULTRASONIC APPARATUS**

(52) **U.S. Cl.**  
CPC ..... *A61B 8/4455* (2013.01); *A61B 8/4494* (2013.01); *A61B 8/06* (2013.01); *A61B 8/461* (2013.01); *H05K 1/189* (2013.01); *A61B 8/54* (2013.01)

(71) Applicant: **Seiko Epson Corporation**, Tokyo (JP)

(72) Inventor: **Kazuki YOSHIDA**, Fujimi (JP)

(57) **ABSTRACT**

(21) Appl. No.: **15/921,992**

An ultrasonic device unit includes an ultrasonic device, and a flexible printed wiring board to be connected to the ultrasonic device, the flexible printed wiring board is provided with a device connection to which the ultrasonic device is connected, a first connector including external connection terminals to be connected to the ultrasonic device, a second connector including external connection terminals to be connected to the ultrasonic device, a first inflective part adapted to link the device connection and the first connector to each other, and a second inflective part adapted to link the device connection and the second connector to each other, and a distance between the device connection and the first inflective part and a distance between the device connection and the first connector in the second inflective part are different from each other.

(22) Filed: **Mar. 15, 2018**

(30) **Foreign Application Priority Data**

Mar. 22, 2017 (JP) ..... 2017-055390

**Publication Classification**

(51) **Int. Cl.**  
*A61B 8/00* (2006.01)  
*H05K 1/18* (2006.01)

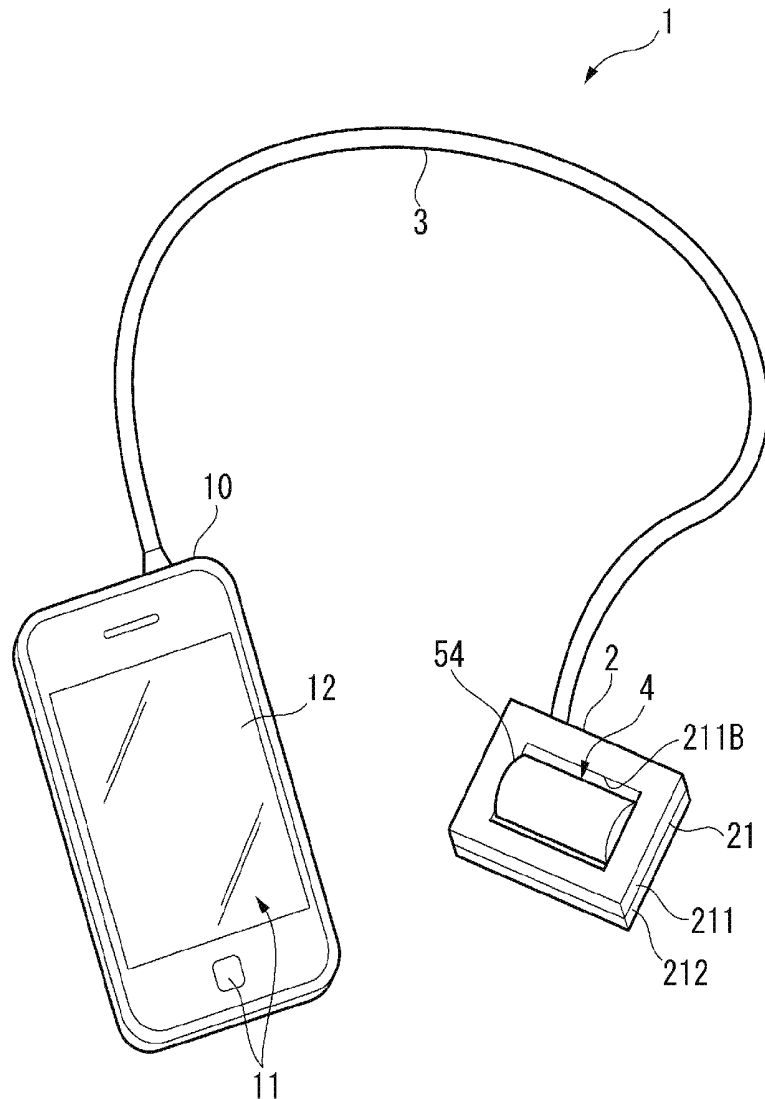

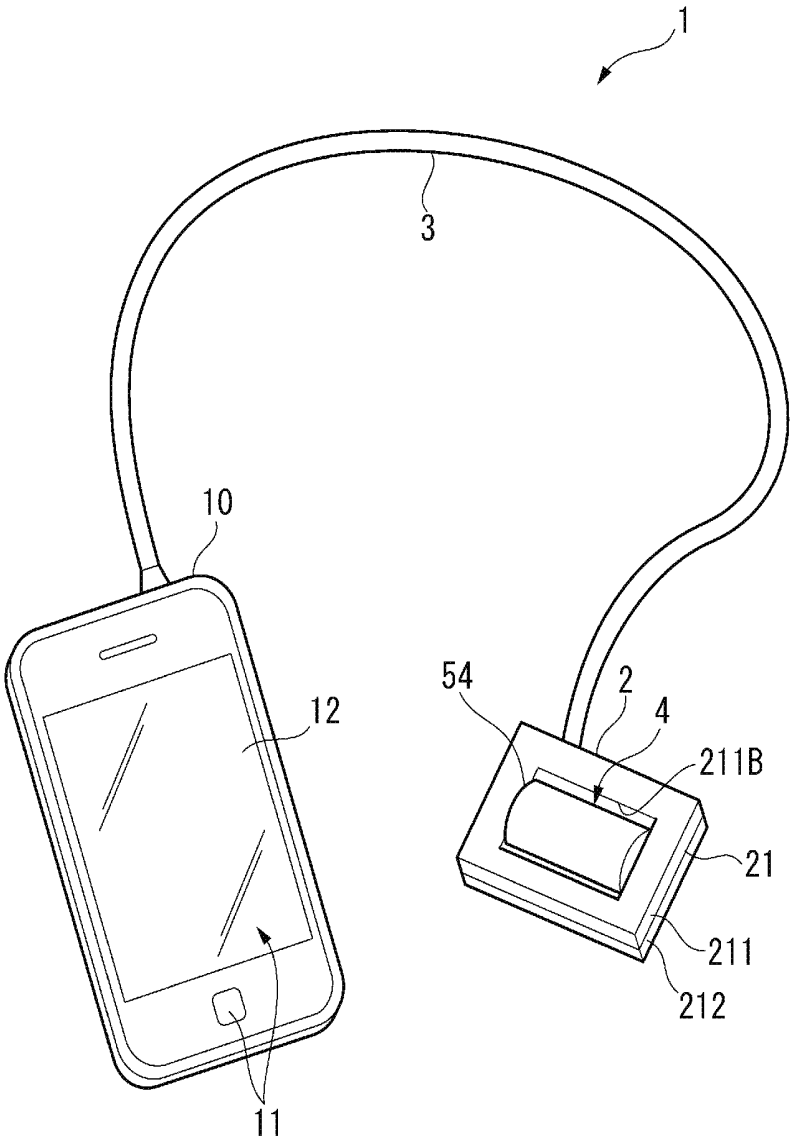

FIG. 1

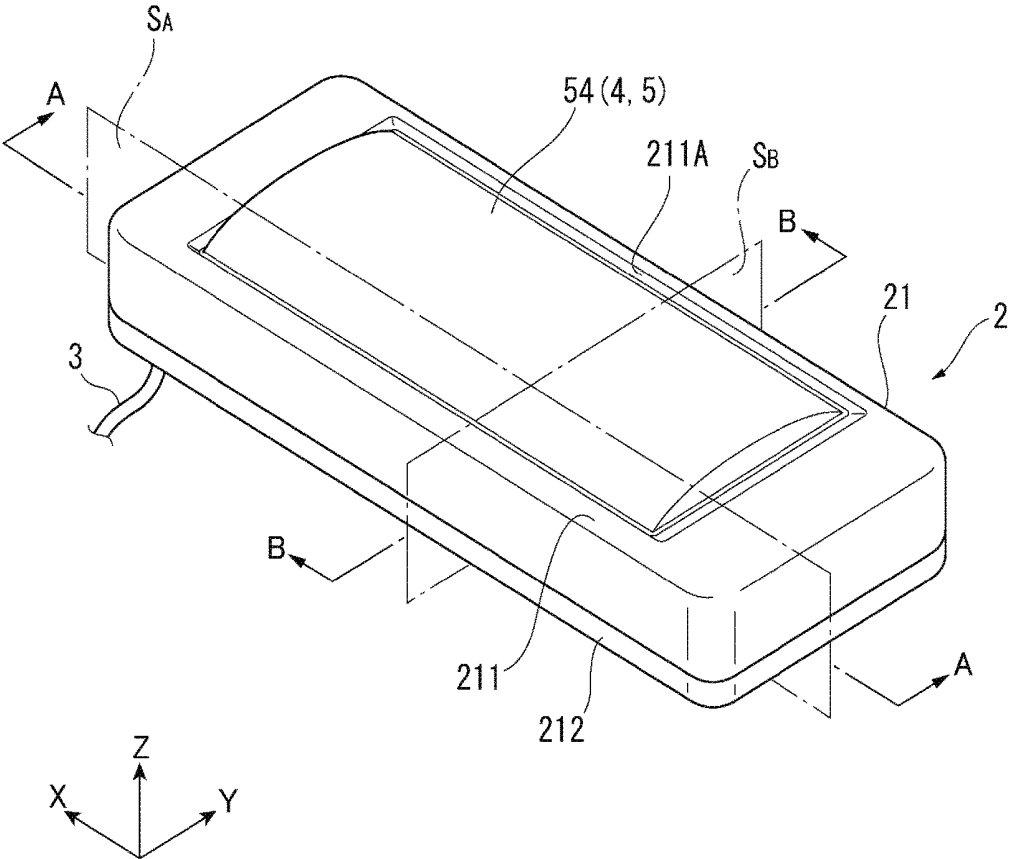

FIG. 2



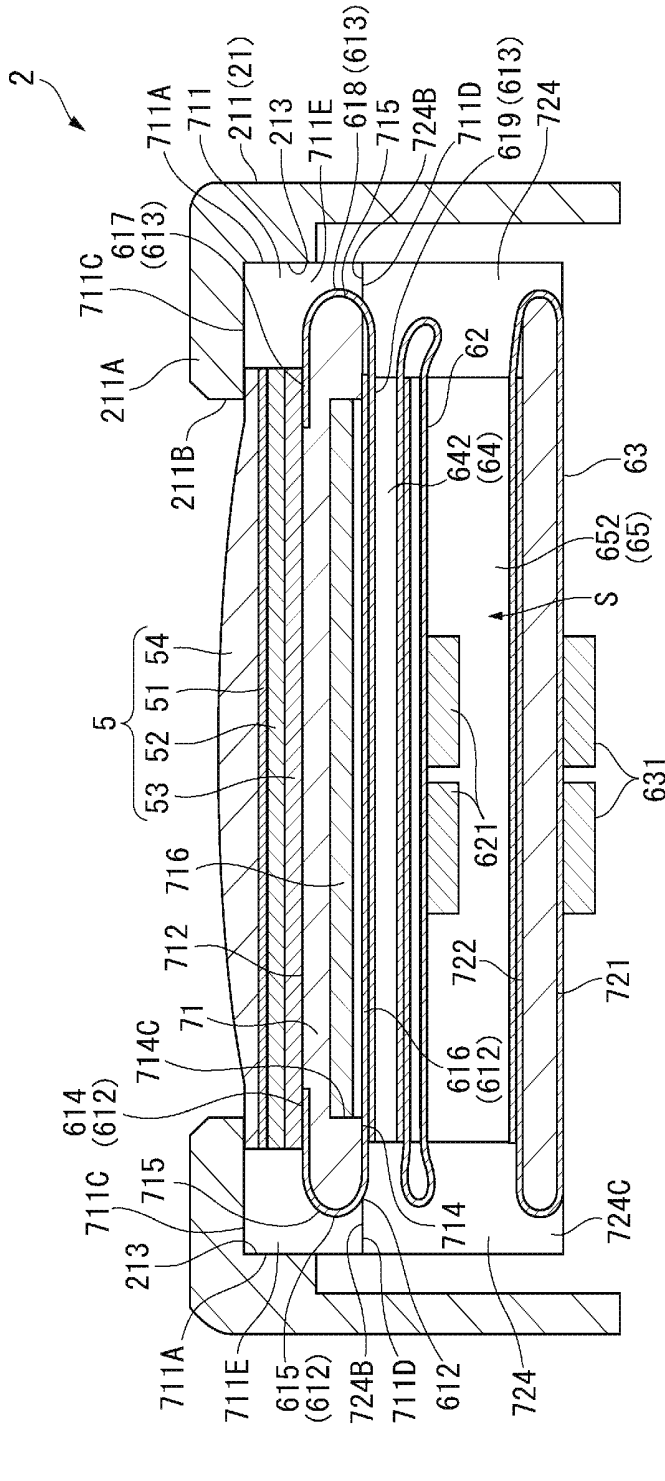

FIG. 4



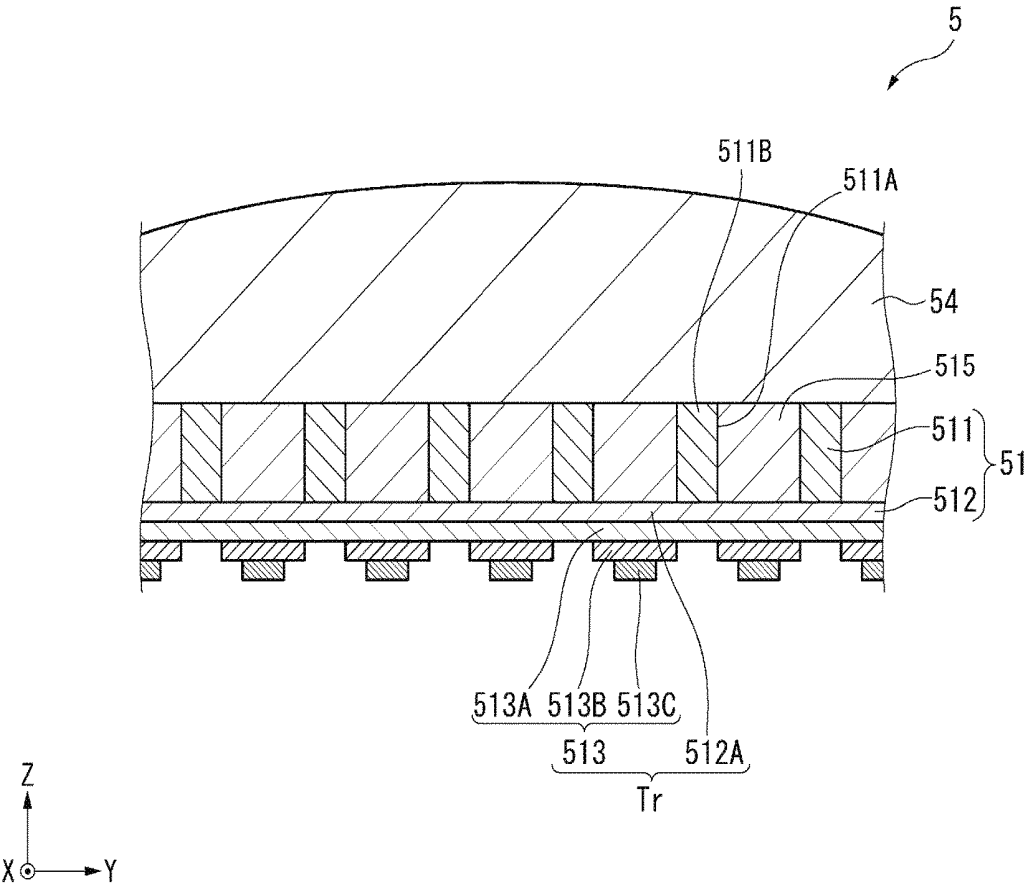

FIG. 6

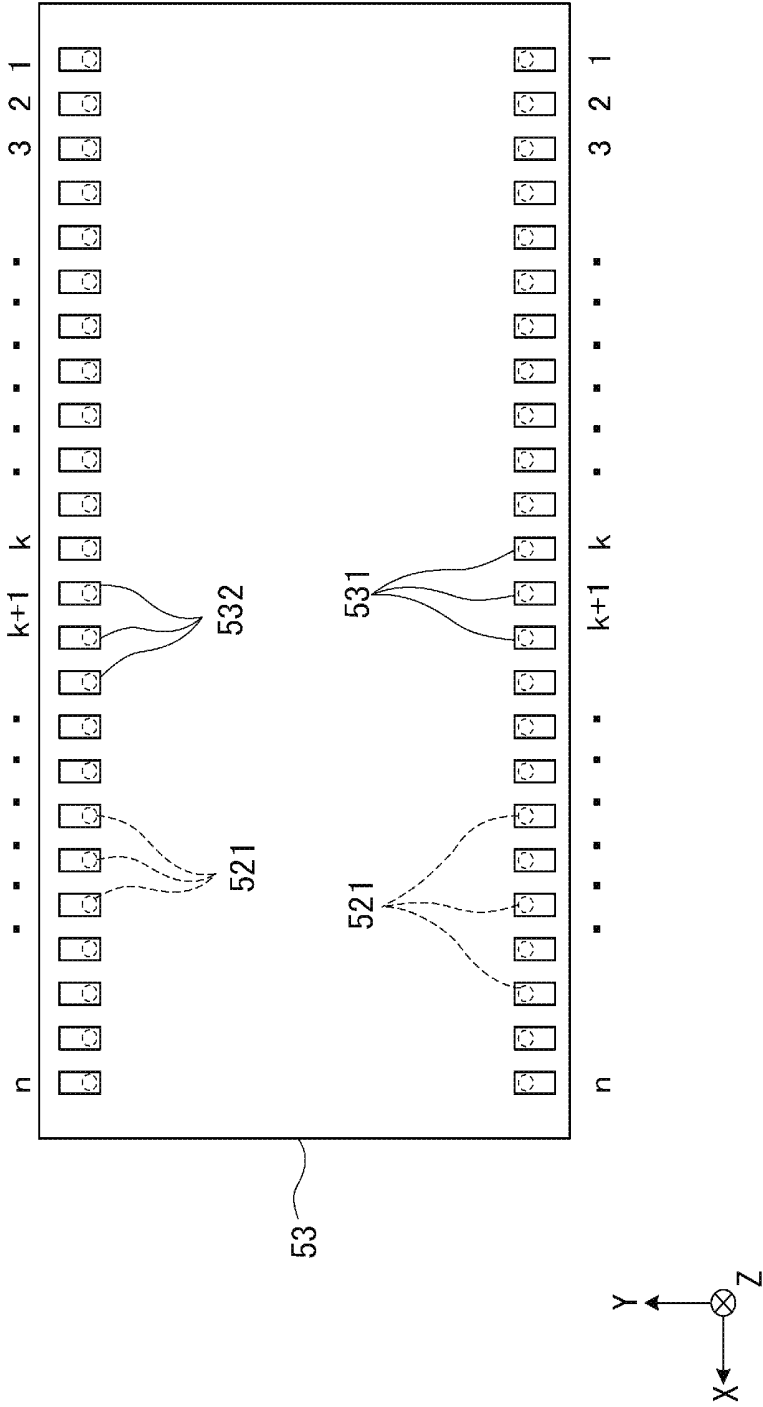

FIG. 7

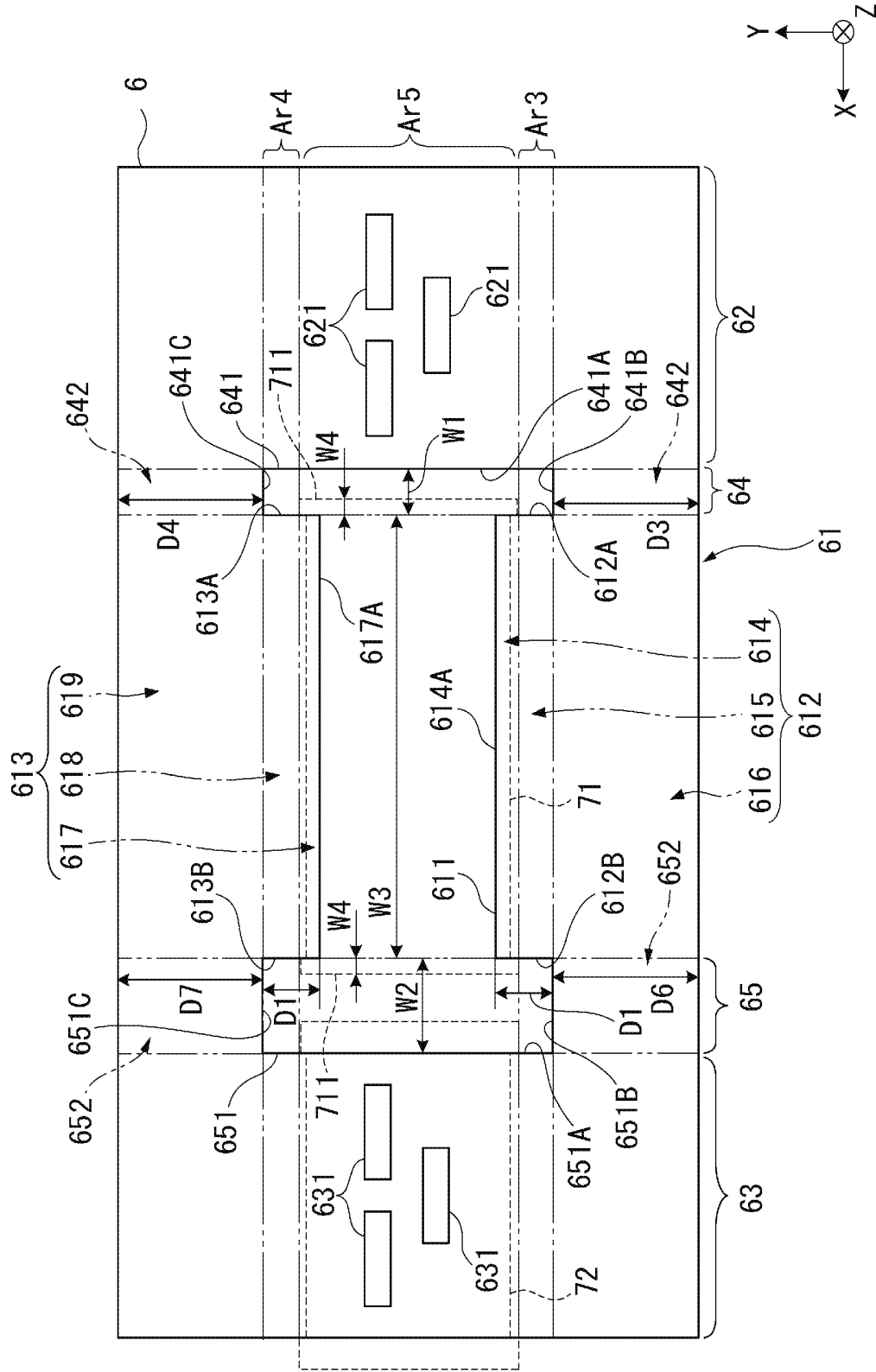

FIG. 8

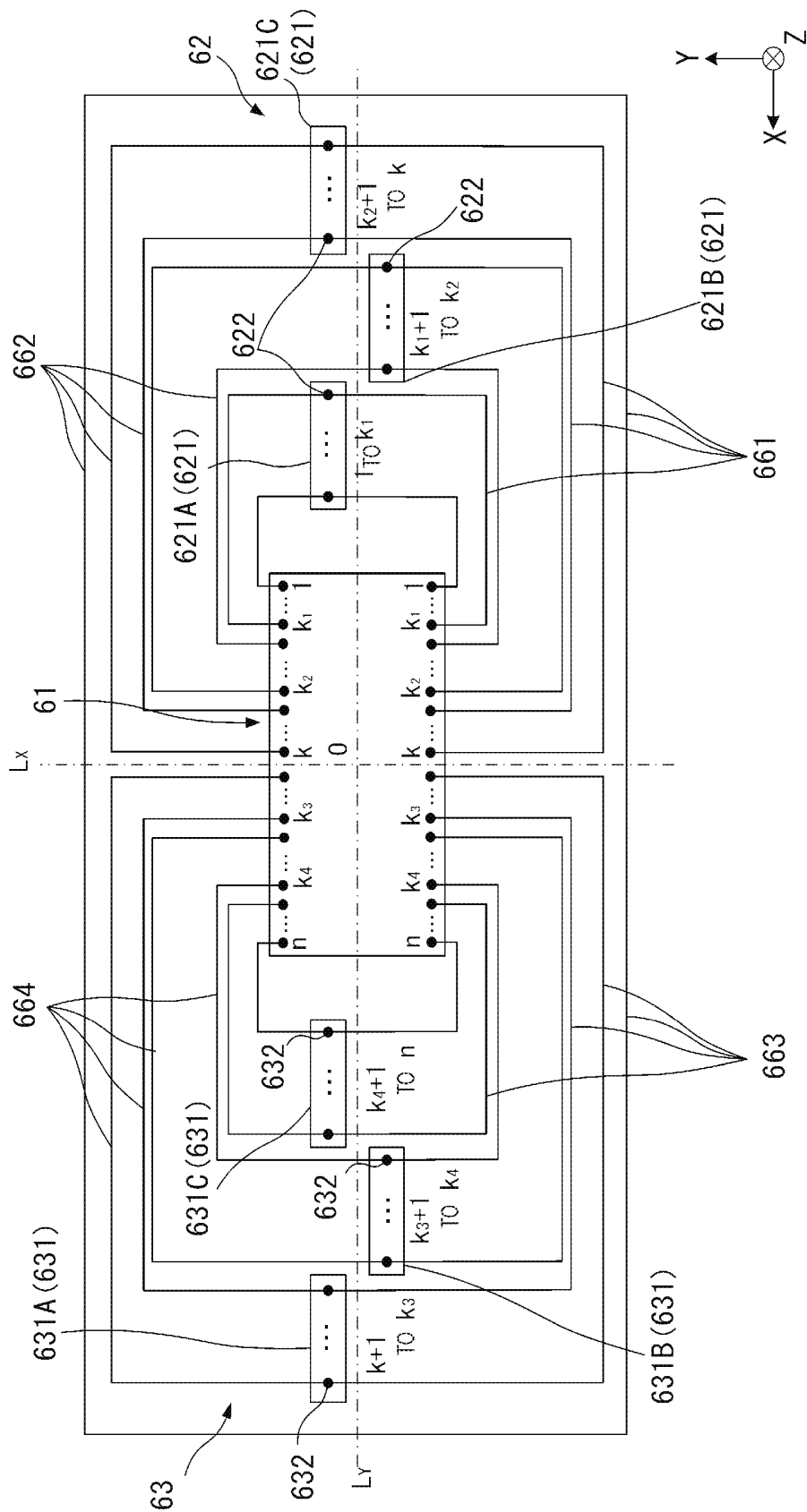

FIG. 9

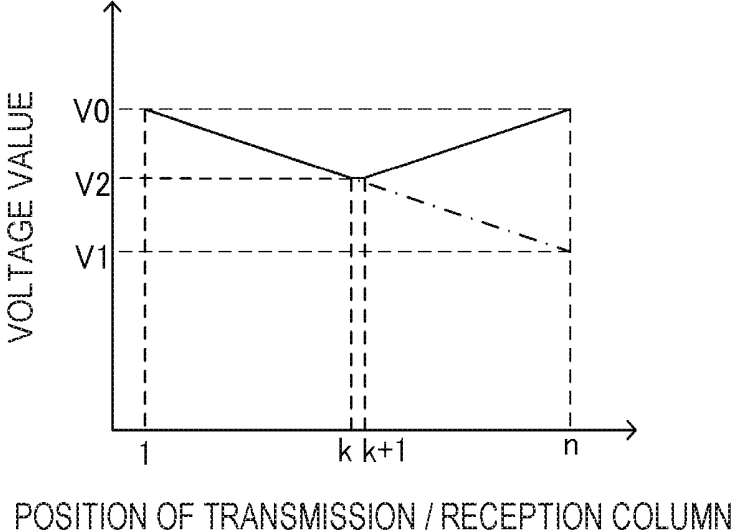

FIG. 10

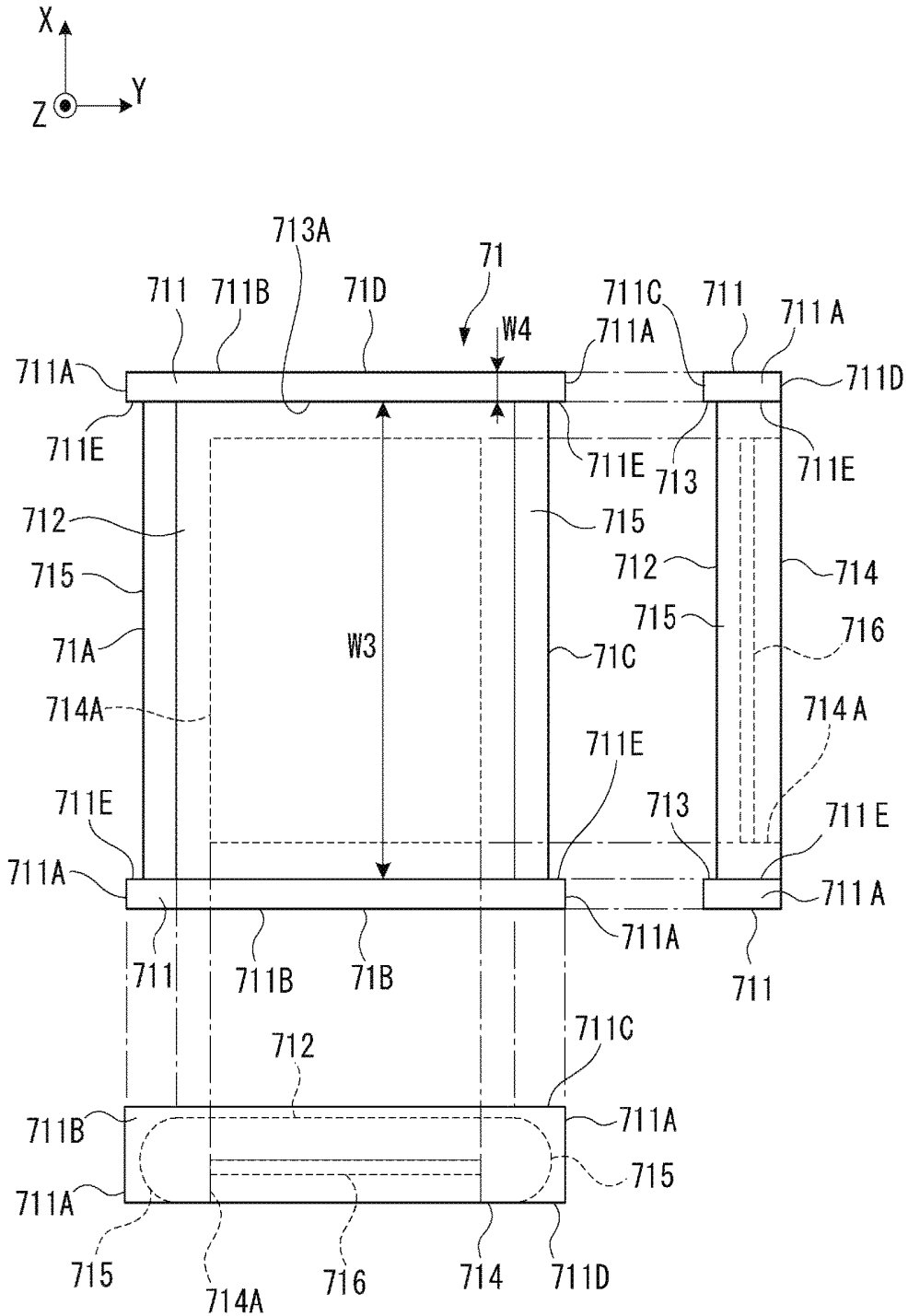

FIG. 11

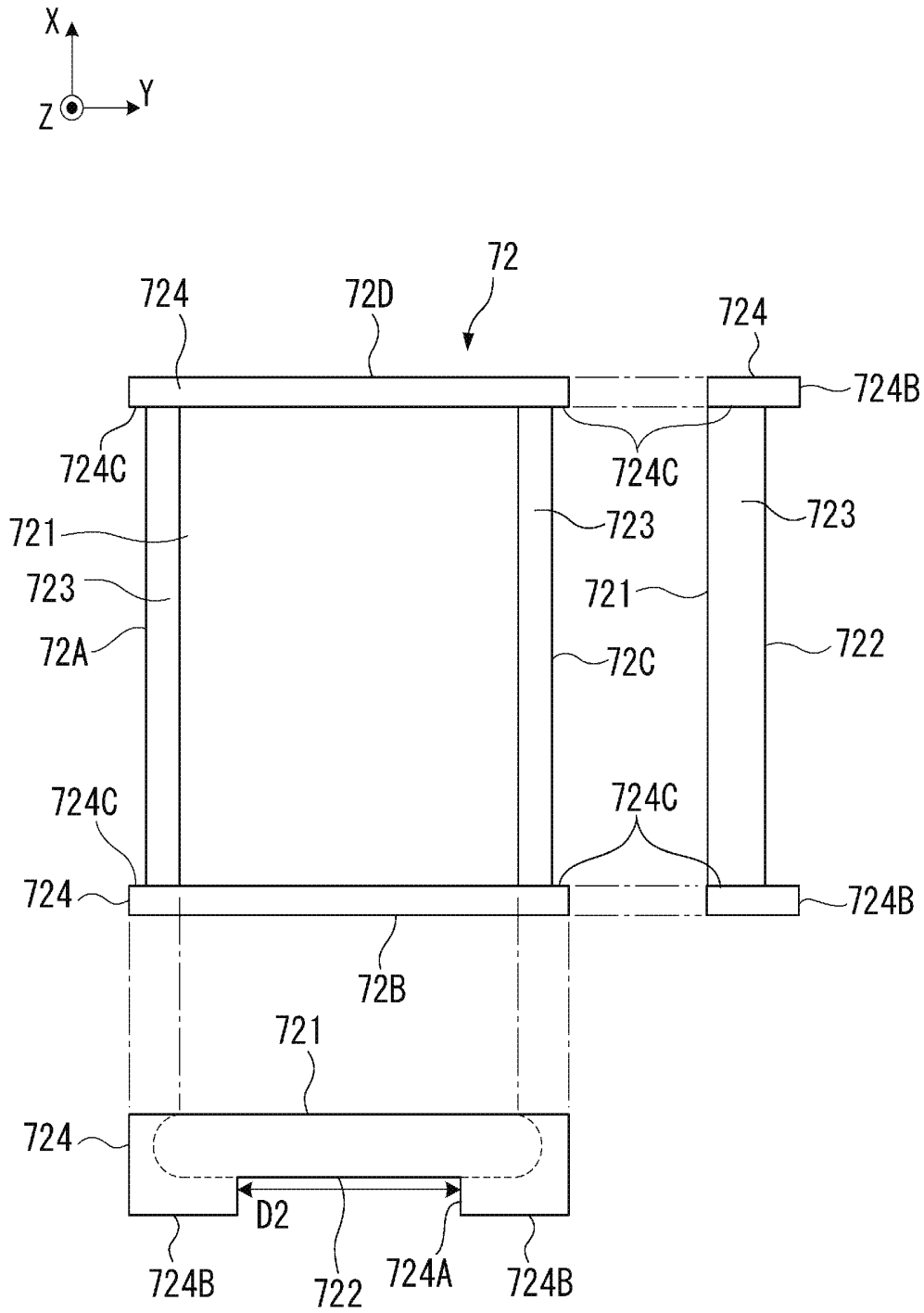

FIG. 12

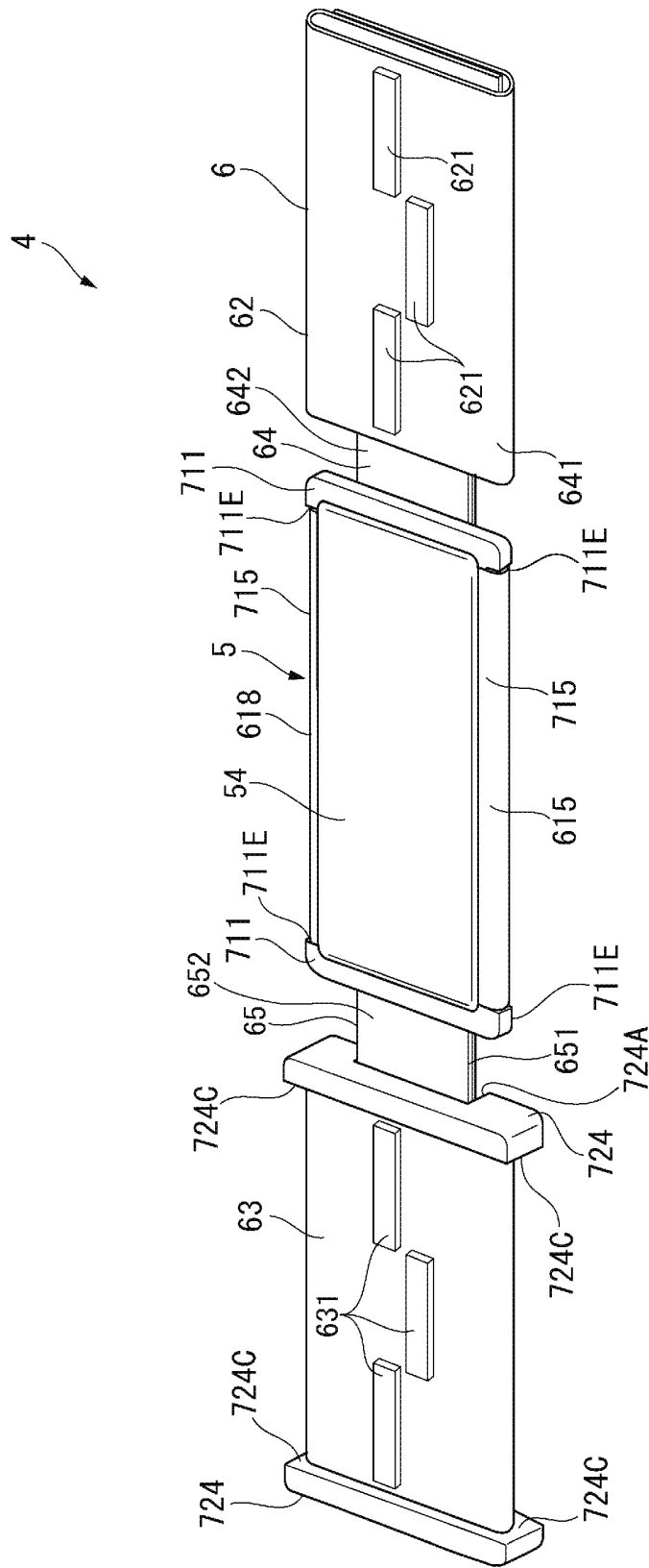

FIG.13

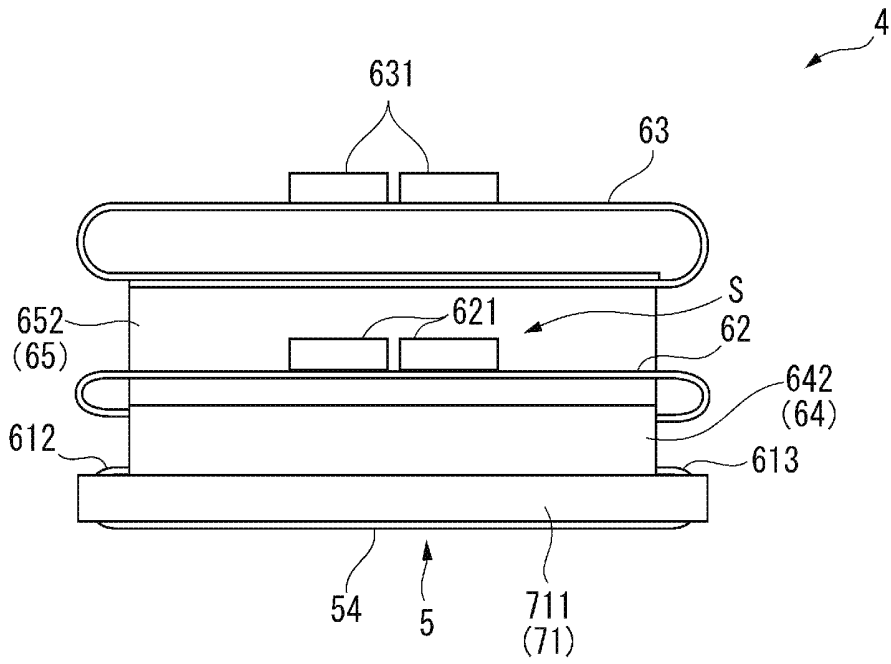

FIG. 14

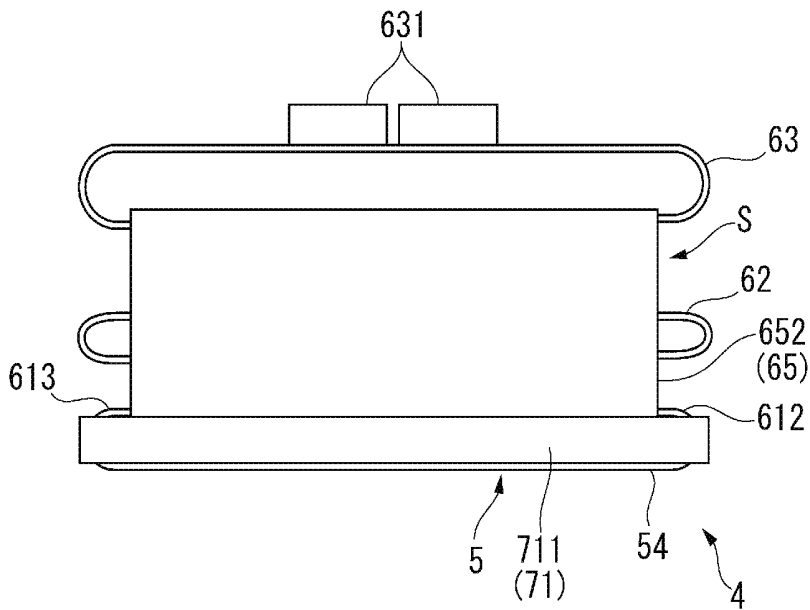

FIG. 15

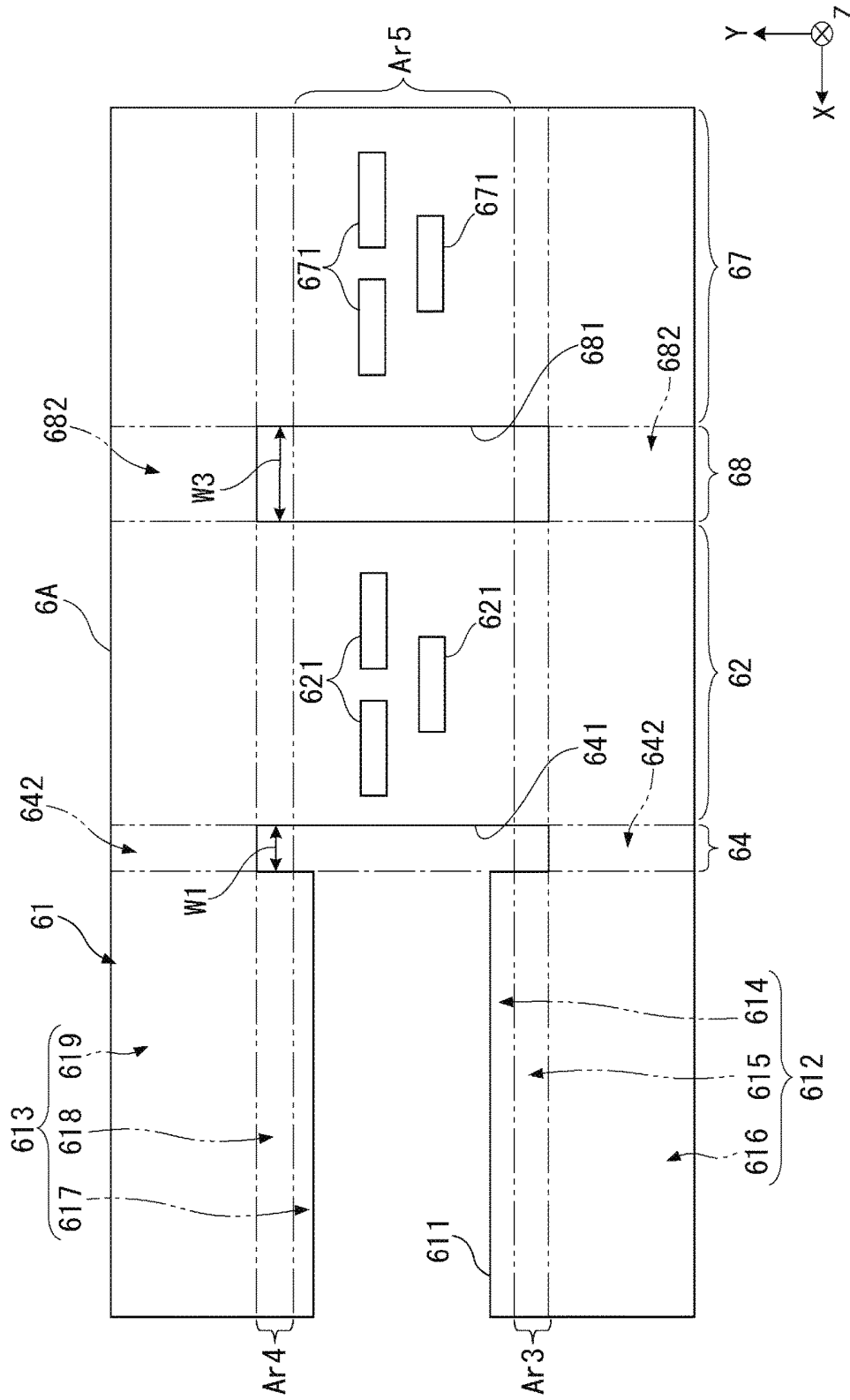

FIG. 16

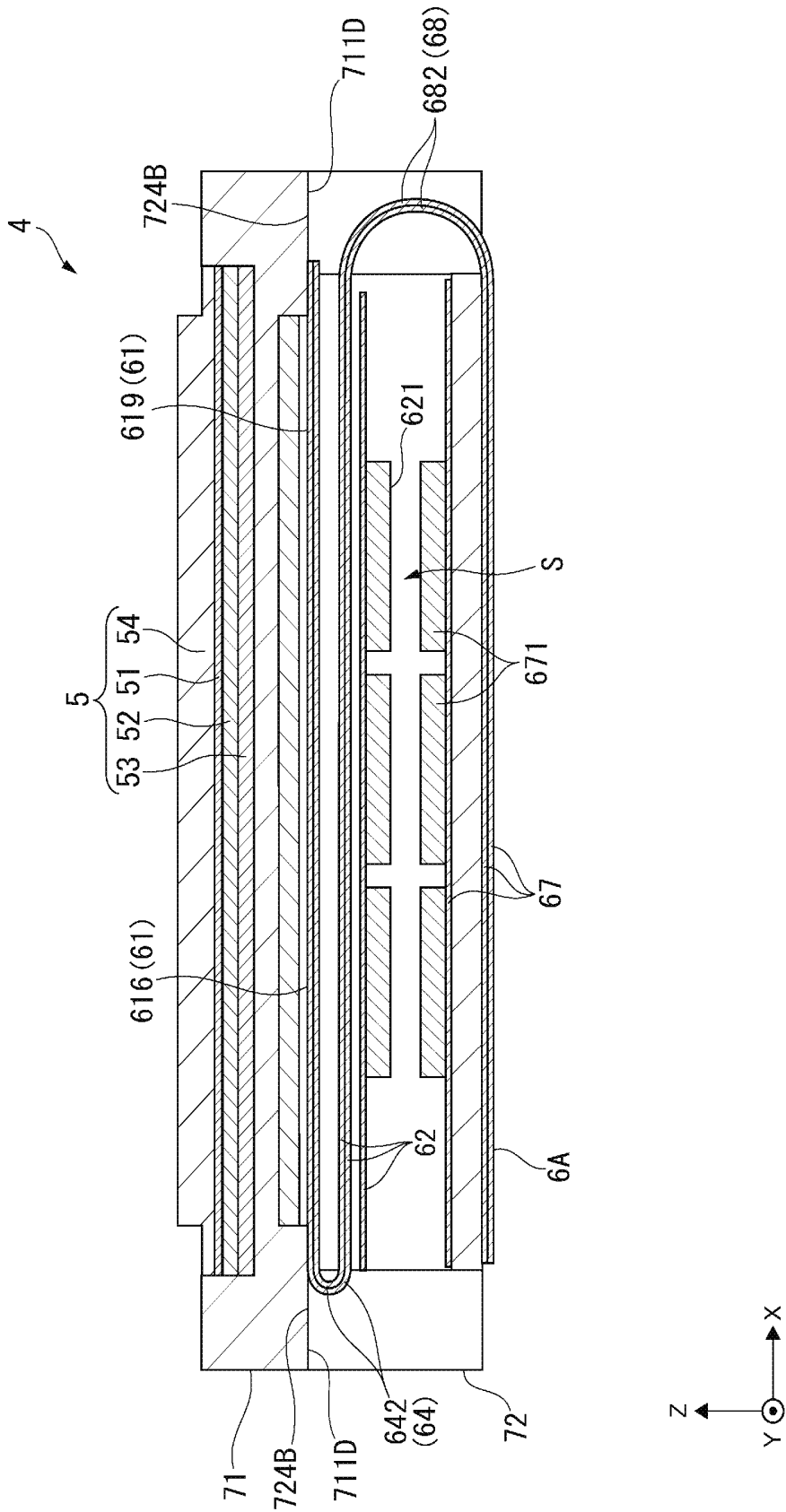

FIG. 17





## ULTRASONIC DEVICE UNIT, ULTRASONIC PROBE, AND ULTRASONIC APPARATUS

### BACKGROUND

#### 1. Technical Field

[0001] The present invention relates to an ultrasonic device unit, an ultrasonic probe, and an ultrasonic apparatus.

#### 2. Related Art

[0002] In the past, there has been known an ultrasonic device unit having an ultrasonic element array in which ultrasonic elements for performing transmission and reception of ultrasonic waves are arranged (see, e.g., JP-A-2016-92592 (Document 1)).

[0003] The ultrasonic device unit of Document 1 is provided with the ultrasonic device having terminals corresponding respectively to the ultrasonic elements, and the ultrasonic device is connected to a device terminal via a flexible printed wiring board (a flexible board).

[0004] The flexible board is provided with a first flat-plate part disposed on one end side with respect to the center line, and the ultrasonic device is fixed to the first flat-plate part. Further, the flexible board is provided with a second flat-plate part disposed on the other end side with respect to the center line, and connectors to which the terminals of the ultrasonic device are connected are disposed in the second flat-plate part.

[0005] Incidentally, in such an ultrasonic device as described in Document 1 described above, as the number of the ultrasonic elements included in the ultrasonic device increases, the number of the terminals and the number of the connectors also increase accordingly. In this case, it becomes difficult to dispose all of the connectors in the second flat-plate part, and the interconnections to the connectors also become complicated. In contrast, by separately providing a third flat-plate part for disposing the connectors to the first flat-plate part, and disposing the connectors in both of the second flat-plate part and the third flat-plate part, such a problem as described above can be solved.

[0006] On the other hand, in the ultrasonic device unit, since it is necessary to dispose the ultrasonic device and the flexible board in a limited space, the second flat-plate part is folded back (curved) to overlap the first flat-plate part as described in Document 1. Here, in the case in which the third flat-plate part is disposed in addition to the second flat-plate part as described above, if the second flat-plate part and the third flat-plate part are curved so as to overlap the first flat-plate part, the second flat-plate part and the third flat-plate part interfere with each other to make the wiring connection to the connectors difficult.

[0007] Further, it is also possible to bend the flexible board so that the curvature between the first flat-plate part and the second flat-plate part and the curvature between the first flat-plate part and the third flat-plate part are different from each other to thereby prevent the second flat-plate part and the third flat-plate part from interfering with each other. However, in such a case, in the part with the smaller curvature, the flexible board significantly projects outward from the first flat-plate part, and it becomes difficult to dispose the ultrasonic device and the flexible board within the limited space.

[0008] For the above reason, there is desired an ultrasonic device unit which is easy in wiring connection, and can be miniaturized.

### SUMMARY

[0009] An advantage of some aspects of the invention is to provide an ultrasonic device unit, an ultrasonic probe, and an ultrasonic apparatus which are easy in wiring connection, and can be miniaturized.

[0010] An ultrasonic device unit according to an application example of the invention includes an ultrasonic device, and a flexible printed wiring board to be connected to the ultrasonic device, the flexible printed wiring board is provided with a device connection section to which the ultrasonic device is connected, a first connector section including a plurality of external connection terminals to be connected to the ultrasonic device, a second connector section including a plurality of external connection terminals to be connected to the ultrasonic device, a first inflective part disposed between the device connection section and the first connector section, and adapted to link the device connection section and the first connector section to each other, and a second inflective part disposed between the device connection section and the second connector section, and adapted to link the device connection section and the second connector section to each other, and a distance between the device connection section and the first connector section in the first inflective part and a distance between the device connection section and the second connector section in the second inflective part are different from each other.

[0011] In this application example, in the flexible printed wiring board, to the device connection section to which the ultrasonic device is connected, the first connector section is connected via the first inflective part, and the second connector section is connected via the second inflective part. Further, in this application example, the distance from the device connection section to the first connector section of the first inflective part, and the distance from the device connection section to the second connector section of the second inflective part are different from each other.

[0012] In such a configuration, a position (a position in the overlapping direction) of the first connector section in the case of bending the first inflective part so as to overlap the first connector section with the device connection section, and a position (a position in the overlapping direction) of the second connector section in the case of bending the second inflective part so as to overlap the second connector section with the device connection section are different from each other. Therefore, the first connector section and the second connector section do not interfere with each other, and thus, the connection of the interconnections to the first connector section and the second connector section becomes easy. Further, out of the first connector section and the second connector section, one shorter in distance from the device connection section is disposed on a side closer to the device connection section, and the other is disposed on a side farther from the device connection section, and thus, it is possible to prevent the first inflective part and the second inflective part from projecting outside the outer edge of the device connection section in a planar view viewed from the overlapping direction of the flexible printed wiring board to thereby achieve the miniaturization.

[0013] In the ultrasonic device unit according to the application example, it is preferable that the first inflective part is

provided with a first slit, the second inflective part is provided with a second slit, and a width dimension in a direction from the device connection section toward the first connector section of the first slit, and a width dimension in a direction from the device connection section toward the second connector section of the second slit are different from each other.

[0014] In the application example with this configuration, the first inflective part is provided with the first slit, and the second inflective part is provided with the second slit. In the case in which the first slit and the second slit as described above are provided, it becomes easy to curve the first inflective part and the second inflective part along the first slit and the second slit. Further, since the first slit and the second slit are different in width dimension from each other, there is obtained a configuration in which the dimension of a part easy to bend is different between the first slit and the second slit. Thus, similarly to the application example described above, it becomes possible to easily dispose the first connector section and the second connector section at positions where the first connector section and the second connector section do not interfere with each other.

[0015] In the ultrasonic device unit according to the application example, it is preferable that a width dimension in a direction crossing the direction from the device connection section toward the first connector section of the first slit is larger than a width dimension in the direction crossing the direction from the device connection section toward the first connector section of the ultrasonic device, and a width dimension in a direction crossing the direction from the device connection section toward the second connector section of the second slit is larger than a width dimension in the direction crossing the direction from the device connection section toward the second connector section of the ultrasonic device.

[0016] In the application example with this configuration, the width dimension (the dimension in the longitudinal direction of the first slit) in the direction (a first crossing direction) crossing the direction (a first connection direction) from the device connection section toward the first connector section of the first slit is larger than the width dimension in the first crossing direction of the ultrasonic device.

[0017] In such a configuration, the flexible printed wiring board is bent in the both end edges parallel to the first connection direction of the ultrasonic device, and then, the first inflective part is curved to be bent at the position where the first slit is disposed. Thus, in the direction from the device connection section toward the first connector section, the flexible printed wiring board thus bent overlaps in three layers in the first connector section and the device connection section on the one hand, but overlaps only in two layers in the first inflective part on the other hand. Therefore, it becomes easy to curve the first inflective part.

[0018] The same applies in the second inflective part, and the width dimension (the dimension in the longitudinal direction of the second slit) in the direction (a second crossing direction) crossing the direction (a second connection direction) from the device connection section toward the second connector section of the second slit is larger than the width dimension in the second crossing direction of the ultrasonic device. Therefore, the flexible printed wiring board is bent in the both end edges parallel to the second connection direction of the ultrasonic device, and then, the second inflective part is curved to be bent at the position

where the second slit is disposed, and thus, the second inflective part is provided with a shape easy to bend.

[0019] Therefore, it becomes possible to easily change the shape of the flexible printed wiring board so that the first connector section and the second connector section overlap the device connection section.

[0020] In the ultrasonic device unit according to the application example, it is preferable that a width dimension in a direction from the device connection section toward the first connector section of the first connector section is smaller than a width dimension in the direction from the device connection section toward the first connector section of the device connection section, and a width dimension in the direction from the device connection section toward the second connector section of the second connector section is smaller than a width dimension in the direction from the device connection section toward the second connector section of the device connection section.

[0021] In the application example with this configuration, the width dimension in the first connection direction of the first connector section is smaller than the width dimension in the first connection direction of the device connection section, and the width dimension in the second connection direction of the second connector section is smaller than the width dimension in the first connection direction of the device connection section. Therefore, in the case of bending the first inflective part and the second inflective part so as to overlap the first connector section and the second connector section with the device connection section, it is possible to prevent the first connector section and the second connector section from projecting outside the outer edge of the device connection section in the planar view viewed from the overlapping direction to thereby achieve the miniaturization.

[0022] In the ultrasonic device unit according to the application example, it is preferable that the device connection section, the first connector section, and the second connector section are arranged in a first direction, and the device connection section is located between the first connector section and the second connector section.

[0023] In the application example with this configuration, the first connector section and the second connector section are disposed along the first direction across the device connection section from each other. In such a configuration, it is possible to provide a symmetrical structure to the interconnections extending from the device connection section toward the first connector section, and the interconnections extending from the device connection section toward the second connector section in the flexible printed wiring board. Therefore, it is possible to prevent a disadvantage that the output of the ultrasonic wave output from the ultrasonic device becomes uneven due to the voltage drop caused by the interconnections.

[0024] An ultrasonic device unit according to an application example of the invention includes an ultrasonic device, and a flexible printed wiring board to be connected to the ultrasonic device, the flexible printed wiring board is provided with a device connection section to which the ultrasonic device is connected, a first connector section including a plurality of external connection terminals to be connected to the ultrasonic device, a second connector section including a plurality of external connection terminals to be connected to the ultrasonic device, a first inflective part disposed between the device connection section and the first connector section, and adapted to link the device connection section

and the first connector section to each other, and a third inflective part disposed between the first connector section and the second connector section, and adapted to link the first connector section and the second connector section to each other, and a distance between the device connection section and the first connector section in the first inflective part and a distance between the first connector section and the second connector section in the third inflective part are different from each other.

**[0025]** In this application example, the first connector section is linked to the device connection section via the first inflective part, the second connector section is linked to the first connector section via the third inflective part, and the distance from the device connection section to the first connector section of the first inflective part and the distance from the first connector section to the second connector section of the third inflective part are different from each other.

**[0026]** In such a configuration, when overlapping the first connector section and the second connector section with the device connection section, it is possible to curve the first inflective part to overlap the first connector section and the second connector section with the device connection section, and then curve the third inflective part so that the second connector section intervenes between the first connector section and the device connection section. On this occasion, the distance from the device connection section to the first connector section is made longer than the distance from the first connector section to the second connector section. Thus, the interference between the first connector section and the second connector section can be prevented, and at the same time, the first inflective part and the third inflective part are prevented from projecting from the outer edge of the device connection section in the planar view, and thus the miniaturization can be achieved.

**[0027]** Further, when overlapping the first connector section and the second connector section with the device connection section, it is also possible to curve the first inflective part to overlap the first connector section and the second connector section with the device connection section, and then curve the third inflective part so that the second connector section is located on the opposite side to the device connection section of the first connector section. On this occasion, the distance from the device connection section to the first connector section is made shorter than the distance from the first connector section to the second connector section. Thus, the interference between the first connector section and the second connector section can be prevented, and at the same time, the first inflective part and the third inflective part are prevented from projecting from the outer edge of the device connection section in the planar view, and thus the miniaturization can be achieved.

**[0028]** An ultrasonic probe according to an application example of the invention includes the ultrasonic device unit according to any one of the application examples described above, and a housing adapted to store the ultrasonic device unit.

**[0029]** In the ultrasonic probe according to this application example, such an ultrasonic device unit as described above is housed in the housing, and by making the ultrasonic probe have contact with the test object, the ultrasonic measurement on the test object can be performed. Further, as described above, the ultrasonic device unit can be miniaturized while preventing the interference between the connector sections.

Therefore, in the ultrasonic probe, the interconnections can easily be connected to the ultrasonic device unit, and at the same time, the miniaturization of the ultrasonic probe can also be achieved.

**[0030]** An ultrasonic apparatus according to an application example of the invention includes the ultrasonic device unit according to any one of the application examples described above, and a control section adapted to control the ultrasonic device unit.

**[0031]** In this application example, by controlling such an ultrasonic device unit as described above with the control section, it is possible to perform a variety of types of ultrasonic processing (e.g., ultrasonic measurement on the test object, and ultrasonic therapy on the test object) in accordance with the measurement result of the ultrasonic measurement. Further, since the ultrasonic device unit can be miniaturized as describe above, the miniaturization of the ultrasonic apparatus can also be achieved.

#### BRIEF DESCRIPTION OF THE DRAWINGS

**[0032]** The invention will be described with reference to the accompanying drawings, wherein like numbers refer to like elements.

**[0033]** FIG. 1 is a perspective view showing a schematic configuration of an ultrasonic measurement apparatus according to a first embodiment of the invention.

**[0034]** FIG. 2 is a perspective view showing an appearance of the ultrasonic probe according to the first embodiment.

**[0035]** FIG. 3 is a cross-sectional view of the ultrasonic probe cut along the line A-A shown in FIG. 2.

**[0036]** FIG. 4 is a cross-sectional view of the ultrasonic probe cut along the line B-B shown in FIG. 2.

**[0037]** FIG. 5 is a plan view showing a schematic configuration of an ultrasonic substrate of the first embodiment.

**[0038]** FIG. 6 is a cross-sectional view of the ultrasonic substrate cut along the line C-C shown in FIG. 5.

**[0039]** FIG. 7 is a plan view showing a schematic configuration of a wiring board of the first embodiment.

**[0040]** FIG. 8 is a plan view showing a schematic configuration of a surface of a flexible board of the first embodiment.

**[0041]** FIG. 9 is a diagram showing a wiring structure of the flexible board of the first embodiment.

**[0042]** FIG. 10 is a diagram showing a voltage value of a drive voltage to be applied to each of transmission/reception columns of an ultrasonic device.

**[0043]** FIG. 11 is a plan view, a front view, and a side view of a first reinforcing plate of the first embodiment.

**[0044]** FIG. 12 is a plan view, a front view, and a side view of a second reinforcing plate of the first embodiment.

**[0045]** FIG. 13 is a perspective view of the case in which the flexible board is curved along an X direction in the first embodiment.

**[0046]** FIG. 14 is a side view of an ultrasonic device unit according to the first embodiment viewed from a first inflective part side.

**[0047]** FIG. 15 is a side view of the ultrasonic device unit according to the first embodiment viewed from a second inflective part side.

**[0048]** FIG. 16 is a plan view showing a schematic configuration of a flexible board of a second embodiment of the invention.

[0049] FIG. 17 is an X-Z cross-sectional view of an ultrasonic device unit when curving the flexible board in the second embodiment.

[0050] FIG. 18 is a plan view showing a schematic configuration of a flexible board of a third embodiment of the invention.

[0051] FIG. 19 is an X-Z cross-sectional view of an ultrasonic device unit when curving the flexible board in the third embodiment.

## DESCRIPTION OF EXEMPLARY EMBODIMENTS

### First Embodiment

[0052] A first embodiment according to the invention will hereinafter be described.

[0053] FIG. 1 is a perspective view showing a schematic configuration of the ultrasonic measurement apparatus 1.

[0054] As shown in FIG. 1, the ultrasonic measurement apparatus 1 corresponds to an ultrasonic apparatus, and is provided with an ultrasonic probe 2, and a control device 10 electrically connected to the ultrasonic probe 2 via a cable 3.

[0055] The ultrasonic measurement apparatus 1 transmits an ultrasonic wave from the ultrasonic probe 2 to the inside of a living body (e.g., a human body) in the state in which the ultrasonic probe 2 has contact with a surface of the living body. Further, the ultrasonic measurement apparatus 1 receives the ultrasonic wave reflected by an organ in the living body using the ultrasonic probe 2, and then, for example, obtains an internal tomographic image of the inside of the living body to measure the state (e.g., blood flow) of the organ in the living body based on the received signal.

#### 1. Configuration of Control Device

[0056] As shown in FIG. 1, for example, the control device 10 corresponds to a control section, and is provided with an operating section 11 including buttons or a touch panel, and a display section 12. Further, although not shown in the drawings, the control device 10 is provided with a storage section formed of a memory and so on, and an arithmetic section constituted by a central processing unit (CPU) and so on. The control device 10 makes the arithmetic section execute a variety of programs stored in the storage section to thereby control the ultrasonic measurement apparatus 1. For example, the control device 10 outputs a command for controlling the drive of the ultrasonic probe 2, forms an image of the internal structure of the living body and then makes the display section 12 display the image, and measures the living body information such as the blood flow to make the display section 12 display the living body information based on the received signal input from the ultrasonic probe 2. As such a control device 10, there can be used a terminal device such as a tablet terminal, a smartphone, or a personal computer, and a dedicated terminal device for operating the ultrasonic probe 2 can also be used.

#### 2. Configuration of Ultrasonic Probe

[0057] FIG. 2 is a perspective view showing an appearance of the ultrasonic probe 2. FIG. 3 is a cross-sectional view of the ultrasonic probe 2 cut along the line A-A (a plane

$S_A$ ) shown in FIG. 2, and FIG. 4 is a cross-sectional view of the ultrasonic probe 2 cut along the line B-B (a plane  $S_B$ ) shown in FIG. 2.

[0058] The ultrasonic probe 2 corresponds to an ultrasonic probe, and is provided with a housing 21, and an ultrasonic device unit 4 stored inside the housing 21 as shown in FIG. 1 through FIG. 4. Further, the ultrasonic device unit 4 is configured including an ultrasonic device 5, a flexible printed wiring board (a flexible board 6), a first reinforcing plate 71, and a second reinforcing plate 72.

[0059] Hereinafter, each of the constituents will be described in detail.

#### 2-1. Configuration of Ultrasonic Device 5

[0060] As shown in FIG. 3 and FIG. 4, the ultrasonic device 5 constituting the ultrasonic device unit 4 includes an ultrasonic substrate 51, a sealing plate 52, a wiring board 53, and an acoustic lens 54, and is formed by stacking the wiring board 53, the sealing plate 52, the ultrasonic substrate 51, and the acoustic lens 54 in this order. In the present embodiment, the ultrasonic device 5 is formed to have, for example, a rectangular shape in a planar view viewed from the stacking direction (a Z direction) of the wiring board 53, the sealing plate 52, the ultrasonic substrate 51, and the acoustic lens 54.

##### 2-1-1. Configuration of Ultrasonic Substrate 51

[0061] FIG. 5 is a plan view showing a schematic configuration of the ultrasonic substrate 51 of the present embodiment.

[0062] As shown in FIG. 5, the ultrasonic substrate 51 is provided with a plurality of ultrasonic transducers Tr arranged in a two-dimensional array along the X direction (a second direction, a scanning direction) and the Y direction (a first direction, a slicing direction). In the present embodiment, 1-CH (channel) transmission/reception column Ch (vibrator element) is constituted by a plurality of ultrasonic transducers Tr (ultrasonic elements) arranged in the Y direction. Further, a plurality of the 1-CH transmission/reception columns Ch arranged side by side along the X direction constitutes the ultrasonic substrate 51 having a two-dimensional array structure. Here, in the ultrasonic substrate 51, an area where the ultrasonic transducers Tr are arranged is defined as an array area Ar1.

[0063] It should be noted that in FIG. 5, the number of the ultrasonic transducers Tr arranged is reduced for the sake of convenience of explanation, but in reality, there are arranged a larger number of ultrasonic transducers Tr.

[0064] FIG. 6 is a schematic cross-sectional view of the ultrasonic substrate 51 cut along the line C-C shown in FIG. 5.

[0065] As shown in FIG. 6, the ultrasonic substrate 51 is configured including an element substrate 511, a support film 512 disposed on the element substrate 511, and piezoelectric elements 513 disposed on the support film 512.

[0066] The element substrate 511 is formed of a semiconductor substrate made of, for example, Si. The element substrate 511 is provided with substrate opening parts 511A corresponding to the respective ultrasonic transducers Tr. In the present embodiment, each of the substrate opening parts 511A is a through hole penetrating the element substrate 511

in the thickness direction thereof, and the support film 512 is disposed on one end side (the sealing plate 52 side) of the through hole.

[0067] Further, the side of the substrate opening part 511A where the support film 512 is not provided is filled with an acoustic layer 515 having acoustic impedance approximate to that of the living body.

[0068] Further, on a surface of the element substrate 511 located on the opposite side to the support film 512, there is disposed the acoustic lens 54 having contact with the element substrate 511 and the acoustic layer 515. The acoustic lens 54 is a part which is exposed from the sensor window 211B (see FIG. 1 and so on) provided to the housing 21 when the ultrasonic device unit 4 is stored in the housing 21, and forms a part to have contact with the test object when performing the ultrasonic measurement. Similarly to the acoustic layer 515, the acoustic lens 54 is formed of, for example, silicone having acoustic impedance approximate to that of the living body, and is formed to have a cylindrical shape with an axis parallel to the X direction.

[0069] The support film 512 is formed of, for example, a stacked body of SiO<sub>2</sub> and ZrO<sub>2</sub>, and is disposed so as to cover the entire area on the sealing plate 52 side of the element substrate 511. Specifically, the support film 512 is supported by partition walls 511B constituting the substrate opening parts 511A, and closes the sealing plate 52 side of the substrate opening parts 511A. The thickness dimension of the support film 512 is made sufficiently small with respect to that of the element substrate 511.

[0070] It should be noted that in the present embodiment, the support film 512 is formed by performing a thermal oxidation treatment on one surface of the element substrate 511 formed of Si to form SiO<sub>2</sub>, and then stacking ZrO<sub>2</sub> thereon. On this occasion, by performing etching on the element substrate 511 using the support film 512 including SiO<sub>2</sub> as an etching stopper, it becomes possible to easily form the substrate opening parts 511A and the partition walls 511B.

[0071] The piezoelectric elements 513 are disposed on respective parts of the support film 512 closing the respective substrate opening parts 511A. The piezoelectric elements 513 are each formed of, for example, a stacked body obtained by stacking a lower-part electrode 513A, a piezoelectric film 513B, and an upper-part electrode 513C from the support film 512 side.

[0072] Here, the part of the support film 512 closing the substrate opening part 511A constitutes a vibrating part 512A, and the vibrating part 512A and the piezoelectric element 513 constitute one ultrasonic transducer Tr.

[0073] In such an ultrasonic transducer Tr, by applying a rectangular-wave voltage (a drive voltage) having a predetermined frequency between the lower-part electrode 513A and the upper-part electrode 513C, the piezoelectric film 513B is deflected to vibrate the vibrating part 512A to transmit the ultrasonic wave. Further, when the vibrating part 512A is vibrated by the ultrasonic wave (a reflected wave) reflected by the living body, an electrical potential difference occurs between an upper part and a lower part of the piezoelectric film 513B. Thus, by detecting the electrical potential difference occurring between the lower-part electrode 513A and the upper-part electrode 513C, it becomes possible to detect the ultrasonic wave received.

[0074] As shown in FIG. 5, in the present embodiment, the lower-part electrode 513A is formed along the Y direction to

have a linear shape, and connects the plurality of ultrasonic transducers Tr constituting the 1-CH transmission/reception column Ch to each other. Drive terminals 513D therefor are electrically connected to the wiring board 53 via, for example, through electrodes provided to the sealing plate 52. [0075] Further, the upper-part electrode 513C is formed along the X direction to form a linear shape, and connects the ultrasonic transducers Tr arranged in the X direction. Further, the end parts on the  $\pm X$  sides of the upper-part electrode 513C are respectively connected to common electrode lines 514. The common electrode lines 514 each connect the upper-part electrodes 513C arranged along the Y direction to each other, and are each provided with common terminals 514A at the end parts thereof, wherein the common terminals 514A are electrically connected to the wiring board 53. The common terminals 514A are electrically connected to the wiring board 53 via, for example, through electrodes provided to the sealing plate 52.

#### 2-1-2. Configuration of Sealing Plate 52

[0076] The sealing plate 52 is formed so that the planar shape of the sealing plate 52 viewed from the thickness direction has the same shape as that of, for example, the ultrasonic substrate 51. Further, the sealing plate 52 is bonded with a fixation member such as resin on the support film 512 side of the ultrasonic substrate 51, and at the positions overlapping the partition walls 511B viewed from the substrate thickness direction, to reinforce the ultrasonic substrate 51.

[0077] The sealing plate 52 is provided with openings not shown at positions opposed to the drive terminals 513D and the common terminals 514A of the element substrate 511, and through electrodes 521 (see FIG. 7), for example, for connecting the drive terminals 513D and the common terminals 514A to the wiring board 53 are inserted through the openings.

#### 2-1-3. Configuration of Wiring Board 53

[0078] FIG. 7 is a plan view showing a schematic configuration of the wiring board 53.

[0079] As shown in FIG. 7, the wiring board 53 is provided with device-side terminals (first device-side terminals 531 and second device-side terminals 532) at positions opposed to the drive terminals 513D and the common terminals 514A. These device-side terminals are connected to the drive terminals 513D and the common terminals 514A via the through electrodes 521 provided to the sealing plate 52, respectively.

[0080] In the present embodiment, the drive terminals 513D and the common terminals 514A are disposed in the both end parts in the Y direction. Therefore, also in the wiring board 53, the device-side terminals corresponding to the drive terminals 513D and the common terminals 514A are disposed in the both end parts in the Y direction. Here, the device-side terminals disposed on the  $-Y$  side are referred to as first device-side terminals 531, and the device-side terminals disposed on the  $+Y$  side as the other end side in the Y direction are referred to as second device-side terminals 532.

[0081] Further, in the present embodiment, the number of each of the first device-side terminals 531 and the second device-side terminals 532 provided to the wiring substrate 53 is n (n is an integer equal to or greater than 2). Here, the

first device-side terminal disposed at the  $-X$  side end part is defined as a 1-st first device-side terminal **531**, the second device-side terminal disposed at the  $-X$  side end part is defined as a 1-st second device-side terminal **532**, the first device-side terminal disposed at the  $+X$  side end part is defined as an  $n$ -th first device-side terminal **531**, and the second device-side terminal disposed at the  $+X$  side end part is defined as an  $n$ -th second device-side terminal **532**. The first device-side terminal **531** and the second device-side terminal **532** disposed at “ $i$ ”-th position from the  $-X$  side end part are defined as an  $i$ -th first device-side terminal **531** and an  $i$ -th second device-side terminal **532**.

[0082] To each of the first device-side terminals **531** and the second device-side terminals **532**, there is connected the flexible board **6**.

## 2-2. Configuration of Flexible Printed Wiring Board (Flexible Board 6)

[0083] FIG. 8 is a plan view showing a schematic configuration of a surface of the flexible board **6** of the present embodiment. FIG. 9 is a diagram showing a wiring structure of the flexible board.

[0084] As shown in FIG. 8, the flexible board **6** is formed to have, for example, a rectangular planar shape. The flexible board **6** is divided into five regions along the  $X$  direction.

[0085] Specifically, the flexible board **6** is provided with a device connection section **61** disposed in the central part in the  $X$  direction, a first connector section **62** located on the  $-X$  side of the device connection section **61**, and a second connector section **63** located on the  $+X$  side of the device connection section **61**. Further, the device connection section **61** and the first connector section **62** are linked (connected) to each other via a first inflective part **64**, and the device connection section **61** and the second connector section **63** are linked (connected) to each other via a second inflective part **65**.

### 2-2-1. Description of Device Connection Section 61

[0086] The device connection section **61** is a part to which the ultrasonic device **5** is connected, and has an opening part **611** having a roughly rectangular shape corresponding to the acoustic lens **54**. Further, the device connection section **61** is configured including a first wiring part **612** disposed on the  $-Y$  side of the opening part **611**, and a second wiring part **613** disposed on the  $+Y$  side of the opening part **611**.

[0087] The first wiring part **612** is a part in which interconnections to be connected to the first device-side terminals **531** are disposed, and is provided with a first connection part **614**, a first bending part **615**, and a first device stacking part **616**.

[0088] The first connection part **614** has connection terminals disposed in a connection side **614A** along the  $X$  direction facing the opening part **611**, and connected to the respective first device-side terminals **531** along the connection side **614A**.

[0089] The first bending part **615** is a part extending from the first connection part **614** toward the  $-Y$  side (in a first extending direction). Although the details will be described later, the first bending part **615** is opposed to a bending guide part **715** (see FIG. 4) provided to the first reinforcing plate **71** when bending the flexible board **6**.

[0090] Further, an end edge (a first negative-side end edge **612A**) on the  $-X$  side of the first connection part **614** and the first bending part **615** constitutes a part of an opening edge of a first slit **641** provided to the first inflective part **64** described later. Further, an end edge (a first positive-side end edge **612B**) on the  $+X$  side of the first connection part **614** and the first bending part **615** constitutes a part of an opening edge of a second slit **651** provided to the second inflective part **65** described later.

[0091] The first device stacking part **616** is a part which overlaps the first reinforcing plate **71** when connecting the flexible board **6** to the ultrasonic device **5** supported by the first reinforcing plate **71**, and bending the flexible board **6** around the first bending part **615** along the first reinforcing plate **71**.

[0092] In the present embodiment, as shown in FIG. 9, the interconnections (first interconnections **661**) connected to the 1-st through  $k$ -th first device-side terminals **531** out of the first device-side terminals **531** are disposed in the first device stacking part **616** so as to extend toward the first connector section **62**. Meanwhile, the interconnections (third interconnections **663**) connected to the  $(k+1)$ -th through  $n$ -th first device-side terminals **531** out of the first device-side terminals **531** are disposed in the first device stacking part **616** so as to extend toward the second connector section **63**.

[0093] The second wiring part **613** is a part in which interconnections to be connected to the second device-side terminals **532** are disposed, and has substantially the same configuration as that of the first wiring part **612**. Specifically, the second wiring part **613** is configured line symmetrically with the first wiring part **612** about a  $Y$ -central axis line  $L_Y$  passing through the central point in the  $Y$  direction of the opening part **611** and parallel to the  $X$  direction.

[0094] Specifically, the second wiring part **613** is provided with a second connection part **617**, a second bending part **618**, and a second device stacking part **619**.

[0095] The second connection part **617** has connection terminals disposed along a connection side **617A** along the  $X$  direction facing the opening part **611**, and connected to the respective second device-side terminals **532** along the connection side **617A**.

[0096] The second bending part **618** is a part extending from the second connection part **617** toward the  $+Y$  side (in a second extending direction), and is opposed to the bending guide part **715** of the first reinforcing plate **71** described later when bending the flexible board **6**.

[0097] An end edge (a second negative-side end edge **613A**) on the  $-X$  side of the second connection part **617** and the second bending part **618** constitutes a part of an opening edge of the first slit **641** provided to the first inflective part **64** described later. Further, an end edge (a second positive-side end edge **613B**) on the  $+X$  side of the second connection part **617** and the second bending part **618** constitutes a part of the opening edge of the second slit **651** provided to the second inflective part **65** described later.

[0098] The second device stacking part **619** is a part which overlaps the first reinforcing plate **71** together with the first device stacking part **616** when connecting the flexible board **6** to the ultrasonic device **5** fixed to the first reinforcing plate **71**, and bending the second bending part **618** of the flexible board **6** along the first reinforcing plate **71**.

[0099] Among the interconnections disposed in the second device stacking part **619**, the interconnections (second inter-

connections 662) to be connected to the 1-st through k-th second device-side terminals 532 are disposed so as to extend toward the first connector section 62. Further, the interconnections (fourth interconnections 664) to be connected to the (k+1)-th through n-th second device-side terminals 532 are disposed so as to extend toward the second connector section 63.

#### 2-2-2. Description of First Connector Section 62 and Second Connector Section 63

[0100] The first connector section 62 and the second connector section 63 are disposed on the  $\pm X$  sides of the device connection section 61, respectively, and has a width dimension smaller than the width dimension in the X direction of the device connection section 61.

[0101] The first connector section 62 is provided with a plurality of connectors 621 each provided with a plurality of external connection terminals 622 (see FIG. 9), and the second connector section 63 is provided with a plurality of connectors 631 each provided with a plurality of external connection terminals 632 (see FIG. 9). As shown in FIG. 8 and FIG. 9, in the present embodiment, the first connector section 62 is provided with the three connectors 621, and the second connector section 63 is provided with the three connectors 631. Further, each of the connectors 621 is provided with the external connection terminals 622 to be connected to either of the interconnections 661, 662, and each of the connectors 631 is provided with the external connection terminals 632 to be connected to either of the interconnections 663, 664.

[0102] It should be noted that although in the present embodiment, there is shown an example in which the three connectors 621 (631) are provided, this is not a limitation, and it is also possible to provide one or two connectors 621 (631), or it is also possible to provide four or more connectors 621 (631).

[0103] Here, among the three connectors 621 provided to the first connector section 62, in the connector 621A located on the +X side, there are disposed the 1-st external connection terminal 622 through the  $k_1$ -th ( $k_1 < k$ ) external connection terminal 622. Further, in the connector 621A, the 1-st external connection terminal 622 is disposed at the +X side end part, and the  $k_1$ -th external connection terminal 622 is disposed at the -X side end part.

[0104] Among the three connectors 621 provided to the first connector section 62, in the connector 621B located in the central part in the X direction, there are disposed the ( $k_1 + 1$ )-th external connection terminal 622 through the  $k_2$ -th ( $k_1 < k_2 < k$ ) external connection terminal 622. Further, in the connector 621B, the ( $k_1 + 1$ )-th external connection terminal 622 is disposed at the +X side end part, and the  $k_2$ -th external connection terminal 622 is disposed at the -X side end part.

[0105] Among the three connectors 621 provided to the first connector section 62, in the connector 621C located on the -X side, there are disposed the ( $k_2 + 1$ )-th external connection terminal 622 through the k-th external connection terminal 622. Further, in the connector 621C, the ( $k_2 + 1$ )-th external connection terminal 622 is disposed at the +X side end part, and the k-th external connection terminal 622 is disposed at the -X side end part.

[0106] Therefore, in the first connector section 62, the "i ( $1 \leq i \leq k$ )"-th external connection terminal 622 from the +X side corresponds to the i-th external connection terminal.

[0107] Further, to the i-th external connection terminal 622, there are connected the first interconnection 661 connected to the i-th first device-side terminal 531, and the second interconnection 662 connected to the i-th second device-side terminal 532.

[0108] Here, the first interconnection 661 and the second interconnection 662 disposed in the first connector section 62 are made roughly line-symmetric about the Y-central axis line  $L_Y$  similarly to the device connection section 61. In other words, the wiring length from the first device-side terminal 531 to the external connection terminal 622 in the first interconnection 661 and the wiring length from the second device-side terminal 532 to the external connection terminal 622 in the second interconnection 662 are roughly equal to each other.

[0109] On the other hand, among the three connectors 631 provided to the second connector section 63, in the connector 631A located on the +X side, there are disposed the ( $k+1$ )-th external connection terminal 632 through the  $k_3$ -th ( $k+1 \leq k_3 < n$ ) external connection terminal 632. Further, in the connector 631A, the ( $k+1$ )-th external connection terminal 632 is disposed at the +X side end part, and the  $k_3$ -th external connection terminal 632 is disposed at the -X side end part.

[0110] Among the three connectors 631 provided to the second connector section 63, in the connector 631B located in the central part in the X direction, there are disposed the ( $k_3 + 1$ )-th external connection terminal 632 through the  $k_4$ -th ( $k_3 < k_4 < n$ ) external connection terminal 632. Further, in the connector 631B, the ( $k_3 + 1$ )-th external connection terminal 632 is disposed at the +X side end part, and the  $k_4$ -th external connection terminal 632 is disposed at the -X side end part.

[0111] Among the three connectors 631 provided to the second connector section 63, in the connector 631C located on the -X side, there are disposed the ( $k_4 + 1$ )-th external connection terminal 632 through the n-th external connection terminal 632. Further, in the connector 631C, the ( $k_4 + 1$ )-th external connection terminal 632 is disposed at the +X side end part, and the n-th external connection terminal 632 is disposed at the -X side end part.

[0112] Therefore, in the second connector section 63, the "i ( $k+1 \leq i \leq n$ )"-th external connection terminal 632 from the +X side corresponds to the i-th external connection terminal 632.

[0113] Further, to the i-th external connection terminal 632, there are connected the third interconnection 663 connected to the i-th first device-side terminal 531, and the fourth interconnection 664 connected to the i-th second device-side terminal 532.

[0114] Here, the third interconnection 663 and the fourth interconnection 664 disposed in the second connector section 63 are made roughly line-symmetric about the Y-central axis line  $L_Y$  similarly to the device connection section 61. In other words, the wiring length from the first device-side terminal 531 to the external connection terminal 632 in the third interconnection 663 and the wiring length from the second device-side terminal 532 to the external connection terminal 632 in the fourth interconnection 664 are roughly equal to each other.

[0115] Here, among the first device-side terminals 531, it is preferable for the number (k) of the first device-side terminals 531 to be connected to the external connection terminals 622 of the first connector section 62, and the

number  $(n-k)$  of the first device-side terminals **531** to be connected to the external connection terminals **632** of the second connection section **63** to satisfy the relationship of  $|(n-k)-k|/n \leq 0.2$ .

[0116] In other words, it is preferable to adopt the wiring configuration in which the difference between the number  $(k)$  of the first device-side terminals **531** to be connected to the external connection terminals **622** and the number  $(n-k)$  of the first device-side terminals **531** to be connected to the external connection terminals **632** is equal to or lower than 20% of the total number  $(n)$  of the first device-side terminals **531**. Further, it is more preferable that  $n$  is an even number, and  $k=n/2$  is assumed.

[0117] FIG. 10 is a diagram showing a voltage value of a drive voltage to be applied to each of the transmission/reception columns Ch. In FIG. 10, the dashed-dotted line represents the voltage value in the case of using the flexible board (related art example) having just one connector section with respect to the device connection section, and the solid line represents the voltage value in the present embodiment.

[0118] As shown in FIG. 10, in the past, the device-side terminals located close to the connector section are connected to the external connection terminals located on the device connection section side of the connector section, and the device-side terminals located farther from the connector section are connected to the external connection terminals located farther from the device connection section of the connector section. Therefore, as the device-side terminal is located farther from the connector section, the length of the interconnection also increases, and due to the influence of the voltage drop, the voltage value of the drive voltage applied to each of the transmission/reception columns Ch connected to the device-side terminals also drops.

[0119] In contrast, in the present embodiment, there are provided the first connector section **62** and the second connector section **63** as described above, and the interconnections **661**, **662** are provided to the connector section **62**, and the interconnections **663**, **664** are provided to the connector section **63**, wherein the numbers of the interconnections **661**, **662**, **663**, and **664** are the same. Further, in the present embodiment, the first interconnections **661** and the third interconnections **663** are made roughly line-symmetric about an X-central axis line  $L_x$  passing through the center of the ultrasonic device **5** and parallel to the Y direction, and the second interconnections **662** and the fourth interconnections **664** are made roughly line-symmetric about the X-central axis line  $L_x$ . Therefore, the first interconnection **661** connected to the  $i$ -th first device-side terminal **531**, the second interconnection **662** connected to the  $i$ -th second device-side terminal **532**, the third interconnection **663** connected to the  $(n-i+1)$ -th first device-side terminal **531**, and the fourth interconnection **664** connected to the  $(n-i+1)$ -th second device-side terminal **532** become roughly the same in length, and as shown in FIG. 10, the influence of the voltage drop is suppressed.

### 2-2-3. Configuration of First Inflective Part **64** and Second Inflective Part **65**

[0120] As shown in FIG. 8, the first inflective part **64** is disposed between the device connection section **61** and the first connector section **62**, and links the first connector section **62** to the device connection section **61** in a bendable manner. Similarly, the second inflective part **65** is disposed

between the device connection section **61** and the second connector section **63**, and links the second connector section **63** to the device connection section **61** in a bendable manner. The distance between the device connection section **61** and the first connector section **62** in the first inflective part **64** and the distance between the device connection section **61** and the second connector section **63** in the second inflective part **65** are different from each other.

[0121] The first inflective part **64** has the first slit **641** connected to the opening part **611** provided to the device connection section **61**, and first linking parts **642** connected to the device connection section **61** and the first connector section **62** respectively on the  $\pm Y$  sides of the first slit **641**.

[0122] As shown in FIG. 8, the first slit **641** is an opening elongated along the Y direction (a direction crossing the direction from the device connection section **61** toward the first connector section **62**), and includes the first negative-side end edge **612A**, which is the end edge on the  $-X$  side of the first connection part **614** and the first bending part **615**, and the second negative-side end edge **613A**, which is the end edge on the  $-X$  side of the second connection part **617** and the second bending part **618** as a part of the opening edge on the  $+X$  side. In the present embodiment, the first negative-side end edge **612A** and the second negative-side end edge **613A** are located on a straight line along the Y direction. The opening edge opposed to the first negative-side end edge **612A** and the second negative-side end edge **613A** of the first slit **641** forms a first opposed edge **641A** shaped like a straight line parallel to the Y direction.

[0123] Further, the end edge (a first slit end edge **641B**) on the  $-Y$  side of the first slit **641** links the  $-Y$  side end parts of the first opposed edge **641A** and the first negative-side end edge **612A** to each other, and the end edge (a first slit end edge **641C**) on the  $+Y$  side of the first slit **641** links the  $+Y$  side end parts of the first opposed edge **641A** and the second negative-side end edge **613A** to each other. The first slit end edge **641B** is disposed at a position shifted from the first connection part **614** toward the  $-Y$  side as much as a dimension  $D1$ . Similarly, the first slit end edge **641C** is disposed at a position shifted from the second connection part **617** toward the  $+Y$  side as much as the dimension  $D1$ .

[0124] Here, the dimension  $D1$  is set to a dimension larger than a distance from the wiring board **53** to a first side **71A** (see FIG. 11) of the first reinforcing plate **71** in the case of connecting the flexible board **6** to the ultrasonic device **5** supported by the first reinforcing plate **71** (see FIG. 11) described later.

[0125] The second inflective part **65** has the second slit **651** connected to the opening part **611** provided to the device connection section **61**, and second linking parts **652** connected to the device connection section **61** and the second connector section **63** respectively on the  $\pm Y$  sides of the second slit **651**.

[0126] The second slit **651** has roughly the same configuration as that of the first slit **641**, and is connected to the opening part **611**, including the first positive-side end edge **612B** and the second positive-side end edge **613B** as a part of the opening edge on the  $-X$  side. The opening edge opposed to the first positive-side end edge **612B** and the second positive-side end edge **613B** of the second slit **651** forms a second opposed edge **651A** shaped like a straight line parallel to the Y direction.

[0127] Further, the end edge (a second slit end edge **651B**) on the  $-Y$  side of the second slit **651** links the  $-Y$  side end

parts of the second opposed edge 651A and the first positive-side end edge 612B to each other, and the end edge (a second slit end edge 651C) on the +Y side of the second slit 651 links the +Y side end parts of the second opposed edge 651A and the second positive-side end edge 613B to each other. The second slit end edge 651B is disposed at a position shifted from the first connection part 614 toward the -Y side as much as the dimension D1, and the second slit end edge 651C is disposed at a position shifted from the second connection part 617 toward the +Y side as much as the dimension D1.

[0128] Incidentally, the first device-side terminals 531 to which the first connection part 614 is connected are disposed on the -Y side end part of the ultrasonic device 5, and the second device-side terminals 532 to which the second connection part 617 is connected are disposed on the +Y side end edge of the ultrasonic device 5. The fact that the first slit end edge 641B and the first connection part 614 are distant from each other as much as the dimension D1, and the first slit end edge 641C and the second connection part 617 are distant from each other as much as the dimension D1 means that the width dimension in the Y direction of the first slit 641 is larger than the width dimension in the Y direction of the ultrasonic device 5. Similarly, the width dimension in the Y direction of the second slit 651 is larger than the width dimension in the Y direction of the ultrasonic device 5.

[0129] Here, the dimension from the first negative-side end edge 612A to the first opposed edge 641A and the dimension from the second negative-side end edge 613A to the first opposed edge 641A are the same as each other, and are defined as a width dimension W1 in the X direction in the first slit 641. Further, the dimension from the first positive-side end edge 612B to the second opposed edge 651A and the dimension from the second positive-side end edge 613B to the second opposed edge 651A are the same as each other, and are defined as a width dimension W2 in the X direction in the second slit 651. In the present embodiment, the width dimension W1 of the first slit 641 and the width dimension W2 of the second slit 651 are different from each other, and satisfy  $W1 < W2$ .

### 2-3. Configuration of First Reinforcing Plate 71 and Second Reinforcing Plate 72

#### 2-3-1. Configuration of First Reinforcing Plate 71

[0130] FIG. 11 is a plan view, a front view, and a side view of a first reinforcing plate 71.

[0131] The first reinforcing plate 71 supports the ultrasonic device 5, and is fixed to the housing 21. Further, the first reinforcing plate 71 is formed of a resin material in order to prevent short circuit of the interconnections of the flexible board 6 when the first reinforcing plate 71 has contact with the flexible board 6 connected to the ultrasonic device 5.

[0132] As shown in FIG. 11, the first reinforcing plate 71 has, for example, a roughly rectangular shape in a plan view viewed from the substrate thickness direction, and is provided with a first side 71A (-Y side) and a third side 71C (+Y side) parallel to the X direction, and a second side 71B (-X side) and a fourth side 71D (+X side) parallel to the Y direction.

[0133] The first reinforcing plate 71 is provided with positioning blocks 711 along the second side 71B and the fourth side 71D, respectively. Specifically, there are dis-

posed the positioning block 711 located in an area from a corner part between the first side 71A and the second side 71B through a corner part between the second side 71B and the third side 71C, and the positioning block 711 located in an area from a corner part between the third side 71C and the fourth side 71D through a corner part between the fourth side 71D and the first side 71A. These positioning blocks 711 correspond to reference corner parts, and each function as a positioning part when fixing the first reinforcing plate 71 to the housing 21.

[0134] Each of the positioning blocks 711 is provided with first reference surfaces 711A parallel to the X direction, a second reference surface 711B parallel to the Y direction, and a third reference surface 711C and a fourth reference surface 711D crossing the first reference surfaces 711A and the second reference surface 711B.

[0135] Specifically, the first reference surfaces 711A are  $\pm Y$  side end surfaces of the positioning block 711, and are planes parallel to the X-Z plane.

[0136] The second reference surface 711B is a -X side end surface in the positioning block 711 located on the second side 71B side, and a +X side end surface in the positioning block 711 located on the fourth side 71D side, and is a plane parallel to the Y-Z plane.

[0137] The third reference surface 711C is a +Z side end surface of each of the positioning blocks 711, and has contact with the housing 21. The third reference surface 711C is located on the +Z side with respect to the surface (a fixation surface 712) on the +Z side of the central part of the first reinforcing plate 71. Thus, a step 713 is disposed between the third reference surface 711C and the fixation surface 712, and due to the step 713, the  $\pm X$  side end surfaces of the ultrasonic device 5 are positioned. Here, it is preferable for the height dimension (the dimension in the Z direction) of the step 713 to be equal to or larger than at least the thickness dimension of the flexible board 6.

[0138] The fourth reference surface 711D is a surface forming a reverse surface with respect to the third reference surface 711C, and when housing the ultrasonic device unit 4 in the housing 21, the second reinforcing plate 72 described later is mounted on the fourth reference surface 711D.

[0139] It should be noted that in the present embodiment, the fourth reference surface 711D is disposed in the same plane as the reverse surface 714 as shown in FIG. 11.

[0140] Further, the width dimension W4 in the X direction of the positioning block 711 is smaller than the width dimension W1 of the first slit 641 and the width dimension W2 of the second slit 651 (see FIG. 8).

[0141] Further, in each of the positioning blocks 711, a surface (a surface on the opposite side to the second reference surface 711B) crossing the first side 71A and the third side 71C forms a guide surface 711E. The guide surface 711E is a surface parallel to the Y-Z plane, and has contact with the end edges 612A, 612B, 613A, and 613B when bending the first bending part 615 and the second bending part 618 of the flexible board 6 along the bending guide part 715.

[0142] Further, on the  $\pm Y$  sides of the fixation surface of the first reinforcing plate 71, there are disposed the bending guide parts 715 along the first side 71A and the third side 71C, respectively. The Y-Z cross-section of the bending guide part 715 has an arc-like shape protruding in a direction

of getting away from the fixation surface 712, and continuous with the fixation surface 712 and the reverse surface 714.

[0143] Here, the tip of the protrusion of the bending guide part 715 is located on the fixation surface 712 side of the first reference surface 711A. Specifically, the first reference surfaces 711A located on the both end sides of the first side 71A are located at a position shifted from the -Y side end part of the bending guide part 715 extending along the first side 71A toward the -Y side as much as an amount at least equal to or larger than the thickness of the flexible board 6. Further, the first reference surfaces 711A located on the both end sides of the third side 71C are located at a position shifted from the +Y side end part of the bending guide part 715 extending along the third side 71C toward the +Y side as much as an amount at least equal to or larger than the thickness of the flexible board 6.

[0144] Further, the distance along the X direction between a pair of guide surfaces 711E opposed to each other across the first side 71A is roughly the same as the width dimension W3 in the X direction of the first connection part 614 and the first bending part 615 of the flexible board 6.

[0145] Incidentally, the first reinforcing plate 71 is formed of the resin material as described above, and is therefore lower in strength compared to the case of being formed of, for example, metal. Therefore, in order to increase the substrate strength, the first reinforcing plate 71 is provided with a recessed part 714A disposed on the reverse surface 714, and a metal plate 716 is disposed in the recessed part 714A. The metal plate 716 is disposed on the bottom surface of the recessed part 714A, and does not protrude outward (the -Z side) from the reverse surface 714. Thus, even when bending the flexible board 6 on the reverse surface 714 side of the first reinforcing plate 71, the flexible board 6 and the metal plate 716 do not interfere with each other.

### 2-3-2. Configuration of Second Reinforcing Plate 72

[0146] As shown in FIG. 3 and FIG. 4, the second reinforcing plate 72 supports the second connector section 63.

[0147] FIG. 12 is a plan view, a front view, and a side view of the second reinforcing plate 72.

[0148] As shown in FIG. 12, the second reinforcing plate 72 has a roughly rectangular shape having a fifth side 72A, a sixth side 72B, a seventh side 72C, and an eighth side 72D in a planar view viewed from the plate thickness direction similarly to the first reinforcing plate 71.

[0149] The second reinforcing plate 72 is provided with a connector support surface 721 with which the central part (an area where the connectors 631 are disposed) of the second connector section 63 has contact, and a reverse surface 722 on the opposite side to the connector support surface 721. Further, the second reinforcing plate 72 is provided with second bending guide parts 723 each curved to have an arc-like shape disposed respectively in the fifth side 72A and the seventh side 72C extending along the X direction similarly to the first reinforcing plate 71.

[0150] Further, the second reinforcing plate 72 is provided with second positioning blocks 724 respectively disposed along the sixth side 72B and the eighth side 72D located on the  $\pm X$  sides similarly to the first reinforcing plate 71.

[0151] The second positioning blocks 724 are each provided with a recessed part 724A on a surface on the opposite side to the connector support surface 721. The recessed part 724A forms a configuration space S for the first inflective

part 64 and the second inflective part 65 of the flexible board 6. Specifically, the width dimension D2 in the Y direction of the recessed part 724A of the second positioning block 724 located on the -X side is made larger than the dimension D3 (see FIG. 8) from the -Y side end edge of the first inflective part 64 to the first slit end edge 641B, and the dimension D4 (see FIG. 8) from the +Y side end edge of the first inflective part 64 to the first slit end edge 641C. Further, although not shown in the drawings, the width dimension in the Y direction of the recessed part 724A of the second positioning block 724 located on the +X side is made larger than the dimension D6 (see FIG. 8) from the -Y side end edge of the second inflective part 65 to the second slit end edge 651B, and the dimension D7 (see FIG. 8) from the +Y side end edge of the second inflective part 65 to the second slit end edge 651C.

[0152] Further, on a surface on the opposite side to the connector support surface 721 of the second positioning block 724, there are disposed mount surfaces 724B across the recessed part 724A from each other. The mount surfaces 724B are mounted on the fourth reference surface 711D when storing the second reinforcing plate 72 in the housing 21.

[0153] In the present embodiment, the mount surfaces 724B are located on the -Z side (+Z side when stored in the housing 21) of the reverse surface 722. Thus, when mounting the mount surfaces 724B on the fourth reference surface 711D, between the reverse surface 714 of the first reinforcing plate 71 and the reverse surface 722 of the second reinforcing plate 72, there is formed a space at least equal to or larger than the configuration space S for the flexible board 6 bent multiply and the connectors 621 of the first connector section 62.

[0154] The surface on the fifth side 72A side and on the seventh side 72C side of each of the second positioning blocks 724 forms a second guide surface 724C for guiding the second opposed edge 651A of the second slit 651 of the flexible board 6, and an outer peripheral edge on the -X side of the flexible board 6.

### 2-4. Configuration of Housing 21

[0155] As shown in FIG. 2, the housing 21 is provided with a storage part 211 and a lid part 212.

[0156] As shown in FIG. 3 and FIG. 4, the storage part 211 is a vessel-like member for storing the ultrasonic device unit 4, and has a sensor window 211B in a bottom part 211A, wherein the acoustic lens 54 of the ultrasonic device 5 is exposed to the outside from the sensor window 211B.

[0157] Further, in the bottom part 211A of the storage part 211, there is disposed a device installation part 213 so as to surround the sensor window 211B. The device installation part 213 is formed to have a frame-like shape rising from the bottom part 211A so that four corners of the first reinforcing plate 71 are fitted into the device installation part 213.

### 2-5. Storage of Ultrasonic Device Unit 4 into Housing 21

[0158] In such an ultrasonic probe 2 as described above, firstly, the ultrasonic device 5 is fixed to the fixation surface 712 of the first reinforcing plate 71.

[0159] Then, the first connection part 614 of the flexible board 6 is connected to the -X side of the wiring board 53 of the ultrasonic device 5. Thus, the connection terminals of the first connection part 614 and the first device-side terminals 531 are electrically connected to each other, respectively. Further, the second connection part 617 is connected

to the +X side of the wiring board 53 of the ultrasonic device 5. Thus, the connection terminals of the second connection part 617 and the second device-side terminals 532 are electrically connected to each other, respectively.

[0160] On this occasion, the first negative-side end edge 612A of the flexible board 6 is made to have contact with (be guided by) the guide surface 711E located on the -X side of the first side 71A, and the first positive-side end edge 612B is made to have contact with (be guided by) the guide surface 711E located on the +X side of the first side 71A. Further, the second negative-side end edge 613A of the flexible board 6 is made to have contact with (be guided by) the guide surface 711E located on the -X side of the third side 71C, and the second positive-side end edge 613B is made to have contact with (be guided by) the guide surface 711E located on the +X side of the third side 71C.

[0161] FIG. 13 is a perspective view of the case in which the flexible board 6 is curved along the X direction in the present embodiment.

[0162] Subsequently, the flexible board 6 is curved in a first bending area Ar3 (see FIG. 8) including the first bending part 615 parallel to the X direction to fold back the end edge on the -Y side of the flexible board 6 toward the +Y side. Further, the flexible board 6 is curved in a second bending area Ar4 (see FIG. 8) including the second bending part 618 parallel to the X direction to fold back the end edge on the +Y side of the flexible board 6 toward the -Y side. It should be noted that either one of the first bending area Ar3 and the second bending area Ar4 can be folded back first.

[0163] Here, as shown in FIG. 13, the end edges (the first negative-side end edge 612A and the first positive-side end edge 612B) of the  $\pm X$  sides of the first bending part 615 and the end edges (the second negative-side end edge 613A and the second positive-side end edge 613B) on the  $\pm X$  sides of the second bending part 618 are guided by the guide surfaces 711E to be curved along the arcs of the bending guide parts 715.

[0164] Thus, in the flexible board 6, the first bending area Ar3 can be bent along (in parallel to the X direction) the first side 71A of the first reinforcing plate 71, and thus, the first device stacking part 616 is stacked on the reverse surface 714 side of the first reinforcing plate 71 so as to overlap the first reinforcing plate 71. Further, the second bending area Ar4 can be bent along (in parallel to the X direction) the third side 71C of the first reinforcing plate 71, and thus, the second device stacking part 619 is stacked on the reverse surface 714 side of the first reinforcing plate 71 so as to overlap the first reinforcing plate 71.

[0165] Similarly, in each of the first connector section 62, the first inflective part 64 and the second inflective part 65, an area located on the -Y side of the first bending area Ar3 is made to overlap a central area Ar5. Further, in each of the first connector section 62, the first inflective part 64 and the second inflective part 65, an area located on the +Y side of the second bending area Ar4 is made to overlap the central area Ar5.

[0166] Further, the first bending area Ar3 and the second bending area Ar4 of the second connector section 63 are guided by the second guide surfaces 724C to be curved along the second bending guide parts 723 of the second reinforcing plate 72, and thus, an area located on the -Y side of the first bending area Ar3 of the second connector section

63 and an area located on the +Y side of the second bending area Ar4 are made to overlap the reverse surface of the second reinforcing plate 72.

[0167] As described above, when curving the flexible board 6, the first slit end edges 641B, 641C of the first slit 641 and the second slit end edges 651B, 651C of the second slit 651 move to the positions to be overlapped with the central area Ar5. Therefore, even in the case in which the flexible board 6 is folded back in the first bending area Ar3 and the second bending area Ar4 to be deformed to have a roughly cylindrical shape, in each of the first inflective part 64 and the second inflective part 65, there is formed a shape in which the two first linking parts 642 (the two second linking parts 652 in the second inflective part 65) overlap each other only on the reverse surface 714 side of the first reinforcing plate 71. In other words, the first inflective part 64 and the second inflective part 65 do not form a cylindrical shape, but become to be able to easily be bent toward the reverse surface 714 side of the first reinforcing plate 71.

[0168] Further, in the present embodiment, the width dimension W1 in the X direction of the first slit 641 in the first inflective part 64 is smaller than the width dimension W2 in the X direction of the second slit 651 in the second inflective part 65. Therefore, when bending the first inflective part 64 and second inflective part 65, the first inflective part 64 is bent first, and then the first connector section 62 is overlapped with the first reinforcing plate 71. Here, since the X-width dimension of the first connector section 62 is smaller than the X-width dimension of the first reinforcing plate 71, the first connector section 62 does not project toward the second inflective part 65, and does not hinder bending of the second inflective part 65.

[0169] Further, by bending the first inflective part 64 toward the reverse surface 714 side of the first reinforcing plate 71, the connectors 621 in the first connector section 62 project toward the -Z side.

[0170] Then, the first reinforcing plate 71 is fixed to the storage part 211 of the housing 21.

[0171] Specifically, as shown in FIG. 3 and FIG. 4, the first reference surfaces 711A and the second reference surfaces 711B of the positioning blocks 711 provided to the first reinforcing plate 71 are made to have contact with, and then fitted into, the device installation parts 213 provided to the housing 21. Thus, the third reference surfaces 711C of the first reinforcing plate 71 have contact with the bottom part 211A of the housing 21, and the acoustic lens 54 of the ultrasonic device 5 projects from the sensor window 211B.

[0172] Further, on this occasion, each of the connectors 621 in the first connector section 62 is exposed on the opposite side to the bottom part 211A of the storage part 211. Then, the terminals disposed on the tip of the cable 3 are connected to the connectors 621.

[0173] FIG. 14 is a side view of the ultrasonic device unit 4 housed in the housing 21 viewed from the first inflective part 64 side, and FIG. 15 is a side view viewed from the second inflective part 65 side. It should be noted that the illustration of the second reinforcing plate 72 is omitted in FIG. 14 and FIG. 15.

[0174] Subsequently, the second inflective part 65 is bent to overlap the second reinforcing plate 72 which supports the second connector section 63 with the first reinforcing plate 71. Thus, the mount surfaces 724B of the second positioning blocks 724 of the second reinforcing plate 72 are

mounted on the fourth reference surfaces 711D of the positioning blocks 711 of the first reinforcing plate 71.

[0175] On this occasion, since the width dimension W2 of the second slit 651 in the second inflective part 65 satisfies  $W2 > W1$ , the second connector section 63 does not interfere with the first connector section 62, and the first inflective part 64 and the second inflective part 65 do not project outside as shown in FIG. 14 and FIG. 15, and therefore, miniaturization of the flexible board 6 can be advanced.

[0176] Further, when mounting the mount surfaces 724B of the second reinforcing plate 72 on the fourth reference surfaces 711D of the first reinforcing plate 71, the configuration space S for disposing the flexible board 6 and the first connector section 62 is formed between the reverse surface 714 of the first reinforcing plate 71 and the reverse surface 722 of the second reinforcing plate 72. In the configuration space S, there are disposed the first device stacking part 616, the second device stacking part 619, the first connector section 62 bent to be triply overlapped, the second connector section 63 bent toward the reverse surface 722 side of the second reinforcing plate 72 to be doubly overlapped, the connectors in the first connector section 62, and the terminals of the cable 3 to be connected to the connectors (the illustration of the cable 3 is omitted in FIG. 2 and FIG. 3).

[0177] Further, since the connectors 631 of the second connector section 63 supported by the second reinforcing plate 72 are exposed on the -Z side, the terminals provided to the tip of the cable 3 are connected to the connectors 631. Subsequently, the lid part 212 is fixed to the storage part 211, and the space between the sensor window 211B and the acoustic lens 54 is sealed with a resin material such as silicone resin, and thus, the ultrasonic probe 2 is assembled.

### 3. Functions and Advantages of First Embodiment

[0178] In the ultrasonic device unit 4 according to the present embodiment, the flexible board 6 is provided with the device connection section 61, the first connector section 62, and the second connection section 63, and the device connection section 61 and the first connector section 62 are linked to each other with the first inflective part 64, and the device connection section 61 and the second connector section 63 are linked to each other with the second inflective part 65. Further, the width dimension W1 from the device connection section 61 to the first connector section 62 in the first inflective part 64 becomes smaller than the width dimension W2 from the device connection section 61 through the second connector section 63 in the second inflective part 65.

[0179] In such a configuration, when overlapping the first connector section 62 and the second connector section 63 with the device connection section 61 (the first reinforcing plate 71), the first connector section 62 linked to the first inflective part 64 smaller in width dimension can be disposed on the first reinforcing plate 71 side, and the second connector section 63 linked to the second inflective part 65 larger in width dimension can be disposed on the side farther from the first reinforcing plate 71. Therefore, the interference between the first connector section 62 and the second connector section 63 can be prevented.

[0180] Further, it is not required to double the first inflective part 64 in order to dispose the first connection section 62 on the first reinforcing plate 71 side, but it is possible to dispose the first connector section 62 to a desired position only by curving the first inflective part 64. Therefore, it is

possible to prevent an increase in size due to bending of the first inflective part 64, and the first inflective part 64 is prevented from projecting to the outside of the outer edges of the device connection section 61 and the first reinforcing plate 71, and thus, the miniaturization can be achieved.

[0181] In the present embodiment, the first inflective part 64 is provided with the first slit 641, the second inflective part 65 is provided with the second slit 651, and the width dimension W1 in the X direction of the first slit 641 is smaller than the width dimension W2 of the second slit 651.

[0182] In such a configuration, the first inflective part 64 and the second inflective part 65 become easy to bend with respect to the X direction at positions where the first slit 641 and the second slit 651 are disposed, respectively. Further, since the first slit 641 and the second slit 651 are different in width dimension from each other, it becomes possible to easily dispose the first connector section 62 and the second connector section 63 at positions where the first connector section 62 and the second connector section 63 do not interfere with each other.

[0183] In the present embodiment, the width dimension (the dimension from the first slit end edge 641B to the first slit end edge 641C) in the Y direction of the first slit 641 is larger than the width dimension in the Y direction of the ultrasonic device 5 and the width dimension in the Y direction of the first reinforcing plate 71. Similarly, the width dimension (the dimension from the second slit end edge 651B to the second slit end edge 651C) in the Y direction of the second slit 651 is larger than the width dimension in the Y direction of the ultrasonic device 5 and the width dimension in the Y direction of the first reinforcing plate 71.

[0184] In such a configuration, when curving the flexible board 6 in the first bending area Ar3 and the second bending area Ar4 to form a roughly cylindrical shape, the first slit end edges 641B, 641C and the second slit end edges 651B, 651C are located in the central area Ar5 of the flexible board 6. Therefore, the first inflective part 64 and the second inflective part 65 fail to form a cylindrical shape, but form the shape in which the two first linking part 642 overlapped with each other extend from the reverse surface 714 side of the first reinforcing plate 71 toward the first connector section 62, and the two second linking part 652 overlapped with each other extend from the reverse surface 714 side of the first reinforcing plate 71 toward the second connector section 63. Therefore, compared to the case in which the first inflective part 64 and the second inflective part 65 form a cylindrical shape, the first inflective part 64 and the second inflective part 65 can easily be bent toward the reverse surface side of the first reinforcing plate 71.

[0185] In the present embodiment, the width dimension in the X direction of the first connector section 62 is smaller than the width dimension in the X direction of the first reinforcing plate 71 which supports the device connection section 61. Further, the width dimension in the X direction of the second connector section 63 is smaller than the width dimension in the X direction of the first reinforcing plate 71 which supports the device connection section 61.

[0186] Therefore, in the case of curving the flexible board 6 in the first inflective part 64 to bend the flexible board 6, the end parts of the first connector section 62 do not project toward the +X side from the third side 71C of the first reinforcing plate 71, and thus do not hinder the curve of the second inflective part 65. Further, in the case of curving the flexible board 6 in the second inflective part 65 to bend the

flexible board 6, the end parts of the second connector section 63 do not project toward the -X side from the first side 71A of the first reinforcing plate 71. Therefore, it is possible to achieve the miniaturization of the ultrasonic device unit 4 in the case of curving the flexible board 6 to overlap the first connector section 62 and the second connector section 63 with the first reinforcing plate 71 (the device connecting section 61).

[0187] In the present embodiment, in the flexible board 6, there are arranged the first connector section 62, the device connecting section 61, and the second connector section 63 in this order along the X direction.

[0188] In such a configuration, the first interconnections 661 and the second interconnections 662 extending from the device connection section 61 toward the first connection section 62, and the third interconnections 663 and the fourth interconnections 664 extending from the device connection section 61 toward the second connection section 63 can be formed roughly line-symmetrically with each other. Therefore, even in the case in which the voltage drop occurs, the transmission/reception efficiency of the ultrasonic wave output from the first connector section 62 side in the ultrasonic device 5 and the transmission/reception efficiency of the ultrasonic wave output from the second connector section 63 side become roughly equal to each other. Therefore, it is prevented that the transmission/reception efficiency of the ultrasonic wave significantly lowers in a part of the ultrasonic device 5, and the appropriate transmission/reception process of the ultrasonic wave can be performed.

#### Second Embodiment

[0189] In the first embodiment described above, there is shown the configuration in which the first connector section 62 is disposed on the -X side of the device connection section 61, and the second connector section 63 is disposed on the +X side of the device connection section 61 in the flexible board 6. In contrast, the second embodiment is different from the first embodiment described above in the point that the position of the second connector section 63 is different. It should be noted that in the following description, the constituents having already been described are denoted by the same reference symbols, and the description thereof will be omitted or simplified.

[0190] FIG. 16 is a plan view showing a flexible board 6A of the second embodiment.

[0191] FIG. 17 is an X-Z cross-sectional view of an ultrasonic device unit 4 when curving the flexible board 6A in the second embodiment.

[0192] As shown in FIG. 16, in the flexible board 6A of the second embodiment, the device connection section 61 is disposed on the +X side end part of the flexible board 6A. Further, the first connector section 62 is disposed on the -X side of the device connection section 61 via the first inflective part 64.

[0193] Further, in the present embodiment, a second connector section 67 is disposed on the -X side of the first connector section 62, wherein the second connector section 67 is linked to the first connector section 62 via a third inflective part 68.

[0194] Similarly to the second connector section 63 in the first embodiment, the second connector section 67 includes a plurality of (e.g., three) connectors 671, and a plurality of external connection terminals (not shown) is disposed in these connectors 671. Further, similarly to the second con-

connector section 63 of the first embodiment, to the external connection terminals disposed in the second connector section 67, there are connected, for example, the (k+1)-th through n-th device-side terminals (the first device-side terminals 531 and the second device-side terminals 532) of the ultrasonic device 5.

[0195] Further, similarly to the first embodiment, the first inflective part 64 is provided with the first slit 641 having the width dimension in the X direction of W1, and is provided with the first linking parts 642 for connecting the device connection section 61 and the first connector section 62 to each other, respectively on the ±Y sides.

[0196] Meanwhile, the third inflective part 68 is provided with a third slit 681 having the width dimension in the X direction of W3, and is provided with third linking parts 682 for linking the first connector section 62 and the second connector section 67 to each other, respectively on the ±Y sides of the third slit 681.

[0197] Here, in the present embodiment, the width dimension W3 (=the width dimension in the X direction of the third slit 681) in the X direction of the third inflective part 68 is larger than the width dimension W1 (=the width dimension in the X direction of the first slit 641) in the X direction of the first inflective part 64. Therefore, the first connector section 62 and the second connector section 67 do not interfere with each other, and a sufficient space for connecting the wiring terminals to the connectors 621, 671 can be formed.

[0198] Specifically, in the case of storing the ultrasonic device unit 4 in the housing 21 in the present embodiment, firstly, the device connection section 61 is connected to the first reinforcing plate 71 similarly to the first embodiment. Then, the flexible board 6A is curved in the first bending area Ar3 and the second bending area Ar4. On this occasion, in the present embodiment, the second reinforcing plate 72 is made to support the second connector section 67.

[0199] Then, the first inflective part 64 is bent to thereby overlap the first connector section 62 with the first reinforcing plate 71.

[0200] Subsequently, the third inflective part 68 is bent so as to sandwich the first connector section 62 between the second connector section 67 and the first reinforcing plate 71 to thereby overlap the second connector section 67 with the first reinforcing plate 71.

[0201] On this occasion, since the width dimension W3 in the X direction of the third inflective part 68 satisfies  $W3 > W1$ , the second connector section 67 does not interfere with the first connector section 62, and at the same time, the configuration space S with a predetermined distance is formed between the second connector section 67 and the first connector section 62 as shown in FIG. 17. Therefore, the connectors 621 of the first connector section 62 and the connectors 671 of the second connector section 67 are exposed in the configuration space S, and thus, connection of the wiring terminals to the connectors 621, 671 becomes easy.

[0202] Further, since the second connector section 67 is held by the second reinforcing plate 72, by mounting the mount surfaces 724B of the second positioning blocks 724 of the second reinforcing plate 72 on the fourth reference surfaces 711D of the positioning blocks 711, the configuration space S is maintained similarly to the first embodiment.

### Functions and Advantages of Second Embodiment

[0203] In the present embodiment, the flexible board 6A is provided with the first connector section 62 disposed on the -X side of the device connection section 61 via the first inflective part 64, and the second connector section 67 disposed on the -X side of the first connector section 62 via the third inflective part 68. Further, the distance (the width dimension W1 in the X direction of the first inflective part 64) from the device connection section 61 to the first connector section 62 is smaller than the distance (the width dimension W3 in the X direction of the third inflective part 68) from the first connector section 62 to the second connector section 67.

[0204] In such a configuration, when overlapping the first connector section 62 and the second connector section 67 with the first reinforcing plate 71 for supporting the device connection section 61, the first inflective part 64 is curved to overlap the first connector section 62 with the device connection section 61. Then, the third inflective part 68 is curved to overlap the second connector section 67 with the opposite side to the device connection section 61 (the first reinforcing plate 71) of the first connector section 62. Thus, the device connection section 61, the first connector section 62, and the second connector section 67 are differently disposed from each other with respect to the Z direction as a result, and can be prevented from interfering with each other. Further, since  $W3 > W1$  is satisfied, the configuration space S in which the connectors 621 of the first connector section 62 are disposed can sufficiently be ensured, and thus, it is possible to easily connect the wiring terminals to the connectors 621.

### Third Embodiment

[0205] Then, a third embodiment will be described.

[0206] In the second embodiment described above, there is shown the example in which the width dimension W1 of the first inflective part 64 and the width dimension W3 of the third inflective part 68 have the relationship of  $W1 < W3$ . In contrast, the present embodiment is different from the second embodiment described above in the point that  $W3 < W1$  is true.

[0207] FIG. 18 is a plan view showing a flexible board 6B of the third embodiment.

[0208] FIG. 19 is an X-Z cross-sectional view of the ultrasonic device unit 4 when curving the flexible board 6B in the third embodiment.

[0209] Similarly to the second embodiment, the flexible board 6B in the third embodiment is provided with the first connector section 62 disposed on the -X side of the device connection section 61 via the first inflective part 64, and the second connector section 67 disposed on the -X side of the first connector section 62 via the third inflective part 68.

[0210] Further, in the present embodiment, the distance (the width dimension W1 in the X direction of the first inflective part 64) from the device connection section 61 to the first connector section 62 is larger than the distance (the width dimension W3 in the X direction of the third inflective part 68) from the first connector section 62 to the second connector section 67.

[0211] In such a configuration, in the case of storing the ultrasonic device unit 4 in the housing 21, the device connection section 61 is connected to the first reinforcing plate 71, and then, the flexible board 6B is curved in the first

bending area Ar3 and the second bending area Ar4 similarly to the first embodiment described above. On this occasion, in the present embodiment, the second reinforcing plate 72 is made to support the first connector section 62.

[0212] Then, the third inflective part 68 is bent to thereby overlap the second connector section 67 with the first connector section 62. On this occasion, the external connection terminals of the connectors 671 of the second connector section 67 are exposed on the opposite side to the first connector section 62.

[0213] Subsequently, the first inflective part 64 is bent to thereby overlap the first connector section 62 with the first reinforcing plate 71. Since the second connector section 67 has been bent so as to overlap the first connector section 62, when curving the first inflective part 64, the second connector section 67 is disposed between the first connector section 62 and the device connection section 61 (the first reinforcing plate 71).

[0214] Here, since the width dimension W1 in the X direction of the first inflective part 64 satisfies  $W1 > W3$ , as shown in FIG. 19, the second connector section 67 and the device connection section 61 (the first reinforcing plate 71) do not interfere with each other. Further, the connectors 671 of the second connector section 67 are exposed in the configuration space S between the first connector section 62 and the first reinforcing plate 71, and thus, connection of the wiring terminals to the connectors 671 becomes easy.

[0215] Further, since the first connector section 62 is held by the second reinforcing plate 72, by mounting the mount surfaces 724B of the second positioning blocks 724 of the second reinforcing plate 72 on the fourth reference surfaces 711D of the positioning blocks 711, the configuration space S is maintained similarly to the first embodiment.

### Functions and Advantages of Third Embodiment

[0216] In the present embodiment, the flexible board 6B is provided with the first connector section 62 disposed on the -X side of the device connection section 61 via the first inflective part 64, and the second connector section 67 disposed on the -X side of the first connector section 62 via the third inflective part 68. Further, the width dimension W1 in the X direction of the first inflective part 64 is larger than the width dimension W3 in the X direction of the third inflective part 68.

[0217] In such a configuration, when overlapping the first connector section 62 and the second connector section 67 with the first reinforcing plate 71 for supporting the device connection section 61, the third inflective part 68 is curved to overlap the second connector section 67 with the first connector section 62. Then, the first inflective part 64 is curved to overlap the first connector section 62, with which the second connector section 67 is overlapped, with the device connection section 61 (the first reinforcing plate 71). Thus, the device connection section 61, the first connector section 62, and the second connector section 67 are disposed at respective positions different from each other with respect to the Z direction as a result, and can be prevented from interfering with each other. Further, since  $W3 < W1$  is satisfied, a space in which the connectors 671 of the second connector section 67 and the wiring terminals can be disposed can sufficiently be ensured in the configuration space S.

## Modified Examples

[0218] It should be noted that the invention is not limited to each of the embodiments and the modified examples described above, but includes modifications and improvements within a range in which the advantages of the invention can be achieved, and configurations, which can be obtained by, for example, arbitrarily combining the embodiments.

[0219] In the embodiments described above, there is shown the configuration example in which the device connection section 61, the first connector section 62, and the second connector section 63 (or the second connector section 67) are disposed along the X direction of the flexible board 6, but this is not a limitation.

[0220] For example, it is also possible to dispose the first connector section 62 on the -Y side of the device connection section 61, and dispose the second connector section 63 on the +Y side. Further, it is also possible to dispose the first connector section 62 on the -X side of the device connection section 61, and dispose the second connector section 63 on the +Y side. In either cases, by making the distance between the device connection section 61 and the first connector section 62 in the first inflective part 64, and the distance between the device connection section 61 and the second connector section 63 in the second inflective part 65 different from each other, substantially the same functions and advantages as those of the embodiments described above can be exerted.

[0221] Further, there is shown the example in which the two connector sections 62, 63 are provided with respect to the device connection section 61, but this example is not a limitation, and it is also possible to provide three or more connector sections. Also in this case, there is adopted a configuration in which the distances of the connector sections from the device connection section 61 are different from each other. According to this configuration, the interference between the connector sections can be prevented.

[0222] In the embodiments described above, there is shown the configuration in which the first inflective part 64 and the second inflective part 65 are respectively provided with the slits 641, 651 each having the width dimension larger than that of the ultrasonic device 5 (the first reinforcing plate 71) in the width dimension in the Y direction, this configuration is not a limitation.

[0223] It is also possible to adopt, for example, a configuration in which no slit is provided to the first inflective part 64 and the second inflective part 65, or a configuration in which there is disposed a slit shorter in width dimension than the first reinforcing plate 71. It should be noted that in the case in which no slit exists, when curving the flexible board 6 in the first bending area Ar3 and the second bending area Ar4, the first inflective part 64 and the second inflective part 65 form a roughly cylindrical shape, and thus, the configuration becomes hard to be curved. Further, if the width dimension in the Y direction of the slit is shorter than the first reinforcing plate 71, the first reinforcing plate 71 functions as a sidewall for hindering the curve. Therefore, in these cases, it is preferable to fold the first inflective part 64 and the second inflective part 65 in the first bending area Ar3 or the second bending area Ar4 to thereby form a roughly flat plane to deform them into a shape easy to curve.

[0224] In the embodiments described above, there is illustrated the configuration in which the connectors 621 provided to the first connector section 62 and the connectors

631 provided to the second connector section 63 each have a long side parallel to the X direction, and the external connection terminals 622, 632 are arranged in the X direction, but this configuration is not a limitation. It is also possible for the connectors 621, 631 and the external connection terminals 622, 632 to be arranged along, for example, the Y direction. Further, the number of the connectors 621, 631 disposed in each of the connector sections 62, 63 is not particularly limited, and can be 1 or 2, or it is also possible to dispose four or more connectors.

[0225] There is shown the example in which the width dimension in the X direction of the first connector section 62 and the second connector section 63 is shorter than the width dimension in the X direction of the device connection section 61, but this example is not a limitation. For example, it is also possible that the width dimension in the X direction of the first connector section 62 and the second connector section 63 is longer than the width dimension in the X direction of the device connection section 61. In this case, by, for example, folding back a part of the end part on the opposite side to the device connection section 61 of the first connector section 62 and the second connector section 63, it is possible to configure the first connector section 62 and the second connector section 63 so as not to project from the device connection section 61 in the planar view.

[0226] In the embodiments described above, there is shown the example in which the ultrasonic device 5 is provided with the wiring board 53, and the wiring board 53 is provided with the device-side terminals to be connected to the respective terminals 513D, 514A provided to the ultrasonic substrate 51. In contrast, it is also possible to adopt a configuration in which the wiring board 53 is not provided, and the first connection part 614 and the second connection part 617 of the flexible board 6 are directly connected to the terminals 513D, 514A of the ultrasonic substrate 51.

[0227] In the embodiments described above, there is shown the example in which the ultrasonic device 5 transmits the ultrasonic wave from the substrate opening part 511A, and receives the ultrasonic wave entering the substrate opening part 511A. In contrast, it is also possible to adopt a configuration in which the sealing plate 52 is disposed on the substrate opening part 511A side, and the ultrasonic wave is output to the opposite side to the substrate opening part 511A.

[0228] Further, the transmission/reception column Ch provided with a plurality of ultrasonic transducers Tr is illustrated as the vibrator element provided to the ultrasonic device 5, but this example is not a limitation. For example, it is also possible that each of the ultrasonic transducers Tr can also be configured as a vibrator element.

[0229] Further, there is shown an example of the ultrasonic transducer Tr in which the ultrasonic wave is transmitted by vibrating the support film 512 with the piezoelectric element 513, and the ultrasonic wave is received by converting the vibration of the support film 512 into an electric signal with the piezoelectric element 513, but this example is not a limitation. For example, it is also possible to adopt a configuration in which the ultrasonic wave is transmitted and received by vibrating as bulk-type piezoelectric body, and further, it is also possible to adopt a configuration in which electrodes opposed to each other are provided to a pair of film members, and a cyclic drive voltage is applied between the electrodes to thereby vibrate the film members using electrostatic force.

[0230] In each of the embodiments described above, the ultrasonic measurement apparatus 1 taking an organ in a living body as the measurement object is illustrated as the ultrasonic apparatus, but this is not a limitation. For example, the configurations of the embodiments and the modified examples described above can be applied to a measurement apparatus taking a variety of types of structures as the measurement object, and performing detection of defects of the structures and inspections of aging of the structures. Further, the same applies to a measurement apparatus taking, for example, a semiconductor package or a wafer as the measurement object, and detecting the defects of the measurement object.

[0231] Besides the above, specific structures to be adopted when implementing the invention can be configured by arbitrarily combining the embodiments and the modified examples described above with each other, or can arbitrarily be replaced with other structures and so on within the range in which the advantages of the invention can be achieved.

[0232] The entire disclosure of Japanese Patent Application No. 2017-055390 filed Mar. 22, 2017 is expressly incorporated by reference herein.

What is claimed is:

1. An ultrasonic device unit comprising:
  - an ultrasonic device; and
  - a flexible printed wiring board to be connected to the ultrasonic device,
 wherein the flexible printed wiring board is provided with
  - a device connection section to which the ultrasonic device is connected,
  - a first connector section including a plurality of external connection terminals to be connected to the ultrasonic device,
  - a second connector section including a plurality of external connection terminals to be connected to the ultrasonic device,
  - a first inflective part disposed between the device connection section and the first connector section, and adapted to link the device connection section and the first connector section to each other, and
  - a second inflective part disposed between the device connection section and the second connector section, and adapted to link the device connection section and the second connector section to each other, and
  - a distance between the device connection section and the first connector section in the first inflective part and a distance between the device connection section and the second connector section in the second inflective part are different from each other.
2. The ultrasonic device unit according to claim 1, wherein
  - the first inflective part is provided with a first slit,
  - the second inflective part is provided with a second slit, and
  - a width dimension in a direction from the device connection section toward the first connector section of the first slit, and a width dimension in a direction from the device connection section toward the second connector section of the second slit are different from each other.
3. The ultrasonic device unit according to claim 2, wherein
  - a width dimension in a direction crossing the direction from the device connection section toward the first connector section of the first slit is larger than a width

dimension in the direction crossing the direction from the device connection section toward the first connector section of the ultrasonic device, and

- a width dimension in a direction crossing the direction from the device connection section toward the second connector section of the second slit is larger than a width dimension in the direction crossing the direction from the device connection section toward the second connector section of the ultrasonic device.

4. The ultrasonic device unit according to claim 1, wherein

- a width dimension in the direction from the device connection section toward the first connector section of the first connector section is smaller than a width dimension in the direction from the device connection section toward the first connector section of the device connection section, and

- a width dimension in the direction from the device connection section toward the second connector section of the second connector section is smaller than a width dimension in the direction from the device connection section toward the second connector section of the device connection section.

5. The ultrasonic device unit according to claim 1, wherein

- the device connection section, the first connector section, and the second connector section are arranged in a first direction, and

the device connection section is located between the first connector section and the second connector section.

6. An ultrasonic device unit comprising:

- an ultrasonic device; and
- a flexible printed wiring board to be connected to the ultrasonic device,

wherein the flexible printed wiring board is provided with

- a device connection section to which the ultrasonic device is connected,

- a first connector section including a plurality of external connection terminals to be connected to the ultrasonic device,

- a second connector section including a plurality of external connection terminals to be connected to the ultrasonic device,

- a first inflective part disposed between the device connection section and the first connector section, and adapted to link the device connection section and the first connector section to each other, and

- a third inflective part disposed between the first connector section and the second connector section, and adapted to link the first connector section and the second connector section to each other, and

a distance between the device connection section and the first connector section in the first inflective part and a distance between the first connector section and the second connector section in the third inflective part are different from each other.

7. An ultrasonic probe comprising:

- the ultrasonic device unit according to claim 1; and
- a housing adapted to store the ultrasonic device unit.

8. An ultrasonic probe comprising:

- the ultrasonic device unit according to claim 2; and
- a housing adapted to store the ultrasonic device unit.

9. An ultrasonic probe comprising:  
the ultrasonic device unit according to claim 3; and  
a housing adapted to store the ultrasonic device unit.
10. An ultrasonic probe comprising:  
the ultrasonic device unit according to claim 4; and  
a housing adapted to store the ultrasonic device unit.
11. An ultrasonic probe comprising:  
the ultrasonic device unit according to claim 5; and  
a housing adapted to store the ultrasonic device unit.
12. An ultrasonic probe comprising:  
the ultrasonic device unit according to claim 6; and  
a housing adapted to store the ultrasonic device unit.
13. An ultrasonic apparatus comprising:  
the ultrasonic device unit according to claim 1; and  
a control section adapted to control the ultrasonic device unit.
14. An ultrasonic apparatus comprising:  
the ultrasonic device unit according to claim 2; and  
a control section adapted to control the ultrasonic device unit.

15. An ultrasonic apparatus comprising:  
the ultrasonic device unit according to claim 3; and  
a control section adapted to control the ultrasonic device unit.
16. An ultrasonic apparatus comprising:  
the ultrasonic device unit according to claim 4; and  
a control section adapted to control the ultrasonic device unit.
17. An ultrasonic apparatus comprising:  
the ultrasonic device unit according to claim 5; and  
a control section adapted to control the ultrasonic device unit.
18. An ultrasonic apparatus comprising:  
the ultrasonic device unit according to claim 6; and  
a control section adapted to control the ultrasonic device unit.

\* \* \* \* \*

专利名称(译)	超声波装置单元，超声波探头和超声波装置		
公开(公告)号	<a href="#">US20180271486A1</a>	公开(公告)日	2018-09-27
申请号	US15/921992	申请日	2018-03-15
[标]申请(专利权)人(译)	精工爱普生株式会社		
申请(专利权)人(译)	SEIKO EPSON CORPORATION		
当前申请(专利权)人(译)	SEIKO EPSON CORPORATION		
[标]发明人	YOSHIDA KAZUKI		
发明人	YOSHIDA, KAZUKI		
IPC分类号	A61B8/00 H05K1/18		
CPC分类号	A61B8/4455 A61B8/4494 A61B8/54 A61B8/461 H05K1/189 A61B8/06 A61B8/4427 H05K1/028 H05K2201/09063		
优先权	2017055390 2017-03-22 JP		
外部链接	<a href="#">Espacenet</a> <a href="#">USPTO</a>		

摘要(译)

超声波装置单元包括超声波装置和与超声波装置连接的柔性印刷布线板，柔性印刷布线板设置有与超声波装置连接的装置连接，第一连接器包括外部连接端子。连接到超声装置的第二连接器，包括连接到超声装置的外部连接端子的第二连接器，适于将装置连接和第一连接器彼此连接的第一可选部分，以及适于连接装置的第二可选部分连接和第二连接器彼此连接，并且第一可弯曲部分中的设备连接和第一连接器之间的距离以及第二可弯曲部分中的设备连接和第一连接器之间的距离彼此不同。

