



US 20150045670A1

(19) **United States**

(12) **Patent Application Publication**
Davidson et al.

(10) **Pub. No.: US 2015/0045670 A1**
(43) **Pub. Date: Feb. 12, 2015**

(54) **ULTRASONIC MATRIX ARRAY PROBE WITH THERMALLY DISSIPATING CABLE**

Publication Classification

(71) Applicant: **KONINKLIJKE PHILIPS N.V.**,
EINDHOVEN (NL)
(72) Inventors: **Richard Edward Davidson**, Andover,
MA (US); **Michael Scarsela**, Amesbury,
MA (US); **James Christopher Taylor**,
State College, PA (US); **Andrew Lee**
Robinson, Bellevue, WA (US)

(51) **Int. Cl.**
A61B 8/00 (2006.01)
(52) **U.S. Cl.**
CPC *A61B 8/4444* (2013.01); *A61B 8/4494*
(2013.01)
USPC **600/459**

(21) Appl. No.: **14/386,035**
(22) PCT Filed: **Mar. 12, 2013**
(86) PCT No.: **PCT/IB2013/051939**
§ 371 (c)(1),
(2) Date: **Sep. 18, 2014**

(57) **ABSTRACT**

A matrix array probe including a transducer array and integrated circuitry coupled to the transducer elements dissipates heat generated by the array and integrated circuitry through the cover of the transducer probe. A pump in the probe connector pumps fluid through a closed loop system including inbound an outbound fluid conduits in the cable. The fluid conduits in the cable are separated by the cable electrical conductors for the probe. The heat transfer in the probe is done by a heat exchanger in the probe spaceframe or transducer stack backing block and may use a Peltier device. Additional cooling may be provided by metal to metal contact with a chiller in the ultrasound system.

Related U.S. Application Data

(60) Provisional application No. 61/613,071, filed on Mar. 20, 2012.

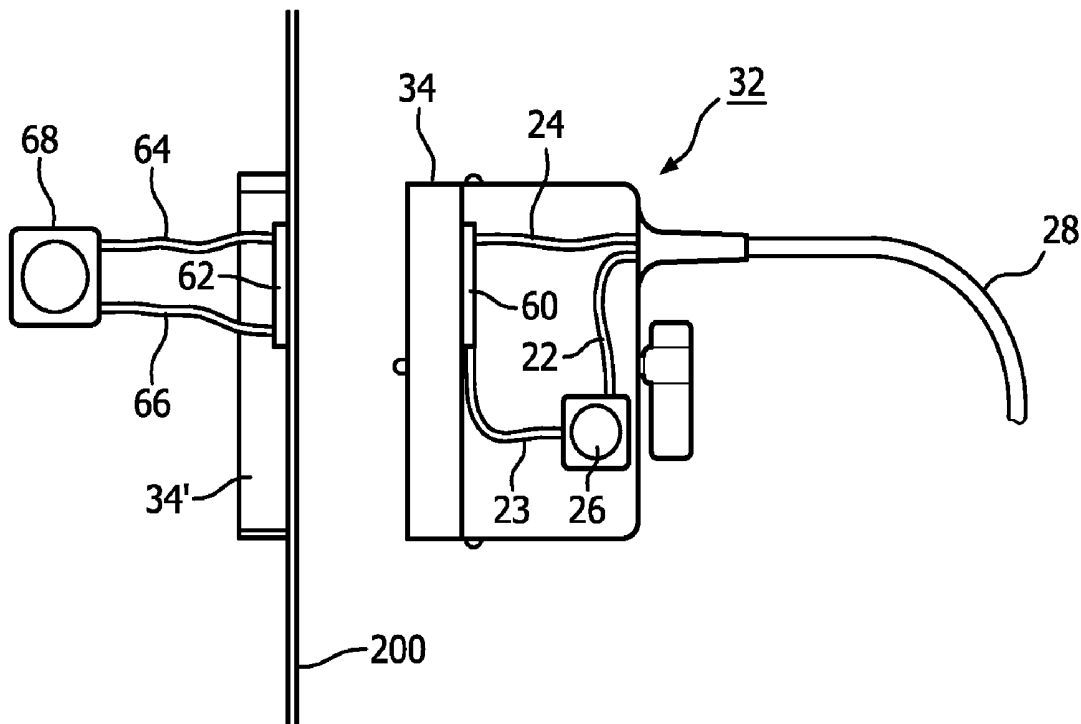

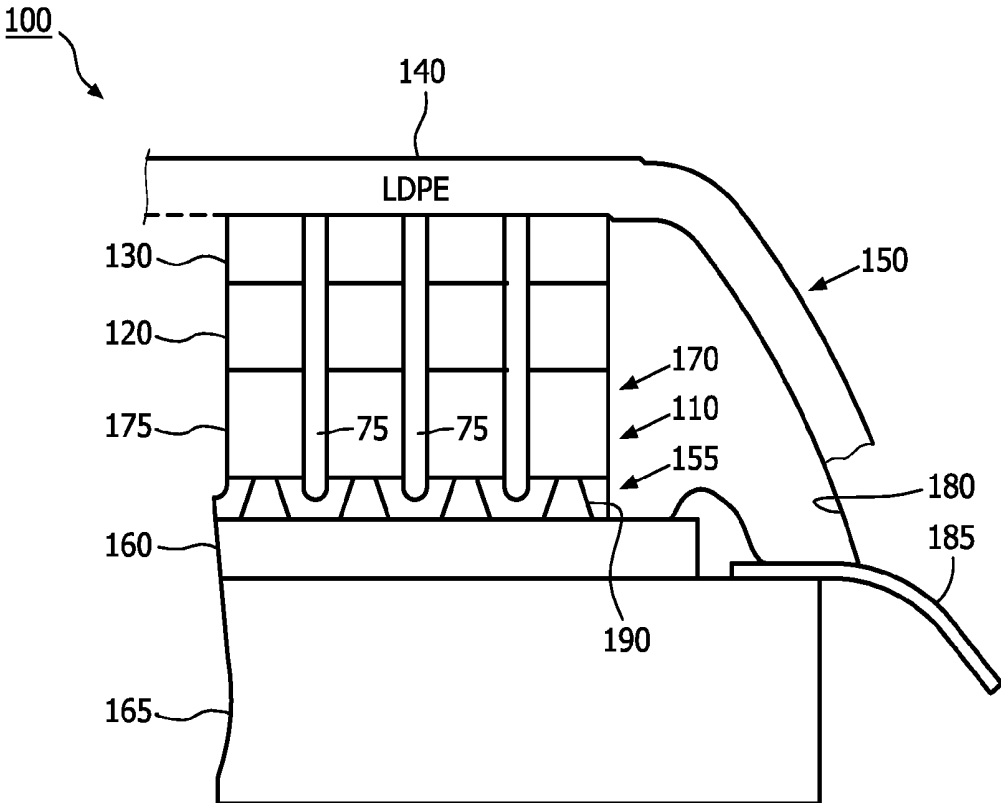

FIG. 1

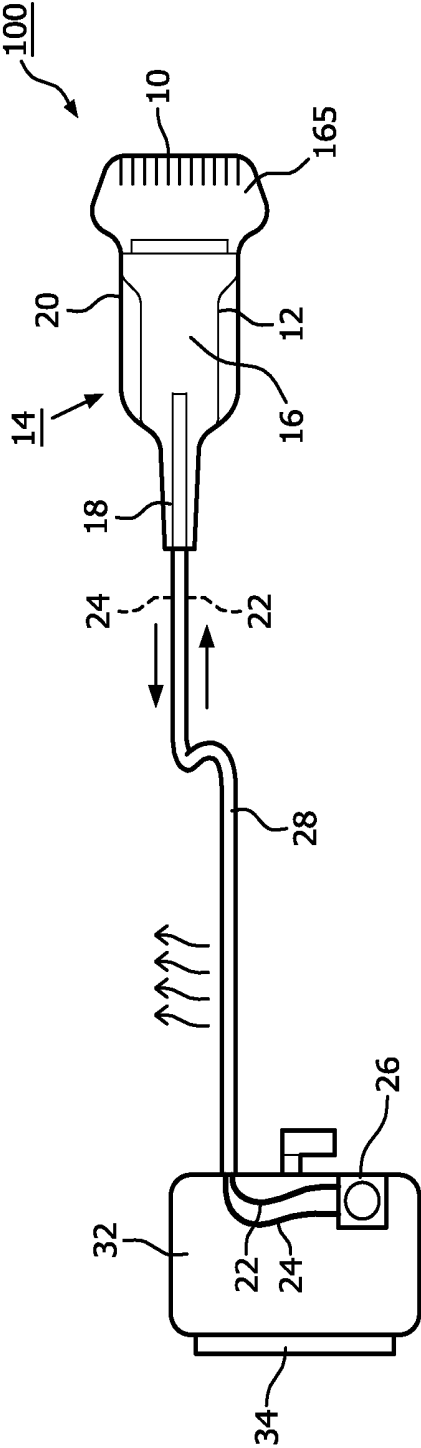

FIG. 2

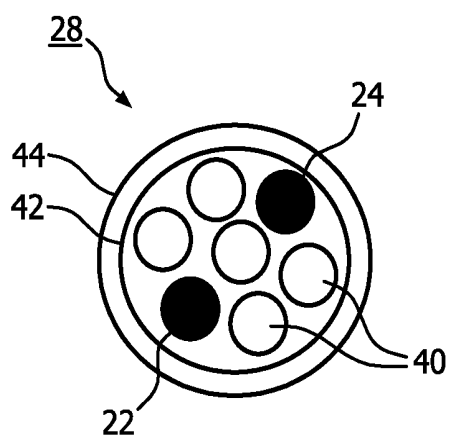

FIG. 3

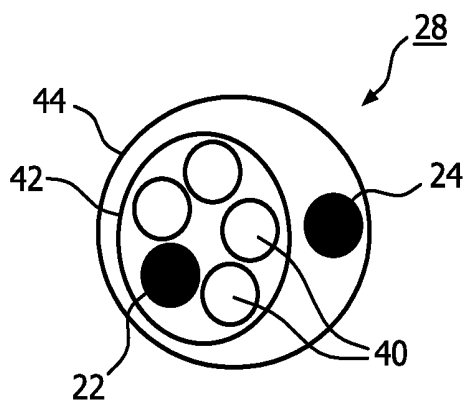

FIG. 4

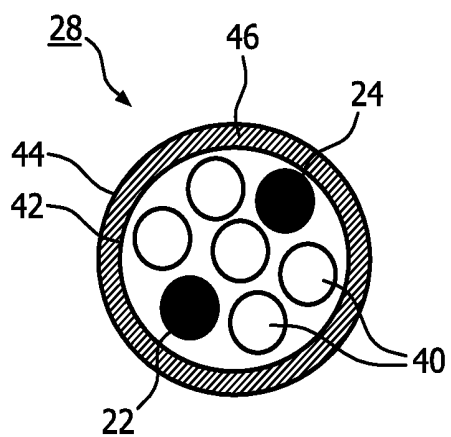

FIG. 5

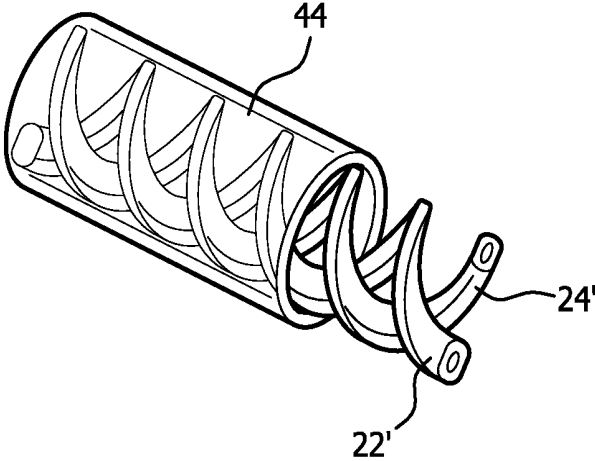

FIG. 6

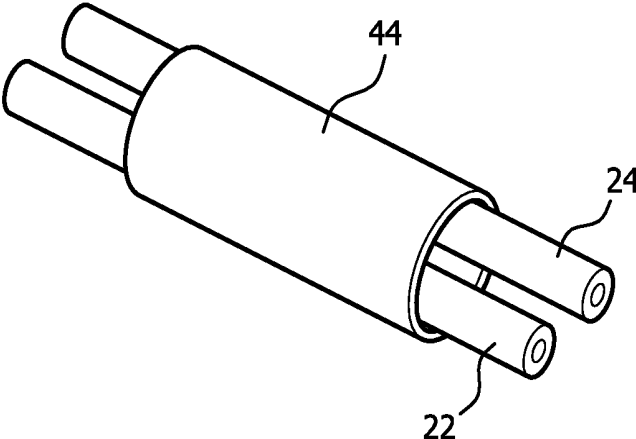

FIG. 7

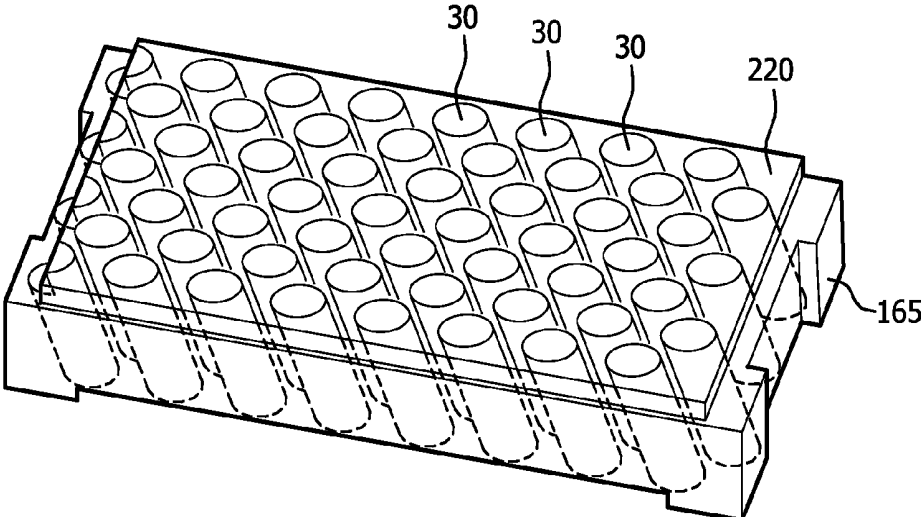

FIG. 8

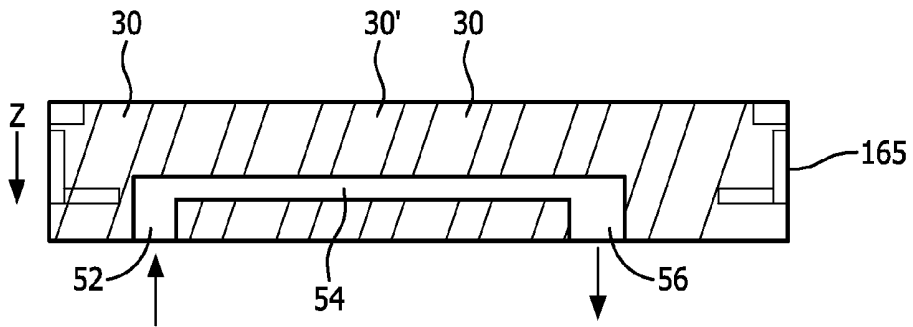

FIG. 9

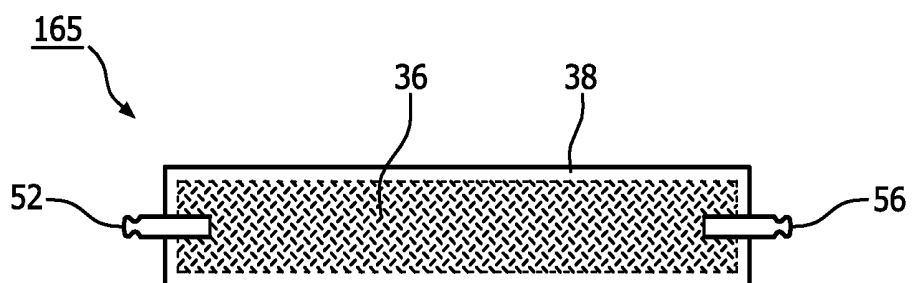

FIG. 10

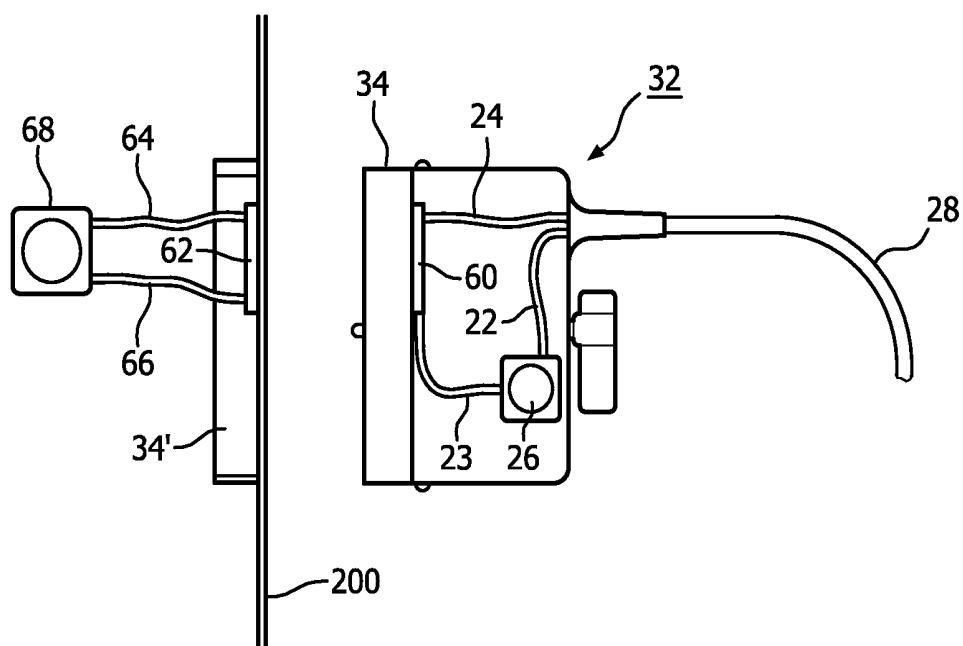

FIG. 11

ULTRASONIC MATRIX ARRAY PROBE WITH THERMALLY DISSIPATING CABLE

[0001] This invention relates to medical diagnostic ultrasound systems and, in particular, to ultrasonic matrix array probes which dissipate heat generated by the probe ASIC through the probe cable.

[0002] Two dimensional array transducers are used in ultrasonic imaging to scan in three dimensions. Two dimensional arrays have numerous rows and columns of transducer elements in both the azimuth and elevation directions, which would require a large number of cable conductors to couple signals between the probe and the mainframe ultrasound system. A preferred technique for minimizing the number of signal conductors in the probe cable is to perform at least some of the beamforming in the probe in a microbeamformer ASIC (application specific integrated circuit.) This technique requires only a relatively few number of partially beamformed signals to be coupled to the mainframe ultrasound system, thereby reducing the required number of signal conductors in the cable. However a large number of signal connections must be made between the two dimensional array and the microbeamformer ASIC. An efficient way to make these connections is to design the transducer array and the ASIC to have flip-chip interconnections, whereby conductive pads of the transducer array are bump bonded directly to corresponding conductive pads of the ASIC.

[0003] The high density electronic circuitry of the microbeamformer ASIC can, however, produce a significant amount of heat in its small IC package, which must be dissipated. There are two main directions in which this heat can flow. One direction is forward through the acoustic stack toward the lens at the patient-contacting end of the probe. This forward path exhibits relatively low resistance to thermal flow. Build-up of heat in the lens must then be prevented by reducing transmission voltage and/or the pulse repetition frequency, which adversely affects probe performance.

[0004] The preferred thermal conduction direction is to the rear, away from the lens and patient and toward a heat spreader (typically aluminum) at the rear of the probe. But generally located behind the transducer stack, the array elements and the microbeamformer ASIC, is an acoustic backing block. The purpose of the acoustic backing block is to attenuate ultrasonic energy emanating from the rear of the acoustic stack and prevent this energy from causing reverberations that are reflected toward the acoustic stack. An acoustic backing block is generally made of a material with good acoustic attenuation properties such as an epoxy loaded with microballoons or other sound-deadening particles. Such materials, however, typically have poor thermal conductivity. Hence it is desirable to provide an acoustic backing block for an ultrasound probe which exhibits good acoustic attenuation of acoustic energy entering the block, good thermal conductivity toward the rear of the probe and away from the lens, good mechanical structure which can support the acoustic stack as needed, and appropriate electrical isolation of the microbeamformer ASIC from other conductive components of the probe.

[0005] An acoustic backing block which exhibits these characteristics is described in U.S. patent application Ser. No. 61/453690, filed Mar. 17, 2011. The backing block described in this patent application is formed of a matrix of a highly thermally conductive material with internal acoustic damping members. A preferred material for the thermally conductive material is graphite exhibiting a high thermal conductivity.

The graphite is formed into a rigid block with the mechanical stability to support a transducer array stack. The internal acoustic damping members, which can be formed by drilling holes in the graphite block which are filled with acoustic damping material, are preferably located such that an acoustic wave traveling normal to the rear surface of the transducer array stack must encounter an acoustic damping member and be acoustically attenuated.

[0006] While this thermally conductive backing block is an excellent conductor of heat away from the microbeamformer ASIC, there remains a problem in how and where to dissipate the heat. Without more, the heat must dissipate from the probe itself. Ultrasound transducers with no internal electronics can effectively dissipate heat from the transducer elements using modest thermal measures such as metal heat fins in the backing, the probe frame, and heat sinks in the probe. As integrated circuitry has begun to be located in the probe, passive cooling elements such as heat spreaders internal to and coupled to the probe housing have been used to dissipate the additional heat. See, e.g., U.S. patent application Ser. No. 61/486,796, filed May 17, 2011. However, even such improved passive cooling is unable to fully dissipate all the heat generated by the integrated circuitry, leading to compromises in performance such as those mentioned above to stay below thermal limits. What is needed is additional capacity to dissipate transducer heat. One further approach beyond the probe itself is to connect the thermal path in the probe to metal components in the cable (i.e., the signal/power conductors and the shield braid) to dissipate heat through these components. However, the present inventors have found that this does not significantly improve the heat dissipation capability because of limitations in the thermal conductivity along the cable in the conductors and braid, and the thermal conductivity from the conductors and braid to the cable surface, where the heat is dissipated. The present invention is directed to more effectively use the transducer cable to help dissipate this additional heat. This can help manage both lens face temperature and probe handle temperature.

[0007] In accordance with the principles of the present invention, an ultrasonic matrix array probe is described which dissipates heat generated by the probe microbeamformer ASIC through the probe cable by means of a fluid based closed loop active cooling system. A heat exchanger in the probe is in thermal communication with a thermally conductive backing block thermally coupled to the probe ASICs. In one embodiment the heat exchanger is embedded in the thermally conductive backing block. A fluid is pumped through fluid conduits in the cable and through the probe heat exchanger by a pump located in the probe case or the probe connector at the proximal end of the cable. The fluid conduits are formed and arranged in the cable in a manner which efficiently conducts heat from the fluid to the cable surface where it is dissipated by radiation and convection. Additional cooling can be provided by metal-to-metal contact between the probe connector and the ultrasound system which provides additional cooling capacity without a fluid connection between the ultrasound system and the closed loop system of the probe. The closed loop cooling system is completely contained within the probe, its cable, and probe connector.

[0008] In the drawings:

[0009] FIG. 1 illustrates a matrix array probe acoustic stack with a thermally conductive backing block constructed in accordance with the principles of the present invention.

[0010] FIG. 2 illustrates a matrix array probe, connector and thermally dissipating cable constructed in accordance with the principles of the present invention.

[0011] FIGS. 3, 4, 5 and 6 illustrate different bundling of transducer conductors and fluid conduits for probe heat dissipation in a probe cable in accordance with the principles of the present invention.

[0012] FIG. 7 illustrates a heat dissipating probe cable jacket with integrally formed fluid conduits in accordance with the principles of the present invention.

[0013] FIG. 8 is a perspective view of a thermally conductive backing block.

[0014] FIG. 9 illustrates a thermally conductive backing block with a fluid cooling channel in accordance with the principles of the present invention.

[0015] FIG. 10 illustrates a thermally conductive graphite foam backing block constructed in accordance with the principles of the present invention.

[0016] FIG. 11 illustrates an embodiment of the present invention in which heat is exchanged by metal-to-metal contact between a probe connector and a chiller in the mainframe ultrasound system.

[0017] Referring first to FIG. 1, an acoustic stack 100 with a thermally conductive backing block which is constructed in accordance with the principles of the present invention is shown schematically. A piezoelectric layer 110 such as PZT and two matching layers 120, 130 bonded to the piezoelectric layer are diced by dicing cuts 75 to form an array 170 of individual transducer elements 175, four of which are seen in FIG. 1. The transducer array 170 may comprise a single row of transducer elements (a 1-D array) or is a piezoelectric plate diced in two orthogonal directions to form a two-dimensional (2D) matrix array of transducer elements. The matrix array 170 may also comprise a one or two dimensional array of micromachined ultrasound transducer (MUTs) formed on a semiconductor substrate by semiconductor processing. The matching layers match the acoustic impedance of the piezoelectric material to that of the body being diagnosed, generally in steps of progressive matching layers. In this example the first matching layer 120 is formed as an electrically conductive graphite composite and the second matching layer 130 is formed of a polymer loaded with electrically conductive particles. A ground plane 180 is bonded to the top of the second matching layer, and is formed as a conductive layer on a film 150 of low density polyethylene (LDPE) 140. The ground plane is electrically coupled to the transducer elements through the electrically conductive matching layers and is connected to a ground conductor of flex circuit 185. The LDPE film 150 forms the third and final matching layer 140 of the stack.

[0018] Below the transducer elements is an integrated circuit 160, an ASIC, which provides transmit signals for the transducer elements 175 and receives and processes signals from the elements. Conductive pads on the upper surface of the integrated circuit 160 are electrically coupled to conductive pads on the bottoms of the transducer elements by stud bumps 190, which may be formed of solder or conductive epoxy. Signals are provided to and from the integrated circuit 160 by connections to the flex circuit 185. Below the integrated circuit 160 is a backing block 165 which attenuates acoustic energy emanating from the bottom of the transducer stack. In accordance with the principles of the present invention, the backing block also conducts heat generated by the

integrated circuit away from the integrated circuit and the transducer stack and away from the patient-contacting end of the transducer probe.

[0019] FIG. 2 illustrates a matrix array transducer probe 14, cable 28 and connector 32 constructed in accordance with the principles of the present invention. The probe components are housed in an external polymeric case 20. A strain relief sleeve 18 surrounds the cable 28 where it enters the probe case 20. A structure 12 inside the case called a "spaceframe" supports the internal components of the probe and fits to the internal dimensions of the case. At the distal, patient-contacting end of the probe is the matrix array acoustic stack 100. The non-conductive patient-contacting surface of the probe through which ultrasound waves are sent and received is referred to as a lens 10. Behind the two dimensional transducer array 170 are the beamformer ASICs 160 and behind the ASICs and in thermal contact with them is the acoustically attenuating and thermally conductive backing block 165. In accordance with the present invention, a heat exchanger 16 is in thermal contact with the back of the thermally conductive backing block 165. Cooling fluid is pumped into an inlet port of the heat exchanger through a first conduit 22 and warmed fluid carrying heat from the probe flows out of the probe through a second conduit 24. These conduits pass through the probe cable 28 along with the signal and power conductors for the probe 14. The heat conveyed by the fluid in the second conduit 24 dissipates through the external covering of the cable as described more fully below. The fluid in this closed loop system is continuously circulated by a pump 26 which is coupled to the two fluid conduits 22 and 24. The pump is located in the probe connector 32 which connects the probe and its cable to a mainframe ultrasound system. An electrical socket 34 in the connector mates with a plug on the ultrasound system when the connector 32 is attached to the ultrasound system. In this arrangement a cooling fluid is pumped through the cable conduit 22 and through the heat exchanger 16, where it picks up heat from the ASICs 160 which has been conducted away from the ASICs by the thermally conductive backing block. The warmed fluid exits the probe 14 through the conduit 24 and passes through the cable 28, where it dissipates heat by convection and conduction through the surface of the cable. Since probe cables are quite long, there is a considerable length of cable and cable surface area from which to dissipate the heat picked up in the probe. The flowing fluid returns in a cooled state to the pump 26 and the process continues.

[0020] FIGS. 3-6 illustrate a number of techniques for configuring a fluid-based, thermally dissipating probe cable 28 for efficient and effective heat transfer and dissipation from the warmed fluid. In the implementation of FIG. 3 the out-bound (from the probe; heated) conduit 24 is located on one side of the cable and the inbound (cool) conduit 22 is located on the other side of the cable, separated by the signal and power electrical conductors running from the connector 32 to the probe 14. In this implementation the electrical conductors are bundled into discrete sub-bundles 40. By keeping the electrical conductors into sub-bundles the conductor sub-bundles will stay in place around and between the fluid conduits and will not separate individually and be displaced as can happen with individual unbundled conductors. The sub-bundles of electrical conductors will thus keep the fluid conduits separated from each other thermally on opposite sides of the cable. The sub-bundles and conduits are surrounded by a metallic and/or graphite cable braid 42 which provides an r.f.

electrical shield for the electrical conductors and also runs the length of the cable. The cable braid also provides efficient heat transfer from the outbound (warm) conduit **24** to the outer cable jacket. Heat from the fluid in the outbound conduit **24** is then dissipated from the surface **44** of the cable jacket. [0021] FIG. 4 illustrates another cable configuration in which the inbound (cool) conduit **22** is located in the cable braid **42** with the electrical conductor sub-bundles **40**. The other conduit **24** is located outside the cable braid **42**. The cable braid shields the conductors as in the previous example, and the sub-bundles again separate the two conduits. Alternatively the conduits can be reverse-packaged, with the outbound conduit **24** inside the cable braid **42** and the inbound conduit **22** located outside the braid. The electrical conductors, braid and conduits are again located in the cable jacket **44**.

[0022] The implementation of FIG. 5 is similar to that of FIG. 3, with the addition of a thermally conductive layer **46** between the cable braid **42** and the outer surface **44** of the cable jacket. The thermally conductive layer, which may be a part of the jacket, facilitates efficient heat transfer from the outbound (warm) conduit **24** to the surface of the cable **28**.

[0023] FIG. 6 illustrates another approach to separating the two fluid conduits, which is the use of helically wound tubes **22'**, **24'** for the two conduits. The turns of the two helical windings are in interleaved alternation so that the two fluid conduits are always separated. The electrical conductors run through the center of the two helical tubes and the cable jacket **44** encases the helical conduits and conductors. A helically wound conduit presents a greater surface area to the cable jacket than does a straight conduit, affording greater heat transfer from the warmed fluid inside the conduit and cable.

[0024] In the implementation of FIG. 7 the fluid conduits **22**, **24** are formed integral with the cable jacket **44**. The fluid conduits **22**, **24** are thus formed during the extrusion of the cable jacket. The two fluid conduits will stay separated because they are integrally attached to opposite sides of the jacket, with the shielded electrical conductors running through the center of the jacket.

[0025] There are several ways to implement effective heat exchange between the thermally conductive backing block **165** and the heat exchanger **16** in the probe. One is to form the heat exchanger **16** as part of the spaceframe of the probe. The spaceframe is generally made of aluminum, which is an efficient conductor of heat. The heat exchanger **16** in FIG. 2 is then a cross-member of the spaceframe which mounts the acoustic stack and its thermally conductive backing block, with the backing block in thermal communication with the cross-member **16**. A number of fluid channels are machined through the cross-member **16** and coupled to the fluid conduits so that incoming fluid from conduit **22** flows through the channels and out through the outbound conduit **24**. As the cross-member **16** is heated by heat transferred to it by the backing block, that heat is carried away by the fluid flowing through the channels of the cross-member.

[0026] Another heat exchange implementation in the probe is to include a Peltier device in the heat exchanger **16**, in thermal communication with the thermally conductive backing block **165**. A Peltier device has a metal-to-metal junction of two types of metal. When an electrical current is applied to the junction, one side gets cool and the other side gets warm. With the cool side in thermal contact with the backing block, the Peltier device will then draw heat out of the backing block. A fluid tube, coil, or channel member of a heat exchanger as

previously described, through which fluid of the fluid conduits **22**, **24** flows, is in thermal communication with the warm side of the Peltier device and conducts and carries away heat from the warm side of the device through the fluid of the outbound conduit **24**.

[0027] A third probe heat exchange implementation is shown in FIGS. 8, 9, and 10. In this implementation fluid heat exchange is done within the thermally conductive backing block. FIG. 8 illustrates a thermally conductive and acoustically attenuating graphite backing block as described in aforementioned U.S. patent application Ser. No. 61/453690, filed Mar. 17, 2011. In this illustration the graphite is rendered translucent for clarity of illustration of the internal composite structure of the block. The acoustic dampening members are formed as a plurality of angled cylinders **30** of backing material in the backing block. The cylinders **30** are cut or drilled into the graphite block **20**, then filled with acoustic dampening material such as epoxy filled with micro balloons or other acoustic damping particles. The tops of the cylinders **30** present a large area of acoustic dampening material to the back of the integrated circuit **160**. A considerable amount of the undesired acoustic energy emanating from the back of the integrated circuit and acoustic stack will thus pass immediately into the dampening material. The angling of the cylinders as seen in FIG. 8 and the cross-sectional view of FIG. 9 assures that acoustic energy traveling in the Z-axis direction away from the ASIC will have to intersect dampening material at some point in the path of travel. Preferably, there is no path in the Z-axis direction formed entirely of graphite, and the angling of the cylinders does not promote reflection of energy back to the integrated circuit but provides scattering angles downward and away from the integrated circuit. In practice it may be sufficient to block most of the Z-axis pathways such as by blocking 95% of the pathways. Thus, the angling of the cylinders assures damping of all or substantially all of the Z-axis directed acoustic energy.

[0028] Heat, however, will find continuous pathways through the graphite between the cylinders **30**. Since the flow of heat is from higher temperature regions to lower (greater thermal density to lesser), heat will flow away from the integrated circuit **160** and acoustic stack **100** to structures below the backing block **165** where it may be safely dissipated.

[0029] For fluid-based closed loop cooling a fluid channel **54** is formed in the backing block **165** as shown in the cross-sectional view of FIG. 9. The inbound (cooling) conduit **22** is coupled to the inlet port **52** of the fluid channel **54** and the outbound (warm) conduit **24** is coupled to the outlet port **56** of the fluid channel. As heat is transferred into the backing block **165** from ASIC **160**, it is carried away from the backing block and probe by the fluid flow through the outbound fluid conduit **24**. Heat exchange is done within the backing block itself with no separate heat exchanger.

[0030] Another implementation of this technique is shown in FIG. 10. In this implementation the thermally conductive and acoustically attenuating backing block **165** is formed of highly porous graphite foam **36**. A coating of epoxy resin **38** on the outer surface of the graphite foam block provides structural rigidity and an epoxy surface that readily bonds to the ASIC **160**. Holes are drilled through the epoxy layer on either side of the block and fluid ports **52** and **56** are located in the holes. The fluid ports thus access the highly porous interior of the block **165**. The open structure of the porous graphite foam allows fluid to flow from one port to the other. Cool fluid flows in one port from the inbound conduit **22**, through

the porous foam structure, and out through the other port and into the outbound conduit **24**. The graphite **36** efficiently conducts heat into the block **165** to be carried away by the fluid flow, the open foam structure promotes the fluid flow, and the graphite particles effectively scatter and attenuate acoustic energy from the back of the acoustic stack.

[0031] If even greater heat dissipation is required than that afforded through the cable **28**, additional cooling can be provided from the ultrasound system. Preferably, this additional cooling is provided without any fluid communication between the connector and the ultrasound system; it is desirable to keep the closed loop fluid flow completely within the probe, cable and connector. In FIG. **11** a metal plate **60** with fluid channels passing therethrough is located in the connector with the electrical socket **34**. The outbound (warm) fluid conduit is coupled to one end of the fluid channels of plate **60**, and a fluid conduit **23** is coupled from the other end of the fluid channels to the pump **26**. Warm fluid will thus flow through the plate **60**, heating the plate, before being pumped back to the cable and probe. When the probe connector **32** is plugged into the ultrasound system **200** and the electrical socket mates with the matching plug **34'** of the ultrasound system, the plate **60** is pressed into contact against another fluid channel plate **62** of the ultrasound system. The plate **62** is cooled by apparatus in the ultrasound system. Since space and power is not at a premium in the ultrasound system as it is in the probe, a cooling system of almost any design can be used in the ultrasound system. A preferred cooling system is a chiller/evaporator **68**, located in and powered by the ultrasound system, which pumps chilled fluid through fluid conduits **64**, **66** and fluid channels of the plate **62**. The plate **62** is thereby chilled to a considerably low temperature relative to ambient temperature. The metal to metal contact of chilled plate **62** and connector plate **60** which is warmed by fluid from the probe effects a rapid and efficient transfer of heat from the fluid in the warmed plate **60** to the chilled plate **62**. The thermal communication between the two plates is established when the probe connector is plugged into the ultrasound system, and no fluid passes between the probe components and the ultrasound system.

[0032] Variations of the systems described above will readily occur to those skilled in the art. A heat exchanger need not be made of metal elements, but can use other conductive elements such as graphite, silicon, or other conductive materials. Obstruction of the fluid conduits due to bending, kinking, or twisting of the cable can be minimized by using redundant conduits, such as two inbound conduits alternated with two outbound conduits and located every 90° around the cable. Flow monitoring can be employed to assure the continued operation of the cooling system through the use of flow sensors, pressure sensors, or temperature monitoring. A fluid reservoir can be connected to the fluid loop to provide for expansion and contraction of the fluid due to temperature and pressure changes.

1. An ultrasonic transducer probe assembly comprising:
 - a probe case;
 - an array of transducer elements located behind an acoustic window in the probe case and configured to transmit and receive ultrasound energy through the acoustic window;
 - an integrated circuit coupled to the transducer elements in the probe case and configured to process signals transmitted or received by the array;
 - a probe connector configured to connect the transducer probe to an ultrasound system;

a cable connected between the probe case and the probe connector; and

a fluid-based closed loop cooling system comprising:

- a closed fluid loop extending through the cable from the probe case to the probe connector;
- a pump, coupled to the fluid loop, which pumps fluid through the loop; and
- a heat exchanger located in the probe case which acquires heat from the transducer array and integrated circuit, wherein the closed fluid loop in the cable comprises an inbound fluid conduit and an outbound fluid conduit that are helically wound and separated from each other within the cable by bundles of electrical conductors coupled between the probe case and the probe connector.

2. The ultrasonic transducer probe assembly of claim 1, wherein the inbound and outbound fluid conduits and the bundles of electrical conductors are surrounded by a cable braid.

3. The ultrasonic transducer probe assembly of claim 2, wherein the cable braid is located against an inner wall of a cable jacket of the cable.

4. The ultrasonic transducer probe assembly of claim 3, wherein the cable braid further comprises a metallic or graphite cable braid.

5. The ultrasonic transducer probe assembly of claim 1, further comprising a cable braid located within the cable, wherein the cable braid encloses the inbound fluid conduit and the bundles of electrical conductors, wherein the outbound fluid conduit is located outside the cable braid and adjacent an inner wall of a cable jacket of the cable.

6. The ultrasonic transducer probe assembly of claim 1, further comprising a cable braid located within the cable, wherein the cable braid encloses the outbound fluid conduit and the bundles of electrical conductors, wherein the inbound fluid conduit is located outside the cable braid.

7. The ultrasonic transducer probe assembly of claim 6, wherein the outbound fluid conduit in the cable braid is positioned adjacent an inner wall of a cable jacket of the cable.

8. The ultrasonic transducer probe assembly of claim 1, wherein a cable jacket of the cable further comprises an inner wall and an exterior wall,

wherein the inner wall of the cable jacket is lined with a material exhibiting high thermal conductivity to promote the transfer of heat from an interior of the cable to the exterior wall of the cable jacket.

9. The ultrasonic transducer probe assembly of claim 1, wherein a cable jacket of the cable further comprises a material exhibiting high thermal conductivity to promote the transfer of heat from an interior of the cable to the exterior wall of the cable jacket.

10. An ultrasonic transducer probe assembly comprising:

- a probe case;
- an array of transducer elements located behind an acoustic window in the probe case and configured to transmit and receive ultrasound energy through the acoustic window;
- an integrated circuit coupled to the transducer elements in the probe case and configured to process signals transmitted or received by the array;
- a probe connector configured to connect the transducer probe to an ultrasound system;
- a cable connected between the probe case and the probe connector comprising an outer cable jacket; and

a fluid-based closed loop cooling system comprising:
 a closed fluid loop extending through the cable from the probe case to the probe connector;
 a pump, located in the probe connector, which pumps fluid through the loop; and
 a heat exchanger located in the probe case which acquires heat from the transducer array and integrated circuit, wherein the closed fluid loop in the cable comprises an inbound fluid conduit and an outbound fluid conduit that are helically wound and separated from each other within the cable by electrical conductors coupled between the probe case and the probe connector.

11. The ultrasonic transducer probe assembly of claim **10**, wherein the inbound and outbound fluid conduits are part of the outer cable jacket.

12. The ultrasonic transducer probe assembly of claim **11**, wherein the inbound and outbound fluid conduits are on opposite sides of the outer cable jacket.

13. The ultrasonic transducer probe assembly of claim **10**, wherein the outer cable jacket further comprises an inner surface and an exterior surface,
 wherein the inbound and outbound fluid conduits are attached to the inner surface of the cable jacket.

14. An ultrasonic transducer probe assembly comprising:
 a probe case;
 an array of transducer elements located behind an acoustic window in the probe case and configured to transmit and receive ultrasound energy through the acoustic window;

an integrated circuit coupled to the transducer elements in the probe case and configured to process signals transmitted or received by the array;

a probe connector configured to connect the transducer probe to an ultrasound system;

a cable connected between the probe case and the probe connector comprising an outer cable jacket; and

a fluid-based closed loop cooling system comprising:

a closed fluid loop extending through the cable from the probe case to the probe connector;

a pump, coupled to the fluid loop, which pumps fluid through the loop; and

a heat exchanger located in the probe case which acquires heat from the transducer array and integrated circuit,

wherein the closed fluid loop in the cable comprises an inbound fluid conduit and an outbound fluid conduit helically wound and separated from each other within the cable and having a common central passageway through which extend electrical conductors coupled between the probe case and the probe connector.

15. The ultrasonic transducer array assembly of claim **14**, wherein the inbound fluid conduit and the outbound fluid conduit are alternately helically wound within the cable so as to be separated from each other within the cable.

* * * * *

专利名称(译)	带散热电缆的超声矩阵阵列探头		
公开(公告)号	US20150045670A1	公开(公告)日	2015-02-12
申请号	US14/386035	申请日	2013-03-12
[标]申请(专利权)人(译)	皇家飞利浦电子股份有限公司		
申请(专利权)人(译)	皇家飞利浦N.V.		
当前申请(专利权)人(译)	皇家飞利浦N.V.		
[标]发明人	DAVIDSON RICHARD EDWARD SCARSELA MICHAEL TAYLOR JAMES CHRISTOPHER ROBINSON ANDREW LEE		
发明人	DAVIDSON, RICHARD EDWARD SCARSELA, MICHAEL TAYLOR, JAMES CHRISTOPHER ROBINSON, ANDREW LEE		
IPC分类号	A61B8/00		
CPC分类号	A61B8/4494 A61B8/4444 A61B8/4488 A61B8/546 A61B2018/00023 G01S7/52079 G10K11/004		
优先权	61/613071 2012-03-20 US		
其他公开文献	US9867592		
外部链接	Espacenet USPTO		

摘要(译)

包括换能器阵列和耦合到换能器元件的集成电路的矩阵阵列探针通过换能器探头的盖子消散由阵列和集成电路产生的热量。探头连接器中的泵将流体泵送通过闭环系统，该系统包括电缆中的入站流体导管。电缆中的流体导管由用于探针的电缆电导体分开。探头中的热传递通过探头空间框架或换能器堆叠背衬块中的热交换器完成，并且可以使用珀耳帖装置。可以通过金属对金属与超声系统中的冷却器接触来提供额外的冷却。

