



US009050052B2

(12) **United States Patent**
Irie

(10) **Patent No.:** **US 9,050,052 B2**
(45) **Date of Patent:** **Jun. 9, 2015**

(54) **ULTRASOUND ENDOSCOPE**

(56) **References Cited**

(71) Applicant: **OLYMPUS MEDICAL SYSTEMS CORP.**, Tokyo (JP)

U.S. PATENT DOCUMENTS

(72) Inventor: **Kei Irie**, Akiruno (JP)

4,605,009 A	8/1986	Pourcelot et al.	
5,467,779 A *	11/1995	Smith et al.	600/445
2006/0058676 A1	3/2006	Yagi et al.	
2008/0084137 A1	4/2008	Wakabayashi et al.	
2009/0093725 A1	4/2009	Sato et al.	
2011/0166455 A1	7/2011	Cully et al.	

(73) Assignee: **OLYMPUS MEDICAL SYSTEMS CORP.**, Tokyo (JP)

FOREIGN PATENT DOCUMENTS

(*) Notice: Subject to any disclaimer, the term of this patent is extended or adjusted under 35 U.S.C. 154(b) by 0 days.

JP	01-291846 A	11/1989
JP	H02-271843 A	11/1990
JP	05-015536 A	1/1993
JP	H06-335481 A	12/1994
JP	2003-033354 A	2/2003
JP	2004-209044 A	7/2004
JP	2005-218519 A	8/2005
WO	WO 03/086196 A1	10/2003

(21) Appl. No.: **13/965,414**

(22) Filed: **Aug. 13, 2013**

(65) **Prior Publication Data**

US 2014/0058269 A1 Feb. 27, 2014

OTHER PUBLICATIONS

Extended Supplementary European Search Report dated Mar. 16, 2015 from related European Application No. 13 79 5683.5.

Related U.S. Application Data

(63) Continuation of application No. PCT/JP2013/063807, filed on May 17, 2013.

* cited by examiner

Primary Examiner — Unsu Jung

Assistant Examiner — Michael N Fisher

(30) **Foreign Application Priority Data**

Aug. 27, 2012 (JP) 2012-186871

(74) *Attorney, Agent, or Firm* — Scully, Scott, Murphy & Presser, P.C.

(51) **Int. Cl.**

A61B 8/14 (2006.01)

A61B 8/00 (2006.01)

A61B 8/12 (2006.01)

(52) **U.S. Cl.**

CPC **A61B 8/4444** (2013.01); **A61B 8/12** (2013.01); **A61B 8/445** (2013.01)

(58) **Field of Classification Search**

None

See application file for complete search history.

(57) **ABSTRACT**

A wiring board electrically connected to a back side of an ultrasound transmitting/receiving section that transmits/receives ultrasound includes a rigid circuit board included in a stiff portion, and a wrapping portion extending out from the rigid circuit board (stiff portion), and a plurality of drive wirings electrically connected to the wiring board are inserted into a wiring insertion portion of a housing with the plurality of drive wirings wrapped and bundled by the wrapping portion.

8 Claims, 12 Drawing Sheets

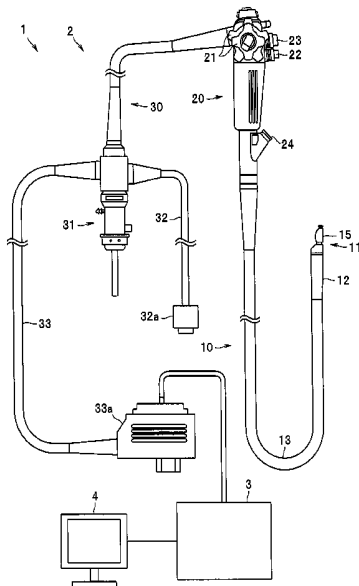

FIG. 1

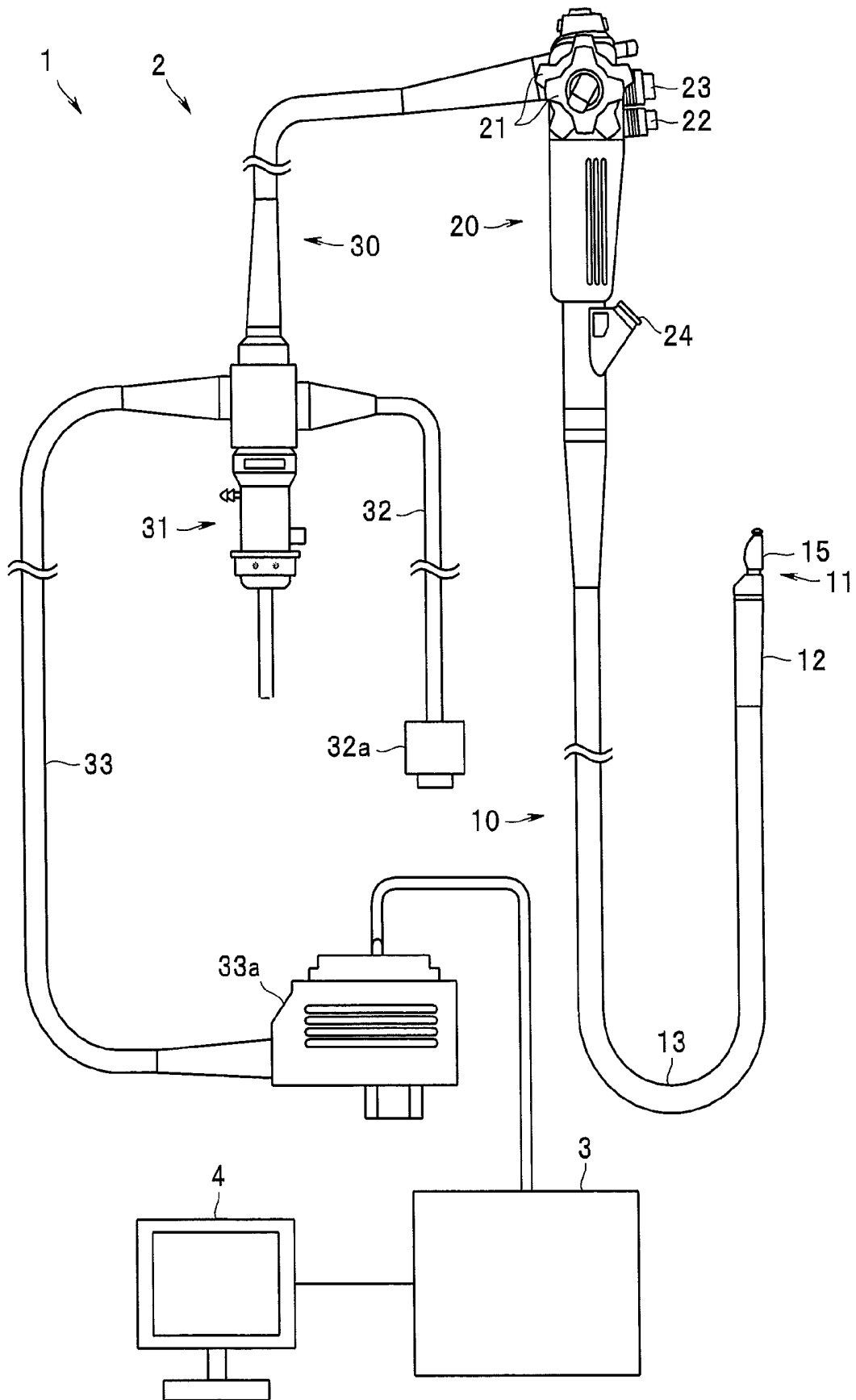

FIG. 2

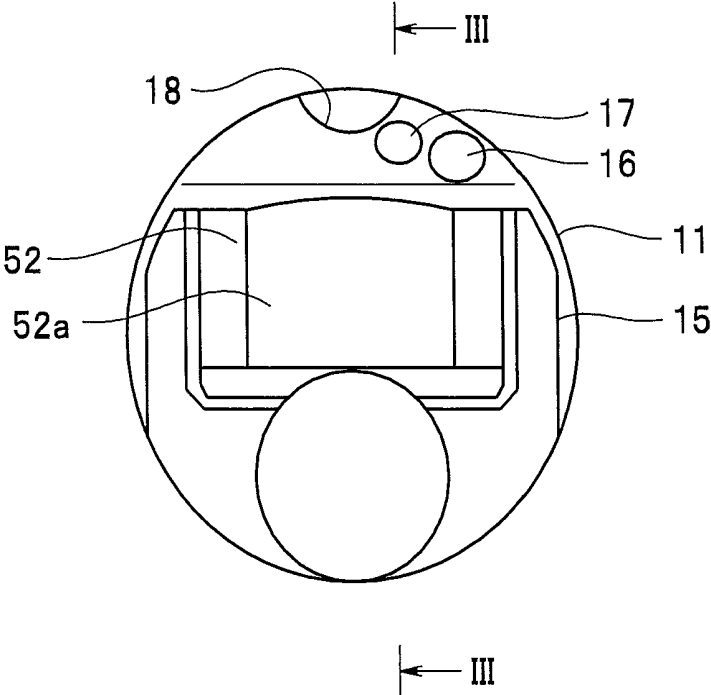

FIG. 3

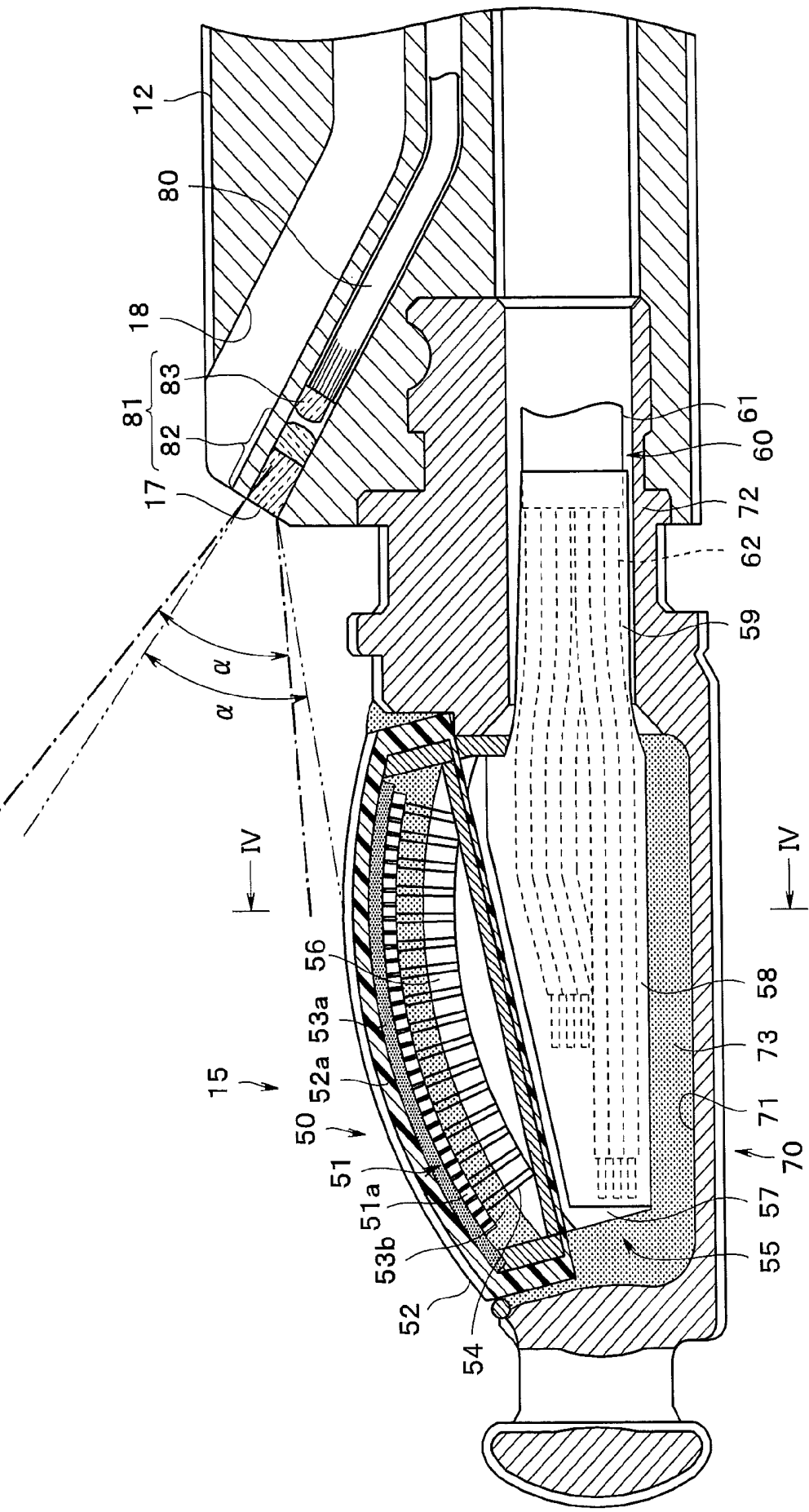

FIG. 4

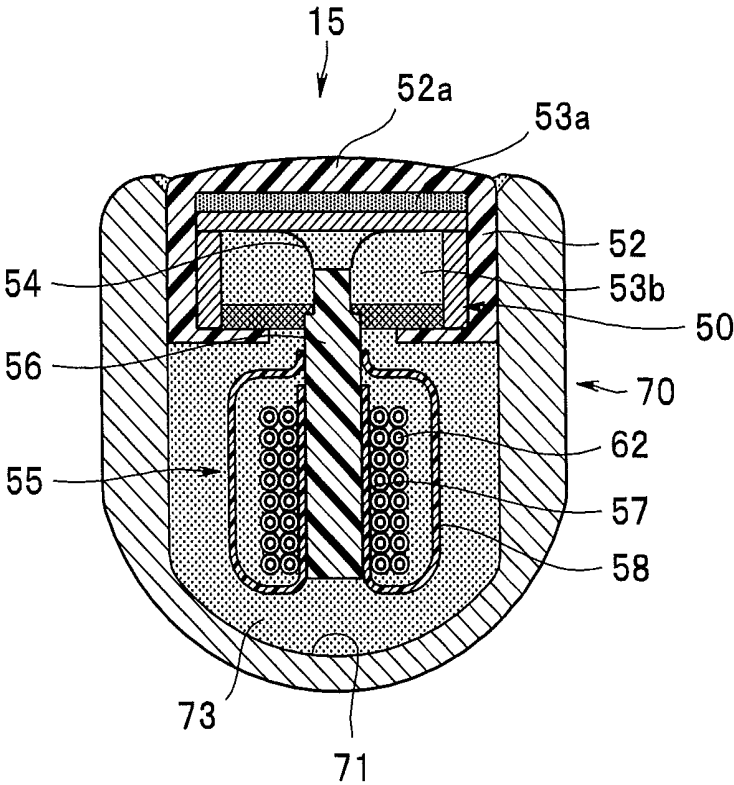

FIG. 6

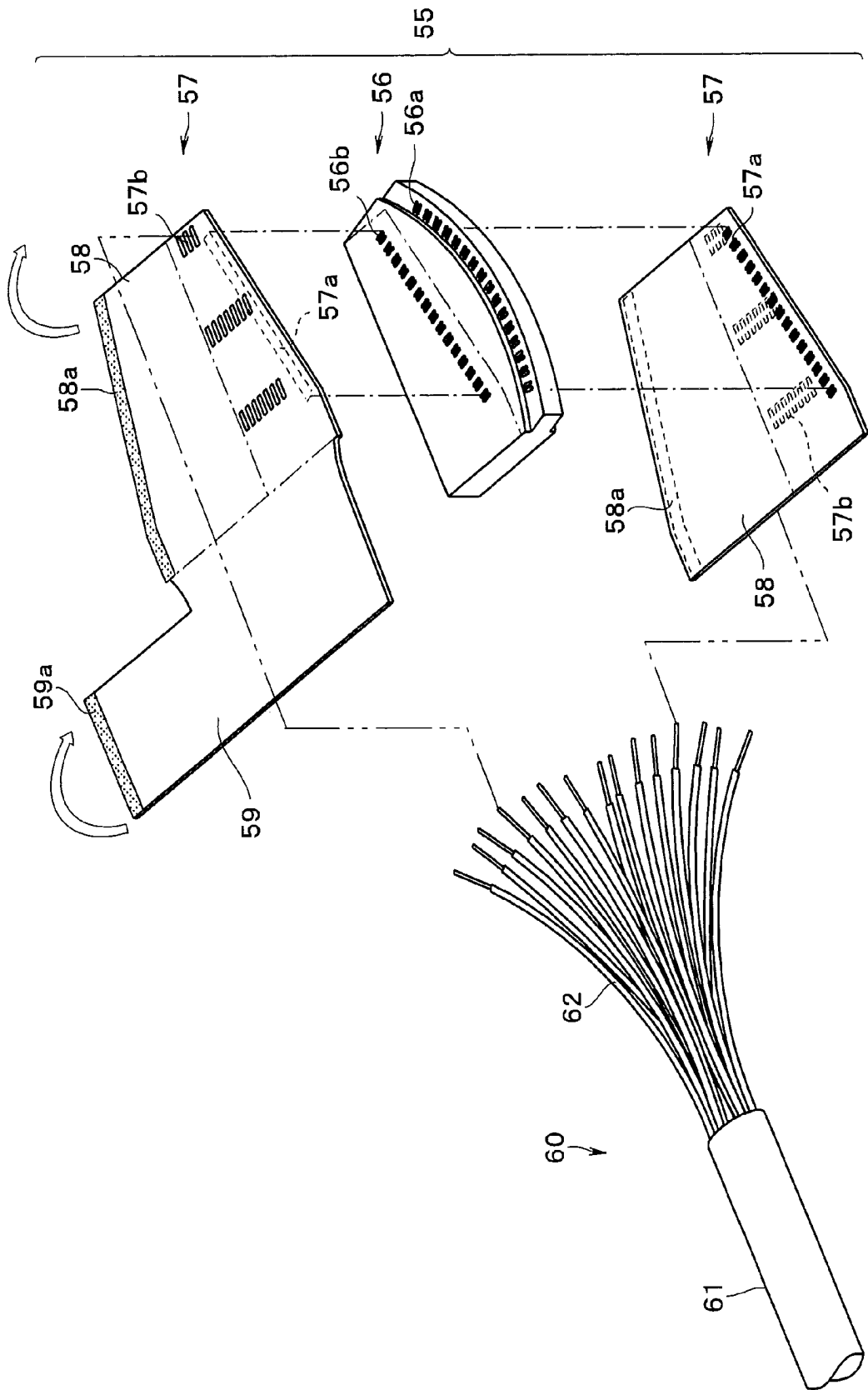

FIG. 7

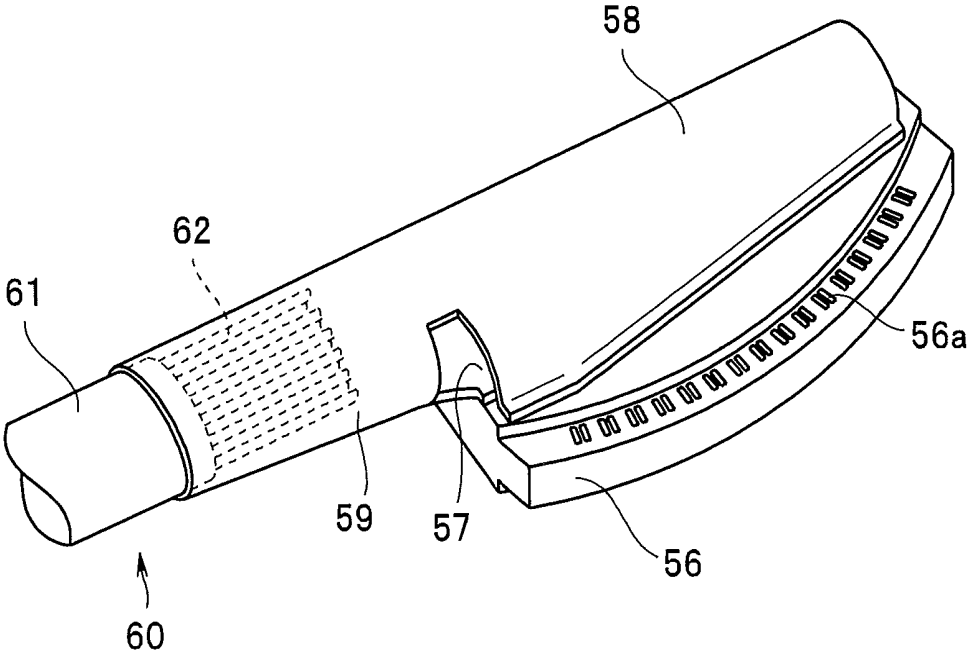

FIG. 8

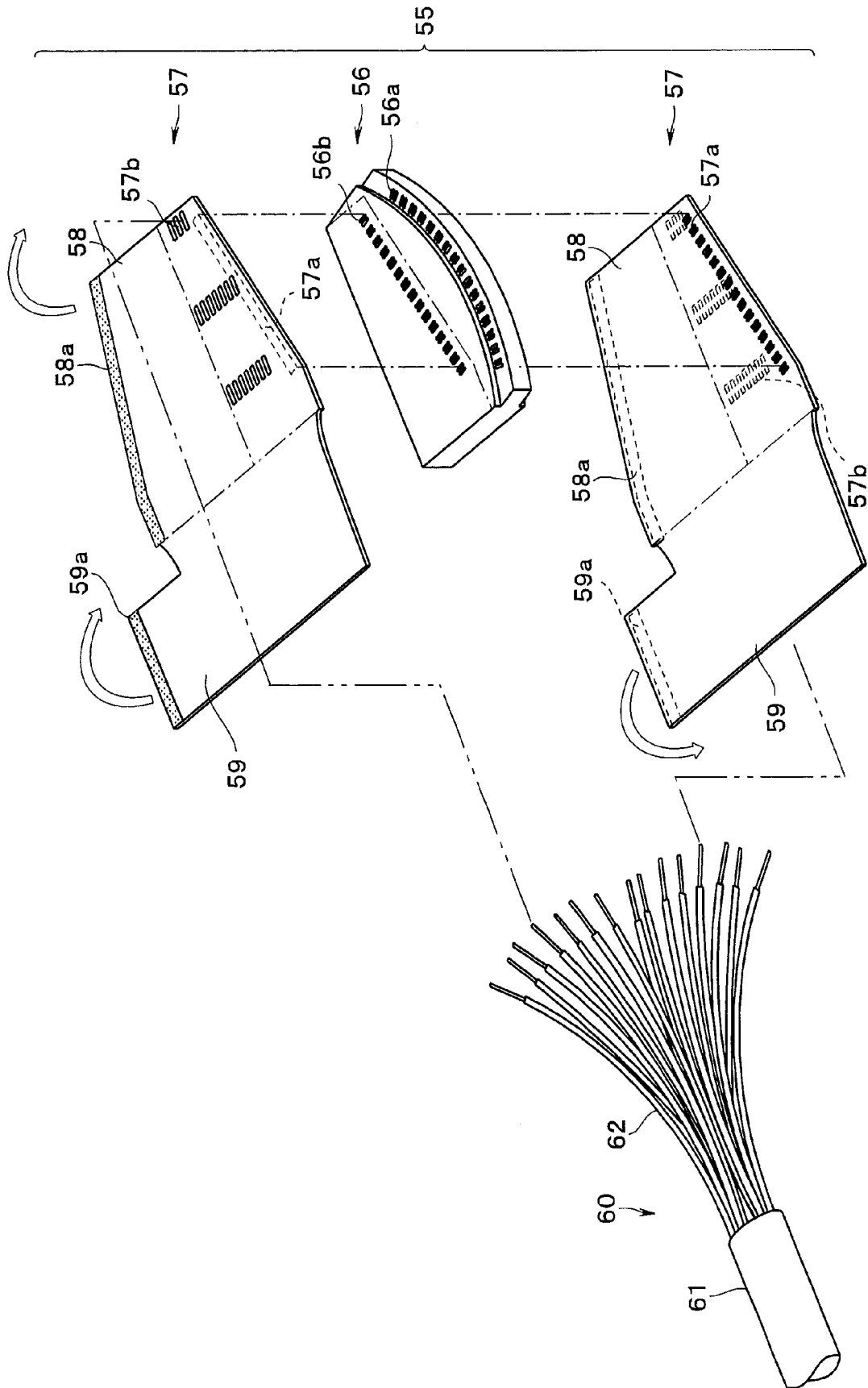

FIG. 9

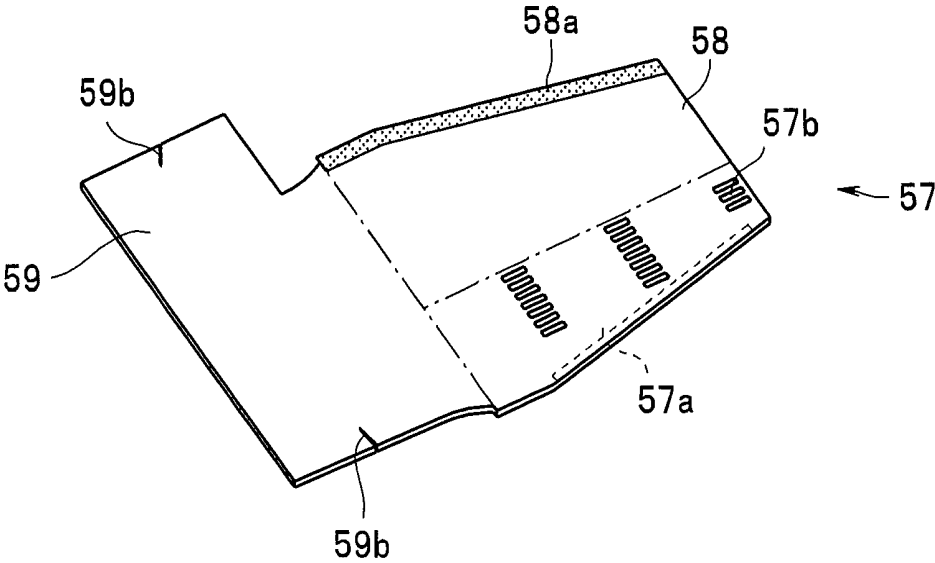

FIG. 10

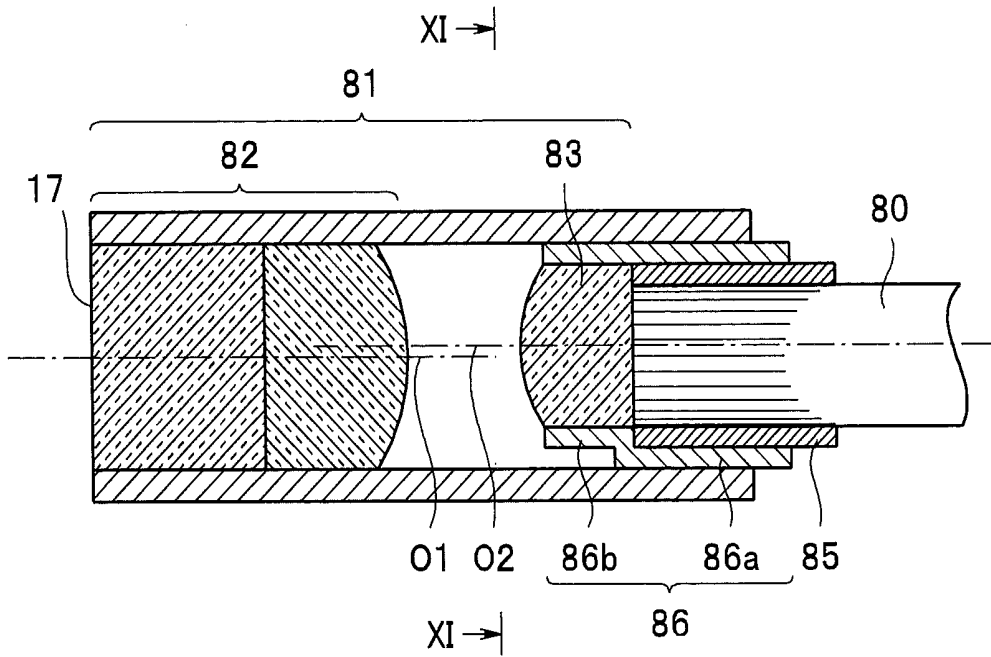

FIG. 11

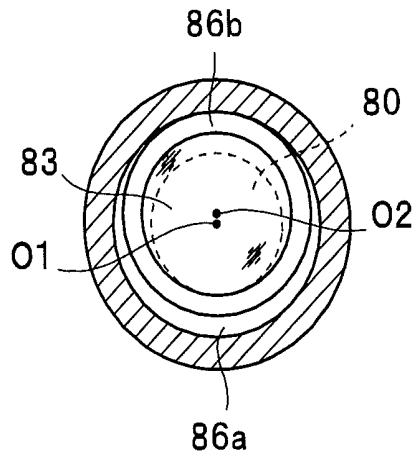

FIG. 14

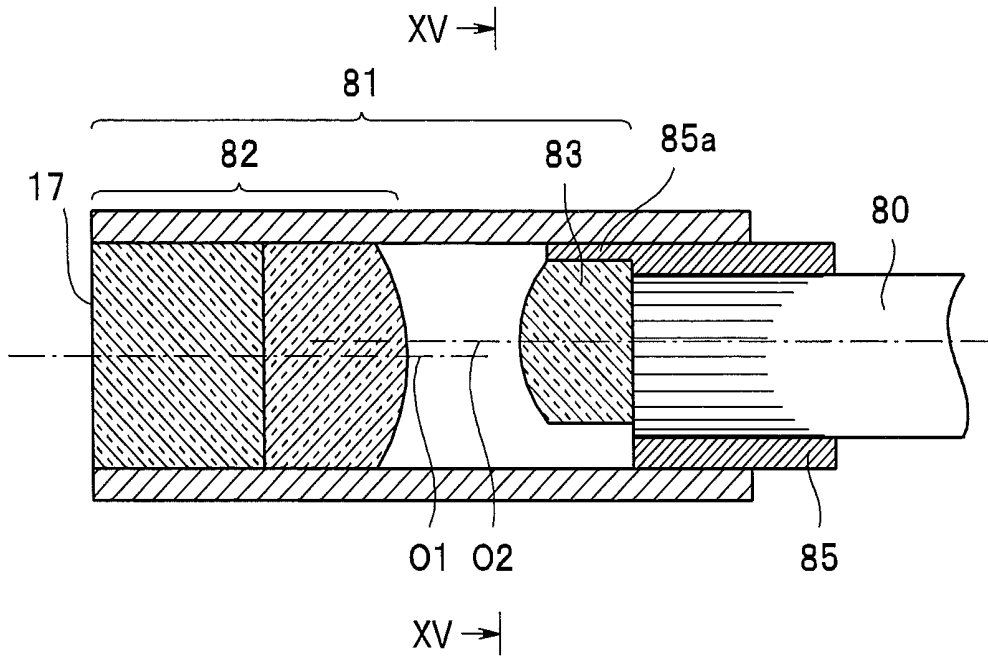
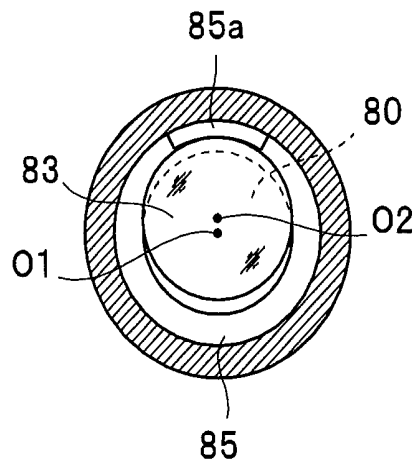

FIG. 15



ULTRASOUND ENDOSCOPE

CROSS REFERENCE TO RELATED APPLICATION

This application is a continuation application of PCT/JP2013/063807 filed on May 17, 2013 and claims benefit of Japanese Application No. 2012-186871 filed in Japan on Aug. 27, 2012, the entire contents of which are incorporated herein by this reference.

BACKGROUND OF THE INVENTION

1. Field of the Invention

The present invention relates to an ultrasound endoscope with a transducer unit housed in a housing provided in a distal end portion of an insertion portion.

2. Description of the Related Art

Conventionally, in, e.g., medical fields, ultrasound endoscopes including an ultrasound probe at a distal end of an elongated insertion portion of an endoscope have widely been used. Each such ultrasound endoscope forms an ultrasound endoscope system jointly with, for example, an ultrasound observation apparatus and a monitor. The ultrasound endoscope system, for example, transmits ultrasound from an ultrasound probe to a subject and processes a received ultrasound echo signal in the ultrasound observation apparatus, enabling provision of an ultrasound tomographic image of an inside of the subject.

The ultrasound probe used in each such ultrasound endoscope includes, for example, a transducer unit resulting from unitization of a plurality of ultrasound transducers together with an acoustic matching layer and a back-side damping layer, and the transducer unit is housed in a housing portion formed in a housing, whereby a main part of the ultrasound probe is formed. Here, in the transducer unit, a wiring board electrically connected to the respective ultrasound transducers is provided, and a plurality of drive wirings separately extending from the cable unit so as to correspond to the respective ultrasound transducers are electrically connected to respective terminals on the wiring board, respectively. Also, in order to route the cable unit inside the insertion portion of the endoscope, a tubular wiring insertion portion (pipe portion) is provided so as to connect to the housing portion of the transducer unit formed in the housing (see, for example, Japanese Patent Application Laid-Open Publication No. 2004-209044). When such ultrasound probe is assembled, first, the work of inserting the proximal end side of the cable unit into the wiring insertion portion from the housing portion side and then pushing the group of drive wirings forking from a distal end portion of the cable unit into the wiring insertion portion and the work of housing the transducer unit in the housing portion of the housing are performed.

In such type of ultrasound endoscopes, there is a strong demand for downsizing of ultrasound probes, and examples of measures to respond to such demands may include reduction in distance from the transducer unit to a mouth of the wiring insertion portion and reduction in diameter of the wiring insertion portion.

SUMMARY OF THE INVENTION

An ultrasound endoscope according to an aspect of the present invention includes: an ultrasound transmitting/receiving section that transmits/receives ultrasound; at least one wiring board electrically connected to a back side of the

ultrasound transmitting/receiving section; a plurality of drive wirings electrically connected to the wiring board; and a housing that houses the wiring board and holds the ultrasound transmitting/receiving section, wherein the housing includes a housing portion that houses the wiring board, and a tubular wiring insertion portion having a diameter smaller than the housing portion, the wiring insertion portion connecting to the housing portion; and wherein the wiring board includes a stiff portion electrically connected to the back side of the ultrasound transmitting/receiving section, a wrapping portion extending out from the stiff portion, the wrapping portion wrapping and bundling the plurality of the drive wirings and being inserted into the wiring insertion portion, and a protection sheet that extends out from the stiff portion and covers a portion of connection with the plurality of drive wirings.

BRIEF DESCRIPTION OF THE DRAWINGS

FIG. 1 is a diagram of a schematic configuration of an ultrasound endoscope;

FIG. 2 is a diagram of an end face of a distal end rigid portion;

FIG. 3 is a cross-sectional view along line III-III in FIG. 2;

FIG. 4 is a cross-sectional view along line IV-IV in FIG. 3;

FIG. 5 is an exploded side view illustrating a transducer unit to which a cable unit is connected, and a housing;

FIG. 6 is an exploded perspective view illustrating a wiring board and a cable unit;

FIG. 7 is a perspective view of a wiring board to which a cable unit is connected;

FIG. 8 is an exploded perspective view illustrating a modification of the wiring board and the cable unit;

FIG. 9 is a perspective view illustrating a modification of a flexible sheet;

FIG. 10 is a cross-sectional view of a main part of an observation optical lens system;

FIG. 11 is a cross-sectional view along line XI-XI in FIG. 10;

FIG. 12 is a cross-sectional view of a main part, which illustrates a modification of the observation optical lens system;

FIG. 13 is a cross-sectional view along line XIII-XIII in FIG. 12;

FIG. 14 is a cross-sectional view of a main part, which illustrates a modification of the observation optical lens system; and

FIG. 15 is a cross-sectional view along XV-XV in line FIG. 14.

DETAILED DESCRIPTION OF THE PREFERRED EMBODIMENT

An embodiment of the present invention will be described below with reference to the drawings. The drawings relate to the embodiment of the present invention: FIG. 1 is a diagram of a schematic configuration of an ultrasound endoscope; FIG. 2 is a diagram of an end face of a distal end rigid portion; FIG. 3 is a cross-sectional view along line III-III in FIG. 2; FIG. 4 is a cross-sectional view along line IV-IV in FIG. 3; FIG. 5 is an exploded side view illustrating a transducer unit to which a cable unit is connected, and a housing; FIG. 6 is an exploded perspective view illustrating a wiring board and a cable unit; FIG. 7 is a perspective view of a wiring board to which a cable unit is connected; FIG. 8 is an exploded perspective view illustrating a modification of the wiring board and the cable unit; and FIG. 9 is a perspective view illustrating a modification of a flexible sheet.

An ultrasound endoscope system **1**, which is illustrated in FIG. **1**, includes an ultrasound endoscope **2**, an ultrasound observation apparatus **3** and a monitor **4**. Also, the ultrasound endoscope **2** includes an elongated insertion portion **10** to be inserted into a body, an operation section **20** provided so as to be continuous with a proximal end of the insertion portion **10**, and a universal cord **30** extending from a side portion of the operation section **20**.

Here, a connector **31** connected to a light source apparatus (not illustrated) is provided at a proximal end portion of the universal cord **30**. A cable **32** connected to a camera control unit (not illustrated) via a connector **32a** and a cable **33** detachably connected to the ultrasound observation apparatus **3** via a connector **33a** extend out from the connector **31**. The ultrasound observation apparatus **3** is connected to the ultrasound endoscope **2** via the connector **33a** and the monitor **4** is connected to the ultrasound endoscope **2** via the ultrasound observation apparatus **3**.

The insertion portion **10** includes a main part including a distal end rigid portion **11**, a bending portion **12** positioned at a rear end of the distal end rigid portion **11**, and a flexible tube portion **13** positioned at a rear end of the bending portion **12** and extending to the operation section **20**, the tube portion **13** having a small diameter, a long length and flexibility, which are continuously provided in this order from the distal end side.

As illustrated in FIG. **2**, an ultrasound probe **15** is disposed on the distal end side of the distal end rigid portion **11**. Furthermore, in a slant surface formed at a part of the distal end rigid portion **11** on the proximal side relative to the ultrasound probe **15**, an illumination lens **16** included in an illumination optical system, an observation lens **17** for an observation lens optical system, a forceps port **18** that doubles as a suction port and a non-illustrated air/water feeding nozzle are disposed.

At the operation section **20**, an angle knob **21** for performing bending control to bend the bending portion **12** in a desired direction, an air/water feeding button **22** for performing air feeding and water feeding operations, a suction button **23** for performing an suction operation, and a treatment instrument insertion port **24**, which is an entrance for a treatment instrument to be introduced into a body, are disposed. Here, the treatment instrument insertion port **24** connects to the forceps port **18** via a treatment instrument insertion channel (not illustrated) provided inside the insertion portion **10**.

As illustrated in FIGS. **2** to **5**, the ultrasound probe **15** in the present embodiment is a convex-type ultrasound probe, and the ultrasound probe **15** includes, for example, a transducer unit **50** that transmits/receives ultrasound, a cable unit **60** electrically connected to the transducer unit **50**, and a housing **70** that holds the transducer unit **50**.

The transducer unit **50** includes an ultrasound transmitting/receiving section **51** including a plurality of elongated ultrasound transducer elements **51a** arranged in a substantially arc-like shape as a result of respective long sides of the ultrasound transducer elements **51a** being jointed to one another. The ultrasound transmitting/receiving section **51** is housed in a protection cover **52** in which a substantially arc-like acoustic lens layer **52a** is provided in an integrated manner. Inside the protection cover **52**, the respective ultrasound transducer elements **51a** are arranged so as to face an inner face of the acoustic lens layer **52a** and are bonded to the inner face of the acoustic lens layer **52a** via an acoustic matching layer **53a**.

Also, inside the protection cover **52**, an end portion of a wiring board **55** is made to face the back side of the respective ultrasound transducer elements **51a**. On the end portion of the wiring board **55**, electrode portions **56a**, which correspond to

the respective ultrasound transducer elements **51a**, are provided, and the ultrasound transducer elements **51a** are electrically and mechanically connected to the electrode portions **56a** via wires **54**. Note that for the connection of the wires **54**, e.g., soldering is preferably used. Furthermore, inside the protection cover **52**, for example, an adhesive having a predetermined elasticity or the like is charged, whereby a back-side damping layer (backing layer) **53b** is formed, and the respective wires **54** are sealed by the back-side damping layer **53b**.

Here, for example, as illustrated in FIG. **6**, more specifically, the wiring board **55** includes a rigid circuit board **56**, which is a stiff portion, and a pair of flexible circuit boards **57** attached to opposite faces of the rigid circuit board **56**, respectively.

At each of the opposite faces of the rigid circuit board **56**, a wiring pattern including the aforementioned respective electrode portions **56a** and a plurality of pad electrodes **56b** electrically connected to the respective electrode portions **56a** are formed.

On one surface (inner side) of each flexible circuit board **57** that faces the rigid circuit board **56**, a plurality of inner electrode portions **57a**, which correspond to the pad electrodes **56b** are arranged, and on the other surface (outer) side, a wiring pattern in which a plurality of outer electrode portions **57b** electrically connected to the respective inner electrode portions **57a**, respectively, are arranged is formed. Furthermore, a protection sheet **58** extends out from each of the flexible circuit boards **57**, the protection sheet **58** having a shape substantially symmetrical to the flexible circuit board **57**. Furthermore, a strip-shaped wrapping portion **59** extends out from one of the flexible circuit boards **57**. The protection sheet **58** and the wrapping portion **59** include, for example, a sheet material having flexibility and an insulating property, and are formed integrally with the flexible circuit board **57**.

The inner sides of the respective flexible circuit boards **57** are bonded to the respective faces of the rigid circuit board **56**. The bonding of the flexible circuit boards **57** are performed by, for example, bonding the flexible circuit boards **57** to the rigid circuit board **56** via thermal compression bonding or soldering with the respective inner electrode portions **57a** on the flexible circuit board **57** positioned relative to the respective pad electrodes **56b** on the rigid circuit board **56**. As a result of bonding the flexible circuit boards **57** to the rigid circuit board **56**, the respective inner electrode portions **57a** on each of the flexible circuit boards **57** are electrically connected to the respective pad electrode **56b** on the rigid circuit board **56**. It is desirable that an adhesive used for the thermal compression bonding between the rigid circuit board **56** and the flexible circuit board **57** be a crosslinkable adhesive.

The cable unit **60** includes, for example, a wiring group resulting from a plurality of drive wirings **62**, which each include a small-diameter coaxial cable, being integrally bundled by an outer coat **61**. At a distal end portion of the cable unit **60**, the respective drive wirings **62** extend out branchingly from the outer coat **61**. Distal end portions of the respective separated drive wirings **62** are electrically connected to the respective outer electrode portions **57b**, respectively, on the outer sides of the respective flexible circuit board **57**. Through the connection with the respective outer electrode portions **57b**, the respective drive wirings **62** are electrically connected to the respective ultrasound transducer elements **51a**. Note that for the connection of the drive wirings **62**, e.g., soldering is preferably used.

Here, after the respective drive wirings **62** in the cable unit **60** are electrically connected to the respective outer electrode portions **57b**, the protection sheets **58** extending out from the

respective flexible circuit boards **57** are folded back so as to cover the respective outer electrode portions **57b**, and distal end portions of the protection sheets **58** are bonded to the rigid circuit board **56** via, for example, an adhesive **58a** (see FIG. 4). Consequently, portions of connection between the respective outer electrode portions **57b** and the respective drive wirings **62** are mechanically protected and electrically shielded.

Furthermore, the wrapping portion **59** extending out from one of the flexible circuit boards **57** is wound around peripheral portions of the respective drive wirings **62** exposed from the outer coat **61**, and, for example, a distal end portion of the wrapping portion **59** is bonded to a part at a certain position of the wrapping portion **59** via an adhesive **59a**. Consequently, the respective drive wirings **62** exposed from the outer coat **61** are integrally bundled by the wrapping portion **59** (see FIGS. 5 and 7), and the respective drive wirings **62** are mechanically protected and electrically shielded.

As illustrated in FIGS. 3 to 5, the housing **70** includes, for example, a member having a substantially U-shape in cross-section in which the housing portion **71** for the transducer unit **50** is provided in a recessed manner. On the proximal side of the housing **70**, a tubular wiring insertion portion **72** having a function as a connector for connection with the distal end rigid portion **11** is provided, and the inside of the wiring insertion portion **72** connects to the inside of the housing portion **71**.

Where the transducer unit **50** is assembled to such housing **70**, for example, as illustrated in FIG. 5, first, the proximal end side of the cable unit **60** is inserted into and through the wiring insertion portion **72** from the housing portion **71** side. Subsequently, the insertion work of pushing the respective drive wirings **62** integrally bundled by the wrapping portion **59** into the wiring insertion portion **72** and the work of housing the transducer unit **50** in the housing portion **71** are performed. Note that after the transducer unit **50** is housed in the housing portion **71**, and inside the housing portion **71**, for example, a resin adhesive **73** is charged through the wiring insertion portion **72**.

According to such embodiment as described above, the wiring board **55** electrically connected to the back side of the ultrasound transmitting/receiving section **51** that transmits/receives ultrasound includes the rigid circuit board **56**, which provides a stiff portion, and the wrapping portion **59** extending out from the rigid circuit board **56** (stiff portion), and the plurality of the drive wirings **62** electrically connected to the wiring board **55** are inserted into the wiring insertion portion **72** of the housing **70** with the drive wirings **62** wrapped and bundled by the wrapping portion **59**, enabling sufficient downsizing of the ultrasound probe **15** with a simple configuration and without losing the ease of assembly.

In other words, as a result of the plurality of drive wirings **62** being wrapped and bundled by the wrapping portion **59**, direct interference between, e.g., a mouth of the wiring insertion portion **70** and the respective drive wirings **62** can be avoided when the respective drive wirings **62** are pushed into the wiring insertion portion **72**. Accordingly, for example, when the ultrasound probe **15** is assembled, even if respective drive wirings **62** having an extremely small diameter are pressed to, e.g., the mouth of the wiring insertion portion **72** while the respective drive wirings **62** are bent at a relatively large curvature, e.g., mechanical damage of the respective drive wirings **62** can significantly be reduced. Accordingly, for example, reduction in distance from the transducer unit **50** to the mouth of the wiring insertion portion **72** and reduction

in diameter of the wiring insertion portion **72** can easily be achieved, enabling sufficient downsizing of the ultrasound probe **15**.

Here, in the configuration in which the respective drive wirings **62** are electrically connected to the rigid circuit board **56** via the flexible circuit boards **57**, the wrapping portion **59** is formed integrally with the relevant flexible circuit board **57**, enabling the wrapping portion **59** to extend out from the stiff portion (rigid circuit board **56**) with a simpler configuration and without use of, e.g., a dedicated sheet material. In addition, as a result of the wrapping portion **59** being formed integrally with the relevant flexible circuit board **57** as described above, there is no need to provide, e.g., a space for bonding the proximal end side of the wrapping portion **59** onto the rigid circuit board **56**, enabling downsizing of the wiring board **55** by that amount.

Furthermore, as a result of the protection sheet **58** for mechanically protecting and electrically insulating the portions of connection with the respective drive wirings **62** being made to extend out from each of the flexible circuit boards **57**, there is no need to provide a space for bonding the proximal end side of the protection sheet **58** on the rigid circuit board **56**, enabling downsizing of the wiring board **55** by that amount.

Although the above embodiment has been described in terms of an example of the configuration in which the wrapping portion **59** is provided at one of the pair of flexible circuit boards **57** and all of the respective drive wirings **62** connected to the respective flexible circuit boards **57** are integrally wrapped and bundled, as illustrated in FIG. 8, for example, a configuration in which a wrapping portion **59** is formed integrally with each of flexible circuit boards **57** and respective drive wirings **62** are wrapped and bundled by the respective flexible circuit boards **57** can be employed.

Furthermore, although the above embodiment has been described in terms of an example of the configuration in which the distal end portion of the wrapping portion **59** is bonded using the adhesive **59a**, for example, an adhesive tape (not illustrated) or the like can be used instead of the adhesive **59a**. Furthermore, for example, as illustrated in FIG. 9, a configuration in which slit portions **59b** are provided in a wrapping portion **59** and a wound wrapping state of the wrapping portion **59** is maintained by engagement of the slit portions **59b** can be employed.

In this type of ultrasound endoscope **2**, when an optical image of the inside of a subject is observed, it is desirable to prevent the ultrasound probe **15** from appearing in the optical image. For that purpose, in an ultrasound endoscope **2**, in general, an optical axis of an observation optical lens arranged in a distal end rigid portion **11** is arranged so as to be inclined upward relative to a longitudinal axis direction of the insertion portion **10** at a relatively sharp angle of around **35** to **55** degrees. However, in particular, in an ultrasound endoscope **2** employing an optical method in which an optical image is conveyed to the operation section **20** side using an image guide bundle **80**, if such inclined angle is provided in a narrow distal end rigid portion **11**, it is necessary to bend the image guide bundle **80** at a large curvature, resulting in a bending load on the bent region. On the other hand, setting a view angle of an obtained optical image to be small or setting a dimension in the longitudinal axis direction of the distal end rigid portion **11** to be large are not preferable from a practical perspective.

Therefore, in order to solve such problem, for example, in an observation optical lens system **81**, which is illustrated in FIGS. 10 and 11, an optical axis **O2** of an image guide bundle lens **83** fixed to a distal end portion of an image guide bundle

80 arranged so as to be offset from an optical axis **O1** of an objective lens group **82** including an observation lens **17** in an upward side. In order to achieve such offset state, in a sleeve **85** provided at the distal end portion of the image guide bundle **80**, a lens barrel **86** including a fitting portion **86a** for the sleeve **85** and a lens holding portion **86b** provided so as to be continuous with the fitting portion **86a**, which are decentered, is fitted. As a result of the image guide bundle lens **83** being held via the lens barrel **86**, for example, as illustrated in FIG. 3, even if the image guide bundle **80** is bent at a relatively small curvature, it is possible to prevent the ultrasound probe **15** from appearing on an optical image without setting an angle of view α to be small and setting the dimension in longitudinal axis direction of the distal end rigid portion **11** to be large (see the alternate long and short dash lines in FIG. 3). Note that in FIG. 3, the area indicated by the alternate long and two short dashes lines indicates an area that can be observed when the offset of the image guide bundle lens **83** is not performed as a comparative example.

Here, for example, as illustrated in FIGS. 12 and 13, such positioning of an image guide bundle lens **83** can also be achieved with reference to an outer circumferential face of a sleeve **87** decentered by decentering a hole of a sleeve **87** that receives an image guide bundle **80**. Furthermore, for example, as illustrated in FIGS. 14 and 15, the positioning of an image light guide bundle lens **83** can also be achieved with reference to a projection portion **85a** for positioning, which is provided at a portion of a distal end portion of a sleeve **85**.

Note that the present invention is not limited to the embodiment described above and various modification and alternations are possible and such modification and alternations also fall within the technical scope of the present invention.

What is claimed is:

1. An ultrasound endoscope comprising:
 - an ultrasound transducer configured to transmit and/or receive ultrasound;
 - a first drive wiring having a first portion and a second portion extending away from the first portion of the first drive wiring;
 - a main circuit board comprising:
 - a board material; and
 - a first main circuit pattern provided on the board material, wherein the first main circuit pattern electrically connects the ultrasound transducer and the first portion of the first drive wiring;
 - a first flexible sheet material attached to the main circuit board, the first flexible sheet material comprising:
 - a first protection portion arranged to extend away from the main circuit board and to cover the first portion of the first drive wiring; and
 - a first wrapping portion arranged to extend away from the first protection portion and to cover the second portion of the first drive wiring; and
 - a housing comprising:
 - a main circuit board housing portion configured to house the main circuit board, the first portion of the first drive wiring and the first protection portion of the first flexible sheet material; and
 - a tubular drive wiring insertion portion extending away from the main circuit board housing portion, wherein the tubular drive wiring insertion portion is configured to house the first wrapping portion of the first flexible sheet material and the second portion of the first drive wiring.
2. The ultrasound endoscope according to claim 1, further comprising:

a first flexible circuit pattern provided on the first flexible sheet material, wherein the first flexible circuit pattern electrically connects the ultrasound transducer and the first portion of the first drive wiring via the first main circuit pattern, wherein the first flexible circuit pattern comprises:

- a first flexible circuit pattern inner portion arranged on a first surface of the first flexible sheet material, wherein the first flexible circuit pattern inner portion is mechanically and electrically connected to the first main circuit pattern; and
- a first flexible circuit pattern outer portion arranged on a second surface of the first flexible sheet material, wherein the first flexible circuit pattern outer portion is mechanically and electrically connected to the first portion of the first drive wiring, wherein the first flexible circuit pattern inner portion is electrically connected to the first flexible circuit pattern outer portion, and wherein the first protection portion of the first flexible sheet material is arranged to cover the first flexible circuit pattern outer portion.

3. The ultrasound endoscope according to claim 1, wherein the ultrasound endoscope further comprises a second drive wiring having a third portion and a fourth portion extending away from the third portion of the second drive wiring;

- wherein the first main circuit pattern is arranged on a first surface of the board material, wherein the main circuit board further comprises a second main circuit pattern arranged on a second surface of the board material, wherein the second main circuit pattern electrically connects the ultrasound transducer and the third portion of the second drive wiring;
- wherein the first flexible sheet material is attached to the first surface of the board material; and
- wherein the ultrasound endoscope further comprises a second flexible sheet material attached to the second surface of the board material, the second flexible sheet material comprising a second protection portion arranged to extend away from the main circuit board and to cover the third portion of the second drive wiring.

4. The ultrasound endoscope according to claim 3, further comprising:

- a second flexible circuit pattern provided on the second flexible sheet material, wherein the second flexible circuit pattern electrically connects the ultrasound transducer and the third portion of the second drive wiring via the second main circuit pattern, wherein the second flexible circuit pattern comprises:
 - a second flexible circuit pattern inner portion arranged on a first surface of the second flexible sheet material, wherein the second flexible circuit pattern inner portion is mechanically and electrically connected to the second main circuit pattern; and
 - a second flexible circuit pattern outer portion arranged on a second surface of the second flexible sheet material, wherein the second flexible circuit pattern outer portion is mechanically and electrically connected to the third portion of the second drive wiring, wherein the second flexible circuit pattern inner portion is electrically connected to the second flexible circuit pattern outer portion, and wherein the second protection portion of the second flexible sheet material is arranged to cover the second flexible circuit pattern outer portion.

9

5. The ultrasound endoscope according to claim 3, wherein the first wrapping portion of the first flexible sheet material is arranged to extend away from the first protection portion and to cover the second portion of the first drive wiring and the fourth portion of the second drive wiring.

6. The ultrasound endoscope according to claim 3, wherein the second flexible sheet material further comprises a second wrapping portion arranged to extend away from the second protection portion and to cover the fourth portion of the second drive wiring.

7. The ultrasound endoscope according to claim 2,

wherein the ultrasound transducer, the first drive wiring, the main circuit board, the first flexible sheet material, the housing, and the first flexible circuit pattern form parts of an elongated insertion portion having a distal end and a proximal end that define an insertion axis,

wherein the ultrasound transducer comprises a plurality of ultrasound transducer elements configured to transmit and/or receive ultrasound, and

10

wherein each of the plurality of ultrasound transducer elements are arranged to transmit and/or receive ultrasound along one or more axes that intersect the insertion axis.

8. The ultrasound endoscope according to claim 7, further comprising a connection wire mechanically and electrically connecting at least one of the plurality of ultrasound transducer elements to the first main circuit pattern of the main circuit board,

wherein the first driving wire is mechanically and electrically connected to the first flexible circuit pattern outer portion, and arranged in the main circuit board housing portion and tubular drive wiring insertion portion to be substantially parallel to the insertion axis,

wherein the connection wire extends from the main circuit board towards the ultrasound transducer along an axis that intersects the insertion axis, and

wherein the first main circuit pattern and first flexible circuit pattern mechanically and electrically connect the connection wire and the first portion of the first drive wiring.

* * * * *

专利名称(译)	超声内窥镜		
公开(公告)号	US9050052	公开(公告)日	2015-06-09
申请号	US13/965414	申请日	2013-08-13
[标]申请(专利权)人(译)	奥林巴斯医疗株式会社		
申请(专利权)人(译)	奥林巴斯医疗系统股份有限公司.		
当前申请(专利权)人(译)	奥林巴斯医疗系统股份有限公司.		
[标]发明人	IRIE KEI		
发明人	IRIE, KEI		
IPC分类号	A61B8/14 A61B8/00 A61B8/12		
CPC分类号	A61B8/4444 A61B8/12 A61B8/445		
代理机构(译)	斯卡利SCOTT, 墨菲和压脚, P.C.		
审查员(译)	JUNG, UNSU		
优先权	2012186871 2012-08-27 JP		
其他公开文献	US20140058269A1		
外部链接	Espacenet USPTO		

摘要(译)

电连接到发送/接收超声波的超声波发送/接收部分的后侧的布线板包括刚性部分中包括的刚性电路板, 以及从刚性电路板(刚性部分)向外延伸的包裹部分, 以及电连接到布线板的多个驱动布线插入到壳体的布线插入部分中, 其中多个驱动布线被包裹部分包裹和捆扎。

