



US009011337B2

(12) **United States Patent**
Slayton et al.

(10) **Patent No.:** **US 9,011,337 B2**
(45) **Date of Patent:** **Apr. 21, 2015**

(54) **SYSTEMS AND METHODS FOR MONITORING AND CONTROLLING ULTRASOUND POWER OUTPUT AND STABILITY**

(75) Inventors: **Michael H. Slayton**, Tempe, AZ (US);
Paul Jaeger, Mesa, AZ (US)

(73) Assignee: **Guided Therapy Systems, LLC**, Mesa, AZ (US)

(*) Notice: Subject to any disclaimer, the term of this patent is extended or adjusted under 35 U.S.C. 154(b) by 0 days.

(21) Appl. No.: **13/547,011**

(22) Filed: **Jul. 11, 2012**

(65) **Prior Publication Data**
US 2013/0018286 A1 Jan. 17, 2013

Related U.S. Application Data
(60) Provisional application No. 61/506,609, filed on Jul. 11, 2011, provisional application No. 61/506,610, filed on Jul. 11, 2011.

(51) **Int. Cl.**
A61B 8/00 (2006.01)
A61N 7/00 (2006.01)
A61N 7/02 (2006.01)
A61B 18/00 (2006.01)

(52) **U.S. Cl.**
CPC ... *A61N 7/00* (2013.01); *A61N 7/02* (2013.01);
A61B 2018/00678 (2013.01); *A61B 2018/00732*
(2013.01); *A61B 2018/00779* (2013.01); *A61B*
2018/00791 (2013.01)

(58) **Field of Classification Search**
USPC 600/438, 439; 601/2, 3; 606/1, 31, 41,
606/42, 128
See application file for complete search history.

(56) **References Cited**

U.S. PATENT DOCUMENTS

2,427,348 A	9/1947	Bond et al.
3,913,386 A	10/1975	Saglio
3,965,455 A	6/1976	Hurwitz
3,992,925 A	11/1976	Perilhou
4,039,312 A	8/1977	Patru
4,059,098 A	11/1977	Murdock
4,101,795 A	7/1978	Fukumoto

(Continued)

FOREIGN PATENT DOCUMENTS

DE	4029175	3/1992
DE	10140064	3/2003

(Continued)

OTHER PUBLICATIONS

Arthur et al., "Non-invasive estimation of hyperthermia temperatures with ultrasound," *Int. J. Hyperthermia*, Sep. 2005, 21(6), pp. 589-600.

(Continued)

Primary Examiner — Michael Rozanski
(74) *Attorney, Agent, or Firm* — Quarles & Brady, LLP

(57) **ABSTRACT**

Some embodiments provide a method of providing ultrasound energy having a stable power output. The method can comprise providing ultrasound energy from a ultrasound transducer; determining a power level threshold of the ultrasound energy; monitoring a power level of the ultrasound energy over time of the ultrasound energy; communicating a power level to a controller; adjusting the frequency of the ultrasound energy upon a change in the power level; and maintaining the power level threshold of the ultrasound energy.

19 Claims, 4 Drawing Sheets

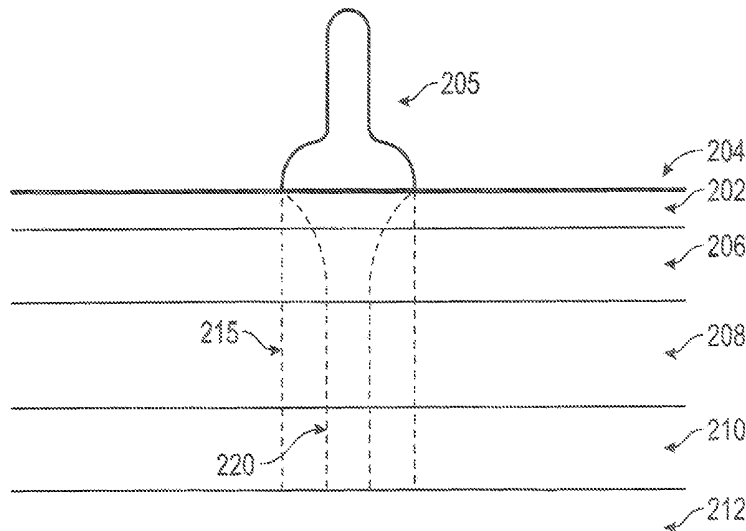

(56)

References Cited

U.S. PATENT DOCUMENTS

4,166,967 A	9/1979	Benes et al.	5,088,495 A	2/1992	Miyagawa
4,211,948 A	7/1980	Brisken et al.	5,115,814 A	5/1992	Griffith
4,211,949 A	7/1980	Brisken et al.	5,117,832 A	6/1992	Sanghvi
4,213,344 A	7/1980	Rose	5,123,418 A	6/1992	Saurel
4,276,491 A	6/1981	Daniel	5,143,063 A	9/1992	Fellner
4,315,514 A	2/1982	Drewes et al.	5,143,074 A	9/1992	Dory
4,325,381 A	4/1982	Glenn	5,149,319 A	9/1992	Unger
4,343,301 A	8/1982	Indech	5,150,711 A	9/1992	Dory
4,372,296 A	2/1983	Fahim	5,150,714 A	9/1992	Green
4,379,145 A	4/1983	Masuhō et al.	5,152,294 A	10/1992	Mochizuki et al.
4,381,007 A	4/1983	Doss	5,156,144 A	10/1992	Iwasaki
4,381,787 A	5/1983	Hottinger	5,158,536 A	10/1992	Sekins
4,397,314 A	8/1983	Vaguine	5,159,931 A	11/1992	Pini
4,409,839 A	10/1983	Taenzer	5,163,421 A	11/1992	Bernstein
4,431,008 A	2/1984	Wanner et al.	5,163,436 A	11/1992	Saitoh et al.
4,441,486 A	4/1984	Pounds	5,178,135 A	1/1993	Uchiyama et al.
4,452,084 A	6/1984	Taenzer	5,190,518 A	3/1993	Takasu
4,484,569 A	11/1984	Driller et al.	5,190,766 A	3/1993	Ishihara
4,507,582 A	3/1985	Glenn	5,191,880 A	3/1993	McLeod
4,513,749 A	4/1985	Kino et al.	5,205,287 A	4/1993	Erbel et al.
4,513,750 A	4/1985	Heyman et al.	5,209,720 A	5/1993	Unger
4,527,550 A	7/1985	Ruggera et al.	5,212,671 A	5/1993	Fujii et al.
4,528,979 A	7/1985	Marchenko et al.	5,215,680 A	6/1993	D Arrigo
4,534,221 A	8/1985	Fife et al.	5,224,467 A	7/1993	Oku
4,566,459 A	1/1986	Umemura et al.	5,230,334 A	7/1993	Klopotek
4,567,895 A	2/1986	Putzke	5,230,338 A	7/1993	Allen et al.
4,586,512 A	5/1986	Do-huu	5,247,924 A	9/1993	Suzuki et al.
4,601,296 A	7/1986	Yerushalmi	5,255,681 A	10/1993	Ishimura et al.
4,620,546 A	11/1986	Aida et al.	5,257,970 A	11/1993	Dougherty
4,637,256 A	1/1987	Sugiyama et al.	5,265,614 A	11/1993	Hayakawa
4,646,756 A	3/1987	Watmough	5,267,985 A	12/1993	Shimada et al.
4,663,358 A	5/1987	Hyon	5,269,297 A	12/1993	Weng
4,668,516 A	5/1987	Duraffourd et al.	5,282,797 A	2/1994	Chess
4,672,591 A	6/1987	Breimesser et al.	5,295,484 A	3/1994	Marcus
4,680,499 A	7/1987	Umemura et al.	5,295,486 A	3/1994	Wollschlager et al.
4,697,588 A	10/1987	Reichenberger	5,304,169 A	4/1994	Sand
4,754,760 A	7/1988	Fukukita et al.	5,305,756 A	4/1994	Entrekin et al.
4,757,820 A	7/1988	Itoh	5,321,520 A	6/1994	Inga et al.
4,771,205 A	9/1988	Mequio	5,323,779 A	6/1994	Hardy et al.
4,801,459 A	1/1989	Liburdy	5,327,895 A	7/1994	Hashimoto et al.
4,803,625 A	2/1989	Fu et al.	5,348,016 A	9/1994	Unger et al.
4,807,633 A	2/1989	Fry	5,360,268 A	11/1994	Hayashi
4,817,615 A	4/1989	Fukukita et al.	5,370,121 A	12/1994	Reichenberger
4,858,613 A	8/1989	Fry	5,371,483 A	12/1994	Bhardwaj
4,860,732 A	8/1989	Hasegawa et al.	5,375,602 A	12/1994	Lancee et al.
4,865,041 A	9/1989	Hassler	5,379,773 A	1/1995	Hornsby
4,865,042 A	9/1989	Umemura	5,380,280 A	1/1995	Peterson
4,867,169 A	9/1989	Machida	5,380,519 A	1/1995	Schneider et al.
4,874,562 A	10/1989	Hyon	5,383,917 A	1/1995	Desai et al.
4,875,487 A	10/1989	Seppi	5,391,140 A	2/1995	Schaetzle
4,891,043 A	1/1990	Zeimer et al.	5,391,197 A	2/1995	Burdette et al.
4,893,624 A	1/1990	Lele	5,392,259 A	2/1995	Bolorforosh
4,896,673 A	1/1990	Rose	5,396,143 A	3/1995	Seyed-Bolorforosh et al.
4,900,540 A	2/1990	Ryan et al.	5,398,689 A	3/1995	Connor et al.
4,901,729 A	2/1990	Saitoh et al.	5,406,503 A	4/1995	Williams, Jr. et al.
D306,965 S	4/1990	Jaworski	5,417,216 A	5/1995	Tanaka
4,917,096 A	4/1990	Englehart	5,419,327 A	5/1995	Rohwedder
4,932,414 A	6/1990	Coleman et al.	5,423,220 A	6/1995	Finsterwald et al.
4,938,216 A	7/1990	Lele	5,435,311 A	7/1995	Umemura
4,938,217 A	7/1990	Lele	5,438,998 A	8/1995	Hanafy
4,947,046 A	8/1990	Kawabata et al.	5,458,596 A	10/1995	Lax
4,951,653 A	8/1990	Fry	5,460,179 A	10/1995	Okunuki et al.
4,955,365 A	9/1990	Fry	5,460,595 A	10/1995	Hall et al.
4,958,626 A	9/1990	Nambu	5,469,854 A	11/1995	Unger et al.
4,976,709 A	12/1990	Sand	5,471,988 A	12/1995	Fujio
4,979,501 A	12/1990	Valchanov	5,487,388 A	1/1996	Rello et al.
4,992,989 A	2/1991	Watanabe et al.	5,492,126 A	2/1996	Hennige
5,012,797 A	5/1991	Liang	5,496,256 A	3/1996	Bock
5,018,508 A	5/1991	Fry et al.	5,501,655 A	3/1996	Rolt
5,030,874 A	7/1991	Saito et al.	5,503,152 A	4/1996	Oakley et al.
5,036,855 A	8/1991	Fry	5,503,320 A	4/1996	Webster et al.
5,040,537 A	8/1991	Katakura	5,507,790 A	4/1996	Weiss
5,054,310 A	10/1991	Flynn	5,520,188 A	5/1996	Hennige
5,054,470 A	10/1991	Fry	5,522,869 A	6/1996	Burdette
5,070,879 A	12/1991	Herres	5,523,058 A	6/1996	Umemura et al.
			5,524,620 A	6/1996	Rosenschein
			5,524,624 A	6/1996	Tepper
			5,524,625 A	6/1996	Okazaki et al.
			5,526,624 A	6/1996	Berg

(56)

References Cited

U.S. PATENT DOCUMENTS

5,526,812 A	6/1996	Dumoulin et al.	5,853,367 A	12/1998	Chalek et al.
5,526,814 A	6/1996	Cline et al.	5,869,751 A	2/1999	Bonin
5,526,815 A	6/1996	Granz	5,871,524 A	2/1999	Knowlton
5,529,070 A	6/1996	Augustine et al.	5,873,902 A	2/1999	Sanghvi
5,540,235 A	7/1996	Wilson	5,876,431 A	3/1999	Spehr et al.
5,558,092 A	9/1996	Unger	5,879,303 A	3/1999	Averkiou et al.
5,560,362 A	10/1996	Sliwa et al.	5,882,557 A	3/1999	Hayakawa
5,575,291 A	11/1996	Hayakawa	5,891,034 A	4/1999	Bucholz
5,575,807 A	11/1996	Faller	5,899,861 A	5/1999	Friemel et al.
5,577,502 A	11/1996	Darrow et al.	5,904,659 A	5/1999	Duarte
5,577,507 A	11/1996	Snyder et al.	5,919,219 A	7/1999	Knowlton
5,577,991 A	11/1996	Akui et al.	5,923,099 A	7/1999	Bilir
5,580,575 A	12/1996	Unger et al.	5,924,989 A	7/1999	Polz
5,601,526 A	2/1997	Chapelon	5,928,169 A	7/1999	Schatzle et al.
5,603,323 A	2/1997	Pflugrath et al.	5,931,805 A	8/1999	Brisken
5,609,562 A	3/1997	Kaali	5,938,606 A	8/1999	Bonnefous
5,615,091 A	3/1997	Palatnik	5,938,612 A	8/1999	Kline-Schoder
5,617,858 A	4/1997	Taverna et al.	5,948,011 A	9/1999	Knowlton
5,618,275 A	4/1997	Bock	5,957,844 A	9/1999	Dekel
5,620,479 A	4/1997	Diederich	5,957,882 A	9/1999	Nita et al.
5,622,175 A	4/1997	Sudol et al.	5,957,941 A	9/1999	Ream
5,638,819 A	6/1997	Manwaring et al.	5,967,980 A	10/1999	Ferre et al.
5,643,179 A	7/1997	Fujimoto	5,968,034 A	10/1999	Fullmer
5,644,085 A	7/1997	Lorraine et al.	5,971,949 A	10/1999	Levin
5,647,373 A	7/1997	Paltieli	5,977,538 A	11/1999	Unger et al.
5,655,535 A	8/1997	Friemel et al.	5,984,882 A	11/1999	Rosenschein
5,655,538 A	8/1997	Lorraine	5,990,598 A	11/1999	Sudol et al.
5,657,760 A	8/1997	Ying	5,997,471 A	12/1999	Gumb et al.
5,658,328 A	8/1997	Johnson	5,997,497 A	12/1999	Nita et al.
5,660,836 A	8/1997	Knowlton	5,999,843 A	12/1999	Anbar
5,662,116 A	9/1997	Kondo et al.	6,004,262 A	12/1999	Putz et al.
5,665,053 A	9/1997	Jacobs	6,007,499 A	12/1999	Martin et al.
5,665,141 A	9/1997	Vago	6,013,032 A	1/2000	Savord
5,671,746 A	9/1997	Dreschel et al.	6,016,255 A	1/2000	Bolan et al.
5,673,699 A	10/1997	Trahey et al.	6,019,724 A	2/2000	Gronningsaeter et al.
5,676,692 A	10/1997	Sanghvi	6,022,308 A	2/2000	Williams
5,685,820 A	11/1997	Riek et al.	6,022,327 A	2/2000	Chang
5,687,737 A	11/1997	Branham et al.	6,036,646 A	3/2000	Barthe
5,690,608 A	11/1997	Watanabe	6,039,048 A	3/2000	Silberg
5,694,936 A	12/1997	Fujimoto	6,039,689 A	3/2000	Lizzi
5,697,897 A	12/1997	Buchholtz	6,042,556 A	3/2000	Beach et al.
5,701,900 A	12/1997	Shehada et al.	6,049,159 A	4/2000	Barthe
5,704,361 A	1/1998	Seward et al.	6,050,943 A	4/2000	Slayton
5,706,252 A	1/1998	Le Verrier et al.	6,059,727 A	5/2000	Fowlkes
5,706,564 A	1/1998	Rhyne	6,071,239 A	6/2000	Cribbs
5,715,823 A	2/1998	Wood et al.	6,080,108 A	6/2000	Dunham
5,720,287 A	2/1998	Chapelon et al.	6,083,148 A	7/2000	Williams
5,722,411 A	3/1998	Suzuki	6,086,535 A	7/2000	Ishibashi
5,727,554 A	3/1998	Kalend et al.	6,086,580 A	7/2000	Mordon et al.
5,735,280 A	4/1998	Sherman et al.	6,090,054 A	7/2000	Tagishi
5,743,863 A	4/1998	Chapelon	6,093,883 A	7/2000	Sanghvi
5,746,005 A	5/1998	Steinberg	6,101,407 A	8/2000	Groezinger
5,746,762 A	5/1998	Bass	6,106,469 A	8/2000	Suzuki et al.
5,748,767 A	5/1998	Raab	6,113,558 A	9/2000	Rosenschein
5,749,364 A	5/1998	Sliwa et al.	6,113,559 A	9/2000	Klopotek
5,755,228 A	5/1998	Wilson et al.	6,120,452 A	9/2000	Barthe
5,755,753 A	5/1998	Knowlton	6,123,081 A	9/2000	Durette
5,762,066 A	6/1998	Law	6,126,619 A	10/2000	Peterson et al.
5,763,886 A	6/1998	Schulte	6,135,971 A	10/2000	Hutchinson et al.
5,769,790 A	6/1998	Watkins	6,139,499 A	10/2000	Wilk
5,779,644 A	7/1998	Eberle et al.	6,159,150 A	12/2000	Yale et al.
5,792,058 A	8/1998	Lee et al.	6,171,244 B1	1/2001	Finger et al.
5,795,297 A	8/1998	Daigle	6,176,840 B1	1/2001	Nishimura
5,795,311 A	8/1998	Wess	6,183,426 B1	2/2001	Akisada
5,810,009 A	9/1998	Mine et al.	6,183,502 B1	2/2001	Takeuchi
5,810,888 A	9/1998	Fenn	6,183,773 B1	2/2001	Anderson
5,814,599 A	9/1998	Mitragotri et al.	6,190,323 B1	2/2001	Dias et al.
5,817,013 A	10/1998	Ginn et al.	6,190,336 B1	2/2001	Duarte
5,817,021 A	10/1998	Reichenberger	6,193,658 B1	2/2001	Wendelken et al.
5,820,564 A	10/1998	Slayton	6,210,327 B1	4/2001	Brackett et al.
5,823,962 A	10/1998	Schaetzle	6,213,948 B1	4/2001	Barthe
5,827,204 A	10/1998	Grandia et al.	6,216,029 B1	4/2001	Paltieli
5,839,751 A	11/1998	Lutz	6,233,476 B1	5/2001	Strommer et al.
5,840,032 A	11/1998	Hatfield et al.	6,234,990 B1	5/2001	Rowe et al.
5,844,140 A	12/1998	Seale	6,241,753 B1	6/2001	Knowlton
			6,246,898 B1	6/2001	Vesely et al.
			6,251,074 B1	6/2001	Averkiou et al.
			6,251,088 B1	6/2001	Kaufman et al.
			6,268,405 B1	7/2001	Yao

(56)

References Cited

U.S. PATENT DOCUMENTS

6,273,864	B1	8/2001	Duarte	6,638,226	B2	10/2003	He et al.
6,280,402	B1	8/2001	Ishibashi et al.	6,645,162	B2	11/2003	Friedman
6,287,257	B1	9/2001	Maticchuk	6,662,054	B2	12/2003	Kreindel
6,296,619	B1	10/2001	Brisken	6,663,627	B2	12/2003	Francischelli
6,301,989	B1	10/2001	Brown et al.	6,665,806	B1	12/2003	Shimizu
6,309,355	B1	10/2001	Cain et al.	6,666,835	B2	12/2003	Martin
6,311,090	B1	10/2001	Knowlton	6,669,638	B1	12/2003	Miller et al.
6,315,741	B1	11/2001	Martin	6,685,640	B1	2/2004	Fry
6,322,509	B1	11/2001	Pan et al.	6,692,450	B1	2/2004	Coleman
6,322,532	B1	11/2001	D'Sa	6,699,237	B2	3/2004	Weber
6,325,540	B1	12/2001	Lounsbury et al.	6,716,184	B2	4/2004	Vaezy et al.
6,325,758	B1	12/2001	Carol et al.	6,719,449	B1	4/2004	Laugharn
6,325,769	B1	12/2001	Klopotek	6,719,694	B2	4/2004	Weng
6,325,798	B1	12/2001	Edwards et al.	6,726,627	B1	4/2004	Lizzi et al.
6,338,716	B1	1/2002	Hossack et al.	6,733,449	B1	5/2004	Krishnamurthy et al.
6,350,276	B1	2/2002	Knowlton	6,749,624	B2	6/2004	Knowlton
6,356,780	B1	3/2002	Licato et al.	6,773,409	B2	8/2004	Truckai et al.
6,361,531	B1	3/2002	Hissong	6,775,404	B1	8/2004	Pagoulatos et al.
6,370,411	B1	4/2002	Osadchy et al.	6,790,187	B2	9/2004	Thompson et al.
6,375,672	B1	4/2002	Aksan	6,824,516	B2	11/2004	Batten et al.
6,377,854	B1	4/2002	Knowlton	6,825,176	B2	11/2004	White et al.
6,377,855	B1	4/2002	Knowlton	6,835,940	B2	12/2004	Morikawa et al.
6,381,497	B1	4/2002	Knowlton	6,846,290	B2	1/2005	Lizzi et al.
6,381,498	B1	4/2002	Knowlton	6,875,176	B2	4/2005	Mourad et al.
6,387,380	B1	5/2002	Knowlton	6,882,884	B1	4/2005	Mosk et al.
6,390,982	B1	5/2002	Bova et al.	6,887,239	B2	5/2005	Elstrom
6,405,090	B1	6/2002	Knowlton	6,889,089	B2	5/2005	Behl
6,409,720	B1	6/2002	Hissong	6,896,657	B2	5/2005	Willis
6,413,216	B1	7/2002	Cain et al.	6,902,536	B2	6/2005	Manna
6,413,253	B1	7/2002	Koop	6,905,466	B2	6/2005	Salgo
6,413,254	B1	7/2002	Hissong	6,918,907	B2	7/2005	Kelly
6,419,648	B1	7/2002	Vitek	6,920,883	B2	7/2005	Besette
6,423,007	B2	7/2002	Lizzi et al.	6,921,371	B2	7/2005	Wilson
6,425,865	B1	7/2002	Salcudean	6,932,771	B2	8/2005	Whitmore
6,425,867	B1	7/2002	Vaezy	6,932,814	B2	8/2005	Wood
6,425,912	B1	7/2002	Knowlton	6,936,044	B2	8/2005	McDaniel
6,428,477	B1	8/2002	Mason	6,936,046	B2	8/2005	Hissong
6,428,532	B1	8/2002	Doukas	6,945,937	B2	9/2005	Culp et al.
6,430,446	B1	8/2002	Knowlton	6,948,843	B2	9/2005	Laugharn et al.
6,432,057	B1	8/2002	Mazess et al.	6,953,941	B2	10/2005	Nakano et al.
6,432,067	B1	8/2002	Martin	6,958,043	B2	10/2005	Hissong
6,432,101	B1	8/2002	Weber	6,971,994	B1	12/2005	Young et al.
6,436,061	B1	8/2002	Costantino	6,974,417	B2	12/2005	Lockwood
6,438,424	B1	8/2002	Knowlton	6,976,492	B2	12/2005	Ingle
6,440,071	B1	8/2002	Slayton	6,992,305	B2	1/2006	Maezawa et al.
6,440,121	B1	8/2002	Weber	6,997,923	B2	2/2006	Anderson
6,443,914	B1	9/2002	Costantino	7,006,874	B2	2/2006	Knowlton
6,453,202	B1	9/2002	Knowlton	7,020,528	B2	3/2006	Neev
6,461,378	B1	10/2002	Knowlton	7,022,089	B2	4/2006	Ooba
6,470,216	B1	10/2002	Knowlton	7,058,440	B2	6/2006	Heuscher et al.
6,488,626	B1	12/2002	Lizzi et al.	7,063,666	B2	6/2006	Weng
6,491,657	B2	12/2002	Rowe	7,070,565	B2	7/2006	Vaezy et al.
6,500,121	B1	12/2002	Slayton	7,074,218	B2	7/2006	Washington et al.
6,500,141	B1	12/2002	Irion	7,094,252	B2	8/2006	Koop
6,508,774	B1	1/2003	Acker	7,108,663	B2	9/2006	Talish et al.
6,511,427	B1	1/2003	Sliwa, Jr. et al.	7,115,123	B2	10/2006	Knowlton
6,511,428	B1	1/2003	Azuma	7,122,029	B2	10/2006	Koop et al.
6,514,244	B2	2/2003	Pope	7,142,905	B2	11/2006	Slayton
6,517,484	B1	2/2003	Wilk et al.	7,165,451	B1	1/2007	Brooks et al.
6,524,250	B1	2/2003	Weber	7,179,238	B2	2/2007	Hissong
6,540,679	B2	4/2003	Slayton	7,189,230	B2	3/2007	Knowlton
6,540,685	B1	4/2003	Rhoads et al.	7,229,411	B2	6/2007	Slayton
6,540,700	B1	4/2003	Fujimoto et al.	7,235,592	B2	6/2007	Muratoglu
6,554,771	B1	4/2003	Buil et al.	7,258,674	B2	8/2007	Cribbs
6,569,099	B1	5/2003	Babaev	7,273,459	B2	9/2007	Desilets
6,569,108	B2	5/2003	Sarvazyan et al.	7,294,125	B2	11/2007	Phalen et al.
6,572,552	B2	6/2003	Fukukita	7,297,117	B2	11/2007	Trucco et al.
6,575,956	B1	6/2003	Brisken et al.	7,303,555	B2	12/2007	Makin et al.
6,595,934	B1	7/2003	Hissong	7,327,071	B2	2/2008	Nishiyama et al.
6,599,256	B1	7/2003	Acker	7,331,951	B2	2/2008	Eshel et al.
6,607,498	B2	8/2003	Eshel	7,332,985	B2	2/2008	Larson, III et al.
6,618,620	B1	9/2003	Freundlich et al.	7,347,855	B2	3/2008	Eshel
6,623,430	B1	9/2003	Slayton	RE40,403	E	6/2008	Cho et al.
6,626,854	B2	9/2003	Friedman	7,393,325	B2	7/2008	Barthe
6,626,855	B1	9/2003	Weng	7,398,116	B2	7/2008	Edwards
				7,399,279	B2	7/2008	Abend et al.
				7,491,171	B2	2/2009	Barthe et al.
				7,510,536	B2	3/2009	Foley et al.
				7,530,356	B2	5/2009	Slayton

(56)

References Cited

U.S. PATENT DOCUMENTS

7,530,958 B2	5/2009	Slayton	2002/0128648 A1	9/2002	Weber
7,571,336 B2	8/2009	Barthe	2002/0143252 A1	10/2002	Dunne et al.
7,601,120 B2	10/2009	Moilanen et al.	2002/0156400 A1	10/2002	Babaev
7,615,015 B2	11/2009	Coleman	2002/0161357 A1	10/2002	Anderson
7,615,016 B2	11/2009	Barthe	2002/0165529 A1	11/2002	Danek
7,686,763 B2	3/2010	Vaezy et al.	2002/0168049 A1	11/2002	Schriever
7,695,437 B2	4/2010	Quistgaard et al.	2002/0169394 A1	11/2002	Eppstein et al.
7,758,524 B2	7/2010	Barthe	2002/0169442 A1	11/2002	Neev
7,789,841 B2	9/2010	Huckle et al.	2002/0173721 A1	11/2002	Grunwald et al.
7,824,348 B2	11/2010	Barthe et al.	2002/0193784 A1	12/2002	McHale et al.
7,846,096 B2	12/2010	Mast et al.	2002/0193831 A1	12/2002	Smith
7,857,773 B2	12/2010	Desilets et al.	2003/0009153 A1	1/2003	Brisken et al.
7,875,023 B2	1/2011	Eshel et al.	2003/0014039 A1	1/2003	Barzell et al.
7,914,453 B2	3/2011	Slayton et al.	2003/0018255 A1	1/2003	Martin
7,914,469 B2	3/2011	Torbati	2003/0028111 A1	2/2003	Vaezy et al.
7,931,611 B2	4/2011	Novak et al.	2003/0028113 A1	2/2003	Gilbert et al.
7,955,281 B2	6/2011	Pedersen et al.	2003/0032900 A1	2/2003	Ella
7,967,764 B2	6/2011	Lidgren et al.	2003/0036706 A1	2/2003	Slayton et al.
7,967,839 B2	6/2011	Flock et al.	2003/0040442 A1	2/2003	Yokouchi
8,057,389 B2	11/2011	Barthe et al.	2003/0040739 A1	2/2003	Koop
8,057,465 B2	11/2011	Sliwa, Jr. et al.	2003/0050678 A1	3/2003	Sierra
8,066,641 B2	11/2011	Barthe et al.	2003/0055417 A1	3/2003	Truckai et al.
8,123,707 B2	2/2012	Huckle et al.	2003/0060736 A1	3/2003	Martin et al.
8,128,618 B2	3/2012	Gliklich et al.	2003/0065313 A1	4/2003	Koop
8,133,180 B2	3/2012	Slayton et al.	2003/0074023 A1	4/2003	Kaplan
8,133,191 B2	3/2012	Rosenberg et al.	2003/0083536 A1	5/2003	Eshel
8,166,332 B2	4/2012	Barthe et al.	2003/0092988 A1	5/2003	Makin
8,197,409 B2	6/2012	Foley et al.	2003/0097071 A1	5/2003	Halmann et al.
8,206,299 B2	6/2012	Foley et al.	2003/0099383 A1	5/2003	Lefebvre
8,211,017 B2	7/2012	Foley et al.	2003/0125629 A1	7/2003	Ustuner
8,262,591 B2	9/2012	Pedersen et al.	2003/0139790 A1	7/2003	Ingle et al.
8,273,037 B2	9/2012	Kreindel et al.	2003/0171678 A1	9/2003	Batten et al.
8,282,554 B2	10/2012	Makin et al.	2003/0171701 A1	9/2003	Babaev
8,333,700 B1	12/2012	Barthe et al.	2003/0176790 A1	9/2003	Slayton
8,366,622 B2	2/2013	Slayton et al.	2003/0191396 A1	10/2003	Sanghvi
8,409,097 B2	4/2013	Slayton et al.	2003/0200481 A1	10/2003	Stanley
8,444,562 B2	5/2013	Barthe et al.	2003/0212129 A1	11/2003	Liu et al.
8,480,585 B2	7/2013	Slayton et al.	2003/0212351 A1	11/2003	Hissong
8,506,486 B2	8/2013	Slayton et al.	2003/0212393 A1	11/2003	Knowlton
8,523,775 B2	9/2013	Barthe et al.	2003/0216795 A1	11/2003	Harth
8,535,228 B2	9/2013	Slayton et al.	2003/0220536 A1	11/2003	Hissong
8,585,618 B2	11/2013	Hunziker et al.	2003/0220585 A1	11/2003	Hissong
8,636,665 B2	1/2014	Slayton et al.	2003/0229331 A1	12/2003	Brisken et al.
8,641,622 B2	2/2014	Barthe et al.	2003/0233085 A1	12/2003	Giammarusti
8,663,112 B2	3/2014	Slayton et al.	2003/0236487 A1	12/2003	Knowlton
8,672,848 B2	3/2014	Slayton et al.	2004/0000316 A1	1/2004	Knowlton
8,690,778 B2	4/2014	Slayton et al.	2004/0001809 A1	1/2004	Brisken
8,690,779 B2	4/2014	Slayton et al.	2004/0002705 A1	1/2004	Knowlton
8,690,780 B2	4/2014	Slayton et al.	2004/0010222 A1	1/2004	Nunomura et al.
8,708,935 B2	4/2014	Barthe et al.	2004/0015106 A1	1/2004	Coleman
8,715,186 B2	5/2014	Slayton et al.	2004/0030227 A1	2/2004	Littrup
8,726,781 B2	5/2014	Eckhoff et al.	2004/0039312 A1	2/2004	Hillstead
2001/0009997 A1	7/2001	Pope	2004/0039418 A1	2/2004	Elstrom et al.
2001/0009999 A1	7/2001	Kaufman et al.	2004/0041563 A1	3/2004	Lewin et al.
2001/0014780 A1	8/2001	Martin et al.	2004/0041880 A1	3/2004	Ikeda et al.
2001/0014819 A1	8/2001	Ingle et al.	2004/0042168 A1	3/2004	Yang et al.
2001/0031922 A1	10/2001	Weng et al.	2004/0044375 A1	3/2004	Diederich et al.
2001/0039380 A1	11/2001	Larson et al.	2004/0049134 A1	3/2004	Tosaya et al.
2001/0041880 A1	11/2001	Brisken	2004/0049734 A1	3/2004	Simske
2002/0000763 A1	1/2002	Jones	2004/0059266 A1	3/2004	Fry
2002/0002345 A1	1/2002	Marlinghaus	2004/0068186 A1	4/2004	Ishida et al.
2002/0040199 A1	4/2002	Klopotek	2004/0073107 A1	4/2004	Altshuler et al.
2002/0040442 A1	4/2002	Ishidera	2004/0073113 A1	4/2004	Salgo
2002/0052550 A1	5/2002	Madsen et al.	2004/0073115 A1	4/2004	Horzewski et al.
2002/0055702 A1	5/2002	Atala	2004/0073116 A1	4/2004	Smith
2002/0062077 A1	5/2002	Emmenegger et al.	2004/0073204 A1	4/2004	Ryan et al.
2002/0062142 A1	5/2002	Knowlton	2004/0077977 A1	4/2004	Ella et al.
2002/0072691 A1	6/2002	Thompson et al.	2004/0082857 A1	4/2004	Schonenberger et al.
2002/0082528 A1	6/2002	Friedman et al.	2004/0082859 A1	4/2004	Schaer
2002/0082529 A1	6/2002	Suorsa et al.	2004/0102697 A1	5/2004	Evron
2002/0082589 A1	6/2002	Friedman et al.	2004/0105559 A1	6/2004	Aylward et al.
2002/0087080 A1	7/2002	Slayton et al.	2004/0122323 A1	6/2004	Vortman et al.
2002/0095143 A1	7/2002	Key	2004/0122493 A1	6/2004	Ishibashi et al.
2002/0099094 A1	7/2002	Anderson	2004/0143297 A1	7/2004	Ramsey
2002/0115917 A1	8/2002	Honda et al.	2004/0152982 A1	8/2004	Hwang et al.
			2004/0158150 A1	8/2004	Rabiner et al.
			2004/0186535 A1	9/2004	Knowlton
			2004/0189155 A1	9/2004	Funakubo
			2004/0206365 A1	10/2004	Knowlton

(56)

References Cited

U.S. PATENT DOCUMENTS

2004/0210214	A1	10/2004	Knowlton	2007/0055155	A1	3/2007	Owen et al.
2004/0217675	A1	11/2004	Desilets	2007/0055156	A1	3/2007	Desilets et al.
2004/0249318	A1	12/2004	Tanaka	2007/0065420	A1	3/2007	Johnson
2004/0254620	A1	12/2004	Lacoste et al.	2007/0083120	A1	4/2007	Cain et al.
2004/0267252	A1	12/2004	Washington et al.	2007/0087060	A1	4/2007	Dietrich
2005/0033201	A1	2/2005	Takahashi	2007/0088245	A1	4/2007	Babaev et al.
2005/0033316	A1	2/2005	Kertz	2007/0088346	A1	4/2007	Mirizzi et al.
2005/0038340	A1	2/2005	Vaezy et al.	2007/0161902	A1	7/2007	Dan
2005/0055073	A1	3/2005	Weber	2007/0166357	A1	7/2007	Shaffer et al.
2005/0061834	A1	3/2005	Garcia et al.	2007/0167709	A1	7/2007	Slayton
2005/0070961	A1	3/2005	Maki et al.	2007/0208253	A1	9/2007	Slayton
2005/0074407	A1	4/2005	Smith	2007/0219604	A1	9/2007	Yaroslavsky et al.
2005/0080469	A1	4/2005	Larson	2007/0219605	A1	9/2007	Yaroslavsky et al.
2005/0091770	A1	5/2005	Mourad et al.	2007/0238994	A1	10/2007	Stecco et al.
2005/0096542	A1	5/2005	Weng et al.	2007/0239075	A1	10/2007	Rosenberg et al.
2005/0104690	A1	5/2005	Larson, III et al.	2007/0239079	A1	10/2007	Manstein et al.
2005/0113689	A1	5/2005	Gritzky	2007/0239142	A1	10/2007	Altshuler et al.
2005/0134314	A1	6/2005	Prather et al.	2008/0027328	A1	1/2008	Klopotek et al.
2005/0137656	A1	6/2005	Malak	2008/0039724	A1	2/2008	Seip et al.
2005/0143677	A1	6/2005	Young et al.	2008/0071255	A1	3/2008	Barthe
2005/0154313	A1	7/2005	Desilets	2008/0086054	A1	4/2008	Slayton
2005/0154314	A1	7/2005	Quistgaard	2008/0097253	A1	4/2008	Pedersen
2005/0154332	A1	7/2005	Zanelli	2008/0139974	A1	6/2008	Da Silva
2005/0154431	A1	7/2005	Quistgaard	2008/0146970	A1	6/2008	Litman et al.
2005/0187495	A1	8/2005	Quistgaard	2008/0167556	A1	7/2008	Thompson et al.
2005/0191252	A1	9/2005	Mitsui	2008/0183077	A1	7/2008	Moreau-Gobard et al.
2005/0193451	A1	9/2005	Quistgaard et al.	2008/0188745	A1	8/2008	Chen et al.
2005/0197681	A1	9/2005	Barolet et al.	2008/0195000	A1	8/2008	Spooner et al.
2005/0228281	A1	10/2005	Nefos	2008/0200810	A1	8/2008	Buchalter
2005/0240170	A1	10/2005	Zhang et al.	2008/0200813	A1	8/2008	Quistgaard
2005/0251120	A1	11/2005	Anderson et al.	2008/0214966	A1	9/2008	Slayton
2005/0256406	A1	11/2005	Barthe	2008/0221491	A1	9/2008	Slayton
2005/0261584	A1	11/2005	Eshel	2008/0223379	A1	9/2008	Stunker et al.
2005/0261585	A1	11/2005	Makin et al.	2008/0243035	A1	10/2008	Crunkilton
2005/0267454	A1	12/2005	Hissong	2008/0269608	A1	10/2008	Anderson et al.
2005/0288748	A1	12/2005	Li et al.	2008/0275342	A1	11/2008	Barthe
2006/0004306	A1	1/2006	Altshuler	2008/0281206	A1	11/2008	Bartlett et al.
2006/0020260	A1	1/2006	Dover et al.	2008/0281236	A1	11/2008	Eshel et al.
2006/0025756	A1	2/2006	Francischelli	2008/0281237	A1	11/2008	Slayton
2006/0042201	A1	3/2006	Curry	2008/0281255	A1	11/2008	Slayton
2006/0058664	A1	3/2006	Barthe	2008/0294073	A1	11/2008	Barthe
2006/0058671	A1	3/2006	Vitek et al.	2008/0319356	A1	12/2008	Cain et al.
2006/0058707	A1	3/2006	Barthe	2009/0005680	A1	1/2009	Jones et al.
2006/0058712	A1	3/2006	Altshuler et al.	2009/0012394	A1	1/2009	Hobelsberger et al.
2006/0074309	A1	4/2006	Bonnefous	2009/0043198	A1	2/2009	Milner et al.
2006/0074313	A1	4/2006	Slayton et al.	2009/0043293	A1	2/2009	Pankratov et al.
2006/0074314	A1	4/2006	Slayton	2009/0069677	A1	3/2009	Chen et al.
2006/0074355	A1	4/2006	Slayton	2009/0093737	A1	4/2009	Chomas et al.
2006/0079816	A1	4/2006	Barthe	2009/0156969	A1	6/2009	Santangelo
2006/0079868	A1	4/2006	Makin	2009/0171252	A1	7/2009	Bockenstedt et al.
2006/0084891	A1	4/2006	Barthe	2009/0177122	A1	7/2009	Peterson
2006/0089632	A1	4/2006	Barthe	2009/0177123	A1	7/2009	Peterson
2006/0089688	A1	4/2006	Panescu	2009/0182231	A1	7/2009	Barthe et al.
2006/0094988	A1	5/2006	Tosaya et al.	2009/0216159	A1	8/2009	Slayton et al.
2006/0111744	A1	5/2006	Makin	2009/0226424	A1	9/2009	Hsu
2006/0116583	A1	6/2006	Ogasawara et al.	2009/0227910	A1	9/2009	Pedersen et al.
2006/0116671	A1	6/2006	Slayton	2009/0253988	A1	10/2009	Slayton et al.
2006/0122508	A1	6/2006	Slayton	2009/0299175	A1	12/2009	Bernstein et al.
2006/0122509	A1	6/2006	Desilets	2009/0318909	A1	12/2009	Debenedictis et al.
2006/0161062	A1	7/2006	Arditi	2010/0011236	A1	1/2010	Barthe et al.
2006/0184069	A1	8/2006	Vaitekunas	2010/0022919	A1	1/2010	Peterson
2006/0184071	A1	8/2006	Klopotek	2010/0022922	A1	1/2010	Barthe et al.
2006/0189972	A1	8/2006	Grossman	2010/0042020	A1	2/2010	Ben-Ezra
2006/0206105	A1	9/2006	Chopra	2010/0049178	A1	2/2010	Deem et al.
2006/0229514	A1	10/2006	Wiener	2010/0063422	A1	3/2010	Hynynen et al.
2006/0241440	A1	10/2006	Eshel	2010/0130891	A1	5/2010	Taggart et al.
2006/0241442	A1	10/2006	Barthe	2010/0160782	A1	6/2010	Slayton et al.
2006/0241470	A1	10/2006	Novak et al.	2010/0160837	A1	6/2010	Hunziker et al.
2006/0250046	A1	11/2006	Koizumi et al.	2010/0168576	A1	7/2010	Poland et al.
2006/0261584	A1	11/2006	Blackburn	2010/0191120	A1	7/2010	Kraus et al.
2006/0282691	A1	12/2006	Barthe	2010/0241035	A1	9/2010	Barthe et al.
2006/0291710	A1	12/2006	Wang et al.	2010/0280420	A1	11/2010	Barthe et al.
2007/0032784	A1	2/2007	Gliklich et al.	2010/0286518	A1	11/2010	Lee et al.
2007/0035201	A1	2/2007	Desilets	2011/0040171	A1	2/2011	Foley et al.
2007/0055154	A1	3/2007	Torbati	2011/0040190	A1	2/2011	Jahnke et al.
				2011/0087099	A1	4/2011	Eshel et al.
				2011/0087255	A1	4/2011	Mccormack et al.
				2011/0112405	A1	5/2011	Barthe et al.
				2011/0178444	A1	7/2011	Slayton et al.

(56)

References Cited

U.S. PATENT DOCUMENTS

2011/0190745 A1 8/2011 Uebelhoer et al.
 2011/0264012 A1 10/2011 Lautzenhiser et al.
 2012/0004549 A1 1/2012 Barthe et al.
 2012/0016239 A1 1/2012 Barthe et al.
 2012/0029353 A1 2/2012 Slayton et al.
 2012/0035475 A1 2/2012 Barthe et al.
 2012/0035476 A1 2/2012 Barthe et al.
 2012/0046547 A1 2/2012 Barthe et al.
 2012/0053458 A1 3/2012 Barthe et al.
 2012/0111339 A1 5/2012 Barthe et al.
 2012/0143056 A1 6/2012 Slayton et al.
 2012/0165668 A1 6/2012 Slayton et al.
 2012/0165848 A1 6/2012 Slayton et al.
 2012/0197120 A1 8/2012 Makin et al.
 2012/0197121 A1 8/2012 Slayton et al.
 2012/0215105 A1 8/2012 Slayton et al.
 2012/0271294 A1 10/2012 Barthe et al.
 2012/0296240 A1 11/2012 Azhari et al.
 2012/0316426 A1 12/2012 Foley et al.
 2012/0330197 A1 12/2012 Makin et al.
 2012/0330222 A1 12/2012 Barthe et al.
 2012/0330223 A1 12/2012 Makin et al.
 2013/0012755 A1 1/2013 Slayton
 2013/0012816 A1 1/2013 Slayton et al.
 2013/0012838 A1 1/2013 Jaeger et al.
 2013/0012842 A1 1/2013 Barthe
 2013/0018286 A1 1/2013 Slayton et al.
 2013/0046209 A1 2/2013 Slayton et al.
 2013/0066208 A1 3/2013 Barthe et al.
 2013/0066237 A1 3/2013 Smotrich et al.
 2013/0072826 A1 3/2013 Slayton et al.
 2013/0096471 A1 4/2013 Slayton et al.
 2013/0190659 A1 7/2013 Slayton et al.
 2013/0211258 A1 8/2013 Barthe et al.
 2013/0281853 A1 10/2013 Slayton et al.
 2013/0281891 A1 10/2013 Slayton et al.
 2013/0296697 A1 11/2013 Slayton et al.
 2013/0296700 A1 11/2013 Slayton et al.
 2013/0303904 A1 11/2013 Barthe et al.
 2013/0303905 A1 11/2013 Barthe et al.
 2013/0310863 A1 11/2013 Barthe et al.
 2014/0082907 A1 3/2014 Barthe
 2014/0142430 A1 5/2014 Slayton et al.
 2014/0148834 A1 5/2014 Barthe et al.
 2014/0180174 A1 6/2014 Slayton et al.
 2014/0187944 A1 7/2014 Slayton et al.
 2014/0188015 A1 7/2014 Slayton et al.
 2014/0188145 A1 7/2014 Slayton et al.

FOREIGN PATENT DOCUMENTS

DE 10219217 11/2003
 DE 10219297 11/2003
 DE 20314479 3/2004
 EP 0344773 12/1989
 EP 1479412 11/1991
 EP 0473553 4/1992
 EP 0661029 7/1995
 EP 1050322 11/2000
 EP 1234566 8/2002
 EP 1262160 12/2002
 EP 1374944 A 1/2004
 GB 2113099 8/1983
 JP 63036171 2/1988
 JP 03048299 3/1991
 JP 3123559 5/1991
 JP 03136642 6/1991
 JP 4089058 3/1992
 JP 04150847 5/1992
 JP 7080087 3/1995
 JP 07505793 6/1995
 JP 7222782 8/1995
 JP 09047458 2/1997
 JP 11505440 5/1999

JP 11506636 6/1999
 JP 2000166940 6/2000
 JP 2001170068 6/2001
 JP 2002515786 5/2002
 JP 2002521118 7/2002
 JP 2002537939 11/2002
 JP 2003050298 2/2003
 JP 2002078764 3/2003
 JP 2003204982 7/2003
 JP 2004147719 5/2004
 JP 2005503388 2/2005
 JP 2005527336 9/2005
 JP 2005323213 11/2005
 JP 2006520247 9/2006
 JP 2007505793 A 3/2007
 JP 2009518126 5/2009
 JP 2010517695 5/2010
 KR 1020010024871 3/2001
 KR 100400870 B1 10/2003
 KR 1020060113930 11/2006
 KR 1020070065332 6/2007
 KR 1020070070161 7/2007
 KR 1020070098856 10/2007
 KR 1020070104878 10/2007
 KR 1020070114105 11/2007
 WO 9625888 8/1996
 WO 9639079 A1 12/1996
 WO 9735518 10/1997
 WO 9832379 7/1998
 WO 9933520 7/1999
 WO 9949788 10/1999
 WO 0006032 2/2000
 WO 0015300 3/2000
 WO 0021612 4/2000
 WO 0053113 9/2000
 WO 0128623 4/2001
 WO 0182777 11/2001
 WO 0182778 11/2001
 WO 0187161 11/2001
 WO 0209813 2/2002
 WO 02024050 3/2002
 WO 02092168 A 11/2002
 WO 020292168 11/2002
 WO 03053266 A 7/2003
 WO 03065347 8/2003
 WO 03070105 8/2003
 WO 03077833 8/2003
 WO 03086215 10/2003
 WO 03096883 11/2003
 WO 03099177 12/2003
 WO 03101530 12/2003
 WO 2004000116 A 12/2003
 WO 2004080147 9/2004
 WO 2004110558 12/2004
 WO 2005011804 A2 2/2005
 WO 2005065408 7/2005
 WO 2005090978 9/2005
 WO 2006036870 4/2006
 WO 2006042163 A2 4/2006
 WO 2006042168 4/2006
 WO 2006042201 4/2006
 WO 2006065671 6/2006
 WO 2006082573 8/2006
 WO 2007067563 A 6/2007
 WO 2008024923 A2 2/2008
 WO 2008036622 A 3/2008
 WO 2009013729 1/2009
 WO 2009149390 A1 12/2009
 WO 2014055708 A1 4/2014

OTHER PUBLICATIONS

Chen, L. et al., "Effect of Blood Perfusion on the ablation of liver parenchyma with high intensity focused ultrasound," Phys. Med. Biol; 38:1661-1673; 1993b.
 Damianou et al., Application of the Thermal Dose Concept for Predicting the Necrosed Tissue Volume During Ultrasound Surgery, 1993 IEEE Ultrasound Symposium, pp. 1199-1202.

(56)

References Cited

OTHER PUBLICATIONS

- Fry, W.J. et al., "Production of Focal Destructive Lesions in the Central Nervous System with Ultrasound," *J. Neurosurg.*, 11:471-478; 1954.
- Harr, G.R. et al., "Tissue Destruction with Focused Ultrasound in Vivo," *Eur. Urol.* 23 (suppl. 1):8-11; 1993.
- Jeffers et al., "Evaluation of the Effect of Cavitation Activity on Drug-Ultrasound Synergisms," 1993 IEEE Ultrasonics Symposium, pp. 925-928.
- Madersbacher, S. et al., "Tissue Ablation in Bening Prostatic Hyperplasia with High Intensity Focused Ultrasound," *Dur. Urol.*, 23 (suppl. 1):39-43; 1993.
- Saad et al., "Ultrasound-Enhanced Effects of Adriamycin Against Murine Tumors," *Ultrasound in Med. & Biol.* vol. 18, No. 8, pp. 715-723 (1992).
- Simon et al., "Applications of Lipid-Coated Microbubble Ultrasonic Contrast to Tumor Therapy," *Ultrasound in Med. & Biol.* vol. 19, No. 2, pp. 123-125 (1993).
- Talbert, D. G., "An Add-On Modification for Linear Array Real-Time Ultrasound Scanners to Produce 3D Displays," *UTS Int'l 1977 Brighton, England* (Jun. 28-30, 1977) pp. 57-67.
- Tata et al., "Interaction of Ultrasound and Model Membrane Systems: Analyses and Predictions," American Chemical Society, *Phys. Chem.* 1992, 96, pp. 3548-3555.
- Alster, Tinas S., Tanzi, Elizabeth L., "Cellulite Treatment using a Novel Combination Radiofrequency, Infrared Light, and Mechanical Tissue Manipulation Device," *Journal of Cosmetic & Laser Therapy*, Jun. 2005, vol. 7, Issue 2, pp. 81-85.
- Barthe et al., "Ultrasound therapy system and ablation results utilizing miniature imaging/therapy arrays," *Ultrasonics Symposium*, 2004 IEEE, Aug. 23, 2004, pp. 1792-1795, vol. 3.
- Coon, Joshua et al., "Protein identification using sequential ion/ion reactions and tandem mass spectrometry" *Proceedings of the National Academy of Sciences of the USA*, vol. 102, No. 27, Jul. 5, 2005, pp. 9463-9468.
- Corry, Peter M., et al., "Human Cancer Treatment with Ultrasound", *IEEE Transactions on Sonics and Ultrasonics*, vol. SU-31, No. 5, Sep. 1984, pp. 444,456.
- Daum et al., "Design and Evaluation of a Feedback Based Phased Array System for Ultrasound Surgery," *IEEE Transactions on Ultrasonics, Ferroelectrics, and Frequency Control*, vol. 45, No. 2, Mar. 1998, pp. 431-438.
- Davis, Brian J., et al., "An Acoustic Phase Shift Technique for the Non-Invasive Measurement of Temperature Changes in Tissues", *1985 Ultrasonics Symposium*, pp. 921-924.
- Gliklich et al., *Clinical Pilot Study of Intense Ultrasound therapy to Deep Dermal Facial Skin and Subcutaneous Tissues*, *Arch Facial Plastic Surgery*, Mar. 1, 2007, vol. 9.
- Hassan et al., "Structure and Applications of Poly(vinyl alcohol) Hydrogels Produced by Conventional Crosslinking or by Freezing/Thawing Methods," *advanced in Polymer Science*, 2000, pp. 37-65, vol. 153.
- Hassan et al., "Structure and Morphology of Freeze/Thawed PVA Hydrogels," *Macromolecules*, Mar. 11, 2000, pp. 2472-2479, vol. 33, No. 7.
- Husseini et al., "The Role of Cavitation in Acoustically Activated Drug Delivery," *J. Control Release*, Oct. 3, 2005, pp. 253-261, vol. 107(2).
- Husseini et al. "Investigating the mechanism of acoustically activated uptake of drugs from Pluronic micelles," *BMD Cancer* 2002, 2:20k, Aug. 30, 2002, pp. 1-6.
- Jenne, J., et al., "Temperature Mapping for High Energy US-Therapy", 1994 Ultrasonics Symposium, pp. 1879-1882.
- Johnson, S.A., et al., "Non-Intrusive Measurement of Microwave and Ultrasound-Induced Hyperthermia by Acoustic temperature Tomography", *Ultrasonics Symposium Proceedings*, pp. 977-982.
- Makin et al., "B-Scan Imaging and Thermal Lesion Monitoring Using Miniaturized Dual-Functionality Ultrasound Arrays," *Ultrasonics Symposium*, 2004 IEEE, Aug. 23, 2004, pp. 1788-1791, vol. 3.
- Makin et al., "Miniaturized Ultrasound Arrays for Interstitial Ablation and Imaging," *UltraSound Med. Biol.* 2005, Nov. 1, 2005, pp. 1539-1550, vol. 31(11).
- Makin et al., "Confirmal Bulk Ablation and Therapy Monitoring Using Intracorporeal Image-Treat Ultrasound Arrays", 4th International Symposium on Therapeutic Ultrasound, Sep. 19, 2004.
- Manohar et al., "Photoacoustic mammography laboratory prototype: imaging of breast tissue phantoms," *Journal of Biomedical Optics*, Nov./Dec. 2004, pp. 1172-1181, vol. 9, No. 6.
- Mast et al., "Bulk Ablation of Soft Tissue with Intense Ultrasound; Modeling nad Experiments," *J. Acoust. Soc. Am.*, Oct. 1, 2005, pp. 2715-2724, vol. 118(4).
- Paradossi et al., "Poly(vinyl alcohol) as versatile biomaterial for potential biomedical applications," *Journal of Materials Science: Materials in Medicine*, 2003, pp. 687-691, vol. 14.
- Reid, Gavin, et al., "Tandem Mass spectrometry of ribonuclease A and B: N-linked glycosylation site analysis of whole protein ions," *Analytical Chemistry*. Feb. 1, 2002, vol. 74, No. 3, pp. 577-583.
- Righetti et al., "Elastographic Characterization of HIFU-Induced Lesions in Canine Livers," 1999, *Ultrasound in Med & Bio*, vol. 25, No. 7, pp. 1099-1113.
- Mitragotri, Samir; "Healing sound: the use of ultrasound in drug delivery and other therapeutic applications," *Nature Reviews; Drug Delivery*, pp. 255-260, vol. 4.
- Sanghvi, N. T., et al., "Transrectal Ablation of Prostrate Tissue Using Focused Ultrasound," 1993 *Ultrasonics Symposium*, IEEE, pp. 1207-1210.
- Seip, Ralf, et al., "Noninvasive Detection of Thermal Effects Due to Highly Focused Ultrasonic Fiels," *IEEE Symposium*, pp. 1229-1232, vol. 2, Oct. 3-Nov. 1993.
- Seip, Ralf, et al., "Noninvasive Estimation of Tissue Temperature Response to Heating Fields Using Diagnostic Ultrasound," *IEEE Transactions on Biomedical Engineering*, vol. 42, No. 8, Aug. 1995, pp. 828-839.
- Smith, Nadine Barrie, et al., "Non-Invasive in Vivo Temperature Mapping of Ultrasound Heating Using Magnetic Resonance Techniques", 1994 *Ultrasonics Symposium*, pp. 1829-1832, vol. 3.
- Surry et al., "Poly(vinyl alcohol) cryogel phantoms for use in ultrasound and MR imaging," *Phys. Med. Biol.*, Dec. 6, 2004, pp. 5529-5546, vol. 49.
- Syka J. E. P. et al., "Peptide and Protein Sequence Analysis by Electron Transfer Dissociation Mass Spectrometry," *Proceedings of the National Academy of Sciences of USA*, National Academy of Aceince, Washington, DC, vol. 101, No. 26, Jun. 29, 2004, pp. 9528-9533.
- Ueno, S., et al., "Ultrasound Thermometry in Hyperthermia", 1990 *Ultrasonic Symposium*, pp. 1645-1652.
- Wang, H., et al., "Limits on Focused Ultrasound for Deep Hyperthermia", 1994 *Ultrasonic Symposium*, Nov. 1-4, 1994, pp. 1869-1872, vol. 3.
- White et al "Selective Creation of Thermal Injury Zones in the Superficial Musculoaponeurotic System Using Intense Ultrasound Therapy," *Arch Facial Plastic Surgery*, Jan./Feb. 2007, vol. 9, No. 1.
- Sassen, Sander, "ATI's R520 architecture, the new king of the hill?" <http://www.hardwareanalysis.com/content/article/1813>, Sep. 16, 2005, 2 pages.
- Wasson, Scott, "NVIDIA's GeForce 7800 GTX graphics processor Power MADD," <http://techreport.com/reviews/2005q2/geforce-7800gtx/index.x?pg=1>, Jun. 22, 2005, 4 pages.
- European Examination Report in related Application No. 05808908.7 dated Jun. 29, 2009.
- European Examination Report in related Application No. 05810308.6 dated Jun. 29, 2009.
- European Examination Report in related Application No. 10185100.4 dated Jan. 6, 2014.
- European Examination Report in related Application No. 10185120.2 dated Jan. 22, 2014.
- Decision of the Korean Intellectual Property Tribunal dated Jun. 28, 2013 regarding Korean Patent No. 10-1142108, which is related to the pending application and/or an application identified in the Table on the pp. 2-5 of the information Disclosure Statement herein (English translation, English translation certification, and Korean decision included).

(56)

References Cited

OTHER PUBLICATIONS

International Search Report and Written Opinion dated Jan. 23, 2014 in Application No. PCT/US2012/046122.
International Search Report and Written Opinion dated Jan. 23, 2014 in Application No. PCT/US2012/046123.
International Search Report and Written Opinion dated Jan. 28, 2012 in Application No. PCT/US2012/046327.
International Search Report and Written Opinion dated Jan. 28, 2013 in Application No. PCT/US2012/046125.
International Search Report and Written Opinion dated Feb. 14, 2013 in Application No. PCT/US2011/001361.
International Search Report and Written Opinion dated Feb. 14, 2013 in Application No. PCT/US2011/001362.
International Search Report and Written Opinion dated Feb. 14, 2013 in Application No. PCT/US2011/001366.
International Search Report and Written Opinion dated Apr. 6, 2012 in Application No. PCT/US2011/001367.

Calderhead, et al., One Mechanism Behind LED Photo-Therapy for Wound Healing and Skin Rejuvenation: Key Role of the Mast Cell, *Laser Therapy*, 2008, 17.3:141-148.
PCT International Preliminary Report on Patentability, PCT/US2011/001366, Feb. 14, 2013, 6 pages.
European Patent Office, Extended Search Report, EP 09835856.7, Apr. 11, 2014, 6 pages.
PCT International Search Report and Written Opinion, PCT/US2014/030779, Sep. 1, 2014, 8 pages.
European Patent Office, Examination Report, EP 07814933.3, Aug. 5, 2014, 5 pages.
European Patent Office, Examination Report, EP 05798870.1, Oct. 20, 2014, 5 pages.
European Patent Office, Examination Report, EP 10185100.4, Oct. 24, 2014, 4 pages.
European Patent Office, Examination Report, EP 10185112.9, Oct. 24, 2014, 5 pages.
European Patent Office, Examination Report, EP 10185117.8, Oct. 24, 2014, 5 pages.
European Patent Office, Examination Report, EP 10185120.2, Oct. 24, 2014, 4 pages.

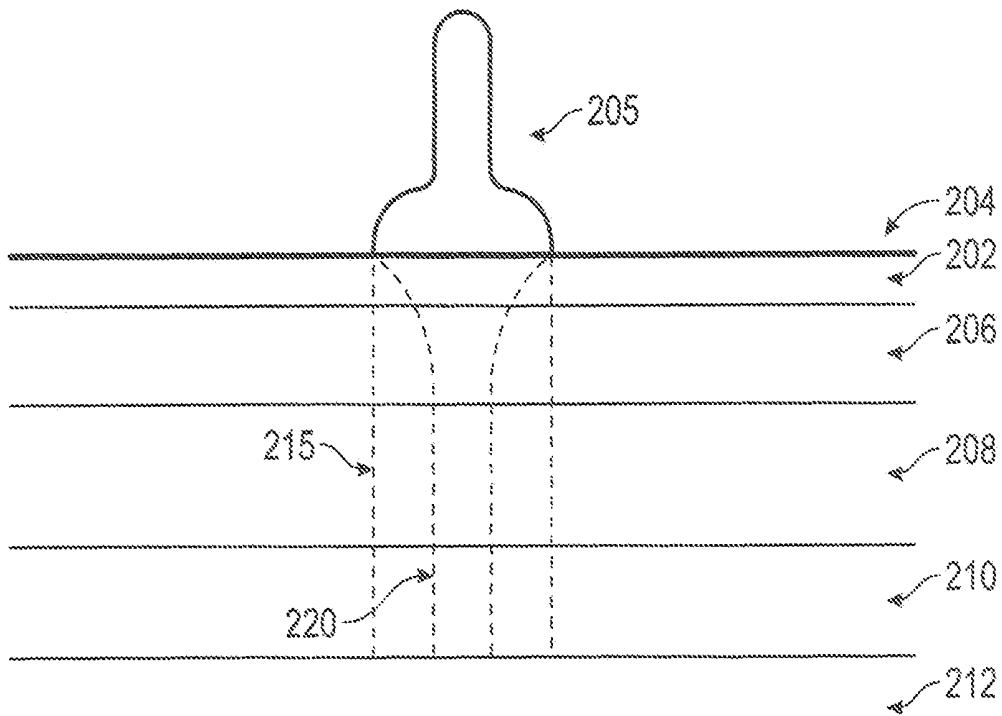

FIG. 1

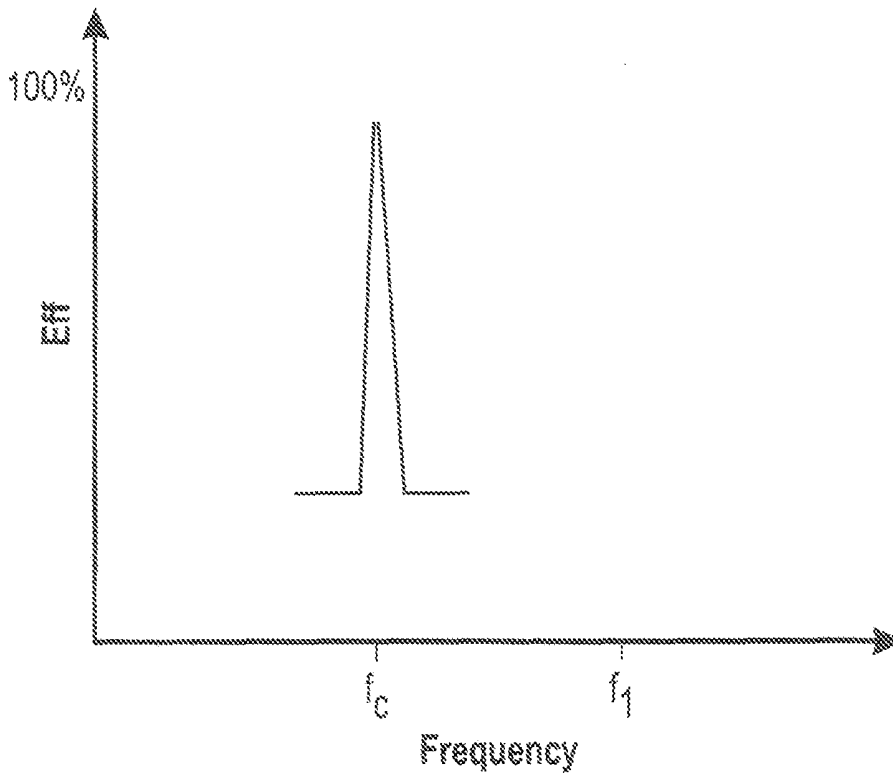

FIG. 2

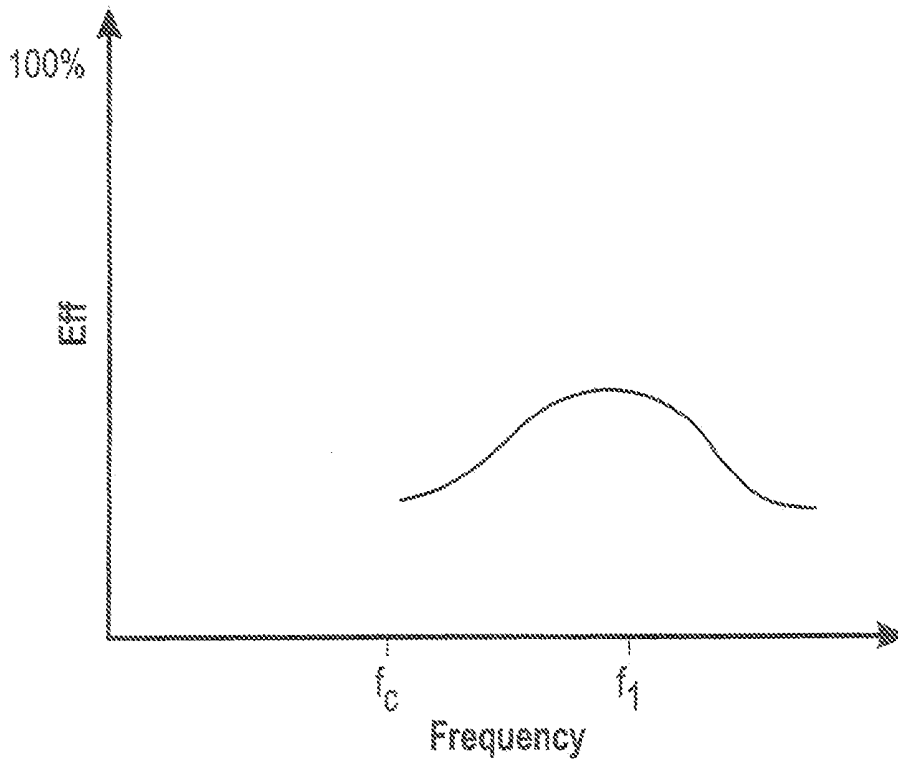

FIG. 3

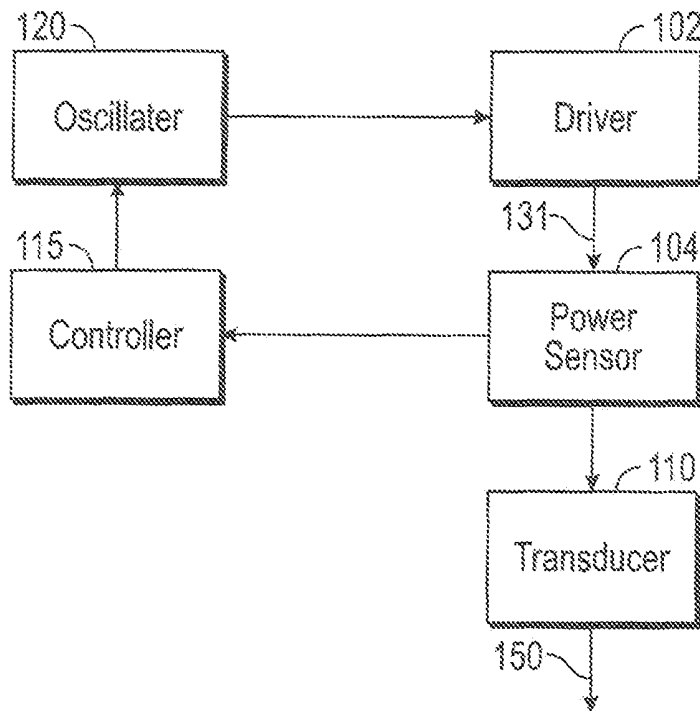

FIG. 4

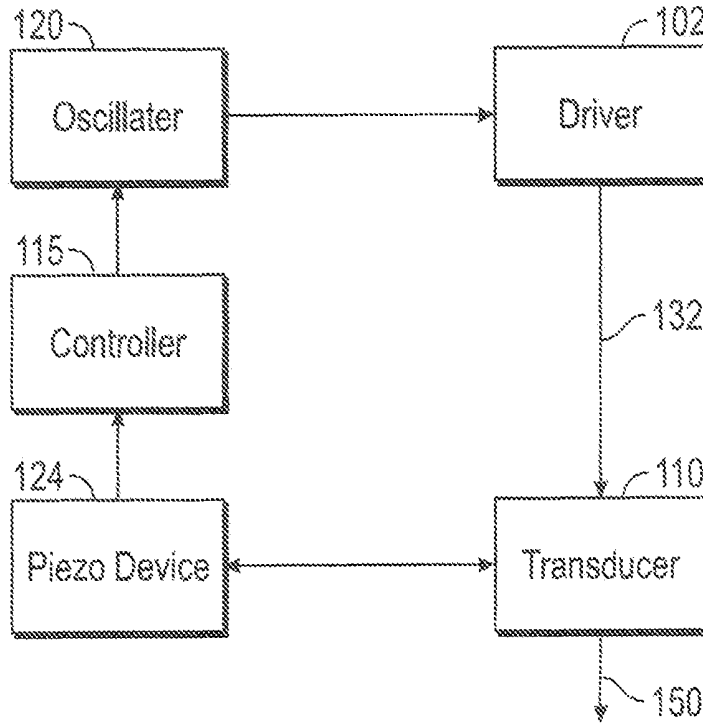

FIG. 5

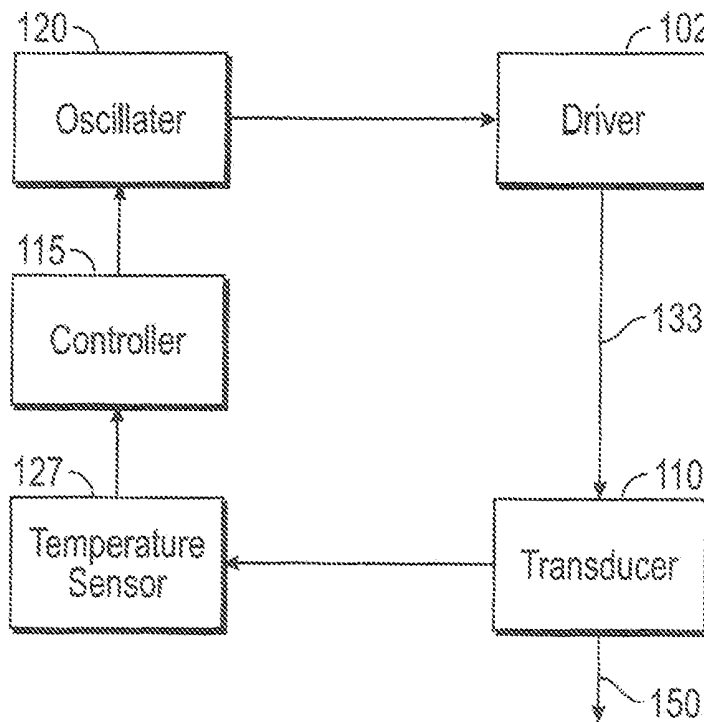

FIG. 6

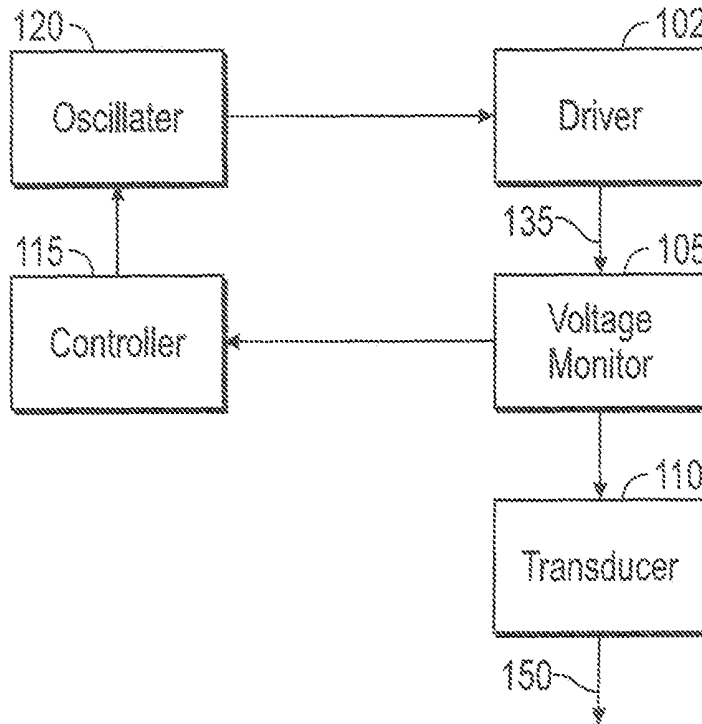

FIG. 7

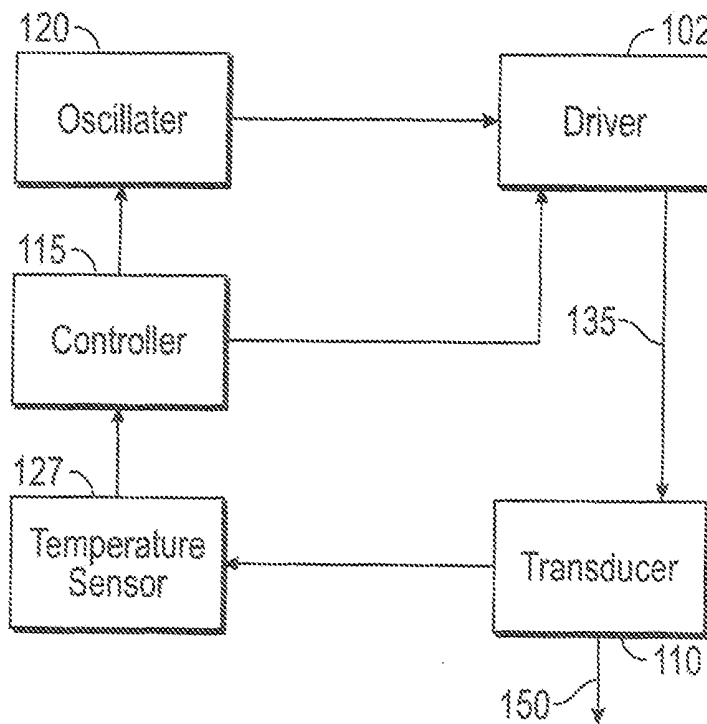

FIG. 8

1

SYSTEMS AND METHODS FOR MONITORING AND CONTROLLING ULTRASOUND POWER OUTPUT AND STABILITY

CROSS-REFERENCE TO RELATED APPLICATIONS

This application claims priority to and the benefit of U.S. Provisional Patent Application Ser. No. 61/506,609, entitled "Systems and Methods for Monitoring Ultrasound Power Efficiency," filed Jul. 11, 2011; and U.S. Provisional Patent Application Ser. No. 61/506,610, entitled "Methods and Systems for Controlling Acoustic Energy Deposition into a Medium," filed Jul. 11, 2011; all of which are incorporated by reference herein.

BACKGROUND

Temperatures change in a treatment device under operate can affect the stability of the device. Cooling the device may help stability, however, cooling device are bulky and require additional energy to operate. Accordingly, new approaches to monitoring ultrasound energy that is transmitted into a region of interest are needed.

SUMMARY

Various embodiments described herein provide methods and systems for monitoring ultrasound energy. Some embodiments provide a method of providing ultrasound energy having a stable power output. The method can comprise providing ultrasound energy from a ultrasound transducer; determining a power level threshold of the ultrasound energy; monitoring a power level of the ultrasound energy over time of the ultrasound energy; communicating a power level to a controller; adjusting the frequency of the ultrasound energy upon a change in the power level; and maintaining the power level threshold of the ultrasound energy.

In some embodiments, the method can further comprise emitting the ultrasound energy at a specific frequency and correcting the frequency to the specific frequency upon a change in the power level. In some embodiments, the method can comprise changing power provided to a transducer providing the ultrasound energy based on the adjusting the frequency of the ultrasound energy. In some embodiments, the method can comprise terminating the providing the ultrasound energy upon a change of the power level above the power level threshold.

Some embodiments provide a method of providing ultrasound energy having a stable power output. The method can comprise providing ultrasound energy from an ultrasound transducer; determining a power level threshold of the ultrasound energy; monitoring a temperature of the ultrasound transducer over time; communicating the temperature to a controller; adjusting the frequency of the ultrasound energy upon a change in the temperature; and maintaining the power level threshold of the ultrasound energy.

DRAWINGS

The present disclosure will become more fully understood from the description and the accompanying drawings, wherein:

FIG. 1 is a cross sectional view illustrating tissue layers and ultrasound energy directed to a portion of the tissue layers, in accordance with various non-limiting embodiments;

2

FIG. 2 is a graph illustrating ultrasound efficiency at a frequency, in accordance with various non-limiting embodiments;

FIG. 3 is a graph illustrating ultrasound efficiency a frequency, in accordance with various nonlimiting embodiments;

FIG. 4 is a block diagram illustrating a system in accordance with various non-limiting embodiments;

FIG. 5 is a block diagram illustrating a system in accordance with various non-limiting embodiments;

FIG. 6 is a block diagram illustrating a system in accordance with various non-limiting embodiments.

FIG. 7 is a block diagram illustrating a system in accordance with various non-limiting embodiments; and

FIG. 8 is a block diagram illustrating a system in accordance with various non-limiting embodiments.

DESCRIPTION

The following description is merely exemplary in nature and is in no way intended to limit the various embodiments, their application, or uses. As used herein, the phrase "at least one of A, B, and C" should be construed to mean a logical (A or B or C), using a non-exclusive logical "or." As used herein, the phrase "A, B and/or C" should be construed to mean (A, B, and C) or alternatively (A or B or C), using a non-exclusive logical "or." It should be understood that steps within a method may be executed in different order without altering the principles of the present disclosure.

The drawings described herein are for illustrative purposes only of selected non-limiting embodiments and not all possible implementations, and are not intended to limit the scope of any of the various embodiments disclosed herein or any equivalents thereof. It is understood that the drawings are not drawn to scale. For purposes of clarity, the same reference numbers will be used in the drawings to identify similar elements.

The various embodiments may be described herein in terms of various functional components and processing steps. It should be appreciated that such components and steps may be realized by any number of hardware components configured to perform the specified functions. For example, various embodiments may employ various medical treatment devices, visual imaging and display devices, input terminals and the like, which may carry out a variety of functions under the control of one or more control systems or other control devices. In addition, the embodiments may be practiced in any number of medical contexts and that the various embodiments relating to a method and system for acoustic energy deposition in tissue, as described herein, are merely indicative of one of the many applications for the invention. For example, the principles, features and methods discussed may be applied to any medical application. Further, various aspects of the various embodiments may be suitably applied to cosmetic applications. Moreover, some of the embodiments may be applied to cosmetic enhancement of skin and/or various soft tissue layers.

Various embodiments provide methods and systems to adjust a temperature of a transducer, in order to maintain maximum efficiency of power applied by the transducer. Some embodiments provide methods and systems to minimize or eliminate temperature saturation of a transducer during the delivery of power to the transducer. In some embodiments, methods and systems can control a temperature of a transducer to maintain a desired frequency of energy transmission at a maximum power.

ducer and terminating the providing ultrasound energy when the temperature of the ultrasound transducer is above the temperature threshold.

In some embodiments, the method can further comprise emitting the ultrasound energy at a specific frequency and correcting the frequency to the specific frequency upon the change of voltage. In some embodiments, the method can comprise terminating the providing the ultrasound energy upon a change of the power level above the power level threshold.

In some embodiments, temperature can be monitored by monitoring changes in time of flight of the ultrasound energy from the transducer. In some embodiments, temperature can be monitored by a piezoelectric sensor that may be a portion of transducer, as described herein. In various embodiments, a controller may use a look up table to change a parameter. In some embodiments, controller can employ hardware, software, or a combination of both to change a parameter such as power, voltage or current.

With reference to FIG. 1, a cross sectional view of tissue layers and ultrasound energy directed to at least one of the tissue layers, according to various embodiments of the present invention, is illustrated. The tissue layers illustrated are skin surface **204**, epidermal layer **202**, dermis layer **206**, fat layer **208**, SMAS layer **210**, and muscle and connective tissue layer **212**. Ultrasound probe **205** transmits ultrasound energy **220** transmitting in ROI **215**. In various embodiments, ultrasound probe **205** is capable of transmitting ultrasound energy **220** transmitting at variable depths in ROI **215**, such as, for example, the depths described herein. Ultrasound probe **205** is capable of transmitting therapeutic ultrasound energy as a single frequency, variable frequencies, or a plurality of frequencies, such as, for example, within the frequency ranges described herein. Ultrasound probe **205** is capable of transmitting ultrasound energy **220** transmitting for variable time periods or to pulse the transmission over time, such as, for example, those time intervals described herein. Ultrasound probe **205** is capable of providing various energy levels of therapeutic ultrasound energy, such as, for example, the energy levels described herein.

Ultrasound probe **205** may be individual hand-held device, or may be part of a treatment system or part of cosmetic enhancement system. The ultrasound probe **205** can provide both therapeutic ultrasound energy and imaging ultrasound energy. However, ultrasound probe **205** may provide only therapeutic ultrasound energy. Ultrasound probe **205** may comprise a therapeutic transducer and a separate imaging transducer. Ultrasound probe **205** may comprise a transducer or a transducer array capable of both therapeutic and imaging applications. According an alternative embodiment, ultrasound probe **205** is coupled directly to one of the tissue layers, as opposed to skin surface **204** to treat the tissue layer. For example, ultrasound probe **205** can be integrated to or attached to a tool, such as, for example, an arthroscopic tool, laparoscopic tool, or an endoscopic tool that may be inserted into a patient's body with minimal invasiveness.

In various embodiments, the ultrasound energy level is in a range of about 0.1 joules to about 500 joules in order to create an ablative lesion. However, the ultrasound energy **108** level can be in a range of from about 0.1 joules to about 100 joules, or from about 1 joules to about 50 joules, or from about 0.1 joules to about 10 joules, or from about 50 joules to about 100 joules, or from about 100 joules to about 500 joules, or from about 50 joules to about 250 joules.

Further, the amount of time ultrasound energy is applied at these levels varies in the range from approximately 1 millisecond to several minutes. However, a range can be from

about 1 millisecond to about 5 minutes, or from about 1 millisecond to about 1 minute, or from about 1 millisecond to about 30 seconds, or from about 1 millisecond to about 10 seconds, or from about 1 millisecond to about 1 second, or from about millisecond to about 0.1 seconds, or about 0.1 seconds to about 10 seconds, or about 0.1 seconds to about 1 second, or from about 1 millisecond to about 200 milliseconds, or from about 1 millisecond to about 0.5 seconds.

The frequency of the ultrasound energy can be in a range from about 0.1 MHz to about 100 MHz, or from about 0.1 MHz to about 50 MHz, or from about 1 MHz to about 50 MHz or about 0.1 MHz to about 30 MHz, or from about 10 MHz to about 30 MHz, or from about 0.1 MHz to about 20 MHz, or from about 1 MHz to about 20 MHz, or from about 20 MHz to about 30 MHz.

The frequency of the ultrasound energy can be in a range from about 1 MHz to about 12 MHz, or from about 5 MHz to about 15 MHz, or from about 2 MHz to about 12 MHz or from about 3 MHz to about 7 MHz.

In some embodiments, the ultrasound energy can be transmitted to depths at or below a skin surface in a range from about 0 mm to about 150 mm, or from about 0 mm to about 100 mm, or from about 0 mm to about 50 mm, or from about 0 mm to about 30 mm, or from about 0 mm to about 20 mm, or from about 0 mm to about 10 mm, or from about 0 mm to about 5 mm. In some embodiments, the ultrasound energy can be transmitted to depths below a skin surface in a range from about 5 mm to about 150 mm, or from about 5 mm to about 100 mm, or from about 5 mm to about 50 mm, or from about 5 mm to about 30 mm, or from about 5 mm to about 20 mm, or from about 5 mm to about 10 mm. In some embodiments, the ultrasound energy can be transmitted to depths below a skin surface in a range from about 10 mm to about 150 mm, or from about 10 mm to about 100 mm, or from about 10 mm to about 50 mm, or from about 10 mm to about 30 mm, or from about 10 mm to about 20 mm, or from about 0 mm to about 10 mm.

In some embodiments, the ultrasound energy can be transmitted to depths at or below a skin surface in the range from about 20 mm to about 150 mm, or from about 20 mm to about 100 mm, or from about 20 mm to about 50 mm, or from about 20 mm to about 30 mm. In some embodiments, the ultrasound energy can be transmitted to depths at below a skin surface in a range from about 30 mm to about 150 mm, or from about 30 mm to about 100 mm, or from about 30 mm to about 50 mm. In some embodiments, the ultrasound energy can be transmitted to depths at or below a skin surface in a range from about 50 mm to about 150 mm, or from about 50 mm to about 100 mm. In some embodiments, the ultrasound energy can be transmitted to depths at or below a skin surface in a range from about 20 mm to about 60 mm, or from about 40 mm to about 80 mm, or from about 10 mm to about 40 mm, or from about 5 mm to about 40 mm, or from about 0 mm to about 40 mm, or from about 10 mm to about 30 mm, or from about 5 mm to about 30 mm, or from about 0 mm to about 30 mm.

In various embodiments, a temperature of tissue receiving the ultrasound energy can be in a range from 30° C. to about 100° C., or from 43° C. to about 60° C., or from 50° C. to about 70° C., or from 30° C.; to about 50° C., or from 43° C. to about 100° C., or from 33° C. to about 100° C., or from 30° C. to about 65° C., or from 33° C. to about 70° C., as well as variations thereof.

Also, depending at least in part upon a specific biological effect and the tissue layers that are targeted, temperature of tissue receiving the ultrasound energy within ROI **215** may change in a range from approximately 10° C. to about 15° C. In various embodiments, a temperature of tissue receiving the

ultrasound energy is raised to a temperature in a range from about 40° C. to about 55° C., or from about 43° C. to about 48° C., or below a threshold of ablation of the tissue.

Moving to FIG. 2, a graph illustrates efficiency of an ultrasound transducer at specific frequency f_c , in accordance with various embodiments. Efficiency of a transducer is defined as the ratio of the power output in the desired form to the total power input. Mathematically, if P_{in} represents the total power input and P_{out} represents the power output in the desired form, then the efficiency E, as a ratio between 0 and 1, is given by:

$$E = P_{out} / P_{in} \quad \text{Equation 1}$$

If E % represents the efficiency as a percentage, then:

$$E \% = 100 P_{out} / P_{in} \quad \text{Equation 2}$$

In general, a transducer is not 100% efficient and power is typically lost during the operation of the transducer in the form of heat. However, for a high-Q transducer, efficiency can approach 100% and heat generated by the transducer is minimized. A transducer is most efficient at specific frequency f_c , as illustrated in FIG. 2. The transducer has the maximum power output at frequency f_c .

When a transducer operates, the transducer heats up over time and the temperature of the transducer changes. As the temperature of the transducer changes, the resonant frequency will shift towards frequency f_r , as illustrated in FIG. 3. This frequency shift decreases the efficiency of the transducer and, the power output from the transducer is significantly lower in the example of FIG. 3 as compared to the example of FIG. 2.

Transducer efficiency decreases due to changes in temperature of the transducer as a function of time. In addition, a change in temperature of the transducer will cause a frequency shift. The frequency shift changes as a function of increasing temperature of the transducer. A frequency shift decreases efficiency and can cause a system to change total power input to make up for a loss of power applied by the transducer. A frequency shift will change the impedance of the transducer.

In various embodiments, systems and methods, described herein, monitor transducer temperature and report changes in temperature to a controller to modify the frequency generation to the transducer. In various embodiments, systems and methods can monitor transducer temperature and report changes in temperature to a controller to modify the total power input to the transducer. In various embodiments, systems and methods can monitor efficiency and controls transducer temperature to prevent energy transmission from a shift in frequency.

In various embodiments, systems and methods can at least one of monitor transducer temperature and control transducer temperature. In various embodiments, systems and methods can operate the transducer to at or near maximum efficiency of power over a period of time. In various embodiments, systems and methods can operate the transducer to at or near maximum efficiency of power as a temperature of the transducer changes. In various embodiments, systems and methods can modify temperature of the transducer to maintain operation at or near maximum efficiency of power. In various embodiments, systems and methods can prevent a change in impedance of the transducer.

In some embodiments, energy emission, such as, an ultrasound emission, can be directed to targeted tissue to initiate a desired treatment to the targeted tissue. If the power of the energy emission, such as, an ultrasound emission, is too high, the targeted tissue can be permanently damaged, which provide pain to the patient being treated. In addition, if the power

of the energy emission such as, an ultrasound emission, is too high, the desired treatment to the targeted tissue may not be effective. If the power of the energy emission, such as, an ultrasound emission, is too low, the desired treatment to the targeted tissue may not be effective.

If the efficiency of the transducer degrades, the power of energy emission decreases. If the temperature of the transducer changes, the efficiency of the transducer changes and the power of energy emission decreases. For the most effective treatment to targeted tissue, power of energy emission is constant. Various embodiments provide methods and systems to provide constant energy emission from transducer 110 that is directed to targeted tissue.

Referring to FIG. 4, system 131 is illustrated, in accordance with some embodiments. System 131 can comprise drivers 102, power sensor 104, transducer 110, controller 115, and oscillator 120. In various embodiments, oscillator 120 generates a frequency which is communicated to drivers 102 to power transducer 110 to produce energy transmission 150 at the frequency. Oscillator 120 can be an oscillator or any frequency generator, now known or later developed. For example, oscillator 120 can be but is not limited to, a function generator, a frequency generator, a waveform generator, a signal generator, pitch generator, a wave generator, or a pulse generator, frequency synthesizer, direct digital synthesizer, or combinations thereof. In some embodiments, oscillator 120 can be combined with or integrated to drivers 102. In some embodiments, oscillator 120 is programmable. In some embodiments, controller 115 can be combined with or integrated to at least one of oscillator 120 and drivers 102. In some embodiments, power sensor 104 can be combined with or integrated to at least one of oscillator 120, controller 115 and drivers 102. In some embodiments, power sensor 104 can be combined with or integrated to at least one of oscillator 120, and drivers 102. In some embodiments, power sensor 104 can be combined with or integrated to at least one of controller 115 and drivers 102. In some embodiments, power sensor 104 can be combined with or integrated to at least one of oscillator 120, and controller 115. In some embodiments, power sensor 104 can be combined with or integrated to drivers 102. In some embodiments, power sensor 104 can be combined with or integrated to oscillator 120. In some embodiments, power sensor 104 can be combined with or integrated to controller 115.

In some embodiments, power sensor 104 monitors power input from drivers 102 to transducer 110. In some embodiments, power sensor 104 communicates with controller 115, which controls oscillator 120. In some embodiments, controller 115 receives signal from power sensor 104 and controls a frequency generated by oscillator 120 based on the received signal. In some embodiments, power sensor 104 communicates a power level of the power input from drivers 102.

As transducer 110 efficiency of energy transmission 150 degrades, for example as illustrated in FIG. 3, drivers 102 changes the power input to transducer 110. In some embodiments, power sensor 104 detects the change in power input to transducer 110 and communicates with controller 115, which controls oscillator 120 to change in the power level of the power input from supply and/or drivers 102. In some embodiments, oscillator 120 generates a correction to the frequency which is communicated to the drivers 102, which is based on the communication from the power sensor 104. In some embodiments, the correction to the frequency lowers the power level of power input from drivers 102. In some embodiments, energy transmission 150 is corrected to specific frequency f_c as illustrated in FIG. 2. If this correction to specific frequency f_c does not lower the power input from the drivers

102 to transducer 110 below a threshold, power sensor 104 communicates this elevated power level to controller 115, which controls oscillator 120 for another generation of a correction to the frequency. In some embodiments, system 131 comprises a shut off power function, which is initiated if power sensor 104 detects a power level that is above a predetermined threshold, in some embodiments, the shut off power function prevents the damaging or destroying of transducer 110.

In some embodiments, the thickness of the transduction element of transducer 110 may be configured to be uniform. That is, the transduction element may be configured to have a thickness that is generally substantially the same throughout. In another exemplary embodiment, the transduction element may also be configured with a variable thickness, and/or as a multiple damped device. For example, the transduction element of transducer 110 may be configured to have a first thickness selected to provide a specific operating frequency of a lower range, for example from approximately 1 kHz to 3 MHz. The transduction element may also be configured with a second thickness selected to provide a specific operating frequency of a higher range, for example from approximately 3 to 100 MHz or other frequency ranges described herein.

In yet another exemplary embodiment, transducer 110 may be configured as a single broadband transducer excited with two or more frequencies to provide an adequate output for raising the temperature within ROI 215 to the desired level. Transducer 110 may also be configured as two or more individual transducers, wherein each transducer 110 may comprise a transduction element. The thickness of the transduction elements may be configured to provide specific-operating frequencies in a desired treatment range. For example, in some embodiments, transducer 110 may comprise a first transducer 110 configured with a first transduction element having a thickness corresponding to a specific frequency range of approximately 1 MHz to 3 MHz, and a second transducer 110 configured with a second transduction element having a thickness corresponding to a specific frequency of approximately 3 MHz to 100 MHz or frequency ranges described herein.

Moreover, in some embodiments, any variety of mechanical lenses or variable focus lenses, e.g. liquid-filled lenses, may also be used to focus and or defocus the energy field. For example, transducer 110 may also be configured with an electronic focusing array in combination with one or more transduction elements to facilitate changed flexibility in treating ROI 215. Array may be configured in a manner similar to transducer 110. That is, array may be configured as an array of electronic apertures that may be operated by a variety of phases via variable electronic time delays. Accordingly, the electronic apertures of array may be manipulated, driven, used, configured to produce and/or deliver energy in a manner corresponding to the phase variation caused by the electronic time delay. For example, these phase variations may be used to deliver defocused beams, planar beams, and/or focused beams, each of which may be used in combination to achieve different physiological effects in ROI 215.

Transduction elements may be configured to be concave, convex, and/or planar. For example, transduction elements can be configured to be concave in order to provide focused energy for treatment of ROI 215. In another exemplary embodiment, transduction elements may be configured to be substantially flat in order to provide substantially uniform energy to ROI 215. In addition, transduction elements may be configured to be any combination of concave, convex, and/or substantially flat structures. For example, a first transduction

element may be configured to be concave, while a second transduction element may be configured to be substantially flat.

Moreover, transduction element can be any distance from the skin surface 204. In that regard, it can be far away from the skin surface 204 disposed within a long transducer 110 or it can be just a few millimeters from skin surface 204. In certain exemplary embodiments, positioning the transduction element closer to skin surface 204 is better for transmitting ultrasound at high frequencies. Moreover, both two and three dimensional arrays of transduction elements can be used in various embodiments.

In some embodiments, transducer 110 may also be configured as an annular array to provide planar, focused and/or defocused acoustical energy. For example, in some embodiments, an annular array may comprise a plurality of rings. Rings may be mechanically and electrically isolated into a set of individual elements, and may create planar, focused, or defocused waves. For example, such waves can be specified on-axis, such as by methods of adjusting corresponding phase delays. An electronic focus may be moved along various depth positions in ROI 215, and may enable variable strength or beam tightness, while an electronic defocus may have varying amounts of defocusing. In some embodiments, a lens and/or convex or concave shaped annular array may also be provided to aid focusing or defocusing such that any time differential delays can be reduced. Movement of annular array in one, two or three-dimensions, or along any path, such as through use of probes, motion mechanisms, any conventional robotic arm mechanisms, and the like may be implemented to scan and/or treat a volume or any corresponding space within ROI 215.

In FIG. 5, system 132 is illustrated, in accordance with some embodiments. System 132 can comprise drivers 102, transducer 110, piezoelectric sensor 124, controller 115, and oscillator 120. In some embodiments, piezoelectric sensor 124 can be combined with or integrated to at least one of oscillator 120 and drivers 102. In some embodiments, piezoelectric sensor 124 can be combined with or integrated into oscillator 120 in some embodiments, piezoelectric sensor 124 can be combined with into integrated to drivers 102. In various embodiments, oscillator 120 generates a frequency which is communicated to drivers 102 to power transducer 110 to produce energy transmission 150 at the frequency. In some embodiments, piezoelectric sensor 124 monitors heat generated by transducer 110. In some embodiments, piezoelectric sensor 124 is coupled to transducer 110. In some embodiments, piezoelectric sensor 124 is integrated to transducer 110. For example, piezoelectric sensor 124 may be a portion of transducer 110, which that is isolated or insulation from the rest of transducer 110, and may comprise identical materials as transducer 110. However, in one aspect of this example, piezoelectric sensor 124 has the opposite temperature coefficient of transducer (same coefficient but opposite sign) and the piezoelectric sensor 124 changes temperature at the same rate as transducer 110, thus compensating for changes in temperature of transducer 110.

Piezoelectric sensor 124 can comprise ceramic, or any other material or combination of material described herein. In some embodiments, piezoelectric sensor 124 is configured with a temperature coefficient that is lower than the temperature coefficient of transducer 110. In some embodiments, piezoelectric sensor 124 is configured with temperature coefficient, which is negative. In various embodiments, piezoelectric sensor 124 generates an electric potential in response to a temperature change, and communicates this electric potential to controller 115, which controls oscillator 120. In some

embodiments, piezoelectric sensor 124 communicates with oscillator 120. In some embodiments, controller 115 receives signal from piezoelectric sensor 124 and controls a frequency generated by oscillator 120 based on the received signal. In some embodiments, piezoelectric sensor 124 communicates the heat generated by transducer 110, which can be communicated using temperature.

As transducer 110 efficiency of energy transmission 150 degrades, for example as illustrated in FIG. 3, heat generated by transducer 110 changes. For example, drivers 102 changes the power input to transducer 110, which can change the heat generated by transducer 110. In some embodiments, piezoelectric sensor 124 detects the change in heat generation by transducer 110 and communicates with controller 115, which controls oscillator 120, the change in heat generation, in some embodiments, oscillator 120 generates a correction to the frequency which is communicated to the drivers 102, which is based on the communication from the piezoelectric device 124. In some embodiments, the correction to the frequency lowers the power level of power input from drivers 102, which can lower the amount of heat that is generated by transducer 110. In some embodiments, the correction to the frequency lowers the power level of power input from drivers 102. In some embodiments, energy transmission 150 is corrected to specific frequency f_c as illustrated in FIG. 2. If this correction to specific frequency f_c does not lower the power input from the drivers 102 to transducer 110 below a threshold, piezoelectric sensor 124 communicates this elevated heat generation by transducer 110 to oscillator 124 for another generation of a correction to the frequency. In some embodiments, system 132 comprises a shut off power function, which is initiated if piezoelectric sensor 124 detects a heat generation level or a temperature of transducer 110 is above a predetermined threshold. In some embodiments, the shut off power function prevents the damaging or destroying of transducer 110.

Turning to FIG. 6, system 133 is illustrated, in accordance with some embodiments. System 133 can comprise drivers 102, transducer 110, temperature sensor 127, and oscillator 120. In some embodiments, temperature sensor 127 can be combined with or integrated to at least one of oscillator 120 and drivers 102. In various embodiments, oscillator 120 generates a frequency which is communicated to drivers 102 to power transducer 110 to produce energy transmission 150 at the frequency, in some embodiments, temperature sensor 127 monitors temperature of transducer 110. In some embodiments, temperature sensor 127 coupled to transducer 110, in some embodiments, temperature sensor 127 is integrated to transducer 110. Temperature sensor 127 can be any suitable temperature sensor, now known or later developed. In some embodiments, temperature sensor 127 communicates with controller 115, which communicates with oscillator 120. In some embodiments, temperature sensor 127 communicates with oscillator 120. In some embodiments, controller 115 receives signal from temperature sensor 127 and controls a frequency generated by oscillator 120 based on the received signal. In some embodiments, temperature sensor 127 communicates the temperature of by transducer 110.

As transducer 110 efficiency of energy transmission 150 degrades, for example as illustrated in FIG. 3, heat generated by transducer 110 changes. For example, drivers 102 changes the power input to transducer 110, which can change the heat generated by transducer 110. In some embodiments, temperature sensor 127 detects the change in heat generation by transducer 110 and communicates with controller 115, which controls oscillator 120, the change in heat generation. In some embodiments, oscillator 120 generates a correction to the frequency which is communicated to the drivers 102, which is

based on the communication from the piezoelectric device 124. In some embodiments, the correction to the frequency lowers the power level of power input from drivers 102, which can lower the amount of heat that is generated by transducer 110. In some embodiments, the correction to the frequency lowers the power level of power input from drivers 102. In some embodiments, energy transmission 150 is corrected to specific frequency f_c as illustrated in FIG. 2. If this correction to specific frequency f_c does not lower the power input from the drivers 102 to transducer 110 below a threshold, temperature sensor 127 communicates this elevated heat generation by transducer 110 to oscillator 124 for another generation of a correction to the frequency. In some embodiments, system 132 comprises a shut off power function, which is initiated if temperature sensor 127 detects a heat generation level or a temperature of transducer 110 is above a predetermined threshold. In some embodiments, the shut off power function prevents the damaging or destroying of transducer 110.

Moving to FIG. 7, system 135 is illustrated, in accordance with some embodiments. System 135 can comprise drivers 102, voltage monitor 105, transducer 110, controller 115, and oscillator 120. In various embodiments, oscillator 120 generates a frequency which is communicated to drivers 102 to power transducer 110 to produce energy transmission 150 at the frequency. Oscillator 120 can be an oscillator or any frequency generator, now known or later developed. For example, oscillator 120 can be but is not limited to, a function generator, a frequency generator, a waveform generator, a signal generator, pitch generator, a wave generator, or a pulse generator, frequency synthesizer, direct digital synthesizer, or combinations thereof. In some embodiments, oscillator 120 can be combined with or integrated to drivers 102. In some embodiments, oscillator 120 is programmable. In some embodiments, controller 115 can be combined with or integrated to at least one of oscillator 120 and drivers 102. In some embodiments, voltage monitor 105 can be combined with or integrated to at least one of oscillator 120, controller 115 and drivers 102. In some embodiments, voltage monitor 105 can be combined with or integrated to at least one of oscillator 120, and drivers 102. In some embodiments, voltage monitor 105 can be combined with or integrated to at least one of controller 115 and drivers 102. In some embodiments, voltage monitor 105 can be combined with or integrated to at least one of oscillator 120, and controller 115. In some embodiments, voltage monitor 105 can be combined with or integrated to drivers 102. In some embodiments, voltage monitor 105 can be combined with or integrated to oscillator 120. In some embodiments, voltage monitor 105 can be combined with or integrated to controller 115. In some embodiments, voltage monitor 105 monitors voltage of power from drivers 102 to transducer 110. In some embodiments, voltage monitor 105 communicates with controller 115, which controls oscillator 120. In some embodiments, controller 115 receives signal from voltage monitor 105 and controls a frequency generated by oscillator 120 based on the received signal, in some embodiments, voltage monitor 105 communicates a voltage level of the voltage of power from drivers 102.

As transducer 110 efficiency of energy transmission 150 degrades, for example as illustrated in FIG. 3, drivers 102 changes the voltage of power to transducer 110. In some embodiments, voltage monitor 105 detects the increase in voltage of power to transducer 110 and communicates with controller 115, which controls oscillator 120 to change in the voltage level of the voltage of power from supply and/or drivers 102. In some embodiments, oscillator 120 generates a correction to the frequency which is communicated to the drivers 102, which is based on the communication from the

voltage monitor **105**. In some embodiments, the correction to the frequency lowers the voltage level of voltage of power from drivers **102**. In some embodiments, energy transmission **150** is corrected to specific frequency f_c as illustrated in FIG. 2. If this correction to specific frequency f_c does not lower the voltage of power from the drivers **102** to transducer **110** below a threshold, voltage monitor **105** communicates this elevated voltage level to controller **115**, which controls oscillator **120** for another generation of a correction to the frequency. In some embodiments, system **135** comprises a shut off power function, which is initiated if voltage monitor **105** detects a voltage level that is above a predetermined threshold. In some embodiments, the shut off power function prevents the damaging or destroying of transducer **110**.

FIG. 8 With reference to FIG. 8, system **135** is illustrated, in accordance with some embodiments. System **135** can comprise drivers **102**, transducer **110**, temperature sensor **127**, and oscillator **120**. In some embodiments, temperature sensor **127** is integrated with or integrated to at least one of oscillator **120** and drivers **102**. In various embodiments, oscillator **120** generates a frequency which is communicated to drivers **102** to power transducer **110** to produce energy transmission **150** at the frequency. In some embodiments, temperature sensor **127** monitors temperature of transducer **110**. In some embodiments, temperature sensor **127** coupled to transducer **110**. In some embodiments, temperature sensor **127** is integrated to transducer **110**. Temperature sensor **127** can be any suitable temperature sensor, now known or later developed. In some embodiments, temperature sensor **127** communicates with controller **115**, which communicates with oscillator **120**. In some embodiments, temperature sensor **127** communicates with oscillator **120**. In some embodiments, controller **115** receives signal from temperature sensor **127** and controls a frequency generated by oscillator **120** based on the received signal. In some embodiments, temperature sensor **127** communicates the temperature of by transducer **110**. As transducer **110** efficiency of energy transmission **150** degrades, for example as illustrated in FIG. 3, drivers **102** changes the power to transducer **110**, which change the voltage across the transducer **110**. In some embodiments, controller **115** detects the change in voltage across transducer **110** and communicates with controller **115**. In some embodiments, oscillator **120** generates a correction to the frequency which is communicated to the drivers **102**, which is based on the communication from controller **115**. In some embodiments, the correction to the frequency lowers the voltage level of voltage across transducer **110**, in some embodiments, energy transmission **150** is corrected to specific frequency f_c as illustrated in FIG. 2. If this correction to specific frequency f_c does not lower the voltage across transducer **110** below a threshold, controller **115** communicates this elevated voltage level to oscillator **120** for another generation of a correction to the frequency.

As transducer **110** efficiency of energy transmission **150** degrades, for example as illustrated in FIG. 3, heat generated by transducer **110** changes. For example, drivers **102** changes the power input to transducer **110** which can change the heat generated by transducer **110**. In some embodiments, temperature sensor **127** detects the change in heat generation by transducer **110** and communicates with controller **115**, which controls oscillator **120**, the change in heat generation. In some embodiments, oscillator **120** generates a correction to the frequency which is communicated to the drivers **102**, which is based on the communication from the piezoelectric device **124**. In some embodiments, the correction to the frequency lowers the power level of power input from drivers **102**, which can lower the amount of heat that is generated by transducer

110. In some embodiments, the correction to the frequency lowers the power level of power input from drivers **102**. In some embodiments, energy transmission **150** is corrected to specific frequency f_c as illustrated in FIG. 2. If this correction to specific frequency f_c does not lower the power input from the drivers **102** to transducer **110** below a threshold, temperature sensor **127** communicates this elevated heat generation by transducer **110** to oscillator **124** for another generation of a correction to the frequency. In some embodiments, system **132** comprises a shut off power function, which is initiated if temperature sensor **127** detects a heat generation level or a temperature of transducer **110** is above a predetermined threshold. In some embodiments, the shut off power function prevents the damaging or destroying of transducer **110**.

The following patents and patent applications are incorporated by reference: US Patent Application Publication No. 20050256406, entitled "Method and System for Controlled Scanning, Imaging, and/or Therapy" published Nov. 17, 2005; US Patent Application Publication No. 20060058664, entitled "System and Method for Variable Depth Ultrasound Treatment" published Mar. 16, 2006; US Patent Application Publication No. 20060084891, entitled "Method and System for Ultra-High Frequency Ultrasound Treatment" published Apr. 20, 2006; U.S. Pat. No. 7,530,958, entitled "Method and System for Combined Ultrasound Treatment" issued May 12, 2009; US Patent Application Publication No. 2008071255, entitled "Method and System for Treating Muscle, Tendon, Ligament, and Cartilage Tissue" published Mar. 20, 2008; U.S. Pat. No. 6,623,430, entitled "Method and Apparatus for Safely Delivering Medicants to a Region of Tissue Using Imaging, Therapy, and Temperature Monitoring Ultrasonic System," issued Sep. 23, 2003; U.S. Pat. No. 7,571,336, entitled "Method and System for Enhancing Safety with Medical Peripheral Device by Monitoring if Host Computer is AC Powered" issued Aug. 4, 2009; US Patent Application Publication No. 20080281255, entitled "Methods and Systems for Modulating Medicants Using Acoustic Energy" published Nov. 13, 2008; US Patent Application Publication No. 20060116671, entitled "Method and System for Controlled Thermal Injury of Human Superficial Tissue," published Jun. 1, 2006; US Patent Application Publication No. 2006011744, entitled "Method and System for Treatment of Sweat Glands," published May 25, 2006; US Patent Application Publication No. 20080294073, entitled "Method and System for Non-Ablative Acne Treatment and Prevention," published Oct. 8, 2009; U.S. Pat. No. 8,133,180, entitled "Method and System for Treating Cellulite," issued Mar. 13, 2012; U.S. Pat. No. 8,066,641, entitled "Method and System for Photoaged Tissue," issued Nov. 29, 2011; U.S. Pat. No. 7,491,171, entitled "Method and System for Treating Acne and Sebaceous Glands," issued Feb. 17, 2009; U.S. Pat. No. 7,615,016, entitled "Method and System for Treating Stretch Marks," issued Nov. 10, 2009; and U.S. Pat. No. 7,530,356, entitled "Method and System for Noninvasive Mastopexy," issued May 12, 2009.

It is believed that the disclosure set forth above encompasses at least one distinct invention with independent utility. While the invention has been disclosed herein, the specific embodiments thereof as disclosed and illustrated herein are not to be considered in a limiting sense as numerous variations are possible. The subject matter of the inventions includes all novel and non-obvious combinations and sub combinations of the various elements, features, functions and/or properties disclosed herein.

Various embodiments and the examples described herein are not intended to be limiting in describing the full scope of systems and methods of this invention. Equivalent changes,

modifications and variations of various embodiments, materials, systems, and methods may be made within the scope of the present invention, with substantially similar results.

The invention claimed is:

1. A method of providing ultrasound energy having a stable power output, the method comprising:
 - emitting ultrasound energy from an ultrasound transducer at a specific frequency and at a predetermined power level;
 - monitoring a power level of the ultrasound energy over a time;
 - communicating the power level to a controller;
 - correcting a frequency of the ultrasound energy to the specific frequency upon the power level deviating for the predetermined, power level;
 - monitoring a temperature of the ultrasound transducer over the time of the emitting ultrasound energy;
 - communicating the temperature of the ultrasound transducer to the controller; and
 - correcting the frequency of the ultrasound energy to the specific frequency upon a change in the temperature of the ultrasound transducer, wherein the change of temperature is outside a predetermined temperature range; thereby maximizing efficiency of the ultrasound transducer emitting the ultrasound energy.
2. The method according to claim 1 further comprising monitoring a voltage of power driving the ultrasound transducer over time;
- communicating the voltage to the controller; and
- correcting the frequency to the specific frequency upon a change of voltage of the power driving the ultrasound transducer.
3. The method according to claim further comprising terminating the emitting ultrasound energy upon a change of the power level above a predetermined power level threshold.
4. The method according to claim 1 further comprising terminating the emitting ultrasound energy when the temperature of the ultrasound transducer is above a predetermined temperature threshold.
5. The method according to claim 1 further comprising terminating the emitting ultrasound energy when the temperature of the ultrasound transducer is below a predetermined temperature threshold.
6. The method according to claim 1 further comprising monitoring the power driving the ultrasound transducer over time;
- communicating the voltage to the controller; and
- terminating the emitting ultrasound energy when the voltage of the power driving the ultrasound transducer is above a predetermined voltage threshold.
7. The method according to claim 1 further comprising monitoring a voltage of the power driving the ultrasound transducer over time;
- communicating the voltage to the controller; and
- terminating the emitting ultrasound energy when the voltage of the power driving the ultrasound transducer is below a predetermined voltage threshold.
8. The method according to claim 1 wherein correcting the ultrasound energy to the specific frequency lowers the temperature of the ultrasound transducer.

9. The method according to claim 1 further comprising modifying the temperature of the ultrasound transducer to stay within the predetermined temperature range.

10. A method of providing ultrasound energy having a stable power output, the method comprising:
 - providing ultrasound energy at a center frequency from an ultrasound transducer at a predetermined voltage;
 - monitoring a voltage level of power driving the ultrasound transducer over time;
 - communicating the voltage level to a Controller;
 - correcting the ultrasound energy to the center frequency upon a change in the voltage level of the power driving the ultrasound transducer, as compared to the predetermined voltage;
 - monitoring a temperature of the ultrasound transducer over time;
 - communicating the temperature to the controller; and
 - preventing a shift in the frequency of the ultrasound energy away from the center frequency upon a change in the temperature of the ultrasound transducer over time; thereby maximizing efficiency of the ultrasound transducer emitting the ultrasound energy.
11. The method according to claim 10 further comprising; monitoring a power level to the ultrasound transducer over time;
- communicating the power level to the controller; and
- correcting the ultrasound energy back to the center frequency upon a change of the power level to the transducer.
12. The method according to claim 10 further comprising terminating the providing ultrasound energy upon a change of the voltage level of the power driving the ultrasound transducer is above a predetermined voltage level threshold.
13. The method according to claim 10, further comprising terminating the emitting ultrasound energy when the voltage level of the power driving the ultrasound transducer is below a predetermined voltage level threshold.
14. The method according to claim 10 further comprising terminating the providing ultrasound energy upon a change of the voltage level of the power driving the ultrasound transducer is below a predetermined voltage level threshold.
15. The method according to claim 10 further comprising terminating the providing ultrasound energy when the temperature of the ultrasound transducer is above a predetermined temperature threshold.
16. The method according to claim 10 further comprising terminating the providing the ultrasound energy when the temperature of the ultrasound transducer is below a predetermined temperature threshold.
17. The method according to claim 10 further comprising terminating the providing the ultrasound energy when the voltage level of the ultrasound transducer is above a predetermined voltage threshold.
18. The method according to claim 10 wherein correcting the ultrasound energy to the center frequency lowers the voltage level of the power driving the ultrasound transducer or lowers the temperature of the ultrasound transducer.
19. The method according to claim 10 further comprising preventing a change in impedance of the ultrasound transducer.

* * * * *

UNITED STATES PATENT AND TRADEMARK OFFICE
CERTIFICATE OF CORRECTION

PATENT NO. : 9,011,337 B2
APPLICATION NO. : 13/547011
DATED : April 21, 2015
INVENTOR(S) : Michael H. Slayton et al.

Page 1 of 1

It is certified that error appears in the above-identified patent and that said Letters Patent is hereby corrected as shown below:

Title Page

Item (57) Abstract, line 6 - "communicating" should be -- monitoring --

In the Specification

Column 6, line 43 - "depths at below" should be -- depths at or below --

In the Claims

Column 15, line 46 - "monitoring the" should be -- monitoring a voltage of the --

Column 16, line 8 - "of power" should be -- of the power --

Column 16, line 26 - "hack" should be -- back --

Column 16, line 17 - "a" should be -- the --

Signed and Sealed this
Twelfth Day of July, 2016



Michelle K. Lee
Director of the United States Patent and Trademark Office

专利名称(译)	用于监视和控制超声功率输出和稳定性的系统和方法		
公开(公告)号	US9011337	公开(公告)日	2015-04-21
申请号	US13/547011	申请日	2012-07-11
[标]申请(专利权)人(译)	斯雷顿MICHAEL ^ h JAEGER PAUL		
申请(专利权)人(译)	斯雷顿, MICHAEL H. JAEGER, PAUL		
当前申请(专利权)人(译)	引导治疗系统公司		
[标]发明人	SLAYTON MICHAEL H JAEGER PAUL		
发明人	SLAYTON, MICHAEL H. JAEGER, PAUL		
IPC分类号	A61B8/00 A61N7/00 A61B18/00 A61N7/02		
CPC分类号	A61N7/00 A61N7/02 A61B2018/00678 A61B2018/00732 A61B2018/00779 A61B2018/00791 A61B8/546 A61B8/4444 A61B8/4483		
优先权	61/506609 2011-07-11 US 61/506610 2011-07-11 US		
其他公开文献	US20130018286A1		
外部链接	Espacenet USPTO		

摘要(译)

一些实施例提供了一种提供具有稳定功率输出的超声能量的方法。该方法可以包括从超声换能器提供超声能量;确定超声能量的功率水平阈值;监测超声能量随时间的功率水平;将功率电平传送给控制器;在功率水平变化时调节超声能量的频率;并保持超声能量的功率水平阈值。

