



(19) **United States**

(12) **Patent Application Publication**  
**Bogineni et al.**

(10) **Pub. No.: US 2019/0223832 A1**  
(43) **Pub. Date: Jul. 25, 2019**

(54) **FETAL ULTRASOUND MONITORING METHOD AND SYSTEM**

(52) **U.S. Cl.**  
CPC ..... *A61B 8/0866* (2013.01); *A61B 8/02* (2013.01); *A61B 5/02411* (2013.01); *A61B 5/4362* (2013.01)

(71) Applicant: **General Electric Company**,  
Schenectady, NY (US)

(72) Inventors: **Kiran Kumar Bogineni**, Bangalore (IN); **Ravi Jaiswal**, Bangalore (IN); **Shruti Gadgil**, Bangalore (IN); **Jay Mehta**, Bangalore (IN)

(57) **ABSTRACT**

A method of fetal ultrasound monitoring includes detecting contact of a first ultrasound transducer to a mother's abdomen based on input from a contact sensor in the first ultrasound transducer. A first transducer ID is received from the first ultrasound transducer, and then the first transducer ID is correlated with a first transducer label. A first heart rate is measured based on output of an ultrasound device in the first ultrasound transducer, and a heart rate indicator is displayed accordingly. A position of the first ultrasound transducer is identified in a two-dimensional plane, and the first transducer label is displayed on an abdomen image based on the first position.

(73) Assignee: **General Electric Company**,  
Schenectady, NY (US)

(21) Appl. No.: **15/877,003**

(22) Filed: **Jan. 22, 2018**

**Publication Classification**

(51) **Int. Cl.**  
*A61B 8/08* (2006.01)  
*A61B 5/00* (2006.01)  
*A61B 5/024* (2006.01)

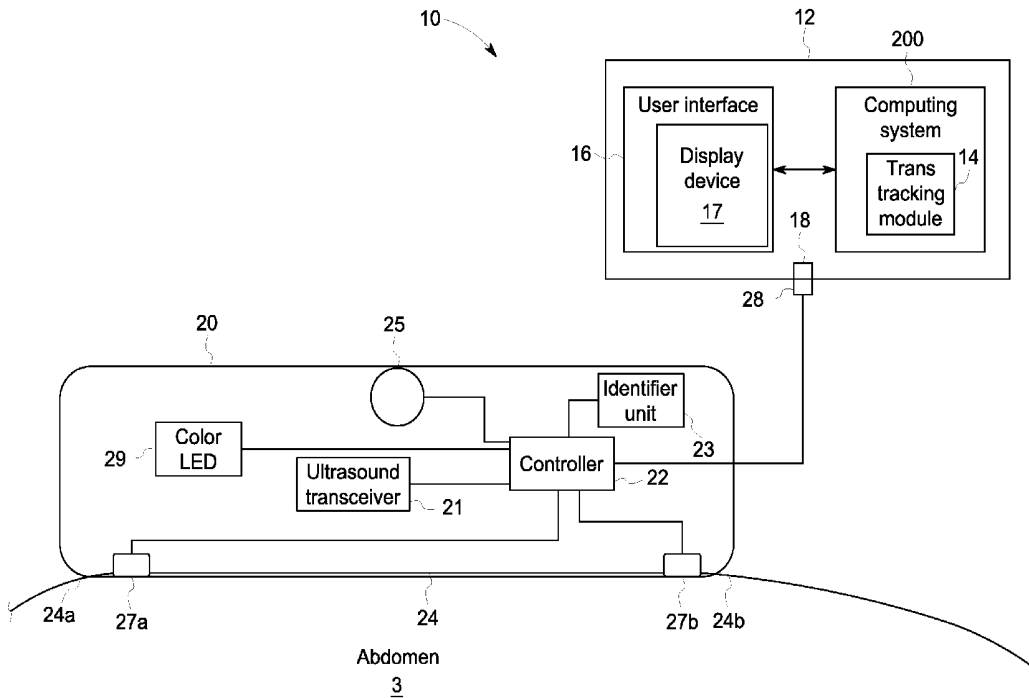

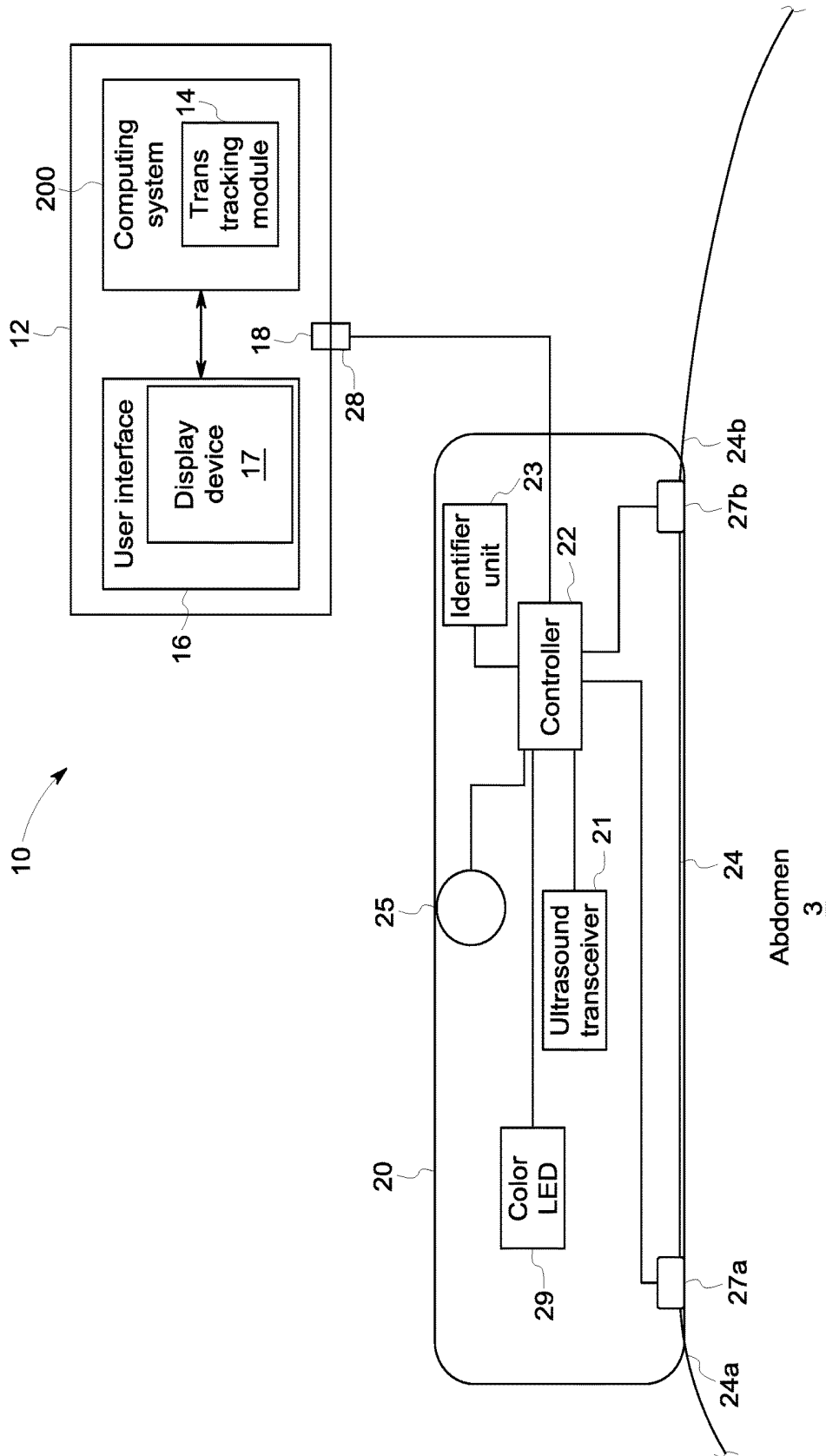

FIG. 1

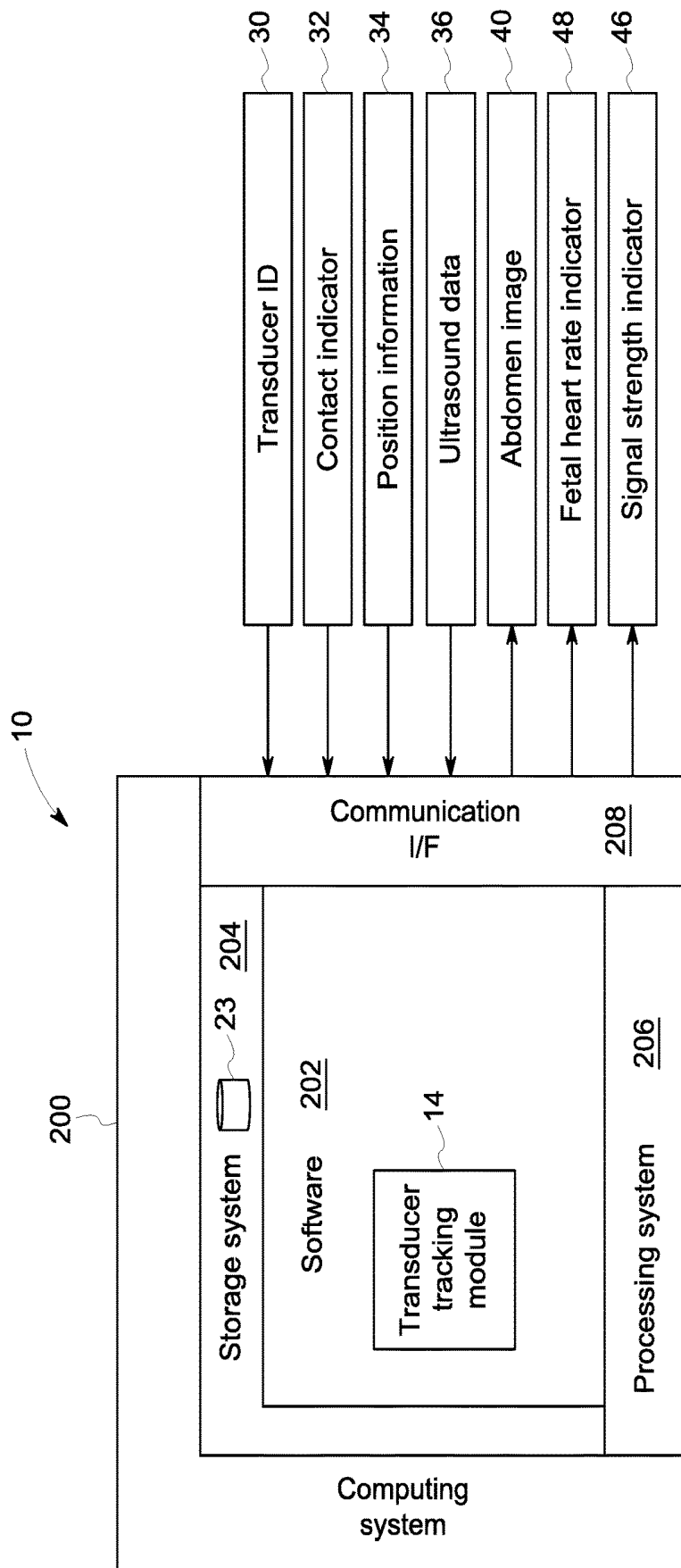

FIG. 2

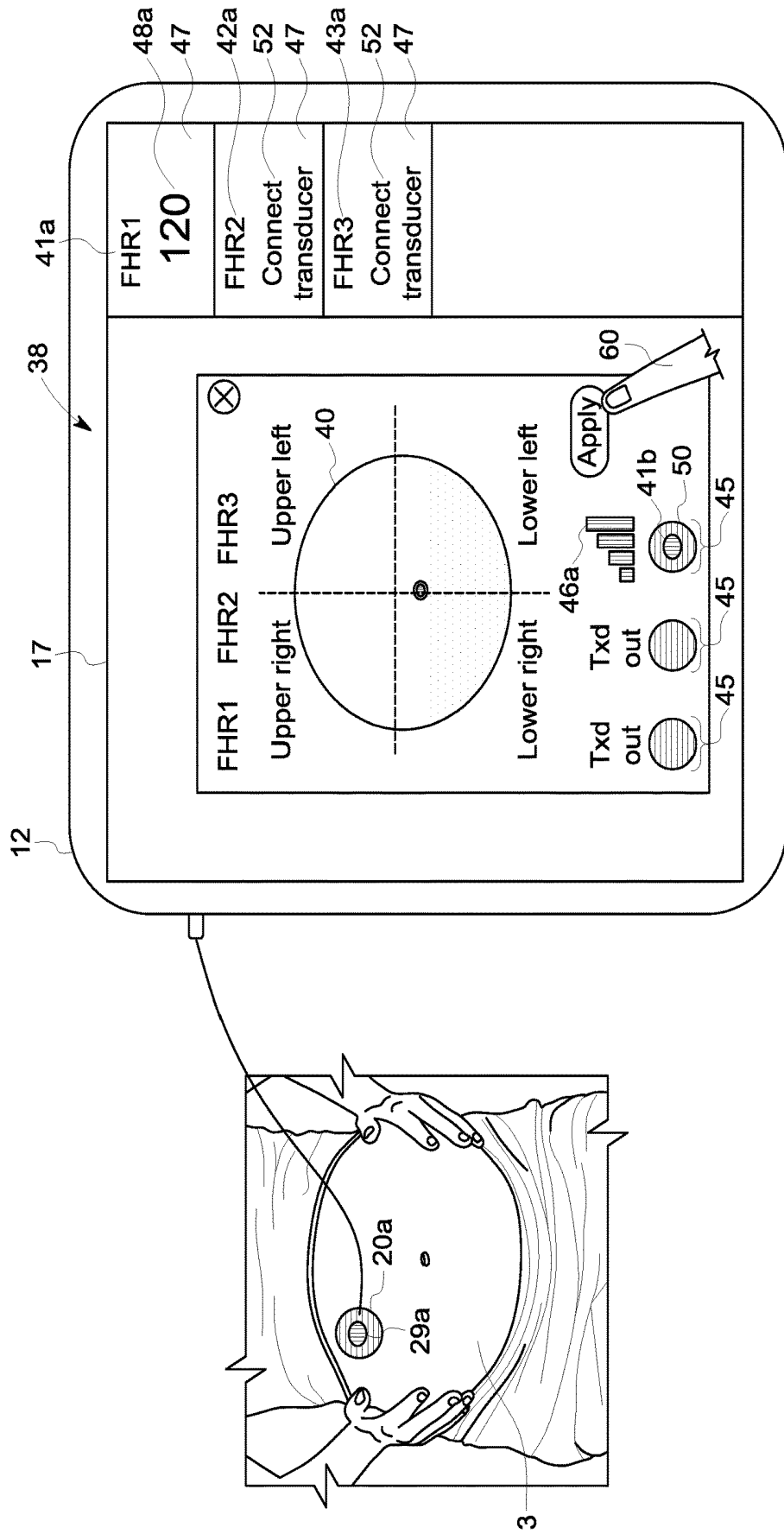

FIG. 3

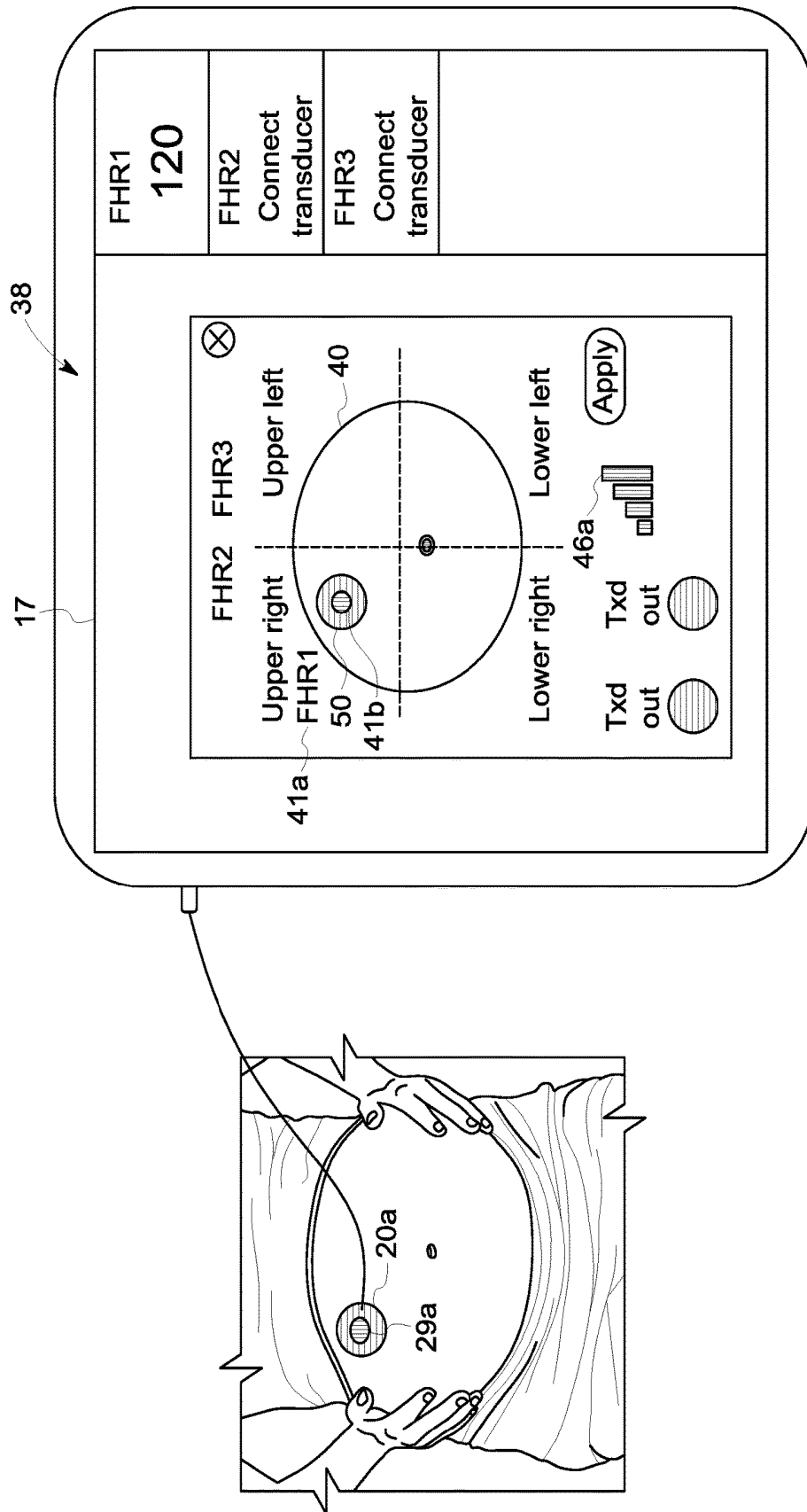

FIG. 4

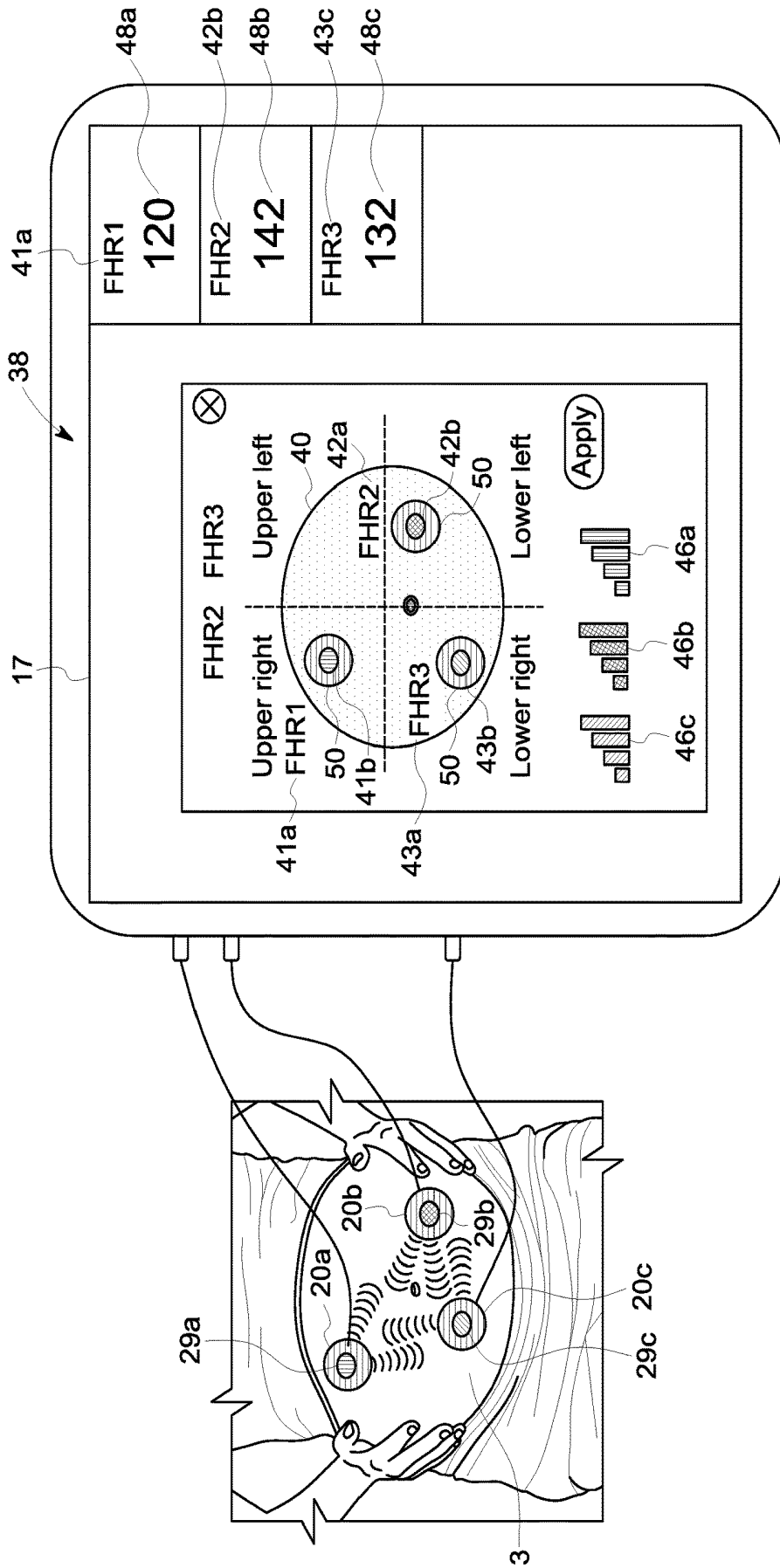

FIG. 5

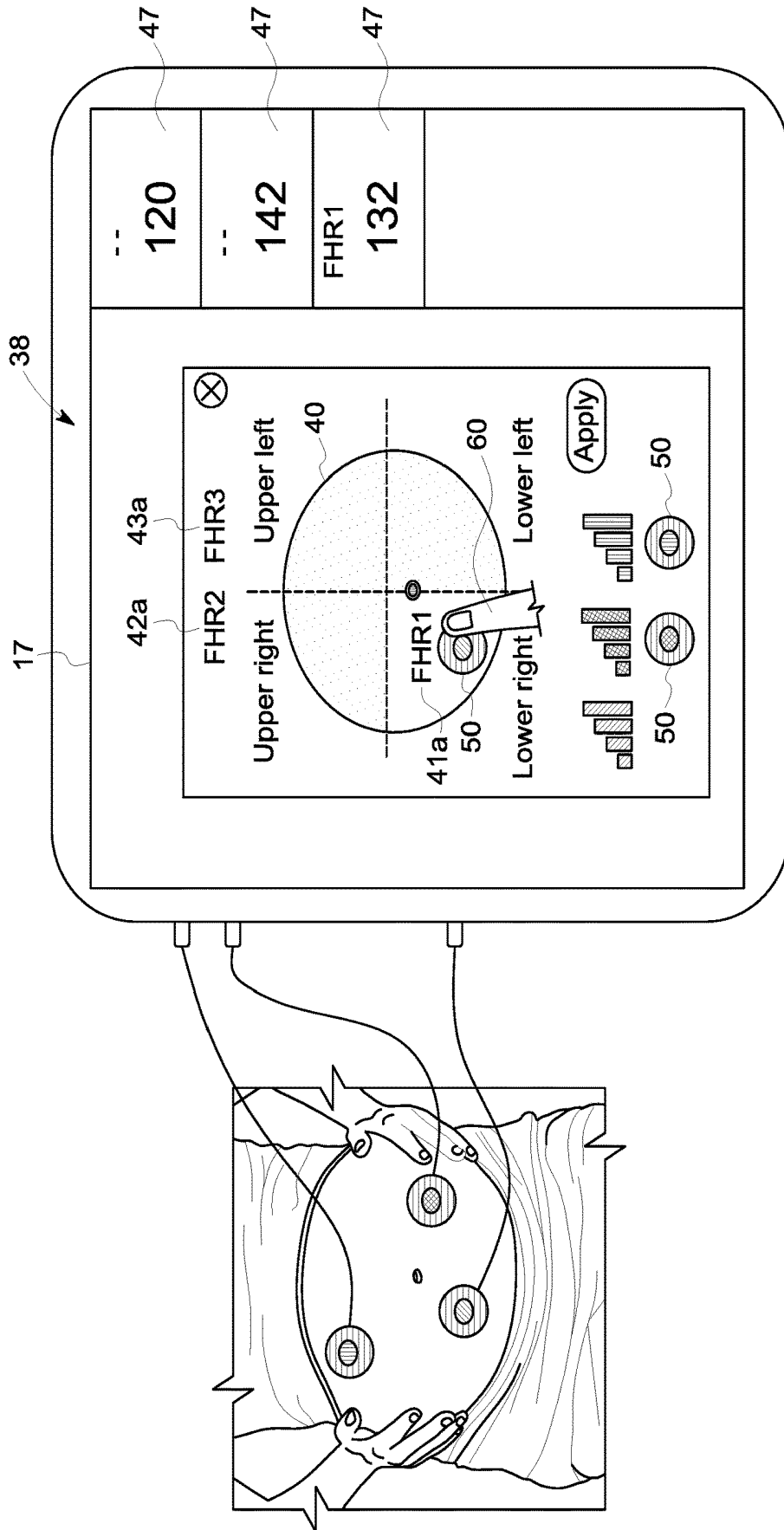

FIG. 6

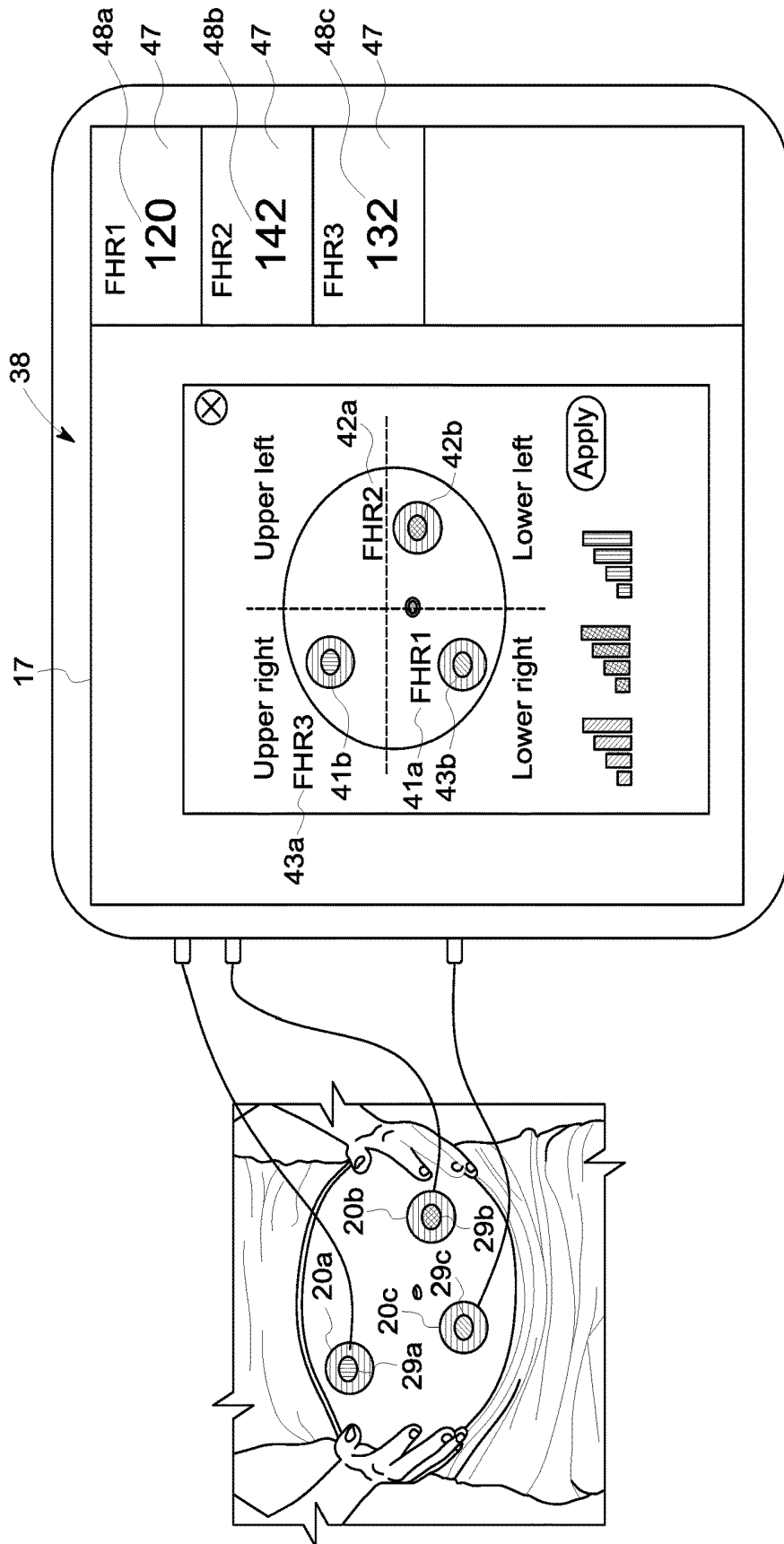

FIG. 7

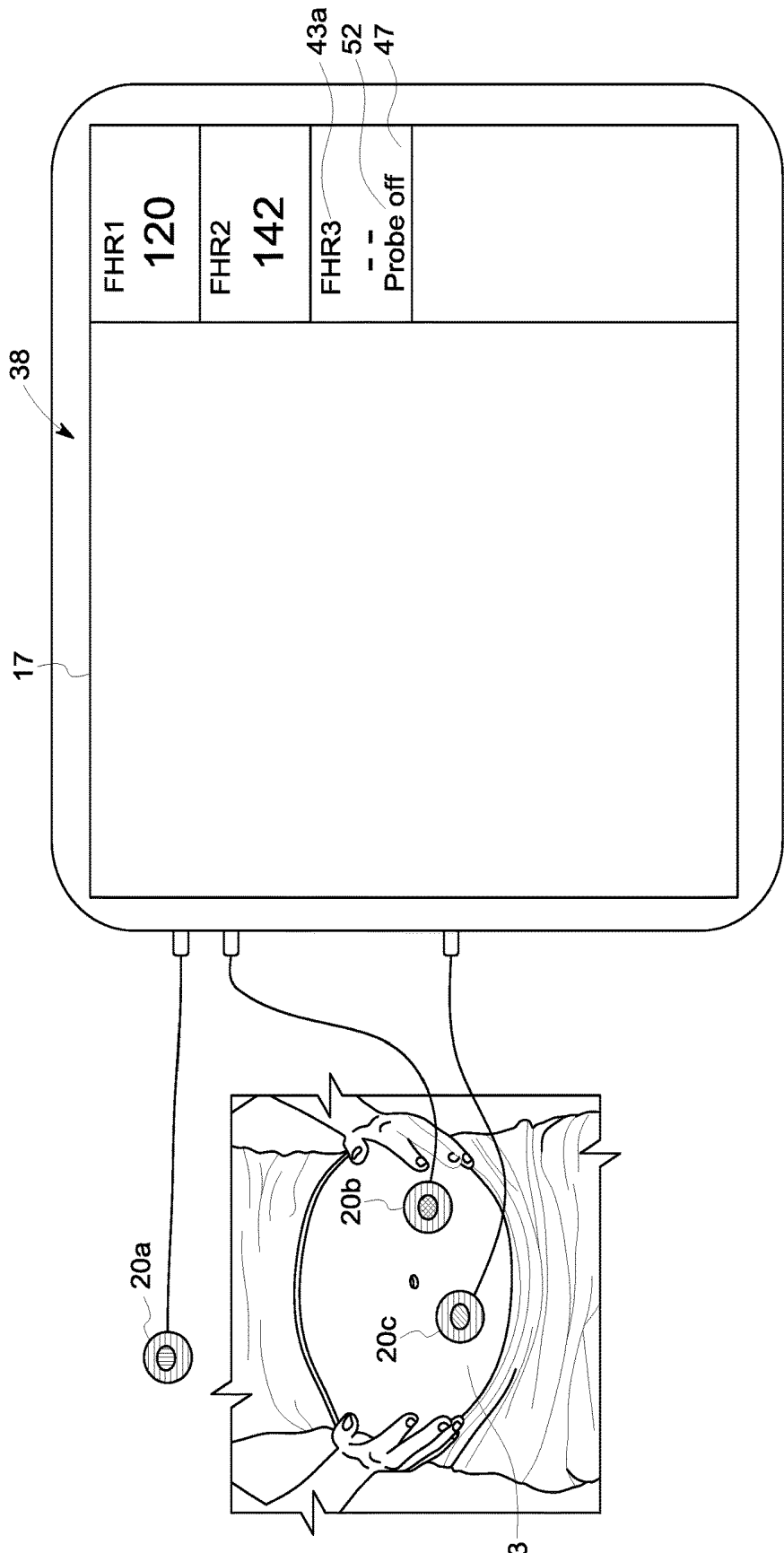

FIG. 8

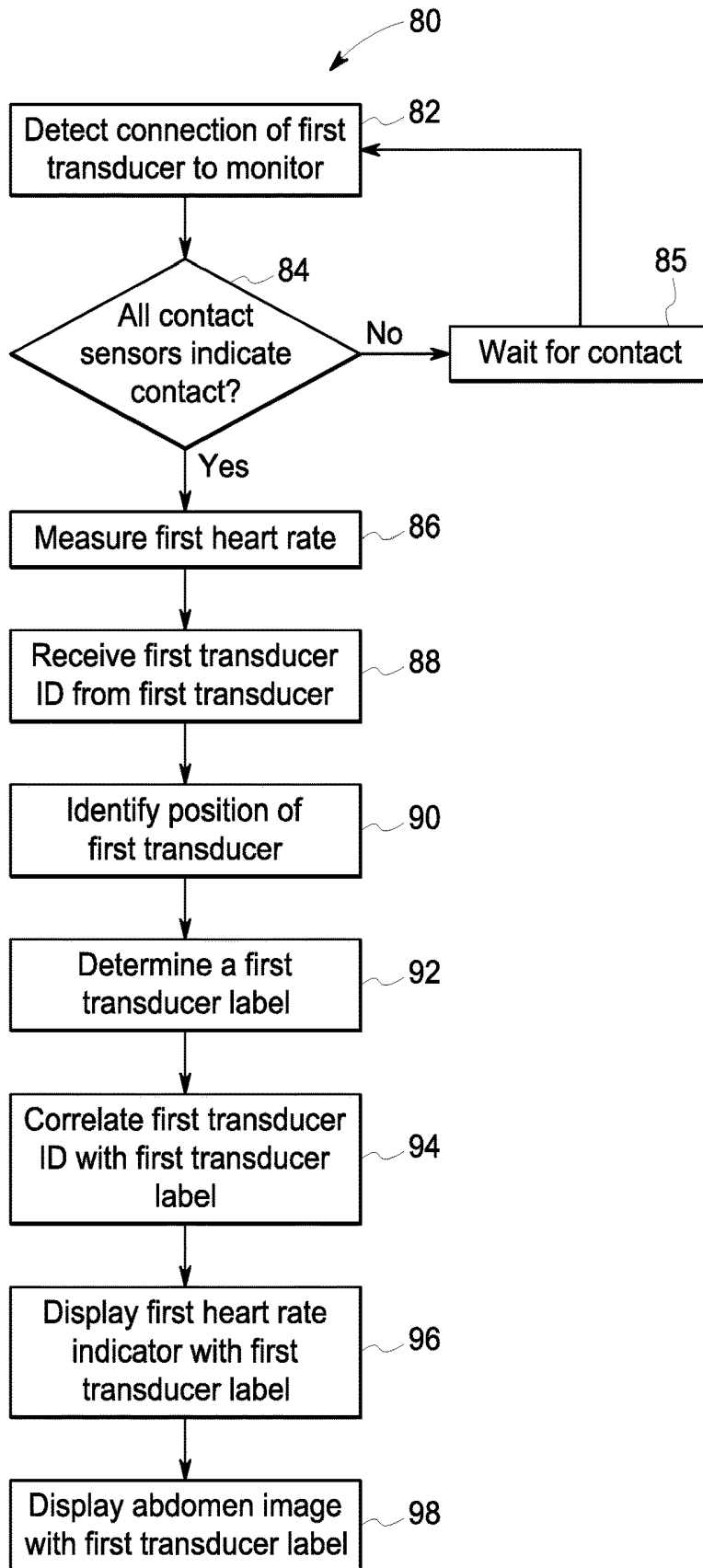

FIG. 9

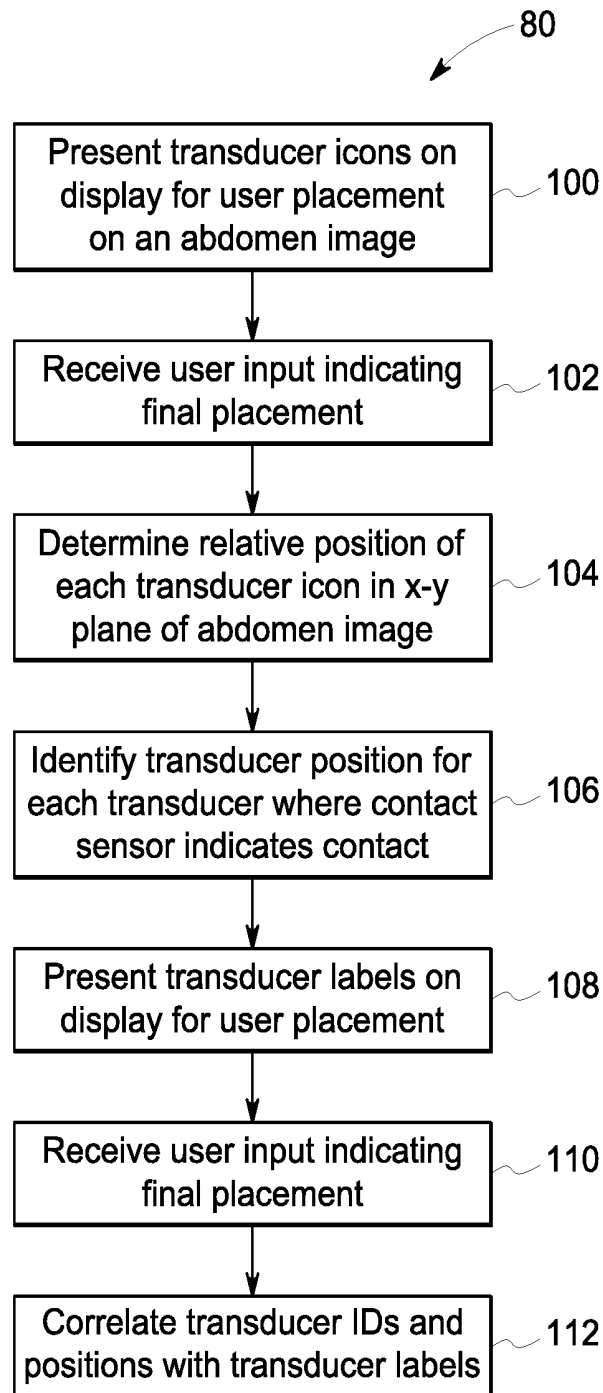

FIG. 10

## FETAL ULTRASOUND MONITORING METHOD AND SYSTEM

### BACKGROUND

[0001] The present disclosure generally relates to a method and system for fetal ultrasound monitoring, and more specifically to a fetal ultrasound monitoring system and method that tracks and displays position of fetal ultrasound transducers.

[0002] Fetal ultrasound monitoring of infant heart rate is a common infant monitoring technique to monitor and track an infant's health and current condition. Infant heart rate monitoring via a fetal ultrasound monitor, also known as cardiotocography (CTG), is a common technical means of recording fetal heartbeat and to assess fetal wellbeing, such as before or during labor. Such fetal heart rate monitoring typically occurs over a relatively long monitoring period, often lasting several hours or more. The monitoring period may be continuous, or may be several intermittent monitoring periods where the fetal heart rate is calculated from fetal heart motion measured by ultrasound.

### SUMMARY

[0003] This Summary is provided to introduce a selection of concepts that are further described below in the Detailed Description. This Summary is not intended to identify key or essential features of the claimed subject matter, nor is it intended to be used as an aid in limiting the scope of the claimed subject matter.

[0004] In one embodiment, a method of fetal ultrasound monitoring includes detecting contact of a first ultrasound transducer to a mother's abdomen based on input from a contact sensor in the first ultrasound transducer. A first transducer ID is received from the first ultrasound transducer, and then the first transducer ID is correlated with a first transducer label. A first heart rate is measured based on output of an ultrasound device in the first ultrasound transducer, and a heart rate indicator is displayed accordingly. A position of the first ultrasound transducer is identified in at least a two-dimensional plane, and the first transducer label is displayed on an abdomen image based on the first position.

[0005] In one embodiment, a fetal ultrasound system includes one or more fetal ultrasound transducers, a monitor, and a display device. Each fetal ultrasound transducer includes an ultrasound device configured to generate sound-waves in the ultrasonic range and convert reflected sound-waves into ultrasound data for detecting a fetal heartbeat. Each fetal ultrasound transducer further includes a contact sensor configured to sense contact with a mother's abdomen and generate a contact indicator. Each ultrasound transducer also includes a transducer identifier unit that communicates a transducer ID. The monitor is configured to receive the ultrasound data, the contact indicator, and the transducer ID from the one or more ultrasound transducers. The monitor comprises a transducer tracking module software executable on a processor to generate a transducer label for each of the one or more fetal ultrasound transducers and associate the transducer ID for each fetal ultrasound transducer with the respective transducer label. A fetal heartrate is determined based on the ultrasound data and a corresponding heart rate indicator is determined. A position of each of the one or more fetal ultrasound transducers is identified. An abdomen

image is generated with transducer labels positioned thereon based on the position of each of the one or more fetal ultrasound transducers. A display device is configured to display the abdomen image with the transducer label for each of the one or more fetal ultrasound transducers, and to display the fetal heart rate indicator in association with the respective transducer label.

[0006] Various other features, objects, and advantages of the invention will be made apparent from the following description taken together with the drawings.

### BRIEF DESCRIPTION OF THE DRAWINGS

[0007] The present disclosure is described with reference to the following Figures.

[0008] FIG. 1 is a schematic diagram depicting one embodiment of a fetal ultrasound system.

[0009] FIG. 2 is a schematic diagram of an exemplary computing system in a fetal ultrasound system.

[0010] FIGS. 3-8 depict exemplary embodiments of a user interface for a fetal ultrasound system, and corresponding methods of conducting fetal ultrasound monitoring.

[0011] FIGS. 9-10 depict exemplary methods, or portions thereof, of fetal ultrasound monitoring.

### DETAILED DESCRIPTION

[0012] Through their research and experience in the relevant field, the present inventors have recognized that challenges currently exist in the field of fetal heart rate monitoring relating to consistently tracking a fetal heart rate over a long monitoring period, such as spanning several hours. For example, mothers often require disconnection from a fetal heart rate monitor, such as to use the restroom, take a bath, etc. When the mother returns and is reconnected to the fetal heart rate monitor, positioning of the fetal ultrasound transducer on the mother's abdomen must be re-performed, as there is no tracking of placement of the ultrasound transducers from the previous monitoring session. Moreover, this problem is exaggerated in the case of multiples—e.g., twins, triplets, or more—where there is no way for clinicians to identify how the transducers were arranged on the mother's abdomen and which fetal ultrasound transducer was associated with which baby. Accordingly, transducer often get swapped, and thus the heartbeat tracings between monitoring sessions are not properly compared and the reliability and accuracy of fetal heart rate monitoring over the entire monitoring period is compromised.

[0013] Upon recognition of the foregoing problems and challenges in the relevant art of fetal heart rate monitoring, the inventors developed the disclosed system and method that allows position tracking of fetal heart rate transducers, such as between monitoring periods or between entirely separate monitoring sessions (e.g., conducted during different visits). The disclosed system and method identify the position of each ultrasound transducer attached to the mother's abdomen and associate a transducer ID provided by each fetal ultrasound transducer with the corresponding position. The system further creates and displays an abdomen image with transducer labels positioned thereon based on the position of each of the one or more fetal ultrasound transducers.

[0014] FIGS. 1 and 2 depict one embodiment of a fetal ultrasound system 10 including a fetal ultrasound transducer 20 connected to a mother's abdomen 3 for monitoring fetal

heart rate. Although FIG. 1 shows only one fetal ultrasound transducer 20, it should be understood that the fetal ultrasound system 10 may include any number of one or more fetal ultrasound transducers 20, each having the elements depicted and described with respect to FIG. 1. Each fetal ultrasound transducer 20 includes an ultrasound device 21, such as an ultrasound transceiver configured to generate waves in the ultrasonic range, to sense reflected sound waves and generate corresponding electrical signals that comprise ultrasound data for detection of fetal heartbeat. To provide just one exemplary embodiment, the ultrasound device 21 may be a single piezoelectric transceiver comprised of a number of piezoelectric crystals distributed across the device. In other embodiments, the ultrasound device 21 may comprise separate ultrasound transmitters and receivers, each being a separate set of piezoelectric crystals.

[0015] The fetal ultrasound transducer further includes one or more contact sensors 27 configured to sense contact with patient's skin and generate a contact indicator 32 based thereon. For example, the contact sensor 27 may comprise one or more capacitive sensors 27a, 27b positioned at opposing ends of the contact surface 24 of the ultrasound transducer 20. In such an embodiment, the contact indicator 32 includes a capacitance measured by each of the respective capacitive contact sensors 27a, 27b, and determines that the fetal ultrasound transducer 20 is connected to the mother's abdomen 3 when less than a threshold capacitance is detected by both capacitive sensors 27a, 27b.

[0016] The fetal ultrasound transducer 20 is configured to connect to a monitor 12. In the depicted embodiment, the transducer physically connects to the monitor 12 by connecting transducer plug 28 of the fetal ultrasound transducer 20 to a transducer receiver 18 in the monitor 12. In embodiments containing more than one fetal ultrasound transducer 20, each fetal ultrasound transducer 20 may have a separate transducer plug 28 that is received by or mates with a separate transducer receiver 18 in the monitor 12. In other embodiments, communication between the fetal ultrasound transducer 20 and the monitor 12 may be via wireless means, such as via any known wireless communication protocol. In such an embodiment, the fetal ultrasound transducer 20 may further comprise a wireless receiver/transmitter that communicates with a receiver/transmitter in the monitor 12. In such an embodiment, the monitor may comprise a separate receiver/transmitter for each fetal ultrasound transducer 20, or a receiver/transmitter that communicates with all ultrasound transducers 20 wirelessly communicating with the monitor 12.

[0017] The ultrasound transducer 20 further includes a transducer identifier unit 23 that communicates a transducer ID 30 to the monitor 12. The transducer identifier unit 23 may be, for example, a set of information stored and accessible at a certain location in the non-volatile memory of each transducer 20. In other embodiments, the identifier unit 23 may be a separate device, such as an ID chip, that provides the transducer ID 30 by either wireless or wired means. In certain examples, the transducer ID 30 comprises a vendor ID, a product ID, and a unique serial number generated and programmed into the device by the manufacturer. The product ID may, for example, contain information regarding the colored LED 29 contained in the particular transducer 20. Such information may be provided to the monitor 12 by any communication means and/or protocol, such as via a USB interface with the monitor 12.

[0018] The monitor 12 receives the ultrasound data 36, the contact indicator 32, and the transducer ID 30 from the one or more ultrasound transducers 20 connected thereto (e.g., by either wired or wireless means). The monitor 12 includes software comprising a transducer tracking module 14 executable on a processor to track the respective ultrasound transducers 20. The transducer tracking module 14 may execute steps to generate a transducer label 41, 42, 43 for each ultrasound transducer 20, and associate the transducer ID 30 with a respective transducer label 41, 42, 43, as explained in more detail below. The transducer tracking module 14 further identifies a position of each of the one or more fetal ultrasound transducers 20 connected to the monitor 12, and associates the respective transducer ID and transducer label 41, 42, 43 therewith. The transducer tracking module 14 generates an abdomen image 40 with the transducer labels 41, 42, 43 positioned thereon to visually represent the placement of the ultrasound transducers 20 on the patient's abdomen.

[0019] The monitor 12 includes or is associated with a display device 17 comprising part of a user interface system 16 including a display device 17 configured to display the abdomen image 40 with the transducer label 41, 42, 43 for each of the one or more fetal ultrasound transducers 20a, 20b, 20c. The display device 17 is also configured to display a fetal heart rate indicator 48 in association with the respective transducer label 41, 42, 43 for that fetal ultrasound transducer 20. In the depicted embodiment, the display device 17 is a touch screen display allowing user input as interaction with the user interface display 38. The display device 17 may include any type of touch screen interface layered on top of the electronic visual display of the display device 17, such as a capacitive touch screen panel, a resistive touch screen panel, or other touch screen technology.

[0020] In certain embodiments, each ultrasound transducer 20 may include an illuminable device 29, such as a colored LED 29. In certain examples, each ultrasound transducer 20 attached to the monitor 12 displays a different color light than the other transducers attached to the same monitor 12. In other embodiments, the illumination device 29 may comprise of a different type of illuminable device or may comprise multiple colored LEDs that are selectively illuminable by the controller 22 within the respective fetal ultrasound transducer 20. For example, the illumination device 29 may be illuminable in at least two different colors, and the controller 22 may be configured to control the illumination device to select one of the at least two different colors based on the transducer label 41, 42, 43 assigned thereto. To provide just one example, the illumination device 29 may comprise multiple different colored LEDs, one of which may be selected and illuminated to correspond with the transducer label 41, 42, 43 assigned by the transducer tracking module 14 to that particular fetal ultrasound transducer 20. Thereby, the illumination device 29 may be illuminated in a color to correspond to the color for the respective ultrasound transducer provided on the user interface display 38. Thereby, each respective fetal ultrasound transducer is visually associable with the abdomen image 40 and the transducer labels 41, 42, 43 provided thereon.

[0021] In certain embodiments, each of the one or more fetal ultrasound transducers 20 may comprise a position sensor 25 configured to measure position information 34 of that fetal ultrasound transducer within a two-dimensional plane or a three-dimensional space. Thereby, the position of

each of the fetal ultrasound transducers is automatically determined based on the position information 34 measured by the position sensor 25. In one exemplary embodiment, the position sensor 25 may be an electromagnetic transmitter/receiver in each transducer 20a, 20b, 20c that communicate to determine a relative location among the transducers 20a, 20b, 20c. To provide just one example, each position sensor 25 may include an ultrasonic transmitter/receiver that selectively transmits and receives ultrasonic pulses to the position sensor(s) in other transducers 20b, 20c. Alternatively or additionally, the position sensors 25 may include an inertial measurement unit (IMU) containing a triad of gyroscopes and triad of accelerometers and measuring linear and angular motion. Accordingly, the position information 34 may include IMU data providing position information in three-dimensional space, and relative position information consisting of two-dimensional distance information describing position relative to one or more other of the ultrasound transducers.

[0022] In other examples, the position sensor 25 may be an IR-based optical sensor embedded within each transducer 20. Each infrared (IR) position sensor 25 transmits and receives IR data. Based on the reflective intensity measured using the optical fibers of each position sensor 25, the distance(s) between the transducers can be determined and communicated to the monitor 12, such as through the aforementioned USB interface.

[0023] In certain embodiments, the fetal ultrasound transducer 20 may further include a controller 22 that communicates with the various devices and systems within the ultrasound transducer 20, including the ultrasound transceiver 21, the identifier unit 23, the contact sensor(s) 27, and/or the position sensor 25. The controller 22 may control communication between the respective elements and the monitor 12, such as to receive the ultrasound data 36 from the ultrasound transceiver 21, the transducer ID 30 from the transducer identifier unit 23, and/or the contact indicator 32 from the contact sensor(s) 27, and facilitate communication of those values to the monitor 12. Similarly, the controller 22 may function to provide control signals to the respective elements 21, 23, 25, 27, 29 based on control instructions provided by the monitor 12, such as generated by the transducer tracking module 14.

[0024] In certain embodiments, the controller 22 may also provide power distribution and control function, receiving power from a power source and distributing it to the various elements 21, 23, 25, 27, 29 according to the needs of the fetal ultrasound system 10. In embodiments where the fetal ultrasound transducer 20 physically connects to the monitor 12, the monitor 12 may be the power source for the fetal ultrasound transducer 20, and thus power may be provided from the monitor 12 through the transducer plug 28 and cord to the fetal ultrasound transducer 20. In other embodiments where the fetal ultrasound transducer 20 is a wireless device, a battery may be connected thereto, and power from the battery controlled and distributed by the controller 22.

[0025] FIGS. 3-8 depict various embodiments of a user interface display 38 provided on a display device 17 and generated by the user interface system 16. The user interface display 38 generally provides an abdomen image 40 and a transducer label 41, 42, 43 associated with each of the one or more ultrasound transducers 20. In certain embodiments, a first step may be performed via the user interface display 38 to select the number of fetuses for which heart rate

monitoring will occur, such as a single fetus, twins, triplets, etc. For example, the user interface display 38 may be configured to provide an initial screen allowing a user to select a number of fetuses. The user interface display may then automatically display a corresponding number of active transducer indicator locations 45 and parameter blocks 47. In other embodiments, the user interface system 16 may be configured to automatically display a number of active transducer indicator locations 45 and/or parameter blocks 47 based on a number of fetal ultrasound transducers 20 connected to the monitor 12. For example, the transducer tracking module 14 may be configured to automatically detect when a transducer plug 28 of a fetal ultrasound transducer 20 is connected to respective transducer receiver 18 in the monitor 12, and to adjust the user interface display 38 to provide the active transducer indicator location 45 and parameter block 47 accordingly. In still other embodiments, a default number of active transducer indicator locations 45 and parameter blocks 47 may be provided and may remain blank until a fetal ultrasound transducer 20 is connected to the monitor 12 and provides information to be displayed.

[0026] In the example of FIG. 3, one fetal ultrasound transducer 20a is positioned on the mother's abdomen 3 and is connected to the monitor 12. Accordingly, one active transducer indicator location 45 and a first parameter block 47 display a first transducer label 41 associated with that fetal ultrasound transducer 20. The transducer label 41 may be any type of visual label that identifies the respective fetal ultrasound transducer 20a. In the depicted embodiment, the first transducer label 41 includes an alphanumeric label 41a identifying "FHR1" indicating the device and physiological parameters are associated with a first fetus. The first transducer label 41 may also include a color indicator 41b, which may be an alternative or in addition to the alphanumeric label 41a. The color label 41b indicates a color associated with the respective transducer 20a, which may be provided at numerous locations on the user interface display 38, such as on a transducer icon 50 and/or indicating the respective physiological parameters and aspects of the user interface display 38 associated with the first fetus and the first fetal ultrasound transducer 20a.

[0027] The user interface display 38 may further provide a signal strength indicator 46 to indicate the signal strength of the heartbeat measurement by the fetal ultrasound transducer 20. This is a visual indication of the strength of the heartbeat measurement and can be used by a clinician to optimally place the respective fetal ultrasound transducer 20 on the mother's abdomen 3. For example, the clinician placing the ultrasound transducer 20 may move the transducer 20 based on the signal strength indicator 46 in order to select an optimal location for measuring the respective fetus' heartbeat. In the depicted embodiment, the signal strength indicator for the first ultrasound transducer 20a is provided in the associated active transducer location 45, and is provided in a color that corresponds with the first transducer label 41b. Namely, the signal strength indicator 46a is provided in red, the same color as the first transducer label 41b, providing an additional visual indication of the fetal ultrasound transducer 20a to which the signal strength indicator 46a belongs.

[0028] Providing additional visual association between the fetal ultrasound transducer 20a and associated parts of the user interface display 38, the fetal ultrasound transducer 20a may comprise a light source 29, such as a colored LED, that

illuminates in the same color as the respective transducer label **41b**. In the embodiment depicted in FIG. 3, the first fetal ultrasound transducer **20a** has red illumination source **29**, such as a red LED, that corresponds with the red color of the first transducer label **41b**.

[0029] In certain embodiments, the transducer tracking module **14** automatically determines the fetal heart rate and displays a corresponding fetal heart rate indicator **48** upon detecting that a respective fetal ultrasound transducer **20** is connected to a mother's abdomen **3** and connected to the monitor **12**. For example, upon detecting less than a threshold capacitance from the capacitive contact sensors **27a**, **27b**, the fetal ultrasound system **10** may be configured to automatically measure and display fetal heart rate determined based on ultrasound data **36** gathered by the respective ultrasound transducer **20**. In such an embodiment, the fetal heart rate indicator **48** may be automatically displayed in association with respective transducer label, including the alphanumeric transducer label **41a** and/or the color transducer label **41b**. In other embodiments, the transducer tracking module **14** may be configured to determine and display the fetal heart rate upon input from a user instructing such determination and/or acknowledging placement of the respective fetal ultrasound transducer **20**. For example, referencing FIG. 3, the clinician may provide input via the user interface display **38** once the respective fetal ultrasound transducer **20a** has been placed, such as based on guidance provided by the signal strength indicator **46a**. In the example of FIG. 3, such input by a user **60** is provided by selecting the "apply" button on the touch screen display device **17**.

[0030] The transducer tracking module **14** is further executed to associate the transducer ID **30** for the respective ultrasound transducer **20a**, **20b**, **20c** with each transducer label **41**, **42**, **43** for that respective device. Thereby, the respective fetal heartbeat recordings and/or fetal heart rate indicators can be associated with a particular ultrasound transducer **20a**, **20b**, **20c**. That particular transducer **20a**, **20b**, **20c** is associated with a location on the mother's abdomen **3**. Thus, in the case of multiples, the ultrasound transducer **20a**, **20b**, **20c** is associated with a particular fetus.

[0031] A position of each of the one or more ultrasound transducers **20a**, **20b**, **20c** connected to the monitor **12** is identified by the transducer tracking module **14**. Such position identification may be based on user input provided at the user interface display **38**, or may be determined automatically by the system **10**. The abdomen image **40** is then adjusted to provide transducer icons **50** with respective transducer labels **41**, **42**, **43** positioned thereon based on the position of each of the one or more fetal ultrasound transducers **20a**, **20b**, **20c**.

[0032] FIG. 4 provides an exemplary embodiment showing the first transducer label **41** positioned on the abdomen image **40** to correspond with the position of the first ultrasound transducer **20a** on the mother's abdomen **3**. As additional fetal ultrasound transducers **20b**, **20c** are attached to the mother's abdomen **3**, such fetal ultrasound transducers are added to the abdomen image **40**. FIG. 5 provides one example where three fetal ultrasound transducers **20a**, **20b**, and **20c** are connected to the mother's abdomen **3** and represented accordingly as transducer icons **50** on the abdomen image **40**, differentiated by the respective transducer labels **41**, **42**, **43** positioned thereon. As shown, the alphanumeric transducer labels **41a**, **42a**, **43a** are displayed next to the circular image representing each ultrasound trans-

ducer **20a**, **20b**, **20c**. Similarly, a color transducer label **41b**, **42b**, **43b** is provided within each circular transducer icon **50**, the color of which corresponds to the colored illumination source **29** of the respective ultrasound transducer **20a**, **20b**, **20c**. In the example, each of the ultrasound transducers **20a**, **20b**, **20c** has an illumination device **29** being a colored LED **29a** (red), **29b** (orange), and **29c** (green). Correspondingly, everything associated with the first ultrasound transducer **20a** is provided in red (transducer label **41b**), everything associated with the second ultrasound transducer **20b** is provided in orange (transducer label **42b**), and everything associated with the third ultrasound transducer **20c** is provided in green (transducer label **43b**). In certain embodiments, the color of the respective illumination device **29a**, **29b**, **29c** may be provided as part of the transducer ID **30**, and the color transducer labels **41b**, **42b**, **43b** may be assigned accordingly.

[0033] In embodiments where the ultrasound transducers **20a**, **20b**, **20c** have position sensors therein, the transducer positions may be automatically determined, and the corresponding abdomen image **40** may be generated automatically based on the position information **34** measured by each position sensor **25**. Namely, the transducer tracking module **14** may automatically generate an abdomen image **40** having transducer icons **50** showing the location of each transducer **20** and labeled accordingly. For example, the three transducers **20** shown in FIG. 5 may each comprise a position sensor **25** having an IMU and electromagnetic receiver/transmitter that communicates with the various other sensors (e.g. via ultrasound) to determine a relative location. The abdomen image **40** may be automatically generated based on such information. Further, the abdomen image **40** may be automatically updated if one of the transducers **20a**, **20b**, **20c** is repositioned, for example. Thereby, the relative movements of the ultrasound transducers **20a**, **20b**, **20c** can be tracked and visualized on the user interface display **38**.

[0034] In other embodiments, the position of each ultrasound transducer may be identified based on user input. FIG. 6 provides one example of how such user input may be provided via the user interface display **38**. In the example embodiment, user input regarding transducer position is provided by placing each transducer icon **50** onto the abdomen image **40**. For example, the user interface display **38** may be designed to facilitate such user input by allowing the user **60** to select each transducer icon **50** and place it on the abdomen image **40**. In the depicted example, the user interface display **38** is a touch screen configured to receive touch input by the user **60** to place the transducer icons **50**, as shown. In certain embodiments, the user interface display **38** may be further arranged to allow the user to associate the transducer labels **41**, **42**, **43** with each transducer icon **50** indicating the respective position on the abdomen image, and thereby with each corresponding transducer ID **30**. For example, the user interface display **38** may be configured to allow a user **60** to select each transducer label, such as by touching the label on the screen, and placing each label next to a corresponding transducer icon **50** (e.g. placed on the abdomen image **40** by the clinician). In certain embodiments, once all transducer labels are associated with respective transducer icons, the user may hit apply, at which point the transducer ID **30** for each respective ultrasound transducer **20a**, **20b**, **20c** may be associated with each of the transducer labels **41**, **42**, **43**.

[0035] In various fetal ultrasound system 10 configurations and embodiments, the transducer labels 41, 42, 43 may be automatically assigned by the transducer tracking module 14, or may be assigned based on user input. In certain embodiments described herein, the alphanumeric transducer labels 41a, 42a, 43a may be assigned separately from the color transducer labels 41b, 42b, 43b. For example, the color transducer labels 41b, 42b, 43b may be automatically assigned, such as based on information transmitted as part of the transducer ID 30; while the alphanumeric transducer labels 41a, 42a, 43a may be manually assigned. In other embodiments, all alphanumeric transducer labels 41a, 42a, 43a and color transducer labels 41b, 42b, 43b may be manually assigned or automatically assigned (which, in embodiments with position sensors 25, may account for the sensed position of the transducer).

[0036] For automatic assignment, the transducer tracking module 14 may assign the transducer labels according to an order of connection of the fetal ultrasound transducers 20 to the monitor 12. For example, the first fetal ultrasound transducer 20a to be connected to the monitor 12 may be assigned the first transducer label 41, the second fetal transducer 20b to be connected to the monitor 12 may be assigned the second transducer label 42, and the third fetal ultrasound transducer 20c connected to the monitor 12 may be assigned the third transducer label 43. The fetal heart rate indicator 48 and/or heartbeat traces, and the transducer icon 50 may then be automatically displayed accordingly on the user interface display 38, such as exemplified in FIGS. 3-8.

[0037] In certain embodiments, the transducer tracking module 14 may provide an initial transducer label 41, 42, 43, such as based on the order of connection to the monitor 12, which may then be later adjusted during the monitoring and data presentation process. For example, the transducer tracking module 14 may automatically adjust the assigned transducer labels 41, 42, 43 based on sensed position as additional transducers 20 are connected, such as according to the logic described below. Alternatively or additionally, the user interface display 38 may be configured to facilitate and receive user input to adjust the transducer labels 41a, 41b, 42a, 42b, 43a, 43b, such as by the touch input procedures described above with respect to FIG. 6. Accordingly, by either automatic or manual procedures, some or all of the transducer labels 41a, 41b, 42a, 42b, 43a, 43b may be reorganized, reassigned, and represented, such as exemplified in FIGS. 6-7.

[0038] One commonly preferred way of organizing the fetal heart rate information is to assign them from lowest to highest. Namely, the lowest positioned fetus (i.e., that positioned closest to the cervix) is designated the first fetus, the second highest fetus designated as second, and so on. Accordingly, the transducer tracking module 14 may utilize the position information 34 provided by the position sensors 25 to assign the transducer labels 41a, 41b, 42a, 42b, 43a, 43b and/or to reorganize the transducer label assignment as additional fetal ultrasound transducers 20 are connected to the mother's abdomen 3 and to the monitor 12. Thus, the transducer tracking module 14 may determine the lowest positioned fetal ultrasound transducer 20 on the mother's abdomen 3 based on the position information 34 describing the position of the ultrasound transducer 20a, 20b, 20c within the two-dimensional plane.

[0039] Upon such assignment, or reassignment, the transducer IDs 30 for each of the fetal ultrasound transducers

20a, 20b, 20c are assigned or associated with the respective transducer labels 41, 42, 43 accordingly. In certain embodiments, the alphanumeric transducer labels 41a, 42a, 43a may be reorganized and/or reassigned upon connection of all of the fetal ultrasound transducers 20a, 20b, 20c, but the originally-assigned transducer labels 41b, 42b, 43b may remain the same. With reference to FIG. 7, for example, the assignment of the alphanumeric transducer labels 41a, 42a, 43a are reorganized to swap the original assignment of the first alphanumeric transducer label 41a and the third alphanumeric transducer label 43a according to the position of the respective fetal ultrasound transducers 20c and 20a. However, the color transducer labels 41b and 43b remain the same, which continue to match the colored LEDs 29a and 29c on the respective fetal ultrasound transducers 20a and 20c. Thus, the lowest positioned fetal ultrasound transducer 20a, 20b, 20c may be assigned the first alphanumeric transducer label 41a. The next lowest fetal ultrasound transducer 20a, 20b, 20c with respect to the two dimensional plane may then be identified and assigned the second alphanumeric transducer label 42a, and so on. Such change may be made, for example, once all of the fetal ultrasound transducers are connected, such as upon receipt of user input indicating that the position of all devices has been finalized. The parameter blocks 47 presenting the fetal heart rate indicators 48 may also be reorganized accordingly, such as to present the first fetal heart rate indicator 48a ("FHR1") at the highest location and the third fetal heart rate indicator 48c ("FHR3") in the lowest location.

[0040] In other embodiments, such assignment of the transducer labels 41, 42, 43 may be manually provided by the user via the user interface display 38, such as by touching and dragging the respective alphanumeric transducers labels 41a, 42a, 43a and the color transducer labels 41b, 42b, 43b and placing them in a position adjacent to the transducer icon 50 for the respective fetal ultrasound transducer 20a, 20b, 20c.

[0041] In certain embodiments, the transducer tracking module 14 may be configured to operate the user interface display 38 to provide certain status alerts 52 to an operator. Referring to FIG. 8, for example, the transducer tracking module 14 may be configured to provide a "probe off" status alert 52 in connection with a transducer label 41, 42, 43 when an associated fetal ultrasound transducer 20a, 20b, 20c has been removed or has fallen off the mother's abdomen 3. For example, if the one or more capacitive sensors 27a, 27b detect less than the threshold capacitance, then the "probe off" status alert 52 may be provided for that transducer on the user interface display 38. In the example of FIG. 8, the fetal ultrasound transducer 20A associated with the third alphanumeric transducer label 43a (FIG. 7) is disconnected from the mother's abdomen 3. Accordingly, no fetal heart rate indicator 48 is provided in the corresponding parameter block 47, and instead a "probe off" status alert 52 is displayed. In certain examples the abdomen image may be adjusted to reflect the missing transducer. Another example is shown at FIG. 3, where the status alert 52 indicates that no ultrasound transducer is connected to the monitor 12 in association with a respective transducer label 41a, 42a, 43a, 41b, 42b, 43b. In the example, the status alert 52 displays "connect transducer" indicating that no fetal ultrasound transducer 20 is connected to the monitor, such as at the corresponding transducer receiver 18.

[0042] Accordingly, the system and method described herein enable tracking of fetal ultrasound transducers **20a**, **20b**, **20c** so that the transducers can be repositioned to measure heart rate from the same fetus between monitoring sessions. For example, the user interface display **38** generated from the previous session can be displayed in order to instruct a clinician on where and how to connect the respective ultrasound transducers **20a**, **20b**, **20c**—e.g. starting with the previously—applied configuration.

[0043] Furthermore, if the clinician were to misplace, or swap one or more of the fetal ultrasound transducers, then the system may automatically detect such an error. In that event, the system may generate an alert to a clinician regarding the misplacement. Alternatively or additionally, in situations where the placement of two fetal ultrasound transducers **20a**, **20b**, **20c** are swapped in position, the transducer tracking module **14** may be configured to automatically compensate for the swap, and reassign the transducer labels **41a**, **42a**, **43a**, **41b**, **42b**, **43b** accordingly. Moreover, the transducer tracking module **14** may be configured to automatically associate and correlate the previously measured fetal heart rate data correctly with the newly gathered fetal heart rate data, accounting for the detected transducer swap.

[0044] FIG. 2 is a schematic diagram of an exemplary computing system **200** in a fetal ultrasound monitor **12**. The computing system **200** includes a processing system **206**, storage system **204**, software **202**, and communication interface **208**. The processing system **206** loads and executes software **202** from the storage system **204**, including the transducer tracking module **14**, which is an application within the software **202**. The transducer tracking module **14** includes computer-readable instructions that, when executed, direct the processing system **206** to operate as described in herein in further detail, including to execute the steps to identify the position of each fetal ultrasound transducer **20** and to provide an abdomen image **40** having transducer icons and/or labels located thereon depicted said transducer positions.

[0045] Although the computing system **200** as depicted in FIG. 2 includes one software **202** encapsulating one transducer tracking module **14**, it should be understood that one or more software elements having one or more modules may provide the same operation. Similarly, while description as provided herein refers to a computing system **200** and a processing system **206**, it is to be recognized that implementations of such systems can be performed using one or more processors, which may be communicatively connected, and such implementations are considered to be within the scope of the description.

[0046] The processing system **206** includes a processor, which may be a microprocessor, a general purpose central processing unit, an application-specific processor, a microcontroller, or any other type of logic-based device. The processing system **206** may also include circuitry that retrieves and executes software **202** from storage system **204**. Processing system **206** can be implemented within a single processing device, but can also be distributed across multiple processing devices or sub-systems that cooperate in executing program instructions.

[0047] The storage system **204** may comprise any storage media, or group of storage media, readable by processing system **206**, and capable of storing software **202**. The storage system **204** can include volatile and non-volatile,

removable and non-removable media implemented in any method or technology for storage of information, such as computer-readable instructions, data structures, program modules, or other data. Storage system **204** can be implemented as a single storage device but may also be implemented across multiple storage devices or sub-systems. Storage system **204** can further include additional elements, such a controller capable of communicating with the processing system **206**.

[0048] Examples of storage media include random access memory, read only memory, optical discs, flash memory, virtual memory, and non-virtual memory, magnetic sets, magnetic tape, magnetic disc storage or other magnetic storage devices, or any other medium which can be used to store the desired information and that may be accessed by an instruction execution system, as well as any combination or variation thereof, or any other type of storage medium. Likewise, the storage media may be housed locally with the processing system **206**, or may be distributed in one or more servers, which may be at multiple locations and networked, such as in cloud computing applications and systems. In some implementations, the storage media can be a non-transitory storage media. In some implementations, at least a portion of the storage media may be transitory.

[0049] The communication interface **208** interfaces between the elements within the computing system **200** and external devices, such as with the controller **22** of each ultrasound transducer and/or a controller for the user interface system **16** and/or display device **17**. In certain embodiments, the communication interface **208** may also be configured to receive information transmitted from the positions sensors **25** in each ultrasound transducer **20**, which may have a separate transmission/receipt means (e.g. wireless) than the ultrasound data **36**, contact indicator **32**, transducer ID **30**, etc.

[0050] FIGS. 9-11 depict various embodiments of the method **80** of fetal ultrasound monitoring, or portions of said method. FIG. 9 provides a flowchart of one embodiment of a method **80** of fetal ultrasound monitoring that begins upon detection of a first ultrasound transducer **20a** to a monitor **12** (step **82**). Instructions are executed at step **84** to determine whether all contact sensors indicate that the first ultrasound transducer **20a** is contacting the patient's abdomen based on the contact indicator **32** supplied by the one or more contact sensors therein. If the contact sensors do not indicate contact, then the system waits for indication of contact, repeating steps **85** and **82**, and no further assessment is made. Once contact is indicated at step **84**, a first heart rate is measured at step **86** based on ultrasound data **36** gathered by the first ultrasound transducer **20a**. Step **88** is then executed to receive a first transducer ID from the first transducer, such as from the identifier unit **23** within the first ultrasound transducer **20a**, as described above. The system also identifies a position of the first transducer **20a** at step **90**, such as based on user input as exemplified herein or by automatic position determination via input from a position sensor **25** in the respective fetal ultrasound transducer **20a**. A first transducer label **41a**, **41b** is then determined at step **92**, which may be based on the position of the first transducer identified at step **90**. A first transducer ID **30** is correlated with the first transducer label at step **94**, and a first heart rate indicator is displayed in correlation with the first transducer label at step **96**. An abdomen image is displayed at step **98** with the transducer icon **50** located thereon at a location that corre-

sponds with the position of the first transducer **20a** on the mother's abdomen **3**, and first transducer label **41a**, **41b** provided therewith.

[0051] In certain embodiments, the system **10** may be further configured to control an illumination device **29** based on the first transducer label **41**. For example, in an embodiment where the illumination device **29** is illuminable in at least two different colors, the system, such as executing the instructions stored as part of the transducer tracking module **14**, may select one of the at least two different illumination colors to correspond with the first transducer label **41**, and may control illumination of the illumination device **29** based thereon. Accordingly, the various fetal ultrasound transducers **20a**, **20b**, **20c** may be interchangeable, and the system may automatically correlate the transducer with a respective fetus and fetal heart rate measurement based on the sensed position of the respective fetal ultrasound transducer **20a**, **20b**, **20c**. The illumination device **29** can then be used to provide a visual indication of which fetus and fetal heart rate measurement that respective fetal ultrasound transducer **20a**, **20b**, **20c** has been assigned to.

[0052] FIG. 10 depicts one embodiment of a method **80** of fetal ultrasound monitoring, and specifically method steps for providing a user interface and receiving user input to identify positions of ultrasound transducers **20** connected to a mother's abdomen. Transducer icons are presented on a user display for user placement at step **100**. For example, the same number of transducer icons **50** may be presented on the display corresponding with the number of fetal ultrasound transducers **20a**, **20b**, **20c** that are connected to the monitor **12** and in contact with the mother's abdomen **3**. User input indicating final placement is received at step **102**, such as selection of the "apply" button shown in the exemplary embodiments depicted at FIGS. 3-7. The position of each transducer icon is determined in an XY-plane (or XYZ-space, if a 3D image) based on the user placement of the transducer icons **50** on the abdomen image **40**. For example, the abdomen image **40** provided on the user interface display **38** may be mapped with an XY-grid that corresponds with the sensor grid of the touch screen—e.g., the center point of each transducer icon **50** may be identified corresponding with the XY-grid of the abdomen image **40**. The transducer position for each fetal ultrasound transducer **20a**, **20b**, **20c** is then identified based on the placement of the transducer icons on the abdomen image.

[0053] In certain embodiments, the system **10**, such as by executing instructions comprising the transducer tracking module **14**, may then automatically determine the transducer labels **41a**, **42a**, **43a** according to the identified position for each of the fetal ultrasound transducers **20a**, **20b**, **20c** where the respective contact sensors **27** indicate contact with the mother's abdomen **3**. For example, the lowest positioned transducer may be assigned the first alphanumeric transducer label **41a**, and so on as described above.

[0054] In other embodiments, the certain or all transducer labels may be assigned based on user input. In the example of FIG. 10, the transducer labels are presented on the display at step **108** for user placement, such as a number of transducer labels corresponding with the number of fetal ultrasound transducers **20** that are connected to the monitor **12** and in contact with the mother's abdomen. Once the system receives user input at step **110** indicating final

placement, the transducer labels are correlated accordingly with the transducer IDs and positions of the fetal ultrasound transducers **20** accordingly.

[0055] This written description uses examples to disclose the invention, including the best mode, and also to enable any person skilled in the art to make and use the invention. Certain terms have been used for brevity, clarity and understanding. No unnecessary limitations are to be inferred therefrom beyond the requirement of the prior art because such terms are used for descriptive purposes only and are intended to be broadly construed. The patentable scope of the invention is defined by the claims, and may include other examples that occur to those skilled in the art. Such other examples are intended to be within the scope of the claims if they have features or structural elements that do not differ from the literal language of the claims, or if they include equivalent features or structural elements with insubstantial differences from the literal languages of the claims.

We claim:

1. A fetal ultrasound system comprising:

- one or more fetal ultrasound transducers, each having:
  - an ultrasound device configured to generate sound waves in the ultrasonic range and convert reflected sound waves into ultrasound data for detection of a fetal heart beat;
  - a contact sensor configured to sense contact with a mother's abdomen and generate a contact indicator;
  - a transducer identifier unit that communicates a transducer ID;
- a monitor configured to receive the ultrasound data, the contact indicator, and the transducer ID from the one or more ultrasound transducers, and comprising a transducer tracking module executable on a processor to:
  - generate a transducer label for each of the one or more fetal ultrasound transducers;
  - associate the transducer ID for each fetal ultrasound transducer with the respective transducer label;
  - determine a fetal heart rate based on the ultrasound data and generate a corresponding heart rate indicator;
  - identify a position of each of the one or more fetal ultrasound transducers;
  - generate an abdomen image with the transducer labels positioned thereon based on the position of each of the one or more fetal ultrasound transducers; and
- a display device configured to display the abdomen image with the transducer label for each of the one or more fetal ultrasound transducers, and to display the fetal heart rate indicator in association with the respective transducer label.

2. The system of claim 1, further comprising a position sensor in the at least one fetal ultrasound transducer, wherein the position sensor is configured to measure position information with respect to at least a two-dimensional plane, and wherein the position of each of the one or more fetal ultrasound transducers is identified based on the position information.

3. The system of claim 2, wherein the transducer tracking module is further executable to calculate the position of each of the fetal ultrasound transducers connected to the monitor based on the position information, and to automatically generate the abdomen image with the transducer labels positioned thereon based on the positions of the fetal ultrasound transducers.

4. The system of claim 3, wherein each position sensor includes an inertial measurement unit providing inertial position information and an electromagnetic receiver/transmitter providing relative position information with respect to at least a second fetal ultrasound transducer.

5. The system of claim 1, wherein the contact sensor includes two capacitive sensors positioned on opposing ends of a contact surface of the fetal ultrasound transducer, and wherein the transducer tracking module is further executable to determine that the respective fetal ultrasound transducer is contacting the mother's abdomen only when the contact indicator from both capacitive sensors is less than a threshold capacitance.

6. The system of claim 5, wherein the transducer tracking module is further executable to automatically determine the fetal heart rate and display the fetal heart rate indicator in association with the transducer label only when both of the capacitive sensors detect less than the threshold capacitance.

7. The system of claim 5, wherein the transducer tracking module is further executable to generate a probe off alert in association with the transducer label for the respective fetal ultrasound transducer when one of the capacitive sensors detect greater than the threshold capacitance.

8. The system of claim 1, wherein each of the one or more fetal ultrasound transducers further comprises a colored LED that is a different color than those of all other ultrasound transducers connected to the monitor, and wherein the transducer label for that fetal ultrasound transducer includes a color indicator the same color as the respective colored LED.

9. The system of claim 1, wherein the system further includes a user interface configured to receive user input placing the transducer labels at a location on the abdomen image corresponding to a location of the fetal ultrasound transducer on the mother's abdomen; and

wherein the transducer tracking module is further executable to identify the position of each of the one or more fetal ultrasound transducers connected to the monitor based on the user input.

10. The system of claim 1, wherein the transducer tracking module is further executable to associate the transducer ID for each fetal ultrasound transducer with the transducer label based on the position of the respective fetal ultrasound transducer.

11. A method of fetal ultrasound monitoring, the method comprising:

detecting contact of a first ultrasound transducer with a mother's abdomen based on input from a contact sensor in the first ultrasound transducer;

receiving a first transducer ID from the first ultrasound transducer;

correlating the first transducer ID with a first transducer label;

measuring a first heart rate based on output of an ultrasound device in the first ultrasound transducer;

displaying a first heart rate indicator on a display device in association with the first transducer label;

identifying a first position of the first ultrasound transducer in at least a two-dimensional plane; and

displaying the first transducer label on an abdomen image based on the first position.

12. The method of claim 11, further comprising:

detecting connection of a second ultrasound transducer to the mother's abdomen based on input from a sensor in the second ultrasound transducer;

receiving a second transducer ID from the second ultrasound transducer;

correlating the second transducer ID with a second transducer label;

measuring a second heart rate based on output of an ultrasound device in the second ultrasound transducer;

displaying a second heart rate indicator on a display device in association with the second transducer label;

identifying a second position of the second ultrasound transducer in the two-dimensional plane; and

displaying the second transducer label on the abdomen image based on the second position.

13. The method of claim 12, wherein the step of identifying the first position includes measuring first position information of the first fetal ultrasound transducer with a position sensor in the first fetal ultrasound transducer, and determining the first position with respect to the at least the two dimensional plane based on at least the first position information.

14. The method of claim 13, wherein the step of identifying the second position includes measuring second position information of the second fetal ultrasound transducer with a position sensor in the second fetal ultrasound transducer, and determining the second position with respect to the two dimensional plane based on at least the first position information and the second position information.

15. The method of claim 14, further comprising automatically generating the abdomen image with the first transducer label and the second transducer label positioned thereon based on the first position and the second position.

16. The method of claim 14, wherein the transducer tracking module is further executable to associate the transducer ID for each of the first and second fetal ultrasound transducers with the respective transducer label based on the first position and the second position.

17. The method of claim 12, wherein the first fetal ultrasound transducer includes a first illumination device illuminable in at least two different colors, the second fetal ultrasound transducer includes a second illumination device illuminable in the at least two different colors, and wherein the method further comprises:

controlling the first illumination device to illuminate in one of the at least two different colors based on the first transducer label; and

controlling the second illumination device to illuminate in a different one of the at least two different colors based on the second transducer label.

18. The method of claim 11, wherein the first fetal ultrasound transducer includes at least one capacitive sensor, the method further comprising:

detecting that a capacitance measured by the capacitive sensor is greater than the threshold capacitance; and

generating a probe off alert in association with the first transducer label for the respective fetal ultrasound transducer.

19. The method of claim 18, wherein the step of detecting connection of the first ultrasound transducer to the mother's abdomen includes determining that all of the at least one capacitive sensors in the first fetal ultrasound transducer measure less than a threshold capacitance.

**20.** The method of claim **11**, further comprising:  
presenting a user interface configured to receive user  
input placing the first the transducer label at a location  
on the abdomen image corresponding to a location of  
the first fetal ultrasound transducer on the mother's  
abdomen;  
wherein the first position is identified based on the user  
input.

\* \* \* \* \*

专利名称(译)	胎儿超声监测方法和系统		
公开(公告)号	<a href="#">US20190223832A1</a>	公开(公告)日	2019-07-25
申请号	US15/877003	申请日	2018-01-22
[标]申请(专利权)人(译)	通用电气公司		
申请(专利权)人(译)	通用电气公司		
当前申请(专利权)人(译)	通用电气公司		
[标]发明人	BOGINENI KIRAN KUMAR JAISWAL RAVI MEHTA JAY		
发明人	BOGINENI, KIRAN KUMAR JAISWAL, RAVI GADGIL, SHRUTI MEHTA, JAY		
IPC分类号	A61B8/08 A61B5/00 A61B5/024		
CPC分类号	A61B8/0866 A61B5/4362 A61B5/02411 A61B8/02 A61B8/4281 A61B5/0444 A61B2503/02 A61B8/4483		
外部链接	<a href="#">Espacenet</a> <a href="#">USPTO</a>		

摘要(译)

胎儿超声监测的方法包括基于来自第一超声换能器中的接触传感器的输入检测第一超声换能器与母亲腹部的接触。从第一超声换能器接收第一换能器ID，然后将第一换能器ID与第一换能器标签相关联。基于第一超声换能器中的超声设备的输出来测量第一心率，并且相应地显示心率指示器。在二维平面中识别第一超声换能器的位置，并且基于第一位置在腹部图像上显示第一换能器标签。

