



US 2018000315A1

(19) **United States**

(12) **Patent Application Publication**
CHRISTENSEN et al.

(10) **Pub. No.: US 2018/0000315 A1**
(43) **Pub. Date: Jan. 4, 2018**

(54) **ARTICULATION ACTIVATION WIRE
STRESS RELIEF FOR AN ULTRASOUND
IMAGING PROBE**

A61B 1/005 (2006.01)
A61B 8/00 (2006.01)

(52) **U.S. Cl.**
CPC *A61B 1/008* (2013.01); *A61B 8/445*
(2013.01); *A61B 1/00006* (2013.01); *A61B*
1/0052 (2013.01); *A61B 1/0057* (2013.01)

(71) Applicant: **B-K Medical Aps**, Herlev (DK)

(72) Inventors: **Bjarne Lasse CHRISTENSEN**, Koege
(DK); **Niels-Christian LL Sasady**,
Frederiksberg (DK)

(57) **ABSTRACT**

A probe includes an articulating member with at least two vertebrae elements sequentially arranged along a long axis of the elongate ultrasound imaging probe. The articulating member includes pivots located between the at least two vertebrae elements. The pivots are disposed off-center relative to the at least two vertebrae elements. The pivots are spatially oriented to provide a pivot point for a different articulation direction of a vertebra element. The probe further includes a plurality of guides, including at least one guide for each of the respective different pivot directions. The probe further includes an actuator with a set of controls, each control configured to actuate a different pair of the plurality of guides for controlling opposing articulation directions, wherein the actuator reduces stress induced on at least one of a pushed guide or a non-activated guide, wherein the stress is induced in response to the actuator pulling a guide.

(73) Assignee: **B-K Medical Aps**, Herlev (DK)

(21) Appl. No.: **15/543,651**

(22) PCT Filed: **Jan. 16, 2015**

(86) PCT No.: **PCT/IB2015/050348**

§ 371 (c)(1),

(2) Date: **Jul. 14, 2017**

Publication Classification

(51) **Int. Cl.**
A61B 1/008 (2006.01)
A61B 1/00 (2006.01)

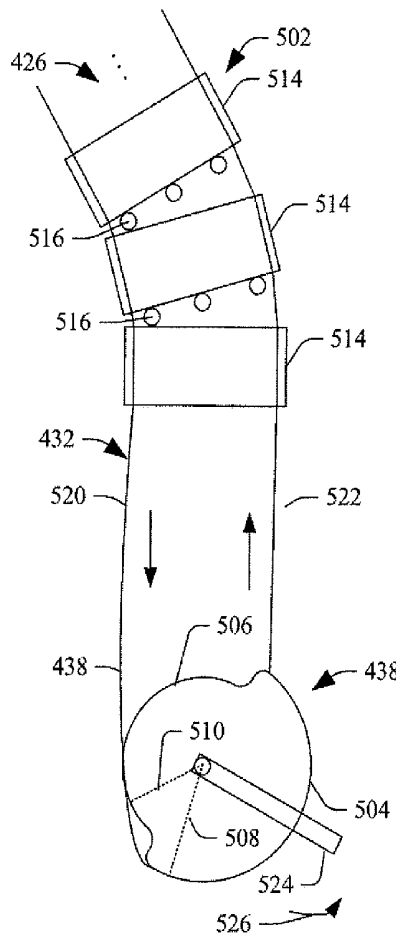

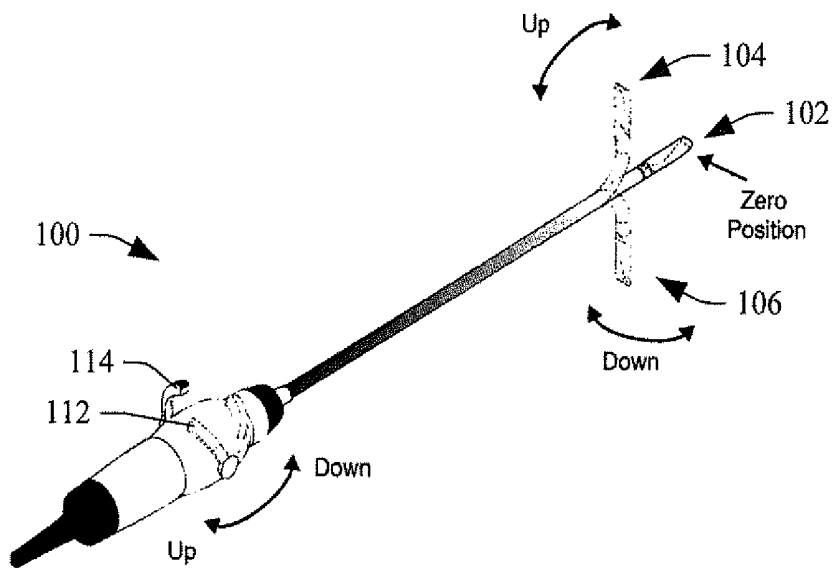

FIGURE 1A
(PRIOR ART)

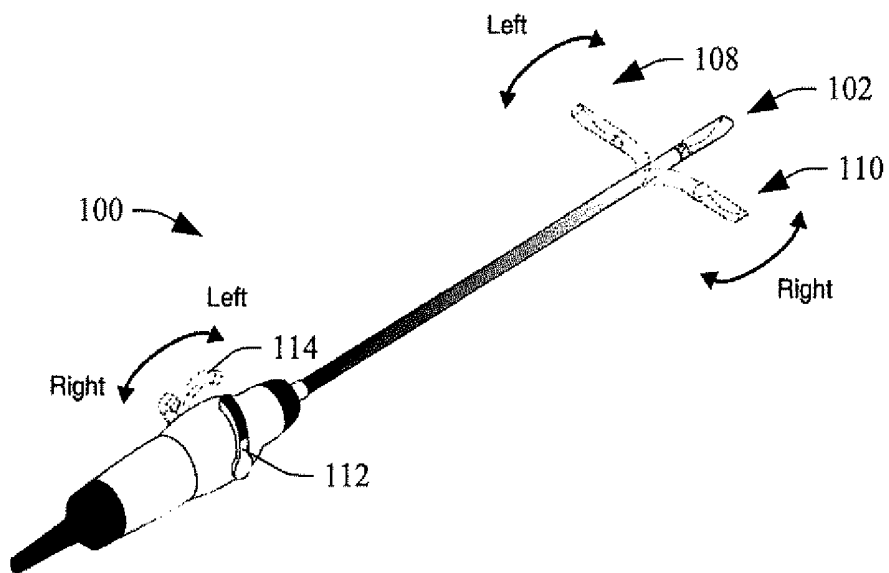

FIGURE 1B
(PRIOR ART)

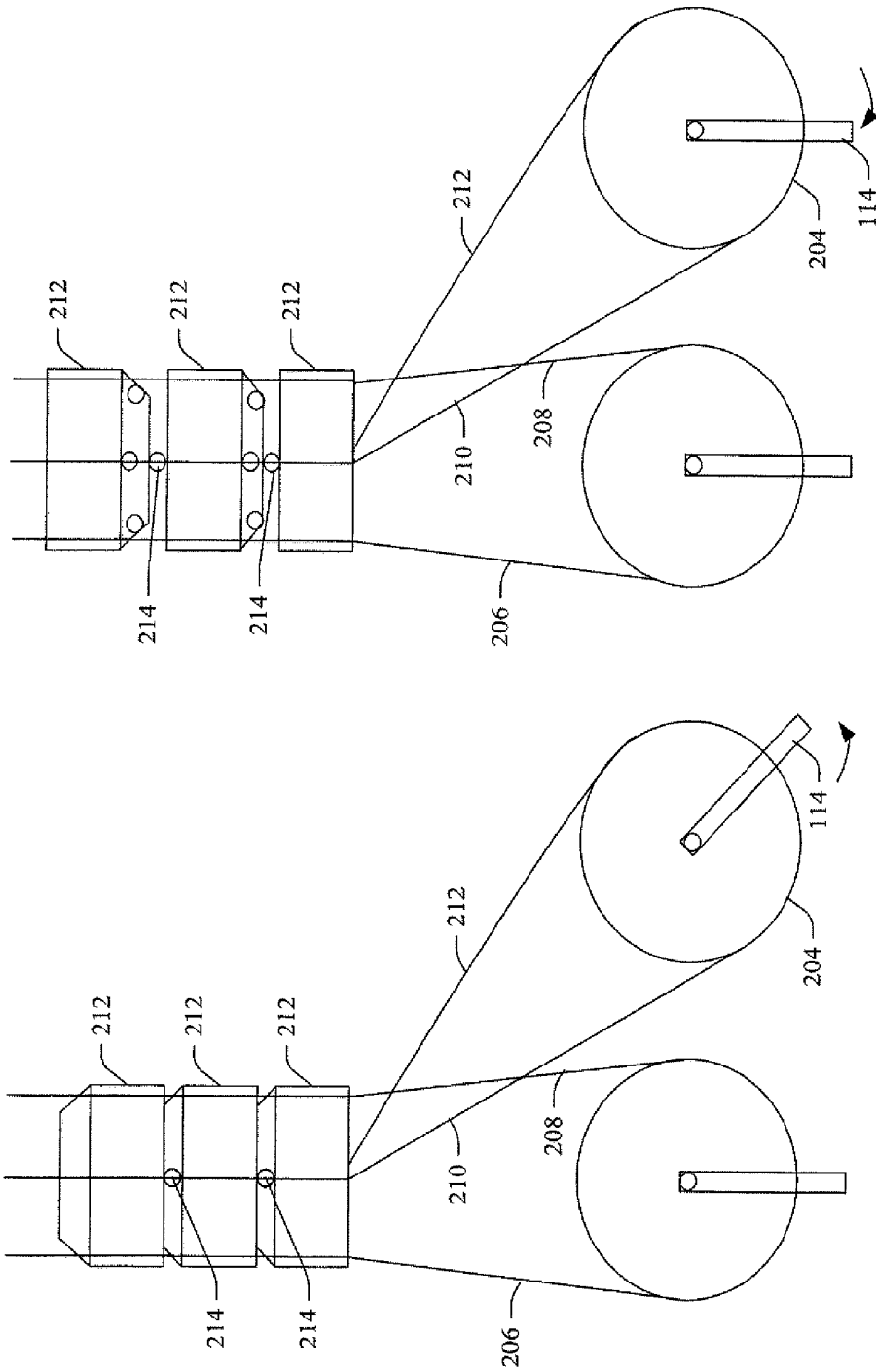

FIGURE 3B
(PRIOR ART)

FIGURE 3A
(PRIOR ART)

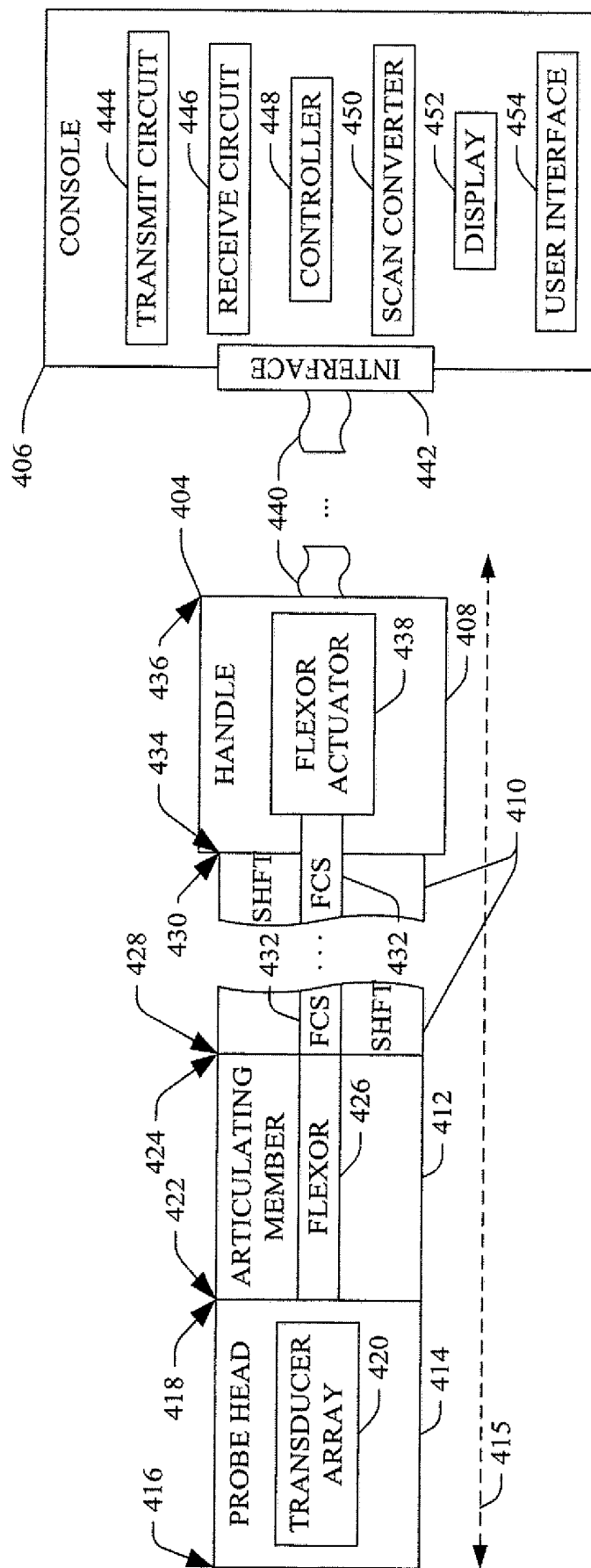

FIGURE 4

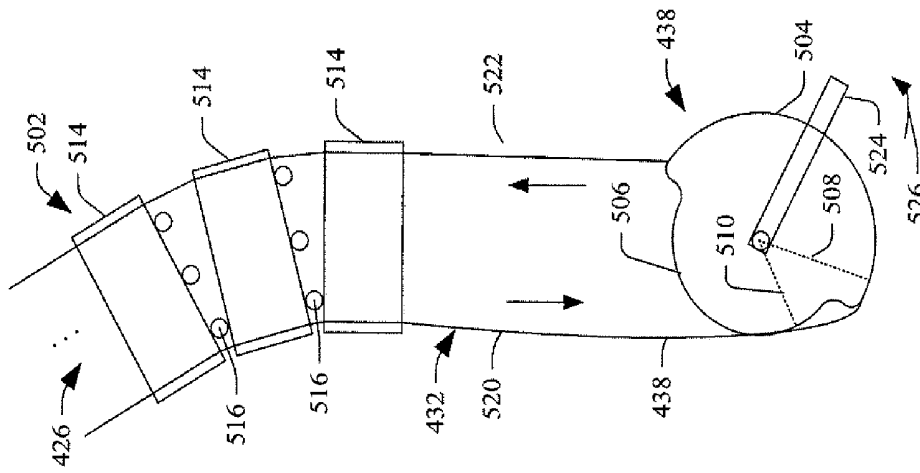

FIGURE 5B

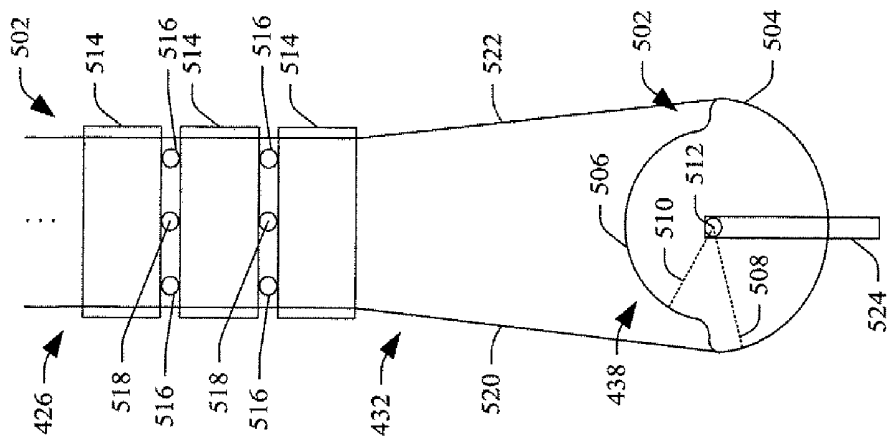

FIGURE 5A

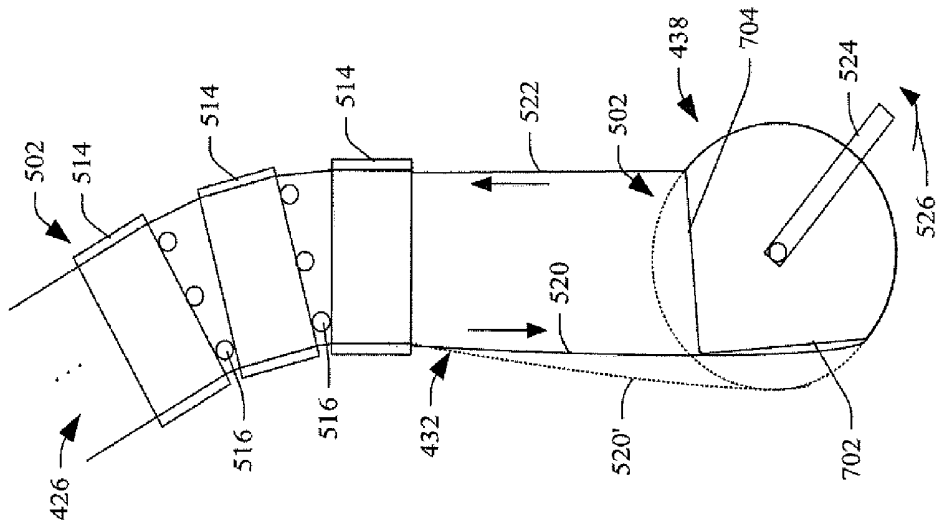

FIGURE 7

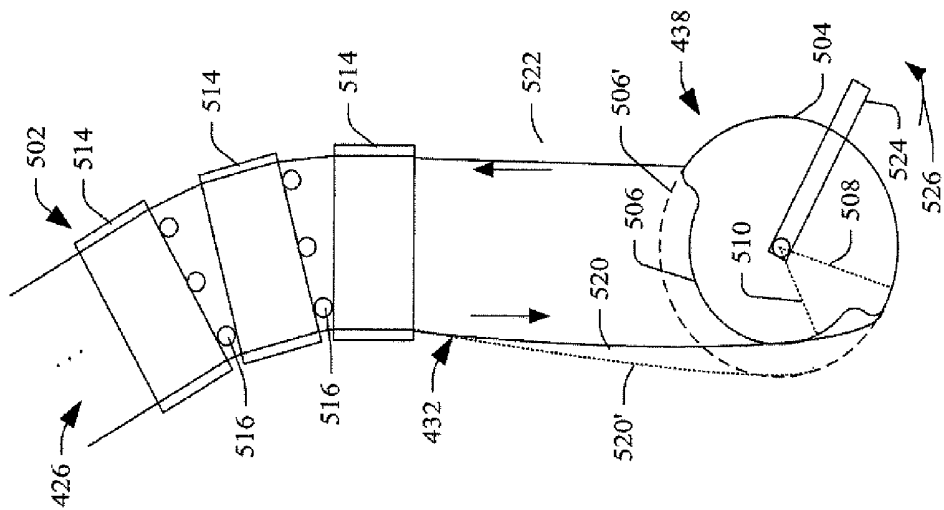

FIGURE 5C

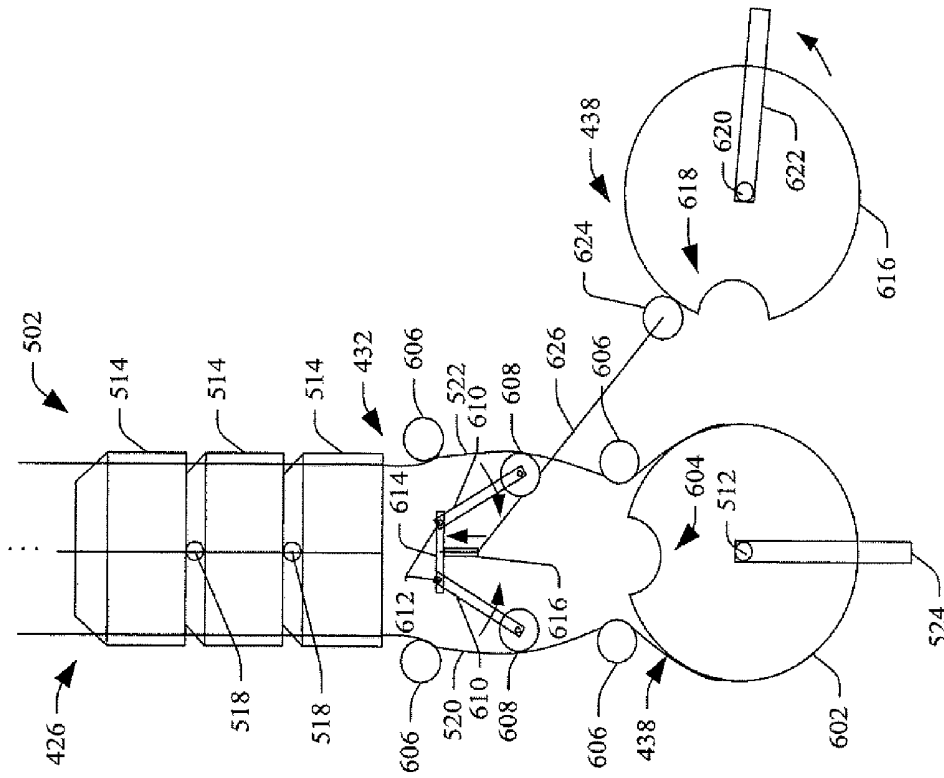

FIGURE 6B

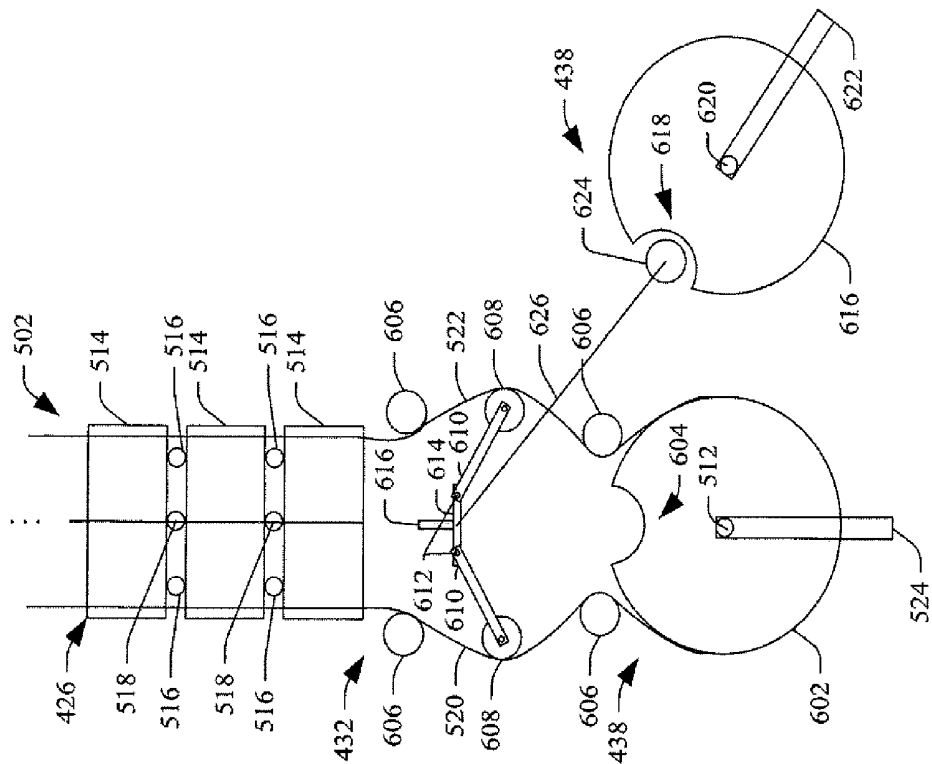

FIGURE 6A

**ARTICULATION ACTIVATION WIRE
STRESS RELIEF FOR AN ULTRASOUND
IMAGING PROBE**

TECHNICAL FIELD

[0001] The following generally relates to ultrasound (US) imaging and more particularly to articulation activation wire stress relief for an ultrasound imaging probe.

BACKGROUND

[0002] There are at least two different types of ultrasound imaging probes—flexible and rigid. Flexible ultrasound probes include an articulating portion that is controllably articulated to move the end of the probe head and the transducer array through an angle of, e.g., up to 180° degrees in one to four planes. FIGS. 1A and 1B show an example of a flexible probe **100**; namely, a laparoscopic transducer type 8666, which is a product of BK-Medical ApS, a company of Herlev, Denmark. In FIG. 1A, an articulating portion **102** is configured to articulate to an up position **104** or a down position **106**. A lever **112** controls up/down articulation. In FIG. 1B, the articulating portion **102** is further configured to articulate to a left position **108** or a right position **110**. A lever **114** controls left/right articulation. Generally, either the first lever **112** or the second lever **114** is employed during an examination, but not concurrently both of the levers **112** and **114**.

[0003] FIG. 2A shows the lever **112** attached to a cam **202** and the lever **114** attached to a cam **204**. A first wire **206** is connected between a first side of the cam **202** and a first side of the articulating portion **102**, and a second wire **208** is connected between a second opposing side of the cam **202** and a second opposing side of the articulating portion **102**. A third wire **210** is connected between a first side of the cam **204** and a third side of the articulating portion **102**, and a fourth wire **212** is connected between a second side of the cam **204** and a fourth side of the articulating portion **102**. The lever **112** rotates the cam **202**, and the lever **114** rotates the cam **204**. Rotating one of the cams **202** or **204** causes the corresponding wires to push on one side and pull on the opposing side of the articulating portion **102**, which causes the articulating portion **102** to articulate. The articulating portion **102** includes a plurality of vertebrae **213** separated by pivots **214**. Between neighboring vertebrae **213**, a first pair of pivots **214** is for left/right articulation and a second pair of pivots **214** is for up/down articulation. The pivots **214** are located off center with respect to the articulating portion **102**.

[0004] In FIG. 2B, the lever **112** is rotated counter-clockwise, which pulls on the wire **206** and pushes on the wire **208** resulting in left articulation. Since the pivots **214** are off center, the pull and push lengths of the wires **206** and **208** are not the same. That is, a push length is longer than a pull length. However, the cam **202** releases only a same length of wire, which is the pull length. As a consequence, a stress is induced in the pushed wire. Rotating the lever **112** clockwise, the lever **114** counter-clockwise, or the lever **114** clockwise likewise induces a stress in the pushed wire. FIGS. 3A and 3B show down and up articulation with the lever **114**. Furthermore, both of the wires of the non-activated lever will be likewise stressed. This can be seen in FIGS. 2B (wires **210** and **212**) and FIGS. 3A and 3B (wires **206** and **208**). One approach to mitigate these stresses are to

include springs in the wires. Unfortunately, with such an approach, the springs introduce slack in the wires, causing a delay between the articulation expected by the user and the actual articulation.

SUMMARY

[0005] Aspects of the application address the above matters, and others.

[0006] In one aspect, an elongate ultrasound imaging probe includes an articulating member. The articulating member includes at least two vertebrae elements sequentially arranged along a long axis of the elongate ultrasound imaging probe. The articulating member further includes a plurality of pivots located between the at least two vertebrae elements. Each of the plurality of pivots is disposed off-center relative to the at least two vertebrae elements. Each of the plurality of pivots is spatially oriented to provide a pivot point for a different articulation direction of a set of different of articulation directions of a vertebra element of the plurality of vertebrae elements. The probe further includes a plurality of guides, including at least one guide for each of the respective different pivot directions. An actuator with a set of controls, each control configured to actuate a different pair of the plurality of guides for controlling opposing articulation directions, wherein the actuator reduces stress induced on at least one of a pushed guide or a non-activated guide, wherein the stress is induced in response to the actuator pulling a guide.

[0007] In another aspect, an elongate ultrasound imaging probe includes a flexor configured to flex a tip of the probe, where the tip of the probe houses a transducer array, a flexor control system configured to control the flexor to flex the tip in one of a plurality of different directions through pulling and pushing on guides affixed to the flexor, and a flexor actuator configured to actuate the flexor control system to selectively pull and push on the guides.

[0008] In another aspect, an ultrasound imaging system includes a probe and a console. The probe includes a probe head with a transducer array, a shaft, an articulating member disposed between the probe head and the shaft, an articulating member actuator configured to control the articulating member through guide wires, wherein the articulating member reduces stress in the guide wires through a structural elements that slack off at least one of a pushed guide wire or a non-activated guide wire in response to at least one pulled guide wire, and a console interface. The console includes ultrasound imaging components and a probe interface. The console and probe interfaces are complementary interfaces, providing an electrical communications path between the probe and the console.

[0009] Those skilled in the art will recognize still other aspects of the present application upon reading and understanding the attached description.

BRIEF DESCRIPTION OF THE DRAWINGS

[0010] The application is illustrated by way of example and not limitation in the figures of the accompanying drawings, in which like references indicate similar elements and in which:

[0011] FIG. 1A illustrates up/down articulation of a probe head of a prior art ultrasound imaging probe;

[0012] FIG. 1B illustrates left/right articulation of the probe head of the prior art ultrasound imaging probe of FIG. 1A;

[0013] FIG. 2A illustrates example control of the articulation of the probe of FIGS. 1A and 2B;

[0014] FIG. 2B illustrates left articulation and stress induced on the pushed wire and the non-actuated wires of the probe of FIGS. 1A and 2B;

[0015] FIG. 3A illustrates down articulation and stress induced on the pushed wire and the non-actuated wires of the probe of FIGS. 1A and 2B;

[0016] FIG. 3B illustrates up articulation and stress induced on the pushed wire and the non-actuated wires of the probe of FIGS. 1A and 2B;

[0017] FIG. 4 schematically illustrates an example ultrasound imaging system with probe with an articulation sub-system.

[0018] FIG. 5A illustrates an example of the articulation sub-system.

[0019] FIG. 5B illustrates the example of the articulation sub-system in use.

[0020] FIG. 5C illustrates the example of the articulation sub-system in connection with prior art.

[0021] FIG. 6A illustrates another example of the articulation sub-system.

[0022] FIG. 6B illustrates the example articulation sub-system of FIG. 6A in use.

DETAILED DESCRIPTION

[0023] FIG. 4 illustrates an imaging system 402 such as ultrasound imaging system. The imaging system 402 includes an elongate ultrasound probe 404 and a console 406. The elongate ultrasound probe 404 includes a handle 408, a shaft (SHFT) 410, an articulating member 412, and a probe head 414. The handle 408, the shaft 410, the articulating member 412 and the probe head 414 respectively are arranged with respect to each along a longitudinal axis 415 of the elongate ultrasound probe 404.

[0024] The probe head 414 includes a first end region 416 and a second end region 418. In the illustrated embodiment, the probe head 414 also includes a transducer array 420. In another embodiment, the probe head 414 can also include a biopsy region. The first end region 416 includes the end of the probe 404. The second end region 418 is affixed to the articulating member 412. The transducer array 420 includes a one or two dimensional array transducer elements. Suitable configurations include, but are not limited to, linear, curved (e.g., convex), and phased arrays. The transducer array 420 is configured to acquire data for A-mode, B-mode, etc. acquisitions, individually and in combination with color flow, Doppler flow, etc.

[0025] The articulating member 412 includes a first end region 422, a second end region 424 and a flexor 426. The first end region 416 is affixed to the second end region 418 of the probe head 414. The second end region 424 is affixed to the shaft 410. The flexor 426 extends along the longitudinal axis 415. The flexor 426 is configured to flex the articulating member 412 to various positions, e.g., in one to four planes through angles of up to ninety (90) degrees or more. Examples of suitable positions include up, down, left, right and/or other positions. As described in greater detail below, in one instance, the flexor includes a plurality of vertebrae with pivots there between.

[0026] The shaft 410 includes a first end region 428, a second end region 430, and at least a first portion of the flexor control system (FCS) 432. The first end region 428 is affixed to the second end region 424 of the articulating member 412. The second end region 430 is affixed to the handle 408. The flexor control system 426 extends along the longitudinal axis 415. The flexor control system 426 is configured to push and pull on the flexor 426 to flex the articulating member 412 for up/down and left/right articulation. As described in greater detail below, in one instance, the flexor control system 432 includes a plurality of guides such as wires that pull and push on the vertebrae, pivoting them on the pivots.

[0027] The handle 408 includes a first end region 434, a second end region 436, at least a second portion of the flexor control system 432, a flexor actuator 438, and an interface 440. The first end region 434 is affixed to the second end region 430 of the shaft 410. The second end region 436 represents the other opposing end of the probe 404. The flexor actuator 438 is configured to control the flexor control system 432 to control the flexing of the flexor 426. In one embodiment, the flexor actuator 438 is as shown in FIGS. 1A and 1B. In another embodiment, the flexor actuator 438 includes a ratchet mechanism on each activation wheel. The ratchet mechanism can be switched on/off in the handle 408. In yet another embodiment, the flexor actuator 438 includes an electrical based on/off (and copy) button (electrically) on the handle 408. The interface 440 is configured for connection with a complementary interface of an ultrasound console.

[0028] As described in greater detail below, the flexor actuator 438 is configured to mitigate stress induced in the flexor 426 and the flexor control system 432 by actuation of the flexor actuator 438. In one instance, this includes stress induced in the pushed wire for up/down articulation, or stress induced in the pushed wire for left/right articulation. In another instance, this includes stress induced in the non-actuated wires. In yet another instance, this includes both the stress induced in the pushed wire and the stress induced in the non-actuated wires.

[0029] It is to be appreciated that the probe 404 can be used for laparoscopic, endoscopic, and/or other applications, and can be used to assist personnel, for example, with an interventional procedure such as a liver, gall bladder, tumor biopsy, etc., guide personnel, for example, with RF ablation, chemical injection, etc. and/or otherwise. As shown, the probe 404 is employed with the console 406. In other embodiments, the probe 404 can be employed with other consoles.

[0030] The console 406 includes an interface 442. The interface 442 is complementary to the interface 440 of the probe 404. In one instance, the interface 440 includes a cable with an electro-mechanical connector and the interface 442 includes an electro-mechanical connector. The interfaces 440 and 442 are configured to mechanically engage each other and establish electrical communication there between, e.g., through pins and sockets and/or otherwise. Alternatively, the interfaces 440 and 442 are wireless interfaces.

[0031] The console 406 includes a transmit circuit 444 that controls the phasing and/or time of actuation of the individual elements of the transducer array 420, which allows for steering and/or focusing the transmitted beam from predetermined origins along the array and at predetermined angles.

[0032] The console 406 further includes a receive circuit 446 that receives signals indicative of the echoes received by the transducer array 420. The receive circuit 446 can beam-form (e.g., delays and sums) the echoes into a sequence of focused, coherent echo samples along focused scanlines of a scanplane, and/or otherwise process the echoes.

[0033] The console 406 further includes a controller 448 that controls the transmit circuit 444 and/or the receive circuit 446. Such control may include, but is not limited to, controlling the frame rate, number of scan line groups, transmit angles, transmit energies, transmit frequencies, transmit and/or receive delays, etc.

[0034] The console 406 further includes a scan converter 450 that scan converts the frames of data to generate data for display, for example, by converting the data to the coordinate system of the display. This may include changing the vertical and/or horizontal scan frequency of signal based on the display. Furthermore, the scan converter 450 can be configured to employ analog and/or digital scan converting techniques.

[0035] The console 406 further includes a display 452 that visually presents the rendered data. The display 452 can be integrated in the console 406 or separate therefrom and in electrical communication therewith via a wired and/or wireless connection.

[0036] The console 406 further includes a user interface 454 that includes input and/or output devices for interacting with the controller 448 to select a data acquisition mode (e.g., B-mode), initiate scanning, etc. The user interface 454 may include various controls such as buttons, knobs, a keypad, a touch screen, etc. The user interface 454 may also include various types of visual (e.g., LCD, LED, etc.) and/or audible displays.

[0037] It is to be understood that the relative size, shape and position of the components of the system 402 are provided for explanatory purposes and are not limiting. In other embodiments, at least one of the size, shape and position of at least one of the components is different.

[0038] FIG. 5A schematically illustrates an example of the flexor actuator 438, the flexor control system 432, and the flexor 426.

[0039] This example is configured to compensate for the difference in the push and pull length of the guides. For sake of clarity and brevity, only one of the up/down or the left/right articulation sub-systems is shown. However, it is to be understood that the up/down or the left/right articulation sub-systems include the same components, with one controlling up/down articulation and the other controlling left/right articulation.

[0040] The flexor actuator 438 includes a cam 502. In this example, the cam 502 is disc shaped with two, or first and second half-circles 504 and 506. The first half circle 504 has a first radius 508, and the second half circle 506 has a second radius 510. The first radius 508 is larger than the second radius 510. The cam 502 is rotatably affixed at a rotation axis 512 and is configured to rotate about the rotation axis 512.

[0041] The flexor 426 includes a plurality of vertebrae 514. Adjacent pairs of the plurality of vertebrae 514 have two pairs of pivots disposed there between. A first pair of pivots 516 is for left/right (or up/down) articulation. A second pair of pivots 518 (one is behind the other) is for the up/down (or left/right) articulation. The pivots 516 and 518 are all located off-center, with the pivots 518 in a direction transverse or perpendicular to the pivots 516.

[0042] The flexor control system 432 includes guides (e.g., wires, strings, cables, or the like) 520 and 522. The guide 520 is connected at a perimeter of one of the ends of the larger half circle 504 at a location where the radius transitions from the larger radius 508 to the smaller radius 510. The guide 522 is connected at a perimeter of the other end of the larger half circle 504, also at a location where the radius transitions from the larger radius 508 to the smaller radius 510. The guides 520 and 522 respectively route through the vertebrae 514, outside of the pivots 516 and 518.

[0043] The flexor actuator 438 further includes a lever 524. The lever 524 is stationarily affixed to the cam 502. The lever 524 represents the lever 512 or 514 of FIG. 1. Rotating the lever 512 or 514 rotates the cam 502. Such rotation may include clockwise and/or counter-clockwise rotation.

[0044] The plurality of vertebrae 514 are aligned parallel to each other. The cam 502 is oriented so that neither guide 520 or 522 is pulled or pushed. The second half circle 506 faces the plurality of vertebrae 514 and the first half circle 504 faces away from the plurality of vertebrae 514. In this configuration, the articulating member 412 (FIG. 4) and the probe head 414 (FIG. 4) extend straight along the longitudinal axis 415 (FIG. 4), e.g., as shown in FIG. 4, and not articulated.

[0045] In FIG. 5B, the lever 524 is rotated in a first or counter-clockwise direction 526. This rotates the cam 502 in the first direction 526. This causes the guide 520 to pull on the plurality of vertebrae 514 on one side of the articulating member 412, and the guide 522 to push on the plurality of vertebrae 514 on the other side of the articulating member 412. In this direction, the plurality of vertebrae 514 pivots on the pivots 516 on the one side, which causes the plurality of vertebrae 514 to separate on the other side.

[0046] As shown in FIG. 5C, the smaller radius 510 of the half circle 506 slacks off the pull guide for the same rotational movement, relative to a configuration in which the cam 502 has only the larger radius 508, which is shown in FIG. 5C in connection with a guide 520' and a second half circle 506'. In FIG. 5C, the guide 520' follows a perimeter of the second half circle 506', whereas the guide 520 follows the perimeter of the second half circle 506. This slacking off of the pull guide reduces the stress on the pushed guide. Furthermore, unlike a configuration in which the guides 520 and 522 include springs, the probe head 414 articulates when expected to articulate by the user.

[0047] In general, the cam 502 can have any shape just as long as it provides a guide travel difference between the pull and push sides to reduce the push guide stress. For example, in another embodiment, rather than include the smaller radius 510 with side 506, the cam 502 includes angled sides 702 and 704 as shown in FIG. 7. Other configurations are also included herein.

[0048] FIG. 6A schematically illustrates another example of the flexor actuator 438.

[0049] This example is configured to compensate for the stress induced in the non-actuated wires. For sake of clarity and brevity, details are shown for only one of the lever/cam/guide sub-systems. However, it is to be understood that both lever/cam/guide sub-systems include the same components and operate the same, with one controlling up/down articulation and the other controlling left/right articulation.

[0050] In this example, the flexor actuator 438 for the left/right articulation includes a circular shaped cam 602 with a sub-cam 604. The cam 602 is rotatably affixed at the

rotation axis **512** and is configured to rotate about the rotation axis **512**. The flexor **426** for the left/right articulation is substantially similar to that described in FIGS. **5A** and **5B** and thus will not be described in detail again.

[0051] The flexor control system **432** includes a plurality of fixed rotating wheels **606** and a plurality of pivoting rotating wheels **608**. The wheels **606** and **608** are all configured to rotate. The wheels **606** are stationarily fixed. The wheels **608** are attached to free ends of pivot members **610**, which pivot about pivot points **612**. The pivot points **612** are disposed on a translating member **614**, which is configured to translate along a rail **616** between the flexor **426** and the cam **524**.

[0052] The flexor actuator **438** for the up/down articulation includes a similar circular shaped cam **616** with a sub-cam **618**. The cam **616** is rotatably affixed at a rotation axis **620** and is configured to rotate about the rotation axis **620**. A lever **622** is attached to the cam **616** and configured to rotate the cam **616**. The flexor **426** for the up/down articulation is also substantially similar to that described in FIGS. **5A** and **5B** and thus will not be described in detail again.

[0053] The sub-cam **618** supports a member **624** when the lever **622** is position for no up/down articulation. A translation arm (push) **626** is affixed at one end to the member **624**. The member **624** is movable, e.g., on a track which defines a range of movement. When the cam **616** is turned the member **624** moves up the sub-cam **618** and pushes with the translation arm **626** the translating member **614**, which causes the pivot members **610** to pivot about the pivot points **612**, which will collapse the wheels **608**, reducing the stress in the wires **520/522**, as described in greater detail next.

[0054] In FIG. **6B**, the lever **622** is rotated counter-clockwise. This causes down articulation in this example. The member **624** rolls out of the sub-cam **618** and onto the perimeter of the cam **616**. As a consequence, the wire **626** moves towards the wheel **628**, allowing the translating member **614** to translate towards the articulation member **412**. Translation of the translating member **614** results in the pivoting members **610** pivoting towards each other. Such pivoting slacks off the guides **520** and **522** for the left/right articulation.

[0055] In one instance, this mitigates the stress induced on the guides **520** and **522** for the left/right articulation due to the down articulation. The same results when rotating in the opposite direction for up articulation. That is, the translating member **614** will translate, slacking off the guides **520** and **522** for the left/right articulation, mitigating the stress induced on the guides **520** and **522** due to the up articulation. When operating the lever **524**, the corresponding translating member will translate, slacking off the guides and for the up/down articulation, mitigating the stress induced on these guides due to the left and right articulation.

[0056] Another embodiment combines the configurations of FIGS. **5A** or **7** and **6A**. For example, with the combined configurations, the embodiment includes two cams, **506** and **616**, with a sub-cam on top of each other, fixed to each other. Other combinations are also contemplated herein.

[0057] The application has been described with reference to various embodiments. Modifications and alterations will occur to others upon reading the application. It is intended that the invention be construed as including all such modi-

fications and alterations, including insofar as they come within the scope of the appended claims and the equivalents thereof.

What is claimed is:

1. An elongate ultrasound imaging probe, comprising:
 - an articulating member, including:
 - at least two vertebrae elements sequentially arranged along a long axis of the elongate ultrasound imaging probe; and
 - a plurality of pivots located between the at least two vertebrae elements, wherein each of the plurality of pivots is disposed off-center relative to the at least two vertebrae elements, and each of the plurality of pivots is spatially oriented to provide a pivot point for a different articulation direction of a set of different of articulation directions of a vertebra element of the plurality of vertebrae elements;
 - a plurality of guides, including at least one guide for each of the respective different pivot directions; and
 - an actuator with a set of controls, each control configured to actuate a different pair of the plurality of guides for controlling opposing articulation directions, wherein the actuator reduces stress induced on at least one of a pushed guide or a non-activated guide, wherein the stress is induced in response to the actuator pulling a guide.
2. The probe of claim 1, the actuator, comprising:
 - a disc configured to rotate about a rotation axis, the disc including:
 - a first portion providing a first travel distance; and a second opposing portion providing a second travel distance, wherein the first travel distance is less than the second travel distance, the first and second half portions correspond to first and second halves of the disc, and the second opposing half portion faces the at least two vertebrae elements.
 3. The probe of claim 2, wherein a first guide of a pair of guides is affixed at the disc at a location corresponding to a first end of the first half portion at a transition from the first to the second portion, and a second guide of the pair of guides is affixed at the disc at a location corresponding to a second opposing end of the first half portion at a transition from the first to the second portion.
 4. The probe of claim 3, the actuator, comprising:
 - a lever affixed to the disc, wherein the lever rotates the disc in coordination with rotation of the lever.
 5. The probe of claim 4, wherein the second opposing half portion guides one of the first or second guides during articulation.
 6. The probe of claim 5, wherein the second opposing half portion guides a pulled guide of the first or second guides during articulation, which results in reduced stress on a pushed guide of the first or second guides.
 7. The probe of claim 1, the actuator, comprising:
 - a first control corresponding to first opposing articulation directions, the first control including: a first cam, a first lever and a first guide system, which controls a slack of a pair of guides for the first opposing articulation directions; and
 - a second control corresponding to second opposing articulation directions, the second control including: a second cam, a second lever, and a member configured to control the first guide system of the first control.

8. The probe of claim 7, wherein the first guide system includes a set of wheels, each attached to a pivoting member, which is pivotably attached to a translating member, which is moveably attached to a slide member.

9. The probe of claim 8, wherein the second cam is circular in shape and includes a sub-cam, and the sub-cam supports the member when the second lever is not actuated, and the member holds the first guide system at a first position along the slide member.

10. The probe of claim 9, wherein a perimeter of the second cam, excluding the sub-cam, supports the member when the second lever is actuated, and the member holds the first guide system at a second position along the slide member.

11. The probe of claim 10, wherein the set of wheels pivot towards each other at the second position, slacking off the pair of guides.

12. The probe of claim 11, wherein the slacking off the pair of guides reduces stress induced on the non-activated guides.

13. The probe of claim 1, wherein one pair of the guides controls up/down articulation directions and another pair of the guides controls left/right articulation directions.

14. The probe of claim 1, wherein the probe includes a laparoscopic probe.

15. An elongate ultrasound imaging probe, comprising:
a flexor configured to flex a tip of the probe, where the tip of the probe houses a transducer array;
a flexor control system configured to control the flexor to flex the tip in one of a plurality of different directions through pulling and pushing on guides affixed to the flexor; and

a flexor actuator configured to actuate the flexor control system to selectively pull and push on the guides.

16. The elongate ultrasound imaging probe of claim 15, where a push length of one guide is greater than a pull length

of a corresponding guide, and the flexor actuator includes a disc shaped cam having two halves that provide different travel distances that compensates for a difference in the push and pull lengths.

17. The elongate ultrasound imaging probe of claim 16, wherein the compensation reduces stress induced by the pushed guide resulting from the difference in the push and pull lengths.

18. The elongate ultrasound imaging probe of claim 15, where the flexor actuator reduces stress induced in a pair of non-actuated guides resulting from actuation of a different pair of guides.

19. The probe of claim 1, wherein the probe includes a biopsy feature.

20. An ultrasound imaging system, comprising:
a probe, including:

a probe head with a transducer array;
a shaft;

an articulating member disposed between the probe head and the shaft;

an articulating member actuator configured to control the articulating member through guide wires, wherein the articulating member reduces stress in the guide wires through a structural elements that slack off at least one of a pushed guide wire or a non-activated guide wire in response to at least one pulled guide wire; and

a console interface;

a console, including: ultrasound imaging components; and a probe interface,

wherein the console and probe interfaces are complementary interfaces, providing an electrical communications path between the probe and the console.

* * * * *

专利名称(译)	超声成像探头的关节激活线应力消除		
公开(公告)号	US20180000315A1	公开(公告)日	2018-01-04
申请号	US15/543651	申请日	2015-01-16
[标]申请(专利权)人(译)	B-K医疗公司		
申请(专利权)人(译)	B-k医疗APS		
当前申请(专利权)人(译)	B-k医疗APS		
[标]发明人	CHRISTENSEN BJARNE LASSE SASADY NIELS CHRISTIAN LL		
发明人	CHRISTENSEN, BJARNE LASSE SASADY, NIELS-CHRISTIAN LL		
IPC分类号	A61B1/008 A61B1/00 A61B1/005 A61B8/00		
CPC分类号	A61B1/008 A61B1/0057 A61B1/00006 A61B8/445 A61B1/0052 A61B1/00016 A61B1/00133 A61B1/015 A61B1/267 A61B8/12		
外部链接	Espacenet USPTO		

摘要(译)

探针包括铰接构件，该铰接构件具有沿细长超声成像探头的长轴顺序布置的至少两个椎骨元件。铰接构件包括位于至少两个椎骨元件之间的枢轴。枢轴相对于至少两个椎骨元件偏心设置。枢轴在空间上定向，以为椎骨元件的不同关节运动方向提供枢轴点。探针还包括多个引导件，包括用于各个不同枢转方向中的每一个的至少一个引导件。探针还包括具有一组控制器的致动器，每个控制器配置成致动不同对的多个引导件以控制相对的铰接方向，其中致动器减小在推动引导件或未激活引导件中的至少一个上引起的应力。导向装置，其中响应于致动器拉动导向装置而引起应力。

