



US 20170290561A1

(19) **United States**

(12) **Patent Application Publication**
McPeak

(10) **Pub. No.: US 2017/0290561 A1**
(43) **Pub. Date: Oct. 12, 2017**

(54) **MEDICAL DEVICE IMAGABLE BY
ULTRASOUND**

(71) Applicant: **Covidien LP**, Mansfield, MA (US)

(72) Inventor: **Thomas McPeak**, Shakopee, MN (US)

(21) Appl. No.: **15/092,023**

(22) Filed: **Apr. 6, 2016**

Publication Classification

(51) **Int. Cl.**
A61B 8/08 (2006.01)
A61M 25/10 (2006.01)
A61B 90/00 (2006.01)

(52) **U.S. Cl.**
CPC *A61B 8/0841* (2013.01); *A61B 8/481*
(2013.01); *A61B 90/39* (2016.02); *A61M*
25/10 (2013.01); *A61B 2090/3925* (2016.02);
A61M 2025/1093 (2013.01); *A61M 25/0108*
(2013.01)

(57) **ABSTRACT**

A medical device includes a structural element comprising an outer surface and a material on the outer surface of the structural element. The material defines void spaces containing a gas entrained within the void spaces. The material, upon contact with physiological fluid, is configured to release the gas in an amount sufficient for the gas to be imaged by ultrasound.

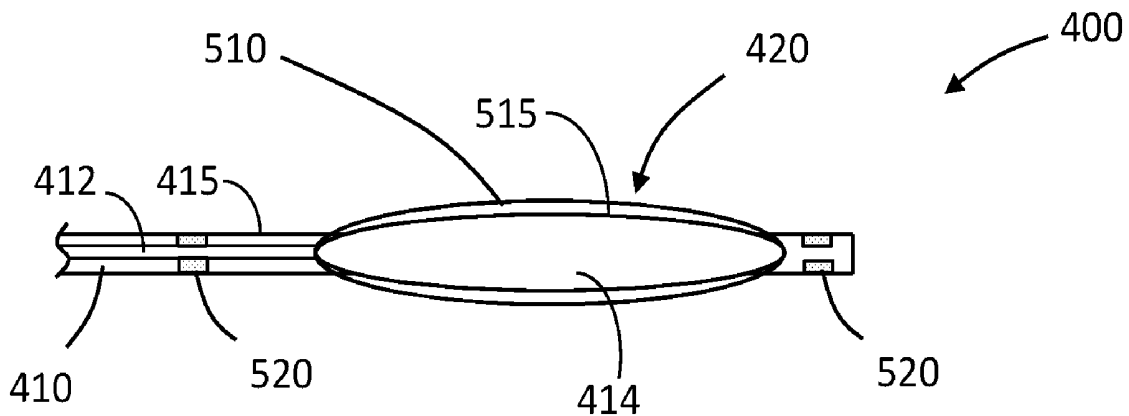

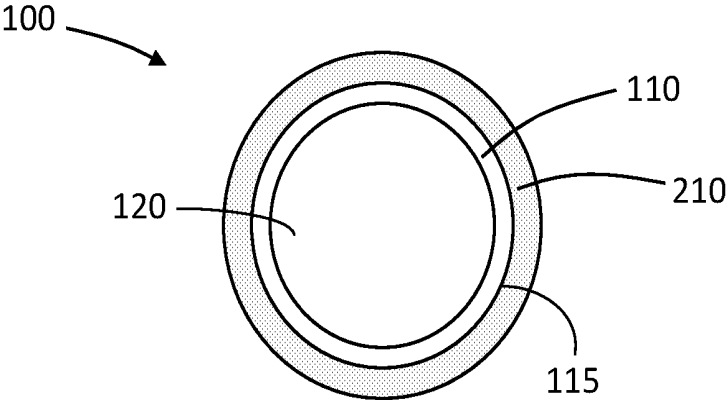

FIG. 1

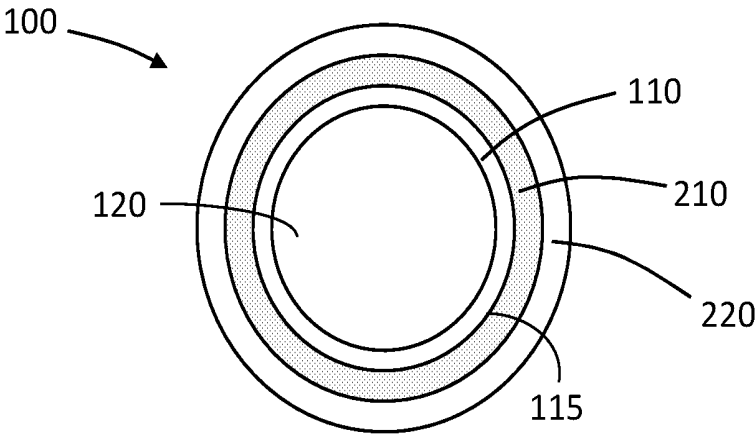

FIG. 2

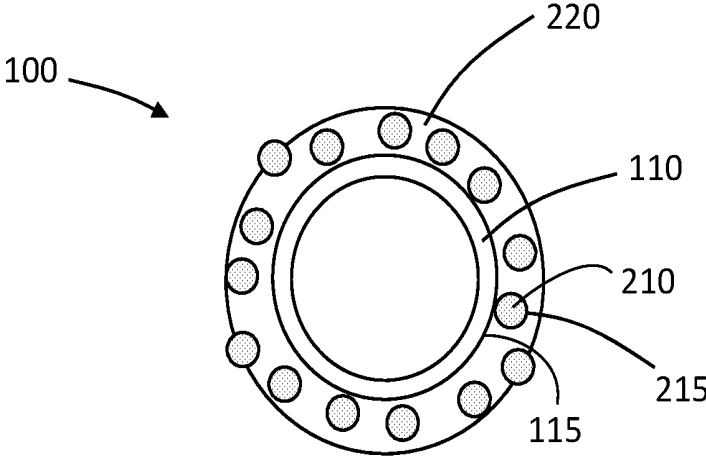

FIG. 3

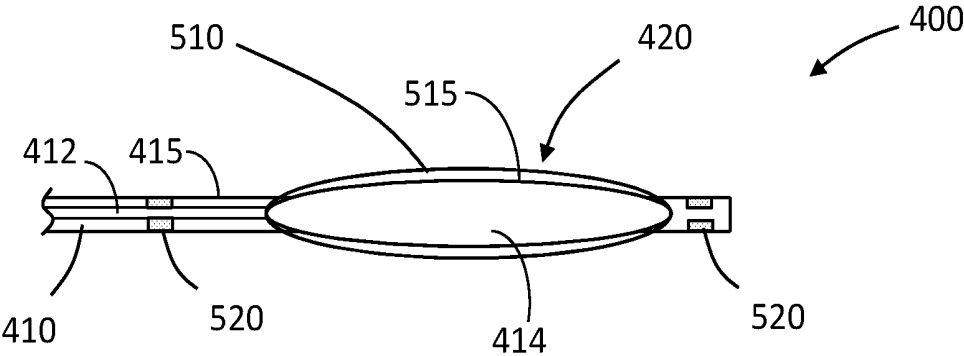

FIG. 4

MEDICAL DEVICE IMAGABLE BY ULTRASOUND

FIELD

[0001] The present disclosure relates to, among other things, medical devices, or portions thereof, visible via ultrasound.

TECHNICAL BACKGROUND

[0002] Many medical procedures, whether interventional or diagnostic, include use of instruments that are, or have markers that are, visible by fluoroscopy. Fluoroscopy requires the use of radiation for visualization, which may present health concerns for both patients and clinicians.

[0003] Ultrasound techniques, which do not employ radiation, provide an alternative to fluoroscopy. However, many medical devices do not provide for sufficient contrast for accurate imaging via ultrasound.

BRIEF SUMMARY

[0004] Described herein, among other things, are medical devices that are configured to provide good contrast for viewing by ultrasound. The devices include material that contains or releases gas to enhance ultrasound echogenicity. In some embodiments, the devices, or one or more portions thereof, are coated with a material that releases gas, such as carbon dioxide, when introduced into a patient. In many embodiments, the devices are configured for placement or movement through a patient's vasculature. As the device is moved through the patient, the location of the device or one or more portion thereof may be effectively monitored by ultrasound.

[0005] In general, in one aspect, the present disclosure describes a medical device includes a structural element comprising an outer surface and a material on the outer surface of the structural element. The material defines void spaces containing a gas entrained within the void spaces. The material, upon contact with physiological fluid, is configured to release the gas. Preferably, the material is configured to release the gas in an amount sufficient for the gas to be imaged by ultrasound. Preferably, the material is configured to release the gas in an amount sufficient for the gas to be imaged by extracorporeal ultrasound.

[0006] In various embodiments, the device further comprises a coating on the outer surface of the device, wherein the coating comprises the material. In certain embodiments, the coating comprises a hydrogel.

[0007] In embodiments, the material dissolves in physiological fluid. In various embodiments, the material has a solubility of 100 mg/ml or more in pH 7.4 phosphate buffered saline at room temperature.

[0008] In various embodiments, the material defining the void space in which the gas is entrained comprises a monosaccharide or polysaccharide. In certain embodiments, the monosaccharide or polysaccharide comprises sucrose or glucose.

[0009] In embodiments, the device further comprises an outer coating disposed over the material defining the void space in which the gas is entrained. In certain embodiments, the outer coating is a hydrophilic lubricous coating.

[0010] In embodiments, the material defining the void space in which the gas is entrained comprises a plurality of microspheres, each defining an interior volume, and the gas

is present within that interior volume. In various embodiments, a liquid is in the interior volume of the microspheres and the gas is entrained in the liquid. In various embodiments, the gas comprises carbon dioxide.

[0011] In embodiments, the structural element comprises an inflatable balloon. In other embodiments, the structural element comprises a catheter. In various embodiments, the structure comprises an inflatable balloon and a catheter.

[0012] In general, in another aspect, the present disclosure describes a method comprising providing a medical device of any of the embodiments described above, or combinations thereof. The structural element of the medical device is inserted into a patient's vasculature, and the location of the structural element within the vasculature is identified via extravascular ultrasound.

[0013] In embodiments, the structural element is an inflatable balloon, and the method further comprises inflating the inflatable balloon within the vasculature. The method may further comprise imaging inflation of the inflatable balloon via extravascular ultrasound.

[0014] In general, in yet another aspect, the present disclosure describes a method of making a medical device. A gas is entrained into a material, wherein the material defines void spaces and the gas is entrained within the void spaces. The material is disposed on an outer surface of a structural element of the medical device. The material is configured to release the gas from the voids in the material upon contact with a physiological fluid in an amount sufficient for the released gas to be imaged by extracorporeal ultrasound.

[0015] In embodiments, the structural element is an inflatable balloon. In various embodiments, the gas is carbon dioxide. In various embodiments, the material may be at least one of a water-soluble polymer, a monosaccharide, a polysaccharide, and microspheres.

[0016] The disclosure can be implemented to realize one or more of the following advantages. The medical device can be visualized using ultrasound, thereby eliminating the need for fluoroscopy, and thus not subjecting the patient to radiation. Further, the release of gas may also help the physician also image the vessel in which the medical device is being used. Further still, more of the medical device and structure may be imaged as compared to the use of narrow, discrete marker bands. Additional advantages and features of the subject matter of the present disclosure will be set forth in the detailed description which follows, and in part will be readily apparent to those skilled in the art from that description or recognized by practicing the subject matter of the present disclosure as described herein, including the detailed description which follows, the claims, as well as the appended drawings.

[0017] It is to be understood that both the foregoing general description and the following detailed description present embodiments of the subject matter of the present disclosure, and are intended to provide an overview or framework for understanding the nature and character of the subject matter of the present disclosure as it is claimed. The accompanying drawings are included to provide a further understanding of the subject matter of the present disclosure, and are incorporated into and constitute a part of this specification. The drawings illustrate various embodiments of the subject matter of the present disclosure and together with the description serve to explain the principles and operations of the subject matter of the present disclosure.

Additionally, the drawings and descriptions are meant to be merely illustrative, and are not intended to limit the scope of the claims in any manner.

BRIEF DESCRIPTION OF THE DRAWINGS

[0018] The following detailed description of specific embodiments of the present disclosure can be best understood when read in conjunction with the following drawings, in which:

[0019] FIG. 1 is a schematic sectional view of an embodiment of a medical device having a gas-containing material on an exterior surface of a structural element;

[0020] FIG. 2 is a schematic sectional view of an embodiment of a medical device having a gas-containing material on an exterior surface of a structural element and a coating on the gas-containing material;

[0021] FIG. 3 is a schematic sectional view of an embodiment of a medical device having a coating on an exterior surface of a structural element where the coating includes a gas-containing material; and

[0022] FIG. 4 is a schematic sectional view of a balloon catheter in accordance with various embodiments described herein.

[0023] The schematic drawings are not necessarily to scale.

DETAILED DESCRIPTION

[0024] Reference will now be made in greater detail to various embodiments of the subject matter of the present disclosure, some embodiments of which are illustrated in the accompanying drawings. Like numbers used in the figures refer to like components, steps and the like. However, it will be understood that the use of a number to refer to a component in a given figure is not intended to limit the component in another figure labeled with the same number. In addition, the use of different numbers to refer to components in different figures is not intended to indicate that the different numbered components cannot be the same or similar to other numbered components.

[0025] The present disclosure describes, among other things, a medical device including a structural element comprising an outer surface and a material on the outer surface of the structural element. The material defines void spaces and contains a gas entrained within the void spaces. The material, upon contact with physiological fluid, is configured to release the gas in an amount sufficient for the gas to be imaged by ultrasound.

[0026] Any suitable medical device may include a gas-containing material as described herein. Any device having at least a portion that is inserted into a patient may advantageously include a gas-containing material as described herein. In some embodiments, the device is configured to be placed in or moved through a vasculature of a patient. For example, the device may be an angioplasty device, a stent delivery device, or a diagnostic device. In some embodiments, the device is an implantable medical device; e.g., a device configured to remain in a patient for more than a week, such as a stent.

[0027] The material may be located at any suitable portion of the device or over the entire device. Preferably the material is positioned at an external surface of the device that is configured to contact physiological fluid of a patient. In some embodiments, the material is at locations in which

radiopaque material or marker bands are employed for currently available devices. For example, if the material is present on a stent delivery catheter, the material may form one or more bands distal to, proximal to, or at a location where the stent is configured to be retained. However, an advantage of using this material as a coating is the ability to visualize more of the device than just defined bands.

[0028] In some embodiments, the device comprises a balloon catheter and the balloon comprises a coating having the gas-releasing material, or a sheet of the gas releasing material is disposed about the balloon. Accordingly, the balloon may be effectively visualized by ultrasound as the balloon is moved through the vasculature. In some embodiments, such as when the balloon is coated with the gas-releasing material, inflation of the balloon in the vasculature may be visualized by ultrasound, which can provide feedback to a clinician of effectiveness of treatment.

[0029] Any suitable material may be used to entrain gas to be released. The material defines void spaces in which the gas is entrained. The material is configured to release the gas when in contact with physiological fluid, such as blood or interstitial fluid. The material may dissolve, degrade, invert, chemically react, or otherwise change state or orientation to release the entrained gas when placed in contact with physiological fluid. The release of the gas preferably occurs over time, particularly over the time that a particular procedure employing a device including such a material may take.

[0030] Examples of suitable materials in which the gas may be entrained include sugars, water soluble biocompatible polymers, and microspheres. Suitable sugars may be monosaccharides or polysaccharides, such as disaccharides. Suitable sugars include glucose, fructose, sucrose, xylose and the like. The sugars may be heated until they melt into a syrup. The syrup may be exposed to pressurized gas and allowed to cool and solidify causing high-pressure gas to be trapped inside the resultant solid. The syrup can be exposed to any suitable pressure of gas. For example, the pressure may be 0.5 bar or greater, 1 bar or greater, 5 bar or greater, 10 bar or greater, or 20 bar or greater. Typically the pressure of the gas will be less than 100 bar. In some embodiments, the pressure of the gas will be from about 20 bar to about 60 bar, such as from about 30 bar to about 50 bar, or about 40 bar. The resulting solid may be molded into a desired shape to be placed about a medical device, broken into pieces of suitable size for incorporating into a coating to be placed on a medical device, or the like, or a medical device or portion thereof may be molded around at least a portion of the resulting solid. For example, a ring of the resulting solid may be placed in a mold in which a catheter is formed so that the ring can form an ultrasonic marker band of gas-containing material.

[0031] Any suitable water soluble biocompatible polymer may be used to entrain gas. Preferably, the material includes a thermoplastic water soluble polymer. Examples of thermoplastic water soluble polymers include polyethylene oxide (such as POLYOX water-soluble poly(ethylene) oxide polymers available from the Dow Chemical Company), polyvinyl alcohol, and cellulose ethers, such as hydroxypropyl methylcellulose and hydroxyethyl methylcellulose. One or more water soluble thermoplastic polymers may be used to form a material in which gas may be entrained. In some embodiments, the one or more water soluble thermoplastic polymers are heated until they melt, exposed to

pressurized gas, and cooled to form a solid in which high-pressure gas may be trapped. The melt can be exposed to any suitable pressure of gas. For example, the pressure may be 0.5 bar or greater, 1 bar or greater, 5 bar or greater, 10 bar or greater, or 20 bar or greater. Typically the pressure of the gas will be less than 100 bar. In some embodiments, the pressure of the gas will be from about 20 bar to about 60 bar, such as from about 30 bar to about 50 bar, or about 40 bar. The resulting solid may be molded into a desired shape to be placed about a medical device, a medical device or portion thereof may be molded around at least a portion of the resulting solid, or the like. For example, a ring of the resulting solid may be placed in a mold in which a catheter is formed so that the ring can form an ultrasonic marker band of gas-containing material.

[0032] In some embodiments, the material in which the gas is entrained has a solubility in physiological saline at pH 7.4 and 37° C. of 50 mg/ml or more, such as 100 mg/ml or more. In some embodiments, the material will have a solubility in physiological saline at pH 7.4 and 37° C. of less than 5000 mg/ml.

[0033] Further, any suitable microspheres may be used to entrain gas. For example, the microsphere may include an amphiphilic polymer, such as a block copolymer having one or more hydrophobic blocks and one or more hydrophilic blocks. Upon contact with physiological fluid, the microspheres may release the gas contained within the microsphere. The gas may be, for example, in a super-saturated solution within the microsphere.

[0034] Examples of select microspheres known in the art that may be used to contain a gas include, but are not limited to, poly(D,L-lactide-co-glycolide) (PLGA) microspheres; poly(epsilon-caprolactone) (PCL) microspheres; poly(D,L-lactide)/poly(D,L-lactide-co-glycolide) composite microparticles; alginate-poly-L-lysine alginate (APA) microcapsules; alginate microspheres; poly(D,L-lactic-co-glycolic acid) microspheres; chitosan microspheres; poly[p-(carboxyethylformamido)-benzoic anhydride] (PCEFB) microspheres; Hyaluronan-based microspheres; biodegradable microspheres; microspheres of PMMA-PCL-cholesterol; poly(propylene fumarate)/poly(lactic-co-glycolic acid) blend microspheres; poly(lactide-co-glycolide acid-glucose) microspheres; polylactide co-glycolide (PLG) microspheres; poly(methacrylic acid) microspheres; poly(methylidene malonate 2.1.2)-based microspheres; ammonio methacrylate copolymer microspheres; poly(ethylene oxide)-modified poly(beta-amino ester) microspheres; methoxy poly(ethylene glycol)/poly(epsilon-caprolactone) microspheres; polyferrocenylsilane microspheres; poly(fumaric-co-sebacic acid) (P(FASA)) microspheres; poly(lactide-co-glycolide) and poly(ethylene oxide)-poly(propylene oxide)-poly(ethylene oxide) triblock copolymer microspheres; polyisobutylcyanoacrylate microspheres; polystyrene core-glycopolymer corona nanospheres; poly(ethyl-2-cyanoacrylate) microspheres; POE-PEG-POE triblock copolymeric microspheres; poly(DL-lactide) microparticles; albumin microspheres; poly(EGDMA/HEMA) based microbeads; glutaraldehyde crosslinked sodium alginate microbeads; pectin microspheres; methoxy poly(ethylene glycol) and glycolide copolymer microspheres; crosslinked polyethyleneimine microspheres; poly(glycidyl methacrylate-co-ethylene dimethacrylate); cellulose acetate trimellitate ethylcellulose blend microspheres; poly(ester) microspheres;

polyacrylamide microcarriers; polyacrolein microspheres; 2-hydroxyethyl methacrylate microspheres

[0035] The microspheres may be of varying size. Suitable size microspheres include those ranging from between about 10 and about 5000 nm in outside diameter, preferably between about 50 and about 500 nm in outside diameter. Most preferably, the microspheres are about 75 nm to about 200 nm in outside diameter.

[0036] The microspheres may be prepared by various processes, as will be readily apparent to those skilled in the art, such as by interfacial polymerization, phase separation and coacervation, multiorifice centrifugal preparation, and solvent evaporation, or a combination thereof. The microspheres may be formed under pressurized gas so that the gas may be captured in or entrained within liquid in the microsphere. Any suitable pressure may be employed. For example, the pressure may be 0.5 bar or greater, 1 bar or greater, 5 bar or greater, 10 bar or greater, or 20 bar or greater. Typically the pressure of the gas will be less than 100 bar. In some embodiments, the pressure of the gas will be from about 20 bar to about 60 bar, such as from about 30 bar to about 50 bar, or about 40 bar.

[0037] Microspheres or other suitable gas-containing material may be included in a coating applied to a medical device, may be applied to the device and over-coated with an outer coating, or the like. The coating or outer coating may assist in retaining the gas-containing material in place on the device, may serve to facilitate movement of the device through the patient, or the like. Preferably, the coating or outer coating allows the material to come in contact with body fluid. Alternatively or in addition, the coating or outer coating may react with body fluid to cause the material to release the gas.

[0038] In some embodiments, the coating or outer coating is a lubricious hydrophilic coating. Any suitable lubricious coating may be employed. Preferably, the hydrophilic nature of lubricious coatings allows physiological fluid to reach the gas-containing material to cause release of the gas from the material when the device is inserted in a patient. The references to coatings in general below refer to both the coating in which the gas may be entrained and potential outer coatings.

[0039] Examples of suitable lubricious coatings include coatings comprising one or more of polyvinylpyrrolidone, polyethylene oxide, hyaluronic acid and its salts, polyacrylic acid and its derivatives, polyurethane, acrylic polyester, and the like.

[0040] In some embodiments, the coating comprises a polysaccharide. The polysaccharide may be cross-linked. For example, the polysaccharide may be chemically cross-linked glutaraldehyde or another compound having at least two aldehyde groups. By way of another example, cross-linking may be ionic. Ionic cross-linking may be particularly suitable for polysaccharides having acid functional groups, such as glycosaminoglycans. Examples of suitable glycosaminoglycans having acid functional groups include hyaluronic acid, xanthan gum, carrageenan, tragacanth, gellan gum and pectins. Crosslinking may be provided with a biocompatible polyvalent cation such as calcium, magnesium or iron. In some cases a polymer with multiple cationic groups may be utilized.

[0041] In some embodiments, the coating comprises hyaluronic acid or a salt thereof. Hyaluronic Acid (HA) is a water soluble high molecular weight (MW) polysaccharide

commonly found in normal human tissue, as well as a number of other natural sources. It is biocompatible, non-thrombogenic, highly hydrophilic, hygroscopic, and with a high intrinsic viscosity at high MW and concentration. HA is highly insoluble in most organic solvents and will remain stable during most drug coating processes that include organic solvents. HA can be of various MW, although MWs of greater than or equal to 1×10^6 Da are preferred due to a higher degree of chain interaction. In some embodiments the coating consists of or consists essentially of HA. In some embodiments, the coating may include HA mixed with varying amounts of another polymer, such as PVA or collagen, to adjust visco-elastic properties. In some embodiments, the HA is cross-linked to increase stability of the resulting HA layer or alter the rate of degradation.

[0042] The material or the material and the coating, if present, may be adjusted to tailor the release profile of the gas from the material following insertion of the device in the patient. Preferably, the material releases gas over the course of a procedure in which the medical device is employed or during a procedure in which the medical device is implanted. Preferably, gas is released from the material on the medical device within 5 minutes of contact with physiological fluid; more preferably within 1 minute, and even more preferably within seconds of contact with physiological fluid. Preferably, gas is released from the material on the medical device until the device is removed from the patient or implanted in the patient. For example and in some embodiments, gas may be released for up to 1 hour when material on the device is in contact with physiological fluid. In some embodiments, release for up to 30 minutes, up to 15 minutes, up to 10 minutes, up to 5 minutes, or even up to one minute will be sufficient.

[0043] It will be understood that the gas release profile and the location of the gas-containing material on the device will vary depending of the medical device and the procedure for which the device is employed.

[0044] The gas-containing material may entrain any suitable gas within a void space defined by the material. For example, the gas may comprise one or more of oxygen, carbon dioxide, and nitrogen. Carbon dioxide should not have therapeutic or side effects, while oxygen and nitrogen may have desired therapeutic effects or unintended side effects. It will be understood that the choice of gas employed will depend, in part, on the medical device, the procedure for which the device is employed, the location of the gas-containing material on the device, and the like.

[0045] Preferably, the gas is present in the material at a pressure above atmospheric pressure. More preferably, the gas is present in the material at a pressure above a relevant physiological pressure, such as blood pressure which is about 0.2 bar. Preferably, the gas is present in the material at a pressure below a pressure that may result in a release rate that is too high for patient safety. The maximum pressure for a gas in a material may depend on, not only the pressure, but also the material in which the gas is entrained, the area of the body in which a device containing the material is used, and the like. In some embodiments, the gas entrained in a void space of the material may be at a pressure of from about 0.2 bar to about 50 bar such as from about 1 to about 40, or about 2 bar to about 20 bar. For purposes of the present disclosure, pressures referred to herein are gauge pressures.

[0046] Preferably, gas bubbles are formed in a physiological fluid when the gas is released from the material in the fluid. Preferably, a sufficient amount of gas bubbles are formed to enhance ultrasound echogenicity. Preferably, the gas is released from the material as gas bubbles having an outer diameter in a range from about 1 micrometer to about 1000 micrometers. Bubbles of such sizes should be sufficient to enable effective visualization by ultrasound, such as extracorporeal ultrasound.

[0047] Referring now to FIG. 1, a sectional view of a medical device 100 is shown. The device 100 includes a structural element 110 having an external surface 115, and a gas-containing material 210 on the external surface 115 of the structural element 110. In the depicted embodiment, the structural element 110 forms a lumen 120. For example, the structural element may comprise a catheter or an inflatable balloon.

[0048] Referring now to FIG. 2, a sectional view of a medical device 100 is shown. The device 100 includes a structural element 110, a gas-containing material 210 on an external surface 115 of the structural element 110, and an outer coating 220 on the material 210. The material 210 may be coated or otherwise disposed on the structural element 110.

[0049] Referring now to FIG. 3, a sectional view of a medical device 100 is shown. The device 100 includes a structural element 110 and coating 220 on an external surface 115 of the structural element. The coating 220 comprises gas-containing material 210 disposed in, for example, microspheres 215.

[0050] It will be understood that FIGS. 1-3 depict only some ways in which a gas-containing material may be disposed on a structural element of a medical device and that other orientations are envisioned. For example, while microspheres 215 are depicted in FIG. 3, in other embodiments the gas containing material 210 may be entrained within the coating 220 itself, such as by mixing the gas containing material 210 within the coating 220 while the coating is in a liquid state.

[0051] In embodiments where the structural element is an inflatable balloon, the balloon may be coated while inflated or deflated and folded. The gas-containing material or the coating material may be placed on an external surface of the balloon by, for example, dipping, spraying, or otherwise depositing a solution containing the material or coating on the balloon and evaporating a solvent, leaving the material or coating deposited on the balloon. If the balloon is folded, the material or coating may penetrate under the folds by capillarity action or may be applied, by for example, micro-nozzles under the folds. One or more layers of a solution comprising the material or coating may be applied to the balloon. Alternatively, a sheet comprising the material or coating may be placed around the balloon.

[0052] Referring now to FIG. 4, a sectional view of a balloon catheter 400 is shown. The balloon catheter 400 includes a catheter 410 and a balloon 420, which are structural elements of the medical device. The catheter 410 defines a lumen 412 in communication with the interior 414 of the balloon 420 for inflating the balloon 420. The balloon catheter 400 further includes optional rings 520 of gas-containing material embedded in the catheter 410 and exposed on an external surface 415 for contact with physiological fluid when inserted in a patient. Gas-containing material 510 is also disposed on an exterior surface 515 of

the balloon 420. When inserted into a patient, gas bubbles may be released from the material 510 disposed on the balloon 420 and the rings 520 upon contact of the material with physiological fluid. The gas bubbles may enhance ultrasound echogenicity enabling effective ultrasound imaging of the balloon 420 and rings 520 as the balloon catheter 400 is advanced through the patient. Inflation of the balloon 420 may also effectively be imaged by ultrasound via gas released from material 510 on balloon 420. Further, as the released gas disperses into the vessel, the vessel may become more easily imaged under the ultrasound, further enhancing the ability of the physician to visualize the procedure.

[0053] All scientific and technical terms used herein have meanings commonly used in the art unless otherwise specified. The definitions provided herein are to facilitate understanding of certain terms used frequently herein and are not meant to limit the scope of the present disclosure.

[0054] The words “preferred” and “preferably” refer to embodiments of the disclosure that may afford certain benefits, under certain circumstances. However, other embodiments may also be preferred, under the same or other circumstances. Furthermore, the recitation of one or more preferred embodiments does not imply that other embodiments are not useful, and is not intended to exclude other embodiments from the scope of the inventive technology.

[0055] It will be apparent to those skilled in the art that various modifications and variations can be made to the present inventive technology without departing from the spirit and scope of the disclosure. Since modifications, combinations, sub-combinations and variations of the disclosed embodiments incorporating the spirit and substance of the inventive technology may occur to persons skilled in the art, the inventive technology should be construed to include everything within the scope of the appended claims and their equivalents.

- 1: A medical device, comprising:
 - a structural element comprising an outer surface; and
 - a material on the outer surface of the structural element, the material defining void spaces containing a gas entrained within the void spaces,
 - wherein, upon contact with physiological fluid, the material is configured to release the gas in an amount sufficient for the released gas to be imaged by extracorporeal ultrasound.
- 2: The medical device of claim 1, further comprising a coating on the outer surface of the device, wherein the coating comprises the material.
- 3: The medical device of claim 2, where the coating comprises a hydrogel.
- 4: The medical device of claim 1, where the material dissolves in physiological fluid.
- 5: The medical device of claim 1, wherein the material has a solubility of 100 mg/ml or more in pH 7.4 phosphate buffered saline at room temperature.
- 6: The medical device of claim 1, wherein the material defining the void space in which the gas is entrained comprises a monosaccharide or polysaccharide.
- 7: The medical device of claim 6, wherein the monosaccharide or polysaccharide comprises sucrose or glucose.

8: The medical device of claim 1, further comprising an outer coating disposed over the material defining the void space in which the gas is entrained.

9: The medical device of claim 8, wherein the coating is a hydrophilic lubricous coating.

10: The medical device of claim 1, wherein the material defining the void space in which the gas is entrained comprises a plurality of microspheres, each defining an interior volume, and wherein the gas is present in the interior volume.

11: The medical device of claim 10, wherein a liquid is in the interior volume of the microspheres and wherein the gas is entrained in the liquid.

12: The medical device of claim 1, wherein the gas comprises carbon dioxide.

13: The medical device of claim 1, wherein the structural element comprises an inflatable balloon.

14: The medical device of claim 1, wherein the structural element comprises a catheter.

15: A method comprising

providing a medical device comprising

- a structural element comprising an outer surface; and
- a material on the outer surface of the structural element, the material defining void spaces containing a gas entrained within the void spaces,

- wherein, upon contact with physiological fluid, the material is configured to release the gas in an amount sufficient for the released gas to be imaged by extracorporeal ultrasound;

- inserting the structural element of the medical device into a patient's vasculature; and

- identifying the location of the structural element within the vasculature via extravascular ultrasound.

16: The method of claim 15, wherein the structural element is an inflatable balloon, and wherein the method further comprises inflating the inflatable balloon within the vasculature.

17: The method of claim 16, further comprising imaging inflation of the inflatable balloon via extravascular ultrasound.

18: A method of making a medical device, comprising:

- entraining a gas into a material, wherein the material defines void spaces and the gas is entrained within the void spaces; and

- disposing the material on an outer surface of a structural element of the medical device;

- wherein the material is configured to release the gas from the voids in the material upon contact with a physiological fluid in an amount sufficient for the released gas to be imaged by extracorporeal ultrasound.

19: The method of claim 18, wherein the structural element is an inflatable balloon.

20: The method of claim 18, wherein the gas is carbon dioxide.

21: The method of claim 18, wherein the material is selected from the group consisting of a water-soluble polymer, a monosaccharide, a polysaccharide, and microspheres.

* * * * *

专利名称(译)	超声波可以想象的医疗设备		
公开(公告)号	US20170290561A1	公开(公告)日	2017-10-12
申请号	US15/092023	申请日	2016-04-06
[标]申请(专利权)人(译)	柯惠有限合伙公司		
申请(专利权)人(译)	COVIDIEN LP		
当前申请(专利权)人(译)	COVIDIEN LP		
[标]发明人	MCPEAK THOMAS		
发明人	MCPEAK, THOMAS		
IPC分类号	A61B8/08 A61M25/10 A61B90/00		
CPC分类号	A61B8/0841 A61B8/481 A61B90/39 A61M2202/0225 A61B2090/3925 A61M2025/1093 A61M25/0108 A61M25/10 A61B8/12 A61K49/223 A61L29/085 A61L29/18 A61L2300/622 A61L2400/10 A61M2025/1075 A61M2025/1088 A61L29/145 A61L29/146 A61L29/148 A61M2025/1031		
外部链接	Espacenet USPTO		

摘要(译)

医疗装置包括结构元件，该结构元件包括外表面和在结构元件的外表面上的材料。该材料限定了包含在空隙空间内夹带的气体的空隙空间。该材料在与生理流体接触时被配置成以足以使气体通过超声成像的量释放气体。

