



US 20150016744A1

(19) **United States**
(12) **Patent Application Publication**
Tsao et al.

(10) **Pub. No.: US 2015/0016744 A1**
(43) **Pub. Date: Jan. 15, 2015**

(54) **DIAGNOSTIC ULTRASOUND APPARATUS**

Publication Classification

(71) Applicant: **HITACHI ALOKA MEDICAL, LTD.**,
Mitaka-shi (JP)

(51) **Int. Cl.**
G06T 5/00 (2006.01)
A61B 8/08 (2006.01)

(72) Inventors: **Jing-Wen Tsao**, Mitaka-shi (JP); **Shingo Yoshizawa**, Mitaka-shi (JP)

(52) **U.S. Cl.**
CPC *G06T 5/003* (2013.01); *A61B 8/5207*
(2013.01); *A61B 8/5223* (2013.01); *G06T*
2207/10132 (2013.01); *G06T 2207/10016*
(2013.01); *G06T 2207/20024* (2013.01)
USPC **382/263**

(73) Assignee: **HITACHI ALOKA MEDICAL, LTD.**,
Mitaka-shi (JP)

(57) **ABSTRACT**

(21) Appl. No.: **14/380,290**

In ultrasound images, there are many stationary echoes in the region superficial to the deep region comprising the heart. In the present invention, a HPF processing unit (20) filters frame data by applying a high pass filter, the characteristics of which have been set according to the depth in the frame, on the frame data at said depth. The high pass filter can be achieved, for example, with a digital filter and the characteristics of the high pass filter are adjusted by the filter-setting unit (22) setting the filter coefficient of said digital filter. That is to say, the filter coefficient in the HPF processing unit (20) is controlled by the filter-setting unit (22) so that the deeper the region, the higher the offset level is set.

(22) PCT Filed: **Feb. 19, 2013**

(86) PCT No.: **PCT/JP2013/054015**

§ 371 (c)(1),

(2) Date: **Aug. 21, 2014**

(30) **Foreign Application Priority Data**

Mar. 1, 2012 (JP) 2012-045280

Mar. 1, 2012 (JP) 2012-045282

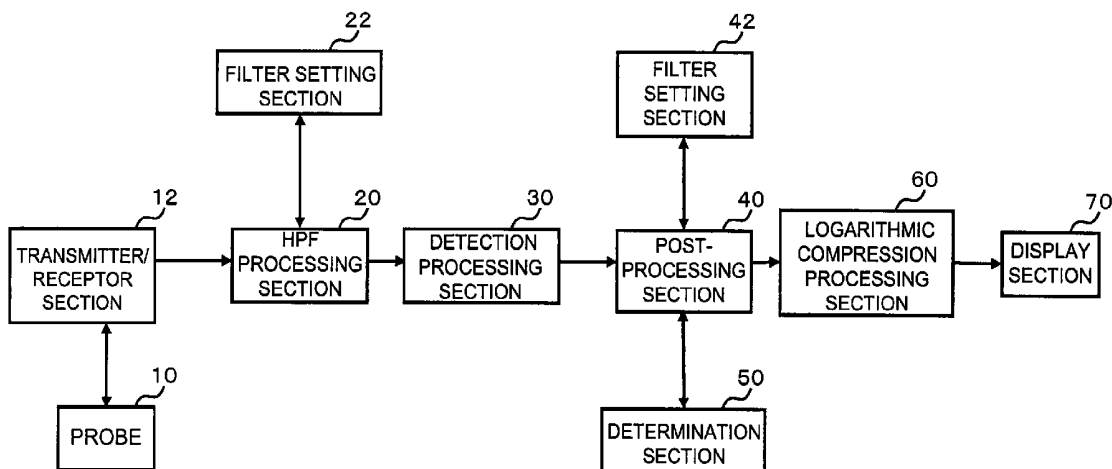

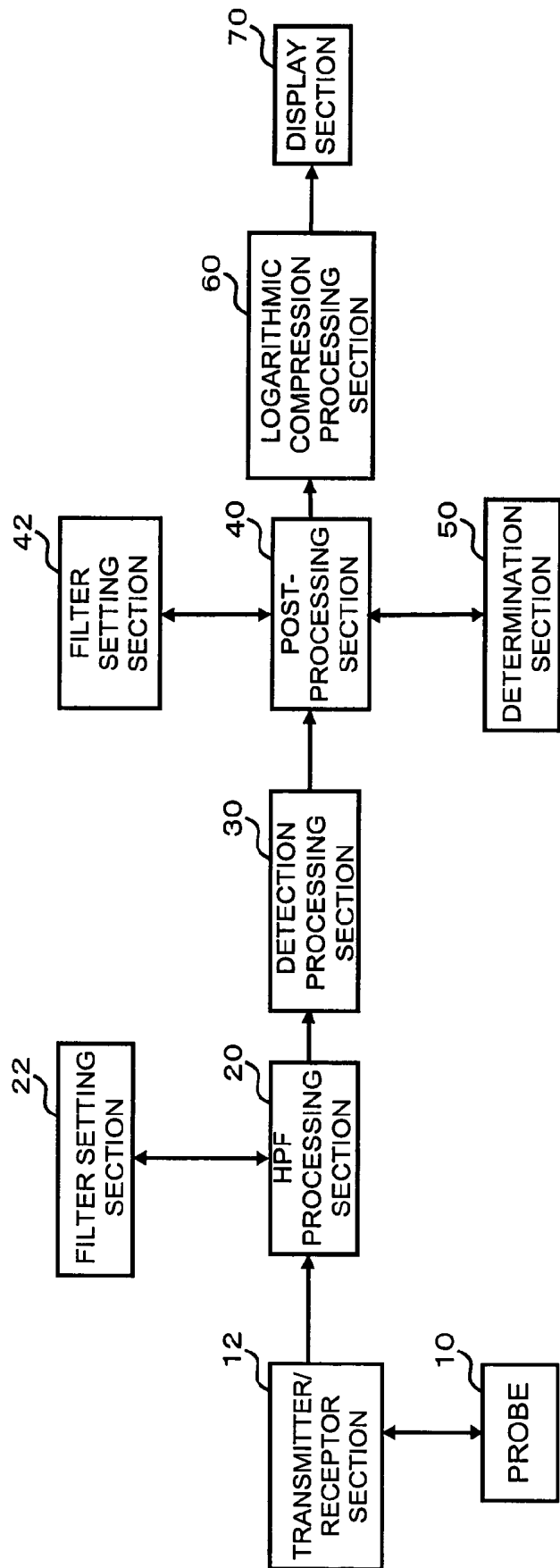
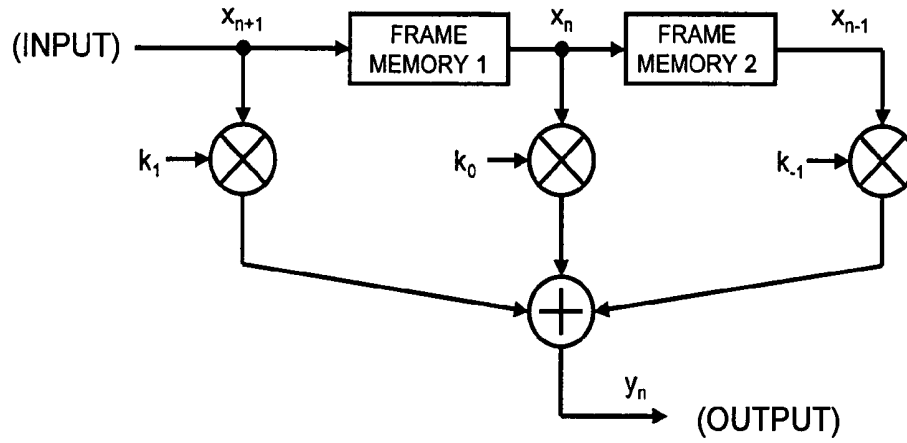

FIG. 1

<A> 3-TAP FIR FILTER



 2-TAP FIR FILTER

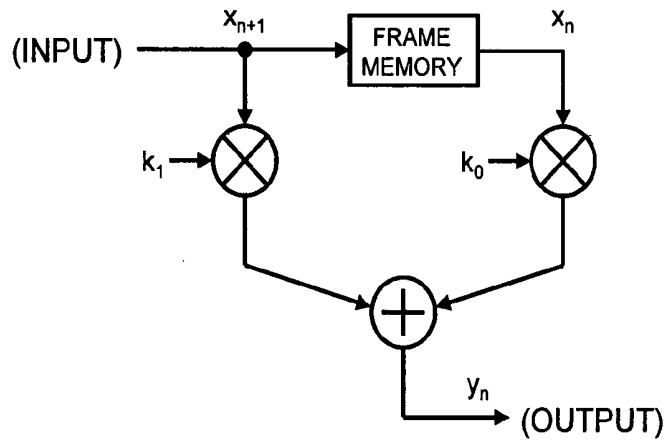

FIG. 2

<HPF FREQUENCY CHARACTERISTICS (3-TAP FIR FILTER)>

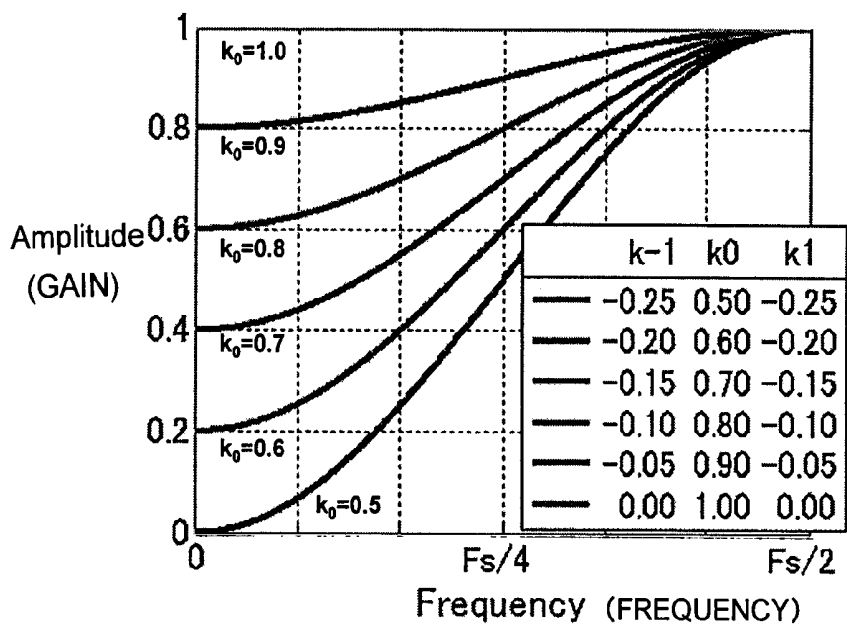

FIG. 3

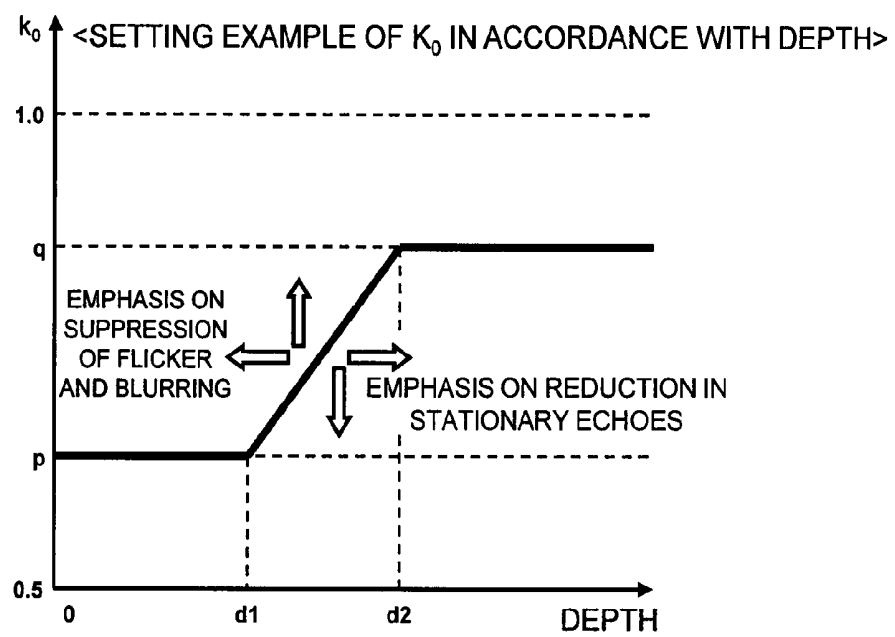

FIG. 4

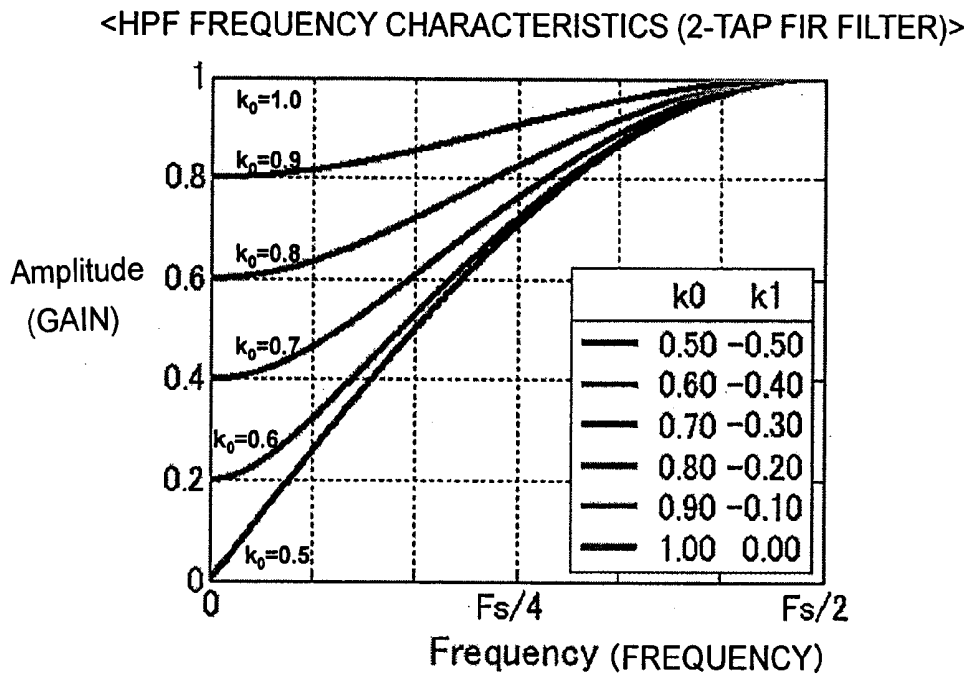

FIG. 5

<LPF FREQUENCY CHARACTERISTICS (2-TAP FIR FILTER)>

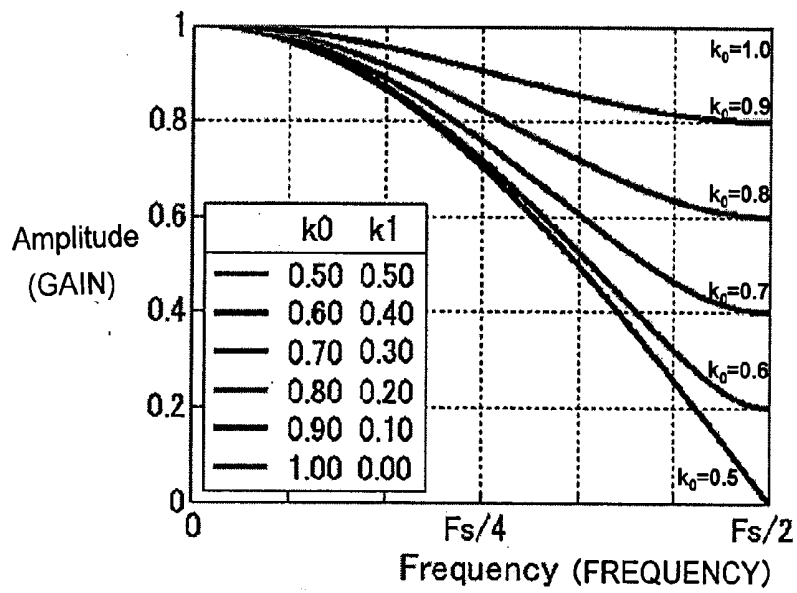

FIG. 6

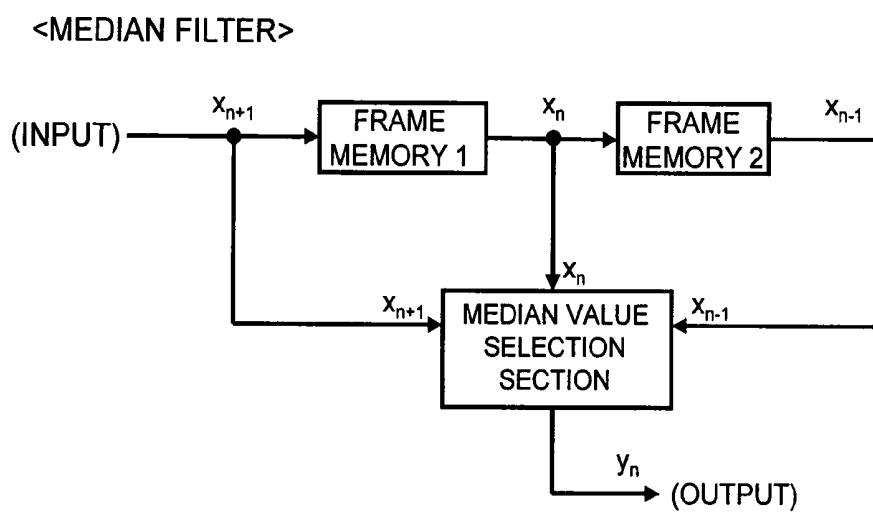

FIG. 7

<50: DETERMINATION SECTION>

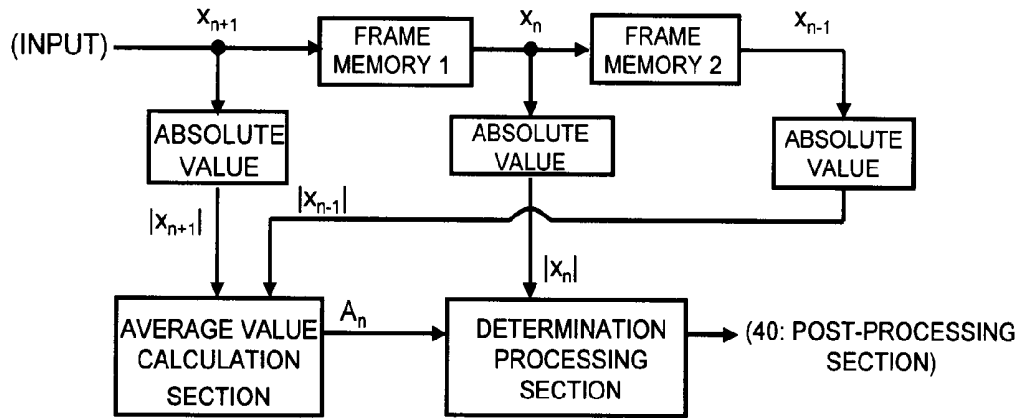

FIG. 8

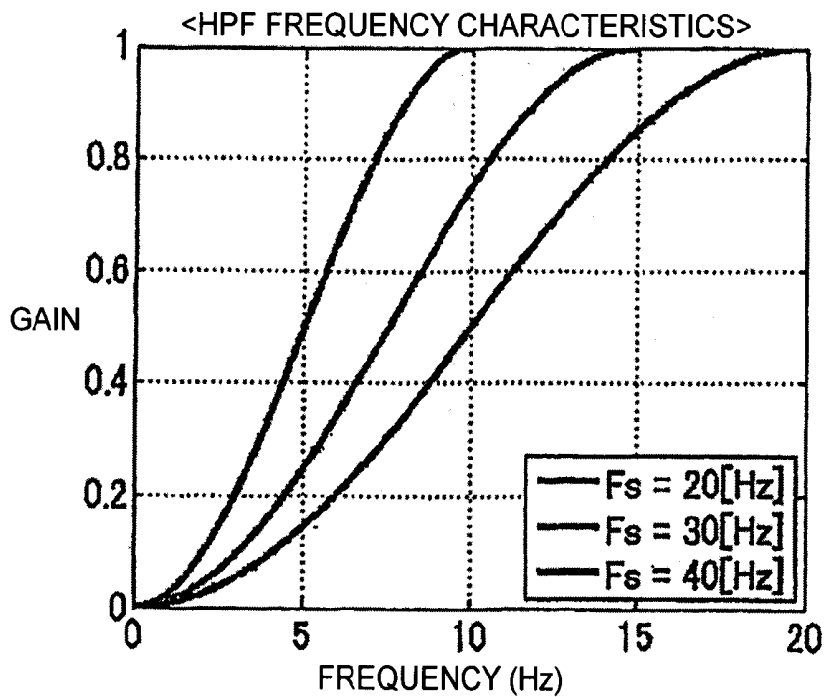

FIG. 9

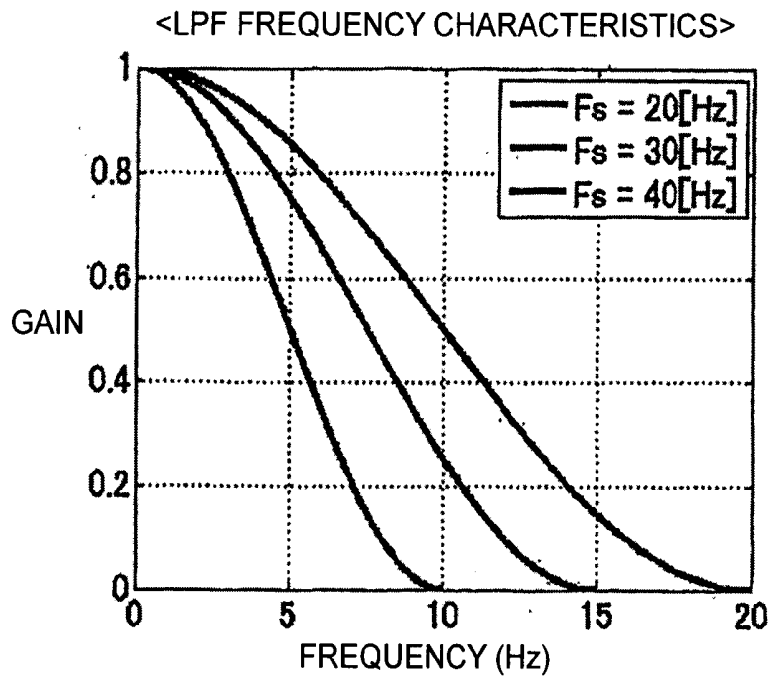

FIG. 10

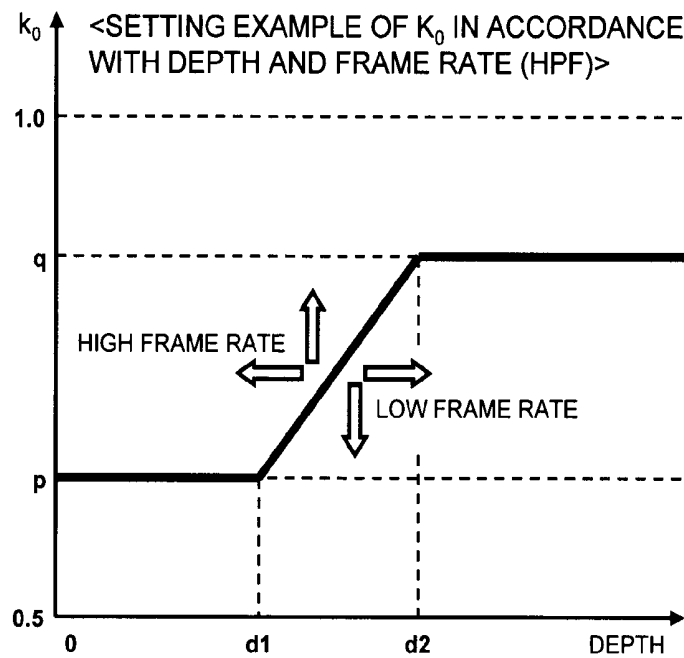

FIG. 11

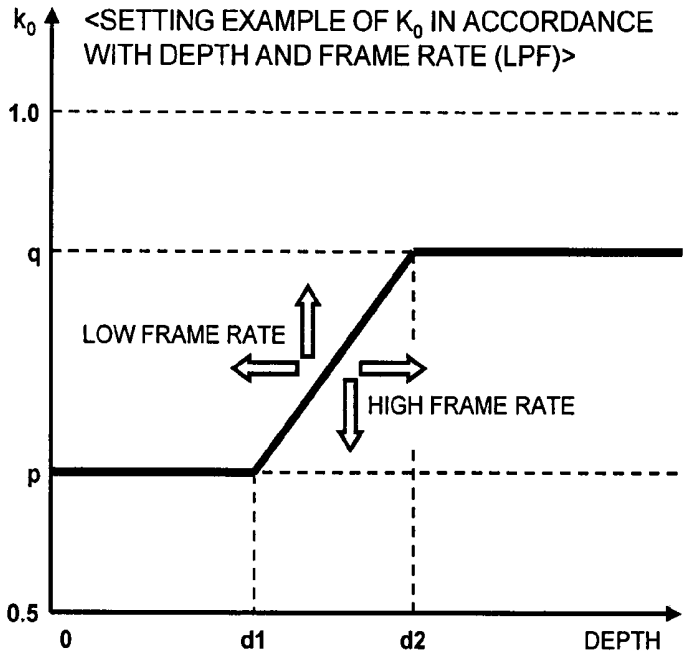

FIG. 12

DIAGNOSTIC ULTRASOUND APPARATUS

TECHNICAL FIELD

[0001] The present invention relates to an ultrasonic diagnostic apparatus, and more particularly to a technology of improving image quality of an ultrasonic image.

BACKGROUND ART

[0002] Ultrasonic diagnostic apparatuses, which are being widely used for diagnosis of organs, blood vessels, and fetuses, have played a significant role in diagnosis of heart conditions, for example. Use of an ultrasonic diagnostic apparatus enables observation of a beating heart, for example, in an ultrasonic moving image.

[0003] During ultrasonic diagnosis of heart conditions, fixed echoes (stationary echoes) are generated in an ultrasonic image due to the chest wall, ribs, pericardium, and so on, that are present on a superficial side (toward the probe) with respect to the heart. These stationary echoes cause deterioration of the quality of an ultrasonic image in ultrasonic diagnosis targeted on the heart. There have therefore conventionally been proposed methods of reducing these stationary echoes.

[0004] Patent Document 1, for example, proposes technology of applying a high-pass filter (HPF) to frame data obtained by transmitting and receiving ultrasound, along an arrangement direction of a plurality of frames, i.e. applying HPF processing between frames (inter-frame HPF processing), to thereby reduce stationary echoes whose fluctuations concerning the arrangement direction (time direction) of the plurality of frames are smaller than those of the heart.

[0005] With the simple inter-frame HPF processing, however, as it is difficult to completely maintain echoes from the heart with only the stationary echoes being completely removed, residual stationary echoes are partially generated, or loss of echoes from the heart occurs, resulting in generation of flicker within the moving image. Further, processing corresponding to weighted summation between a plurality of frames in the inter-frame HPF processing causes a problem that a heart valve or the like which moves at a high speed appears double or triple in the moving image, and also a problem that the borderline of the heart (cardiac muscle) becomes blurred.

[0006] Patent Document 2, for example, proposes technology of further performing inter-frame LPF (low-pass filter) processing after the inter-frame HPF processing in order to reduce the flicker described above. In other words, smoothing (flattening) between the frames is performed by the LPF processing to thereby reduce the flicker. This technology, however, suffers from a further problem that the inter-frame LPF processing, when simply performed for a whole image, makes the whole image blurred.

[0007] Patent Document 3, for example, proposes technology of increasing the weight of frame data after HPF processing in a superficial region in which a large number of stationary echoes are present and increasing the weight of frame data before the HPF processing in a deep region in which the heart exists, so that weighted summation is applied to frame data before and after the HPF processing, in order to suppress the flicker and blurring described above. With this technology, the stationary echoes are reduced in the superficial region while flicker and blurring relating to the heart are suppressed in the deep region. However, this technology also causes a

problem with respect to circuit scale, such as a problem that a circuit structure for applying weighted summation is necessary, for example.

PRIOR ART DOCUMENTS

Patent Documents

- [0008]** Patent Document 1: JP H8-107896 A
- [0009]** Patent Document 2: JP 2000-139909 A
- [0010]** Patent Document 3: JP 2005-288021 A

DISCLOSURE OF THE INVENTION

Technical Problems

[0011] In view of the background art described above, the present inventor has for many years studied and developed technology of improving the quality of an ultrasonic image including a moving subject to be diagnosed such as a heart, for example, and has, in particular, paid attention to filter processing along the arrangement direction of a plurality of frames.

[0012] The present invention has been made in the process of such study and development and is aimed at realizing an improved technology related to filter processing along the arrangement direction of a plurality of frames.

Solution to Problems

[0013] In order to achieve the above object, there is provided an ultrasonic diagnostic apparatus, including a probe that transmits and receives ultrasound; a transmitter/receiver section that controls the probe to thereby obtain a reception signal of ultrasound; a filter processing section that applies filter processing to frame data obtained based on the reception signal of ultrasound along an arrangement direction of a plurality of frames; and an image forming section that forms an ultrasonic image based on the frame data having been subjected to the filter processing, wherein the filter processing section applies a high-pass filter, having an offset level set in accordance with a depth within a frame, to frame data at the depth, thereby performing the filter processing.

[0014] In the above ultrasonic diagnostic apparatus, a high-pass filter having an offset level set in accordance with a depth within a frame is applied to frame data at the corresponding depth. The offset of a high-pass filter refers to boosting gain characteristics of the high-pass filter, and the offset level is defined by a gain value of the filter at the lower limit (e.g., 0 Hz) of the frequency band which is a target of processing by the high-pass filter, for example.

[0015] The offset level can be adjusted to a desired level relatively easily in a digital filter, for example, by changing a filter coefficient and so on. Therefore, according to the ultrasonic diagnostic apparatus described above, in order to improve the quality of an ultrasonic image by filter processing along the arrangement direction of a plurality of frames, it is possible to adjust the characteristics of the high-pass filter with relative ease in accordance with the depth.

[0016] In a preferred specific example, the filter processing section subjects frame data of a deep region including a moving subject to be diagnosed to a high-pass filter having an offset level set to a higher level than frame data of a superficial region.

[0017] In a preferred specific example, the filter processing section applies a high-pass filter having an offset level set to

a higher level as the depth within a frame becomes greater, and having characteristics closer to characteristics of an all-pass filter as the depth within a frame becomes greater.

[0018] In a preferred specific example, the ultrasonic diagnostic apparatus further includes a post-processing section that applies a low-pass filter or a median filter to the frame data processed by the filter processing section along the arrangement direction of the plurality of frames.

[0019] In a preferred specific example, the post-processing section, in a case of applying a low-pass filter, applies a low-pass filter, having an offset level set in accordance with a depth within a frame, to frame data at the depth.

[0020] In a preferred specific example, the post-processing section, in a case of applying a median filter, applies a median filter exclusively to frame data of a superficial region which is different from a deep region including a moving subject to be diagnosed.

[0021] In a preferred specific example, the ultrasonic diagnostic apparatus further includes a determination section that confirms a change of the frame data processed by the filter processing section at each of locations within a frame along the arrangement direction of the plurality of frames, to thereby determine whether or not the processing performed by the post-processing section is necessary at a corresponding location.

[0022] In a preferred specific example, the filter processing section applies a digital high-pass filter, having a filter coefficient set in accordance with a frame rate of frame data and a depth of frame data within a frame, to the frame data.

Advantageous Effects of Invention

[0023] According to the present invention, an improved technology related to filter processing along the arrangement direction of a plurality of frames is realized. For example, in accordance with a preferred aspect of the present invention, it is possible to adjust the characteristics of a high-pass filter with relative ease in accordance with the depth. Further, in accordance with another preferred aspect of the present invention, application of a digital high-pass filter having a filter coefficient set in accordance with a frame rate can suppress fluctuations of processing results of the digital high-pass filter in accordance with a frame rate.

BRIEF DESCRIPTION OF THE DRAWINGS

[0024] FIG. 1 Diagram illustrating an overall structure of a preferable ultrasonic diagnostic apparatus in an embodiment of the present invention

[0025] FIG. 2 Diagram illustrating a specific example of a digital filter.

[0026] FIG. 3 Diagram illustrating frequency characteristics of a HPF formed of a 3-tap FIR filter.

[0027] FIG. 4 View illustrating an example setting of a filter coefficient k_0 in accordance with a depth.

[0028] FIG. 5 Diagram illustrating frequency characteristics of a HPF formed of a 2-tap FIR filter.

[0029] FIG. 6 Diagram illustrating frequency characteristics of a LPF formed of a 2-tap FIR filter.

[0030] FIG. 7 Diagram illustrating a specific example of a median filter.

[0031] FIG. 8 Diagram illustrating a specific example of a determination section.

[0032] FIG. 9 Diagram illustrating change of the frequency characteristics of a HPF in accordance with a frame rate.

[0033] FIG. 10 Diagram illustrating change of the frequency characteristics of a LPF in accordance with a frame rate.

[0034] FIG. 11 View illustrating an example setting (HPF) of a filter coefficient k_0 in accordance with a depth and a frame rate.

[0035] FIG. 12 View illustrating an example setting (LPF) of a filter coefficient k_0 in accordance with a depth and a frame rate.

BEST MODE FOR CARRYING OUT THE INVENTION

[0036] FIG. 1 is a diagram illustrating an overall structure of an ultrasonic diagnostic apparatus which is preferable in an embodiment of the present invention (which will be hereinafter referred to as the present ultrasonic diagnostic apparatus). A probe **10** transmits ultrasound to a diagnostic region including a tissue to be diagnosed, and receives ultrasound reflected from the diagnostic region. The probe **10** includes a plurality of transducer elements for transmitting and receiving ultrasound, and the plurality of transducer elements are transmission-controlled by a transmitter/receiver section **12**, which forms a transmission beam. The plurality of transducer elements also receive ultrasound reflected from the diagnostic region. A signal obtained by reception of the ultrasound is output to the transmitter/receiver section **12**, which then forms a reception beam.

[0037] The transmitter/receiver section **12** outputs transmission signals corresponding to the plurality of transducer elements, respectively, of the probe **10**, thereby forming a transmission beam of ultrasound and scanning the transmission beam. Further, the transmitter/receiver section **12** applies phase alignment and summation processing and other processing to reception signals obtained from the respective plurality of transducer elements of the probe **10**, thereby forming a reception beam corresponding to the transmission beam which is scanned, and outputting echo data (reception signal) obtained along the reception beam.

[0038] The transmitter/receiver section **12** scans ultrasonic beams (a transmission beam and a corresponding reception beam) within a two-dimensional plane and collects echo data, thereby obtaining frame data forming a frame corresponding to the two-dimensional plane. The transmitter/receiver section **12** repeats scanning of the ultrasonic beams within the two-dimensional plane to thereby obtain frame data for a plurality of frames. The frame data thus obtained is stored in a memory, for example, and is read from the memory for processing by a HPF processing section **20** on the downstream side, for example.

[0039] The present ultrasonic diagnostic apparatus is suitable for diagnosis of a moving tissue such as the heart, for example, and is provided with a function to improve the quality of an ultrasonic image including a subject to be diagnosed, such as the heart. More specifically, the present ultrasonic diagnostic apparatus reduces fixed echoes (stationary echoes) associated with the chest wall, ribs, pericardium, and so on, that are present on a superficial side (toward the probe **10**) with respect to the heart, thereby improving the quality of the ultrasonic image.

[0040] The HPF (high-pass filter) processing section **20** performs filter processing of the frame data obtained for the plurality of frames in order to reduce the stationary echo. The HPF processing section **20** applies a high-pass filter along the arrangement direction of the plurality of frames, i.e. applies

inter-frame HPF processing, to the frame data, thereby reducing stationary echoes whose fluctuations in the arrangement direction of the plurality of frames (time direction) are smaller than those of the heart.

[0041] In an ultrasonic image, there are more stationary echoes present in a superficial region than in a deep region containing heart. Accordingly, the HPF processing section 20 performs filter processing by applying a high-pass filter, having characteristics set in accordance with a depth in a frame, to frame data at the corresponding depth. The high-pass filter can be implemented by a digital filter, for example, and a filter setting section 22 sets a filter coefficient and so on of the digital filter to thereby adjust the characteristics of the high-pass filter.

[0042] FIG. 2 is a diagram illustrating a specific example digital filter. The frame data is subjected to filter processing along the arrangement direction of the plurality of frames. More specifically, concerning frame data at a certain location (coordinates) within a frame, frame data at the same location is sequentially subjected to filter processing through the plurality of frames.

[0043] FIG. 2<A> illustrates a FIR filter with 3 taps (3-tap FIR filter). The frame data of the plurality of frames is sequentially input to this 3-tap FIR filter. In FIG. 2<A>, x_{n-1} , x_n , and x_{n+1} denote frame data at the same location (coordinates) within the frame, that can be obtained from three consecutive frames.

[0044] Frame data of one frame input to the 3-tap FIR filter is stored in a frame memory 1. Then, when frame data of a new one frame is input, the frame data stored in the frame memory 1 is now stored in a frame memory 2 in the following stage, and the newly input frame data of one frame is stored in the frame memory 1 in the previous stage. In this manner, each time frame data of new one frame is input, frame data stored in the frame memory 1 in the previous stage is sequentially shifted to the frame memory 2 in the following stage. In FIG. 2<A>, x_n denotes frame data of a noted frame; x_{n-1} denotes frame data obtained from the one frame previous to the frame of the frame data x_n , and x_{n+1} denotes frame data obtained from one frame after the frame of the frame data x_n .

[0045] The 3-tap FIR filter multiplies each of the three frame data obtained from the three consecutive frames by a filter coefficient and further adds the three data items after multiplication together. More specifically, in FIG. 2<A>, each of the frame data x_{n-1} , x_n , and x_{n+1} is multiplied by filter coefficients k_{-1} , k_0 , and k_1 , respectively, and the resulting three data items after the multiplication are further added to output the result of filter processing for the noted frame $y_n = k_{-1}x_{n-1} + k_0x_n + k_1x_{n+1}$.

[0046] FIG. 2 illustrates a FIR filter with 2 taps (2-tap FIR filter). In the case of a 2-tap FIR filter, similar to the case of the 3-tap FIR filter, frame data concerning a plurality of frames is sequentially input and frame data of one frame is stored in a frame memory. In FIG. 2, x_n denotes frame data of a noted frame, and x_n and x_{n+1} denote frame data at the same location within the frame, that can be obtained from two consecutive frames.

[0047] In the case of the 2-tap FIR filter, as in the case of the 3-tap FIR filter, each of the frame data x_n and x_{n+1} is multiplied by each of filter coefficients k_0 and k_1 and the resulting two data items after the multiplication are further added to output the result of filter processing concerning the noted frame $y_n = k_0x_n + k_1x_{n+1}$.

[0048] With the present ultrasonic diagnostic apparatus, for example, a high-pass filter is realized with the 3-tap FIR filter or 2-tap FIR filter illustrated in FIG. 2, and the characteristics of the high-pass filter are adjusted by adjusting the filter coefficient. While FIG. 2 illustrates 2-tap and 3-tap FIR filters as specific digital filter examples, a filter with 4 or more taps may also be used. Also, an IIR filter may be used in place of a FIR filter.

[0049] Concerning the 3-tap FIR filter illustrated in FIG. 2, if the filter coefficient is set that satisfies the following conditions (1-1) and (1-2) in which filter coefficients are symmetrical ($k_{-1}=k_1$), the gain characteristics increase monotonically with respect to the frequency, and the gain at the highest frequency is 0 [dB], a high-pass filter (HPF) exhibiting the characteristics illustrated in FIG. 3 is obtained.

[Expression 1]

$$-0.25 \leq k_1 \leq 0, 0.5 \leq k_0 \leq 1 \quad (1-1)$$

$$|k_{-1}| + |k_0| + |k_1| = 1 \quad (1-2)$$

[0050] FIG. 3 illustrates frequency characteristics of a HPF formed of the 3-tap FIR filter (FIG. 2). In FIG. 3, the horizontal axis shows the frequency, in which F_s denotes a frame rate, i.e., a sampling frequency of frame data. The vertical axis shows gain of the filter. In FIG. 3, k_{-1} , k_0 , and k_1 are filter coefficients of the 3-tap FIR filter (FIG. 2).

[0051] According to the frequency characteristics illustrated in FIG. 3, the offset level of the HPF changes in accordance with the filter coefficient. The offset of the HPF refers to boosting the gain characteristics of the HPF. In FIG. 3, the gain value of the filter at 0 Hz which is the lower limit of the frequency band to be processed with the HPF is defined as the offset level.

[0052] In FIG. 3, when the filter coefficient for the center tap k_0 is 0.5, the offset level is minimum, 0, and the suppression efficiency on the low frequency side, i.e. the effect of suppressing stationary echoes, is the greatest. As the filter coefficient k_0 increases from 0.5, the offset level also increases and the suppression effect of stationary echoes gradually decreases. Then, the offset level is the maximum, 1, when the filter coefficient k_0 is 1.0, and no suppression effect on the lower frequency side, i.e. no suppression effect of stationary echoes, can be obtained, showing filter characteristics of an all-pass filter in which an input signal is output as it is.

[0053] According to the present ultrasonic diagnostic apparatus, the offset level of the HPF is set in accordance with the depth of the frame data within a frame. Specifically, the filter setting section 22 in FIG. 1 controls the filter coefficient k_0 in the HPF processing section 20 such that the greater the depth, the higher the offset level set.

[0054] FIG. 4 illustrates a setting example of the filter coefficient k_0 in accordance with the depth. In FIG. 4, the horizontal axis shows the depth and the vertical axis shows the value of the filter coefficient k_0 . The depth refers to a depth of frame data to be processed by the filter within a frame.

[0055] In the setting example illustrated in FIG. 4, in the superficial portion from the depth of 0 (proximate the probe 10) to the depth of d_1 , the value of the filter coefficient k_0 is set to p ($0.5 \leq p < 1.0$). As the depth increases from d_1 to d_2 , the value of the filter coefficient k_0 is increased, and in the depth portion at the depth d_2 or a greater depth, the value of the filter coefficient k_0 is set to q ($p < q \leq 1.0$). The value of the filter coefficient k_0 may be smoothly changed at the depth d_1 and in

the vicinity thereof and at the depth d2 and in the vicinity thereof. Further, the value of the filter coefficient k_0 may be varied as necessary in the superficial portion from the depth of 0 to the depth of d1 and also in the deep portion at the depth d2 and greater depths. It is also possible to adjust the positions of the depth d1 and the depth d2 as appropriate, to thereby make the change of the filter coefficient k_0 in accordance with the depth steep or moderate.

[0056] Further, if it is desired to place importance on the effect of reducing the stationary echoes in the superficial region, the characteristics of the filter coefficient k_0 illustrated in FIG. 4 can be shifted to the direction of greater depth as a whole or in the direction of smaller k_0 value as a whole. Of course, the shifts in both directions can be performed together. Also, if it is desired to place importance on the effect of suppressing flicker and blurring, the characteristics of the filter coefficient k_0 illustrated in FIG. 4 can be shifted to the direction of smaller depth as a whole or in the direction of greater k_0 value as a whole. Of course, the shifts in both directions can be performed together.

[0057] If a 2-tap FIR filter is used in place of a 3-tap FIR filter, the circuit configuration or the like can be further simplified. For example, concerning the 2-tap FIR filter illustrated in FIG. 2, if the filter coefficient is set that satisfies the following conditions (2-1) and (2-2) in which the gain characteristics increase monotonically with respect to the frequency, and the gain at the highest frequency is 0 [dB], a high-pass filter (HPF) exhibiting the characteristics illustrated in FIG. 5 is obtained.

[Expression 2]

$$0.5 \leq k_0 \leq 1, 0.5 \leq k_1 \leq 0 \quad (2-1)$$

$$|k_0| + |k_1| = 1 \quad (2-2)$$

[0058] FIG. 5 illustrates frequency characteristics of a HPF formed of the 2-tap FIR filter (FIG. 2). As in the case illustrated in FIG. 3, in FIG. 5, the horizontal axis similarly shows the frequency, in which F_s denotes a frame rate, i.e., a sampling frequency of frame data. The vertical axis similarly shows the gain of the filter. In FIG. 5, k_0 and k_1 are filter coefficients of the 2-tap FIR filter (FIG. 2). In the frequency characteristics illustrated in FIG. 5, as in the case in FIG. 3, the offset level of the HPF varies in accordance with the filter coefficient.

[0059] More specifically, assuming that the gain value of the filter at 0 Hz, which is the lower limit of the frequency band to be processed with the HPF, is defined as the offset level, in FIG. 5, as in FIG. 4, when the filter coefficient k_0 is 0.5, the offset level is minimum, 0, and the suppression efficiency on the low frequency side, i.e. the effect of suppressing stationary echoes, is the greatest. As the filter coefficient k_0 increases from 0.5, the offset level also increases and the suppression effect of stationary echoes gradually decreases. Then, the offset level is the maximum, 1, when the filter coefficient k_0 is 1.0, and no suppression effect on the lower frequency side, i.e. no suppression effect of stationary echoes, can be obtained, showing filter characteristics of an all-pass filter.

[0060] In the case of a 2-tap FIR filter, as in the case of a 3-tap FIR filter, the offset level of the HPF is set in accordance with the depth of the frame data within a frame. Specifically, the filter setting section 22 in FIG. 1 controls the filter coefficient k_0 such that the greater the depth, the higher the offset

level set. For this control, the setting example of the filter coefficient k_0 , which has been described with the use of FIG. 4, can be applied.

[0061] With the use of the high-pass filter which has been described with reference to FIGS. 2 to 5, it is possible to achieve both reduction in the stationary echoes and suppression of flicker and blurring simultaneously, with a relatively simple structure, i.e. without the need to provide a complicated circuit structure (see Patent Document 3, for example) such as for weighted summation processing.

[0062] Referring back to FIG. 1, the frame data of a plurality of frames having been subjected to the inter-frame HPF processing in the HPF processing section 20 is first subjected to detection processing in a detection processing section 30 and then transmitted to a post-processing section 40. In the detection processing section 30, known detection processing is executed.

[0063] While reduction of the stationary echoes and suppression of flicker and blurring in an image has been already realized by the processing in the HPF processing section 20, with the present ultrasonic diagnostic apparatus, it is possible to further suppress the flicker in an image by the post-processing section 40. The post-processing section 40 applies a low-pass filter or a median filter to the frame data, along the arrangement direction of the plurality of frames.

[0064] If the post-processing section 40 uses a low-pass filter (LPF), the low-pass filter can be implemented by the 3-tap FIR filter or the 2-tap FIR filter illustrated in FIG. 2. Of course, a filter with 4 or more taps may be used or an IIR filter may be used in place of an FIR filter. For example, concerning the 2-tap FIR filter illustrated in FIG. 2, if the filter coefficient is set that satisfies the following conditions (3-1) and (3-2) in which the gain characteristics decrease monotonically with respect to the frequency, and the gain of DC components (frequency 0 Hz components) is 0 [dB], a low pass filter (LPF) exhibiting the characteristics illustrated in FIG. 6 is obtained.

[Expression 3]

$$0.5 \leq k_0 \leq 1 \quad (3-1)$$

$$k_0 + k_1 = 1 \quad (3-2)$$

[0065] FIG. 6 illustrates frequency characteristics of a LPF formed of the 2-tap FIR filter (FIG. 2). In FIG. 6, the horizontal axis shows the frequency, in which F_s denotes a frame rate, i.e., a sampling frequency of frame data. The vertical axis shows the gain of the filter. In FIG. 6, k_0 and k_1 are filter coefficients of the 2-tap FIR filter (FIG. 2).

[0066] In the frequency characteristics illustrated in FIG. 6, the offset level changes in accordance with the filter coefficient. The offset of LPF refers to boosting the gain characteristics of the LPF. In FIG. 6, the gain value of a filter at $F_s/2$ Hz, which is the upper limit of the frequency band to be processed with the LPF, i.e. at a frequency which is a half the sampling frequency, is defined as the offset level.

[0067] In FIG. 6, when the filter coefficient k_0 is 0.5, the offset level is minimum, 0, and the suppression efficiency on the high frequency side, i.e. the smoothing effect, is the greatest. With the increase in the smoothing effect in the arrangement direction of a plurality of frames, the suppression effect of flicker is also increased. Then, as the filter coefficient k_0 increases from 0.5, the offset level increases and the smoothing effect gradually decreases. Then, when the filter coefficient k_0 is 1.0, the offset level is the maximum, 1, and no suppression effect on the higher frequency side, i.e. no

smoothing effect, can be obtained, showing filter characteristics of an all-pass filter in which an input signal is output as it is.

[0068] In the present ultrasonic diagnostic apparatus, the offset level of the LPF is set in accordance with the depth of the frame data within a frame. Specifically, a filter setting section **42** in FIG. **1** controls the filter coefficient k_0 in the post-processing section **40** such that the greater the depth, the higher the offset level set. For this control, the setting example of the filter coefficient k_0 , which has been described with the use of FIG. **4**, can be applied.

[0069] If the post-processing section **40** uses a median filter, a median filter having a structure illustrated in FIG. **7**, for example, is used. FIG. **7** illustrates a specific example median filter. Frame data of a plurality of frames is sequentially input to this median filter. In FIG. **7**, x_n is frame data of a noted frame. Further, x_{n-1} , x_n , and x_{n+1} denote frame data at the same location (coordinates) within the frame, that can be obtained from three consecutive frames.

[0070] Frame data of one frame input to the median filter is stored in a frame memory 1. Then, when frame data of a new one frame is input, the frame data stored in the frame memory 1 is now stored in a frame memory 2 in the following stage, and the newly input frame data of one frame is stored in the frame memory 1 in the previous stage. In this manner, each time frame data of new one frame is input, frame data stored in the frame memory 1 in the previous stage is sequentially shifted to the frame memory 2 in the following stage. In FIG. **7**, x_{n-1} denotes frame data obtained from the one previous frame to the frame of the frame data x_n , and x_{n+1} denotes frame data obtained from one frame after the frame of the frame data x_n .

[0071] The median filter selects and outputs a median value of the three frame data obtained from three consecutive frames. More specifically, in FIG. **7**, the median filter selects data corresponding to a median value of x_{n-1} , x_n , and x_{n+1} , and outputs the selected data as a processing result y_n in the noted frame.

[0072] With the median filter, it is possible to suppress flicker while suppressing blurring in an image. Here, it is more desirable to apply a median filter locally to a superficial portion within the frame than to apply a median filter to a whole image. More specifically, it is desirable to give consideration to prevent generation of blurring in an image of a heart valve and the like by applying no median filter to a deep region in which the heart exists. For example, it is possible to set a threshold value of the depth and prevent application of a median filter to the frame data at a location which is deeper than the threshold value.

[0073] Further, a determination section **50** in FIG. **1** may determine whether or not the processing in the post-processing section **40** is necessary. In this case, concerning the frame data obtained via the detection processing section **30** after having been processed in the HPF processing section **20**, the determination section **50** confirms a change of the frame data in the arrangement direction of a plurality of frames at each location within the frame, thereby determining whether or not the processing in the post-processing section **40** is necessary at that location.

[0074] FIG. **8** illustrates a specific example of the determination section **50**. Frame data of a plurality of frames is sequentially input to the determination section **50**. In FIG. **8**,

x_{n-1} , x_n , and x_{n+1} denote frame data at the same location (coordinates) within the frame, that can be obtained from three consecutive frames.

[0075] Frame data of one frame input to the determination section **50** is stored in a frame memory 1. Then, when frame data of a new one frame is input, the frame data stored in the frame memory 1 is now stored in a frame memory 2 in the following stage, and the newly input frame data of one frame is stored in the frame memory 1 in the previous stage. In this manner, each time frame data of new one frame is input, frame data stored in the frame memory 1 in the previous stage is sequentially shifted to the frame memory 2 in the following stage. In FIG. **8**, x_n is frame data of a noted frame, x_{n-1} denotes frame data obtained from the one previous frame to the frame of the frame data x_n , and x_{n+1} denotes frame data obtained from one frame after the frame of the frame data x_n .

[0076] An average value calculation section calculates an average value A_n of absolute values of the frame data before and after the noted frame using the following equation, wherein M denotes the number of frames before or after the noted frame, which is $M=1$ in the specific example in FIG. **8**.

[Expression 4]

$$A_n = \frac{1}{2M} \sum_{m=1}^M (|x_{n-m}| + |x_{n+m}|) \quad (4)$$

[0077] A determination processing section compares an absolute value for the frame data of the noted frame with the average value A_n calculated in the average value calculation section, and determines, for the frame data of the noted frame, whether or not processing to suppress flicker is necessary, based on the conditions in the following expressions.

[Expression 5]

$$|x_n| - A_n \geq T_H \quad (5-1)$$

$$|x_n| - A_n / A_n \geq T_H \quad (5-2)$$

[0078] In the conditions (5-1) and (5-2), T_H is a threshold value used for determining flicker. If the condition (5-1) is satisfied, for example, it is determined that flicker suppression processing is necessary for the frame data x_n of the noted frame. Further, the condition (5-2) which is normalized by the average value A_n may be used in place of the condition (5-1).

[0079] Referring back to FIG. **1**, the post-processing section **40** executes flicker suppression processing for the frame data of the noted frame for which it is determined that flicker suppression processing is necessary in the determination section **50**, and does not execute flicker suppression processing for the frame data of the noted frame for which it is determined that flicker suppression processing is not necessary. When the flicker suppression processing is performed, the LPF which has been described with reference to FIG. **6** or the median filter which has been described with reference to FIG. **7**, for example, is applied. Further, the post-processing section **40** in FIG. **1** may output the average value A_n obtained by the expression (4), as a result of the flicker suppression processing for the frame data of the noted frame.

[0080] A logarithmic compression processing section **60** executes known logarithmic compression processing for the frame data of a plurality of frames obtained from the post-processing section **40**. The frame data of a plurality of frames

having been subjected to the logarithmic compression processing is then transmitted to a display section 70, and an ultrasonic image, which is a moving image expressing a beating heart, for example, is displayed on the display section 70. The post-processing section 40 may be provided downstream of the logarithmic compression processing section 60.

[0081] As described above, according to the present ultrasonic diagnostic apparatus, it is possible to achieve reduction of the stationary echoes and suppression of flicker and blurring of an image in the HPF processing section 20 and further suppress image flicker in the post-processing section 40. When performing this processing, the HPF processing section 20 uses a high-pass filter whose characteristics are set in accordance with the depth in a frame and the post-processing section 40 uses a low-pass filter whose characteristics are set in accordance with the depth in a frame. In other words, the characteristics of the high-pass filter and the low-pass filter are adjusted in accordance with the depth in a frame.

[0082] When the high-pass filter and the low-pass filter are implemented by a digital filter, while the filter characteristics of a digital filter are determined by adjusting setting of a filter coefficient and so on, the characteristics of a digital filter also depend on the sampling frequency of data to be processed. In filter processing along the arrangement direction of a plurality of frames, the sampling frequency of frame data to be processed changes depending on the frame rate. Accordingly, when a digital filter is used in filter processing along the arrangement direction of a plurality of frames, it is necessary to take into consideration the dependency of the characteristics of the digital filter on the frame rate.

[0083] The present ultrasonic diagnostic apparatus applies a digital filter having a filter coefficient set in accordance with a frame rate, to thereby suppress fluctuations of the results of filter processing in accordance with the frame rate.

[0084] FIG. 9 illustrates changes of the frequency characteristics of a HPF in accordance with the frame rate, and specifically shows that the frequency characteristics of a HPF formed of a 3-tap FIR filter (FIG. 2) change in accordance with the frame rate. In FIG. 9, the horizontal axis shows the frequency and the vertical axis shows gain of a filter. In the graph, F_s denotes a frame rate (frame frequency), i.e. a sampling frequency of the frame data. Further, the frequency characteristics illustrated in FIG. 9 are obtained at each frame rate F_s , with the filter coefficients k_{-1} , k_0 , and k_1 of the 3-tap FIR filter in FIG. 2 being set to -0.25 , 0.50 , and -0.25 , respectively.

[0085] On the other hand, FIG. 10 illustrates changes of the frequency characteristics of a LPF in accordance with the frame rate, and specifically shows that the frequency characteristics of a LPF formed of a 3-tap FIR filter (FIG. 2) change in accordance with the frame rate. In FIG. 10, the horizontal axis shows the frequency and the vertical axis shows gain of a filter. In the graph, F_s denotes a frame rate (frame frequency), i.e. a sampling frequency of the frame data. Further, the frequency characteristics illustrated in FIG. 10 are obtained at each frame rate F_s , with the filter coefficients k_{-1} , k_0 , and k_1 of the 3-tap FIR filter in FIG. 2 being set to 0.25 , 0.50 , and 0.25 , respectively.

[0086] As illustrated in FIGS. 9 and 10, in a digital filter, if the filter coefficient is fixed, the frequency characteristics vary in accordance with the level of the frame rate F_s . Specifically, there is a tendency for the frequency characteristics

to extend toward the frequency axis direction and the cutoff frequency to become higher as the frame rate F_s increases (becomes higher).

[0087] According to the present ultrasonic diagnostic apparatus, the filter coefficient of the digital filter illustrated in FIG. 2, for example, is adjusted in accordance with the level of the frame rate F_s which is set by a user operation, for example.

[0088] When the number of taps is fixed, the frequency characteristics of the HPF formed of the 3-tap FIR filter illustrated in FIG. 2, for example, are as shown in FIG. 3. FIG. 3 shows that as the filter coefficient k_0 increases from 0.5 , the offset level of the HPF also increases. Further, as the offset level increases, the cutoff frequency of the HPF decreases. As such, it is possible to decrease the cutoff frequency of the HPF by increasing the offset level.

[0089] On the other hand, as has been described with reference to FIG. 9, there is a tendency that as the frame rate F_s increases, the frequency characteristics of the HPF are extended toward the frequency axis direction and the cutoff frequency increases. Namely, there is a tendency for the cutoff frequency to increase as the frame rate F_s increases.

[0090] Accordingly, in order to suppress the tendency that, as the frame rate F_s increases, the cutoff frequency also increases, the filter coefficient is adjusted such that as the frame rate F_s increases, the offset level is increased and the cutoff frequency is lowered. This adjustment allows control to prevent a change of the cutoff frequency of the HPF in accordance with the change of the frame rate F_s as much as possible. The filter coefficient of the HPF used in the HPF processing section 20 in FIG. 1 is adjusted by the filter setting section 22.

[0091] Also, when the number of taps is fixed, the frequency characteristics of the LPF formed of the 2-tap FIR filter illustrated in FIG. 2, for example, are as shown in FIG. 6. FIG. 6 shows that as the filter coefficient k_0 increases from 0.5 , the offset level of the LPF also increases. Further, as the offset level increases, the cutoff frequency of the LPF increases. As such, it is possible to increase the cutoff frequency of the LPF by increasing the offset level.

[0092] On the other hand, as has been described with reference to FIG. 10, there is a tendency that as the frame rate F_s increases, the frequency characteristics of the LPF are extended toward the frequency axis direction and the cutoff frequency increases. Namely, there is a tendency for the cutoff frequency to increase as the frame rate F_s increases.

[0093] Accordingly, in order to suppress the tendency that, as the frame rate F_s increases, the cutoff frequency also increases, the filter coefficient is adjusted such that as the frame rate F_s increases, the offset level is decreased and the cutoff frequency is lowered. This adjustment allows control to prevent changes of the cutoff frequency of the LPF in accordance with the change of the frame rate F_s as much as possible. The filter coefficient of the LPF used in the post-processing section 40 in FIG. 1 is adjusted by the filter setting section 42.

[0094] Further, in addition to the filter coefficient, the number of taps of a filter may be adjusted. For example, if the frequency characteristics at the frame rate of 30 Hz are effective for reduction of the stationary echoes and suppression of flicker and blurring of an image in FIG. 9, the filter coefficient and the number of taps are adjusted so as to realize the frequency characteristics close to those at the frame rate of 30 Hz even when the frame rate is 40 Hz or 20 Hz. Specifically,

if the frame rate is increased from 30 Hz to 40 Hz, for example, the filter coefficient and the number of taps are adjusted such that the cutoff frequency at 40 Hz is not high (such that the cutoff frequency approaches that at 30 Hz) and simultaneously the frequency characteristics at 40 Hz are not gentle (the frequency characteristics approach those at 30 Hz).

[0095] Similarly, if the frequency characteristics at the frame rate of 30 Hz are effective for suppression of flicker in FIG. 10, the filter coefficient and the number of taps are adjusted so as to realize the frequency characteristics close to those at the frame rate of 30 Hz even when the frame rate is 40 Hz or 20 Hz.

[0096] Further, in order to establish both the control of the filter coefficient in accordance with the depth and the control of the filter coefficient in accordance with the frame rate in a HPF, the setting example illustrated in FIG. 11 can be considered. For example, in a case in which the characteristics of the filter coefficient k_0 in accordance with the depth are set at the reference frame rate (e.g. 30 Hz), when the frame rate is increased (to 40 Hz, for example), the characteristics of the filter coefficient k_0 of the HPF illustrated in FIG. 11 are shifted in a more superficial direction as a whole or in a direction in which the value of filter coefficient k_0 becomes larger as a whole. Of course, the shifts in both directions may be performed together. On the other hand, when the frame rate is decreased (to 20 Hz, for example), the characteristics of the filter coefficient k_0 of the HPF illustrated in FIG. 11 are shifted in a deeper direction as a whole or in a direction in which the value of filter coefficient k_0 becomes smaller as a whole. Of course, the shifts in both directions may be performed together.

[0097] Further, in order to establish both the control of the filter coefficient in accordance with the depth and the control of the filter coefficient in accordance with the frame rate in a LPF, the setting example illustrated in FIG. 12 can be considered. For example, in a case in which the characteristics of the filter coefficient k_0 in accordance with the depth are set at the reference frame rate (e.g. 30 Hz), when the frame rate is increased (to 40 Hz, for example), the characteristics of the filter coefficient k_0 of the LPF illustrated in FIG. 12 are shifted in a deeper direction as a whole or in a direction in which the value of filter coefficient k_0 becomes smaller as a whole. Of course, the shifts in both directions may be performed together. On the other hand, when the frame rate is decreased (to 20 Hz, for example), the characteristics of the filter coefficient k_0 of the LPF illustrated in FIG. 12 are shifted in a more superficial direction as a whole or in a direction in which the value of filter coefficient k_0 becomes larger as a whole. Of course, the shifts in both directions may be performed together.

[0098] With the above structure, it is possible to realize the reduction in the stationary echoes and the suppression of flicker and blurring of an image in the HPF processing section 20, and to further suppress flicker of the image in the post-processing section 40 while suppressing changes of the characteristics associated with the change of the frame rate.

[0099] The preferred embodiments of the present invention which have been described above are described only for the purpose of illustration, and do not limit the scope of the invention. The present invention may include various modifications without departing from the essence of the invention. The following are also preferable embodiments of the present invention.

Embodiment 1

[0100] An ultrasonic diagnostic apparatus, including a probe that transmits and receives ultrasound; a transmitter/receiver section that controls the probe to thereby obtain a reception signal of ultrasound; a filter processing section that applies filter processing to frame data obtained based on the reception signal of ultrasound along an arrangement direction of a plurality of frames; and an image forming section that forms an ultrasonic image based on the frame data having been subjected to the filter processing, wherein the filter processing section applies a high-pass filter having a filter coefficient set in accordance with a frame rate of frame data to the frame data, thereby performing the filter processing.

Embodiment 2

[0101] The ultrasonic diagnostic apparatus according to Embodiment 1, wherein the filter processing section applies a digital high-pass filter having a filter coefficient set such that the higher the frame rate, the higher the offset level.

Embodiment 3

[0102] The ultrasonic diagnostic apparatus according to Embodiment 1 or 2, wherein the filter processing section applies a digital high-pass filter having a greater number of taps as the frame rate increases.

Embodiment 4

[0103] The ultrasonic diagnostic apparatus according to any one of Embodiments 1 to 3, wherein the filter processing section applies a digital high-pass filter having a filter coefficient set in accordance with a frame rate of frame data and a depth of frame data within a frame to the frame data.

Embodiment 5

[0104] The ultrasonic diagnostic apparatus according to any one of Embodiments 1 to 4, further comprising a post-processing section that applies, to frame data having been processed in the filter processing section, a digital low-pass filter having a filter coefficient set in accordance with a frame rate along the arrangement direction of the plurality of frames.

Embodiment 6

[0105] The ultrasonic diagnostic apparatus according to Embodiment 5, wherein the post-processing section applies a digital low-pass filter having a filter coefficient set such that the lower the frame rate, the higher the offset level.

Embodiment 7

[0106] The ultrasonic diagnostic apparatus according to Embodiment 6, wherein the post-processing section applies a digital low-pass filter having a greater number of taps as the frame rate increases.

Embodiment 8

[0107] The ultrasonic diagnostic apparatus according to any one of Embodiments 5 to 7, wherein the post-processing section applies a digital low-pass filter, having a filter coefficient set in accordance with a frame rate of frame data and a depth of frame data within a frame, to the frame data.

REFERENCE SYMBOLS LIST

[0108] 10 probe, 12 transmitter/receiver section, 20 HPF processing section, 40 post-processing section, 50 determination section.

1. An ultrasonic diagnostic apparatus, comprising:
 - a probe that transmits and receives ultrasound;
 - a transmitter/receiver section that controls the probe to thereby obtain a reception signal of ultrasound;
 - a filter processing section that applies filter processing to frame data obtained based on the reception signal of ultrasound along an arrangement direction of a plurality of frames; and
 - an image forming section that forms an ultrasonic image based on the frame data having been subjected to the filter processing,
 wherein the filter processing section applies a high-pass filter, having an offset level set in accordance with a depth within a frame, to frame data at the depth, thereby performing the filter processing.
2. The ultrasonic diagnostic apparatus according to claim 1, wherein
 - the filter processing section applies a high-pass filter having an offset level set to a higher level for frame data of a deep region including a moving subject to be diagnosed, than for frame data of a superficial region.
3. The ultrasonic diagnostic apparatus according to claim 1, wherein
 - the filter processing section applies a high-pass filter having an offset level set to a higher level as the depth within a frame is greater and having characteristics closer to characteristics of an all-pass filter as the depth within a frame is greater.
4. The ultrasonic diagnostic apparatus according to claim 2, wherein
 - the filter processing section applies a high-pass filter having an offset level set to a higher level as the depth within a frame is greater and having characteristics closer to characteristics of an all-pass filter as the depth within a frame is greater.
5. The ultrasonic diagnostic apparatus according to claim 1, further comprising:
 - a post-processing section that applies a low-pass filter or a median filter to the frame data processed by the filter processing section along the arrangement direction of the plurality of frames.
6. The ultrasonic diagnostic apparatus according to claim 5, wherein
 - the post-processing section, in a case of applying a low-pass filter, applies a low-pass filter, having an offset level set in accordance with a depth within a frame, to frame data at the depth.
7. The ultrasonic diagnostic apparatus according to claim 5, wherein
 - the post-processing section, in a case of applying a median filter, applies a median filter exclusively to frame data of a superficial region which is different from a deep region including a moving subject to be diagnosed.
8. The ultrasonic diagnostic apparatus according to claim 5, further comprising:
 - a determination section that confirms a change of the frame data processed by the filter processing section at each of locations within a frame along the arrangement direction of the plurality of frames, to thereby determine whether or not the processing performed by the post-processing section is necessary at a corresponding location.
9. The ultrasonic diagnostic apparatus according to claim 1, wherein
 - the filter processing section applies a digital high-pass filter having a filter coefficient set in accordance with a frame rate of frame data and a depth of frame data within a frame to the frame data.
10. The ultrasonic diagnostic apparatus according to claim 9, wherein
 - the filter processing section applies a digital high-pass filter having a filter coefficient set such that the offset level is higher as the frame rate is higher.
11. The ultrasonic diagnostic apparatus according to claim 9, wherein
 - the filter processing section applies a digital high-pass filter having a larger number of taps as the frame rate is higher.
12. The ultrasonic diagnostic apparatus according to claim 10, wherein
 - the filter processing section applies a digital high-pass filter having a larger number of taps as the frame rate is higher.
13. The ultrasonic diagnostic apparatus according to claim 5, wherein
 - the post-processing section, in a case of applying a low-pass filter, applies a digital low-pass filter, having a filter coefficient set in accordance with a frame rate of frame data and a depth of frame data within a frame, to the frame data.
14. The ultrasonic diagnostic apparatus according to claim 13, wherein
 - the post-processing section applies a digital low-pass filter having a filter coefficient set such that the offset level is higher as the frame rate is lower.
15. The ultrasonic diagnostic apparatus according to claim 13, wherein
 - the post-processing section applies a digital low-pass filter having a larger number of taps as the frame rate is higher.

* * * * *

专利名称(译)	诊断超声设备		
公开(公告)号	US20150016744A1	公开(公告)日	2015-01-15
申请号	US14/380290	申请日	2013-02-19
[标]申请(专利权)人(译)	日立阿洛卡医疗株式会社		
申请(专利权)人(译)	日立ALOKA MEDICAL. , LTD.		
当前申请(专利权)人(译)	HITACHI , LTD.		
[标]发明人	TSAO JING WEN YOSHIZAWA SHINGO		
发明人	TSAO, JING-WEN YOSHIZAWA, SHINGO		
IPC分类号	G06T5/00 A61B8/08		
CPC分类号	G06T5/003 A61B8/5223 A61B8/5207 G06T2207/10132 G06T2207/20024 G06T2207/10016 A61B8/0883 A61B8/5269 G01S7/52026 G01S7/52077		
优先权	2012045280 2012-03-01 JP 2012045282 2012-03-01 JP		
其他公开文献	US9514521		
外部链接	Espacenet USPTO		

摘要(译)

在超声图像中，在包括心脏的深部区域表面区域中存在许多固定回波。在本发明中，HPF处理单元（20）通过应用高通滤波器对帧数据进行滤波，所述高通滤波器的特性已经根据帧中的深度设置在所述帧数据上。深度。例如，可以利用数字滤波器实现高通滤波器，并且通过设置所述数字滤波器的滤波器系数的滤波器设置单元（22）来调整高通滤波器的特性。也就是说，HPF处理单元中的滤波器系数（20）由滤波器设置单元（22）控制，因此区域越深，越高偏移级别已设置。

