



US006858009B2

(12) **United States Patent**
Kawata et al.

(10) **Patent No.:** **US 6,858,009 B2**
(45) **Date of Patent:** **Feb. 22, 2005**

(54) **ULTRASONIC ANGIOSCOPE SYSTEM**

5,651,366 A * 7/1997 Liang et al. 600/439
6,022,309 A * 2/2000 Celliers et al. 600/7
6,309,352 B1 * 10/2001 Oraevsky et al. 600/407

(75) Inventors: **Satoshi Kawata**, Osaka (JP); **Tadao Sugiura**, Osaka (JP); **Osamu Ohshiro**, Nara (JP); **Kunihiro Chihara**, Osaka (JP)

FOREIGN PATENT DOCUMENTS

JP 8-168490 7/1996
JP 11-128229 5/1999

(73) Assignee: **Japan Science and Technology Corporation**, Kawaguchi (JP)

OTHER PUBLICATIONS

(*) Notice: Subject to any disclaimer, the term of this patent is extended or adjusted under 35 U.S.C. 154(b) by 0 days.

Acta Polytechnica Scandinavia, Applied Physics Series, No. 193, (1994), (Finland), pp. 1 to 32.

* cited by examiner

(21) Appl. No.: **10/333,134**

Primary Examiner—Francis J. Jaworski

(22) PCT Filed: **May 16, 2001**

(74) *Attorney, Agent, or Firm*—Oblon, Spivak, McClelland, Maier & Neustadt, P.C.

(86) PCT No.: **PCT/JP01/04064**

§ 371 (c)(1),
(2), (4) Date: **Sep. 29, 2003**

(57) **ABSTRACT**

(87) PCT Pub. No.: **WO02/05716**

PCT Pub. Date: **Jan. 24, 2002**

An ultrasonic angioscope system which uses an imaging technique of sending ultrasonic waves to a portion ahead of a stricture of a blood vessel and visualizing a portion in the forward direction of the angioscope, and which uses a laser breakdown is provided. The ultrasonic angioscope system includes: a laser generating device (11) installed outside the human body; a probe (20) that introduces laser beams (13) emitted from the laser generating device (11) into a blood vessel (1) via an optical fiber (12), is set at the tip of the optical fiber (12), and has a lens (14) and a water tank (15) as a dielectric; ultrasonic-wave generating means that uses a laser breakdown (16) produced in the water tank (15); a plurality of hydrophones (18) that receive reflected waves, of ultrasonic waves emitted by the laser breakdown (16), from a stricture portion (2) of a blood vessel (1), and are disposed at the tip end of the probe (20); and means of forming a stricture-shaped image of the stricture portion (2) based on the signals received from the hydrophones (18) by a synthetic aperture method.

(65) **Prior Publication Data**

US 2004/0102821 A1 May 27, 2004

(30) **Foreign Application Priority Data**

Jul. 18, 2000 (JP) 2000-216862

(51) **Int. Cl.**⁷ **A61B 8/12**

(52) **U.S. Cl.** **600/439; 600/466; 600/471; 606/7; 606/15**

(58) **Field of Search** **600/439, 462-463, 600/466-467, 471; 606/1, 7, 15**

(56) **References Cited**

U.S. PATENT DOCUMENTS

4,504,727 A * 3/1985 Melcher et al. 219/121.62

5 Claims, 5 Drawing Sheets

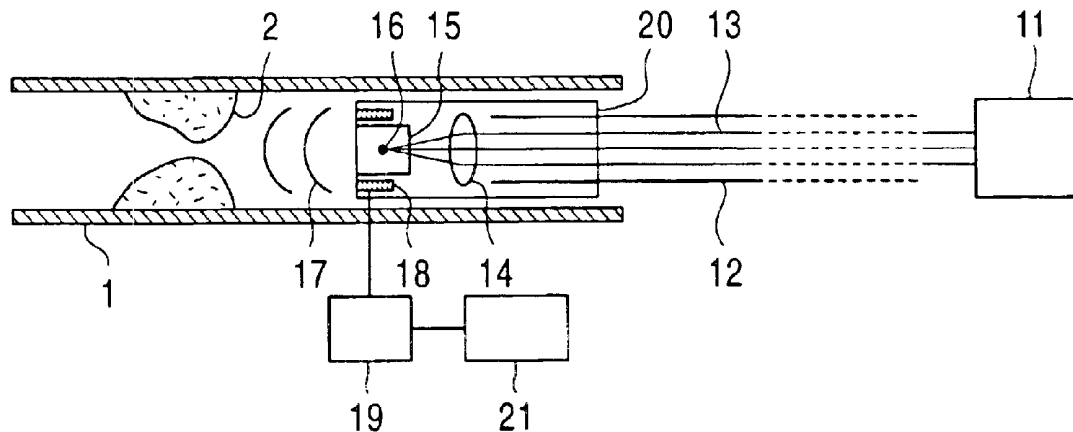

FIG. 1

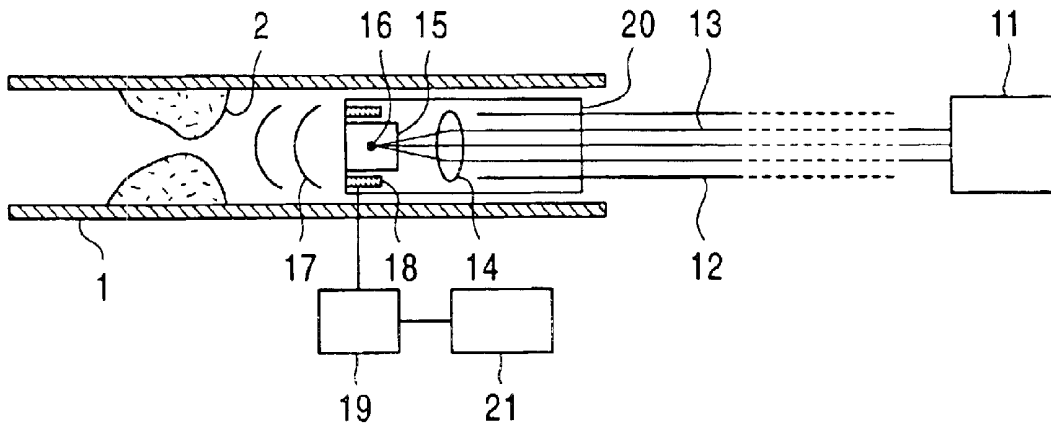

FIG. 2

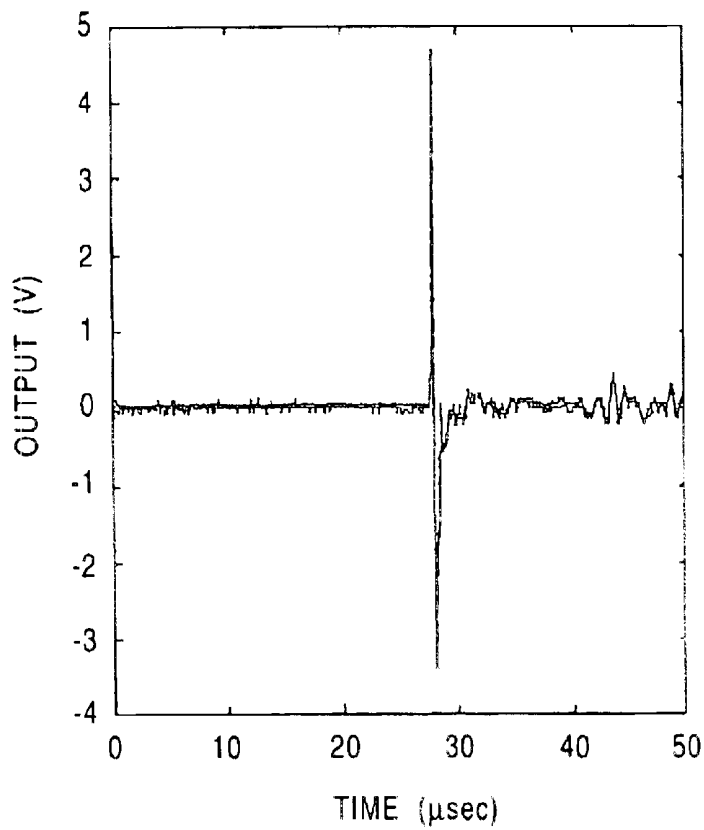

FIG. 3

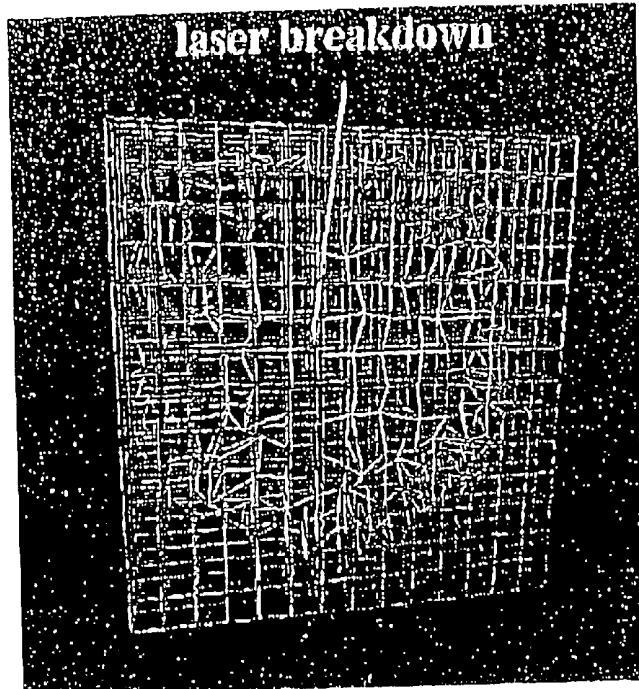

FIG. 4

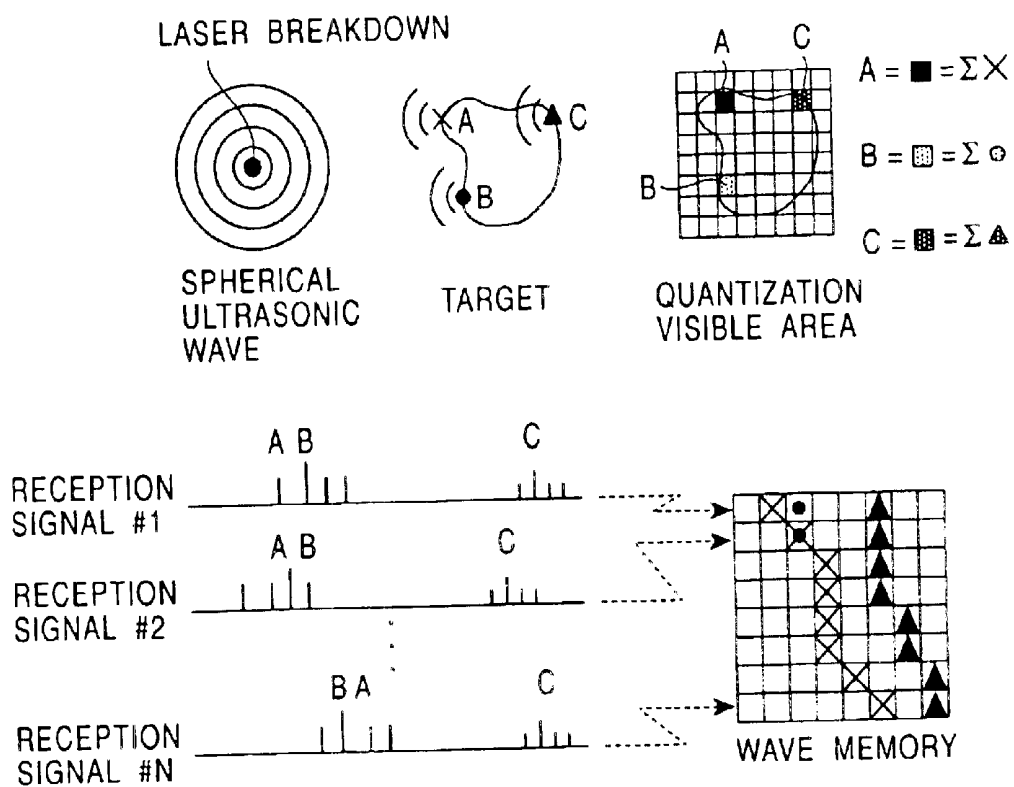

FIG. 5

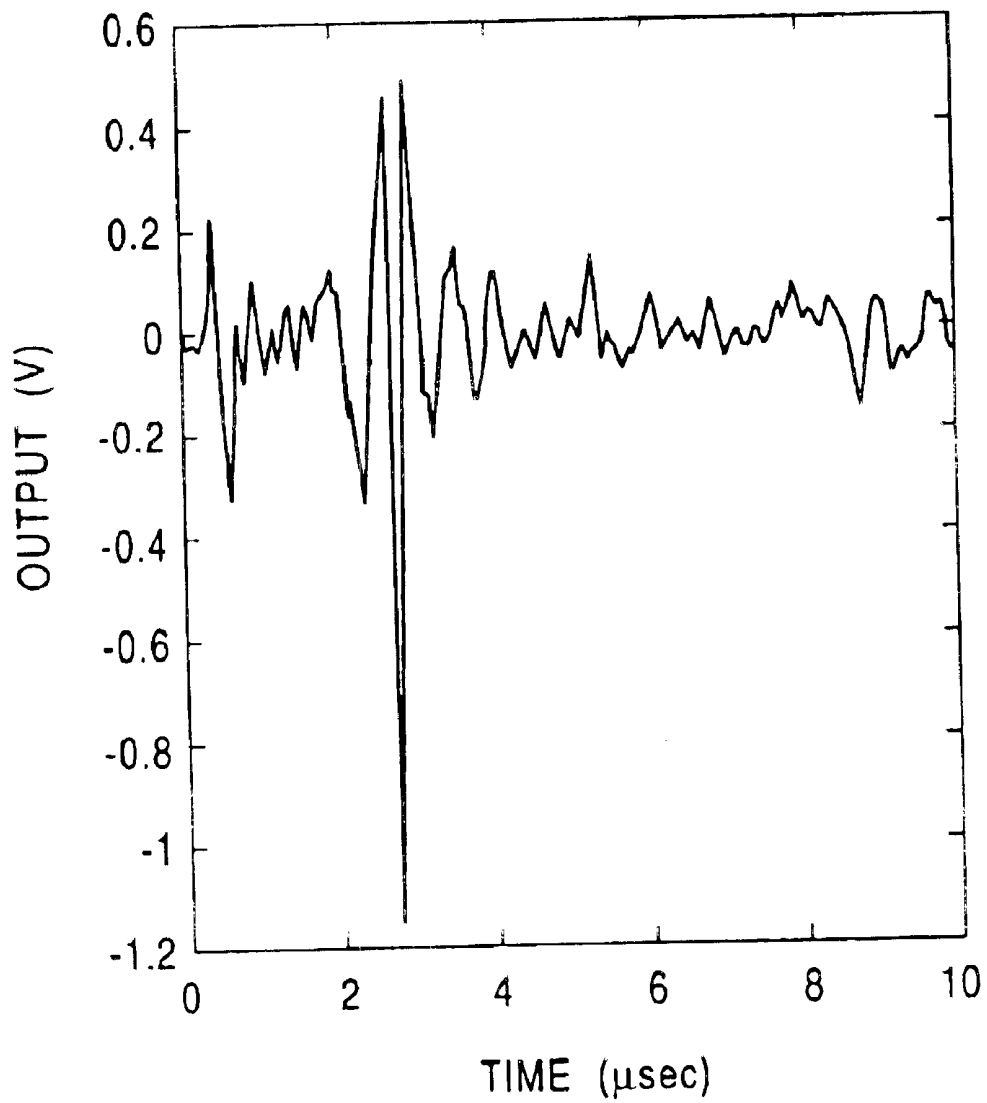
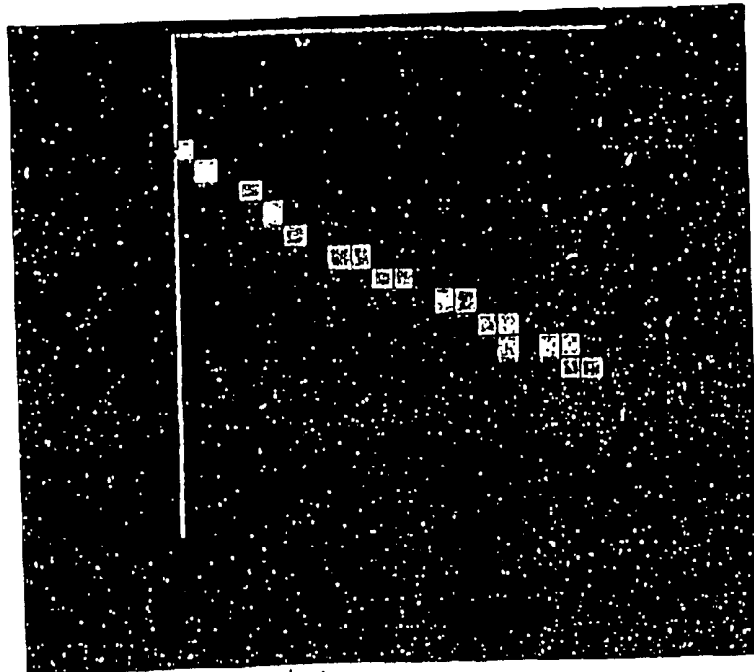

FIG. 6

(a)



(b)

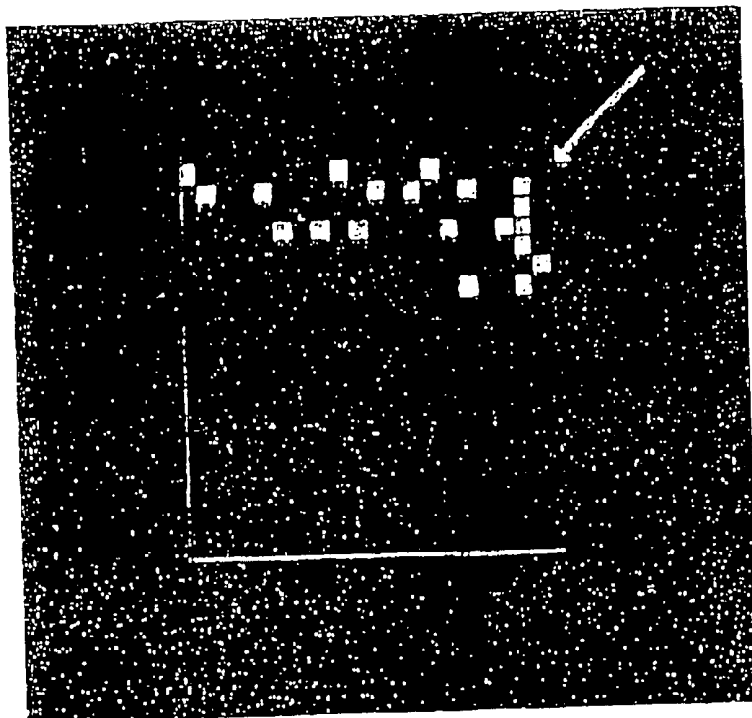

FIG. 7

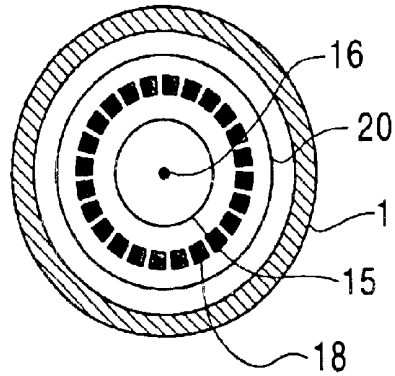
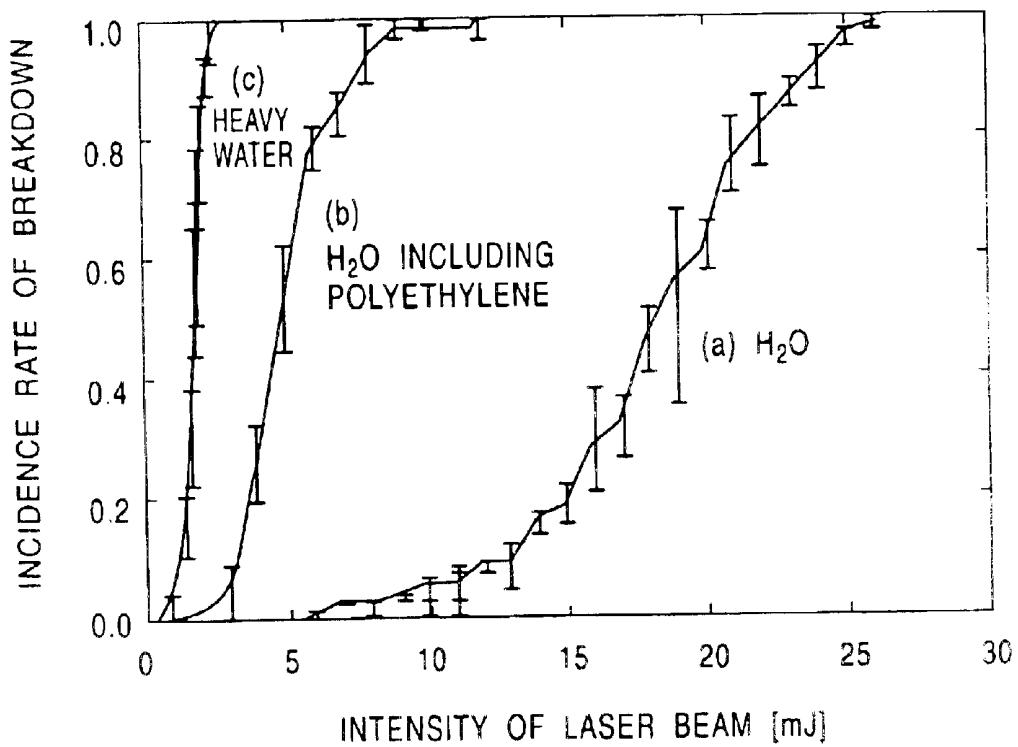

FIG. 8



ULTRASONIC ANGIOSCOPE SYSTEM

TECHNICAL FIELD

The present invention relates to an ultrasonic angioscope system for visualizing a blood vessel in which a stricture portion is caused by using ultrasonic waves generated by the condense of lasers and the occurrence of a laser breakdown.

BACKGROUND ART

Conventionally, technologies in the above-mentioned field are disclosed as follows. That is,

(1) "Handbook of medical ultrasonic devices" edited by Japan Electronic Industry published by CORONA PUBLISHING Co., Ltd. on Jan. 20, 1997, and

(2) Japanese Unexamined Patent Application Publication No. 11-128229.

The conventional ultrasonic angioscope systems obtain the cross section of the blood vessel by scanning beam ultrasonic waves in the circumferential direction.

Hereinbelow, the above conventional ultrasonic angioscope systems are described in detail.

Treatments for a stricture portion of the blood vessel use a method for penetrating the lesion by penetrating a guide wiring in the blood vessel and by using a balloon inserted in the guide wiring. In this case, importantly, the wiring is sufficiently penetrated into the stricture portion. Therefore, a compact system for three-dimensionally visualizing a portion in the forward direction for actual time by ultrasonic waves.

DISCLOSURE OF INVENTION

Currently, the ultrasonic angioscopes transmit ultrasonic waves in the direction with an angle of 90° to a probe axis, and rotates the ultrasonic waves, thereby obtaining a two-dimensional image of the cross-section of the blood vessel. However, the ultrasonic angioscopes takes a long time for obtaining a three-dimensional image and does not obtain ahead information of the stricture portion because there is no method for generating the ultrasonic waves having no directivity.

Further, the conventional ultrasonic angioscopes obtain an image by generating beam ultrasonic waves by using a piezoelectric element and by scanning the beam ultrasonic waves in the circumferential direction. However, the conventional ultrasonic angioscopes have a problem to obtain only two-dimensional information of the cross section of the blood vessel.

To solve the above problems, it is an object of the present invention to provide an ultrasonic angioscope system which uses an imaging technique of sending ultrasonic waves to a portion ahead of a stricture of a blood vessel and visualizing a portion in the forward direction of the angioscope, and which uses a laser breakdown.

To accomplish the above object, according to the present invention,

(1) an ultrasonic angioscope system comprises: a laser generating device installed outside the human body; a probe that introduces laser beams emitted from the laser generating device into a blood vessel via an optical fiber, set at the tip of the optical fiber, having a lens and a dielectric; ultrasonic-wave generating means that uses a laser breakdown generated in the dielectric; a plurality of hydrophones that receive reflected waves, of ultrasonic waves emitted by the laser

breakdown, from a stricture portion of the blood vessel, and are disposed at the tip end of the probe; and means for forming a stricture-shaped image of the stricture portion based on the signals received from the hydrophones by a synthetic aperture method,

(2) in the ultrasonic angioscope system according to (1), the dielectric includes water, deuterium water, and water containing polyethylene,

(3) in the ultrasonic angioscope system according to (2), the water containing polyethylene is obtained by distributing polyethylene particles having a diameter of 50 to 1000 nm in distilled water,

(4) in the ultrasonic angioscope system according to (1), the laser beam is a laser beam of Nd:YAG of 1064 nm, and

(5) in the ultrasonic angioscope system according to (1), 16 to 64 hydrophones among the plurality of hydrophones are concentrically arranged on the probe.

In the ultrasonic angioscope system according to the present invention, the ultrasonic waves with a low directivity are transmitted, and waves reflected from an instrumentation target are received by a plurality of ultrasonic vibrators and are three-dimensionally visualized by a synthetic aperture method.

As transmission ultrasonic waves, the waves with the non-directivity are preferable to visualize a wide range ahead and the ultrasonic waves generated by the piezoelectric element are not used but the ultrasonic waves generated upon the breakdown of the condensed laser are used.

For the purpose of using the ultrasonic vibrator dedicated for reception, the hydrophone made of a polymer-material system having a higher reception sensitivity is utilized as a receiver.

BRIEF DESCRIPTION OF THE DRAWINGS

FIG. 1 is a schematic diagram showing an ultrasonic angioscope system using a laser breakdown according to an embodiment according to the present invention.

FIG. 2 is a diagram showing one example of a reception signal according to the present invention.

FIG. 3 is a diagram showing a status of the propagation of ultrasonic waves using the laser breakdown according to the present invention.

FIG. 4 is a diagram showing an image reconstructing method according to the present invention.

FIG. 5 is a diagram showing a waveform transmitted from an instrumentation target according to the present invention.

FIG. 6 is a diagram showing a result of reconstructing the image using the laser breakdown according to the present invention.

FIG. 7 is a cross-sectional view showing a laser breakdown portion according to the present invention.

FIG. 8 is a diagram showing an incidence rate of a laser induced breakdown according to the present invention.

BEST MODE FOR CARRYING OUT THE INVENTION

Hereinbelow, an embodiment of the present invention will be described in detail with reference to the drawings.

FIG. 1 is a schematic diagram showing an ultrasonic angioscope system using a laser breakdown according to an embodiment of the present invention.

Referring to FIG. 1, reference numeral 1 denotes a blood vessel. Reference numeral 2 denotes a stricture portion of

the blood vessel **1**. Reference numeral **11** denotes a laser generating device installed outside the human body. Reference numeral **12** denotes an optical fiber. Reference numeral **13** denotes laser beams emitted from the laser generating device **11**. The laser beams **13** generated by the laser generating device **11** installed outside the human body pass through the blood vessel **1** by using the optical fiber **12** and are introduced to a desired portion. Reference numeral **14** denotes a lens for condensing the laser beams **13**. Reference numeral **15** denotes a water tank as a dielectric effected by the condensed laser beams. The laser beams **13** introduced in the angioscope are condensed to the small water tank **15** in the angioscope through the lens **14** set therein. The condensed laser beams have a high energy-density and, thus, a breakdown, namely, a laser breakdown **16** is caused. The laser breakdown **1** causes light, heat, and ultrasonic waves. The ultrasonic waves (front spherical waves) from the light, heat, and ultrasonic waves are used for distance instrument. That is, the ultrasonic waves **17** with low directivity are transmitted and waves reflected from the stricture portion **2** in the blood vessel **1** are received by a plurality of high-polymer hydrophones **18** as ultrasonic vibrators. Further, the reflection waves are amplified by an amplifier **19** and, thereafter, the stricture portion **2** is three-dimensionally visualized by a three-dimensional visualizing device **21** [upon checking only the reception signal, by using a digital oscilloscope (DSO)], based on the synthetic aperture method. Reference numeral **20** denotes a probe comprising an optical fiber **12**, including the lens **14** and the water tank **15**.

Specifically speaking, the water tank **15** as a dielectric is filled with distilled water in which polyethylene particles (having a diameter of 200 nm) are distributed. The condensing of Nd:YAG lasers as the laser beams **13** causes the breakdown of a medium near the condensing point and, further, the laser breakdown **16** which generates the light and the ultrasonic waves occurs. Narrowing of a convergent point in this case appears the spherical ultrasonic waves with the non-directivity. The above-mentioned waveform causes little ringing. In the endoscope, the optical fiber **12** introduces to the probe **20**, the laser beams from the laser generating device **11** installed outside the human body and the lens **14** condenses the laser beams to the small water tank **15** in the probe **20**. The condensed lasers have a high energy-density, cause the breakdown, and generate the ultrasonic waves **17** with the non-directivity. A plurality of the hydrophones **18** for reception are installed at the edge of the probe **20** to receive echoes. The three-dimensional image in the forward direction is formed based on the echoes at points by the synthetic aperture method. This effects the diagnosis of the blood vessel and, advantageously, the image is obtained at the position where optical means such as a CCD is not used.

As mentioned above, the lens **14** and the water tank (dielectric) **15** are installed in the probe **20** comprising the optical fiber **12**. The dielectric **15** includes water, deuterium oxide, and water containing polyethylene. A laser condensing spot is within 10 μm , preferably, within 1 μm . As the spot is smaller, the ultrasonic waves have non-directivity. The laser beams **13** are laser beams of Nd:YAG having 1064 nm. Referring to FIG. 7, a plurality of hydrophones **18** for receiving the ultrasonic waves are set at the tip of the probe **20**. Preferably, 16 to 64 hydrophones are arranged concentrically in the probe **20**. The image is formed based on the reception signals from a plurality of hydrophones **18** by using the synthetic aperture method. Preferably, the number of the hydrophones **18** is larger.

Hereinbelow, an example will be described.

The laser beam of Nd:YAG as the laser beam **13** is 1064 nm, has a pulse width of 6 ns, and further has a repetition frequency of 10 Hz and a maximum pulse energy of 180 mJ.

Preferably, the lens **14** has a focusing distance f of 30 mm. The intensity of laser beams is adjusted by using a wavelength of $\lambda/2$ and a polarizer. The polyethylene particles having a diameter of 50 to 1000 nm are distributed in the distilled water in the water tank **15**. In particular, since the water does not absorb light having the wavelength of 1064 nm, the occurrence of heat is suppressed.

The hydrophones **18** use PZT needle hydrophone.

After generating the spherical ultrasonic waves, the generated ultrasonic waves in this case are received by using the PZT needle hydrophones and are amplified. Then, the ultrasonic waves are stored in the digital oscilloscope. FIG. 2 shows an example of the reception signal.

The input laser has a pulse of an exceedingly short width. Therefore, referring to FIG. 2, a waveform indicates an impulse response of an instrumentation system including the PZT needle hydrophones and the amplifier. As will be understood with reference to FIG. 2, the ultrasonic waves caused by the laser breakdown are single sine-waves in which one extension and one contraction are generated for a time of 0.2 μsec . Upon generating the spherical waves, the reflection waves generated in accordance therewith have no directivity. Waves after a high peak are not ringing seen in the ultrasonic waves generated by the ceramic-system vibrator but are waves reflected from the water surface or from the bottom of the water tank. Therefore, large ringing does not exist in the instrumentation system.

Further, the ultrasonic waves generated due to the breakdown are measured at a plurality of points and the wave surface propagated from the points are drawn. FIG. 3 shows an example thereof. FIG. 3 shows an acoustic field after approximately 35 μsec from the occurrence of the laser breakdown.

The laser breakdown is caused at the center point and the top of the lattice indicates an instrumentation point. A distortion of the lattice indicates the size of the reception signal at the instrumentation point. Thus, the waves are isotropically propagated. That is, the occurrence of the spherical waves is confirmed.

Referring to FIG. 2, upon reconstructing the image by using the ultrasonic waves generated due to the laser breakdown, the ringing is extremely small and data from the quantized instrumentation point is assumed as a pulse train. Since the ultrasonic waves have the non-directivity as shown in FIG. 3, it is characterized in that the consideration of weighting is not necessary upon adding the data. Thus, the image reconstruction is performed by using the reconstruction algorithm. FIG. 4 is an explanatory diagram of a method of the image reconstruction.

Herein, a hexangular wrench having a length of several centimeters (cm) is selected as an instrumentation target, is arranged in the water tank, and the reflection waves are measured at a plurality of points by using the PZT needle hydrophones. FIG. 5 shows an example of waveforms after amplification.

Although the reflection signal has a weak intensity as compared with the directly received signal, it has an amplitude sufficient to the three-dimensional instrumentation. Herein, the signal is subjected to the image reconstruction using the simple common-mode addition. FIG. 6 shows a result of reconstructing the instrumentation target.

FIG. 6(a) shows the three-dimensional image of the instrumentation target in the top view, in which a long and thin portion is reconstructed. FIG. 6(b) shows a bending state of a portion shown by an arrow. The use of the spherical waves obtains a high picture-quality even in the simple image reconstructing algorithm.

FIG. 8 is a diagram showing the result of measuring the incidence rate of the breakdown upon changing the laser beam intensity. Referring to FIG. 8, a result (a) of the incident rate of the distilled water (H₂O), a result (b) of the incident rate upon distributing polystyrene (PS) (having a particle diameter of 1 μm) in the water, and a result (c) upon using deuterium oxide (D₂O) are shown. As will be understood, the addition of the polystyrene (having a particle diameter of 1 μm) to the distilled water or the replacement with the deuterium oxide extremely increases the incident rate of the breakdown even by low incident-laser-power. Thus, the ultrasonic waves can safely be generated by decreasing the energy necessary for the laser induced breakdown.

The present invention is not limited to the above-described embodiment and can variously be modified based on the essentials of the present invention, and the various modifications are not excluded from the range of the present invention.

As described in detail, according to the present invention, the following advantages are obtained.

(A) An ultrasonic angioscope system is constructed for sending ultrasonic waves to a portion ahead of a stricture portion of a blood vessel and visualizing a portion in the forward direction of the angioscope without fail.

(B) The ultrasonic waves caused by the laser breakdown are sent and have no directivity, therefore, the wide range in the forward direction is visualized, and this is extremely effective for the diagnosis in the blood vessel.

(C) The ultrasonic waves caused by the laser breakdown are pulse-shaped without ringing and therefore the image having an exceedingly high resolution is reconstructed.

Industrial Applicability

The ultrasonic angioscope system according to the present invention observes the wide range of the stricture portion in the forward direction, which is not optically visualized, and is preferable to the diagnosis and the treatment using the angioscope. Further, expectatively, the ultrasonic angioscope system is used for industrial endoscopes.

What is claimed is:

1. An ultrasonic angioscope system comprising:

- (a) a laser generating device installed outside the human body;
- (b) a probe that introduces laser beams emitted from said laser generating device into a blood vessel via an optical fiber, set at the tip of the optical fiber, having a lens and a dielectric;
- (c) ultrasonic-wave generating means that uses a laser breakdown generated in the dielectric;
- (d) a plurality of hydrophones that receive reflected waves, of ultrasonic waves emitted by the laser breakdown, from a stricture portion of the blood vessel, and are disposed at the tip end of said probe; and
- (e) means for forming a stricture-shaped image of the stricture portion based on the signals received from the hydrophones by a synthetic aperture method.

2. An ultrasonic angioscope system according to claim 1, wherein said dielectric includes water, deuterium water, and water containing polyethylene.

3. An ultrasonic angioscope system according to claim 2, wherein said water containing polyethylene is obtained by distributing polyethylene particles having a diameter of 50 to 1000 nm in distilled water.

4. An ultrasonic angioscope system according to claim 1, wherein said laser beam is a laser beam of Nd:YAG of 1064 nm.

5. An ultrasonic angioscope system according to claim 1, wherein 16 to 64 hydrophones among said plurality of hydrophones are concentrically arranged on said probe.

* * * * *

专利名称(译)	超声波血管内窥镜系统		
公开(公告)号	US6858009	公开(公告)日	2005-02-22
申请号	US10/333134	申请日	2001-05-16
[标]申请(专利权)人(译)	川田聪 杉浦TADAO OHSHIRO OSAMU 茅原国广		
申请(专利权)人(译)	川田聪 杉浦TADAO OHSHIRO OSAMU 茅原国广		
当前申请(专利权)人(译)	日本科学技术振兴事业团		
[标]发明人	KAWATA SATOSHI SUGIURA TADAO OHSHIRO OSAMU CHIHARA KUNIHIO		
发明人	KAWATA, SATOSHI SUGIURA, TADAO OHSHIRO, OSAMU CHIHARA, KUNIHIO		
IPC分类号	A61B5/026 A61B8/06 A61B8/12		
CPC分类号	A61B5/0261 A61B8/12 A61B8/06 A61B5/0263		
优先权	2000216862 2000-07-18 JP		
其他公开文献	US20040102821A1		
外部链接	Espacenet USPTO		

摘要(译)

本发明提供一种超声波血管造影系统，该系统使用将超声波发送到血管狭窄之前的部分并使血管镜的前方部分可视化并使用激光击穿的成像技术。超声波血管内窥镜系统包括：安装在人体外部的激光发生装置（11）；将从激光产生装置（11）发射的激光束（13）经由光纤（12）引入血管（1）的探针（20）设置在光纤（12）的尖端，并且具有透镜（14）和水槽（15）作为电介质；超声波发生装置，使用在水箱（15）中产生的激光击穿（16）；多个水听器（18），其接收来自激光击穿（16）的超声波的反射波，来自血管（1）的狭窄部分（2），并设置在探头的尖端（20）；和基于通过合成孔径方法从水听器（18）接收的信号形成狭窄部分（2）的狭窄形状图像的装置。

