



(19) **United States**

(12) **Patent Application Publication**
Cho

(10) **Pub. No.: US 2011/0066033 A1**

(43) **Pub. Date: Mar. 17, 2011**

(54) **PROBE OF ULTRASONIC DIAGNOSTIC APPARATUS AND METHOD OF SUPPRESSING VIBRATION THEREOF**

(52) **U.S. Cl. 600/459**

(57) **ABSTRACT**

(76) **Inventor: Joo Yeon Cho, Chuncheon-si (KR)**

A probe of an ultrasonic diagnostic apparatus and a method of suppressing vibration thereof are disclosed. The probe includes a transducer moving along a preset locus; a drive unit driving the transducer, a detector sensing real-time vibration of the transducer during movement of the transducer, and a controller controlling operation of the drive unit depending on a sensed degree of vibration to suppress the real-time vibration of the transducer. Factors related to the drive unit and generating vibration of the transducer can be suppressed by changing a drive force transmitted to the transducer depending on a detected degree of real-time vibration of the transducer to suppress vibration of the transducer, thereby improving accuracy in ultrasonic diagnosis and providing a more accurate ultrasound image.

(21) **Appl. No.: 12/878,875**

(22) **Filed: Sep. 9, 2010**

(30) **Foreign Application Priority Data**

Sep. 11, 2009 (KR) 10-2009-0085865

Publication Classification

(51) **Int. Cl. A61B 8/14 (2006.01)**

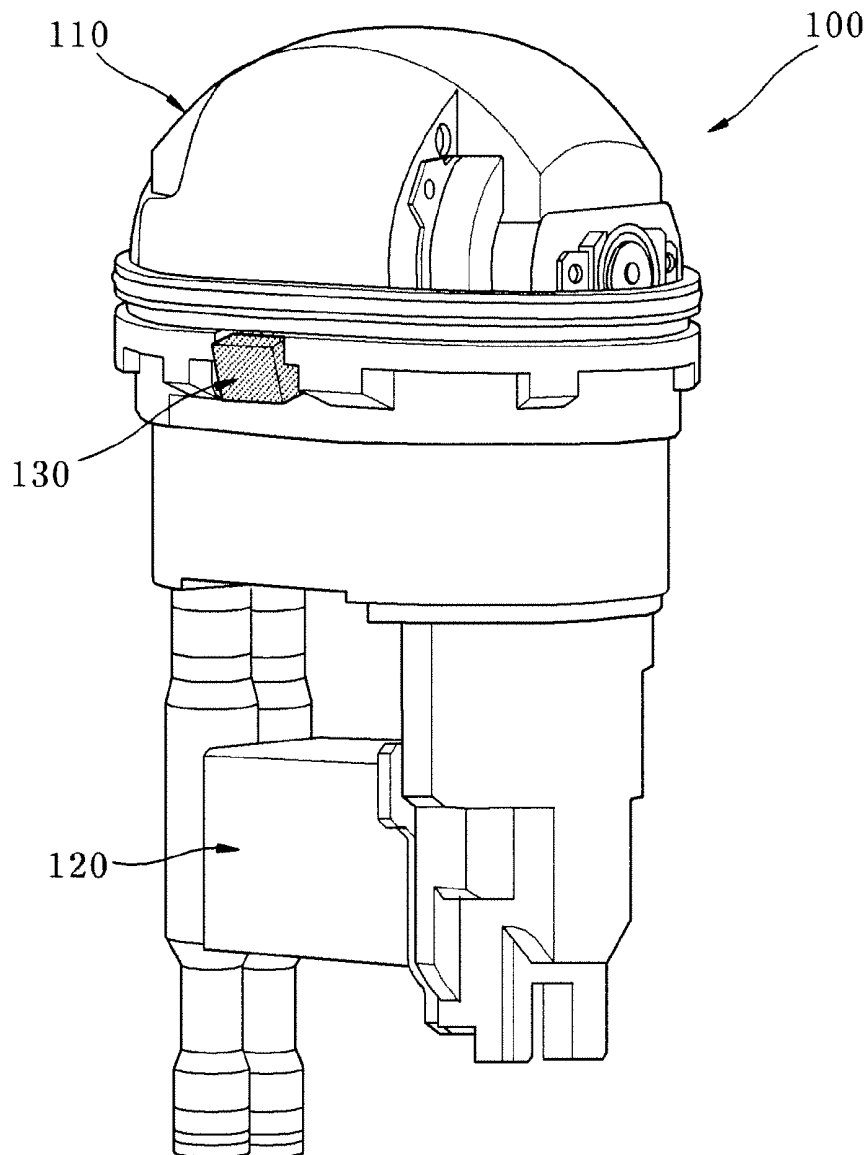

Fig. 1

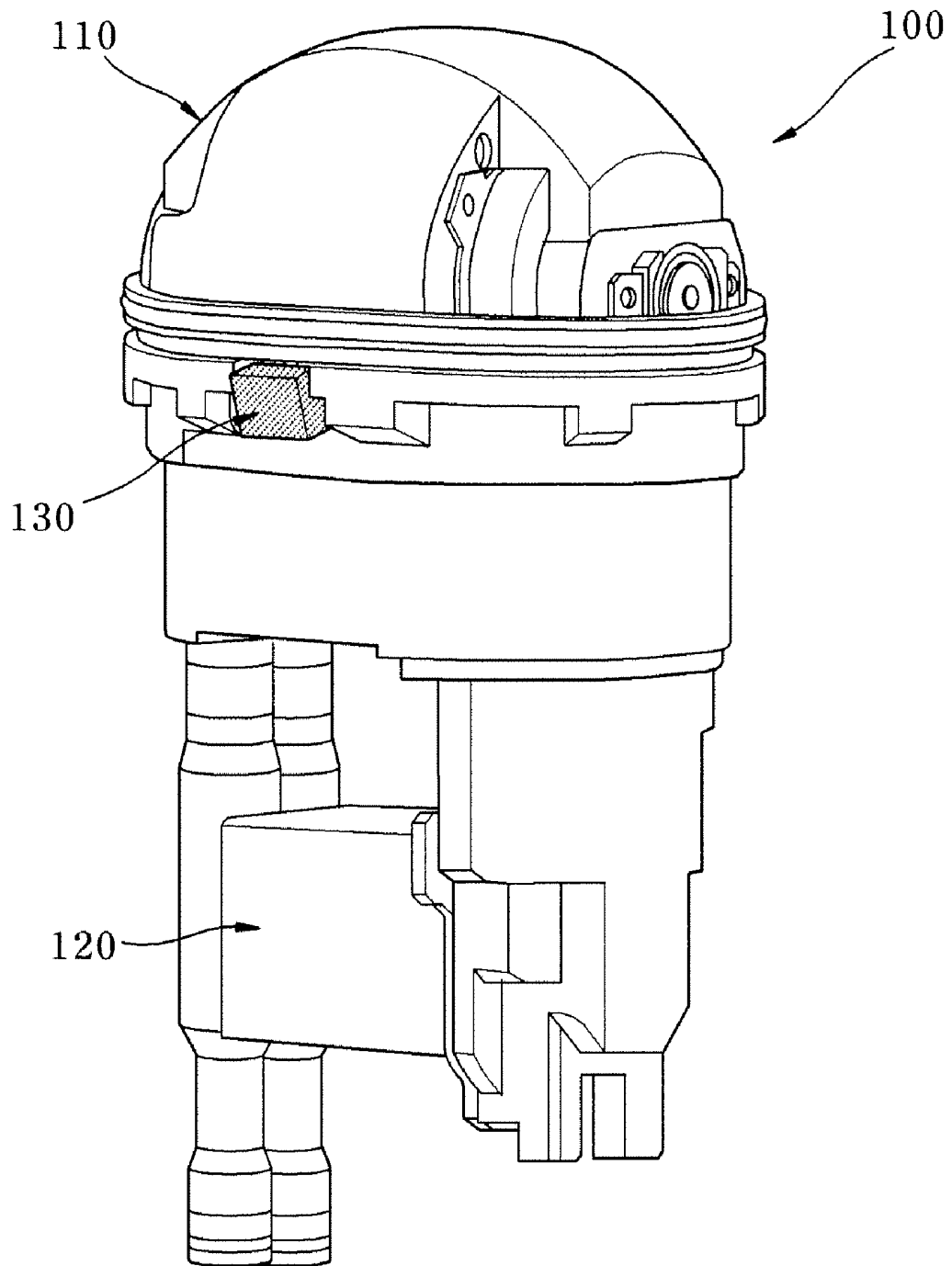

Fig. 2

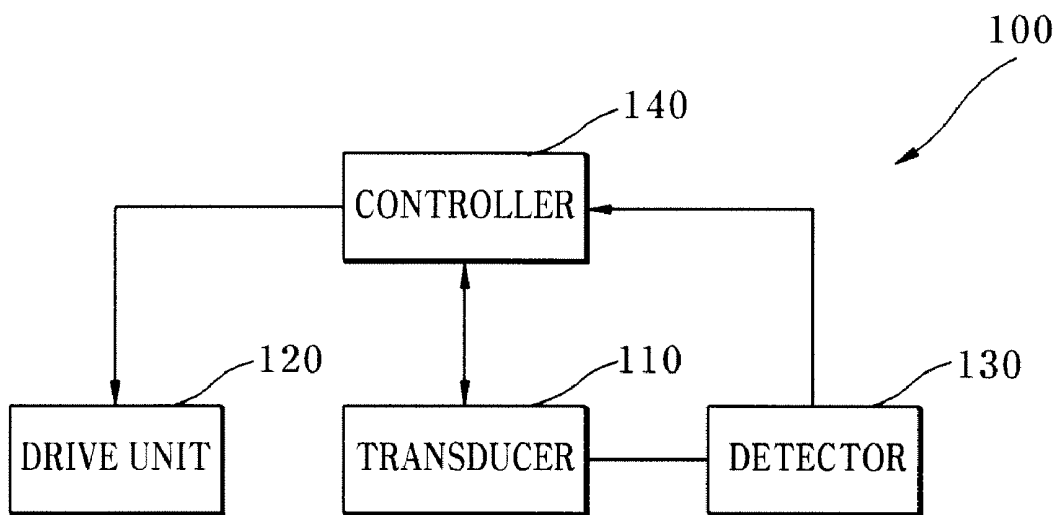

Fig. 3

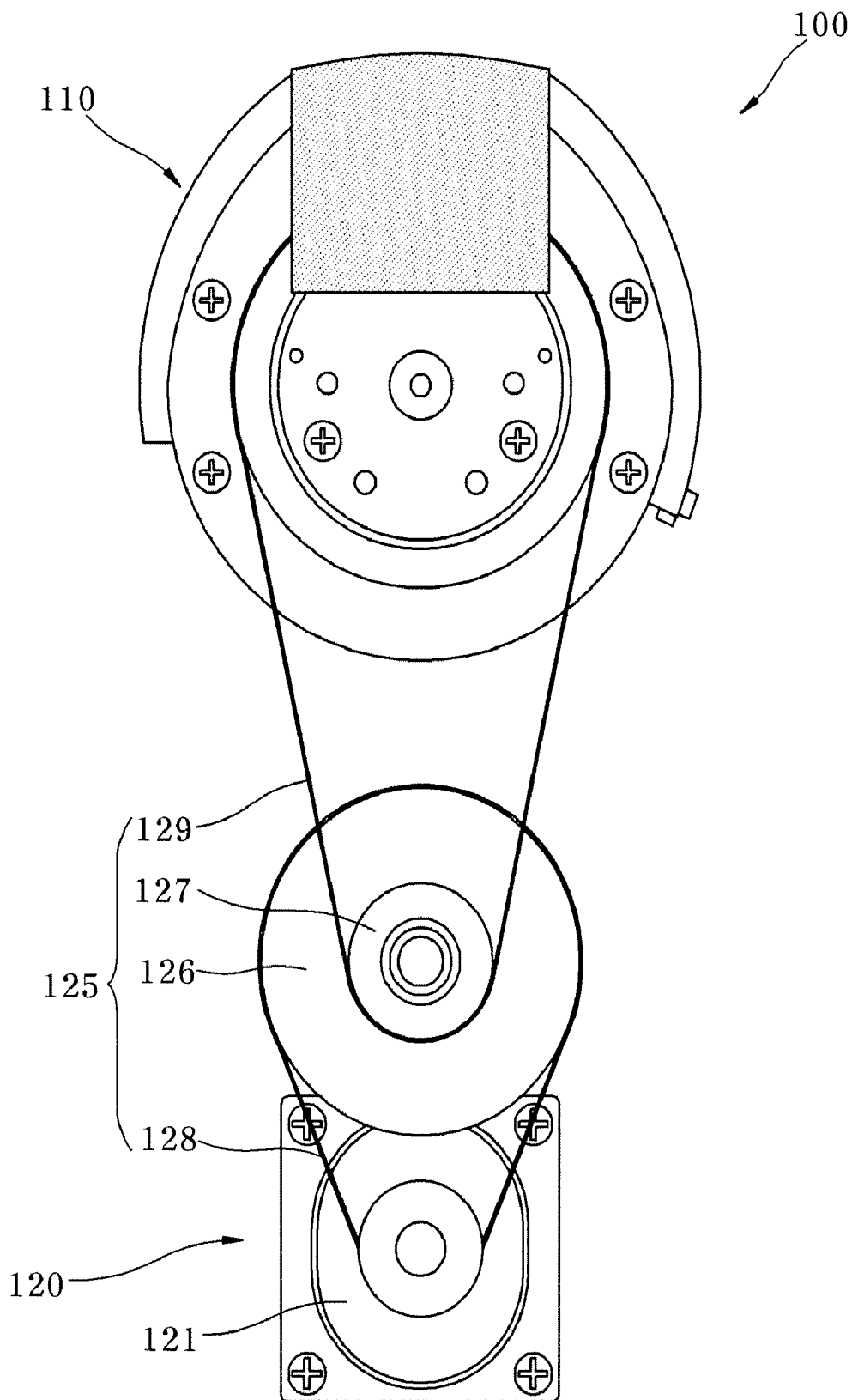

Fig. 4

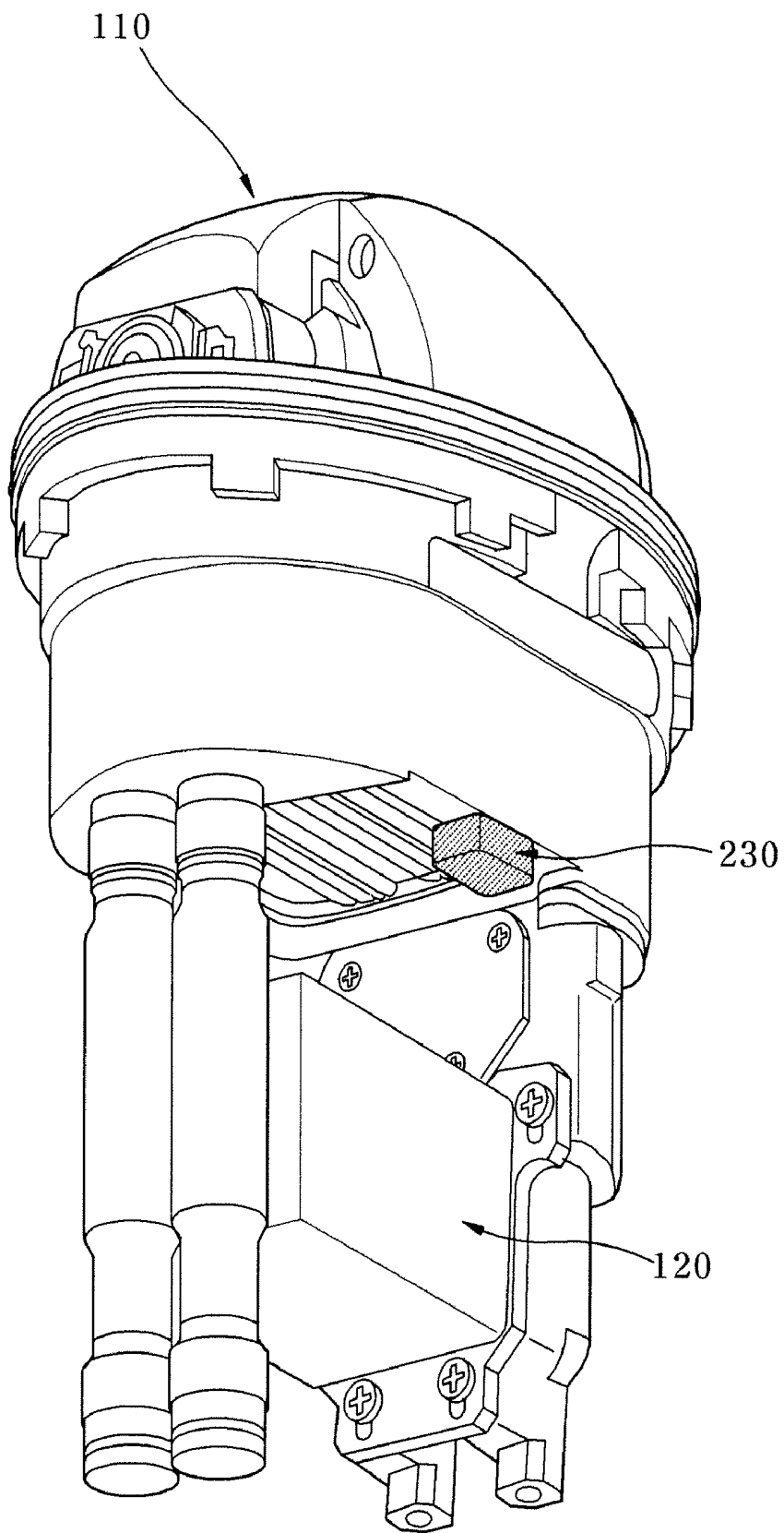
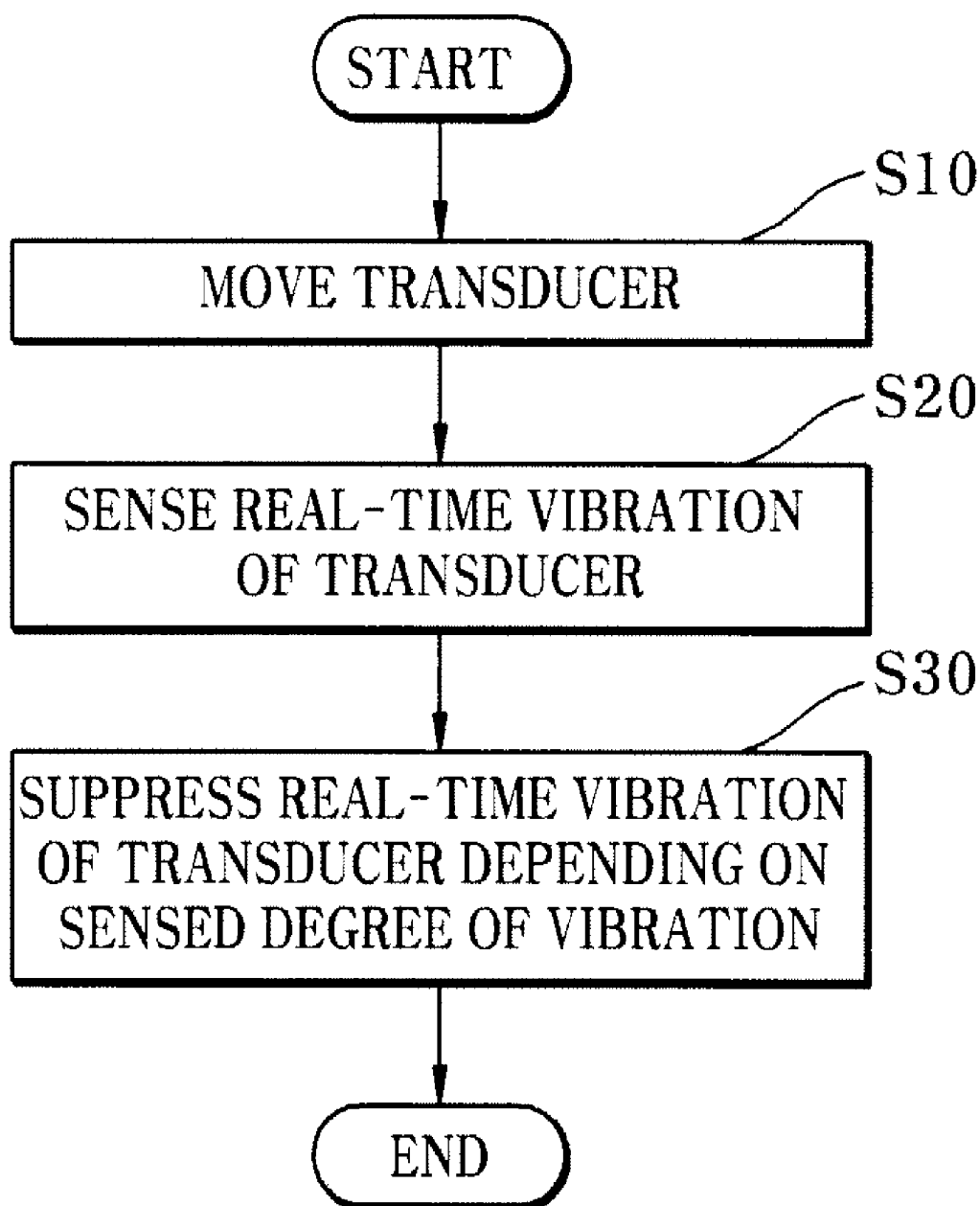

Fig. 5

**PROBE OF ULTRASONIC DIAGNOSTIC
APPARATUS AND METHOD OF
SUPPRESSING VIBRATION THEREOF**

**CROSS REFERENCE TO RELATED
APPLICATIONS**

[0001] This application claims the benefit of Korean Patent Application No. 10-2009-0085865, filed Sep. 11, 2009, the entire contents of which are incorporated herein by reference.

BACKGROUND OF THE INVENTION

[0002] 1. Field of the Invention

[0003] The present invention relates to a probe of an ultrasonic diagnostic apparatus and, more particularly, to a probe of an ultrasonic diagnostic apparatus that generates internal images of a patient body using ultrasound waves, and a method of suppressing vibration thereof.

[0004] 2. Description of the Related Art

[0005] Generally, an ultrasonic diagnostic apparatus refers to a non-invasive apparatus that irradiates an ultrasound signal from a surface of a patient body towards a target internal organ beneath the body surface and obtains an image of a monolayer or blood flow in soft tissue from information in the reflected ultrasound signal (ultrasound echo-signal). The ultrasonic diagnostic apparatus has been widely used for diagnosis of the heart, the abdomen, the urinary organs, and in obstetrics and gynecology due to various merits thereof such as small size, low price, real-time image display, and high stability through elimination of radiation exposure, as compared with other image diagnostic systems, such as X-ray diagnostic systems, computerized tomography scanners (CT scanners), magnetic resonance imagers (MRIs), nuclear medicine diagnostic apparatuses, and the like.

[0006] The ultrasonic diagnostic apparatus includes a cart-shaped main body for receiving main components thereof, a probe for transmitting and receiving ultrasound signals, a control panel having various switches and keys for inputting commands for manipulation of the apparatus, and a display unit for displaying an image of an ultrasonic diagnosis result.

[0007] The probe includes a transducer that converts electrical signals into sound signals or vice versa. The transducer includes an ultrasound wave vibrator assembly composed of a set of ultrasound wave vibrators, which send ultrasound signals to a target to obtain an image of the target using the signals reflected from the target.

[0008] In recent years, with development of image processing techniques, an ultrasonic diagnostic apparatus has been developed to display a three-dimensional ultrasound image. In such an ultrasonic diagnostic apparatus, the probe can obtain an image of a three-dimensional region using a transducer which transmits and receives ultrasound signals while moving along a preset locus.

[0009] In such a probe, since it is necessary for the transducer to move right and left to obtain a three-dimensional image, the transducer suffers vibration caused by various factors. When vibration is generated in the transducer, an accurate ultrasound image of a target cannot be obtained. Therefore, there is a need to provide a probe apparatus that overcomes such a problem.

[0010] It should be noted that the above description is provided for understanding of the background of the invention and is not a description of a conventional technique well-known in the art.

SUMMARY OF THE INVENTION

[0011] The present invention is conceived to solve the problems of the related art as described above, and an aspect of the invention is to provide a probe of an ultrasonic diagnostic apparatus that can suppress vibration of the probe, and a method of suppressing vibration thereof.

[0012] In accordance with one aspect on the present invention, a probe of an ultrasonic diagnostic apparatus includes: a transducer; a drive unit configured to move the transducer along a preset locus; a detector configured to sense real-time vibration of the transducer during movement of the transducer; and a controller configured to control the drive unit responsive to the detector to suppress the real-time vibration of the transducer.

[0013] The detector may include a vibration sensor.

[0014] In accordance with another aspect of the invention, a probe of an ultrasonic diagnostic apparatus includes: a transducer moving along a preset locus; a drive unit driving the transducer; a detector sensing real-time vibration of the transducer during movement of the transducer; and a controller controlling operation of the drive unit depending on a sensed degree of vibration to suppress the real-time vibration of the transducer.

[0015] The detector may be provided to the transducer.

[0016] In accordance with another aspect of the invention, a method of suppressing vibration of a probe of an ultrasonic diagnostic apparatus includes: moving a transducer along a preset locus; sensing real-time vibration of the transducer; and suppressing the real-time vibration of the transducer based on the sensed real-time vibration.

[0017] Sensing real-time vibration of the transducer may include sensing the real-time vibration of the transducer using a detector provided to the transducer.

[0018] Suppressing the real-time vibration may include suppressing the real-time vibration of the transducer by controlling operation of a drive unit configured to move the transducer.

[0019] The sensing real-time vibration of the moving transducer may include sensing the real-time vibration of the transducer using a detector provided to the transducer.

[0020] The suppressing the real-time vibration may include suppressing the real-time vibration of the transducer by controlling operation of the drive unit depending on the sensed degree of vibration.

[0021] According to embodiments, factors related to the drive unit and generating vibration of the transducer can be suppressed by changing a drive force transmitted to the transducer depending on a detected degree of real-time vibration of the transducer to suppress vibration of the transducer, thereby improving accuracy in ultrasonic diagnosis and providing a more accurate ultrasound image.

BRIEF DESCRIPTION OF THE DRAWINGS

[0022] The above and other aspects, features and advantages of the invention will become apparent from the following description in conjunction with the accompanying drawings, in which:

[0023] FIG. 1 is a perspective view of a probe of an ultrasonic diagnostic apparatus in accordance with one embodiment of the present invention;

[0024] FIG. 2 is a block diagram of the probe in accordance with the embodiment of the present invention;

[0025] FIG. 3 is a cross-sectional view of the probe in accordance with the embodiment of the present invention;

[0026] FIG. 4 is a perspective view of a probe of an ultrasonic diagnostic apparatus in accordance with another embodiment of the present invention; and

[0027] FIG. 5 is a flowchart of a method of suppressing vibration of a probe of an ultrasonic diagnostic apparatus in accordance with one embodiment of the present invention.

DETAILED DESCRIPTION OF THE EMBODIMENT

[0028] Exemplary embodiments of the invention will now be described in detail with reference to the accompanying drawings. It should be noted that the drawings are not to precise scale and may be exaggerated in thickness of lines or size of components for descriptive convenience and clarity only. Furthermore, terms used herein are defined by taking functions of the invention into account and can be changed according to the custom or intention of users or operators. Therefore, definition of the terms should be made according to overall disclosures set forth herein.

[0029] FIG. 1 is a perspective view of a probe of an ultrasonic diagnostic apparatus in accordance with one embodiment of the present invention, FIG. 2 is a block diagram of the probe in accordance with the embodiment of the present invention, FIG. 3 is a cross-sectional view of the probe in accordance with the embodiment of the present invention, and FIG. 4 is a perspective view of a probe of an ultrasonic diagnostic apparatus in accordance with another embodiment of the present invention.

[0030] Referring to FIGS. 1 to 3, a probe 100 of an ultrasonic diagnostic apparatus according to one embodiment includes a transducer 110, a drive unit 120, a detector 130, and a controller 140.

[0031] The transducer 110 moves along a preset locus. The transducer 110 is rotatably disposed inside the probe 100 and transmits an ultrasound signal to a target and receives an ultrasound echo-signal reflected therefrom to realize a three-dimensional image of the target while moving along the preset locus, for example, to be rotated along a predetermined rotational radius.

[0032] The transducer 110 includes a piezoelectric layer (not shown) in which a piezoelectric material converts electrical signals into sound signals or vice versa while vibrating, a sound matching layer (not shown) reducing a difference in sound impedance between the piezoelectric layer and a target to allow as much of the ultrasound signals generated from the piezoelectric layer as possible to be transferred to the target, a lens layer (not shown) focusing the ultrasound signals, which travel in front of the piezoelectric layer, onto a predetermined point, and a backing layer (not shown) blocking the ultrasound signals from traveling in the rearward direction of the piezoelectric layer to prevent image distortion.

[0033] The drive unit 120 operates the transducer 110. Referring to FIG. 3, the drive unit 120 includes a power generator 121 which generates a drive force, and a power transmission unit 125 which transmits the drive force from the power generator 121 to the transducer 110.

[0034] The power transmission unit 125 includes a driving pulley 126 and a driven pulley 127. The driving pulley 126 receives the drive force from the power generator 121 through a driving belt 128 that connects the power generator 121 to the driving pulley 126, and the driven pulley 127 is associated with the driving pulley 126 to transmit the drive force to a driven belt 129 that connects the transducer 110 to the driven pulley 127. When receiving the driving force through the driven pulley 127, the driving belt 129 transmits the driving force to the transducer 110 to allow the transducer 110 to move along a preset locus.

[0035] Referring to FIGS. 1 and 2, the detector 130 is provided to the transducer 110 or the drive unit 120 and senses real-time vibration of the transducer 110 during movement of the transducer 110. Although, in this embodiment, the detector 130 is provided to the transducer 110, the invention is not limited thereto. Alternatively, the detector 230 may be provided to the drive unit 120 (see FIG. 4) or any other proper position so long as it can sense the vibration of the transducer.

[0036] The detector 130 includes a vibration sensor for sensing vibration generated in the probe 100 of the ultrasonic diagnostic apparatus. The detector 130 senses the real-time vibration of the transducer 110 and transmits a detected degree of vibration to the controller 140.

[0037] The controller 140 controls operation of the transducer 110 and the drive unit 120. In this embodiment, the controller 140 controls not only fundamental operation of the transducer 110 and the drive unit 120, but also operation of the drive unit 120 in association with the detected degree of vibration to suppress the real-time vibration of the transducer 110. This will be described in detail below.

[0038] FIG. 5 is a flowchart of a method of suppressing vibration of a probe of an ultrasonic diagnostic apparatus in accordance with one embodiment of the invention.

[0039] Referring to FIGS. 2 and 5, the method of suppressing vibration of the probe according to this embodiment will be described.

[0040] When the probe 100 starts to operate, the power generator 121 of the drive unit 120 is operated to generate a drive force. The drive force generated by the power generator 121 is transmitted to the transducer 110 through the power transmission unit 125, so that the transducer 110 receiving the drive force moves along a preset locus, in S10.

[0041] While moving along the preset locus, the transducer 110 can undergo vibration relating to a variety of factors. For example, the transducer 110 can be vibrated by vibration transmitted from the drive unit 120, impact by inertial movement at a point where the transducer 110 changes a moving direction, or other factors such as use conditions, use patterns, or the like.

[0042] In this embodiment, the vibration of the transducer 110 is sensed by the detector 130. The detector 130 senses real-time vibration of the transducer 110 and transmits a sensed degree of vibration of the transducer 110 to the controller 140 in real time in S20.

[0043] When receiving the sensed degree of vibration of the transducer 110 in real time from the detector 130, the controller suppresses the real-time vibration of the transducer 110 depending on the sensed degree of vibration in S30. In this embodiment, the controller 140 controls operation of the drive unit 120 to change the drive force depending on the sensed degree of vibration, thereby suppressing the real-time vibration of the transducer 110.

[0044] For example, the controller **140** compares the degree of vibration, transmitted in real time from the detector **130**, with a preset reference degree of vibration, and controls the operation of the drive unit **120** to lower the drive force transmitted from the drive unit **120** to the transducer **110**, if the degree of vibration transmitted from the detector **130** exceeds the preset reference degree of vibration.

[0045] The controller **140** controls the operation of the drive unit **120** to change the drive force transmitted to the transducer **110** depending on the degree of vibration of the transducer **110** which is sensed in real time, thereby suppressing the vibration of the transducer **110** caused by various factors, such as vibration transmitted from the drive unit **120**, impact by movement of the transducer **110** at a point where the transducer **110** changes the moving direction, and the like.

[0046] Such controlling the operation of the drive unit **120** is performed to reduce the real-time vibration of the transducer **110** as sensed by the detector **130** to the preset reference degree or less.

[0047] In the probe **100** of the ultrasonic diagnostic apparatus according to this embodiment, factors related to the drive unit **120** and generating vibration of the transducer **110** can be suppressed by changing a drive force transmitted to the transducer **110** depending on a detected degree of real-time vibration of the transducer **110** to suppress vibration of the transducer **110**, thereby improving accuracy in ultrasonic diagnosis and providing a more accurate ultrasound image.

[0048] Although some embodiments have been provided to illustrate the invention in conjunction with the drawings, it will be apparent to those skilled in the art that the embodiments are given by way of illustration only, and that various modifications and equivalent embodiments can be made without departing from the spirit and scope of the invention.

Further, the description of the probe as provided herein is only one example of the invention, and the invention can be applied not only to a three-dimensional probe but also to a two-dimensional probe. The scope of the invention should be limited only by the accompanying claims.

What is claimed is:

1. A probe of an ultrasonic diagnostic apparatus comprising:

- a transducer;
- a drive unit configured to move the transducer along a preset locus;
- a detector configured to sense real-time vibration of the transducer during movement of the transducer; and
- a controller configured to control the drive unit responsive to the detector to suppress the real-time vibration of the transducer.

2. The probe according to claim 1, wherein the detector comprises a vibration sensor.

3. A method of suppressing vibration of a probe of an ultrasonic diagnostic apparatus, comprising:
moving a transducer along a preset locus;
sensing real-time vibration of the transducer; and
suppressing the real-time vibration of the transducer based on the sensed real-time vibration.

4. The method according to claim 3, wherein sensing real-time vibration of the transducer comprises sensing the real-time vibration of the transducer using a detector provided to the transducer.

5. The method according to claim 3, wherein suppressing the real-time vibration comprises suppressing the real-time vibration of the transducer by controlling operation of a drive unit configured to move the transducer.

* * * * *

专利名称(译)	超声波诊断装置及其振动抑制方法的探讨		
公开(公告)号	US20110066033A1	公开(公告)日	2011-03-17
申请号	US12/878875	申请日	2010-09-09
[标]申请(专利权)人(译)	CHO JOO YEON		
申请(专利权)人(译)	CHO JOO YEON		
当前申请(专利权)人(译)	CHO JOO YEON		
[标]发明人	CHO JOO YEON		
发明人	CHO, JOO YEON		
IPC分类号	A61B8/14		
CPC分类号	A61B8/4444 A61B8/5276 A61B8/4455		
优先权	1020090085865 2009-09-11 KR		
外部链接	Espacenet	USPTO	

摘要(译)

公开了一种超声诊断设备的探头和抑制其振动的方法。探头包括沿预设轨迹移动的换能器;驱动换能器的驱动单元,检测换能器移动期间换能器的实时振动的检测器,以及控制器根据检测到的振动程度控制驱动单元的操作以抑制换能器的实时振动。通过根据检测到的换能器的实时振动的程度改变传输到换能器的驱动力,可以抑制与驱动单元相关的因素和产生振动的换能器,从而抑制换能器的振动,从而提高超声波诊断的准确性并提供更准确的超声图像。

