



US 20060241481A1

(19) **United States**

(12) **Patent Application Publication**
Itoi

(10) **Pub. No.: US 2006/0241481 A1**

(43) **Pub. Date: Oct. 26, 2006**

(54) **ULTRASONIC ENDOSCOPE**

(52) **U.S. Cl. 600/466**

(75) **Inventor: Hiromu Itoi, Saitama-shi (JP)**

(57) **ABSTRACT**

Correspondence Address:
BIRCH STEWART KOLASCH & BIRCH
PO BOX 747
FALLS CHURCH, VA 22040-0747 (US)

(73) **Assignee: Fujinon Corporation**

A distal hard part in an insertion portion is provided with an ultrasonic transducer in which a large number of ultrasonic vibrators are arranged in the circumferential direction. The ultrasonic transducer is shaped like a cylinder. Each member that constitutes an endoscopic observation section is passed through this tunnel-like passage. Each ultrasonic vibrator is provided with a single common electrode and individual electrodes the number of which corresponds to the number of the ultrasonic vibrators. Flexible boards and are provided on the proximal and distal end sides of the ultrasonic transducer. Wires are connected to these flexible boards. The wires from the flexible board are extended without changes, whereas the wires from the flexible board are reversely turned from the distal end side, are then passed through the tunnel-like passage, and are extended in the direction of an angle part.

(21) **Appl. No.: 11/392,707**

(22) **Filed: Mar. 30, 2006**

(30) **Foreign Application Priority Data**

Mar. 31, 2005 (JP) P.2005-100552

Publication Classification

(51) **Int. Cl.**
A61B 8/14 (2006.01)

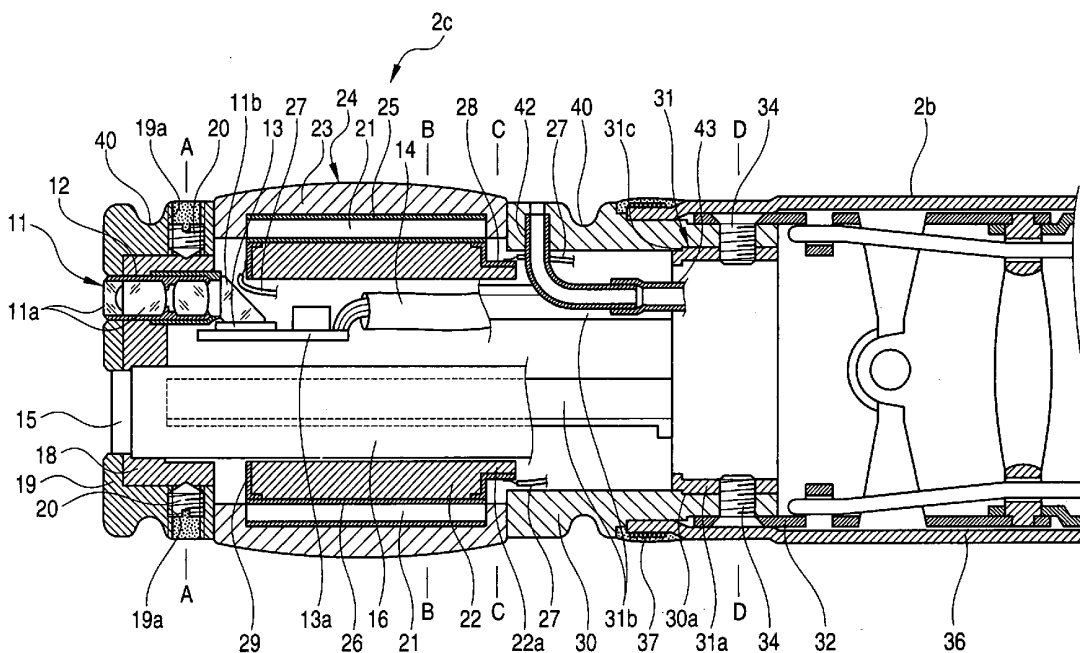

FIG. 1

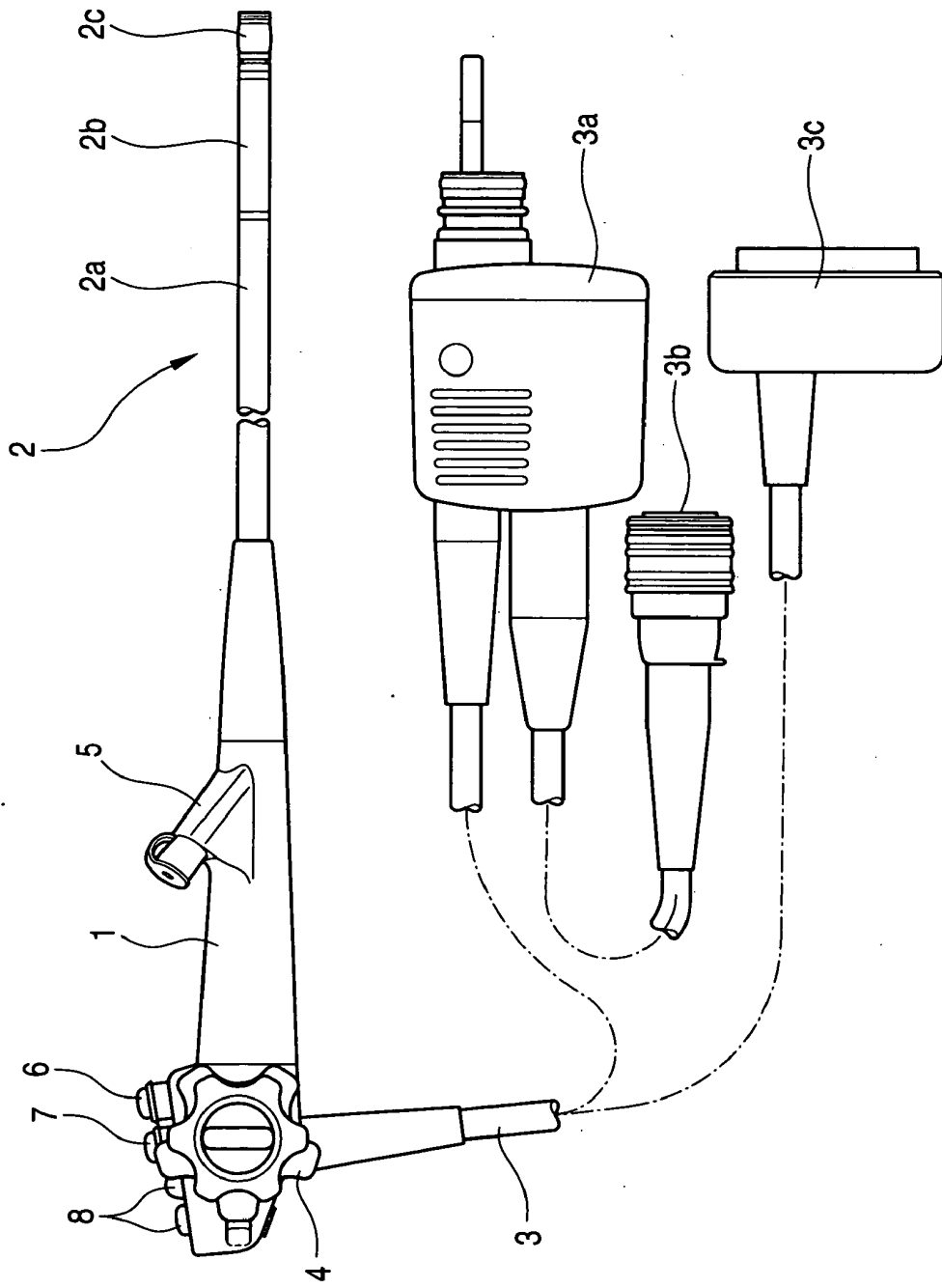

FIG. 2

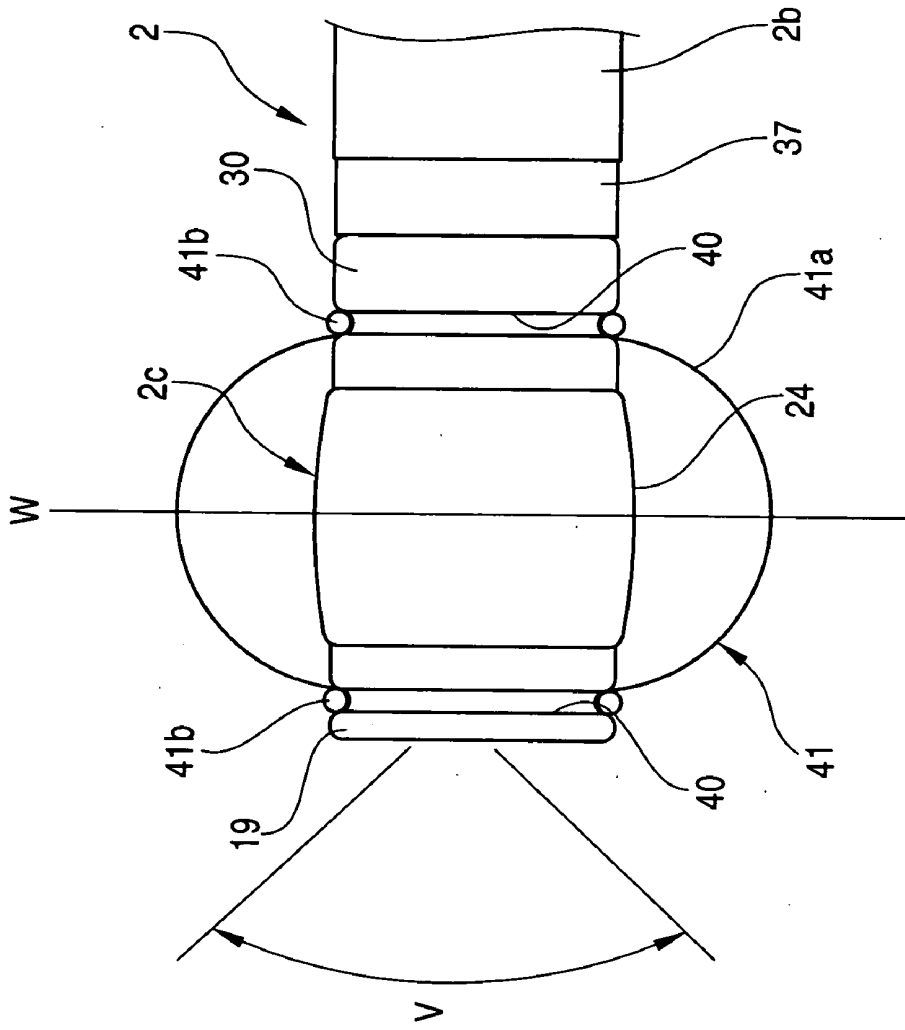

FIG. 3

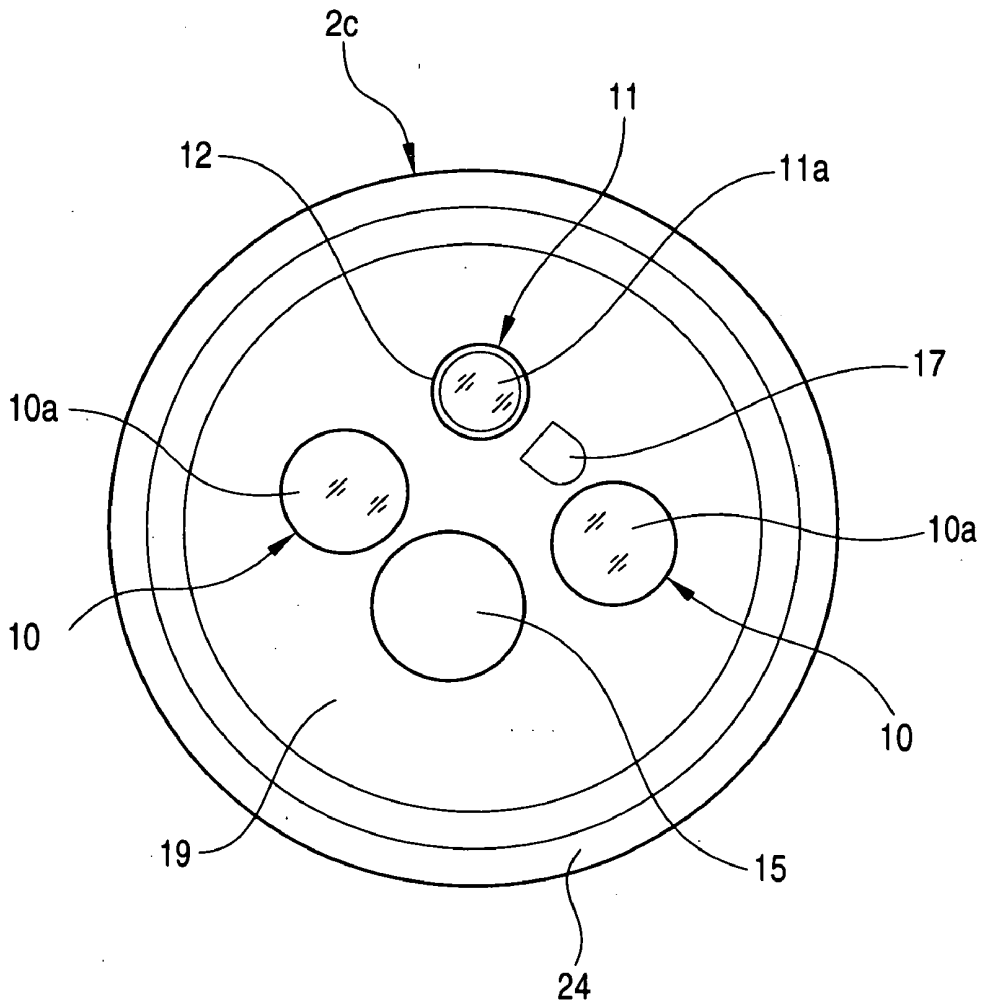

FIG. 4

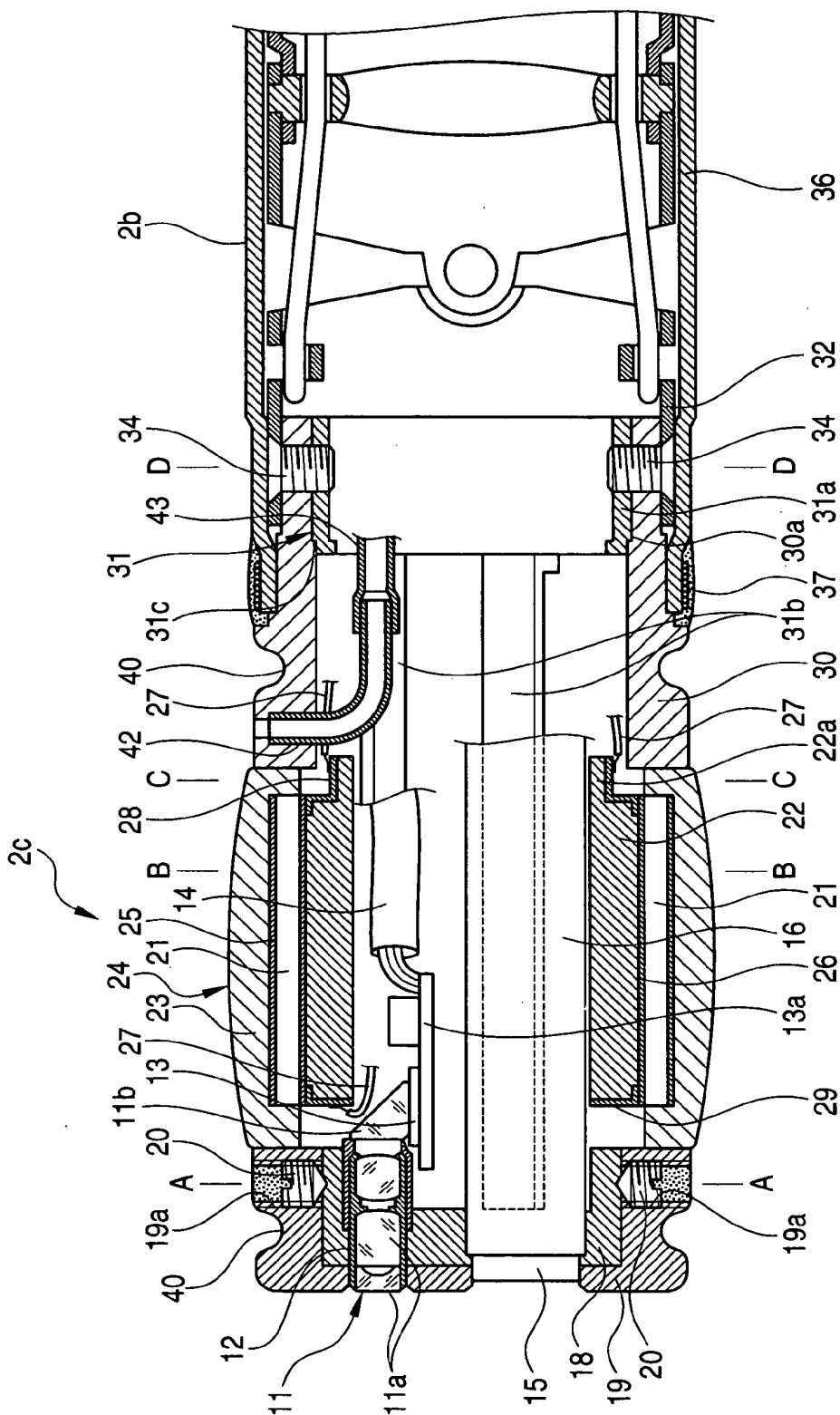

FIG. 5

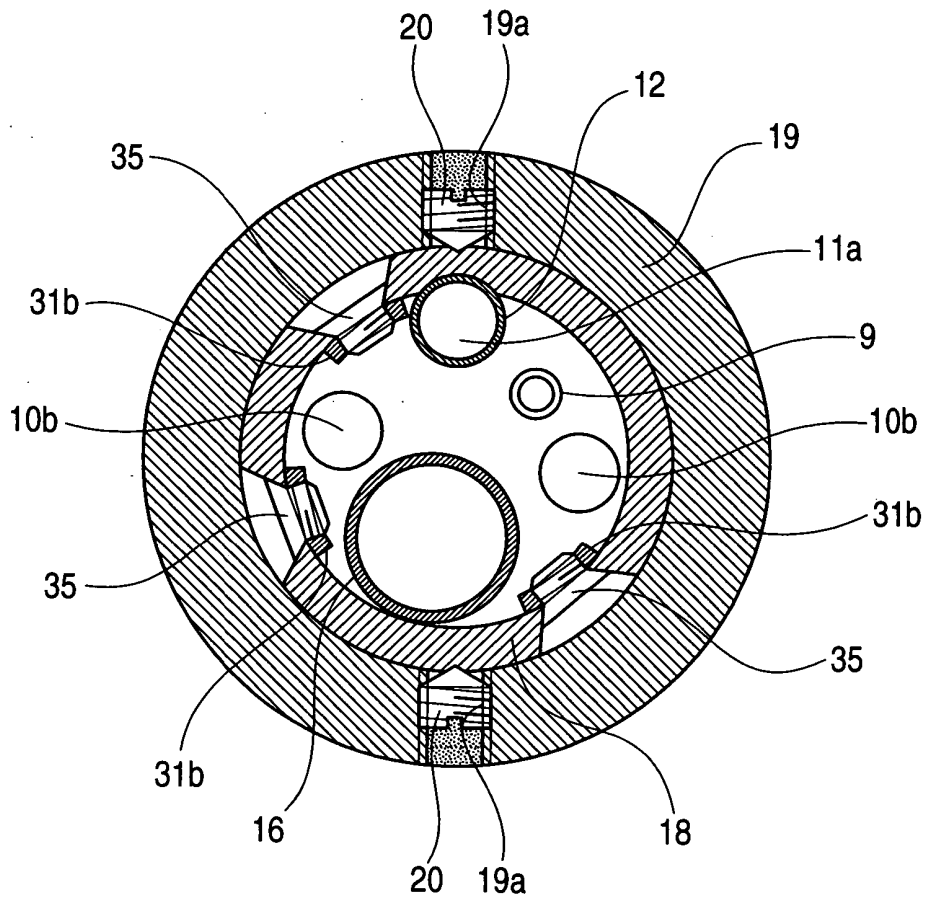

FIG. 6

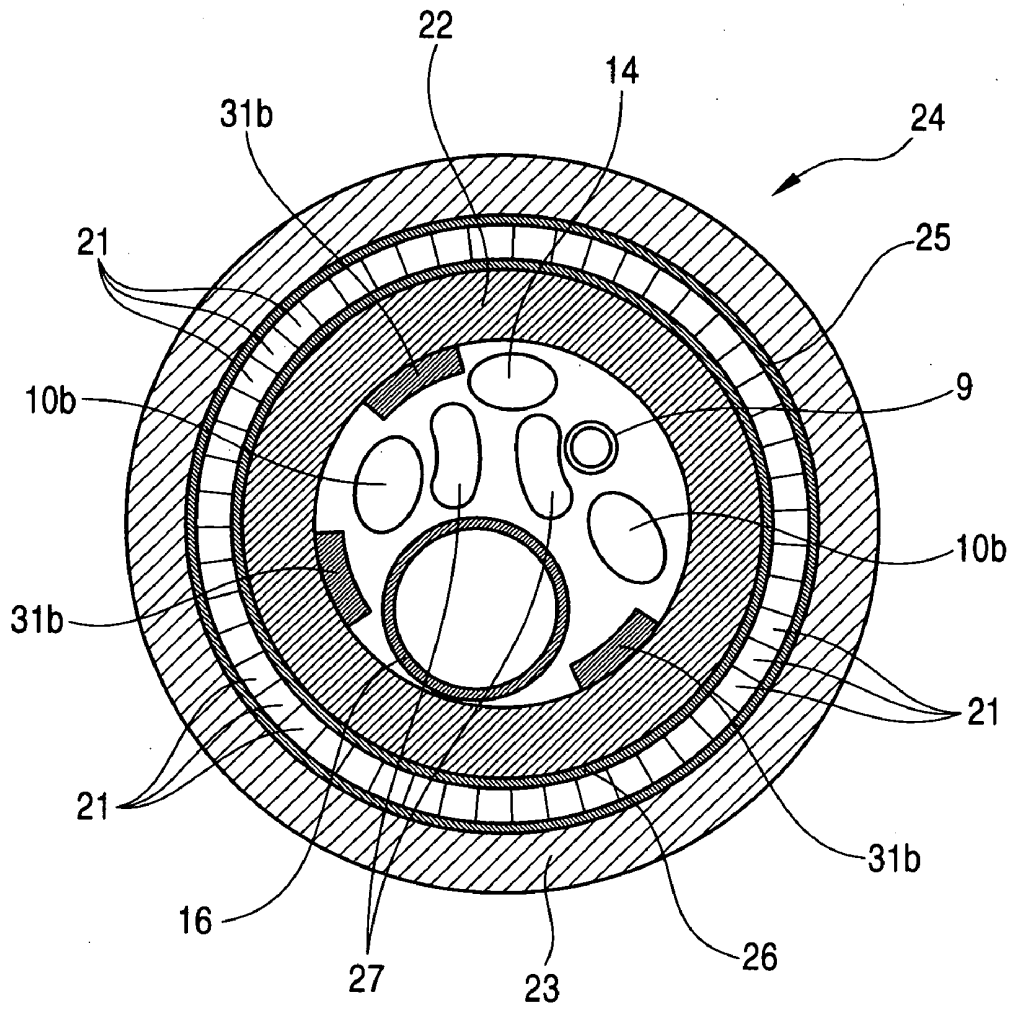

FIG. 7

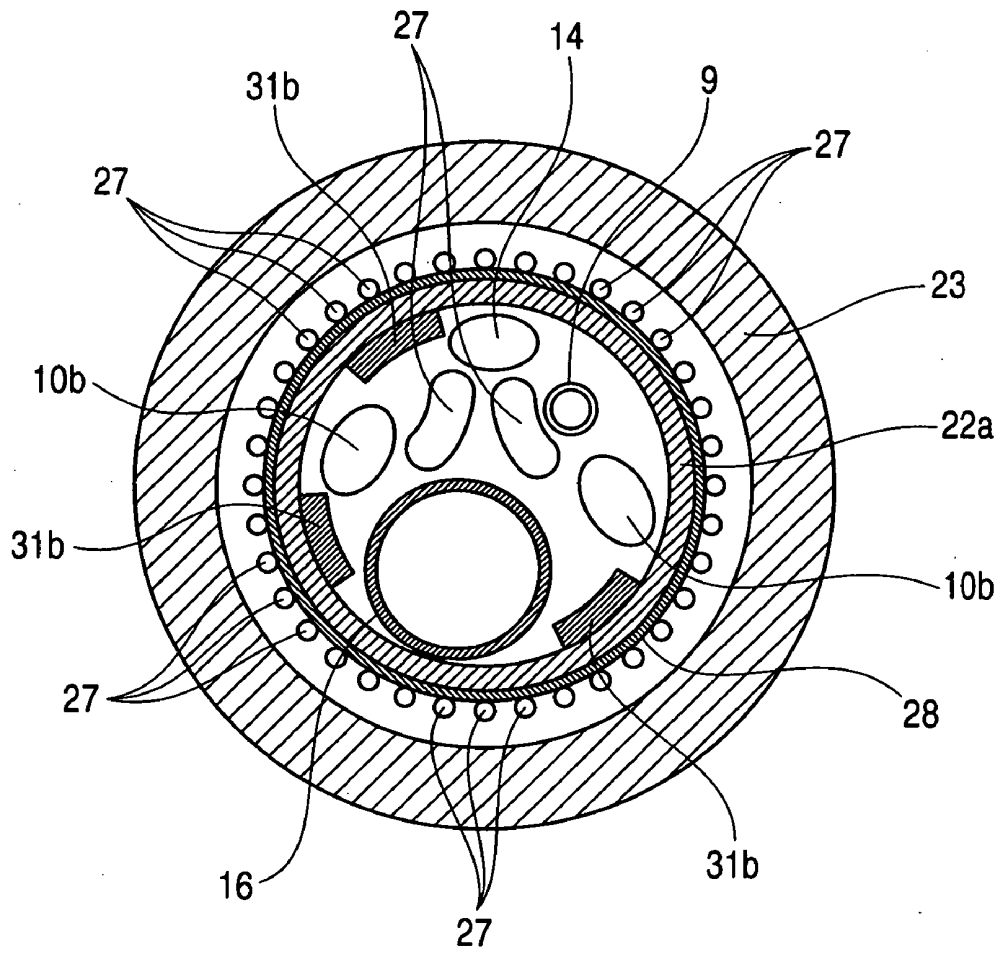

FIG. 8

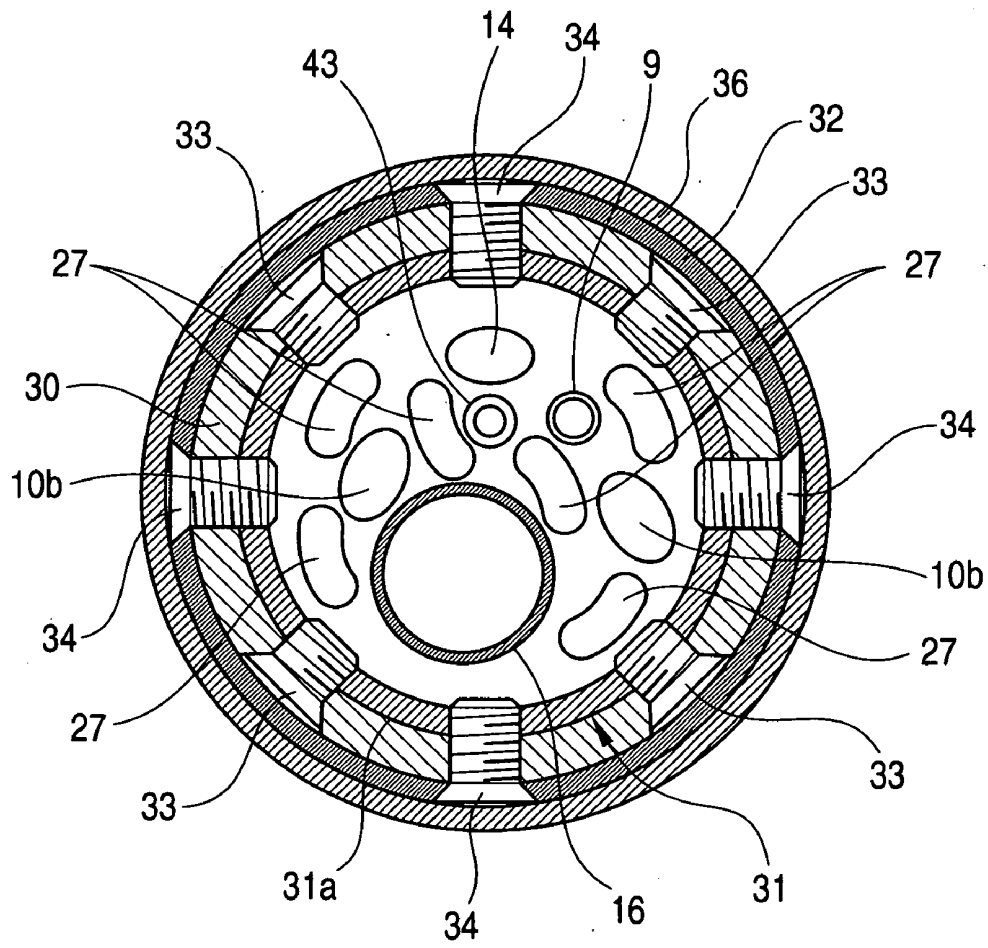

FIG. 9

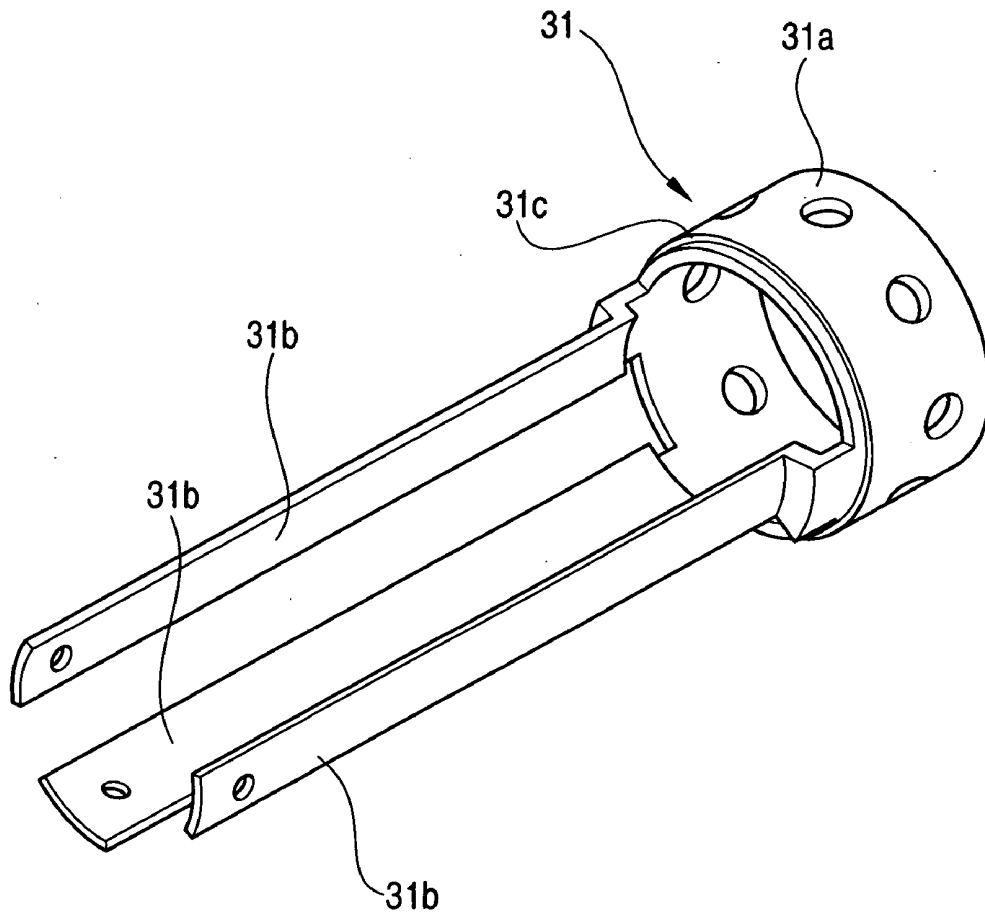

FIG. 10

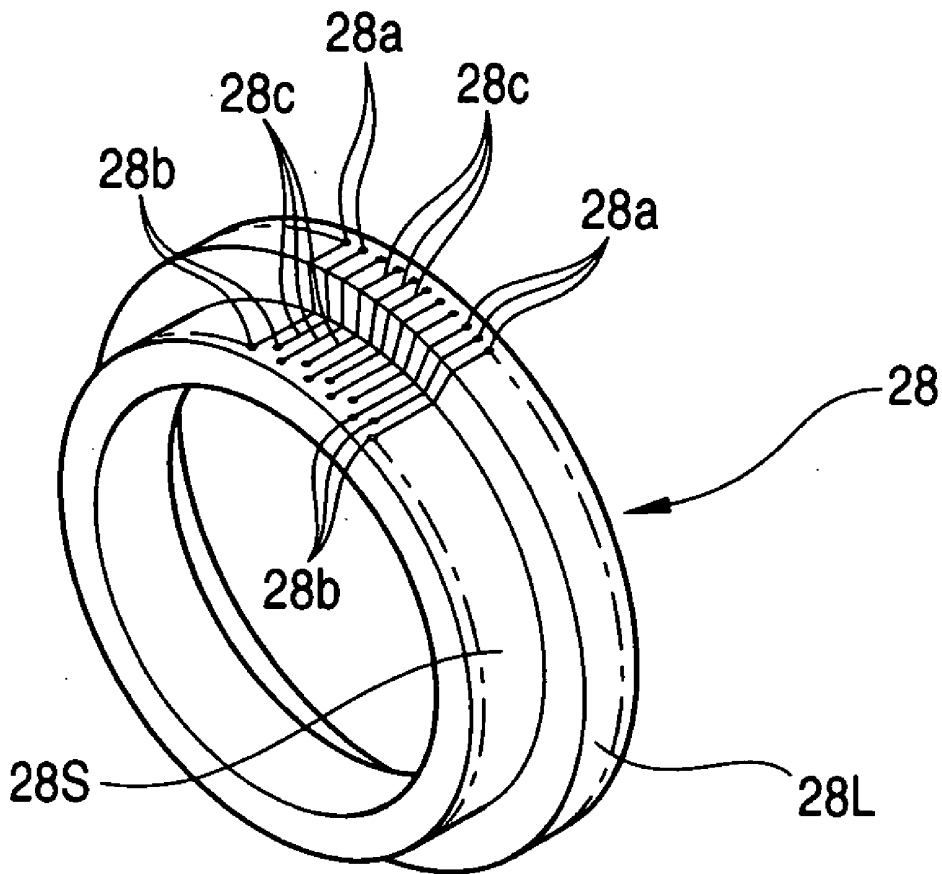

FIG. 11

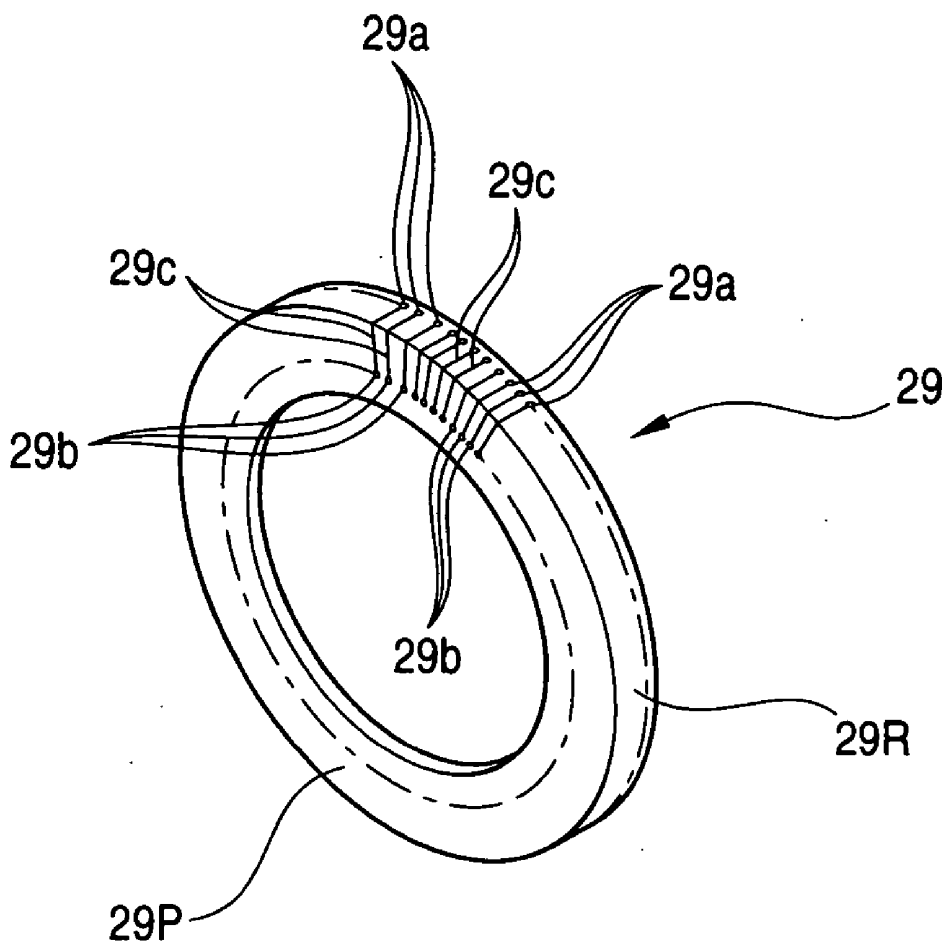
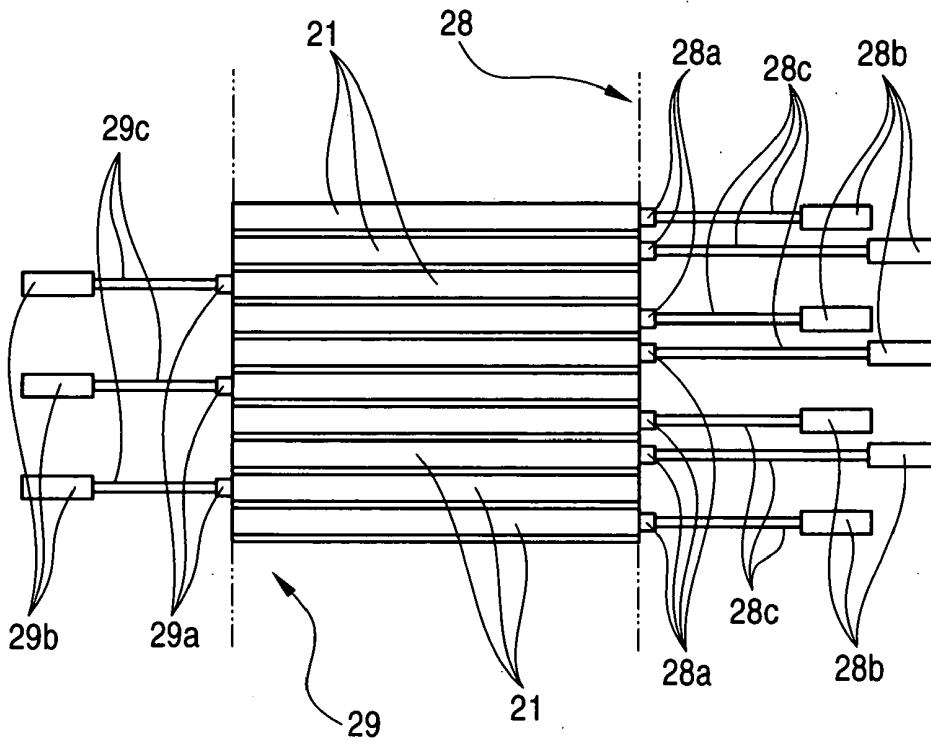

FIG. 12



ULTRASONIC ENDOSCOPE

BACKGROUND OF THE INVENTION

[0001] 1. Field of the Invention

[0002] The present invention relates to an ultrasonic endoscope in which an endoscopic observation section that has an observation visual field ahead of a distal hard part of an insertion portion and an electronic scanning type ultrasonic transducer that has a circumferential or circularly arcuate ultrasonic scan surface perpendicular to an axial line of the distal hard part are attached to the distal hard part.

[0003] 2. Description of the Related Art

[0004] An ultrasonic endoscope has a structure in which an endoscopic observation means and an ultrasonic transducer are attached to a distal hard part of an insertion portion that is inserted into, for example, a body cavity. As a scanning manner by this ultrasonic transducer, a so-called electronic scanning type ultrasonic transducer in which a large number of ultrasonic vibrators are arranged in a predetermined direction, and are sequentially driven is widely used in the related art. For example, JP-A-2001-314403 describes a direct-view endoscope in which an area in front of the distal hard part of the insertion portion is observed as an observation visual field in the endoscopic observation means, and an ultrasonic scan surface by the ultrasonic transducer is made to be radial, i.e., circumferential or arcuate within a predetermined angular range.

[0005] The ultrasonic endoscope disclosed by this JP-A-2001-314403 is inserted into, for example, body cavity tubes, i.e., upper alimentary canals, such as the esophagus and the duodenum, or lower alimentary canals, such as the large intestine, so that a forward area in the insertion direction is observed by the endoscopic observation means. As a result, if a region of interest, such as diseased parts, is detected, the ultrasonic transducer is positioned to face this region of interest, whereby information on body tissues of the region can be obtained.

[0006] Herein, wires are respectively connected to ultrasonic vibrators, which constitute the ultrasonic transducer, in the ultrasonic transducer. However, it is difficult to connect these wires directly to the ultrasonic vibrators. Therefore, in general, flexible boards are connected to the ultrasonic vibrators arranged in the circumferential direction, and terminal parts the number of which corresponds to the number of ultrasonic vibrators are formed on the flexible boards, and then the wires are connected to the terminal parts by, for example, a soldering means.

[0007] As described above, a large number of ultrasonic vibrators are arranged in the circumferential direction if the ultrasonic scan surface is in the radial direction. However, to heighten the resolution of an ultrasonic tomographic image, the number of ultrasonic vibrators is increased. From the viewpoint of making the diameter of the insertion portion smaller, the area of the flexible board cannot be widened. Therefore, in the flexible board, the distance between the terminals becomes close even if the wire-connecting terminals are zigzag arranged as a possible design. As a result, it becomes difficult to connect the wires to the terminals, and there is a possibility that connection strength will be weakened. Additionally, there is a possibility that, for example, a

short circuit is disadvantageously caused by allowing solder to overflow from the terminal part.

SUMMARY OF THE INVENTION

[0008] The present invention has been made in consideration of the foregoing circumstances. It is therefore an object of the present invention to electrically connect ultrasonic vibrators that constitute an ultrasonic transducer and wires together easily and stably.

[0009] To achieve the object, according to the present invention, there is provided an ultrasonic endoscope comprising an insertion portion comprising: an angle part; a distal hard part; a cylindrical body that connects the angle part and the distal hard part; an ultrasonic transducer attaching portion formed annularly; an endoscopic observation section attaching portion including a lighting portion and an observation portion, the lighting portion and the observation portion passing through an inside of the ultrasonic transducer attaching portion and facing a front edge surface of the distal hard part; an ultrasonic transducer in which a plurality of ultrasonic vibrators are arranged like a cylinder or like a circular arc so as to perform ultrasonic electronic scanning in a circumferential direction, the ultrasonic transducer being attached to the ultrasonic transducer attaching portion; a first flexible board connected to a distal end side of the ultrasonic transducer attaching portion, a second flexible board connected to a proximal end side of the ultrasonic transducer attaching portion, wherein the first flexible board comprises connection parts to electrodes of ones of the ultrasonic vibrators, the second flexible board comprises connection parts to electrodes of the other ones of the ultrasonic vibrators, each of the first and second flexible boards comprises a predetermined number of wire connection parts, wires are connected to each of the wire connection parts, those of the wires connected to the second flexible board are extended as they are, and the first flexible board or those of the wires connected to the first flexible board are extended toward the angle part through a hollow part of the ultrasonic transducer attaching portion.

[0010] Herein, a difference in the number of the wire connection parts can be made in both flexible boards although the flexible-board on the proximal end side and the flexible board on the distal end side can have the same number of connection parts. In this case, the wires connected to the flexible board on the distal end side undergo a turnabout from the forward side, and are drawn out toward the angle part through a hollow part of the ultrasonic transducer attaching portion. Therefore, the flexible board on the distal end side is inferior in the drawing-around condition to the flexible board on the proximal end side where the wires are drawn out toward the angle part without changes. Additionally, not only the wires from the ultrasonic vibrators but also members connected to the endoscope, such as signal cables from a light guide or a solid-state image pickup element and a treatment-instrument insertion channel, are passed through the inside of the hollow part in the ultrasonic transducer attaching portion. Therefore, a space used to pass the wires through the hollow part is restricted. For this reason, the number of the wires connected to the flexible board on the distal end side can be reduced. In other words, the second flexible board is greater in number of the connection parts to the electrodes of the ultrasonic vibrators than the first flexible board. With regard

to how to distribute the wires, regular distribution can be performed. For example, two adjoining electrodes of the ultrasonic vibrator are connected to the flexible board on the proximal end side, and a single electrode of the ultrasonic vibrator subsequent thereto is connected to the flexible board on the distal end side. Alternatively, from the positional relationship between the position of the ultrasonic vibrator and the position of another member, the wires can be distributed to the flexible board on the proximal end side and the flexible board on the distal end side so as to avoid mutual interference.

BRIEF DESCRIPTION OF THE DRAWINGS

[0011] FIG. 1 is a general schematic view of an ultrasonic endoscope that shows one embodiment of the present invention;

[0012] FIG. 2 is an external view of the distal end of an insertion portion;

[0013] FIG. 3 is a view showing the forward end surface of a distal hard part;

[0014] FIG. 4 is a longitudinal sectional view of the distal hard part;

[0015] FIG. 5 is a sectional view along line A-A of FIG. 4;

[0016] FIG. 6 is a sectional view along line B-B of FIG. 4;

[0017] FIG. 7 is a sectional view along line C-C of FIG. 4;

[0018] FIG. 8 is a sectional view along line D-D of FIG. 4;

[0019] FIG. 9 is an external perspective view of a bridging member;

[0020] FIG. 10 is an explanatory view that shows a structure of a flexible board on the proximal end side;

[0021] FIG. 11 is an explanatory view that shows a structure of a flexible board on the distal end side; and

[0022] FIG. 12 is an explanatory view that schematically shows the wire connection part of each flexible board on the proximal and distal end sides with respect to an ultrasonic vibrator.

DETAILED DESCRIPTION OF THE INVENTION

[0023] An embodiment of the present invention will be hereinafter described in detail with reference to the attached drawings. First, as shown in FIG. 1, an ultrasonic endoscope is roughly made up of a main control portion 1, an insertion portion 2, and a universal cord 3. A light source device, a video signal processor, and an ultrasonic wave observation device are connected to the ultrasonic endoscope, thus constituting a system as a whole. The universal cord 3 includes a connector 3a that is drawn out of the main control portion 1, then branches off in the middle thereof, and is detachably connected to the light source device, a connector 3b that is detachably connected to the video signal processor, and a connector 3c that is detachably connected to the ultrasonic wave observation device.

[0024] The main control portion 1 can be gripped by, for example, one hand of an operator, and is provided with an angle operating section 4 and a treatment-equipment introducing portion 5. The main control portion 1 is further provided with operating buttons, such as an air/water supply button 6 and a suction button 7, and various switches 8.

[0025] The insertion portion 2 is a code-like member that has a predetermined length and that is connected to the main control portion 1. The insertion portion 2 is inserted into, for example, the body of a subject. The insertion portion 2 is made up of a flexible part 2a, an angle part 2b, and a distal hard part 2c. The flexible part 2a occupies most of the length from a connection part to the main control portion 1, and is freely bent along an insertion path in a body cavity or the like. The angle part 2b is connected to an end of the flexible part 2a. The distal hard part 2c is connected to the angle part 2b. To direct the distal hard part 2c in a desired direction, the angle part 2b can be operated to be bent upwardly, downwardly, leftwardly, and rightwardly by remote control. Therefore, the angle operating section 4 is mounted on the main control portion 1. The angle part 2b is bent by the operation of an operator, and is controlled to direct the distal hard part 2c in a desired direction.

[0026] FIG. 2 shows a tip part of the insertion portion 2, and FIG. 3 shows a structure of an end surface of the distal hard part 2c of the insertion portion 2. As is apparent from these figures, the distal hard part 2c is provided with an endoscopic observation section and an electronic radial scan type ultrasonic transducer. The endoscopic observation section has a visual field in a direction of an extension line of its axial line, i.e., forward of the distal hard part 2c, and has a predetermined visual angle V. The electronic radial scan type ultrasonic transducer has a circular or circularly arcuate ultrasonic scan surface W at a position closer to the proximal end than the visual field of the endoscopic observation section.

[0027] FIG. 4 is a cross-sectional view of the tip part of the insertion portion 2. As is apparent from this figure and FIG. 3, the endoscopic observation section is made up of a plurality of lighting portions 10 and an observation portion 11. The lighting portions 10 are disposed at both side positions, respectively, with the observation portion 11 therebetween. The lighting portion 10 includes a lighting lens 10a, which faces the end surface of the distal hard part 2c, and a light guide 10b (see FIG. 5 to FIG. 8). The light guide 10b is made of a large number of bundles of extra-fine optical fibers, and is extended from the connector 3a of the universal cord 3 to the distal hard part 2c of the insertion portion 2. An illumination light emitting end of the light guide 10b is positioned to face the lighting lens 10a. On the other hand, the observation portion 11 is made up of an objective lens 11a and a prism 11b by which an optical path from the objective lens 11a is bent by 90°. The objective lens 11a is disposed in a lens tube 12, and the prism 11b is fixed to the lens tube 12. A solid-state image pickup element 13 is joined to the prism 11b. A predetermined number of signal lines are connected to a substrate 13a of the solid-state image pickup element 13. The signal lines are bundled into a single video cable, and are extended to the connector 3b of the universal cord.

[0028] A treatment equipment lead-out opening 15 used to outwardly lead forceps and other pieces of treatment equip-

ment is further provided at the end surface of the distal hard part **2c** of the insertion portion **2**. A connection pipe **16**, to which a treatment-equipment passing tube from the treatment-equipment introducing portion **5** mounted on the main control portion **1** is connected, is attached to the treatment equipment lead-out opening **15**. The treatment-equipment passing tube is formed so as to be joined with a suction path inside the main control portion **1**. Further, a nozzle **17** used to wash the objective lens **12** when the end surface of the objective lens **12** of the observation portion **11** is stained with body fluids or the like is attached to the distal hard part **2c**. A fluid supply tube **9** for washing which is operated by the air/water supply button **6** (see **FIG. 5** to **FIG. 8**) is connected to the nozzle **17**.

[0029] The endoscopic observation section is structured in this way. The forward end of each member that constitutes the endoscopic observation section is firmly held by an endoscope attaching member **18**. The endoscope attaching member **18** is made of a metallic material, such as stainless steel, having a plurality of through-holes through which each member constituting the endoscopic observation section is passed. A forward end cap **19** is fitted to the endoscope attaching member **18**. The forward end cap **19** prevents the endoscope attaching member **18** made of the metallic material from being exposed to the outside. The endoscope attaching member **18** and the forward end cap **19** constitute a forward end block. As shown in **FIG. 5**, the forward end cap **19** has two threaded holes **19a** in its thickness direction. Setscrews **20** are screwed into the threaded holes **19a**, respectively, and the forward end of the setscrew **20** is pressed against the endoscope attaching member **18**. In addition, a contact surface of the endoscope attaching member **18** and a contact surface of the forward end cap **19** are bonded together, whereby the forward end block made up of the endoscope attaching member **18** and the forward end cap **19** is unified.

[0030] A mechanism to perform an ultrasonic examination including a scan surface in the radial direction is provided at a position on the proximal end side of the forward end cap **19** of the distal hard part **2c**. As is apparent from **FIG. 6**, this mechanism is made up of an array of a large number of ultrasonic vibrators arranged in a circumferential direction. The ultrasonic vibrators **21** are arranged in the form of a circle or a circular arc (for example, an angle of 270 degrees or more) so as to perform electronic scanning. A backing layer **22** is mounted on the inner circumference side of the ultrasonic vibrators **21** arranged in this way, and a sound lens **23** is mounted on the outer circumference side thereof. The ultrasonic vibrators **21**, the backing layer **22**, and the sound lens **23** constitute an ultrasonic transducer **24**.

[0031] Each ultrasonic vibrator **21** has two electrodes **25** and **26**. The electrode **25** that is one of the two electrodes is a common electrode **25** shared among all of the ultrasonic vibrators **21** (or among each set of a predetermined number of ultrasonic vibrators **21**), whereas the other electrode **26** is individually used for each ultrasonic vibrator **21**. The individual electrode **26** of the ultrasonic vibrators **21** is connected to wires **27**. For this reason, flexible boards **28** and **29** are connected to the front and the rear of the ultrasonic transducer **24**, respectively. The wires **27** are electrically connected to wiring patterns formed on the flexible boards **28** and **29**. On the other hand, what is needed for the common electrode **25** is to be connected to at least one wire.

For this reason, the common electrode **25** is connected to either the flexible board **28** or the flexible board **29**.

[0032] The ultrasonic transducer **24** is shaped roughly like a cylinder. The inner circumferential surface of the ultrasonic transducer **24** serves as a tunnel-like passage. Each member that constitutes the endoscopic observation section is inserted into the inside of the tunnel-like passage by the ultrasonic transducer **24**, and is positioned closer to the forward end than the ultrasonic transducer **24**, and is fixed to the endoscope attaching member **18** covered with the forward end cap **19**. The distal end of the ultrasonic transducer **24** is in contact with the end surface of the forward end cap **19**, and the proximal end thereof is in contact with the end surface of the connection member **30**. The connection member **30** forms a connection part to the angle part **2b** in the distal hard part **2c**.

[0033] Further, abridging member **31** is provided inside a connecting member **30**. A forefront ring **32** in an angle ring that forms the structure of the angle part **2b** is connected to the connecting member **30** and the bridging member **31**. For this reason, as is apparent from **FIG. 8**, the connecting member **30** and the bridging member **31** are connected together by a plurality of screws **33**, and the forefront ring **32** is connected to these members by a plurality of screws **34**.

[0034] The bridging member **31** can fulfill the function of connecting a top ring **32** occupying the forefront position of the angle part **2b** together with the connecting member **30** disposed closest to the proximal end in the distal hard part **2c**, the function of positionally restricting the ultrasonic transducer **24** in a direction perpendicular to the axial line of the distal hard part **2c**, and the function of forming a connection to a combination of the endoscope attaching member **18** and the forward end cap **19**. Therefore, the bridging member **31** is required to have high strength, and is made of a metal, such as stainless steel, because the bridging member **31** is not exposed to the outside. As shown in **FIG. 9**, a part of the bridging member **31** that is connected to the connecting member **30** and to the forefront ring **32** of the angle part **2b** by the screws **33** and **34** is a cylindrical part **31a**. A plurality of connecting arms **31b** (in this embodiment, three arms) are extended toward the forward end from this cylindrical part **31a**.

[0035] The ultrasonic transducer **24** is positioned in the direction perpendicular to the axial line by being fitted to the connecting arm **31b**. The forward end of each connecting arm **31b** and the endoscope attaching member **18** are connected together by the screw **35**. A step (i.e., a difference in level) **31c** is formed on the outer circumferential surface of the cylindrical part **31a** of the bridging member **31**. This step **31c** makes the diameter on the proximal end side larger. Further, a step **30a** is formed on the inner circumferential surface of the connecting member **30**. This step **30a** makes the diameter of the inner circumferential surface on the proximal end side larger. The ultrasonic transducer **24** is sandwiched between the forward end cap **19** and the connecting member **30** by joining the step **31c** and the step **30a** together. Both end surfaces of the ultrasonic transducer **24**, the proximal end surface of the forward end cap **19**, and the distal end surface of the connecting member **30** are bonded together, and, as a result, the ultrasonic transducer **24** is positioned in the direction of the axial line and is prevented

from being moved, and hence the ultrasonic transducer **24** is fixedly held at a predetermined position. An outer hull layer **36** of the angle part **2b** is extended to an outer-circumferential-surface part on the proximal end side of the connecting member **30**. The forward end of the outer hull layer **36** is fixed to the connecting member **30** of the distal hard part **2c** by a fixing mechanism **37** made up of a spool and an adhesive.

[0036] In the ultrasonic endoscope, ultrasonic waves are sent toward the body from each ultrasonic vibrator **21** that constitutes the ultrasonic transducer **24**, and reflection echoes emitted from a sectional region of tissues in the body are received. To restrain the attenuation of the ultrasonic waves sent and received in this way, annular concave grooves **40** and **40** are provided at positions before and behind the attaching member of the ultrasonic transducer **24**, i.e., on the outer circumferential surface of the forward end cap **19** and the outer circumferential surface of the connecting member **30**, respectively. As is apparent from FIG. 2, a balloon **41** that is filled and inflated with an ultrasonic wave transmission medium is attached between both annular concave grooves **40** and **40**. This balloon **41** is made of a cylindrical, flexible film **41a**. Fixed rings **41b**, which are fixed to the annular concave grooves **40**, are respectively provided on both ends of the flexible film **41a**. The fixed ring **41b** is fixed so that a tightening force acts on the annular concave groove **40**. A supply/drain path **42** used to supply and drain the ultrasonic wave transmission medium into the balloon **41** is bored in the connecting member **30**. A tube **43** is connected to the supply/drain path **42**.

[0037] With the structure formed in this way, the insertion portion **2** is inserted into the body cavity of a subject. Thereafter, illumination light is projected from the lighting portion **10** that forms the endoscopic observation section into the body cavity, and an image of the body cavity is formed on a solid-state image pickup element **13** by the objective lens **12** attached to the observation portion **11**. Thereafter, a video signal of the body cavity is obtained by the solid-state image pickup element **13**, and is sent to the video signal processor. In the video signal processor, predetermined signal processing is performed, and the image of the body cavity is displayed on a monitor for displaying endoscopic images. Therefore, an endoscopic examination concerning the state of the body cavity can be performed by watching the monitor.

[0038] If a region of interest, such as a diseased part, is found as a result of this endoscopic examination, the ultrasonic transducer **24** is moved to the position facing this region of interest. In other words, the ultrasonic transducer **24** is placed at the position facing the region of interest by advancing the insertion portion **2** by a predetermined distance. An ultrasonic wave transmission medium is then supplied into the balloon **41**, so that the flexible film **41a** is expanded and brought into close contact with the inner wall of the body cavity. In this state, the ultrasonic vibrators **21** that form the ultrasonic transducer **24** and that are arranged in the circumferential direction are sequentially operated to send an ultrasonic pulse toward the body and receive a reflection echo thereof. Herein, some of the ultrasonic vibrators **21** are operated with a predetermined delay although the ultrasonic vibrators **21** can be operated sequentially one by one. Accordingly, for example, electronic focusing can be performed. Since a method in which a large

number of ultrasonic vibrators **21** arranged as above are subjected to electronic scanning is known in the related art, a description of this method is omitted.

[0039] A reflection echo signal obtained by each ultrasonic vibrator **21** that constitutes the ultrasonic transducer **24** in this way is sent to the ultrasonic wave observation device by the connector **3c** of the universal cord **3** through the wires **27** (which are bundled in the middle thereof), and is subjected to signal processing by the ultrasonic wave observation device. As a result, tomographic information concerning the state of the bodily tissues including the region of interest is obtained. This ultrasonic tomographic image is then displayed on the monitor attached to the ultrasonic wave observation device. As a result, for example, diagnosis of whether a diseased part is included in the tissues can be performed.

[0040] By the way, the ultrasonic vibrators **21** large in number and the wires **27** are electrically connected together through the flexible boards **28** and **29**. These flexible boards **28** and **29** are disposed in such a way as to be sandwiched between the ultrasonic vibrator **21** and the backing layer **22**. The flexible board **28** is extended toward the proximal end of the ultrasonic transducer **24**, and the flexible board **29** is disposed on the distal end of the ultrasonic transducer **24**.

[0041] Next, the flexible board **28** is shown in FIG. 10, and the flexible board **29** is shown in FIG. 11. As is apparent from these figures, necessary wiring patterns are formed on the flexible boards **28** and **29** by, for example, a printing section. The wiring pattern is made up of first terminal parts **28a** and **29a** electrically connected to the individual electrodes **26**, respectively, of the ultrasonic vibrator **21**, second terminal parts **28b** and **29b** electrically connected to the wires **27** by, for example, a soldering section, and wires **28c** and **29c** through which the first and second terminal parts are connected together.

[0042] These flexible boards **28** and **29** are incorporated into the distal hard part **2c** in the shape of a cylinder as a whole. A part on the side of which the first terminal parts **28a** and **29a** are disposed is interposed between each ultrasonic vibrator **21** that constitutes an array of ultrasonic vibrators annularly arranged and the backing layer **22**. On the other hand, parts at which the second terminal parts **28b** and **29b** of the flexible boards **28** and **29** are disposed are respectively extended to the proximal end side and the distal end side of the ultrasonic transducer **24**.

[0043] As is apparent from FIG. 10, the flexible board **28** extended to the proximal end of the ultrasonic transducer **24** has a large-diameter part **28L** and a small-diameter part **28S** by both of which a step (i.e., a difference in level) is formed. An extension part **22a** is formed on the proximal end side of the backing layer **22** closer to the proximal end than the ultrasonic vibrator **21**. As is apparent from FIG. 4, the large-diameter part **28L** of the flexible board **28** is interposed between the ultrasonic vibrator **21** and the backing layer **22**. The small-diameter part **28S** of the flexible board **28** is joined to the extension part **22a**. The second terminal part **28b** is formed at the position of the small-diameter part **28S** located on the extension part **22a**. The wire **27** is connected to this location, and is extended from this connection part to the side of the angle part **2b** through the inside of the connecting member **30**. Herein, the bridging member **31** is connected to the connecting member **30**. The connecting

arm **31b** of the bridging member **31** is extended to the distal end through the inside of the backing layer **22**. Therefore, the wires **27** are guided inside the bridging member **31** in such a manner as to avoid the plurality of connecting arms **31b**, and are bundled into a single group of wires or into a plurality of groups of wires. Therefore, in the figures, reference numeral **27** is given also to the bundled wires **27**.

[0044] As is apparent from **FIG. 11**, the flexible board **29** located on the distal end side of the ultrasonic transducer **24** includes a cylindrical part **29R** and an annular part **29P**. The cylindrical part **29R** is interposed between the ultrasonic vibrator **21** and the backing layer **22**. The annular part **29P** is joined to the end surface of the backing layer **22**. The first terminal part **29a** is formed on the cylindrical part **29R**, and the second terminal part **29b** is formed on the annular part **29P**. Therefore, the wires **27** are connected at the position of the annular part **29P** of the flexible board **29**. The wires **27** change its direction at a gap between the ultrasonic transducer **24** and the forward end block made up of the endoscope attaching member **18** and the forward end cap **19**, and are bundled into a plurality of groups of wires. The thus bundled wires **27** are passed through the tunnel-like passage inside the ultrasonic transducer **24**, and are extended toward the angle part **2b**. In this case, it is preferable to seal the connection part to the flexible board **29** of the wires **27** with resin.

[0045] As described above, the wires **27** connected to the large number of ultrasonic vibrators **21** that constitute the ultrasonic transducer **24** are distributed into the proximal end side and the distal end side. This distribution ratio can be set at the ratio of 2 of the proximal end side to 1 of the distal end side as shown in **FIG. 12**. The second terminal parts **28b** and **29b** of the flexible boards **28** and **29** provided on the proximal and distal end sides can be enlarged by zigzag arranging the second terminal parts **28b** provided on the flexible board **28** on the proximal end side. Therefore, the wires **27** connected by soldering can be firmly fixed. At this time, solder never overflows so as to short-circuit with other terminal parts.

[0046] The distribution of the wires **27** into both of the flexible boards **28** and **29** can be appropriately set in consideration of, for example, the position of the connecting arm **31b** of the bridging member **31** disposed inside the flexible boards **28** and **29** or the position of each member that constitutes the endoscopic observation section. The distribution ratio can be set not at the ratio of 2:1 mentioned above but at an arbitrary distribution ratio. The flexible board **29** connected to the distal end side may be formed such that another cylindrical part is consecutively formed at the forward end of the annular part **29P**, and the cylindrical part extended in this way is bonded with the inner surface of the backing layer **22** in the ultrasonic transducer **24** that forms the tunnel-like passage, and is connected to the wire **27** at the position of the proximal end of the backing layer **22**.

[0047] The interval between the wire connection parts formed on the flexible boards can be widened by employing the foregoing structure, and the wire-connecting operation

can be easily performed. Additionally, advantageously, the wires can be firmly fixed, and hence there is no fear that a short circuit or the like will be caused.

[0048] The entire disclosure of each and every foreign patent application from which the benefit of foreign priority has been claimed in the present application is incorporated herein by reference, as if fully set forth.

What is claimed is:

1. An ultrasonic endoscope comprising

an insertion portion comprising:

an angle part;

a distal hard part;

a cylindrical body that connects the angle part and the distal hard part;

an ultrasonic transducer attaching portion formed annularly;

an endoscopic observation section attaching portion including a lighting portion and an observation portion, the lighting portion and the observation portion passing through an inside of the ultrasonic transducer attaching portion and facing a front edge surface of the distal hard part;

an ultrasonic transducer in which a plurality of ultrasonic vibrators are arranged like a cylinder or like a circular arc so as to perform ultrasonic electronic scanning in a circumferential direction, the ultrasonic transducer being attached to the ultrasonic transducer attaching portion;

a first flexible board connected to a distal end side of the ultrasonic transducer attaching portion,

a second flexible board connected to a proximal end side of the ultrasonic transducer attaching portion,

wherein the first flexible board comprises connection parts to electrodes of ones of the ultrasonic vibrators,

the second flexible board comprises connection parts to electrodes of the other ones of the ultrasonic vibrators,

each of the first and second flexible boards comprises a predetermined number of wire connection parts,

wires are connected to each of the wire connection parts,

those of the wires connected to the second flexible board are extended as they are, and

the first flexible board or those of the wires connected to the first flexible board are extended toward the angle part through a hollow part of the ultrasonic transducer attaching portion.

2. The ultrasonic endoscope according to claim 1,

wherein the second flexible board is greater in number of the connection parts to the electrodes of the ultrasonic vibrators than the first flexible board.

* * * * *

专利名称(译)	超声波内窥镜		
公开(公告)号	US20060241481A1	公开(公告)日	2006-10-26
申请号	US11/392707	申请日	2006-03-30
[标]申请(专利权)人(译)	富士写真光机株式会社		
申请(专利权)人(译)	FUJINON CORPORATION		
当前申请(专利权)人(译)	FUJINON CORPORATION		
[标]发明人	ITOI HIROMU		
发明人	ITOI, HIROMU		
IPC分类号	A61B8/14		
CPC分类号	A61B1/0051 A61B8/445 A61B8/4488 A61B8/12		
优先权	2005100552 2005-03-31 JP		
其他公开文献	US7744539		
外部链接	Espacenet	USPTO	

摘要(译)

插入部分中的远端硬质部分设置有超声波换能器，其中大量超声波振动器沿圆周方向布置。超声波换能器的形状像圆柱体。构成内窥镜观察部分的每个构件穿过该隧道状通道。每个超声波振动器设置有单个公共电极和单个电极，其数量对应于超声波振动器的数量。柔性板并设置在超声换能器的近端侧和远端侧。电线连接到这些柔性板。来自柔性板的导线无延伸地延伸，而来自柔性板的导线从远端侧反向转动，然后穿过隧道状通道，并沿角度部分的方向延伸。

