



(19) **United States**

(12) **Patent Application Publication**  
**Hyun**

(10) **Pub. No.: US 2006/0173315 A1**  
(43) **Pub. Date: Aug. 3, 2006**

(54) **CLIENT/SERVER-BASED ULTRASOUND DIAGNOSTIC SYSTEM**

**Publication Classification**

(75) Inventor: **Dong Gyu Hyun**, Gwangju-si (KR)

(51) **Int. Cl.**  
*A61B 8/00* (2006.01)  
(52) **U.S. Cl.** ..... **600/437**

Correspondence Address:  
**OBLON, SPIVAK, MCCLELLAND, MAIER & NEUSTADT, P.C.**  
**1940 DUKE STREET**  
**ALEXANDRIA, VA 22314 (US)**

(57) **ABSTRACT**

The present invention relates to a client/server-based ultrasound diagnostic system. The client/server-based ultrasound diagnostic system comprises: a client configured to comprise a probe for transducing an electric signal into an ultrasound signal, and vice versa, a beam former for transceiving the electric signal from/to the probe, and a display unit; and a server configured to comprise a control unit for controlling the probe and the beam former, and an image process for generating an ultrasound image signal based on the electric signal received from the client for transmission of the generated ultrasound image signal to the display unit.

(73) Assignee: **Medison Co., Ltd.**, Hongchun-gun (KR)

(21) Appl. No.: **11/223,122**

(22) Filed: **Sep. 12, 2005**

(30) **Foreign Application Priority Data**

Jan. 7, 2005 (KR) ..... 10-2005-0001681

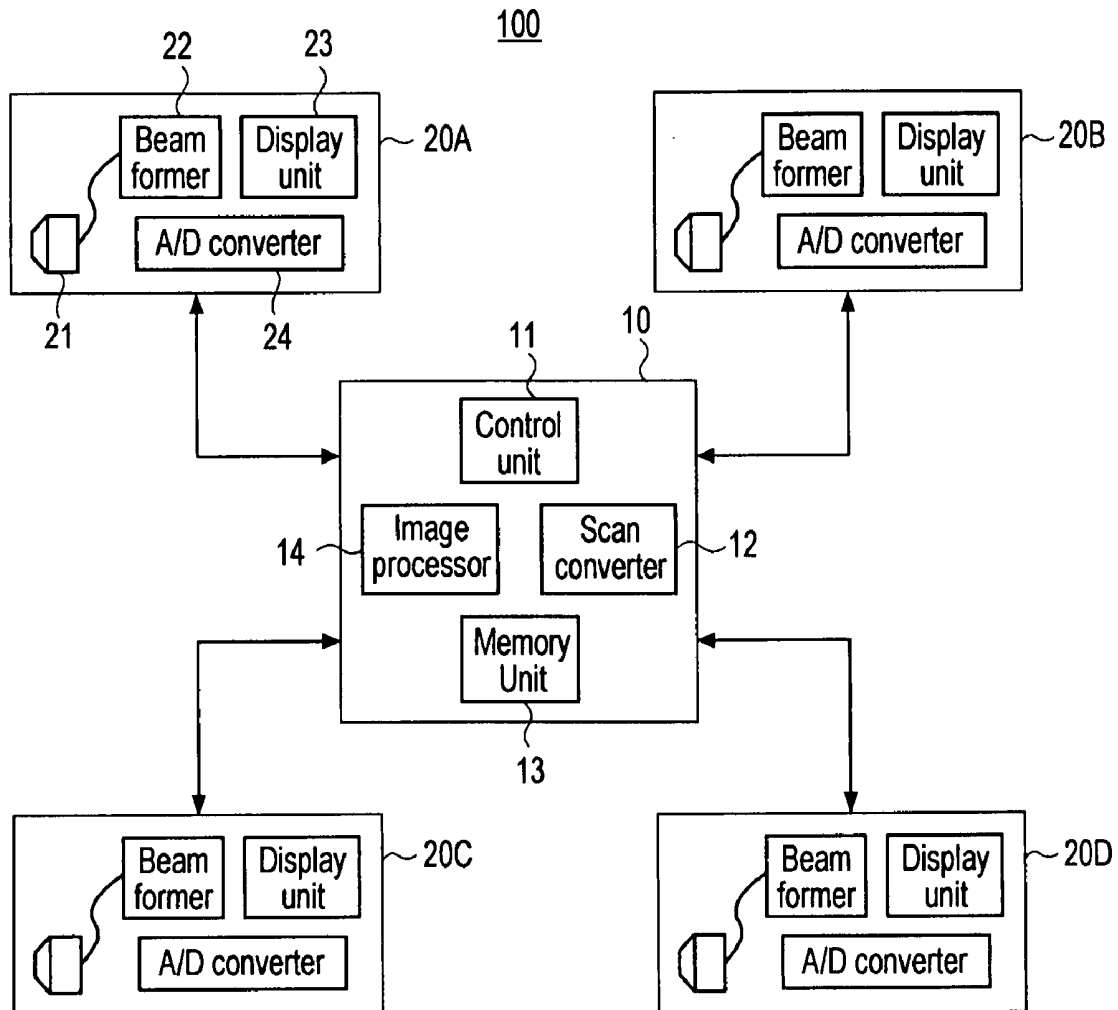

Fig. 1

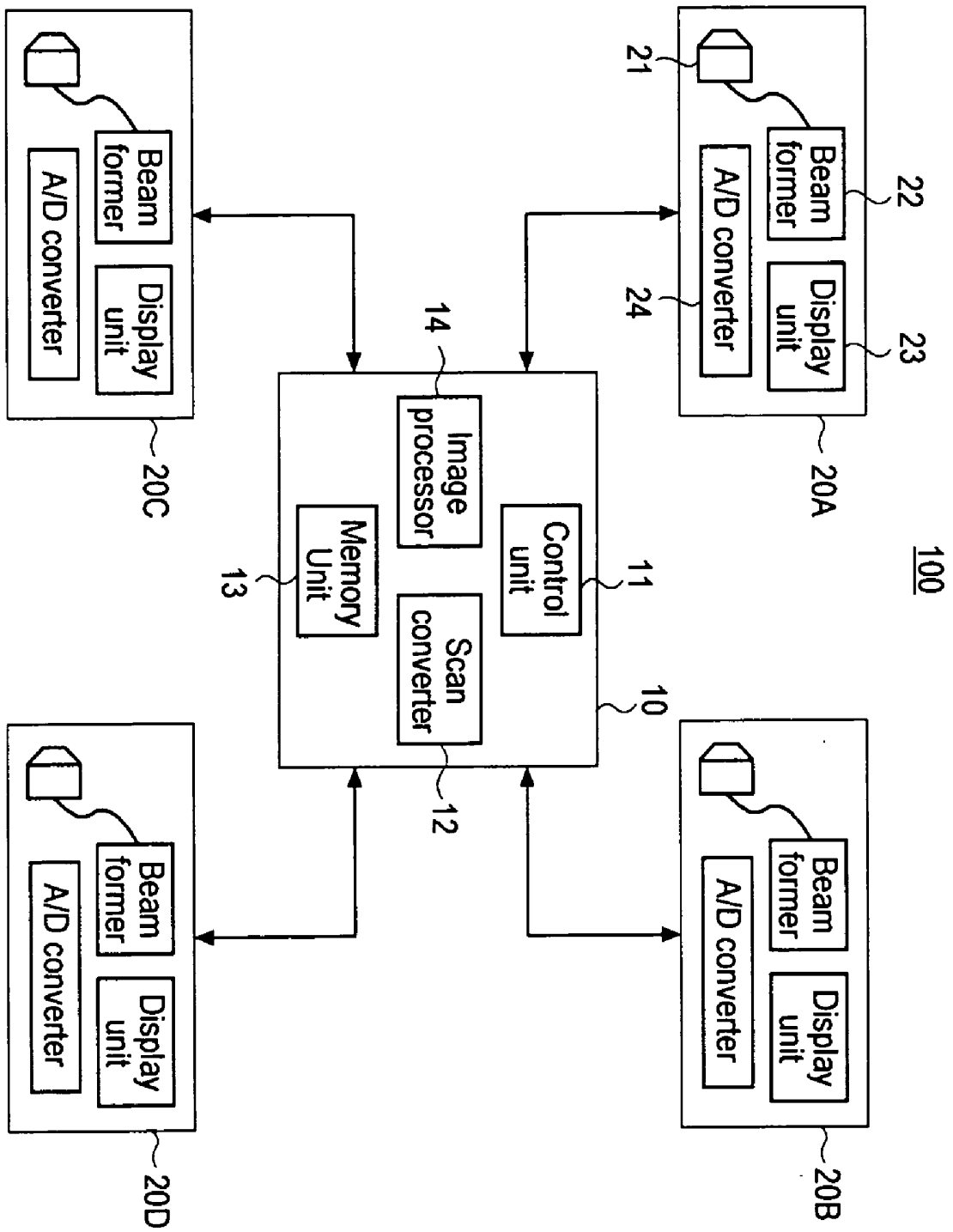
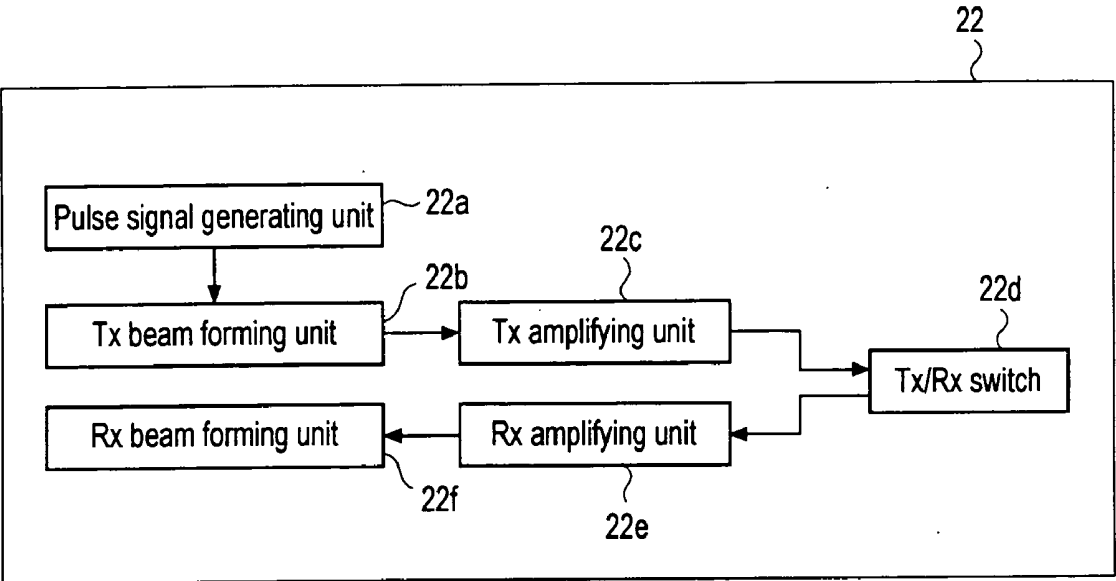

Fig. 2



## CLIENT/SERVER-BASED ULTRASOUND DIAGNOSTIC SYSTEM

### FIELD OF THE INVENTION

[0001] The present invention generally relates to an ultrasound diagnostic system, and more particularly to a client/server-based ultrasound diagnostic system.

### BACKGROUND OF THE INVENTION

[0002] An ultrasound diagnostic system is known as medical equipment for obtaining information on the internal organs of the human body in a non-destructive manner. The ultrasound diagnostic system operates to irradiate an ultrasound signal through the surface of the human body to the selected internal organ and receives the echo signal reflected from the internal organ. The echo signal is then processed to provide, for example, a cross-sectional image of a soft tissue or bloodstream within the human body.

[0003] As is well known, the ultrasound diagnostic system is smaller in size and is cheaper compared to other image diagnostic devices (e.g., X-ray diagnostic device, X-ray computer tomography (CT) scanner, magnetic resonance imaging (MRI), nuclear medicine diagnostic device, etc.). The ultrasound diagnostic system can safely provide a bloodstream image since it does not require the human body to be exposed to an X-ray.

[0004] A conventional ultrasound diagnostic system generally consists of three parts: a front end for receiving ultrasound signals; a back end for processing the received ultrasound signals; and a host processor in charge of controlling the overall system in response to the user control and for displaying the results of the processing. However, the conventional system is disadvantageous since its parts are not replaceable. That is, even if one part of the system has been upgraded in terms of function, the user must newly purchase the entire system as upgraded if he/she wishes to utilize the upgraded function. For example, if only the function of the back end has been upgraded, the user must purchase a new ultrasound diagnostic system in order to utilize the upgraded function of the back end, even though the functions of the front end and the host processor remain the same as the old system. Further, given that a processor of the host processor is continuously improved, it would be disadvantageous for a user to purchase a new ultrasound diagnostic system whenever a newly developed processor is adopted.

[0005] Another disadvantage of the conventional system is that the required functions of the ultrasound diagnostic system may vary depending on a particular medical field. Therefore, it would be disadvantageous to develop an ultrasound diagnostic system specific for each medical field.

### SUMMARY OF THE INVENTION

[0006] It is an objective of the present invention to provide a client/server-based ultrasound diagnostic system that allows the functions of each respective unit to be individually upgraded, as well as being adapted to control a plurality of front ends simultaneously.

[0007] In accordance with an aspect of the present invention, there is provided a client/server-based ultrasound diagnostic system, comprising: at least one client comprising a

probe for transducing an electric signal into an ultrasound signal, and vice versa, a beam former for transceiving the electric signal from/to the probe, and a display unit; and a server for controlling the probe and the beam former, generating an ultrasound image signal based on the electric signal received from the client, and transmitting the generated ultrasound image signal to the display unit.

[0008] In accordance with another aspect of the present invention, there is provided a client/server-based ultrasound diagnostic system, comprising: at least one client configured to comprise, a probe for transducing an electric pulse signal into an ultrasound signal, and vice versa; a beam former which comprises a pulse signal generating unit for generating a plurality of electric pulse signals, a transmit beam forming unit for forming a transmit beam by delaying the electric pulse signals received from the pulse signal generating unit, and a receive beam forming unit for forming a receive beam by delaying the electric pulse signals received from the probe; an analog/digital converter for converting the receive beam into a digital receive signal; and a display unit, and a server configured to comprise, a digital scan converter for forming image data based on the digital receive signal received from the analog/digital converter; and an image processor for processing the image data received from the digital scan converter for transmission of the processed image data to the display unit.

### BRIEF DESCRIPTION OF THE DRAWINGS

[0009] The above and other objects and features of the present invention will become apparent from the following description of preferred embodiments provided in conjunction with the accompanying drawings, in which:

[0010] **FIG. 1** is a block diagram illustrating a client/server-based ultrasound diagnostic system in accordance with the present invention; and

[0011] **FIG. 2** is a block diagram illustrating a beam former of **FIG. 1**.

### DETAILED DESCRIPTION OF THE PRESENT INVENTION

[0012] **FIG. 1** is a block diagram illustrating a client/server-based ultrasound diagnostic system in accordance with the present invention.

[0013] Referring to **FIG. 1**, the client/server-based ultrasound diagnostic system **100** includes a server **10** and a plurality of clients **20A**, **20B**, **20C**, **20D** connected to the server **10**. The server **10** may receive and transmit data from/to the clients **20A**, **20B**, **20C**, **20D** via a network protocol such as TCP/IP, UDP/IP, ATM, etc. For example, the clients **20A**, **20B**, **20C**, **20D** may be arranged in an obstetrics department, a gynecology department, an internal treatment department, etc. of a hospital.

[0014] The server **10** includes a control unit **11**, a scan converter **12**, a memory unit **13** and an image processor **14**. The respective clients **20A**, **20B**, **20C**, **20D** include a probe **21**, a beam former **22** and a display unit **23**.

[0015] The probe **21** includes a transducer, a matching layer and a backing layer. The probe **21** may have one transducer or a linear transducer array that is comprised of a plurality of transducers (i.e., one-dimensional transducer

array). The transducer converts an electrical pulse signal into an ultrasound signal, as well as converting an ultrasound signal into an electrical pulse signal. The matching layer corrects a sound difference between a human body and an oscillator in the probe 21. The backing layer absorbs the sound energy of the oscillator to form an electrical pulse signal.

[0016] FIG. 2 is a block diagram illustrating a beam former of FIG. 1.

[0017] Referring to FIG. 2, the beam former 22, which is arranged in the clients 20A, 20B, 20C, 20D, comprises: a pulse signal generating unit 22a; a transmit beam forming unit 22b; a transmit beam amplifying unit 22c; a transmit/receive switch (Tx/Rx switch) 22d; a receive beam amplifying unit 22e; and a receive beam forming unit 22f.

[0018] Under the control of the control unit 11, which is arranged in the server 10, the pulse signal generating unit 22a generates a plurality of transmit pulse signals and then transmits those signals to the transmit beam forming unit 22b. The transmit beam forming unit 22b receives the plurality of transmit pulse signals and then forms a transmit pattern. That is, the transmit beam forming unit 22b may delay the respective transmit beam signals according to the control of the control unit 11 so as to form a transmit pattern. The transmit beam amplifying unit 22c amplifies the transmit pulse signals received from the transmit beam forming unit 22b. The Tx/Rx switch 22d transmits the amplified transmit pulse signals to the probe 21. The transducer or the transducer array arranged in the probe 21 converts the transmit pulse signals into an ultrasound signal. The ultrasound signal is then transmitted to the target object.

[0019] The transducer or the transducer array converts echo signals reflected from the target object into an electrical pulse signal. The Tx/Rx switch 22d and the receive beam amplifying unit 22e transmit the converted electrical pulse signal to the receive beam forming unit 22f. Considering that respective phases of the echo signals are different according to a distance between the target object and the transducer (or the transducer array), the receive beam forming unit 22f delays the respective electrical pulse signals to match the phases of the electrical pulse signals with one another. It then sums up the electrical pulse signals having the equal phase to form a receive beam. An analog/digital converter 24 converts the receive beam into a digital receive signal and then transmits the digital receive signal to the server 10.

[0020] The digital scan converter 12, which is arranged in the server 10, receives the digital receive signal, sequentially scans an image corresponding to the location of the transducer or the transducer array, and stores image data into the memory unit 13. According to the control of the control unit 11, the digital scan converter 13 reads the image data stored in the memory unit 13 to transmit the read image data into the image processor 14. The image processor 14 processes

the image data transmitted from the digital scan converter 12, generates an ultrasound image signal, and transmits the ultrasound image signal to the display unit 22 arranged in the clients 20A, 20B, 20C, 20D.

[0021] While the present invention has been described and illustrated with respect to a preferred embodiment of the invention, it will be apparent to those skilled in the art that variations and modifications are possible without deviating from the broad principles and teachings of the present invention which should be limited solely by the scope of the claims appended hereto.

What is claimed is:

1. A client/server-based ultrasound diagnostic system, comprising:

at least one client comprising a probe for transducing an electric signal into an ultrasound signal, and vice versa, a beam former for transceiving the electric signal from/to the probe, and a display unit; and

a server for controlling the probe and the beam former, generating an ultrasound image signal based on the electric signal received from the client, and transmitting the generated ultrasound image signal to the display unit.

2. A client/server-based ultrasound diagnostic system, comprising:

at least one client configured to comprise,

a probe for transducing an electric pulse signal into an ultrasound signal, and vice versa;

a beam former which comprises a pulse signal generating unit for generating a plurality of electric pulse signals, a transmit beam forming unit for forming a transmit beam by delaying the electric pulse signals received from the pulse signal generating unit, and a receive beam forming unit for forming a receive beam by delaying the electric pulse signals received from the probe;

an analog/digital converter for converting the receive beam into a digital receive signal; and

a display unit, and

a server configured to comprise,

a digital scan converter for forming image data based on the digital receive signal received from the analog/digital converter; and

an image processor for processing the image data received from the digital scan converter for transmission of the processed image data to the display unit.

\* \* \* \* \*

专利名称(译)	基于客户/服务器的超声诊断系统		
公开(公告)号	<a href="#">US20060173315A1</a>	公开(公告)日	2006-08-03
申请号	US11/223122	申请日	2005-09-12
申请(专利权)人(译)	MEDISON CO. , LTD.		
当前申请(专利权)人(译)	MEDISON CO. , LTD.		
[标]发明人	HYUN DONG GYU		
发明人	HYUN, DONG GYU		
IPC分类号	A61B8/00		
CPC分类号	A61B8/00 A61B8/565		
优先权	1020050001681 2005-01-07 KR		
外部链接	<a href="#">Espacenet</a> <a href="#">USPTO</a>		

摘要(译)

基于客户端/服务器的超声诊断系统技术领域基于客户端/服务器的超声诊断系统包括：客户端，被配置为包括用于将电信号转换为超声信号的探头，反之亦然，用于从/向探头收发电信号的波束形成器，以及显示单元；服务器，被配置为包括用于控制探头和波束形成器的控制单元，以及用于基于从客户端接收的电信号生成超声图像信号的图像处理，用于将所生成的超声图像信号发送到显示单元。

