



US009968332B2

(12) **United States Patent**
Tsuruno

(10) **Patent No.:** **US 9,968,332 B2**
(45) **Date of Patent:** ***May 15, 2018**

(54) **ULTRASONIC TRANSDUCER, ULTRASONIC PROBE, DIAGNOSTIC DEVICE, AND ELECTRONIC INSTRUMENT**

(71) Applicant: **SEIKO EPSON CORPORATION,** Tokyo (JP)

(72) Inventor: **Jiro Tsuruno,** Nagano (JP)

(73) Assignee: **Seiko Epson Corporation,** Tokyo (JP)

(*) Notice: Subject to any disclaimer, the term of this patent is extended or adjusted under 35 U.S.C. 154(b) by 0 days. days.

This patent is subject to a terminal disclaimer.

(21) Appl. No.: **15/268,918**

(22) Filed: **Sep. 19, 2016**

(65) **Prior Publication Data**

US 2017/0000460 A1 Jan. 5, 2017

Related U.S. Application Data

(63) Continuation of application No. 13/896,719, filed on May 17, 2013, now Pat. No. 9,474,508.

(30) **Foreign Application Priority Data**

May 21, 2012 (JP) 2012-115321

(51) **Int. Cl.**

A61B 8/00 (2006.01)

B06B 1/06 (2006.01)

(52) **U.S. Cl.**

CPC **A61B 8/4494** (2013.01); **B06B 1/0607** (2013.01); **B06B 1/0629** (2013.01)

(58) **Field of Classification Search**

CPC H01L 41/09; H01L 41/22; G01N 29/34; G01N 29/00; A61B 8/4455; A61B 8/44;

(Continued)

(56) **References Cited**

U.S. PATENT DOCUMENTS

5,761,156 A 6/1998 Reuter et al.
6,984,922 B1 1/2006 Nagahara et al.
(Continued)

FOREIGN PATENT DOCUMENTS

JP 52-150615 A 12/1977
JP 60-260848 A 12/1985
(Continued)

OTHER PUBLICATIONS

The Extended European Search Report for the corresponding European Application No. 13168240.3 dated Jan. 2, 2017.

Primary Examiner — Long V Le

Assistant Examiner — Katherine McDonald

(57) **ABSTRACT**

An ultrasonic transducer includes “m” first ultrasonic elements including first diaphragms, and “n” second ultrasonic elements including second diaphragms. “m” represents a number of the first ultrasonic elements and is an integer of 1 or more. Each of the first diaphragms has a first area. “n” second ultrasonic elements includes second diaphragms. Each of the “n” second diaphragms has a second area being smaller than the first area. “n” represents a number of the second ultrasonic elements and is an integer larger than “m”. The “m” first ultrasonic elements are electrically connected in series in a case where “m” is an integer of 2 or more. The “n” second ultrasonic elements are electrically connected in series. B/A is within a range of 0.9 to 1.1, when a total sum of the first areas is “A” and a total sum of the second areas is “B”.

10 Claims, 6 Drawing Sheets

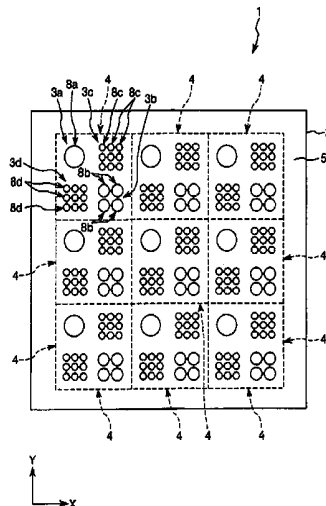

(58) **Field of Classification Search**

CPC G01S 7/52079; G01S 3/80; B06B 1/00;
B06B 2201/20

See application file for complete search history.

(56) **References Cited**

U.S. PATENT DOCUMENTS

7,779,696	B2	8/2010	Huang
2008/0013405	A1	1/2008	Moon et al.
2008/0089181	A1	4/2008	Adachi et al.
2010/0327695	A1	12/2010	Goel et al.
2011/0319766	A1	12/2011	Tsuruno
2011/0319767	A1	12/2011	Tsuruno

FOREIGN PATENT DOCUMENTS

JP	2003-169800	A	6/2003
JP	2003-339700	A	12/2003
JP	2004-072755	A	3/2004
JP	2005-253751	A	9/2005
JP	2006-075425	A	3/2006
JP	2012-005689	A	1/2012
JP	2012-005690	A	1/2012
WO	2009/088307	A1	7/2009

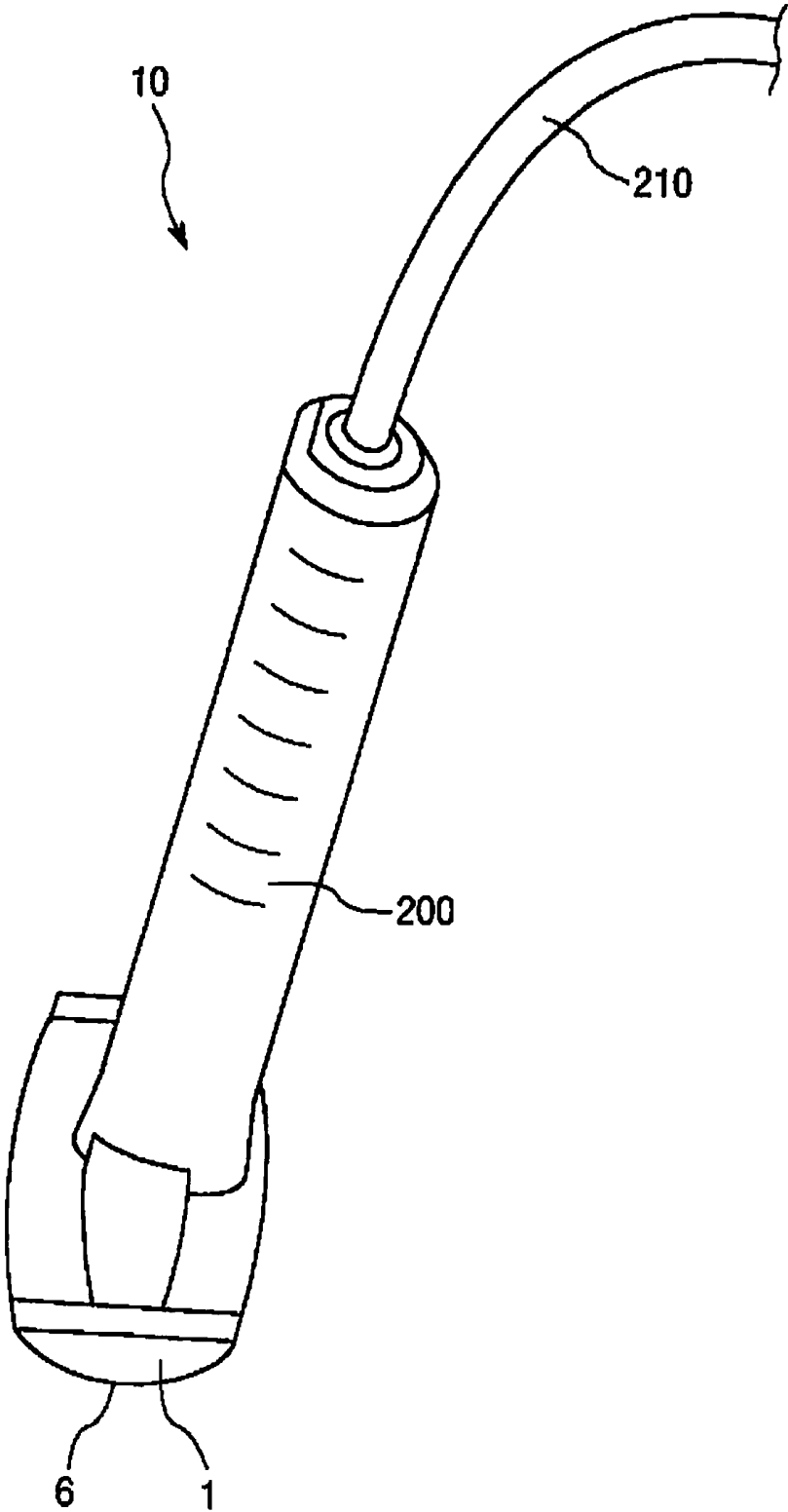

Fig. 1

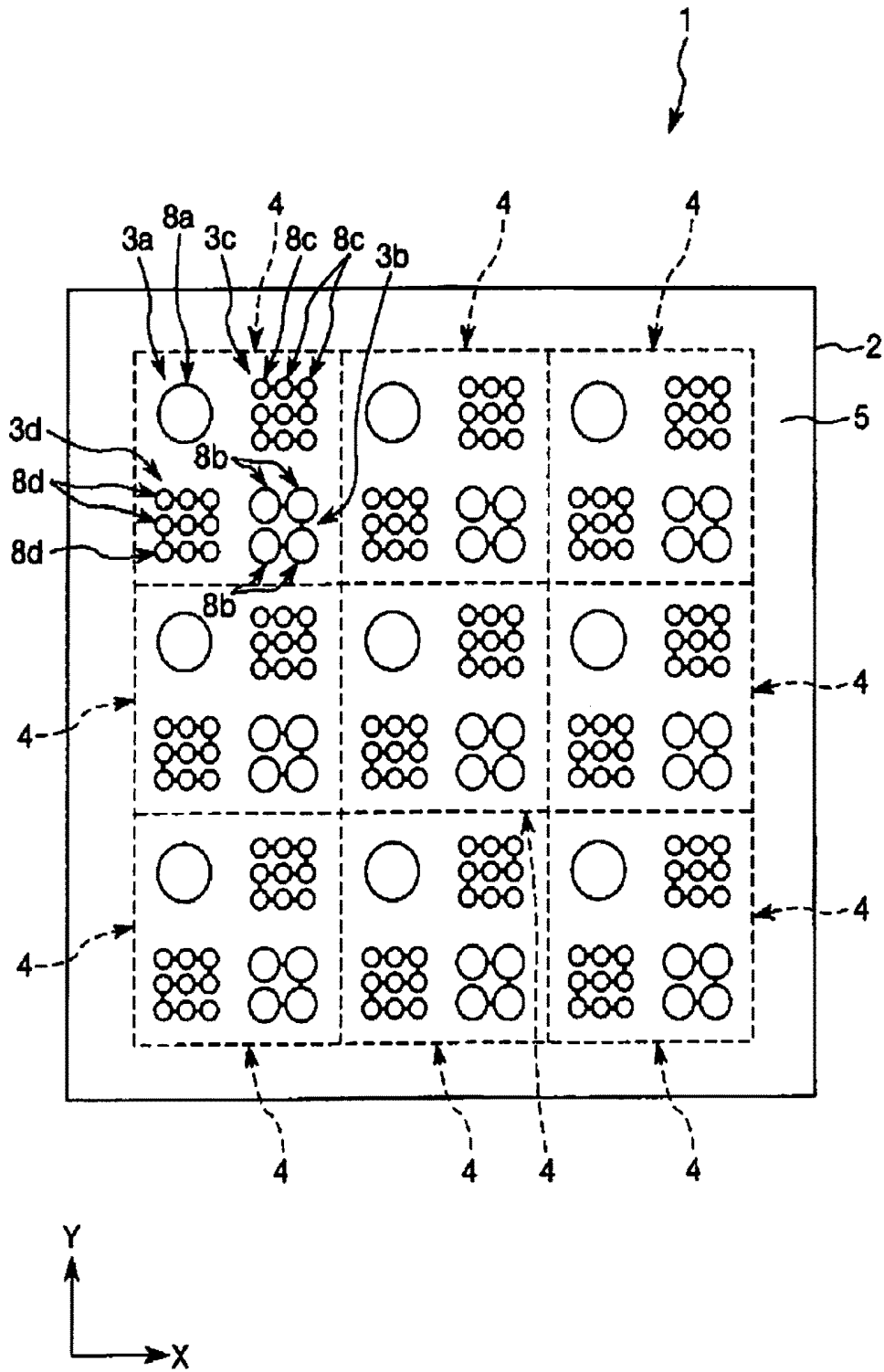

Fig. 2

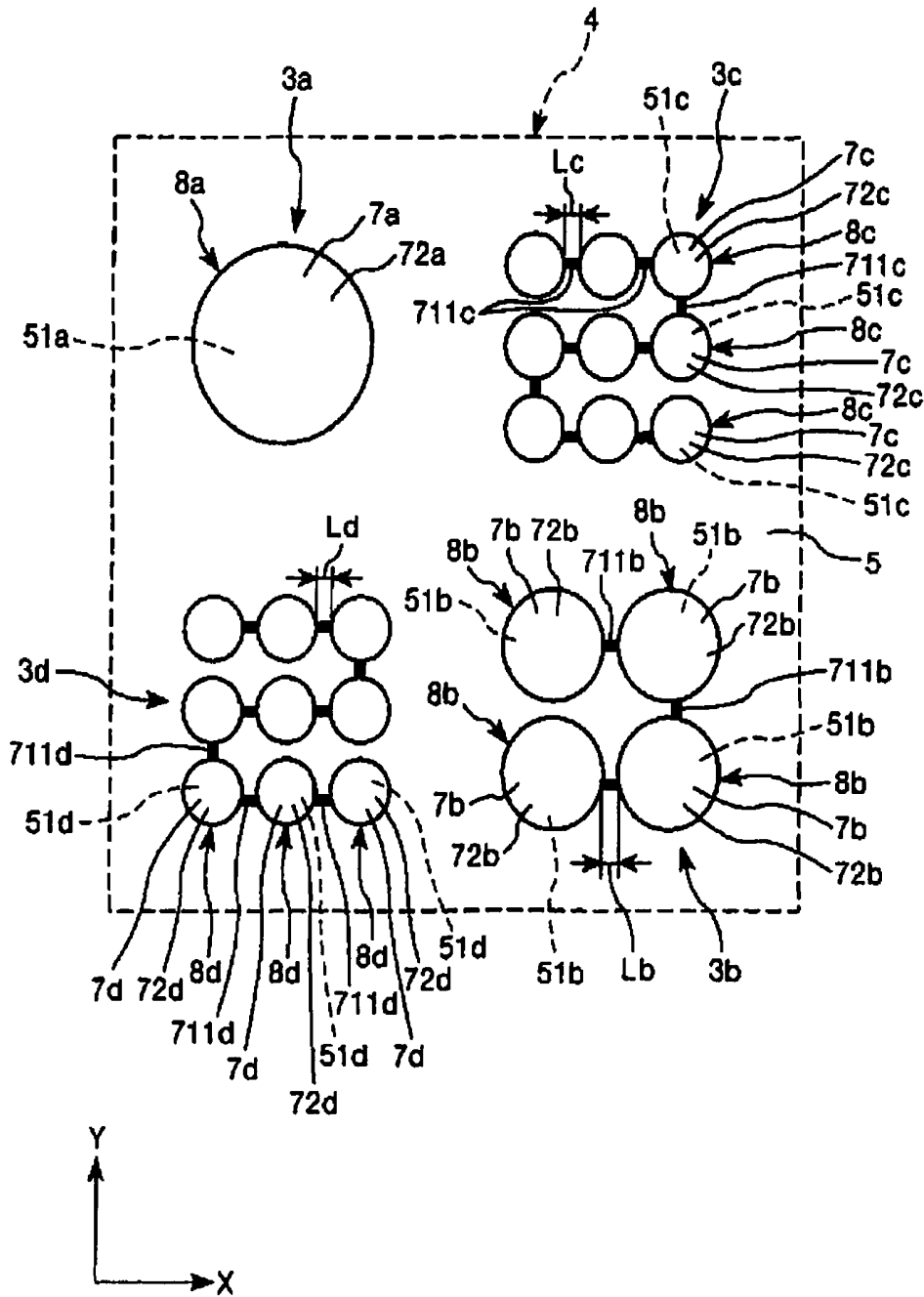

Fig. 3

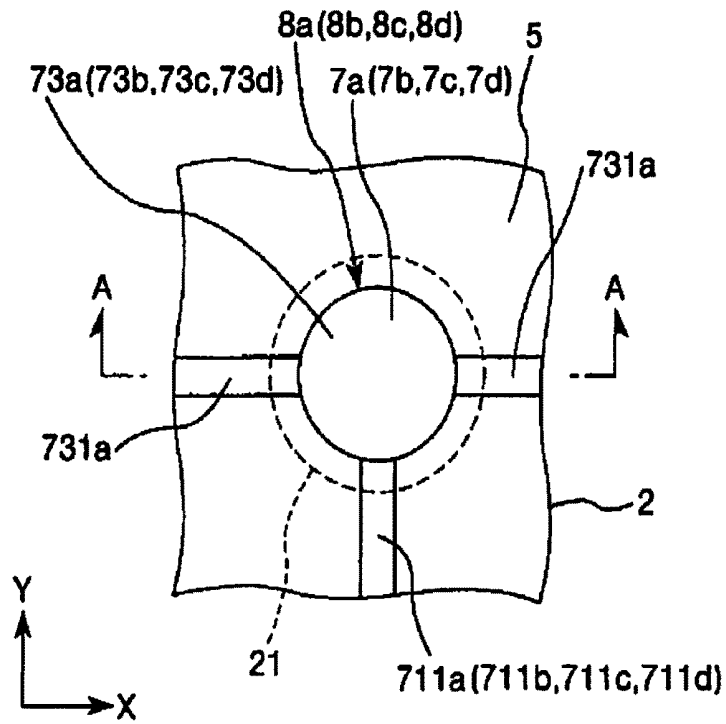

Fig. 4

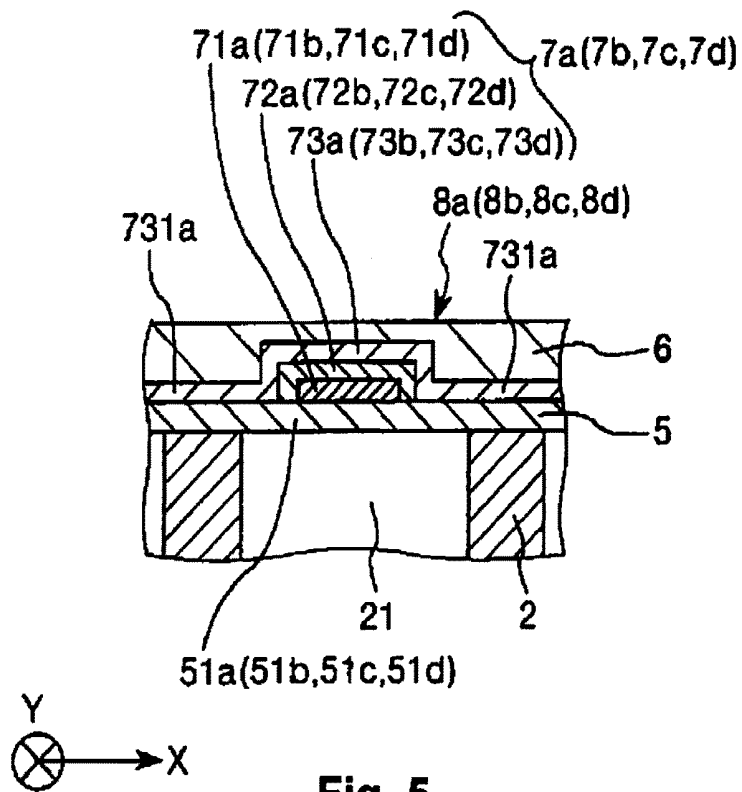

Fig. 5

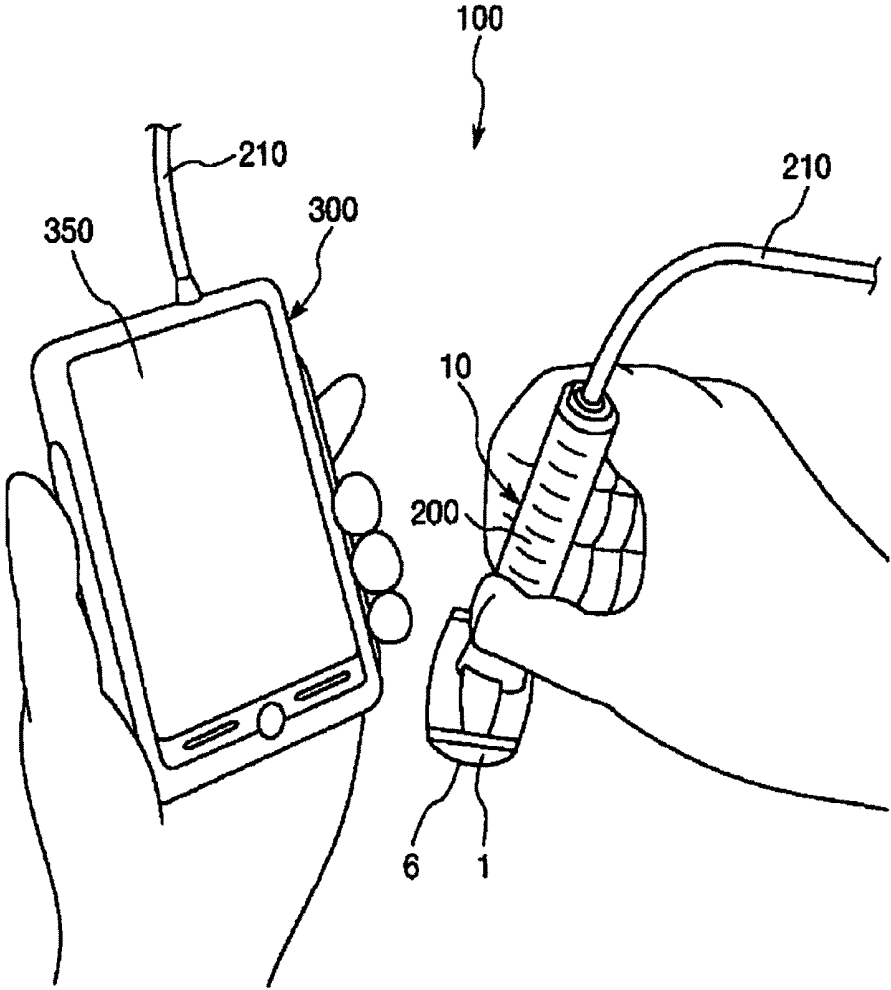

Fig. 6

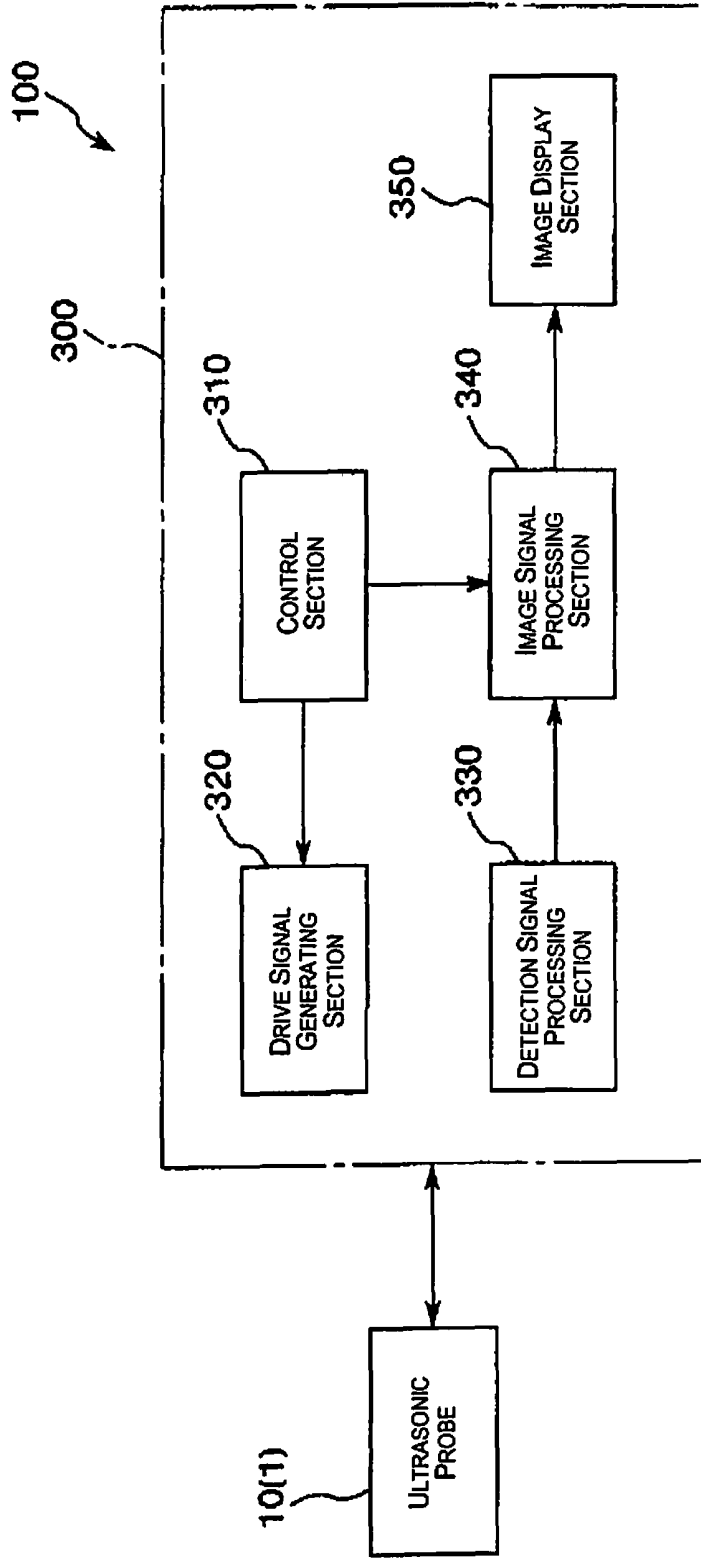

Fig. 7

ULTRASONIC TRANSDUCER, ULTRASONIC PROBE, DIAGNOSTIC DEVICE, AND ELECTRONIC INSTRUMENT

CROSS-REFERENCE TO RELATED APPLICATIONS

This application is a continuation application of U.S. patent application Ser. No. 13/896,719, filed on May 17, 2013. This application claims priority to Japanese Patent Application No. 2012-115321 filed on May 21, 2012. The entire disclosures of U.S. patent application Ser. No. 13/896,719 and Japanese Patent Application No. 2012-115321 are expressly incorporated by reference herein.

BACKGROUND

Technical Field

The present invention relates to an ultrasonic transducer, an ultrasonic probe, a diagnostic device, and an electronic instrument.

Background Technology

An ultrasonic transducer in which a plurality of ultrasonic elements are arranged in a matrix pattern has been known. This ultrasonic transducer includes a substrate that has a plurality of openings, a supporting film that is provided on the substrate so as to cover each of the openings, and a piezoelectric element that is provided on a part of the supporting film corresponding to each of the openings. A diaphragm is constructed by the part of the supporting film corresponding to the opening which is a part coinciding with the opening of the supporting film in a planar view. The ultrasonic element is constructed by the diaphragm and the piezoelectric element provided on the diaphragm.

In this ultrasonic transducer, it has been known that two kinds of ultrasonic elements in which the areas of the diaphragms are different are provided, and are driven at different frequencies (for example, see Patent Document 1). In Patent Document 1, it is considered that the plurality of ultrasonic elements having the larger areas of the diaphragms are electrically connected in parallel with respect to each other. Likewise, it is considered that the plurality of ultrasonic elements having the smaller areas of the diaphragms are electrically connected in parallel with respect to each other.

When the two kinds of ultrasonic elements are compared, since the ultrasonic elements having the larger areas of the diaphragms have low resonance frequency, they are driven at low frequency and generate ultrasonic waves of low frequency. Also, since the ultrasonic elements having the smaller areas of the diaphragms have high resonance frequency, they are driven at high frequency and generate ultrasonic waves of high frequency. In a diagnostic device having an ultrasonic probe that uses this ultrasonic transducer, when a deep part (long distance) of a living body as a test target is diagnosed, ultrasonic waves of low frequency are used for diagnosis because ultrasonic waves of high frequency cannot reach a deep part. On the other hand, when a shallow part (short distance) of a living body is diagnosed, ultrasonic waves of high frequency are used for diagnosis so as to increase the resolution.

However, the sensitivity of an ultrasonic element becomes high as the area of the diaphragm becomes large. Therefore, the well-known ultrasonic transducer has a problem that the sensitivity of the ultrasonic elements having the smaller areas of the diaphragms is lower than that of the ultrasonic elements having the larger areas of the diaphragms. Further,

due to the difference in the sensitivity, there is a problem that the magnitude of a signal output from each ultrasonic element is different, and a circuit configuration becomes complicated in order to match the magnitude of the signal.

Japanese Laid-open Patent Publication No. 2006-75425 (Patent Document 1) is an example of the related art.

SUMMARY

Problems to be Solved by the Invention

The advantage of the invention is to provide an ultrasonic transducer, an ultrasonic probe, a diagnostic device, and an electronic instrument in which the difference in the sensitivity between two kinds of ultrasonic element groups is reduced, ultrasonic waves of a plurality of frequencies can be transmitted and received, and also the circuit configuration can be simplified.

Means Used to Solve the Above-Mentioned Problems

This advantage is achieved by the invention described below. According to one aspect of the invention, an ultrasonic transducer of the invention includes “m” first ultrasonic elements and “n” second ultrasonic elements. The “m” first ultrasonic elements includes first diaphragms. The “m” first ultrasonic elements are configured and arranged to transmit and receive ultrasonic waves, where “m” represents a number of the first ultrasonic elements and is an integer of 1 or more. Each of the first diaphragms having a first area. The “n” second ultrasonic elements include second diaphragms. Each of the “n” second diaphragms has a second area being smaller than the first area. The “n” second ultrasonic elements are configured and arranged to transmit and receive the ultrasonic waves, where “n” represents a number of the second ultrasonic elements and is an integer larger than “m”. The “m” first ultrasonic elements are electrically connected in series in a case where “m” is an integer of 2 or more. The “n” second ultrasonic elements are electrically connected in series. B/A is within a range of 0.9 to 1.1, when a total sum of the first areas is “A” and a total sum of the second areas is “B”.

BRIEF DESCRIPTION OF THE DRAWINGS

Referring now to the attached drawings which form a part of this original disclosure:

FIG. 1 is a perspective view showing an embodiment of an ultrasonic probe according to the invention;

FIG. 2 is a plan view showing an ultrasonic transducer of the ultrasonic probe shown in FIG. 1;

FIG. 3 is a plan view showing a cell unit of the ultrasonic transducer shown in FIG. 2;

FIG. 4 is a plan view enlarging a part of the ultrasonic transducer shown in FIG. 2;

FIG. 5 is a sectional view along line A-A of FIG. 4;

FIG. 6 is a perspective view showing an embodiment of a diagnostic device according to the invention; and

FIG. 7 is a block diagram showing the embodiment of the diagnostic device according to the invention.

DETAILED DESCRIPTION OF EXEMPLARY EMBODIMENTS

Hereinafter, the ultrasonic transducer, the ultrasonic probe, the diagnostic device, and the electronic instrument

of the invention will be explained in detail based on a preferred embodiment shown in the attached drawings.

Embodiment of Ultrasonic Transducer and Ultrasonic Probe

FIG. 1 is a perspective view showing an embodiment of the ultrasonic probe according to the invention. FIG. 2 is a plan view showing the ultrasonic transducer of the ultrasonic probe shown in FIG. 1. FIG. 3 is a plan view showing a cell unit of the ultrasonic transducer shown in FIG. 2. FIG. 4 is a plan view enlarging a part of the ultrasonic transducer shown in FIG. 2. FIG. 5 is a sectional view along line A-A of FIG. 4.

Hereinafter, explanations will be made by describing the upper side in FIG. 2-FIG. 5 as "upper", the lower side as "lower", the right side as "right", and the left side as "left". In FIG. 2 and FIG. 3, illustrations of parts and the like of an acoustic matching section, an upper electrode, a lower electrode, a conducting wire for an upper electrode, and a conducting wire for a lower electrode are omitted, and the ultrasonic transducer is schematically illustrated. Further, in FIG. 2 and FIG. 3, the outline of the cell unit is shown by a broken line. In FIG. 4, an illustration of the acoustic matching section is omitted. Also, as shown in each drawing, an X axis and a Y axis orthogonal to each other are assumed. An X axis direction corresponds to an azimuth direction, and a Y axis direction corresponds to a slice direction.

As shown in FIG. 1, an ultrasonic probe 10 has a case 200, and an ultrasonic transducer 1 that is housed (accommodated) in the case 200. The ultrasonic transducer 1 is disposed in a tip end portion (the lower side in the drawing) of the case 200. In such a case, a substrate 2, described below, of the ultrasonic transducer 1 is fixed to the case 200 directly or with a supporting member for supporting the substrate 2. The supporting member is not shown in the drawing. The ultrasonic probe 10 can be used as an ultrasonic probe for various kinds of diagnostic devices such as a diagnostic device 100 described below.

In the present embodiment, a surface of the ultrasonic transducer 1, that is, a surface of an acoustic matching section 6 is exposed outside. The acoustic matching section 6 serves as a protective layer of the ultrasonic probe 10 and the ultrasonic transducer 1. Although the constituent material of the acoustic matching section 6 is not limited to a specific one, a material that is substantially similar to a living body with respect to the acoustic impedance, such as silicone rubber, is used. Here, it may be configured such that the surface of the acoustic matching section 6 is not exposed outside.

In the present embodiment, the ultrasonic probe 10 is a contact type sensor that is used by bringing the surface of the acoustic matching section 6 into contact with (applying to) a living body as a test target. Specifically, in conducting a test, the ultrasonic probe 10 is used by applying the surface of the acoustic matching section 6 to a living body as a test target. In such a case, when ultrasonic waves are sent out from an ultrasonic element, described below, of the ultrasonic transducer 1 toward the acoustic matching section 6, the ultrasonic waves pass through the acoustic matching section 6 and propagate through the living body. Then, the ultrasonic waves reflected on a predetermined part inside the living body pass through the acoustic matching section 6 and are input to the ultrasonic element.

Also, the ultrasonic probe 10 is electrically connected with a device main body 300 (see FIG. 6 and FIG. 7), described below, of the diagnostic device 100 through a cable 210. As shown in FIG. 2-FIG. 5, the ultrasonic transducer 1 has the substrate 2, a plurality of (nine in the configuration shown in the drawing) cell units (ultrasonic

element units) 4 that are provided on the substrate 2 so as to transmit and receive ultrasonic waves, and the acoustic matching section 6 that is provided on the substrate 2 on the side of the cell units 4 so as to cover each of the cell units 4.

Although the shape of the substrate 2 is not limited to a specific one, it forms a quadrangle in a planar view (in a planar view seen from the thickness direction of the substrate 2) in the configuration shown in the drawing. Also, as another shape of the substrate 2 in a planar view, another polygon such as a pentagon or a hexagon, a circle, or an ellipse can be listed, for example. Although the constituent material of the substrate 2 is not limited to a specific one, a material for forming a semiconductor such as silicon (Si) is used, for example. Consequently, it can be processed easily by etching or the like. Each cell unit 4 is arranged on the substrate 2 in a matrix pattern, that is, in a two-dimensionally pattern with predetermined intervals. In other words, a plurality of (three in the configuration shown in the drawing) cell units 4 are arranged in parallel along the X axis direction, and a plurality of (three in the configuration shown in the drawing) cell units 4 are arranged in parallel along the Y axis direction.

The cell unit 4 has a first ultrasonic element group 3a provided with "m" first ultrasonic elements (first ultrasonic vibrators) 8a, with "m" representing the number of the first ultrasonic elements and being an integer of 1 or more (one in the configuration shown in the drawing), that have first diaphragms 51a, and transmit and receive ultrasonic waves, a second ultrasonic element group 3b provided with "n" second ultrasonic elements (second ultrasonic vibrators) 8b, with "n" representing the number of the second ultrasonic elements and being an integer larger than "m" (four in the configuration shown in the drawing), that have second diaphragms 51b whose areas (areas in a planar view) are smaller than those of the first diaphragms 51a, and transmit and receive ultrasonic waves, and two third ultrasonic element groups 3c and 3d provided with "k" third ultrasonic elements (third ultrasonic vibrators) 8c, 8d, with "k" representing the number of the third ultrasonic elements and being an integer larger than "m" (nine in the configuration shown in the drawing), that have third diaphragms 51c and 51d whose areas (areas in a planar view) are smaller than those of the second diaphragms 51b, respectively, and transmit and receive ultrasonic waves. However, the number of the third ultrasonic element groups may be one.

Hereinafter, the first ultrasonic element group 3a, the second ultrasonic element group 3b, and the third ultrasonic element groups 3c and 3d are also referred to as "ultrasonic element group", respectively. Further, the first ultrasonic element 8a, the second ultrasonic element 8b, and the third ultrasonic elements 8c and 8d are also referred to as "ultrasonic element", respectively. Further, the first diaphragm 51a, the second diaphragm 51b, and the third diaphragms 51c and 51d are also referred to as "diaphragm", respectively.

The first ultrasonic element group 3a is disposed at the upper left, the second ultrasonic element group 3b is disposed at the lower right, the third ultrasonic element group 3c is disposed at the upper right, and the third ultrasonic element group 3d is disposed at the lower left, respectively. However, needless to say, the invention is not limited to this arrangement. Here, explanations will be made on the first ultrasonic element 8a, the second ultrasonic element 8b, and the third ultrasonic elements 8c and 8d. However, these ultrasonic elements 8a, 8b, 8c, and 8d have similar basic configurations although the sizes are different. Hereinafter,

therefore, explanations will be made on the first ultrasonic element **8a** as a representative. In FIG. 4 and FIG. 5, for the second ultrasonic element group **3b** and the third ultrasonic element groups **3c** and **3d**, each section thereof that corresponds to each section of the first ultrasonic element group **3a** is shown with a reference symbol “b”, “c” or “d” instead of “a” at the end thereof with parenthesis.

As shown in FIG. 4 and FIG. 5, the first ultrasonic element **8a** is constructed by the first diaphragm **51a** and a piezoelectric body (piezoelectric element) **7a**. The first ultrasonic element **8a** is formed on the substrate **2**. Although the shape of the piezoelectric body **7a** is not limited to a specific one, it forms a circle in a planar view in the configuration shown in the drawing. Also, as another shape of the piezoelectric body **7a** in a planar view, a quadrangle (square, rectangle), a polygon such as a pentagon or a hexagon, or an ellipse can be listed, for example. Incidentally, the piezoelectric body **7a** and the wiring thereof will be described below. An opening **21** for forming the first diaphragm **51a** of the first ultrasonic element **8a** is formed in a part of the substrate **2** corresponding to each of the first ultrasonic element **8a**. Although the shape of the opening **21** is not limited to a specific one, it forms a circle in a planar view in the configuration shown in the drawing. Also, as another shape of the opening **21** in a planar view, a quadrangle (square, rectangle), a polygon such as a pentagon or a hexagon, or an ellipse can be listed, for example.

A supporting film **5** is formed on the substrate **2**, and each of the openings **21** is covered with the supporting film **5**. The first diaphragm **51a** is constructed by a part of the supporting film **5** corresponding to the opening which is a part (region) covering the opening **21**, that is, a part coinciding with (part overlapping with) the opening **21** of the supporting film **5** in a planar view. The piezoelectric body **7a** is provided on the first diaphragm **51a**.

Although the constituent material of the supporting film **5** is not limited to a specific one, the supporting film **5** is constructed by a layered body (two-layer structure) of an SiO₂ layer and a ZrO₂ layer, or an SiO₂ layer, for example. In a case where the substrate **2** is an Si substrate, the SiO₂ layer can be formed by conducting a thermal oxidation treatment to the surface of the substrate **2**. The ZrO₂ layer can be formed on the SiO₂ layer, for example, by a technique such as sputtering. Here, the ZrO₂ layer is a layer for preventing Pb that constitutes PZT from diffusing into the SiO₂ layer when PZT is used as a piezoelectric film **72a** of the piezoelectric body **7a**, for example. The piezoelectric film **72a** of the piezoelectric body **7a** will be described below. The ZrO₂ layer also has an effect such as an effect of improving deflection efficiency with respect to deformation of the piezoelectric film **72a**.

As shown in FIG. 5, the piezoelectric body **7a** has a lower electrode **71a** formed on the first diaphragm **51a** (the supporting film **5**), the piezoelectric film **72a** formed on the lower electrode **71a**, and an upper electrode **73a** formed on the piezoelectric film **72a**. Also, a conducting wire (wiring) for a lower electrode **711a** is connected with the lower electrode **71a**, and the conducting wire for a lower electrode **711a** extends along the Y axis direction on the supporting film **5** as shown in FIG. 4, for example. The conducting wire for a lower electrode **711a** is electrically connected with the cable **210** via a through-hole formed in the supporting film **5** and the substrate **2**. The through-hole is not shown in the drawing. With this configuration, the first ultrasonic element **8a** (the first ultrasonic element group **3a**) can be driven

independently. Likewise, the second ultrasonic element group **3b** and the third ultrasonic element groups **3c** and **3d** can be driven independently.

In the second ultrasonic element group **3b**, each second ultrasonic element **8b** is electrically connected in series by a conducting wire for a lower electrode **711b**. In this case, the conducting wire for a lower electrode **711b** is interposed between lower electrodes **71b** of two adjacent second ultrasonic elements **8b**, and the lower electrodes **71b** of the two adjacent second ultrasonic elements **8b** are electrically connected by the conducting wire for a lower electrode **711b**.

Likewise, in the third ultrasonic element group **3c**, each third ultrasonic element **8c** is electrically connected in series by a conducting wire for a lower electrode **711c**. In this case, the conducting wire for a lower electrode **711c** is interposed between lower electrodes **71c** of two adjacent third ultrasonic elements **8c**, and the lower electrodes **71c** of the two adjacent third ultrasonic elements **8c** are electrically connected by the conducting wire for a lower electrode **711c**.

Likewise, in the third ultrasonic element group **3d**, each third ultrasonic element **8d** is electrically connected in series by a conducting wire for a lower electrode **711d**. In this case, the conducting wire for a lower electrode **711d** is interposed between lower electrodes **71d** of two adjacent third ultrasonic elements **8d**, and the lower electrodes **71d** of the two adjacent third ultrasonic elements **8d** are electrically connected by the conducting wire for a lower electrode **711d**.

As shown in FIG. 4 and FIG. 5, for example, a conducting wire (wiring) for an upper electrode **731a** is connected with the upper electrodes **73a**, **73b**, **73c** and **73d**, and the conducting wire for an upper electrode **731a** extends along the X axis direction on the supporting film **5**. The conducting wire for an upper electrode **731a** serves as a common conducting wire of each first ultrasonic element **8a** (the first ultrasonic element group **3a**), the second ultrasonic element group **3b**, the third ultrasonic element group **3c**, and the third ultrasonic element group **3d** arranged in the X axis direction, and is connected to the GND, for example, at the end portion thereof. In this manner, the upper electrodes **73a**, **73b**, **73c** and **73d** of the ultrasonic element **8a**, **8b**, **8c** and **8d** are earthed. Alternatively, contrary to the above, the conducting wires for a lower electrode **711a**, **711b**, **711c**, and **711d** may be connected to the GND.

The constituent materials of the lower electrode **71a**, the upper electrode **73a**, the conducting wire for a lower electrode **711a**, and the conducting wire for an upper electrode **731a** are not limited to specific ones as long as they have conductive properties, respectively. For example, various kinds of metal materials can be used. Also, the lower electrode **71a**, the upper electrode **73a**, the conducting wire for a lower electrode **711a**, and the conducting wire for an upper electrode **731a** may be single layers, respectively, or may be layered bodies in which a plurality of layers are laminated, respectively. As specific examples, for example, a Ti/Ir/Pt/Ti layered film can be used as the lower electrode **71a** and the conducting wire for a lower electrode **711a**, respectively, and an Ir film can be used as the upper electrode **73a** and the conducting wire for an upper electrode **731a**, respectively.

The piezoelectric film **72a** is made by forming PZT (lead zirconate titanate) into a film shape, for example. In the present embodiment, PZT is used as the piezoelectric film **72a**. However, any material can be used as long as it is a material that can contract (expand or contract) in an in-plane direction by applying a voltage thereto. For example, lead

titanate (PbTiO₃), lead zirconate (PbZrO₃), lead lanthanum titanate ((Pb, La) TiO₃), or the like can be used as well as PZT.

In the first ultrasonic element **8a**, for example, when a voltage is applied between the lower electrode **71a** and the upper electrode **73a** by the device main body **300** (see FIG. 6, FIG. 7) through the cable **210**, the piezoelectric film **72a** expands or contracts in the in-plane direction. In this instance, a surface of the piezoelectric film **72a** is attached to the supporting film **5** through the lower electrode **71a**, and the upper electrode **73a** is formed on the other surface thereof. Here, since any other layer is not formed on the upper electrode **73a**, the supporting film **5** side of the piezoelectric film **72a** does not easily expand or contract, while the upper electrode **73a** side of the piezoelectric film **72a** easily expands or contracts. Therefore, when a voltage is applied to the piezoelectric film **72a**, deflection that causes projection occurs on the opening **21** side, which results in deflection of the first diaphragm **51a**. Consequently, when an alternating voltage is applied to the piezoelectric film **72a**, the first diaphragm **51a** vibrates with respect to the film thickness direction, and this vibration of the first diaphragm **51a** transmits (sends) ultrasonic waves.

In transmission of such ultrasonic waves, an alternating voltage, whose frequency is equal to the resonance frequency of the first ultrasonic element **8a**, or is close to the resonance frequency and is smaller than the resonance frequency, is applied to the piezoelectric film **72a**, and the first ultrasonic element **8a** is resonantly driven. With this, the first diaphragm **51a** is greatly deflected, so that ultrasonic waves can be transmitted with high output. Preferably, in this case, the frequency of the alternating voltage applied to the first ultrasonic element **8a** is between 0.5 times and 0.9 times with respect to the resonance frequency of the first ultrasonic element **8a**. If the frequency of the alternating voltage is less than 0.5 times with respect to the resonance frequency of the first ultrasonic element **8a**, the output of the transmitted ultrasonic waves will become small and the waveform of the ultrasonic waves will easily be disturbed depending on other conditions. On the other hand, if the frequency of the alternating voltage is more than 0.9 times with respect to the resonance frequency of the first ultrasonic element **8a**, the first ultrasonic element **8a** will easily be damaged depending on other conditions.

In receiving ultrasonic waves with the first ultrasonic element **8a**, when ultrasonic waves are input to the first diaphragm **51a**, the first diaphragm **51a** vibrates with respect to the film thickness direction. In the first ultrasonic element **8a**, this vibration of the first diaphragm **51a** causes a potential difference between the surface of the piezoelectric film **72a** on the lower electrode **71a** side and the surface of the piezoelectric film **72a** on the upper electrode **73a**, and a reception signal (detection signal) (current) is output from the upper electrode **73a** and the lower electrode **71a** in response to the displacement amount of the piezoelectric film **72a**. This signal is transmitted to the device main body **300** (see FIG. 6, FIG. 7) through the cable **210**, and predetermined signal processing or the like is conducted based on the signal. Then, in the device main body **300**, an ultrasonic image (electronic image) is formed and displayed.

In the ultrasonic probe **10**, planar waves of ultrasonic waves can be transmitted in a desired direction by delaying and differentiating the timing of transmission of ultrasonic waves from each cell unit **4** arranged in parallel along the X axis direction. Here, when the area of the first diaphragm **51a** of the first ultrasonic element **8a** is "S1", the area of the second diaphragm **51b** of the second ultrasonic element **8b**

is "S2", and the area of the third diaphragms **51c**, **51d** of the third ultrasonic elements **8c**, **8d** is "S3", it is sufficient for them to satisfy $S1 > S2 > S3$. Preferably, however, $S2/S1$ is within the range of 0.2 to 0.8, and more preferably, $S2/S1$ is within the range of 0.3 to 0.6. Also, preferably, $S3/S1$ is within the range of 0.1 to 0.5, and more preferably, $S3/S1$ is within the range of 0.2 to 0.4.

Also, when the resonance frequency of the first ultrasonic element **8a** is "F1", the resonance frequency of the second ultrasonic element **8b** is "F2", and the resonance frequency of the third ultrasonic elements **8c**, **8d** is "F3" ($F1 < F2 < F3$), it is preferable to set S1, S2, and S3, respectively, such that F3 becomes the least common multiple of F1 and F2. The number of the second ultrasonic element **8b** of the second ultrasonic element group **3b** is greater than the number of the first ultrasonic element **8a** of the first ultrasonic element group **3a**. In the present embodiment, the second ultrasonic element group **3b** has three or more second ultrasonic elements **8b**, and more specifically, the second ultrasonic element group **3b** has four second ultrasonic elements **8b**.

The numbers of the third ultrasonic elements **8c**, **8d** of the third ultrasonic element groups **3c**, **3d** are greater than the number of the second ultrasonic element **8b** of the second ultrasonic element group **3b**, respectively. In the present embodiment, the third ultrasonic element groups **3c**, **3d** have four or more third ultrasonic elements **8c**, **8d**, and more specifically, the third ultrasonic element groups **3c**, **3d** have nine third ultrasonic elements **8c**, **8d**, respectively. Here, the number of the second ultrasonic element **8b** of the second ultrasonic element group **3b** is not limited to a specific one as long as it is greater than the number of the first ultrasonic element **8a** of the first ultrasonic element group **3a**. Preferably, however, the number of the second ultrasonic element **8b** of the second ultrasonic element group **3b** is between 4 and 6.

The numbers of the third ultrasonic elements **8c**, **8d** of the third ultrasonic element groups **3c**, **3d** are not limited to specific ones as long as they are greater than the number of the second ultrasonic element **8b** of the second ultrasonic element group **3b**, respectively. Preferably, however, the numbers of the third ultrasonic elements **8c**, **8d** of the third ultrasonic element groups **3c**, **3d** are between 5 to 10. When the total sum of the areas of the first diaphragms **51a** of the first ultrasonic element group **3a** is "A" and the total sum of the areas of the second diaphragms **51b** of the second ultrasonic element group **3b** is "B", B/A is within the range of 0.9 to 1.1. With this configuration, since the sensitivity of the first ultrasonic element **8a** depends on the area of the first diaphragm **51a**, the sensitivity of the first ultrasonic element group **3a** and the sensitivity of the second ultrasonic element group **3b** can be made substantially the same. Consequently, a circuit needed for matching the magnitude of a signal in a case where the sensitivity is different can be omitted, and thus the circuit configuration can be simplified.

Preferably, B/A is within the range of 0.95 to 1.05. In this case, since the difference between the noise level of the first ultrasonic element group **3a** and the noise level of the second ultrasonic element group **3b** is small, there is no need to conduct fine adjustment so as to compare each signal when displaying a tomographic image. Therefore, the circuit configuration can further be simplified. When the total sum of the areas of the third diaphragms **51c**, **51d** of the third ultrasonic element groups **3c**, **3d** is "C", C/A is within the range of 0.9 to 1.1. With this configuration, the sensitivity of the first ultrasonic element group **3a** and the sensitivity of the third ultrasonic element groups **3c**, **3d** can be made substantially the same. Consequently, a circuit needed for

matching the magnitude of a signal in a case where the sensitivity is different can be omitted, and thus the circuit configuration can be simplified.

Preferably, C/A is within the range of 0.95 to 1.05. In this case, since the difference between the noise level of the first ultrasonic element group **3a** and the noise level of the third ultrasonic element group **3c** is small, there is no need to conduct fine adjustment so as to compare each signal when displaying a tomographic image. Therefore, the circuit configuration can further be simplified. Also, preferably, the conducting wire for a lower electrode **711b** that is a wiring for electrically connecting each second ultrasonic element **8b** of the second ultrasonic element group **3b** in series is provided such that the total sum of distances L_b of the conducting wires for a lower electrode **711b** between two adjacent second ultrasonic elements **8b** which are electrically connected with each other becomes shortest. With this configuration, the voltage drop in the conducting wire for a lower electrode **711b** can be reduced.

In the present embodiment, each second ultrasonic element **8b** of the second ultrasonic element group **3b** is connected by the conducting wire for a lower electrode **711b** as shown in FIG. 3. This configuration meets the conditions that the total sum of the distances L_b is shortest. Likewise, preferably, the conducting wire for a lower electrode **711c** that is a wiring for electrically connecting each third ultrasonic element **8c** of the third ultrasonic element group **3c** in series is provided such that the total sum of distances L_c of the conducting wires for a lower electrode **711c** between two adjacent third ultrasonic elements **8c** which are electrically connected with each other becomes shortest. With this configuration, the voltage drop in the conducting wire for a lower electrode **711c** can be reduced.

In the present embodiment, each third ultrasonic element **8c** of the third ultrasonic element group **3c** is connected by the conducting wire for a lower electrode **711c** in a zigzag pattern as shown in FIG. 3. This configuration meets the conditions that the total sum of the distances L_c is shortest. Likewise, preferably, the conducting wire for a lower electrode **711d** that is a wiring for electrically connecting each third ultrasonic element **8d** of the third ultrasonic element group **3d** in series is provided such that the total sum of distances L_d of the conducting wires for a lower electrode **711d** between two adjacent third ultrasonic elements **8d** which are electrically connected with each other becomes shortest. With this configuration, the voltage drop in the conducting wire for a lower electrode **711d** can be reduced.

In the present embodiment, each third ultrasonic element **8d** of the third ultrasonic element group **3d** is connected by the conducting wire for a lower electrode **711d** in a zigzag pattern as shown in FIG. 3. This configuration meets the conditions that the total sum of the distances L_d is shortest. Here, as the pattern of the conducting wire for a lower electrode **711c**, **711d** that makes the total sum of the distances L_c or L_d shortest, a spiral pattern can be listed, for example, as well as the above pattern.

Preferably, in the conducting wire for a lower electrode **711b** that is a wiring for electrically connecting each second ultrasonic element **8b** of the second ultrasonic element group **3b** in series, all of the distances L_b of the conducting wires for a lower electrode **711b** between two adjacent second ultrasonic elements **8b** of the second ultrasonic element group **3b** which are electrically connected with each other are the same. With this configuration, the phase difference of ultrasonic waves between two adjacent second ultrasonic elements **8b** which are electrically connected with each other

can be made the same in the second ultrasonic element group **3b**, and thus designing can be conducted easily.

Likewise, preferably, in the conducting wire for a lower electrode **711c** that is a wiring for electrically connecting each third ultrasonic element **8c** of the third ultrasonic element group **3c** in series, all of the distances L_c of the conducting wires for a lower electrode **711c** between two adjacent third ultrasonic elements **8c** of the third ultrasonic element group **3c** which are electrically connected with each other are the same. With this configuration, the phase difference of ultrasonic waves between two adjacent third ultrasonic elements **8c** which are electrically connected with each other can be made the same in the third ultrasonic element group **3c**, and thus designing can be conducted easily.

Likewise, preferably, in the conducting wire for a lower electrode **711d** that is a wiring for electrically connecting each third ultrasonic element **8d** of the third ultrasonic element group **3d** in series, all of the distances L_d of the conducting wires for a lower electrode **711d** between two adjacent third ultrasonic elements **8d** of the third ultrasonic element group **3d** which are electrically connected with each other are the same. With this configuration, the phase difference of ultrasonic waves between two adjacent third ultrasonic elements **8d** which are electrically connected with each other can be made the same in the third ultrasonic element group **3d**, and thus designing can be conducted easily.

Also, preferably, the distance L_c and the distance L_d are the same. With this configuration, the phase difference of ultrasonic waves between two adjacent third ultrasonic elements **8c** of the third ultrasonic element group **3c** which are electrically connected with each other and the phase difference of ultrasonic waves between two adjacent third ultrasonic elements **8d** of the third ultrasonic element group **3d** which are electrically connected with each other can be made the same. Therefore, designing can be conducted easily.

Also, preferably, the distance L_b , the distance L_c , and the distance L_d are the same. With this configuration, the phase difference of ultrasonic waves between two adjacent second ultrasonic elements **8b** of the second ultrasonic element group **3b** which are electrically connected with each other, the phase difference of ultrasonic waves between two adjacent third ultrasonic elements **8c** of the third ultrasonic element group **3c** which are electrically connected with each other, and the phase difference of ultrasonic waves between two adjacent third ultrasonic elements **8d** of the third ultrasonic element group **3d** which are electrically connected with each other can be made the same. Therefore, designing can be conducted easily. Here, the above-described expression that "distances are the same" includes a case where the distances are almost the same and a case where the distances are substantially the same as well as a case where the distances are completely the same.

Next, explanations will be made on a usage example of a case where the ultrasonic probe **10** is applied to the diagnostic device **100** described below. In this case, the third ultrasonic element group **3d** is not used. In transmission of ultrasonic waves, any one of the first ultrasonic element group **3a**, the second ultrasonic element group **3b**, and the third ultrasonic element group **3c** is selected and used. In reception of ultrasonic waves, any one of the first ultrasonic element group **3a**, the second ultrasonic element group **3b**, and the third ultrasonic element group **3c** is selected and used. As a display mode, either one of a B (brightness) mode and a harmonic mode is used. Such a case will be explained.

However, the third ultrasonic element group **3d** may be used instead of the third ultrasonic element group **3c**. Further, both of the third ultrasonic element group **3c** and the third ultrasonic element group **3d** may be used. The B mode is a display mode which displays an image by changing the intensity of the received ultrasonic waves into brightness (by conducting brightness modulation).

When ultrasonic waves propagate through a living body, the waveform is deformed due to the difference in speed of the ultrasonic waves propagating the living body, which causes high harmonic components with respect to the transmitted ultrasonic waves. The harmonic mode is a display mode which displays an image by receiving the high harmonic components with respect to the transmitted ultrasonic waves. Normally, in the harmonic mode, second harmonic waves, having frequency of twice as much as fundamental waves which are ultrasonic waves to be transmitted or third harmonic waves having frequency of three times, are received. In a case of diagnosing a part of a long distance, the harmonic mode is not used because high harmonic waves are hardly generated. In the harmonic mode, since high harmonic waves are received, the sensitivity can be improved and good ultrasonic images can be obtained.

The resonance frequency of the first ultrasonic element group **3a** is 1.00 MHz, the resonance frequency of the second ultrasonic element group **3b** is 1.50 MHz, and the resonance frequencies of the third ultrasonic element groups **3c** and **3d** are 3.00 MHz, respectively. Incidentally, 0.5 times-0.9 times of the resonance frequency of the first ultrasonic element group **3a** is 0.50 MHz-0.90 MHz. 0.5 times-0.9 times of the resonance frequency of the second ultrasonic element group **3b** is 0.75 MHz-1.35 MHz. 0.5 times-0.9 times of the resonance frequencies of the third ultrasonic element groups **3c** and **3d** are 1.5 MHz-2.70 MHz, respectively.

In the following explanations, a long distance refers to a distance that is more than 200 mm and equal to or less than 300 mm. A middle distance refers to a distance that is more than 50 mm and equal to or less than 200 mm. A short distance refers to a distance that is equal to or less than 50 mm. In the ultrasonic probe **10**, ultrasonic waves can be transmitted and received at various frequencies by changing the combination of the ultrasonic element group that transmits ultrasonic waves and the ultrasonic element group that receives ultrasonic waves, and thus various ultrasonic images can be obtained by using ultrasonic waves of various frequencies. Therefore, the same ultrasonic probe **10** can be used for diagnosis of parts of a short distance, a middle distance, and a long distance, respectively, without replacing the ultrasonic probe **10**. Accordingly, a laborious process to an operator can be reduced.

When a part of a short distance is diagnosed, ultrasonic waves are transmitted by the third ultrasonic element group **3c** that can generate ultrasonic waves of high frequency, and ultrasonic waves are received by the same third ultrasonic element group **3c**, for example. Consequently, the resolution can be improved, and a good image of a part of a short distance can be obtained. Further, when a part of a long distance is diagnosed, ultrasonic waves are transmitted by the first ultrasonic element group **3a** or the second ultrasonic element group **3b**, and ultrasonic waves are received by the first ultrasonic element group **3a**, the second ultrasonic element group **3b**, or the third ultrasonic element group **3c**, for example. Consequently, a good image of a part of a long distance can be obtained. Further, when the harmonic mode is used, and ultrasonic waves are received by the second ultrasonic element group **3b** or the third ultrasonic element

group **3c**, for example, a good image of a part of a middle distance or a long distance can be obtained. Next, specific examples will be explained based on Table 1 shown below.

TABLE 1

	Trans- mitting ultrasonic element group	Receiving ultrasonic element group	Mode	Range	Trans- mission fre- quency (MHz)	Recep- tion fre- quency (MHz)
Config- uration 1	3a	3a	B mode	Long distance	0.60	0.60
Config- uration 2	3a	3a	B mode	Long distance	0.75	0.75
Config- uration 3	3a	3a	B mode	Middle distance	0.90	0.90
Config- uration 4	3a	3b	Harmonic	Long distance	0.60	1.20
Config- uration 5	3a	3b	Harmonic	Middle distance	0.75	1.50
Config- uration 6	3a	3c	Harmonic	Long distance	0.60	1.80
Config- uration 7	3b	3b	B mode	Middle distance	0.90	0.90
Config- uration 8	3b	3a	B mode	Middle distance	0.90	0.90
Config- uration 9	3b	3b	B mode	Middle distance	1.20	1.20
Config- uration 10	3b	3b	B mode	Middle distance	1.35	1.35
Config- uration 11	3b	3c	Harmonic	Long distance	1.20	2.40
Config- uration 12	3b	3c	Harmonic	Long distance	1.35	2.70
Config- uration 13	3b	3c	Harmonic	Long distance	1.00	3.00
Config- uration 14	3c	3c	B mode	Short distance	1.80	1.80
Config- uration 15	3c	3c	B mode	Short distance	2.40	2.40
Config- uration 16	3c	3c	B mode	Short distance	2.70	2.70

As shown in Table 1, in Configuration 1, the B mode is used, ultrasonic waves are transmitted by the first ultrasonic element group **3a**, and ultrasonic waves are received by the first ultrasonic element group **3a**. This configuration is used for diagnosis of a part of a long distance. The frequency of the transmitted ultrasonic waves is 0.60 MHz, for example, and the frequency of the received ultrasonic waves is 0.60 MHz, for example. In Configuration 2, the B mode is used, ultrasonic waves are transmitted by the first ultrasonic element group **3a**, and ultrasonic waves are received by the first ultrasonic element group **3a**. This configuration is used for diagnosis of a part of a long distance. The frequency of the transmitted ultrasonic waves is 0.75 MHz, for example, and the frequency of the received ultrasonic waves is 0.75 MHz, for example.

In Configuration 3, the B mode is used, ultrasonic waves are transmitted by the first ultrasonic element group **3a**, and

ultrasonic waves are received by the first ultrasonic element group **3a**. This configuration is used for diagnosis of a part of a middle distance. The frequency of the transmitted ultrasonic waves is 0.90 MHz, for example, and the frequency of the received ultrasonic waves is 0.90 MHz, for example. In Configuration 4, the harmonic mode is used, ultrasonic waves are transmitted by the first ultrasonic element group **3a**, and ultrasonic waves are received by the second ultrasonic element group **3b**. This configuration is used for diagnosis of a part of a long distance. The frequency of the transmitted ultrasonic waves is 0.60 MHz, for example, and the frequency of the received ultrasonic waves is 1.20 MHz, for example.

In Configuration 5, the harmonic mode is used, ultrasonic waves are transmitted by the first ultrasonic element group **3a**, and ultrasonic waves are received by the second ultrasonic element group **3b**. This configuration is used for diagnosis of a part of a middle distance. The frequency of the transmitted ultrasonic waves is 0.75 MHz, for example, and the frequency of the received ultrasonic waves is 1.50 MHz, for example. In Configuration 6, the harmonic mode is used, ultrasonic waves are transmitted by the first ultrasonic element group **3a**, and ultrasonic waves are received by the third ultrasonic element group **3c**. This configuration is used for diagnosis of a part of a long distance. The frequency of the transmitted ultrasonic waves is 0.60 MHz, for example, and the frequency of the received ultrasonic waves is 1.80 MHz, for example.

In Configuration 7, the B mode is used, ultrasonic waves are transmitted by the second ultrasonic element group **3b**, and ultrasonic waves are received by the second ultrasonic element group **3b**. This configuration is used for diagnosis of a part of a middle distance. The frequency of the transmitted ultrasonic waves is 0.90 MHz, for example, and the frequency of the received ultrasonic waves is 0.90 MHz, for example. In Configuration 8, the B mode is used, ultrasonic waves are transmitted by the second ultrasonic element group **3b**, and ultrasonic waves are received by the first ultrasonic element group **3a**. This configuration is used for diagnosis of a part of a middle distance. The frequency of the transmitted ultrasonic waves is 0.90 MHz, for example, and the frequency of the received ultrasonic waves is 0.90 MHz, for example.

In Configuration 9, the B mode is used, ultrasonic waves are transmitted by the second ultrasonic element group **3b**, and ultrasonic waves are received by the second ultrasonic element group **3b**. This configuration is used for diagnosis of a part of a middle distance. The frequency of the transmitted ultrasonic waves is 1.20 MHz, for example, and the frequency of the received ultrasonic waves is 1.20 MHz, for example. In Configuration 10, the B mode is used, ultrasonic waves are transmitted by the second ultrasonic element group **3b**, and ultrasonic waves are received by the second ultrasonic element group **3b**. This configuration is used for diagnosis of a part of a middle distance. The frequency of the transmitted ultrasonic waves is 1.35 MHz, for example, and the frequency of the received ultrasonic waves is 1.35 MHz, for example.

In Configuration 11, the harmonic mode is used, ultrasonic waves are transmitted by the second ultrasonic element group **3b**, and ultrasonic waves are received by the third ultrasonic element group **3c**. This configuration is used for diagnosis of a part of a long distance. The frequency of the transmitted ultrasonic waves is 1.20 MHz, for example, and the frequency of the received ultrasonic waves is 2.40 MHz, for example. In Configuration 12, the harmonic mode is used, ultrasonic waves are transmitted by the second

ultrasonic element group **3b**, and ultrasonic waves are received by the third ultrasonic element group **3c**. This configuration is used for diagnosis of a part of a long distance. The frequency of the transmitted ultrasonic waves is 1.35 MHz, for example, and the frequency of the received ultrasonic waves is 2.70 MHz, for example.

In Configuration 13, the harmonic mode is used, ultrasonic waves are transmitted by the second ultrasonic element group **3b**, and ultrasonic waves are received by the third ultrasonic element group **3c**. This configuration is used for diagnosis of a part of a long distance. The frequency of the transmitted ultrasonic waves is 1.00 MHz, for example, and the frequency of the received ultrasonic waves is 3.00 MHz, for example. In Configuration 14, the B mode is used, ultrasonic waves are transmitted by the third ultrasonic element group **3c**, and ultrasonic waves are received by the third ultrasonic element group **3c**. This configuration is used for diagnosis of a part of a short distance. The frequency of the transmitted ultrasonic waves is 1.80 MHz, for example, and the frequency of the received ultrasonic waves is 1.80 MHz, for example.

In Configuration 15, the B mode is used, ultrasonic waves are transmitted by the third ultrasonic element group **3c**, and ultrasonic waves are received by the third ultrasonic element group **3c**. This configuration is used for diagnosis of a part of a short distance. The frequency of the transmitted ultrasonic waves is 2.40 MHz, for example, and the frequency of the received ultrasonic waves is 2.40 MHz, for example. In Configuration 16, the B mode is used, ultrasonic waves are transmitted by the third ultrasonic element group **3c**, and ultrasonic waves are received by the third ultrasonic element group **3c**. This configuration is used for diagnosis of a part of a short distance. The frequency of the transmitted ultrasonic waves is 2.70 MHz, for example, and the frequency of the received ultrasonic waves is 2.70 MHz, for example.

In the above examples, any one of the first ultrasonic element group **3a**, the second ultrasonic element group **3b**, and the third ultrasonic element group **3c** is selected and used for transmission of ultrasonic waves, and any one of the first ultrasonic element group **3a**, the second ultrasonic element group **3b**, and the third ultrasonic element group **3c** is selected and used for reception of ultrasonic waves. However, the invention is not limited to these examples. Any two of the first ultrasonic element group **3a**, the second ultrasonic element group **3b**, and the third ultrasonic element group **3c** may be selected and used, or all of them may be used, for transmission of ultrasonic waves. Also, any two of the first ultrasonic element group **3a**, the second ultrasonic element group **3b**, and the third ultrasonic element group **3c** may be selected and used, or all of them may be used, for reception of ultrasonic waves.

Modification Example of Ultrasonic Transducer

In the ultrasonic transducer **1** according to the above-described embodiment, the number of the first ultrasonic element **8a** of the first ultrasonic element group **3a** is one. However, the number may be two, or may be three or more. Here, explanations will be made on a case where the number of the first ultrasonic element **8a** of the first ultrasonic element group **3a** is three or more in the ultrasonic transducer **1**.

Preferably, the conducting wire for a lower electrode **711a** that is a wiring for electrically connecting each first ultrasonic element **8a** of the first ultrasonic element group **3a** in series is provided such that the total sum of distances of the conducting wires for a lower electrode **711a** between two

adjacent first ultrasonic elements **8a** which are electrically connected with each other becomes shortest. With this configuration, the voltage drop in the conducting wire for a lower electrode **711a** can be reduced.

Preferably, in the conducting wire for a lower electrode **711a** that is a wiring for electrically connecting each first ultrasonic element **8a** of the first ultrasonic element group **3a** in series, all of the distances of the conducting wires for a lower electrode **711a** between two adjacent first ultrasonic elements **8a** of the first ultrasonic element group **3a** which are electrically connected with each other are the same. With this configuration, the phase difference of ultrasonic waves between two adjacent first ultrasonic elements **8a** which are electrically connected with each other can be made the same in the first ultrasonic element group **3a**, and thus designing can be conducted easily.

Also, preferably, the distance of the conducting wire for a lower electrode **711a** between two adjacent first ultrasonic elements **8a** of the first ultrasonic element group **3a** which are electrically connected with each other, the distance **Lb**, the distance **Lc**, and the distance **Ld** are the same. With this configuration, the phase difference of ultrasonic waves between two adjacent first ultrasonic elements **8a** of the first ultrasonic element group **3a** which are electrically connected with each other, the phase difference of ultrasonic waves between two adjacent second ultrasonic elements **8b** of the second ultrasonic element group **3b** which are electrically connected with each other, the phase difference of ultrasonic waves between two adjacent third ultrasonic elements **8c** of the third ultrasonic element group **3c** which are electrically connected with each other, and the phase difference of ultrasonic waves between two adjacent third ultrasonic elements **8d** of the third ultrasonic element group **3d** which are electrically connected with each other can be made the same. Therefore, designing can be conducted easily. The ultrasonic probe **10** and the ultrasonic transducer **1** described above can be applied to various kinds of electronic instruments such as diagnostic devices in a preferred manner. Hereinafter, an embodiment of a diagnostic device will be explained as a representative of an embodiment of an electronic instrument.

Embodiment of Diagnostic Device (Electronic Instrument)

FIG. 6 is a perspective view showing an embodiment of the diagnostic device according to the invention. FIG. 7 is a block diagram showing the embodiment of the diagnostic device according to the invention. As shown in FIG. 6 and FIG. 7, the diagnostic device **100** has the above-described ultrasonic probe **10**, and the device main body **300** which is electrically connected with the ultrasonic probe **10** through the cable **210**.

The device main body **300** has a control section (control means) **310**, a drive signal generating section **320**, a detection signal processing section **330**, an image signal processing section **340**, and an image display section (display means) **350**. The signal processing section is constructed of the detection signal processing section **330** and the image signal processing section **340**. The control section **310** is constructed of a microcomputer and the like, for example, and controls the entire device main body **300** such as the drive signal generating section **320** and the image signal processing section **340**. The image display section **350** is constructed of a display device such as a CRT or an LCD, for example.

Next, the operation of the diagnostic device **100** will be explained. In conducting a test, the surface of the acoustic matching section **6** of the ultrasonic probe **10** is applied to a living body as a test target, and the diagnostic device **100** is activated. First, the control section **310** outputs a transmission order to the drive signal generating section **320**, the drive signal generating section **320** transmits a drive signal for driving each ultrasonic element **8** to the ultrasonic element **8** at a predetermined timing. In this manner, each of the ultrasonic elements **8** is driven at a predetermined timing. Then, ultrasonic waves are transmitted from the ultrasonic transducer **1** of the ultrasonic probe **10**.

The transmitted ultrasonic waves propagate through a living body, and the ultrasonic waves reflected on a predetermined part of the living body are input to the ultrasonic transducer **1** of the ultrasonic probe **10**. Then, a detection signal corresponding to the input ultrasonic waves are output from the ultrasonic transducer **1**. The detection signal is transmitted to the detection signal processing section **330** of the device main body **300** through the cable **210**. The detection signal undergoes predetermined signal processing in the detection signal processing section **330**, and is converted into a digital signal by an A/D converter included in the detection signal processing section **330**. The A/D converter is not shown in the drawing.

The digital signal output from the detection signal processing section **330** is input to the image signal processing section **340**, and is sequentially stored in a primary storing section included in the image signal processing section **340** as areal data in synchronization with a frame timing signal. The primary storing section is not shown in the drawing. The image signal processing section **340** reconstructs two-dimensional or three-dimensional image data based on each areal data, and also conducts image processing such as interpolation, response emphasis processing, or tone processing to the image data. The image data, to which image processing has been conducted, is stored in a secondary storing section included in the image signal processing section **340**. The secondary storing section is not shown in the drawing.

The image data, to which image processing has been conducted, is then read out from the secondary storing section of the image signal processing section **340** and is input to the image display section **350**. The image display section **350** displays an image based on the image data. A medical service worker such as a doctor conducts diagnosis or the like by observing an image displayed on the image display section **350**. The invention is not limited to the ultrasonic transducer, the ultrasonic probe, the diagnostic device, and the electronic instrument of the invention explained in the above based on the embodiment shown in the drawing. The configuration of each section can be replaced with any configuration that has a similar function. Also, another optional element may be added to the invention.

In the above-described embodiment, the cell unit is arranged two-dimensionally. However, the invention is not limited to this, and the cell unit can be arranged one-dimensionally, for example. Further, in the above-described embodiment, the cell units are plural. However, the invention is not limited to this, and the cell unit may be single. Further, in the above-described embodiment, the cell unit has three kinds (three sizes) of ultrasonic element groups in which the areas of the diaphragms are different. However, the invention is not limited to this, and the cell unit may have two kinds (two sizes) of ultrasonic element groups in which the areas of the diaphragms are different, or may have four

or more kinds (four or more sizes) of ultrasonic element groups in which the areas of the diaphragms are different.

In the above-described embodiment, the ultrasonic element of the first ultrasonic element group is single. However, the invention is not limited to this, and a plurality of ultrasonic elements may be provided in the first ultrasonic element group. In such a case, the first ultrasonic elements of the first ultrasonic element group are electrically connected in series. Further, according to the invention, the ultrasonic transducer (the ultrasonic probe) is not limited to a contact type sensor that is used by being brought into contact with a test target, and can be applied to a non-contact type sensor such as a proximity sensor that is used without being brought into contact with a test target.

According to one aspect of the embodiment, an ultrasonic transducer of the embodiment includes "m" first ultrasonic elements and "n" second ultrasonic elements. The "m" first ultrasonic elements include first diaphragms. The "m" first ultrasonic elements are configured and arranged to transmit and receive ultrasonic waves, where "m" represents a number of the first ultrasonic elements and is an integer of 1 or more. Each of the first diaphragms having a first area. The "n" second ultrasonic elements include second diaphragms. Each of the "n" second diaphragms has a second area being smaller than the first area. The "n" second ultrasonic elements are configured and arranged to transmit and receive the ultrasonic waves, where "n" represents a number of the second ultrasonic elements and is an integer larger than "m". The "m" first ultrasonic elements are electrically connected in series in a case where "m" is an integer of 2 or more. The "n" second ultrasonic elements are electrically connected in series. B/A is within a range of 0.9 to 1.1, when a total sum of the first areas is "A" and a total sum of the second areas is "B".

According to another aspect of the embodiment, an ultrasonic transducer includes a plurality of ultrasonic elements being arranged on the ultrasonic transducer with predetermined intervals. The plurality of ultrasonic elements include "m" first ultrasonic elements and "n" second ultrasonic elements. The "m" first ultrasonic elements include first diaphragms. The "m" first ultrasonic elements are configured and arranged to transmit and receive ultrasonic waves, where "m" represents the number of the first ultrasonic elements and is an integer of 1 or more. Each of the first diaphragms has a first area. The "n" second ultrasonic elements include second diaphragms. Each of the "n" second diaphragms has a second area being smaller than the first area. The "n" second ultrasonic elements are configured and arranged to transmit and receive the ultrasonic waves, where "n" representing the number of the second ultrasonic elements and is an integer larger than "m". The "m" first ultrasonic elements are electrically connected in series in a case where "m" is an integer of 2 or more. The "n" second ultrasonic elements are electrically connected in series. B/A is within a range of 0.9 to 1.1, when a total sum of the first areas is "A" and a total sum of the second areas is "B".

According to another aspect of the embodiment, an ultrasonic transducer includes a substrate, a supporting film, and a piezoelectric body. The substrate includes a plurality of openings. The supporting film is configured to cover the plurality of openings. The piezoelectric body is configured on the supporting film at one of the plurality of openings. The plurality of openings include "m" first openings, where "m" represents a number of the first openings and is an integer of 1 or more. Each of the first openings has a first opening area covered with the supporting film on a surface of the substrate. The plurality of openings include "n"

second openings, where "n" represents a number of the second openings and is an integer larger than "m". Each of the second openings has a second opening area that is smaller than the first area. "m" first piezoelectric bodies, which are formed corresponding to the "m" first openings, of the piezoelectric body are electrically connected in series in a case where "m" is an integer of 2 or more. "n" second piezoelectric bodies, which are formed corresponding to the "n" second openings, of the piezoelectric body are electrically connected in series. B/A is within the range of 0.9 to 1.1, when a total sum of the first opening areas is "A" and a total sum of the second opening areas is "B".

According to another aspect of the embodiment, an ultrasonic transducer includes a substrate, a supporting film, and a piezoelectric body. The substrate includes a plurality of openings. The supporting film is configured to cover the plurality of openings. The piezoelectric body is configured on the supporting film at one of the plurality of openings. The plurality of openings include an arrangement opening group with predetermined intervals. The opening group include "m" first openings, where "m" represents a number of the first openings and is an integer of 1 or more. Each of the "m" first openings has a first opening area covered with the supporting film on a surface of the substrate. The opening group includes "n" second openings, where "n" represents a number of the second openings and is an integer larger than "m". Each of the "m" second openings has a second opening area that is smaller than the first area. "m" first piezoelectric bodies, which are formed corresponding to the "m" first openings, of the piezoelectric body are electrically connected in series in a case where "m" is an integer of 2 or more. "n" second piezoelectric bodies, which are formed corresponding to the "n" second openings, of the piezoelectric body are electrically connected in series. B/A is within the range of 0.9 to 1.1, when a total sum of the first areas is "A" and a total sum of the second areas is "B".

General Interpretation of Terms

In understanding the scope of the present invention, the term "comprising" and its derivatives, as used herein, are intended to be open ended terms that specify the presence of the stated features, elements, components, groups, integers, and/or steps, but do not exclude the presence of other unstated features, elements, components, groups, integers and/or steps. The foregoing also applies to words having similar meanings such as the terms, "including", "having" and their derivatives. Also, the terms "part," "section," "portion," "member" or "element" when used in the singular can have the dual meaning of a single part or a plurality of parts. Finally, terms of degree such as "substantially", "about" and "approximately" as used herein mean a reasonable amount of deviation of the modified term such that the end result is not significantly changed. For example, these terms can be construed as including a deviation of at least $\pm 5\%$ of the modified term if this deviation would not negate the meaning of the word it modifies.

While only selected embodiments have been chosen to illustrate the present invention, it will be apparent to those skilled in the art from this disclosure that various changes and modifications can be made herein without departing from the scope of the invention as defined in the appended claims. Furthermore, the foregoing descriptions of the embodiments according to the present invention are provided for illustration only, and not for the purpose of limiting the invention as defined by the appended claims and their equivalents.

What is claimed is:

1. An ultrasonic transducer comprising:

"m" first ultrasonic elements including first diaphragms, the "m" first ultrasonic elements being configured and arranged to transmit and receive ultrasonic waves, where "m" represents a number of the first ultrasonic elements and is an integer of 1 or more, each of the first diaphragms having a first area and a piezoelectric body that is disposed on the first area; and

"n" second ultrasonic elements including second diaphragms, each of the "n" second diaphragms having a second area and a piezoelectric body that is disposed on the second area, the second area being smaller than the first area, the "n" second ultrasonic elements being configured and arranged to transmit and receive the ultrasonic waves, where "n" represents a number of the second ultrasonic elements and is an integer larger than "m",

the "m" first ultrasonic elements being electrically connected in series by a first electric connection in a case where "m" is an integer of 2 or more,

the "n" second ultrasonic elements being electrically connected in series by a second electric connection, the second electric connection being electrically disconnected from the first electric connection,

B/A being within a range of 0.9 to 1.1, when a total sum of the first areas is "A" and a total sum of the second areas is "B".

2. The ultrasonic transducer according to claim 1, wherein "n" is an integer of 3 or more, and

in wiring to connect electrically each of the "n" second ultrasonic elements in series, a distance between two adjacent second ultrasonic elements among the "n" second ultrasonic elements is the same.

3. The ultrasonic transducer according to claim 1, wherein "m" is an integer of 3 or more,

"n" is an integer of 4 or more, and

in wiring to connect electrically each of the "m" first ultrasonic elements in series, a distance between two adjacent first ultrasonic elements among the "m" first ultrasonic elements is the same.

4. The ultrasonic transducer according to claim 3, wherein "k" is an integer of 4 or more, and

in wiring to connect electrically the "k" third ultrasonic elements in series, a distance between two adjacent third ultrasonic elements among the "k" third ultrasonic elements is the same.

5. The ultrasonic transducer according to claim 1 further comprising

"k" third ultrasonic elements including third diaphragms, each of the "k" third diaphragms having a third area being smaller than the second area, the "k" third ultrasonic elements being configured and arranged to transmit and receive the ultrasonic waves, where "k" represents a number of the third ultrasonic elements and is an integer larger than "m", wherein

the "k" third ultrasonic elements are electrically connected in series, and

C/A is within the range of 0.9 to 1.1, when a total sum of the third areas is "C".

6. The ultrasonic transducer according to claim 5, wherein "m" is an integer of 3 or more,

"n" is an integer of 4 or more,

"k" is an integer of 5 or more, and

all of the distance between two adjacent first ultrasonic elements among the "m" first ultrasonic elements, the distance between two adjacent second ultrasonic among the "n" second ultrasonic elements, and the distance between two adjacent third ultrasonic elements among the "k" third ultrasonic elements are the same.

7. An ultrasonic transducer comprising:

a plurality of ultrasonic elements being arranged on the ultrasonic transducer with predetermined intervals, the plurality of ultrasonic elements including

"m" first ultrasonic elements including first diaphragms, the "m" first ultrasonic elements being configured and arranged to transmit and receive ultrasonic waves, where "m" representing the number of the first ultrasonic elements and is an integer of 1 or more, each of the first diaphragms having a first area and a piezoelectric body that is disposed on the first area, and

"n" second ultrasonic elements including second diaphragms, each of the "n" second diaphragms having a second area and a piezoelectric body that is disposed on the second area, the second area being smaller than the first area, the "n" second ultrasonic elements being configured and arranged to transmit and receive the ultrasonic waves, where "n" representing the number of the second ultrasonic elements and is an integer larger than "m",

the "m" first ultrasonic elements being electrically connected in series by a first electric connection in a case where "m" is an integer of 2 or more,

the "n" second ultrasonic elements being electrically connected in series by a second electric connection, the second electric connection being electrically disconnected from the first electric connection,

B/A being within a range of 0.9 to 1.1, when a total sum of the first areas is "A" and a total sum of the second areas is "B".

8. A probe comprising:

the ultrasonic transducer according to claim 1; and a case in which the ultrasonic transducer is accommodated.

9. A diagnostic device comprising:

the ultrasonic transducer according to claim 1; a case in which the ultrasonic transducer is accommodated; and

a device main body that is provided with a microcomputer configured to conduct a signal processing based on a signal output from the ultrasonic transducer.

10. An electronic instrument comprising:

the ultrasonic transducer according to claim 1; a case in which the ultrasonic transducer is accommodated; and

a device main body that is provided with a microcomputer configured to conduct a signal processing based on a signal output from the ultrasonic transducer.

专利名称(译)	超声波换能器，超声波探头，诊断设备和电子仪器		
公开(公告)号	US9968332	公开(公告)日	2018-05-15
申请号	US15/268918	申请日	2016-09-19
[标]申请(专利权)人(译)	精工爱普生株式会社		
申请(专利权)人(译)	SEIKO EPSON CORPORATION		
当前申请(专利权)人(译)	SEIKO EPSON CORPORATION		
[标]发明人	TSURUNO JIRO		
发明人	TSURUNO, JIRO		
IPC分类号	A61B8/00 B06B1/06		
CPC分类号	A61B8/4494 B06B1/0629 B06B1/0607		
助理审查员(译)	MCDONALD, 兆		
优先权	2012115321 2012-05-21 JP		
其他公开文献	US20170000460A1		
外部链接	Espacenet USPTO		

摘要(译)

超声换能器包括“m”个包括第一隔膜的第一超声元件，和包括第二隔膜的第二超声元件。“m”表示多个第一超声波元件，并且是1或更大的整数。每个第一膜片具有第一区域。“n”个第二超声元件包括第二膜片。每个“n”个第二膜片具有小于第一区域的第二区域。“n”表示多个第二超声波元件，并且是大于“m”的整数。在“m”是2或更大的整数的情况下，“m”个第一超声波元件串联电连接。“n”个第二超声波元件串联电连接。当第一区域的总和是“A”并且第二区域的总和是“B”时，B / A在0.9到1.1的范围内。

