



US007695436B2

(12) **United States Patent**
Mast et al.

(10) **Patent No.:** **US 7,695,436 B2**
(45) **Date of Patent:** **Apr. 13, 2010**

(54) **TRANSMIT APODIZATION OF AN
ULTRASOUND TRANSDUCER ARRAY**

(75) Inventors: **T. Douglas Mast**, Cincinnati, OH (US);
Peter G. Barthe, Phoenix, AZ (US);
Paul M. Jaeger, Mesa, AZ (US);
Waseem Faidi, Clifton Park, NY (US);
Stephen P. Leonard, Scottsdale, AZ
(US); **Michael H. Slayton**, Tempe, AZ
(US)

(73) Assignee: **Ethicon Endo-Surgery, Inc.**, Cincinnati,
OH (US)

(*) Notice: Subject to any disclaimer, the term of this
patent is extended or adjusted under 35
U.S.C. 154(b) by 263 days.

(21) Appl. No.: **10/850,959**

(22) Filed: **May 21, 2004**

(65) **Prior Publication Data**

US 2005/0261610 A1 Nov. 24, 2005

(51) **Int. Cl.**
A61B 8/00 (2006.01)

(52) **U.S. Cl.** **600/439; 600/407; 600/437**

(58) **Field of Classification Search** **600/407-480,**
600/373-386, 508-528; 601/2, 3, 4; 604/22;
606/41, 32, 49, 47; 607/115-116

See application file for complete search history.

(56) **References Cited**

U.S. PATENT DOCUMENTS

3,168,659 A	2/1965	Bayre et al.
3,902,501 A	9/1975	Citron et al.
3,927,557 A	12/1975	Viertl
4,748,985 A	6/1988	Nagasaki
4,757,820 A	7/1988	Itoh
4,798,215 A	1/1989	Turner

4,844,080 A	7/1989	Frass et al.
4,858,613 A	8/1989	Fry et al.
4,937,767 A *	6/1990	Reuschel et al. 702/124
4,960,109 A	10/1990	Lele
5,117,832 A	6/1992	Sanghvi et al.
5,238,007 A	8/1993	Giele et al.
5,242,437 A	9/1993	Everett et al.
5,295,484 A	3/1994	Marcus et al.
5,305,731 A	4/1994	Buchholtz
5,348,017 A	9/1994	Thornton et al.

(Continued)

OTHER PUBLICATIONS

Chavrier et al., "Modeling of high-intensity focused ultrasound-induced lesions in the presence of cavitation bubbles," J. Acoust. Soc. Am. 108(1), pp. 432-440 (Jul. 2000).

Watkins et al., "High-intensity focused ultrasound ablation of the kidney in a large animal model," J. Endourol., 11 (3), 191, abstract (Jun. 1997).

(Continued)

Primary Examiner—Brian Casler

Assistant Examiner—Nasir Shahrestani

(74) *Attorney, Agent, or Firm*—Verne E. Kreger, Jr.

(57) **ABSTRACT**

A system for temporal transmit apodization of an ultrasound transducer array. The system includes a waveform generator and an ultrasound transducer array having a plurality of transducer elements. Each of the transducer elements is driven by a signal generator that generates a periodic waveform. The duty cycle of each signal generator is determined by a predetermined setting of a duty cycle control. The duty cycle of each signal generator is calculated to achieve a desired beam profile of the transducer array, such as acoustic focusing for reducing the level of grating lobes and side lobes. Apodization is achieved by varying the effective amplitude at each array element by varying the duty cycle of the signal provided to each element.

16 Claims, 4 Drawing Sheets

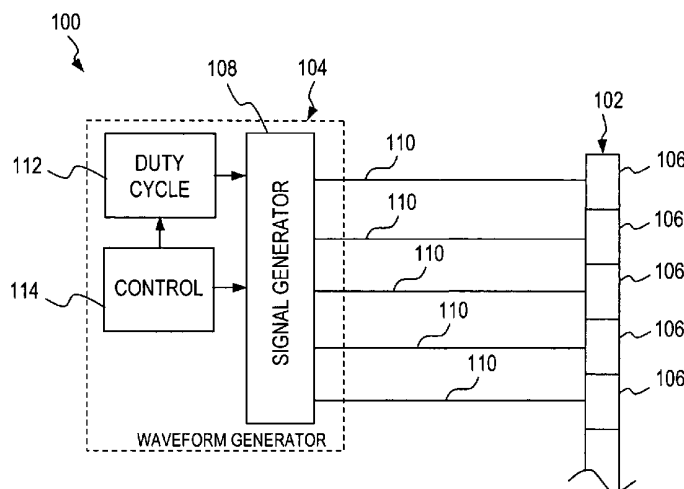

U.S. PATENT DOCUMENTS					
5,391,197	A	2/1995	Burdette et al.	6,626,855	B1 9/2003 Weng et al.
5,413,550	A	5/1995	Castel	6,645,202	B1 11/2003 Pless et al.
5,419,335	A	5/1995	Hartmann et al.	6,669,638	B1* 12/2003 Miller et al. 600/438
5,458,597	A	10/1995	Edwards et al.	6,716,184	B2 4/2004 Vaezy et al.
5,465,724	A	11/1995	Sliwa et al.	6,719,449	B1* 4/2004 Laugham et al. 366/127
5,471,988	A	12/1995	Fujio et al.	6,719,694	B2* 4/2004 Weng et al. 600/439
5,485,839	A	1/1996	Aida et al.	6,764,488	B1 7/2004 Burbank et al.
5,492,126	A	2/1996	Hennige et al.	6,770,070	B1 8/2004 Balbierz
5,500,012	A	3/1996	Brucker et al.	6,783,524	B2 8/2004 Anderson et al.
5,501,655	A	3/1996	Rolt et al.	6,887,239	B2* 5/2005 Elstrom et al. 606/41
5,514,085	A	5/1996	Yoon	6,902,536	B2 6/2005 Manna et al.
5,547,459	A*	8/1996	Kaufman et al. 601/2	6,921,371	B2 7/2005 Wilson
5,549,638	A	8/1996	Burdette	6,936,024	B1 8/2005 Houser
5,558,092	A*	9/1996	Unger et al. 600/439	6,936,048	B2 8/2005 Hurst
5,571,088	A	11/1996	Lennox et al.	6,974,417	B2* 12/2005 Lockwood et al. 600/459
5,575,288	A	11/1996	Sliwa et al.	7,037,306	B2 5/2006 Podany et al.
5,588,432	A	12/1996	Crowley	7,063,666	B2 6/2006 Weng et al.
5,620,479	A	4/1997	Diederich	7,078,015	B2 7/2006 Unger
5,630,837	A	5/1997	Crowley	2001/0007940	A1 7/2001 Tu et al.
5,657,760	A	8/1997	Ying et al.	2001/0014805	A1 8/2001 Burbank et al.
5,694,936	A	12/1997	Fujimoto et al.	2001/0037073	A1 11/2001 White et al.
5,715,825	A	2/1998	Crowley	2002/0065512	A1 5/2002 Fjeld et al.
5,728,062	A	3/1998	Brisken	2002/0068934	A1 6/2002 Edwards et al.
5,733,315	A	3/1998	Burdette et al.	2002/0087081	A1 7/2002 Serrano et al.
5,735,280	A	4/1998	Sherman et al.	2002/0087083	A1 7/2002 Nix et al.
5,759,154	A	6/1998	Hoyns	2002/0111662	A1 8/2002 Iaizzo et al.
5,762,066	A	6/1998	Law et al.	2002/0165579	A1 11/2002 Burbank et al.
5,771,896	A	6/1998	Sliwa et al.	2002/0183742	A1 12/2002 Carmel et al.
5,800,379	A	9/1998	Edwards	2002/0183771	A1 12/2002 Burbank et al.
5,820,580	A	10/1998	Edwards et al.	2002/0193781	A1 12/2002 Loeb
5,842,994	A	12/1998	TenHoff et al.	2003/0004434	A1 1/2003 Greco et al.
5,860,974	A	1/1999	Abele	2003/0013960	A1 1/2003 Makin et al.
5,876,399	A	3/1999	Chia et al.	2003/0013971	A1 1/2003 Makin et al.
5,897,523	A	4/1999	Wright et al.	2003/0018266	A1 1/2003 Makin et al.
5,931,848	A	8/1999	Saadat	2003/0018358	A1 1/2003 Saadat
5,979,453	A	11/1999	Savage et al.	2003/0028111	A1 2/2003 Vaezy et al.
5,997,534	A	12/1999	Tu et al.	2003/0040698	A1 2/2003 Makin et al.
6,001,069	A	12/1999	Tachibana et al.	2003/0047582	A1 3/2003 Sonnenschein et al.
6,004,269	A	12/1999	Crowley et al.	2003/0073907	A1 4/2003 Taylor
6,007,499	A	12/1999	Martin et al.	2003/0109786	A1 6/2003 Irioka et al.
6,014,897	A*	1/2000	Mo 73/628	2003/0120270	A1 6/2003 Acker
6,022,319	A	2/2000	Willard et al.	2003/0144593	A1 7/2003 Whitmore et al.
6,027,449	A	2/2000	Mezess et al.	2003/0212331	A1 11/2003 Fenton et al.
6,106,469	A	8/2000	Suzuki et al.	2003/0212332	A1 11/2003 Fenton et al.
6,112,123	A	8/2000	Kelleher et al.	2003/0220568	A1 11/2003 Hansmann et al.
6,135,963	A*	10/2000	Haider 600/447	2004/0006336	A1 1/2004 Swanson
6,135,971	A*	10/2000	Hutchinson et al. 601/3	2004/0030268	A1 2/2004 Weng et al.
6,138,513	A*	10/2000	Barabash et al. 73/602	2004/0143252	A1 7/2004 Hurst
6,148,224	A*	11/2000	Jensen 600/407	2004/0236375	A1* 11/2004 Redding, Jr. 607/3
6,171,248	B1	1/2001	Hossack et al.	2004/0254570	A1 12/2004 Hadjicostis et al.
6,176,842	B1	1/2001	Tachibana et al.	2005/0015107	A1 1/2005 O'Brien
6,183,469	B1	2/2001	Thapilyal et al.	2005/0085726	A1 4/2005 Lacoste et al.
6,216,704	B1	4/2001	Ingle et al.	2005/0137520	A1 6/2005 Rule et al.
6,217,576	B1	4/2001	Tu et al.	2005/0228286	A1 10/2005 Messerly et al.
6,221,018	B1*	4/2001	Ramamurthy et al. 600/443	2005/0240125	A1 10/2005 Makin et al.
6,231,834	B1*	5/2001	Unger et al. 424/9.51	2005/0261585	A1 11/2005 Makin et al.
6,361,531	B1	3/2002	Hissong	2005/0261587	A1 11/2005 Makin et al.
6,379,320	B1	4/2002	Lafon et al.	2005/0267488	A1 12/2005 Hare et al.
6,425,867	B1	7/2002	Vaezy et al.	2006/0052695	A1* 3/2006 Adam 600/437
6,482,178	B1	11/2002	Andrews et al.	2006/0052701	A1 3/2006 Carter et al.
6,508,774	B1	1/2003	Acker et al.	2006/0173348	A1 8/2006 Wilser et al.
6,512,957	B1	1/2003	Witte	2006/0235306	A1 10/2006 Cotter et al.
6,521,211	B1	2/2003	Unger et al.	2007/0021691	A1 1/2007 Nita et al.
6,533,726	B1	3/2003	Lizzi et al.	2008/0058648	A1* 3/2008 Novak et al. 600/471
6,546,934	B1	4/2003	Ingle et al.		
6,575,956	B1*	6/2003	Brisken et al. 604/500		
6,599,245	B1*	7/2003	Ma et al. 600/437		
6,602,251	B2	8/2003	Burbank et al.		
6,613,004	B1*	9/2003	Vitek et al. 601/2		
6,618,620	B1	9/2003	Freundlich et al.		

OTHER PUBLICATIONS

Billard, et al., "Effects of Physical Parameters in High Temperature Ultrasound Hyperthermia," *Ultrasound in Medicine and Biology*, vol. 16, Issue 4, pp. 409-420 (1990).

* cited by examiner

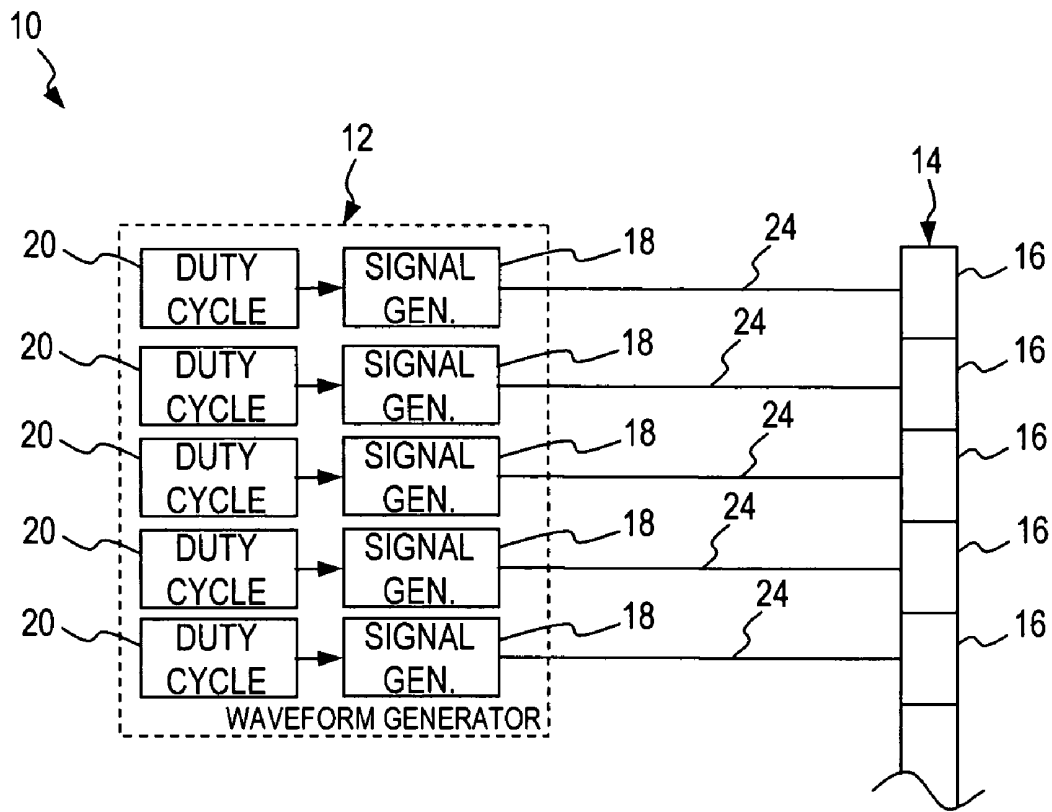

FIG. 1

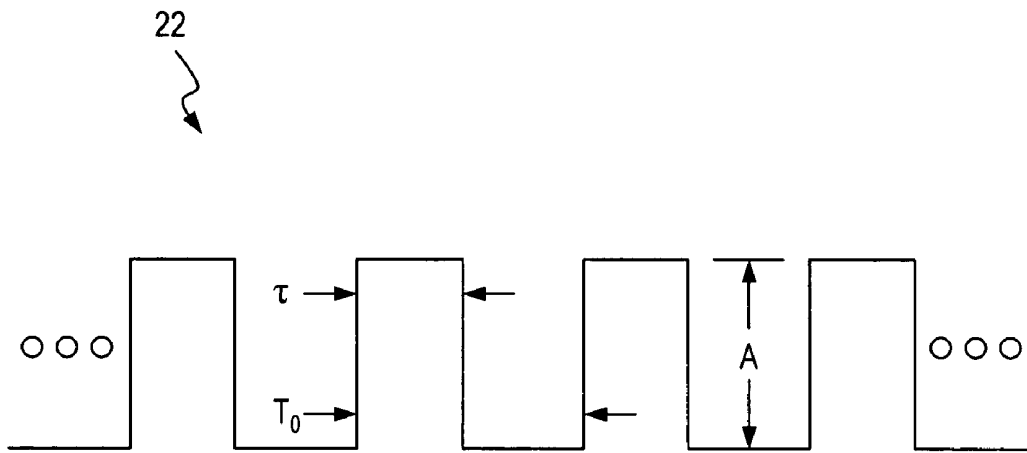

FIG. 2

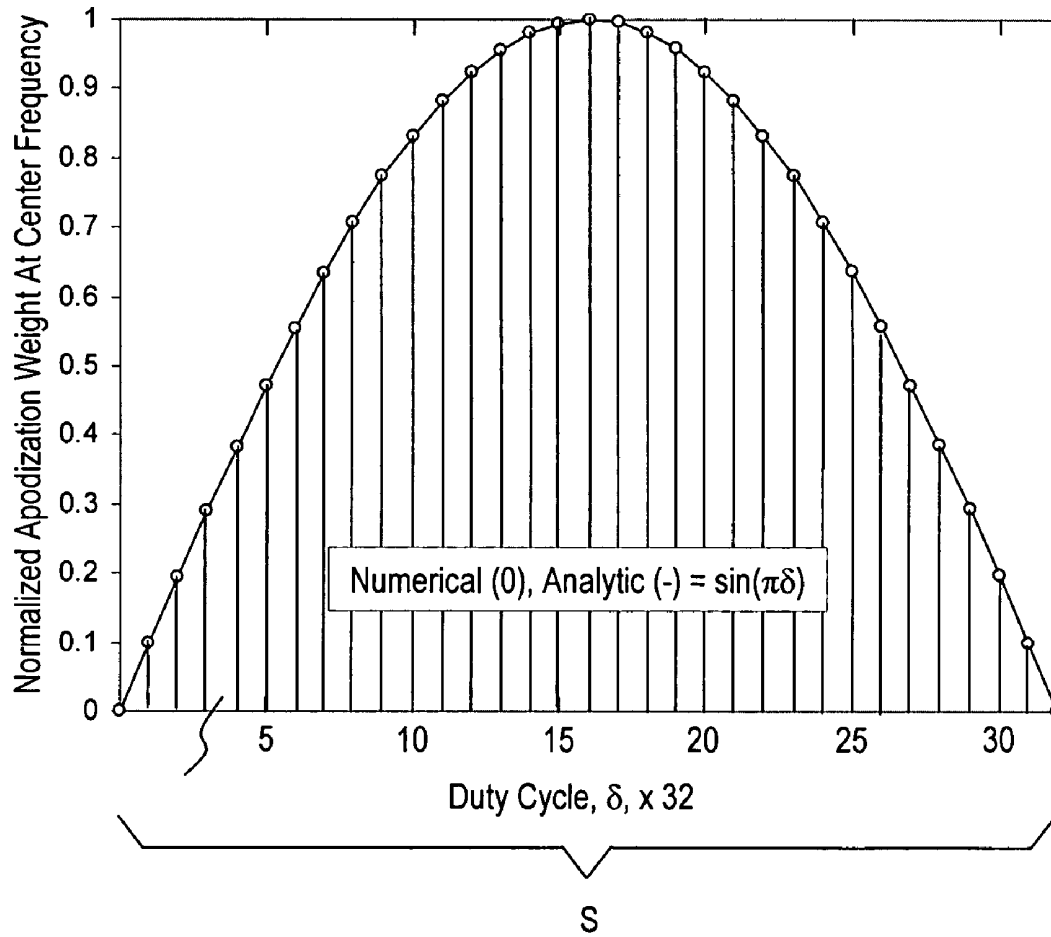

FIG. 3

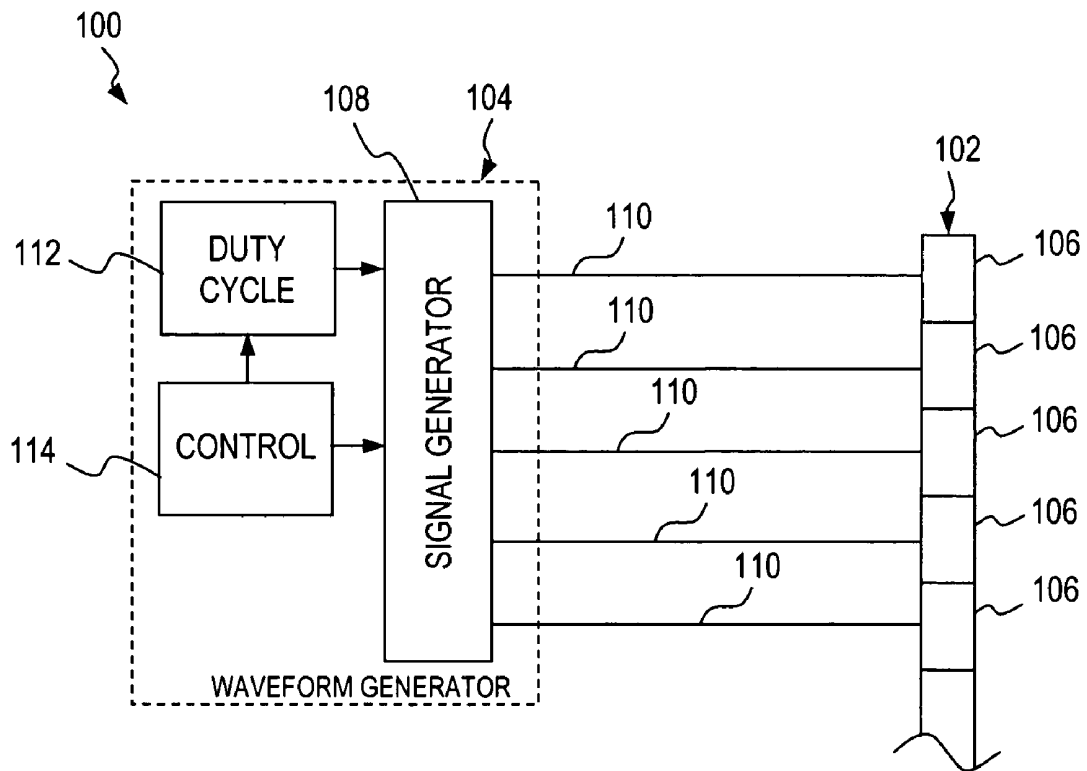

FIG. 4

TRANSMIT APODIZATION OF AN ULTRASOUND TRANSDUCER ARRAY

FIELD OF THE INVENTION

The present invention relates generally to ultrasound, and more particularly, to an ultrasound medical system having an ultrasound source and an acoustic transducer array.

BACKGROUND OF THE INVENTION

Sound waves that have a frequency greater than approximately 20 kHz are referred to in the art as "ultrasound." In the medical field, ultrasound waves are useful for both diagnostic and therapeutic applications. Medical diagnostic ultrasound systems are useful for generating images of anatomical structures within a target area of a patient's body. The images are obtained by scanning a target area with waves of ultrasound energy. In therapeutic ultrasound applications, high intensity ultrasound energy is transmitted into a target area to induce changes in state of the target. High-intensity focused ultrasound ("HIFU") pulses induce changes in tissue state through thermal effects (e.g., induced hyperthermia) and mechanical effects (e.g., induced cavitation).

The use of high intensity focused ultrasound to destroy tissue or to alter the characteristics of tissue at a target location, volume, region or area within a larger mass, body or area of anatomical tissue presents many advantages, including minimization of trauma and pain for the patient, reductions in surgical incisions, stitches and exposure of internal tissue, avoidance of damage to tissue other than that which is to be treated, altered or removed, lack of a harmful cumulative effect from the ultrasound energy on the surrounding non-target tissue, reduction in treatment costs, elimination of the need in many cases for general anesthesia, reduction of the risk of infection and other complications, avoidance of blood loss, and the ability for high intensity focused ultrasound procedures to be performed in non-hospital sites and/or on an out-patient basis.

In high-intensity focused ultrasound hyperthermia treatments, intensity of ultrasonic waves generated by a highly focused transducer increases from the source to the region of focus where it can reach a very high temperature. The absorption of the ultrasonic energy at the focus induces a sudden temperature rise of tissue, which causes ablation of a target volume of cells in the focal region. Thus, as an example, HIFU hyperthermia treatments can cause necrotization of an internal lesion without damage to the intermediate tissues. The focal region dimensions are referred to as the depth of field, and the distance from the transducer to the center point of the focal region is referred to as the depth of focus. Ultrasound is a promising non-invasive surgical technique because the ultrasonic waves provide a non-effective penetration of intervening tissues, yet with sufficiently low attenuation to deliver energy to a small focal target volume. Currently there is no other known modality that offers noninvasive, deep, localized focusing of non-ionizing radiation for therapeutic purposes. Thus, ultrasonic treatment has a great advantage over microwave and radioactive therapeutic treatment techniques.

The beam emitted by a single ultrasound focused transducer element is generally effective within a fixed region, called the "focal zone." This focal zone frequently is smaller than the size of the target tissue. Treatment of extensive targets is consequently a problem. A solution to this shortcoming is to utilize a transducer comprising a plurality of individual transducer elements arranged closely together to form

an array. These arrays are focused at the desired treatment site through a combination geometric and electronic focusing. Geometric focusing is determined by the physical geometry of the array, while electronic focusing involves the use of phase delays and wave interference to achieve constructive interference at the target tissue. Electronic focusing allows movement of the treatment location without the need for mechanical movement of the array.

When a plurality of transducer elements are arranged in an array and are energized to propagate a steerable acoustic beam, the beam includes a main lobe, a plurality of small side lobes and one or more grating lobes. Grating lobes originate from acoustic waves that combine along various axes that differ from the axis of the main lobe. Grating lobes are present in the acoustic beams propagated from nearly all linear arrays and normally contain substantial energy. Side lobes are secondary points of focus outside the treatment region as a result of diffraction of the ultrasound waves passing through a structure, such as tissue or bone. The appearance of grating lobes and side lobes decreases the power radiated to the focal point, reducing the effectiveness of treatment.

It is known in the art to minimize grating lobes and side lobes by transmit apodization, wherein the effective drive amplitude of at least a portion of the elements of an array is varied to affect the shape of the beam. Varying the transmit amplitude at individual elements of the array typically requires the use of variable or switched-rail power supplies or inefficient linear amplifiers at each drive channel. Such drive mechanisms are slow, prohibitively bulky, and costly, particularly considering the large number of array elements present in a typical transducer and the number of element apodization levels necessary for beamshaping.

Pulse width variation has previously been considered for transmit apodization in association with ultrasound imaging, such as in U.S. Pat. No. 6,135,963 to Haider and U.S. Pat. No. 6,599,245 to Ma et al. As is well-known in the art, a relatively short transmit pulse is preferable for imaging, and a single pulse is often used. If a single pulse is apodized by adjusting its width, the frequency spectrum of the electrical signal supplied to the transducer to generate a corresponding ultrasound signal will likewise be significantly modified. Thus, if various transmit apodization pulse widths are applied to different array elements, the focusing, frequency spectrum and effective amplitude of the aggregate ultrasonic treatment signal emitted by the transducer will vary. This may result in undesired effects. For example, ultrasound array elements typically have limited bandwidth so there is a severe limit to the amount of useful apodization that is possible. In addition, if the transmit waveshapes are different between elements of an array, the aggregated ultrasound signals of the elements do not efficiently form a focused beam. Also, any electrical matching required to couple the electrical signal to a transducer element can drastically alter the transmit pulse shape. As a result, apodization is of limited value for ultrasound imaging.

The desired characteristics of transmit apodization of ultrasound signals for therapeutic purposes differs considerably from signals transmitted for imaging. In particular, therapeutic transducers transmit an ultrasonic pulse train for a relatively long period of time. As a result, the center of the frequency spectrum is retained generally at the pulse repetition frequency of the pulse train and is not "pulled," rolled-off or skewed as with a transient pulse or a pulse train of short duration. If the width of the repeating pulses is short, such as a repeating pulse train of narrow spikes, the frequency spectrum broadens out and decreases in amplitude, but the peak of the spectrum remains at the pulse repetition frequency. Like-

wise, as the duty cycle of the pulse train increases towards a symmetrical shape (i.e., approximately equal times in "high" and "low" logical states) the effective amplitude of an array element increases. As a result of these characteristics, transmit apodization of ultrasound signals in the manner known for imaging will not produce satisfactory results when applied to therapeutic ultrasound signals.

Still, scientists and engineers continue to seek improved ultrasound medical systems. There is a need for a more efficient way to achieve transmit apodization of therapeutic ultrasound transducers.

SUMMARY OF THE INVENTION

A system for temporal transmit apodization of an ultrasound transducer array is disclosed according to an embodiment of the present invention. The system includes a waveform generator and an ultrasound transducer array having a plurality of transducer elements.

The waveform generator includes a plurality of signal generators, each coupled to an associated duty cycle control. The signal generators each produce an electrical signal having a period, amplitude and impedance compatible with the transducer elements. The duty cycle controls are each adapted to set the duty cycle of an associated signal generator.

The ultrasound transducer array may be arranged in a pattern of concentric circles. Alternatively, a plurality of elements may be arranged linearly for subdermal insertion with a minimum of trauma to surrounding tissue.

The duty cycle of each signal generator is determined by a predetermined setting of a duty cycle control. The duty cycle of each signal generator is calculated to achieve a desired beam profile of the transducer array, such as acoustic focusing for reducing the level of grating lobes and side lobes. Apodization is achieved by varying the effective amplitude at each array element by varying the duty cycle of the signal provided to each element, rather than using variable or switched-rail power supplies, or linear amplifiers. As a result, apodization can be accomplished efficiently by digital means, using components having less complexity than commonly found with analog ultrasound systems.

BRIEF DESCRIPTION OF THE FIGURES

FIG. 1 is a block diagram of an ultrasound transmission system for therapeutic treatment according to an embodiment of the present invention;

FIG. 2 depicts a periodic pulse train generated by the system of FIG. 1;

FIG. 3 shows the representation of apodization weights versus duty cycle of the periodic pulse train of FIG. 2; and

FIG. 4 is a block diagram of an ultrasound transmission system for therapeutic treatment according to an alternate embodiment of the present invention.

DETAILED DESCRIPTION OF THE INVENTION

A system 10 for temporal transmit apodization of an ultrasound transducer array is shown in FIG. 1 according to an embodiment of the present invention. System 10 includes a waveform generator 12 and an ultrasound transducer array 14.

Transducer 14 may be any conventional type of ultrasound transducer having a plurality of transducer elements 16 that may be focused by any conventional geometric and electronic focusing means. For example, elements 16 may be arranged in a pattern of concentric circles. Alternatively, a plurality of

elements 16 may be arranged linearly for subdermal insertion with a minimum of trauma to surrounding tissue.

Waveform generator 12 includes a plurality of signal generators 18, each coupled to an associated duty cycle control 20. Signal generators 18 each produce a digital, generally square-wave electrical signal having a period, amplitude and impedance compatible with elements 16 of transducer 14. Duty cycle controls 20 each are adapted to set the duty cycle of an associated signal generator 18. The drive signals produced by signal generators 18 are coupled to associated elements 16 of transducer 14 by any conventional means, such as wires 22. Although separate signal generators 18 and duty cycle controls 20 are depicted in FIG. 1, one skilled in the art will recognize that a fewer number of signal generators and/or duty cycle controls may be utilized and controlled in any conventional manner to provide electrical signals of varying duty cycles to each transducer element 16. In addition, although not shown, conventional signal conditioning may be applied to the electrical signals generated by signal generators 18 including, without limitation, filters such as bandpass filters and digital signal processors.

With continued reference to FIG. 1, a drive signal pulse train 22 is a periodic rectangular waveform. Pulse train 22 is coupled to transducer elements 16 by signal generators 18 as shown in FIG. 2. Pulse train 22 has an amplitude A, a period T_0 and a pulse width τ . Pulse train 22 thus has a duty cycle of τ/T_0 . Elements 16 can be driven by pulse train 22, each element being driven with signals having a like amplitude "A" but different duty cycles. The frequency spectrum, $G(f)$, of pulse train 22 may be represented by Equation 1:

$$G(f) = \frac{1}{T_0} \sum_{n=-\infty}^{n=\infty} A\tau \frac{\sin\left(\pi n \frac{\tau}{T_0}\right)}{\pi n \frac{\tau}{T_0}} \delta\left(f - \frac{n}{T_0}\right) \quad \text{Equation 1}$$

where n is a term coefficient of the series of pulses in pulse train 22, δ represents the delta function and f is the frequency of the pulse train.

At the fundamental frequency of pulse train 22,

$$f = f_0 = \frac{1}{T_0},$$

and $n=1$ such that the spectral amplitude of the pulse train is given by Equation 2:

$$G(f_0) = \frac{A}{\pi} \sin\left(\pi \frac{\tau}{T_0}\right) \quad \text{Equation 2}$$

By varying the duty cycle τ/T_0 between 0 and 50% the effective spectral amplitude $G(f_0)$ varies between normalized values of 0 and 1, as shown in FIG. 3. This variation may be used to weight, or apodize, the transmit amplitude of an array element 16 during therapy.

With reference to FIG. 3 in combination with FIG. 2, the period T_0 may be divided into a plurality of segments "S" of equal duration. The number of segments of period T_0 are preferably any value 2^x , where x is zero or any positive integer. For example, if $x=5$, the number of segments is 32. The duty cycle of a pulse train 22 divided into 32 segments may be varied between $1/32$ or 0%, and $31/32$ or 100%. For the nontrivial

case of $1/32$ to $31/32$, the spectral amplitude of pulse train **22** may vary in the form of $\sin(\pi\delta)$ where δ now represents the duty cycle, $\delta=(1$ to $31)/32$. The apodization rises from zero at zero duty cycle to unity at 50% duty cycle, and drops off toward zero for greater duty cycles.

If an even number of segments exist, such as a period dividable into N pulse widths, then

$$\frac{N}{2} + 1$$

unique levels of apodization exist. An apodization of zero equates to an off element **20**, while an apodization of 1 indicates a fully-on element. A total of $N/2$ segments may thus be used to control an element **20** between the fully-off and fully-on states. For $N=32$, pulse widths ranging from $1/32$ to $31/32$ are possible.

Example apodization levels are tabulated of the period T_0 where the number of segments "S" is 16 in Table 1.

TABLE 1

Temporal Weighting, 16 Segments		
Duty Cycle	Weight	[dB]
8/16	1.000	0.00
7/16	0.976	-0.22
6/16	0.917	-0.75
5/16	0.826	-1.66
4/16	0.706	-3.03
3/16	0.534	-5.45
2/16	0.366	-8.74
1/16	0.185	-14.68

Example apodization levels for a period T_0 where the number of segments "S" is 32 is shown in Table 2:

TABLE 2

Temporal Weighting, 32 Segments		
Duty Cycle	Weight	[dB]
16/32	1.000	0.00
15/32	0.992	-0.07
14/32	0.976	-0.22
13/32	0.951	-0.44
12/32	0.917	-0.75
11/32	0.875	-1.16
10/32	0.826	-1.66
9/32	0.769	-2.28
8/32	0.706	-3.03
7/32	0.611	-4.28
6/32	0.534	-5.45
5/32	0.452	-6.90
4/32	0.366	-8.74
3/32	0.276	-11.17
2/32	0.185	-14.68
1/32	0.092	-20.73

With reference to FIGS. 1-3 in combination, in operation each of transducer elements **16** are driven by a signal generator **18** that generates a drive signal similar to that of FIG. 2. The duty cycle of each signal generator **18** is determined by a predetermined setting of a duty cycle control **20**. The duty cycle of each signal generator **18** is preferably calculated to achieve a desired beam profile of transducer array **14**, such as acoustic focusing for reducing the level of grating lobes and

side lobes. Apodization is achieved by varying the effective amplitude at each array element **16** by varying the duty cycle of the signal provided to each element, rather than using variable or switched-rail power supplies, or linear amplifiers.

As a result, apodization can be accomplished efficiently by digital signal generation and control means, using components having less complexity than commonly found with analog ultrasound systems. Example digital signal generation means include, without limitation, digital waveform generators, pulse width modulators and semiconductors power switching devices such as, without limitation, bipolar transistors and MOSFETs. Example digital control means include, without limitation, microprocessors, microcontrollers, computers, and predetermined instructions such as computer programs.

An alternate embodiment of the present invention, shown in FIG. 4, illustrates how the present invention may be used with a single signal generator and duty cycle control. In this implementation a system **100** for temporal transmit apodization of an ultrasound transducer array includes a transducer array **102** and a waveform generator **104**.

Transducer array **102** may be any conventional type of ultrasound transducer having a plurality of transducer elements **106** that may be focused by any conventional geometric and electronic focusing means. For example, elements **106** may be arranged in a pattern of concentric circles. Alternatively, a plurality of elements **106** may be arranged linearly for subdermal insertion with a minimum of trauma to surrounding tissue.

Waveform generator **104** includes a signal generator **108** having multiple outputs **110**, each output coupled to an array element **106**. Signal generator **108** produces at each output **110** a digital, generally square-wave electrical signal having a period, amplitude and impedance compatible with elements **106** of transducer **102**. A duty cycle control **112** is adapted to provide at least one duty cycle control signal to signal generator **108** for individually controlling the duty cycle of the signals present at outputs **110**. A control **114** may utilize a processor (not shown) such as a microprocessor and a predetermined set of instructions, such as a computer program (not shown), to determine the proper duty cycle for each element **106**. In one embodiment, duty cycle instructions may be provided to duty cycle control **112**. Duty cycle control **112** in turn provides signal generator **108** with information regarding the required duty cycle for each output **110**. Alternatively, duty cycle information for each output **110** may be stored in a conventional data memory (not shown) such as a static RAM or flash memory. The data memory may be located within duty cycle control **112** or signal generator **108**.

With reference to FIGS. 2, 3 and 4 in combination, in operation each element **106** of a transducer array **104** are driven by a signal generator **108** that generates a plurality of output drive signals **110** similar to that of FIG. 2. The duty cycle of each output signal **110** is determined by a predetermined setting of a duty cycle control **112**. The predetermined setting may be provided to at least one of signal generator **108** and duty cycle control **112** by a control portion **114**. The duty cycle of each output **110** is preferably calculated to achieve a desired beam profile of transducer array **104**, such as acoustic focusing for reducing the level of grating lobes and side lobes.

Apodization of array elements **106** is achieved by varying the effective amplitude at each element by varying the duty cycle of the signal provided to each element, rather than using variable or switched-rail power supplies, or linear amplifiers. As a result, apodization can be accomplished efficiently by digital means, using components having less complexity than commonly found with analog ultrasound systems. Example

digital signal generation means include, without limitation, digital waveform generators, pulse width modulators and semiconductors power switching devices such as, without limitation, bipolar transistors and MOSFETs. Example digital control means include, without limitation, microprocessors, microcontrollers, computers, and predetermined instructions such as computer programs. In addition, a single signal generator and duty cycle control of the system **100** depicted in FIG. **4** requires fewer components as compared to the system **10** of FIG. **1**.

System **100** provides several features, such as programmability of elements **106** duty cycles for varying conditions and needs. For example, the duty cycle may be varied in response to a feedback signal (not shown) indicating a need for a change in the electronic focus of transducer array **102** or the effective amplitude of the ultrasound signal emitted by the transducer array. Control **114** may respond to the change requirement by adjusting the duty cycle of each transducer element **106** in a predetermined manner to accomplish the change.

While the present invention has been illustrated by a description of several embodiments, it is not the intention of the applicants to restrict or limit the spirit and scope of the appended claims to such detail. Numerous other variations, changes, and substitutions will occur to those skilled in the art without departing from the scope of the invention. For instance, the ultrasound medical system of the invention has application in ultrasound imaging and robotic assisted surgery taking into account the obvious modifications of such systems, components and methods to be compatible with such a imaging and robotic systems. It will be understood that the foregoing description is provided by way of example, and that other modifications may occur to those skilled in the art without departing from the scope and spirit of the appended claims.

What is claimed is:

1. A system for generating a therapeutic ultrasound signal, comprising:

a medical-treatment transducer array having a plurality of transducer elements, each element being adapted to convert a periodic electrical signal to an ultrasound signal; and

a waveform generator coupled to at least one transducer element and including:

at least one signal generator adapted to transmit a periodic electrical signal to the transducer element, and
at least one duty cycle control adapted to control the duty cycle of the periodic electrical signal of an associated signal generator,

wherein the duty cycle of the periodic electrical signal is associated with a plurality of weighted apodization levels derived by dividing the period of the periodic electrical signal into a plurality of equal segments, and

wherein each of at least a plurality of the transducer elements emit ultrasound signals having a different effective amplitude from each other of the plurality of the transducer elements in accordance with the duty cycle of an associated periodic electrical signal, such that the transducer array emits an apodized therapeutic ultrasound signal.

2. The system of claim **1** wherein:

each transducer element is separately coupled to one of a plurality of signal generators;

each signal generator is coupled to one of a plurality of duty cycle controls; and

each duty cycle control is adapted control the duty cycle of an associated signal generator such that each signal generator generates a predetermined periodic electrical signal.

3. The system of claim **1** wherein the periodic electrical signal to the transducer element is a rectangular waveform.

4. The system of claim **1** wherein the apodized ultrasound signal is tailored to reduce the level of grating lobes and side lobes.

5. A method for generating a therapeutic ultrasound signal, comprising the steps of:

providing a medical-treatment transducer array having a plurality of transducer elements, each element being adapted to convert a periodic electrical signal to an ultrasound signal;

coupling to at least one transducer element a waveform generator having:

at least one signal generator adapted to generate and transmit a periodic electrical signal to the transducer element, and

at least one duty cycle control adapted to control the duty cycle of the periodic electrical signal of an associated signal generator; and

associating the duty cycle of the periodic electrical signal with a plurality of weighted apodization levels derived by dividing the period of the periodic electrical signal into a plurality of equal segments,

wherein each of at least a portion of the transducer elements emit ultrasound signals having a different effective amplitude from each other of the portion of the transducer elements in accordance with the duty cycle of an associated periodic electrical signal, such that the transducer array emits an apodized therapeutic ultrasound signal.

6. The method of claim **5**, further comprising the steps of: separately coupling one of a plurality of signal generators to each transducer element;

separately coupling one of a plurality of duty cycle controls to each signal generator; and

wherein each duty cycle control is adapted control the duty cycle of an associated signal generator such that each signal generator generates a predetermined periodic electrical signal.

7. The method of claim **5**, further comprising the step of providing a rectangular periodic electrical signal to the transducer element.

8. The method of claim **5**, further comprising the step of tailoring the apodized ultrasound signal to reduce the level of grating lobes and side lobes.

9. A system for generating a therapeutic ultrasound signal, comprising:

a medical-treatment transducer array having a plurality of transducer elements, each element being adapted to convert a periodic electrical signal to an ultrasound signal; and

a waveform generator coupled to at least one transducer element, including:

a signal generator adapted to generate and transmit a plurality of periodic electrical signals to the transducer elements by means of a plurality of outputs,

a duty cycle control adapted to control the duty cycle of the periodic electrical signals generated by the signal generator, and

a control portion adapted to control at least one of the duty cycle control and the signal generator;

wherein the duty cycle of the periodic electrical signal is associated with a plurality of weighted apodization lev-

9

els derived by dividing the period of the periodic electrical signal into a plurality of equal segments, and wherein each of at least a portion of the transducer elements emit ultrasound signals having a different effective amplitude from each other of the portion of the transducer elements in accordance with the duty cycle of an associated periodic electrical signal, such that the transducer array emits an apodized therapeutic ultrasound signal.

10. The system of claim 9 wherein the control portion is a digital control.

11. The system of claim 9 wherein the periodic electrical signal to the transducer elements is a rectangular waveform.

12. The system of claim 9 wherein the apodized ultrasound signal is tailored to reduce the level of grating lobes and side lobes.

13. A method for generating a therapeutic ultrasound signal, comprising the steps of:
providing a medical-treatment transducer array having a plurality of transducer elements, each element being adapted to convert a periodic electrical signal to an ultrasound signal; and
coupling to at least one transducer element a waveform generator having:
a signal generator adapted to generate and transmit a periodic electrical signal to the transducer element,

10

a duty cycle control adapted to control the duty cycle of the periodic electrical signal of an associated signal generator, and

a control portion adapted to control at least one of the duty cycle control and the signal generator; and

associating the duty cycle of the periodic electrical signal with a plurality of weighted apodization levels derived by dividing the period of the periodic electrical signal into a plurality of equal segments,

wherein each of at least a portion of the transducer elements emit ultrasound signals having a different effective amplitude from each other of the portion of the transducer elements in accordance with the duty cycle of an associated periodic electrical signal, such that the transducer array emits an apodized therapeutic ultrasound signal.

14. The method of claim 13, further comprising the step of providing a digital control.

15. The method of claim 13, further comprising the step of providing a rectangular periodic electrical signal to the transducer element.

16. The method of claim 13, further comprising the step of tailoring the apodized ultrasound signal to reduce the level of grating lobes and side lobes.

* * * * *

专利名称(译)	传输超声换能器阵列的切趾		
公开(公告)号	US7695436	公开(公告)日	2010-04-13
申请号	US10/850959	申请日	2004-05-21
[标]申请(专利权)人(译)	MAST T d设定 BARTHE PETER 摹 JAEGER PAUL 中号 FAIDI 克瓦 LEONARD STEPHEN P 斯雷顿MICHAEL ^ h		
申请(专利权)人(译)	MAST T d设定 BARTHE PETER 摹 JAEGER PAUL 中号 FAIDI 克瓦 LEONARD STEPHEN P 斯雷顿MICHAEL ^ h		
当前申请(专利权)人(译)	ETHICON LLC		
[标]发明人	MAST T DOUGLAS BARTHE PETER G JAEGER PAUL M FAIDI WASEEM LEONARD STEPHEN P SLAYTON MICHAEL H		
发明人	MAST, T. DOUGLAS BARTHE, PETER G. JAEGER, PAUL M. FAIDI, WASEEM LEONARD, STEPHEN P. SLAYTON, MICHAEL H.		
IPC分类号	A61B8/00 A61H1/00 G01S7/52 G10K11/34		
CPC分类号	G10K11/348 G01S7/52047		
助理审查员(译)	SHAHRESTANI, 纳西尔		
其他公开文献	US20050261610A1		
外部链接	Espacenet USPTO		

摘要(译)

一种用于超声换能器阵列的时间发射变迹的系统。该系统包括波形发生器和具有多个换能器元件的超声换能器阵列。每个换能器元件由产生周期波形的信号发生器驱动。每个信号发生器的占空比由占空比控制的预定设置确定。计算每个信号发生器的占空比以实现换能器阵列的所需光束轮廓，例如用于降低栅瓣和旁瓣水平的声聚焦。通过改变提供给每个元件的信号的占空比来改变每个阵列元件处的有效幅度来实现切趾。

