



US 20150209008A1

(19) **United States**  
(12) **Patent Application Publication**  
**Ridley et al.**

(10) **Pub. No.: US 2015/0209008 A1**  
(43) **Pub. Date: Jul. 30, 2015**

(54) **ULTRASOUND DEVICE FOR PROBE GUIDANCE AND STERILIZABLE SHIELD FOR SAME**

(52) **U.S. CL.**  
CPC ..... *A61B 8/4422* (2013.01); *A61B 8/4209* (2013.01)

(71) Applicant: **Soma Development, LLC**, Englewood, CO (US)

(57) **ABSTRACT**

(72) Inventors: **Stephen F. Ridley**, Columbia, SC (US);  
**M. Dexter Hagy**, Greenville, SC (US)

Disclosed are medical probe devices and methods for use guiding of percutaneous probes during medical procedures. The probe devices include an ultrasound transducer housing having a passage therethrough configured to accommodate a probe. The devices can be utilized to guide a probe through the probe guide to a percutaneous target with real time visualization of the probe during the procedure. In addition, the devices can include a sterilizable shield including a sterile probe guide such that the transducer housing itself can be separated from a subject by a sterile barrier. The sterilizable shield can be a single-use shield that can prevent contamination and re-use of the shield. The devices can define a beneficial geometry conducive to use by a single operator that can be utilized for percutaneous targets near the skin surface and can enable excellent contact between the device and the skin surface of a subject.

(21) Appl. No.: **14/680,424**

(22) Filed: **Apr. 7, 2015**

**Related U.S. Application Data**

(60) Continuation of application No. 13/919,433, filed on Jun. 17, 2013, now abandoned, which is a division of application No. 12/576,487, filed on Oct. 9, 2009, now Pat. No. 8,761,862.

**Publication Classification**

(51) **Int. Cl.**  
*A61B 8/00* (2006.01)

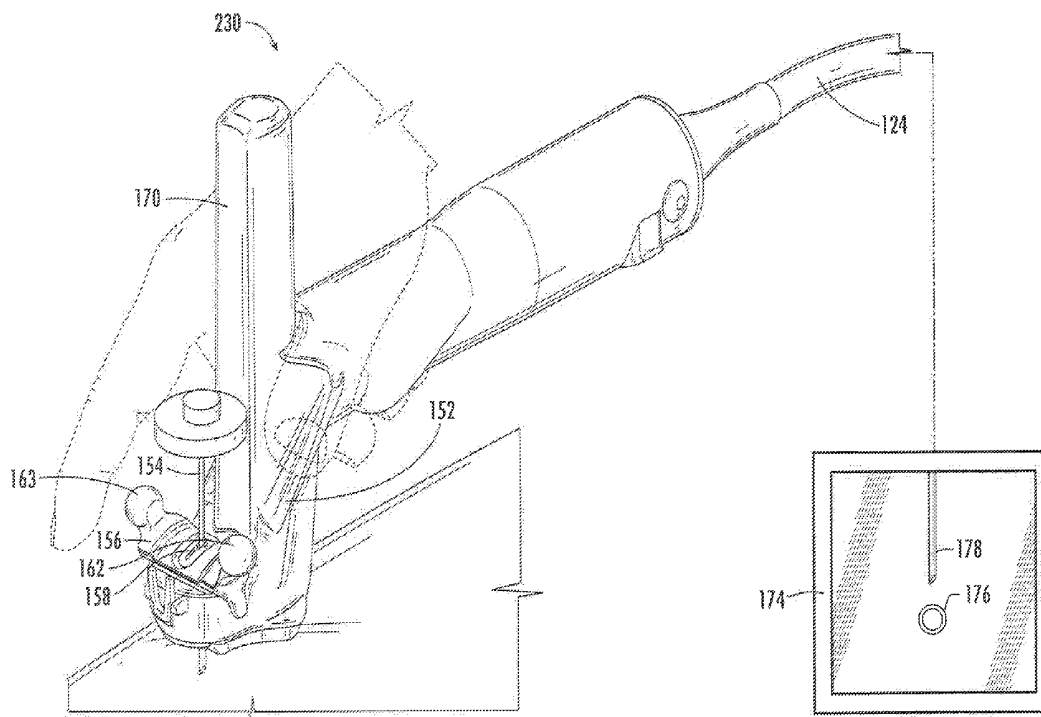

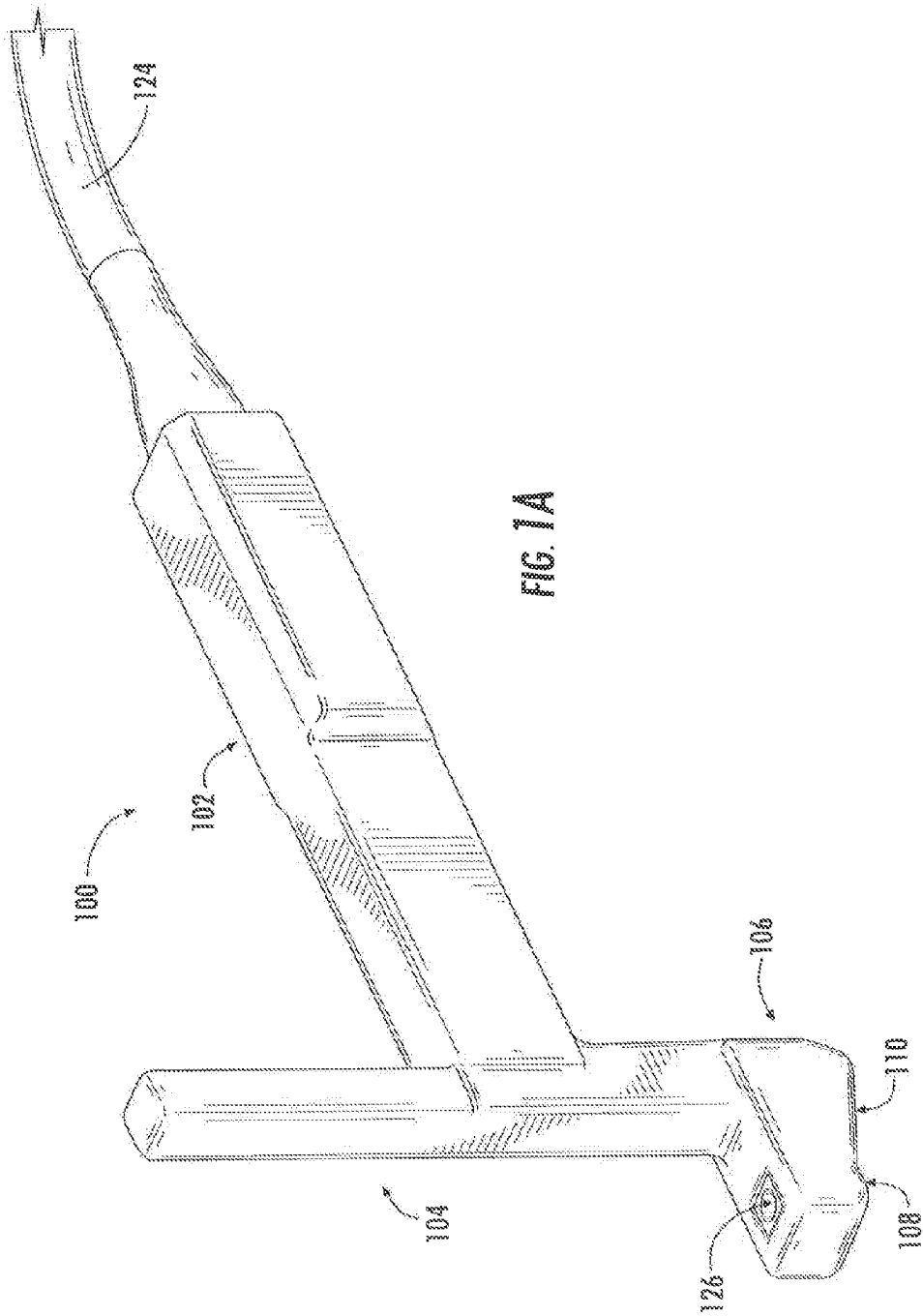
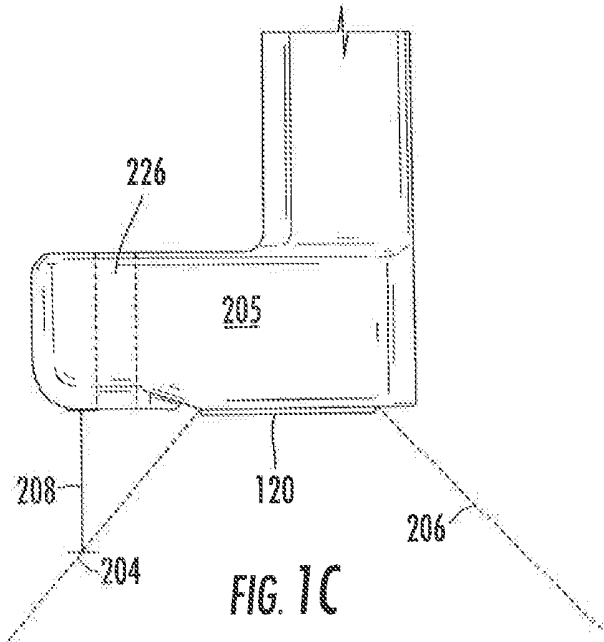
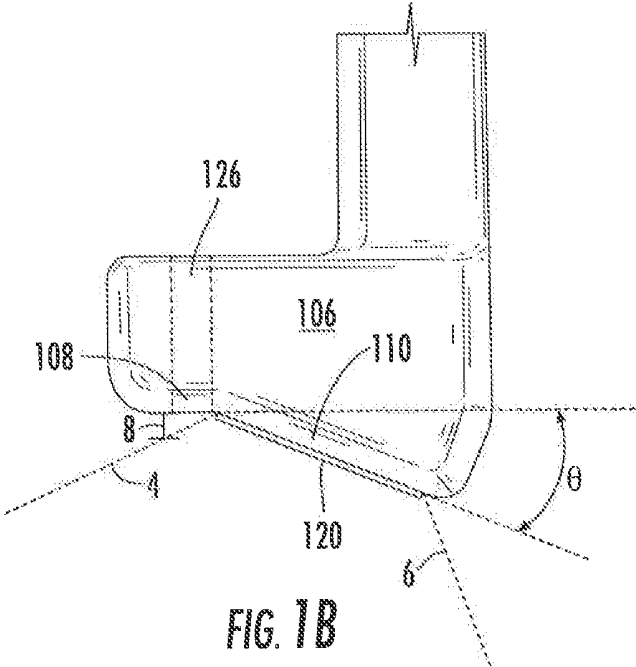

FIG. 1A



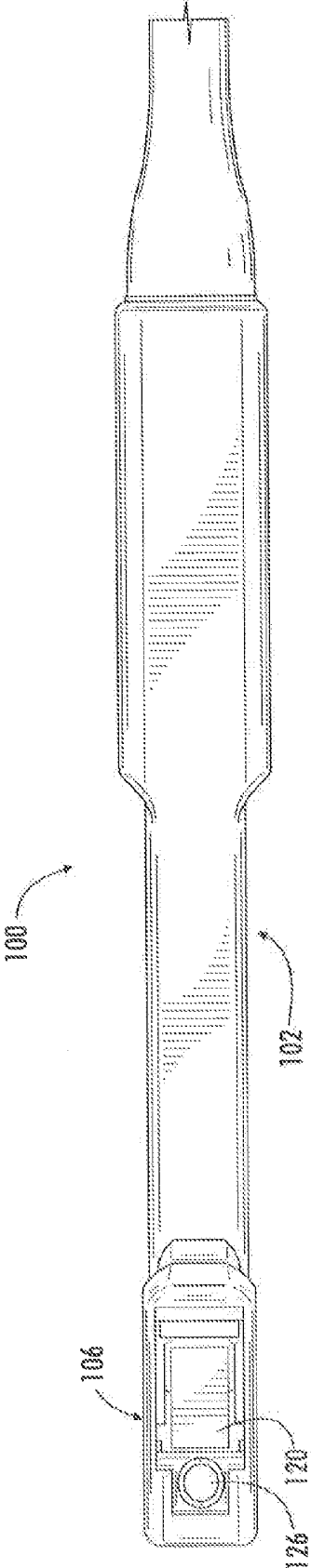

FIG. 2

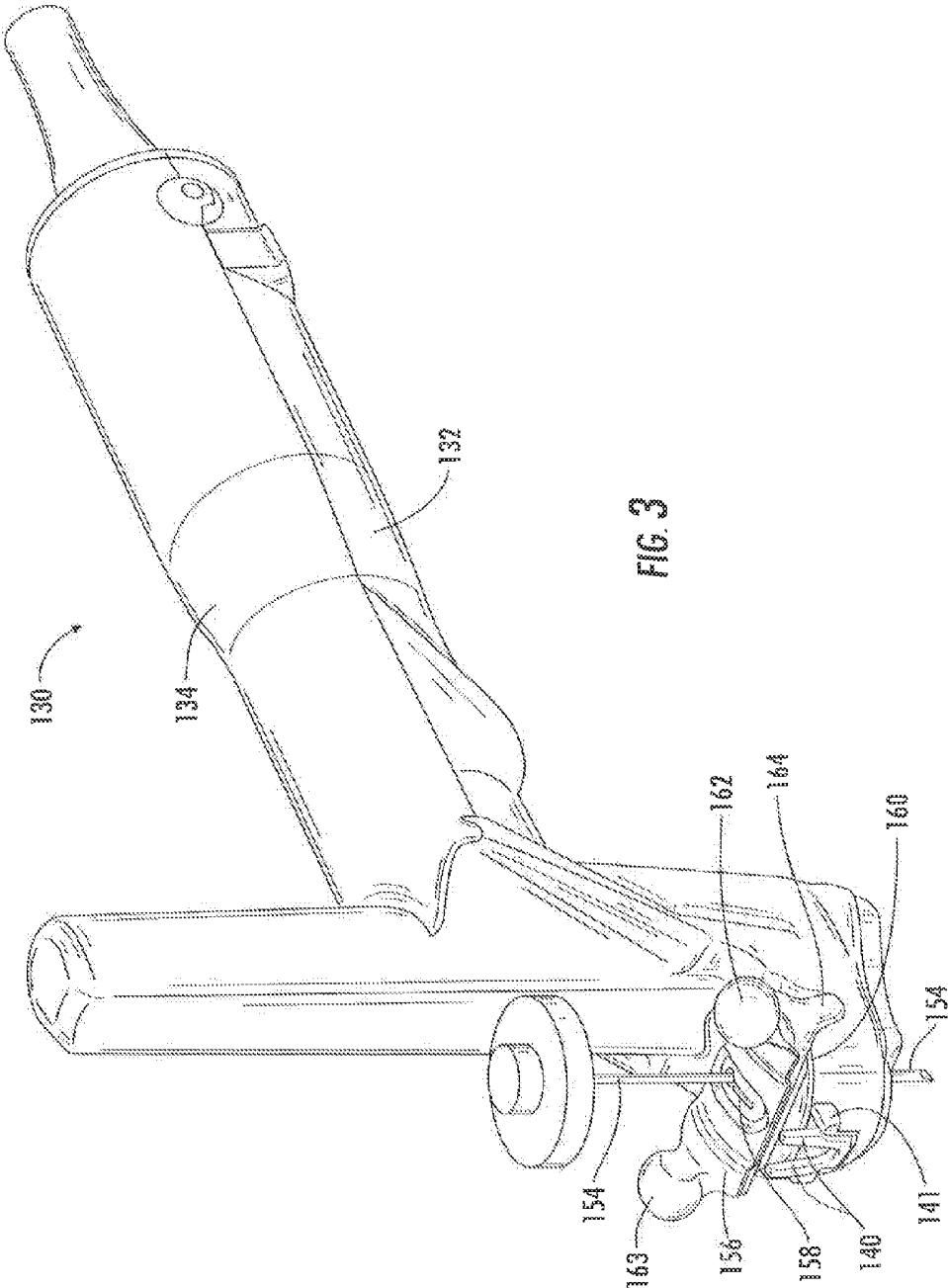
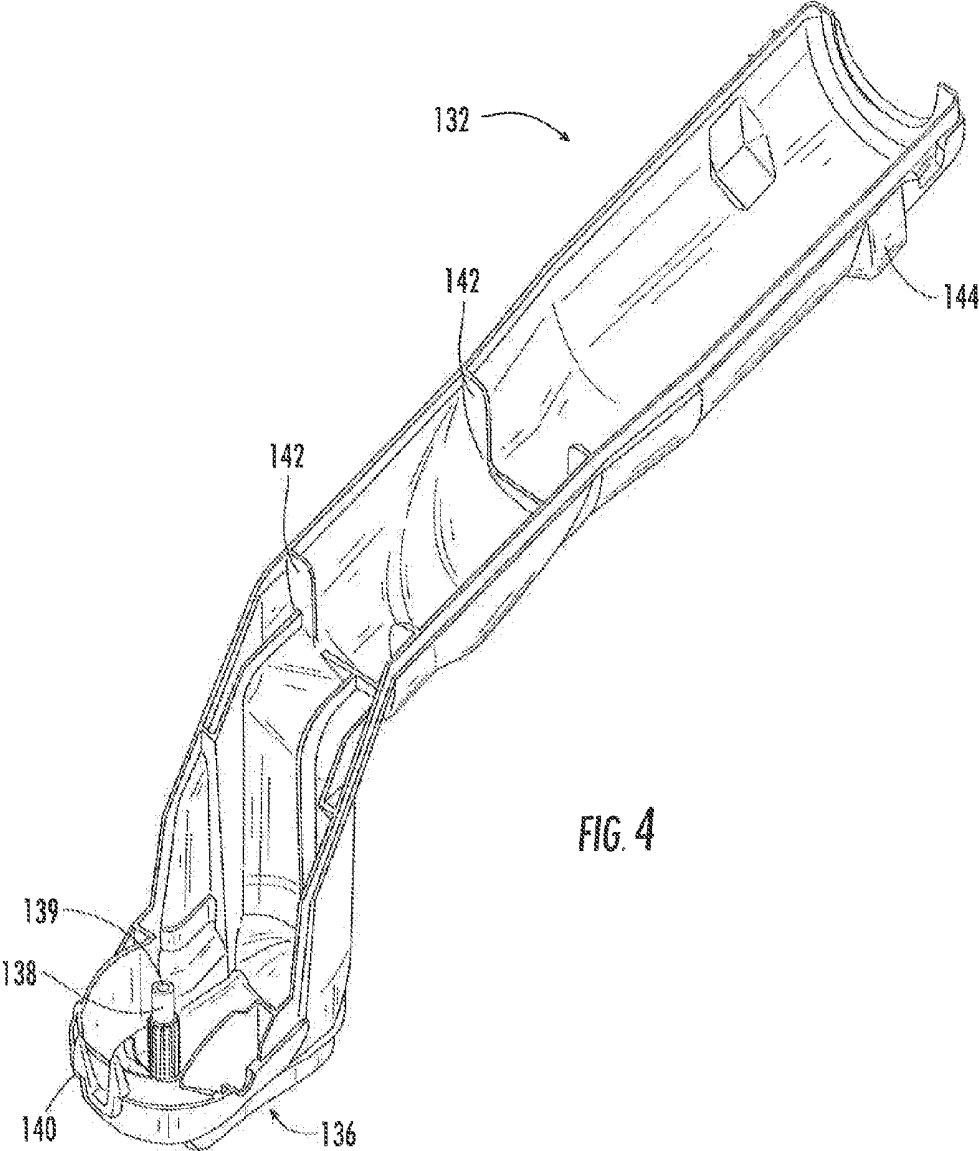
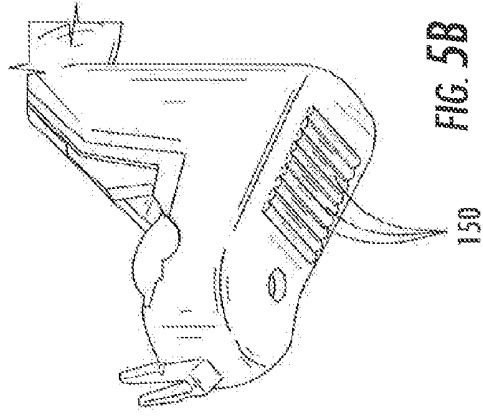
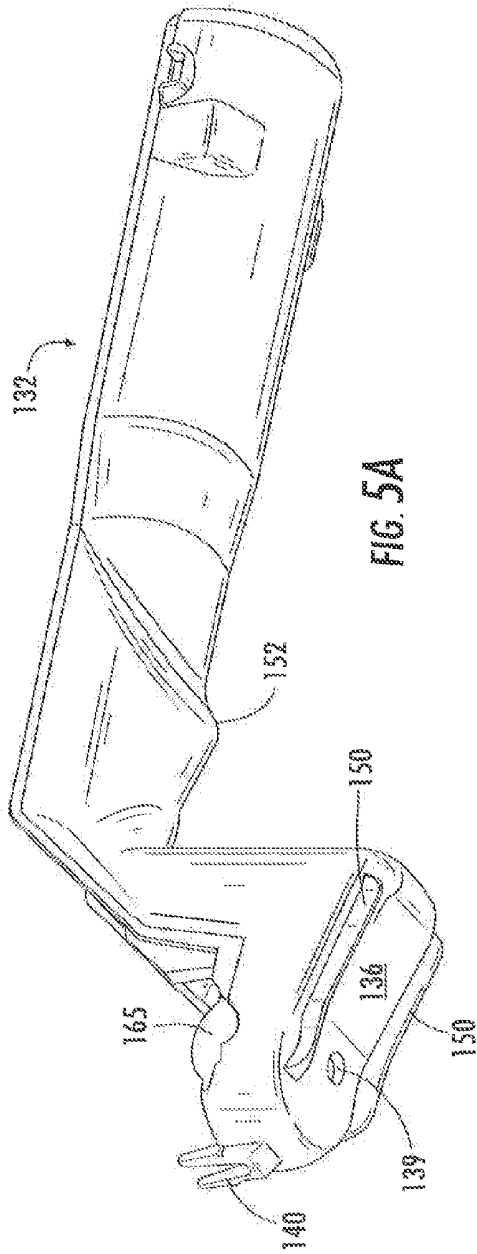

FIG. 3





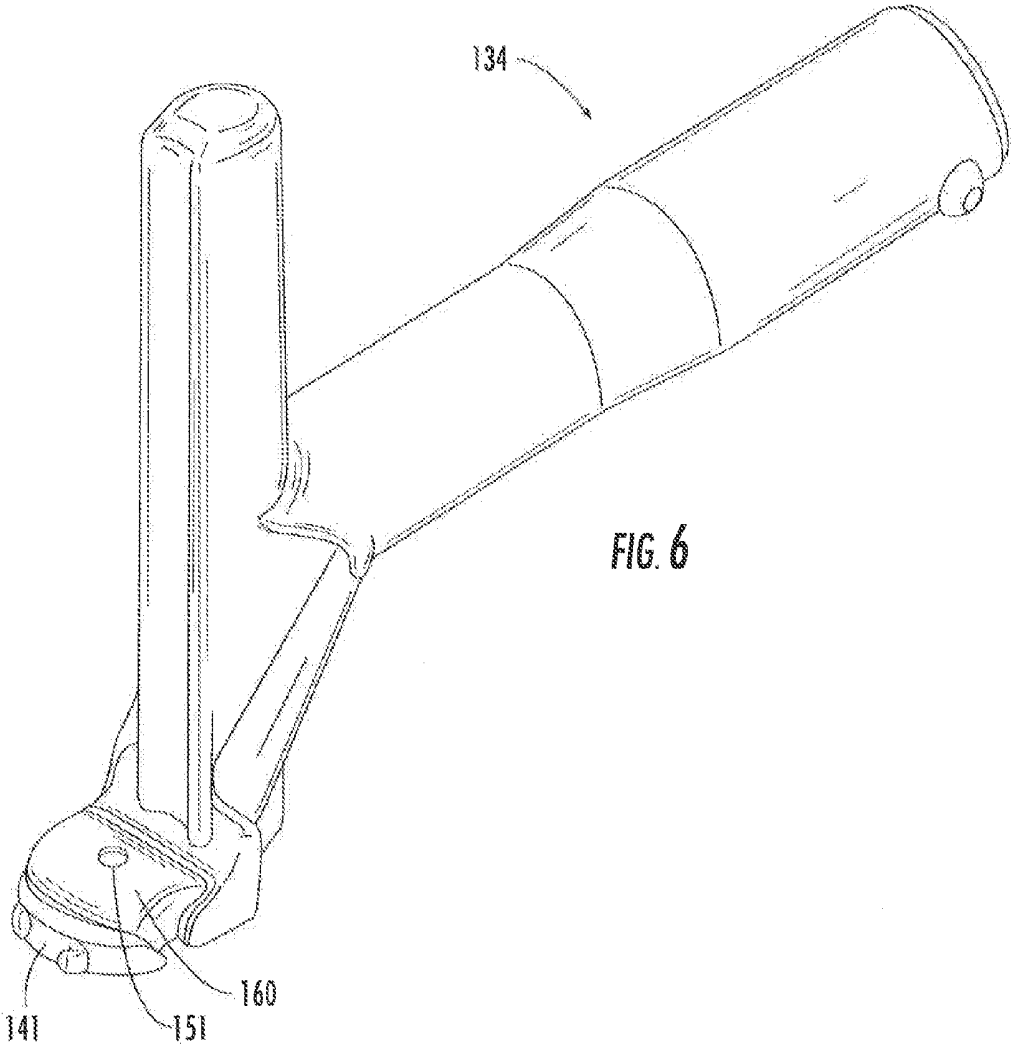

FIG. 6

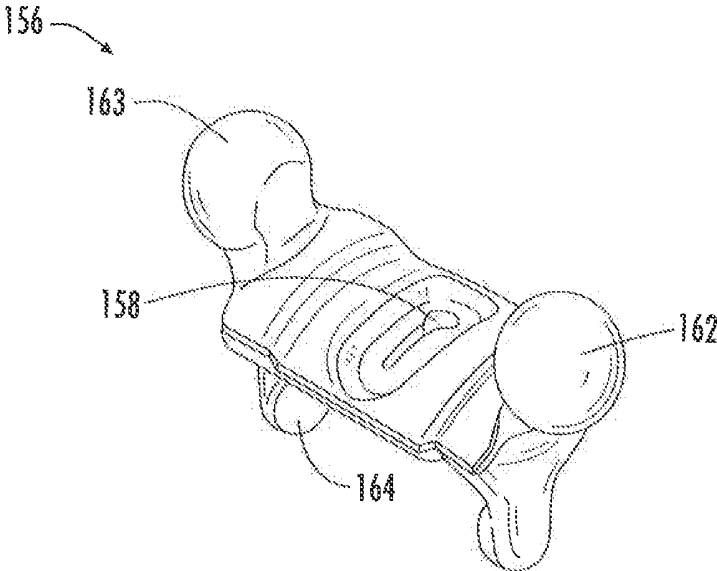

FIG. 7A

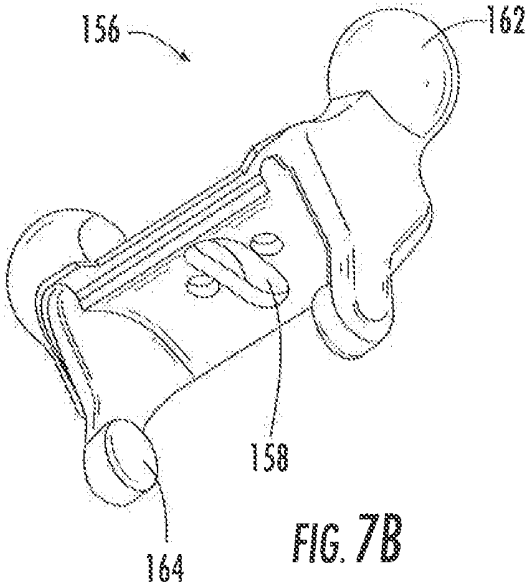

FIG. 7B

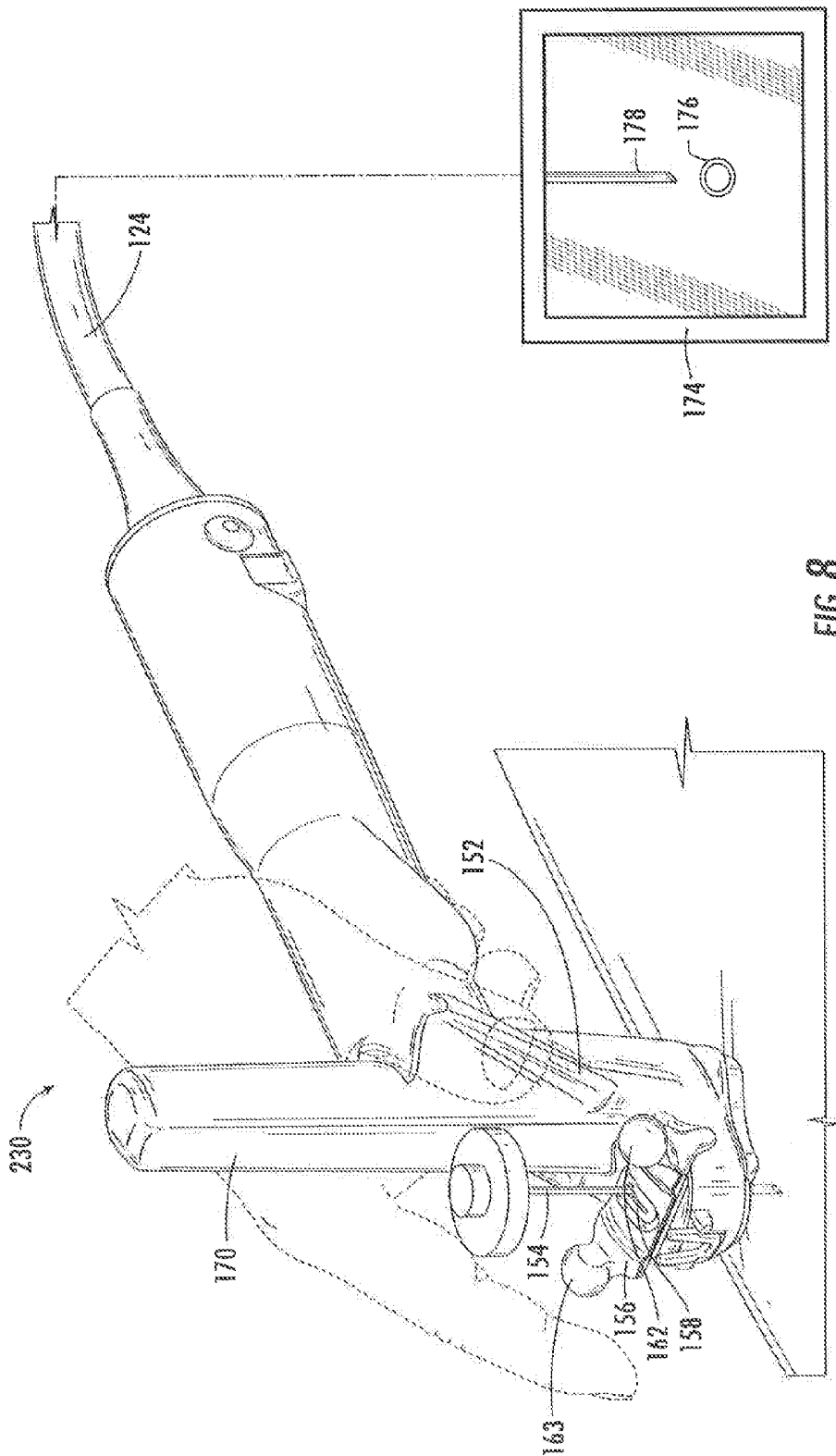
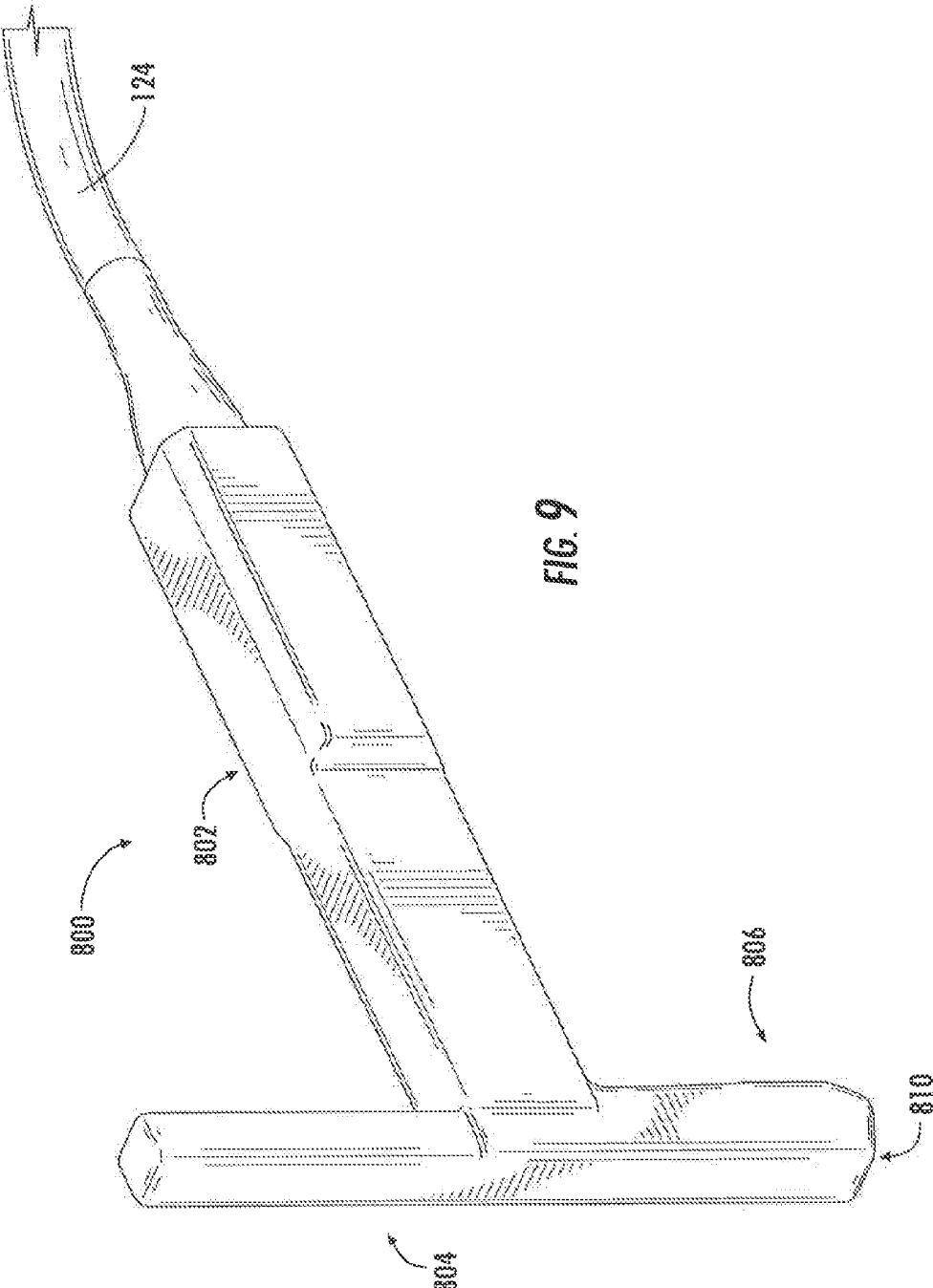
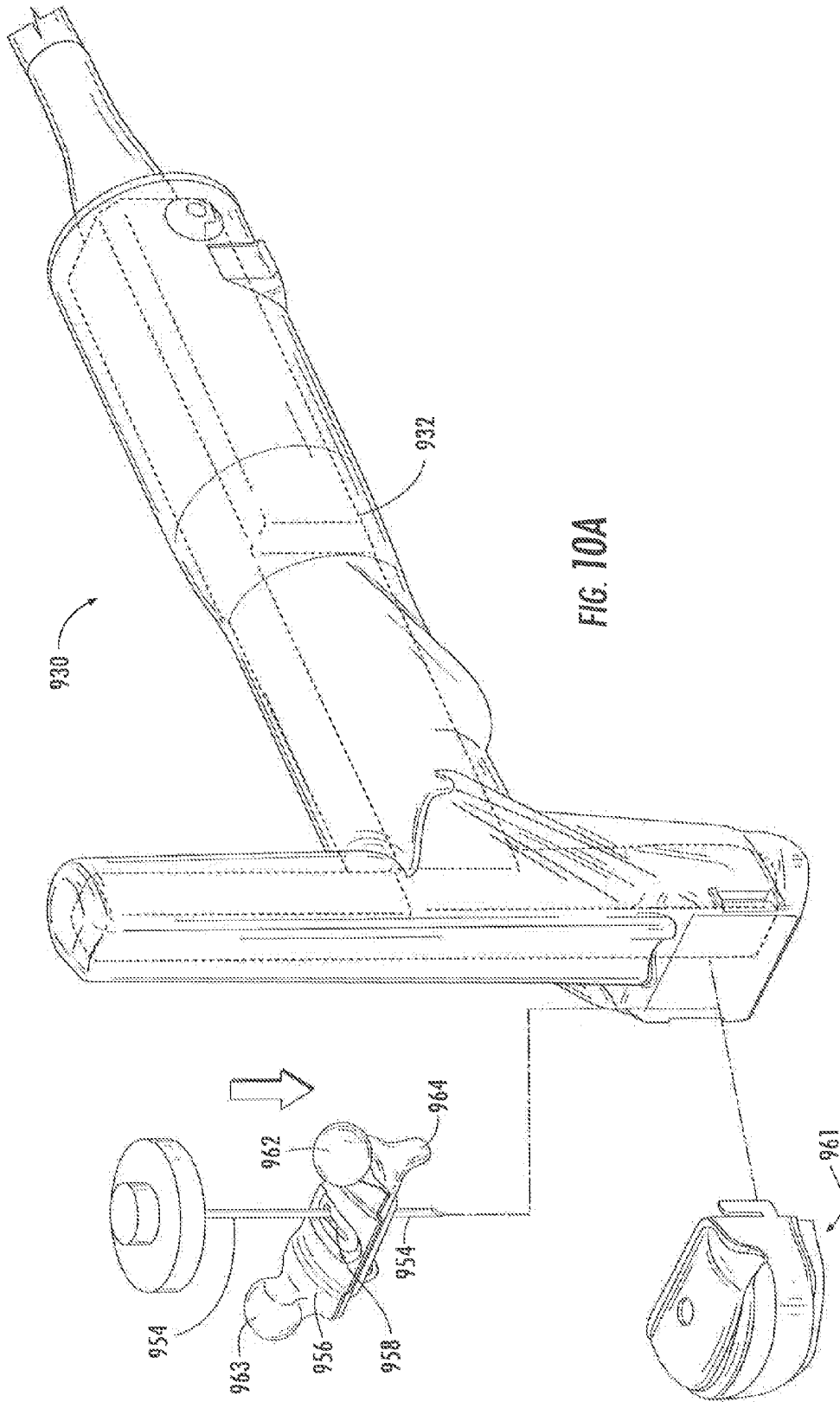
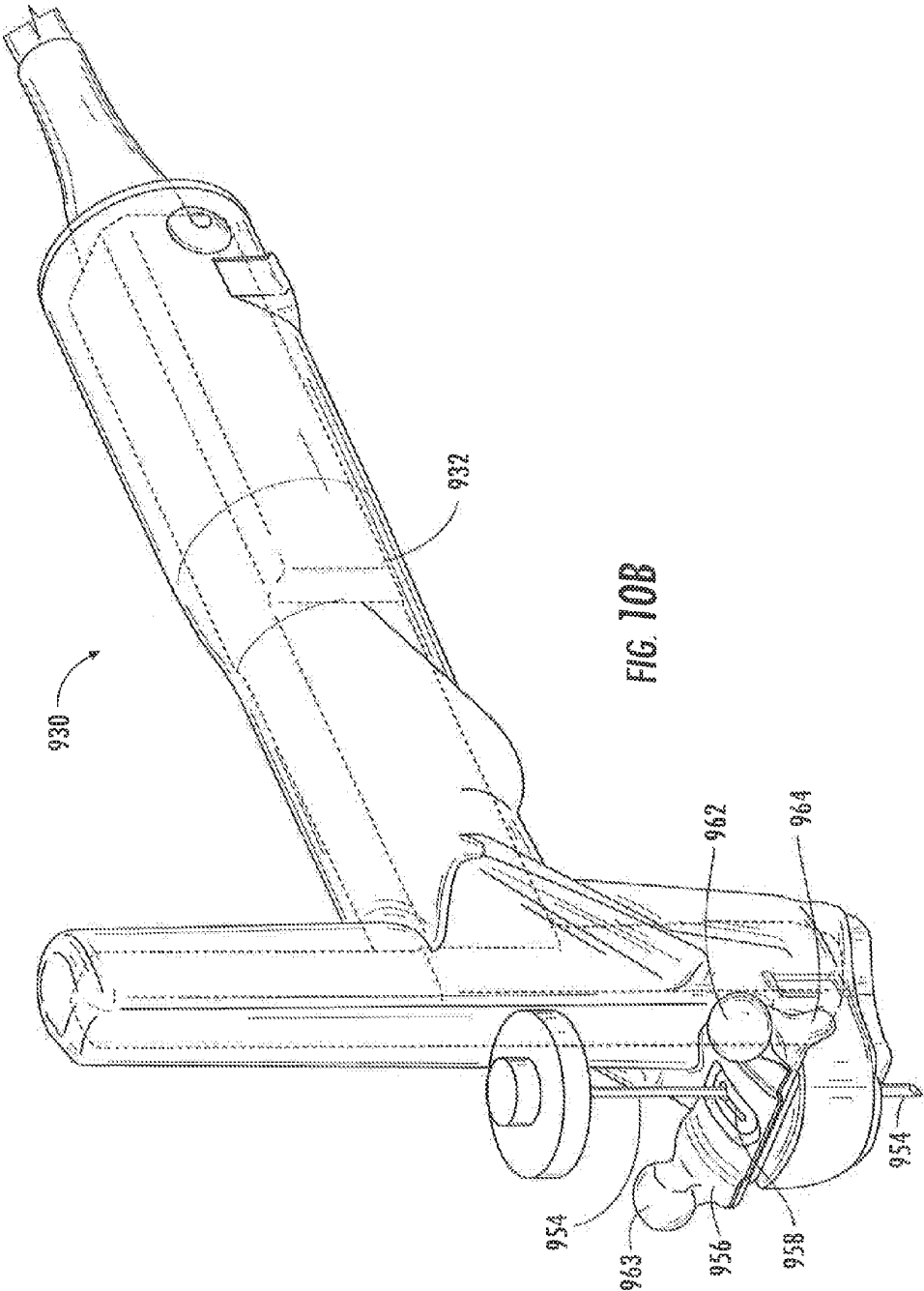

FIG. 8







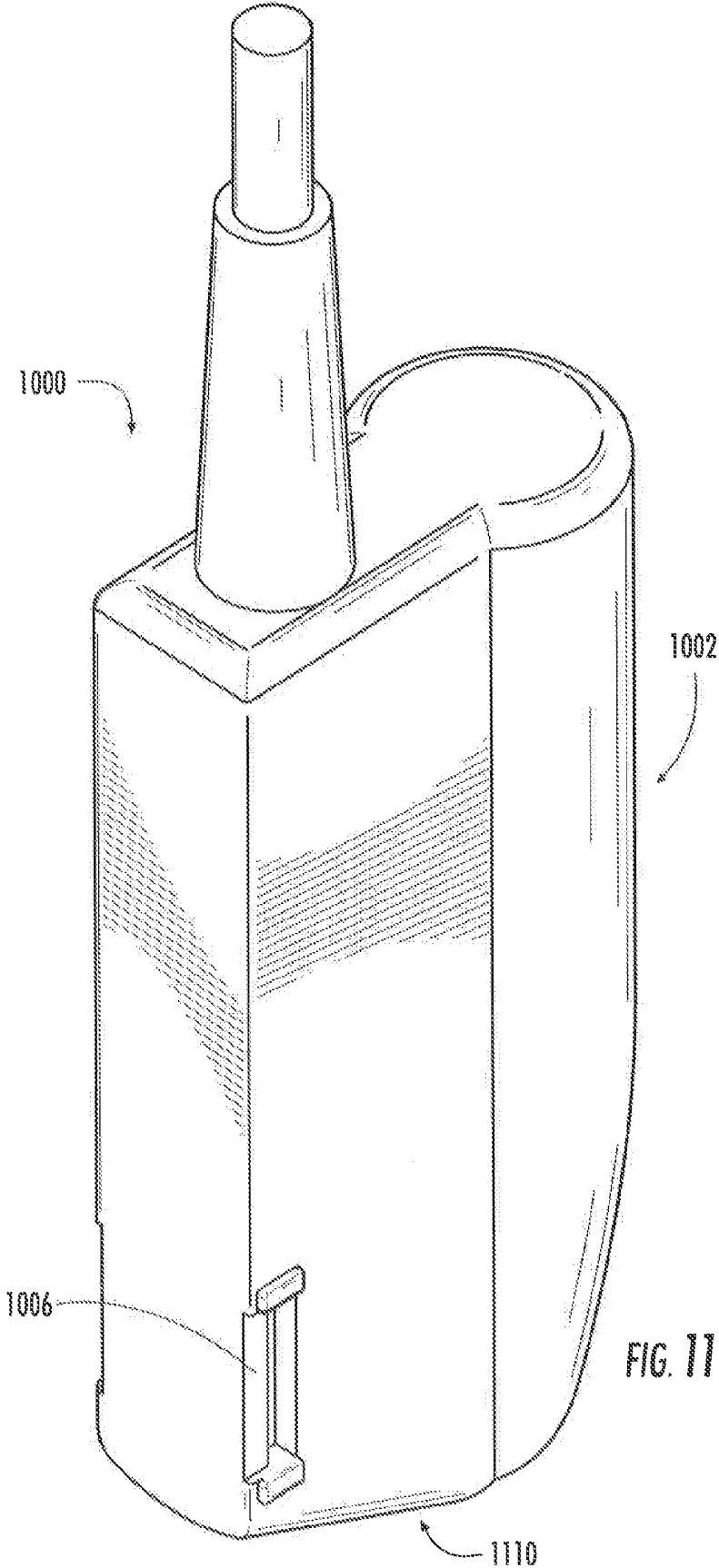

FIG. 11

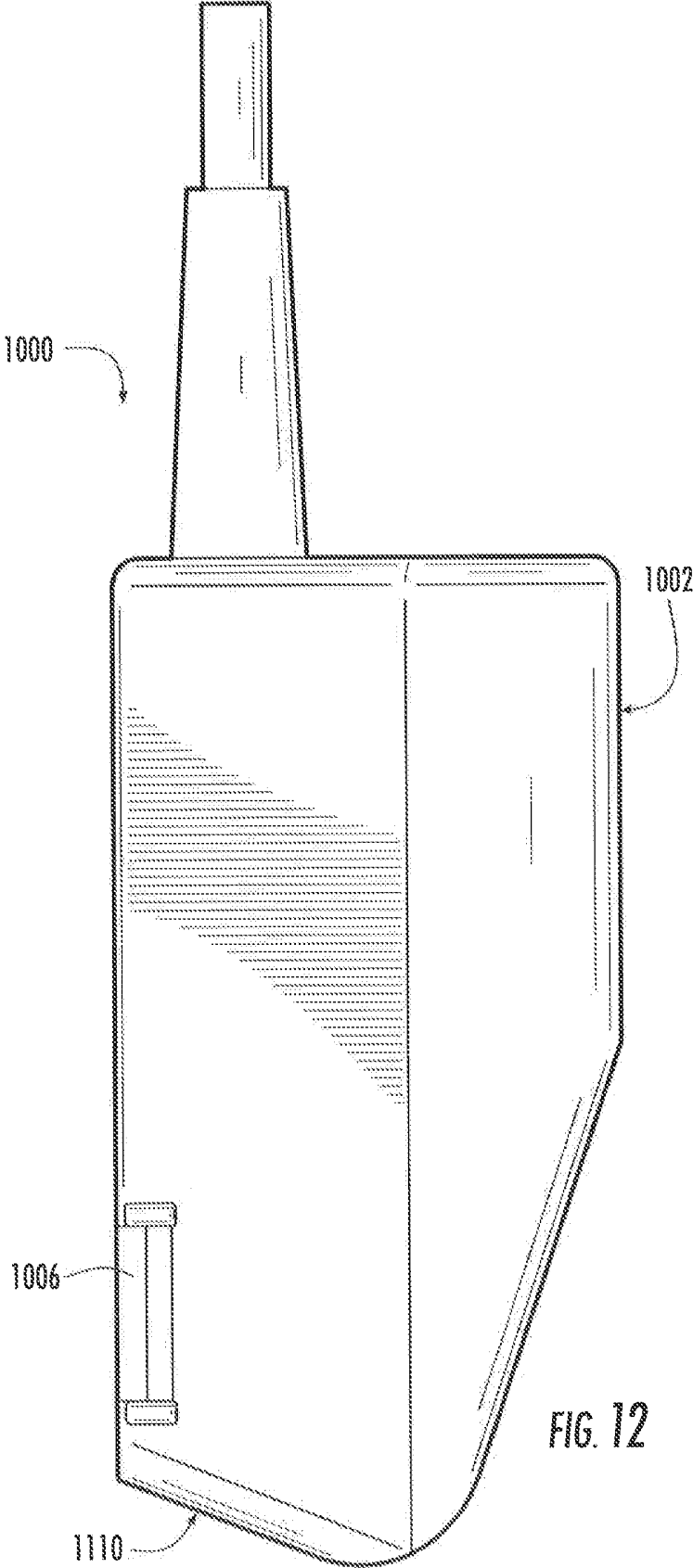
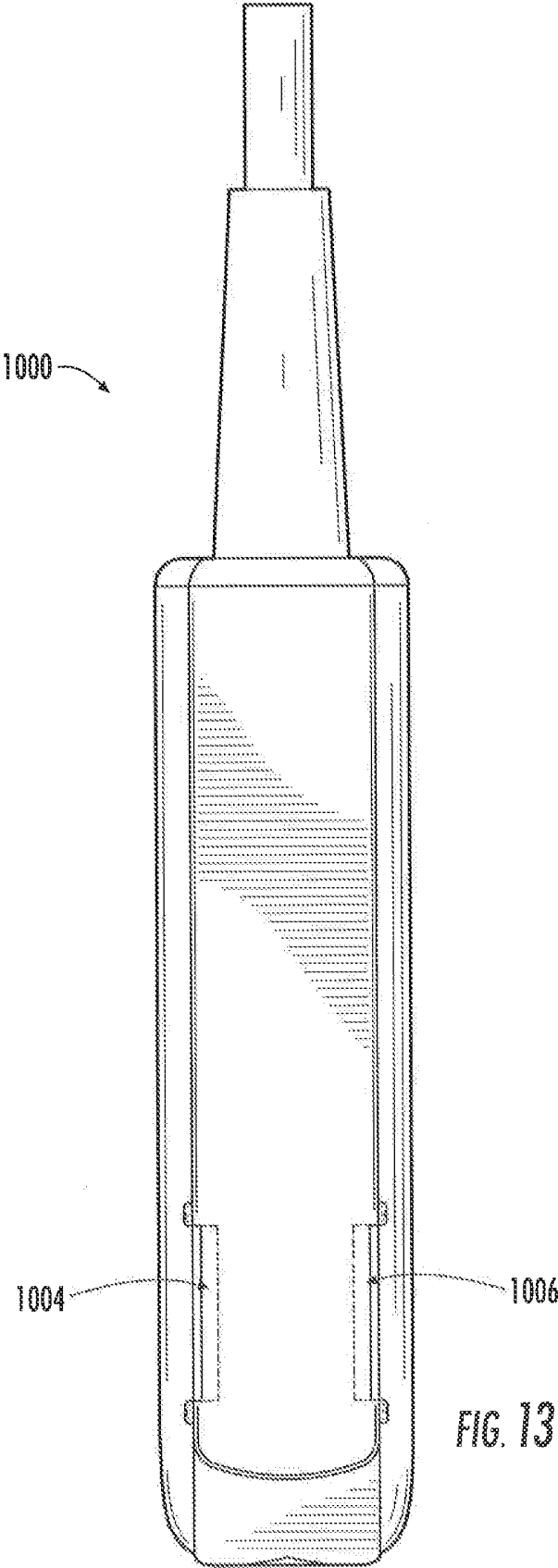

FIG. 12



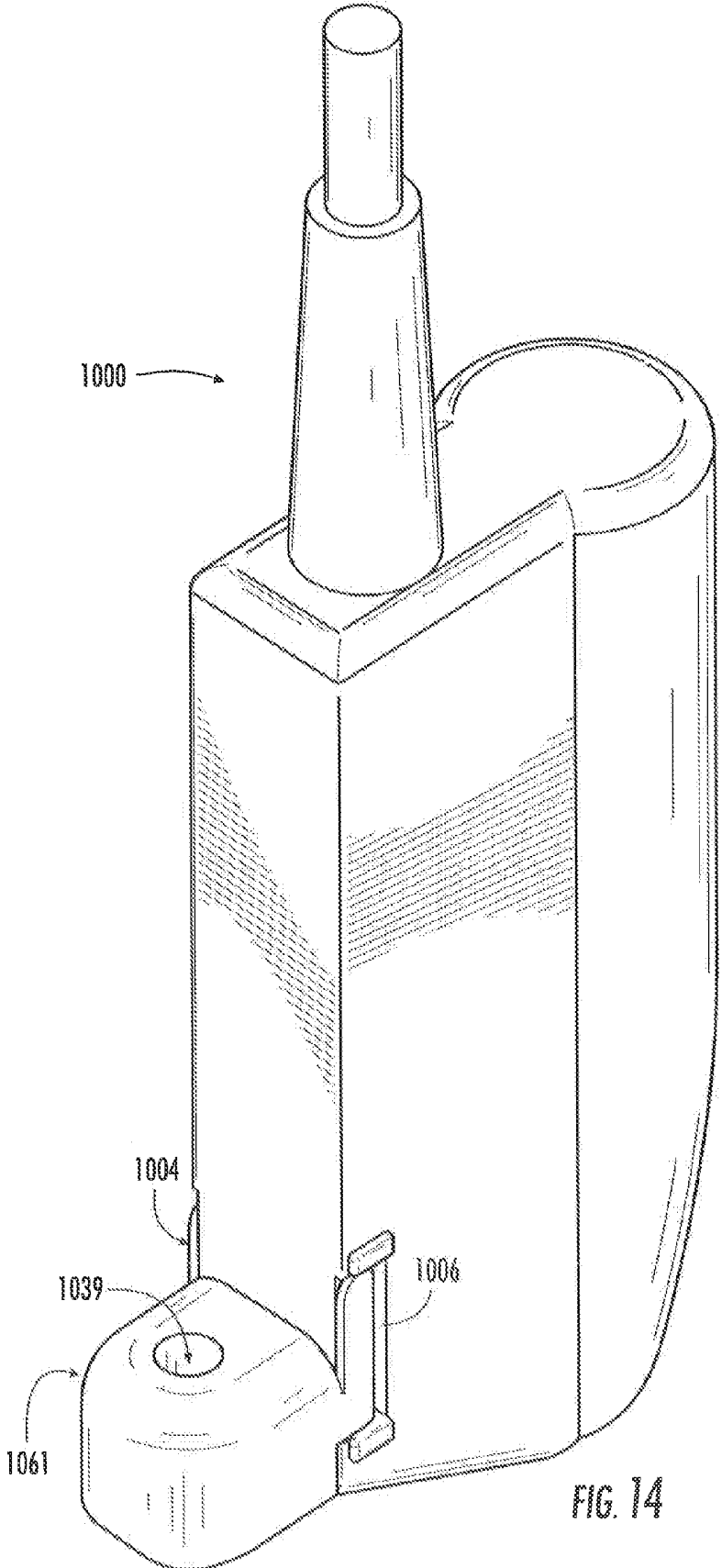

FIG. 14

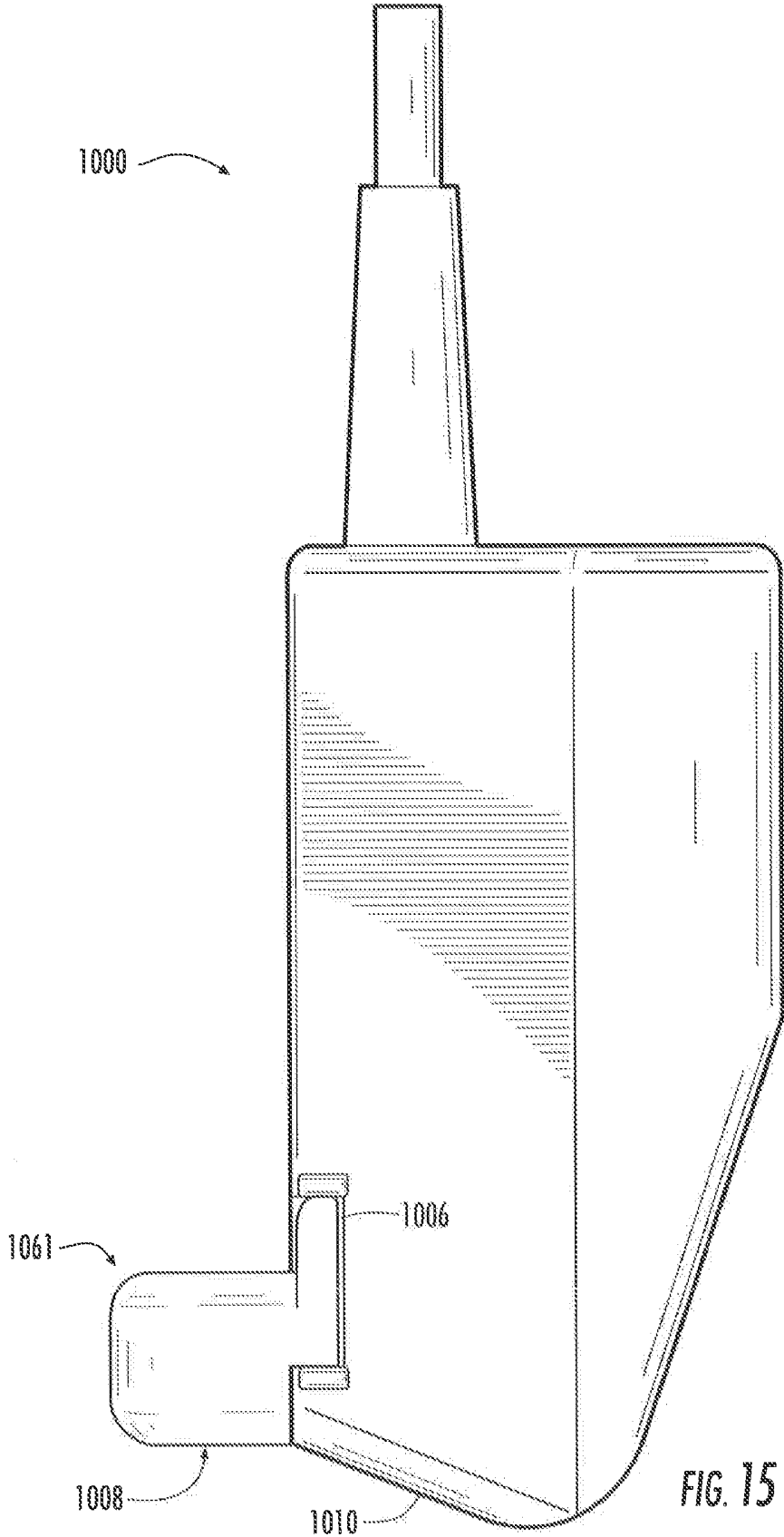

FIG. 15

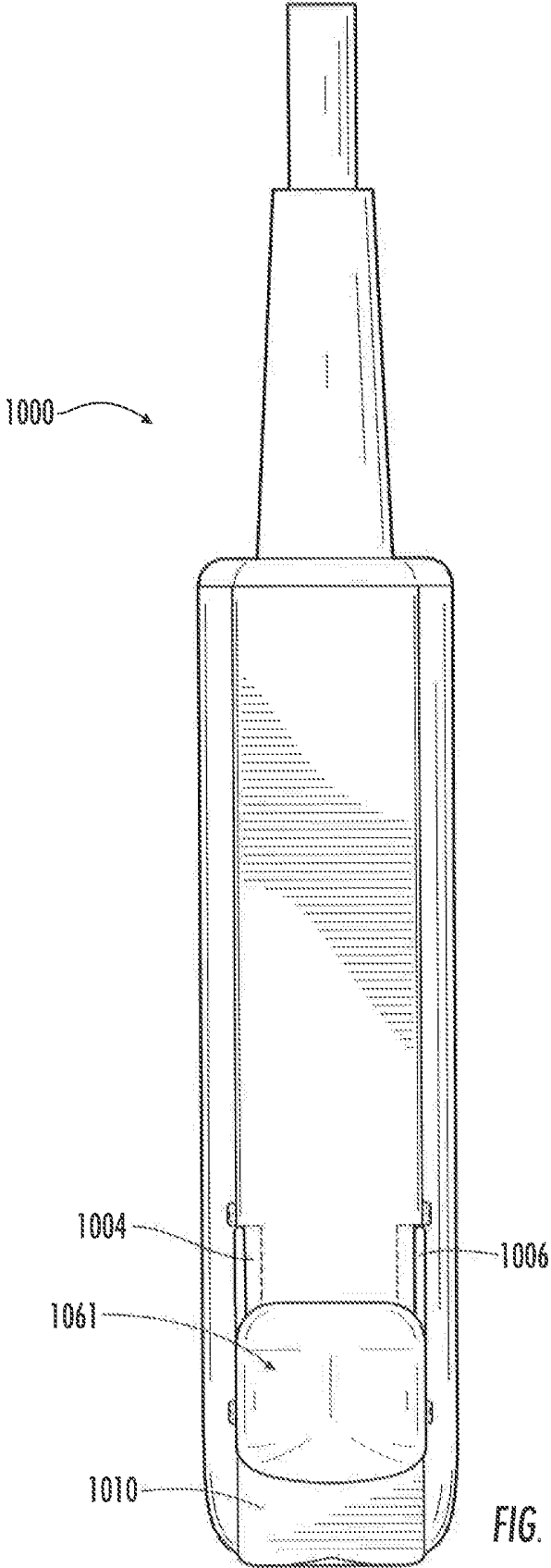
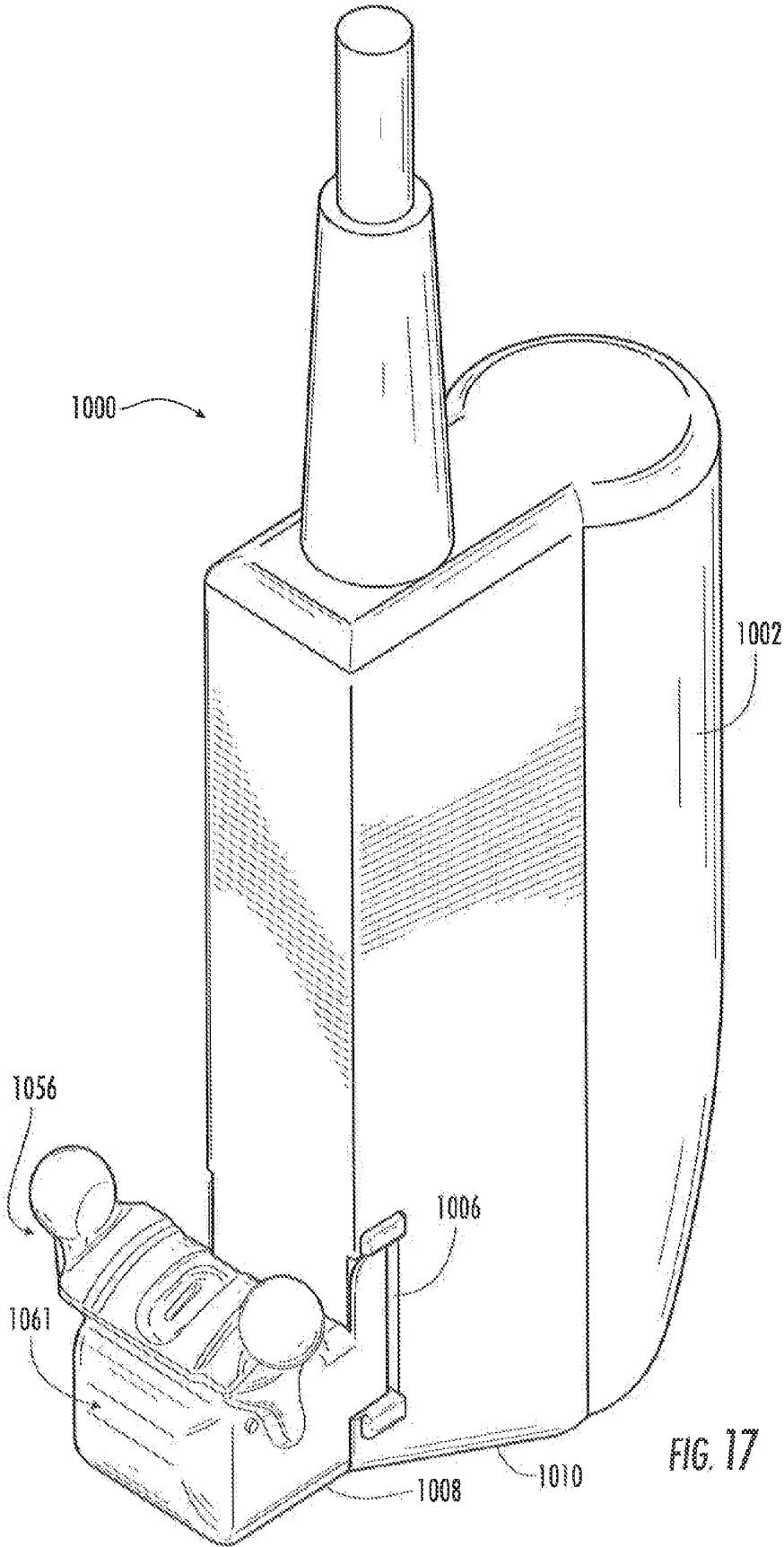

FIG. 16



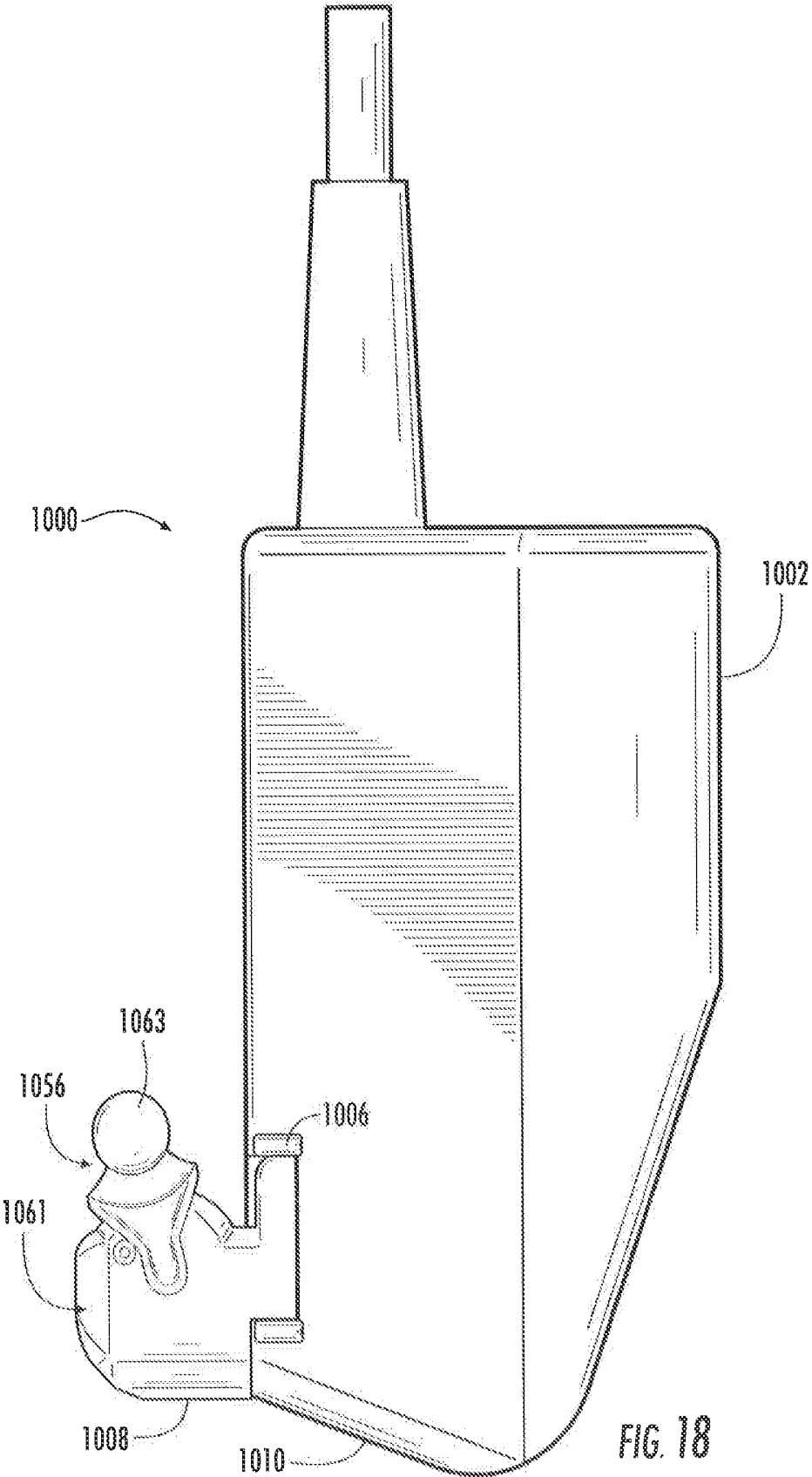

FIG. 18

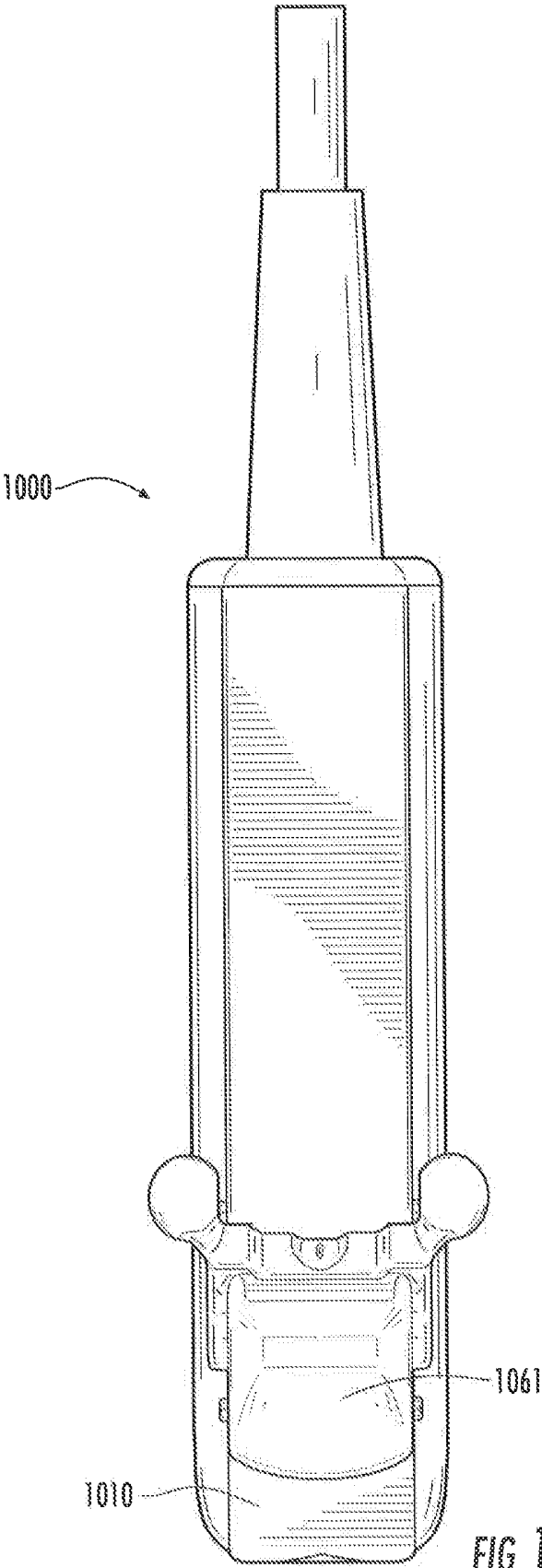

FIG. 19

**ULTRASOUND DEVICE FOR PROBE  
GUIDANCE AND STERILIZABLE SHIELD  
FOR SAME**

CROSS REFERENCE TO RELATED  
APPLICATIONS

[0001] This application is a continuing application of and claims filing priority to U.S. patent application Ser. No. 13/919,433 having a filing date of Jun. 17, 2013, which is a continuing application of and claims filing priority to U.S. patent application Ser. No. 12/576,487 having a filing date of Oct. 9, 2009, all of which are incorporated herein by reference.

BACKGROUND OF THE INVENTION

[0002] Medical probe devices are utilized for many purposes, chief of which include catheterization, centesis, and biopsy procedures. Percutaneous placement of probes using these devices is often performed with techniques which rely on ascertaining the correct locations of palpable or visible structures. This is neither a simple nor a risk-free procedure. For instance, proper insertion and placement of a percutaneous probe depends on correct localization of anatomical landmarks, proper positioning of the patient in relation to the care provider, and awareness of both the target's depth and angle from the point of probe insertion. Risks of unsuccessful placement of a probe can range from minor complications, such as patient anxiety and discomfort due to repetition of the procedure following incorrect initial placement, to severe complications, such as pneumothorax, arterial or venous laceration, or delay of delivery of life-saving fluids or medications in an emergency situation.

[0003] Ultrasound guided techniques and devices have been developed to aid in correct placement of percutaneous probes. Ultrasound guided techniques often utilize two people, an ultrasound operator who locates the internal target and keeps an image of the target centrally located on a monitor, and a care provider who attempts to guide the probe to the target based upon the sonogram. Such techniques are very difficult perceptually. For instance, these techniques are complicated by the fact that the person targeting the tissue with the probe is not the same person as is operating the ultrasound. In addition, the generally thin, cylindrical probe is usually small and reflects very little of the ultrasound beam. Moreover, as the cylindrical probe and the ultrasound beam are not generally normal to one another, the small amount of ultrasonic energy that is reflected from the probe will reflect at an angle to the incident beam, resulting in little if any of the reflected energy being detected by the ultrasound transducer. As a result, the probe itself is difficult to visualize in the sonogram and the person placing the probe must attempt to guide the probe to the correct location using minimal visual feedback. For example, the only visual feedback available is often only subtle artifacts of the motion of the probe such as slight changes in the sonogram as the probe deflects and penetrates the surrounding tissue. The trained observer can pick up subtle ultrasonic shadow artifacts deep to the probe created when the probe blocks the transmission of the ultrasound beam to the tissue below, and such subtle artifacts can be used to help guide the probe to the targeted location.

[0004] In an attempt to relieve the difficulties of ultrasound guided probe techniques, systems have been developed including a probe guide which can be attached to an ultra-

sound transducer housing. Problems still exist with such devices however. For instance, the probe guide is to one side of the ultrasound transducer housing in these devices, and the probe is often inserted at a fixed angle to the scanned plane displayed on the sonogram, restricting the intersection of the scanned plane and the point of the probe to a very small area in space. In addition, and as with hand-guided ultrasound techniques, very little, if any, ultrasonic energy is reflected from the probe back to the transducer. In fact, due to the lack of lateral motion of the probe, visual cues to the location of the probe tip may be even more difficult to discern on a sonogram when using these devices. In addition, in many of these devices, the probe passes through the ultrasound beam at a fixed depth range depending on the set angle of the probe guide, and this may not correspond to the depth of the target, in which case it may not be possible to show the juncture of the target and the probe tip on the sonogram at all.

[0005] What are needed in the art are improved ultrasound devices and methods for using such devices. For instance, what are needed in the art are ultrasound probe devices that can be utilized by a single operator to accurately visualize the delivery of a probe to a percutaneous target.

SUMMARY OF THE INVENTION

[0006] Disclosed in one embodiment is a medical probe device. The skin contacting surface can include a first portion and a second portion that are angled with respect to one another. More specifically, the first portion can define a first plane and the second portion can define a second plane, and these two planes can intersect one another to define an angle therebetween that is greater than about 150° and less than 180°. In addition, the first portion of the skin contacting surface can define a probe guide therethrough, and the second portion can be associated with an ultrasound transducer such that an ultrasonic beam transmitted from the ultrasound transducer issues from the second portion. In one embodiment, the first portion of the skin contacting surface can be defined by a first portion of the medical probe device and the second portion of the skin contacting surface can be defined by a second portion of the medical probe device, and the first and second portions of the medical probe device can be removably cooperable with one another.

[0007] The probe device can be an ultrasound transducer housing, or, in another embodiment, can include a sterilizable shield that can enclose an ultrasound transducer housing.

[0008] A probe device as disclosed herein can also include a clamp for clamping a probe in the probe guide of the device, for instance after the probe tip has reached a targeted percutaneous target.

[0009] Disclosed devices can be connectable to a monitor for displaying a sonogram. Moreover, the path of a probe guided through the probe guide can define a line that is coincident (i.e., within) the scanned plane of a sonogram formed by the ultrasound device.

[0010] A device can include a detector for detecting motion of a probe within the probe guide. Information from the detector can be processed and, in one embodiment, can be displayed as an image of a virtual probe on the monitor overlaying the sonogram, providing a real-time visualization of the location of the probe tip during a procedure.

[0011] A probe device can include additional beneficial features. For example, in one embodiment, a skin contacting surface of a probe device can include at least one raised ridge on the surface that can improve coupling between the skin and

the probe device, generally in conjunction with ultrasonic gel between the two. In another embodiment, a skin contacting surface can include a wedge formed of an ultrasonic transmissive material to improve coupling between the skin and the probe device and/or to improve visualization of percutaneous targets that are close to the surface of the skin.

[0012] Also disclosed herein is a single-use sterilizable shield as can be utilized with an ultrasound transducer. In one embodiment, a sterilizable shield can include a first section, a second section and a fastener for connecting the first section and the second section to one another. Beneficially, the fastener can be a single-use fastener that can be permanently disabled upon disconnection and separation of the first section and the second section from one another that can prevent reuse of a shield and enhance patient safety.

[0013] Also disclosed is a multi-piece device including multiple removably attachable portions. For instance, a device can include a first portion that incorporates an ultrasound transducer and a second portion that defines all or a portion of a probe guide, and the two portions can be removably attached to one another. A device can also include a detector for detecting the presence or the motion of a probe within the probe guide.

[0014] Also disclosed are methods for guiding a probe to a percutaneous target. Methods can include, for example, utilizing a probe guide including an ultrasound device with a single-use sterilizable shield and disabling the shield upon disassembly of the device. Beneficially, disclosed methods can be carried out by a single operator during a medical procedure.

#### BRIEF DESCRIPTION OF THE FIGURES

[0015] A full and enabling disclosure of the present subject matter, including the best mode thereof to one of ordinary skill in the art, is set forth more particularly in the remainder of the specification, including reference to the accompanying figures in which:

[0016] FIG. 1A illustrates one embodiment of an ultrasound device as disclosed herein;

[0017] FIG. 1B illustrates a side view of the base of the device of FIG. 1A;

[0018] FIG. 1C illustrates a side view of the base of another embodiment of an ultrasound device as disclosed herein;

[0019] FIG. 2 illustrates a bottom view of the device of FIG. 1;

[0020] FIG. 3 illustrates one embodiment of a multi-section sterilizable shield as disclosed herein;

[0021] FIG. 4 illustrates the lower section of the sterilizable shield illustrated in FIG. 3;

[0022] FIG. 5A illustrates a bottom view of the lower section of the sterilizable shield illustrated in FIG. 3;

[0023] FIG. 5B illustrates a partial bottom view of another embodiment of a sterilizable shield as disclosed herein;

[0024] FIG. 6 illustrates the upper section of the sterilizable shield illustrated in FIG. 3;

[0025] FIGS. 7A and 7B illustrate two views of the damping mechanism of the sterilizable shield of FIG. 3; and

[0026] FIG. 8 illustrates one embodiment of a method for utilizing a device as disclosed herein.

[0027] FIG. 9 illustrates an ultrasound transducer housing that can be removably attachable to a portion of a probe device defining a probe guide;

[0028] FIGS. 10A and 10B illustrate a probe device including the ultrasound transducer housing of FIG. 9 enclosed in a

sterilizable shield portion, a separable portion removably attachable thereto that defines a probe guide, and a clamp removably attachable thereto, with FIG. 10A showing the sections removed from one another and FIG. 10B showing the sections when attached together.

[0029] FIG. 11 illustrates another embodiment of a probe device as disclosed herein.

[0030] FIG. 12 is a side view of the probe device illustrated in FIG. 11.

[0031] FIG. 13 is a front view of the probe device illustrated in FIG. 11.

[0032] FIG. 14 illustrates the device of FIG. 11 including a removably attachable probe guide portion.

[0033] FIG. 15 is a side view of the device of FIG. 14.

[0034] FIG. 16 is a front view of the device of FIG. 14.

[0035] FIG. 17 illustrates the device of FIG. 14 with a clamp removably attached to the probe guide portion.

[0036] FIG. 18 is a side view of the device of FIG. 17.

[0037] FIG. 19 is a front view of the device of FIG. 17.

[0038] Repeat use of reference characters in the present specification and drawings is intended to represent the same or analogous features of elements of the disclosed subject matter. Other objects, features and aspects of the subject matter are disclosed in or are obvious from the following detailed description.

#### DETAILED DESCRIPTION OF PREFERRED EMBODIMENTS

[0039] Reference will now be made in detail to various embodiments of the disclosed subject matter, one or more examples of which are set forth below. Each embodiment is provided by way of explanation of the subject matter, not limitation of the subject matter. In fact, it will be apparent to those skilled in the art that various modifications and variations may be made in the present disclosure without departing from the scope or spirit of the subject matter. For instance, features illustrated or described as part of one embodiment, may be used in another embodiment to yield a still further embodiment. Thus, it is intended that the present disclosure cover such modifications and variations as come within the scope of the appended claims and their equivalents.

#### Definitions

[0040] As utilized herein, the term “probe” generally refers to a device that can be guided to a percutaneous location, for instance for delivery of a therapeutic, e.g., a compound or a treatment, to the location; for removal of material from the location; and so forth. For example, the term “probe” can refer to a needle, a tube, a biopsy device, or any other item that can be guided to a percutaneous location. In general, a probe can be guided by and used in conjunction with an ultrasound device as described herein.

[0041] As utilized herein, the term “probe device” generally refers to a device that can be utilized in conjunction with a probe, but does not necessarily include the probe itself.

#### Detailed Description

[0042] According to one embodiment, disclosed herein are devices and methods for use in guiding a percutaneous probe during a medical procedure. In one preferred embodiment, disclosed herein are probe devices that can include an ultrasound transducer therein. Devices can define an opening to accommodate a probe therethrough so as to improve coordi-

nation between a sonogram formed by the ultrasound device and the path of a probe passing through the opening. In one embodiment, disclosed devices can include a visualization system so as to provide a real-time image of a virtual probe on a sonogram and improve delivery of a probe to a percutaneous target.

**[0043]** Also disclosed herein are sterilizable shields that can surround all or a portion of an ultrasound transducer to form a sterilizable probe device. Thus, disclosed probe devices can be utilized in an ultrasound guided medical procedure that requires a sterile field to ensure the safety of a patient. For instance, disclosed devices can be used in a central venous catheterization procedure, in a biopsy procedure, and the like.

**[0044]** Beneficially, disclosed devices can be formed so as to conveniently be utilized by a single operator who can control an ultrasound transducer and also deliver a probe using the probe guidance system. Disclosed devices can include a variety of other beneficial features as well. For example, features of disclosed devices can improve contact and gel coupling between a skin surface and the surface of a device, can improve the effective field of the sonogram formed with the ultrasound transducer, and can prevent non-sterile use of a sterilizable shield of a device, all of which are described in greater detail herein.

**[0045]** In one preferred embodiment, disclosed devices can incorporate a system that can be used to visualize a percutaneous probe as it is being guided with a device. One preferred embodiment of a visualization system as may be incorporated with disclosed devices has been described in U.S. Pat. No. 7,244,234 to Ridley, et al., which is incorporated herein by reference. Through utilization of a visualization system, the path of a probe guided with a device and hence the location of the probe tip can be more clearly known in relation to a target imaged by the ultrasound device.

**[0046]** In accord with the present disclosure, FIG. 1A illustrates one embodiment of an ultrasound transducer housing generally **100**. Transducer housing **100** includes handle **102**, post **104**, and base **106**. FIG. 2 provides a bottom view of the transducer housing **100**. An ultrasound transducer **120** that transmits and receives ultrasonic waves can be located in base **106**, as shown. Ultrasound transducer housing **100** can be formed of any suitable materials. For instance, any moldable polymeric material that can securely encase the ultrasound transducer **120** as well as contain associated electronics, wiring, switches, and the like and will not interfere with the functioning of the transducer **120** can be utilized.

**[0047]** Any type of ultrasound transducer as is generally known in the art can be incorporated in transducer housing **100**. By way of example, a piezoelectric transducer formed of one or more piezoelectric crystalline materials arranged in a two or three-dimensional array can be utilized. Such materials generally include ferroelectric piezoceramic crystalline materials such as lead zirconate titanate (PZT). In one embodiment, the elements that form the array can be individual electrode or electrode segments mounted on a single piezoelectric substrate, such as those described in U.S. Pat. No. 5,291,090 to Dias, which is incorporated herein by reference thereto.

**[0048]** In general, an ultrasound transducer **120** can be formed of multiple elements; however, single crystal devices are also encompassed by the present disclosure. The use of a multiple element ultrasound transducer can be advantageous in certain embodiments, as the individual elements that make

up the array can be controlled so as to limit or prevent any break or edge effects in the sonogram. For instance, the firing sequence of individual crystals can be manipulated through various control systems and prevent any possible 'blind spots' in the sonogram as well as to clarify the edges of individual biological structures in the sonogram. Such control systems are generally known in the art and thus will not be described in detail.

**[0049]** Referring again to FIG. 1A, ultrasound transducer housing **100** defines a probe guide opening **126** that passes through base **106**. As can be seen in FIG. 2, probe guide opening **126** can be aligned with transducer **120**. A probe that is guided through the probe guide opening **126** can travel on a path that is generally parallel to the scanned plane of a sonogram formed by use of the ultrasound device. In general, the scanned plane (i.e., the plane of the sonogram) is the geometric central plane of the beam transmitted from the ultrasound transducer **120**. In one preferred embodiment, the path of a probe guided through probe guide opening **126** can be within the scanned plane. This is not a requirement of the present disclosure, however. For instance, the path of a probe passing through probe guide opening **126** can be at an angle to the scanned plane such that it intersects the scanned plane at a point. By way of example, the line defined by the path of a probe passing through the probe guide opening **126** can be at an angle of  $\pm 1^\circ$  of the scanned plane, or at a greater angle, in another embodiment. For instance, a line defined by the path of a probe passing through the probe guide opening **126** can be at an angle of  $\pm 10^\circ$ ,  $\pm 20^\circ$ ,  $\pm 45^\circ$ , or even greater, in other embodiments.

**[0050]** Generally, ultrasound transducer **120** can be connected via signal wires in a cable **124** that leads to a processor that processes the data to form a sonogram on a monitor, as is generally known in the art. In the particular embodiment as illustrated in FIG. 1A, cable **124** is internal to handle **102** of the ultrasound transducer housing **100**, though this particular arrangement is not a requirement of the disclosure. Handle **102** can generally be set at an angle to post **104** of transducer housing **100** so as to be comfortably held in the hand while the device is being utilized. For instance, in the illustrated embodiment, handle **102** is about  $90^\circ$  to post **104**, though this angle can be varied as desired. Moreover, in another embodiment described further herein, a device need not include an extending handle portion at all.

**[0051]** Referring to FIG. 1B, base **106** defines a lower surface **108** defining probe guide opening **126** and lower surface **110** from which an ultrasonic beam emitted by transducer **120** can issue. Surfaces **108** and **110** together can form a skin contacting surface on the base **106** of the device **100**. As can be seen, surfaces **108** and **110** are contiguous and angled with respect to one another. The angle between surface **108** and **110** can vary. For instance, in one embodiment the angle marked as  $\theta$  in FIG. 1B can vary from  $0$  to about  $30^\circ$  or from about  $10^\circ$  to about  $20^\circ$  in another embodiment. Accordingly, the angle between surfaces **108** and **110** can be greater than about  $150^\circ$  and less than  $180^\circ$  in one embodiment, or greater than about  $160^\circ$  and less than about  $170^\circ$  in another embodiment.

**[0052]** It has been found that such geometry can be beneficial in certain embodiments. For instance, referring to FIG. 1B, base **106** is illustrated with the edges of a scanned plane formed by ultrasound transducer **120** shown within broken lines **4** and **6**. The distance **8** from the termination of probe guide opening **126** to the edge **4** of the scanned plane is also

shown. During use, the portion of base **106** including surface **110** can press into the skin of a subject somewhat and ensure good contact between the ultrasound transducer **120**, ultrasonic gel, and the skin. Upon passing a probe through the probe guide opening **26**, the probe will contact the skin and travel the short percutaneous distance **8** before entering the ultrasound beam. The distance **8** can depend upon the angle between the surfaces **108** and **110**, but can be relatively small. For instance, distance **8** can be less than about 25 mm, less than about 10 mm, less than about 5 mm or less than about 1 mm.

[0053] In comparison, FIG. 1C illustrates a base **205** in which the entire bottom edge of base **205** is planar, i.e., the skin contacting surface of base **205** does not include angled portions. FIG. 1C also illustrates the edges of a scanned plane formed by transducer **120** by use of broken lines **204** and **206**. As can be seen, the distance **208** between the point a probe will exit probe guide opening **226** and enter the scanned plane at **204** is greater than the distance **8** in the embodiment in FIG. 1B. An embodiment including a base that defines an angled bottom surface, as is illustrated in FIG. 1B may be preferred in those embodiments in which a percutaneous target may be close to the skin surface.

[0054] It should also be understood that while the skin contacting surface and portions thereof of the illustrated probe devices are generally planar, this is not a requirement of the disclosed subject matter. For instance, with regard to FIG. 1B, surface **108** and/or surface **110** can be curved, e.g., can define an arcuate profile along either or both of the axes of the surface. In this embodiment, a curved surface can define a plane between the intersection line of two portions (e.g., surface **108** and surface **110**) forming the skin contacting surface and a point at the outer edge of the curved surface. Planes defined by a curved skin contacting surface can correspond in a like manner to a planar skin contacting surface (or portions thereof) as described above.

[0055] In another embodiment, the skin contacting surface of a device can be associated with a removably cooperable material so as to encourage improved imaging of a percutaneous location. For instance, a planar skin contacting surface, such as is illustrated in FIG. 1C, or a portion of an angled skin contacting surface, such as surface **108** of FIG. 1B, can be associated with an ultrasound transmissive wedge formed of an ultrasonic transmissive material so as to alter the relative orientation between the skin surface and an ultrasound device. For instance a pliable saline-filled container can be held against or attached to the base of surface **108** to alter the relative orientation of the surfaces. Such a device can be utilized to, e.g., more clearly visualize percutaneous targets that are close to the skin surface. An ultrasound transmissive wedge can be located on the skin contacting surface of a device utilizing a small amount of ultrasonic gel for a temporary attachment, or utilizing a biocompatible adhesive for a more permanent attachment, or by any other suitable adherence method.

[0056] It should be understood that any particular geometric configuration for transducer housing **100** and its individual sections is not essential to the present invention. For example, the base **106** of transducer housing **100** may be oblong, square, round, rectangular or any other suitable shape. In certain embodiments, the shape of ultrasound housing **100** may be particularly designed to fit specific locations of the anatomy. For example, ultrasound housing **100** may be shaped to be utilized specifically for infraclavicular approach

to the subclavian vein, approach to the internal jugular vein, specific biopsy procedures including, without limitation, breast biopsy, thyroid nodule biopsy, prostate biopsy, lymph node biopsy, and so forth, or some other specific use. Variations in shape for any particular application can include, for example, a specific geometry for the footprint of base **106**, alteration in the size of post **104** and/or handle **102**, as well as variation in angles at which various elements of a device meet each other, such as the angle defined by the bottom of base **106** previously discussed. For example, the footprint of base **106** can be any suitable shape and size, e.g., rectangular, round, oblong, triangular, etc. By way of example, the skin contacting surface of base **106** can be between about 0.5 inches and about 6 inches on its greatest length. In one embodiment, the footprint of base **106** can be about 0.5 inches on its greatest width so as to promote stability of the device during use. In other embodiments, it can be larger, however, such as about 1 inch on its greatest width, about 2 inches on its greatest width, or even larger.

[0057] Transducer housing **100** can be used as is, with no additional shield or covering over the housing **100**. According to this embodiment, a probe, e.g., a needle, can pass through probe guide opening **126** and can be directed to a target that is visualized on a sonogram formed by use of ultrasound transducer **120**. According to another embodiment, however, all or a portion of transducer housing **100** can be encased in a sterilizable shield, for instance in those embodiments in which a probe is intended for use in a sterile field. According to this embodiment, a transducer housing can be encased in a sterilizable shield that can provide a sterile barrier between a patient and the ultrasound transducer housing **100** during a medical procedure.

[0058] A sterilizable shield can generally be formed of a number of different sterilizable, biocompatible materials. For instance, a sterilizable shield can be formed of relatively inexpensive single-use materials that can be sterilized as are generally known in the art such that the entire shield can be properly disposed of following use. In another embodiment, a sterilizable shield can be utilized multiple times, in which case it can be formed of a material that can be properly sterilized between uses. By way of example, a sterilizable shield can be formed of a moldable or extrudable thermoplastic or thermoset polymeric material including, without limitation, polyethylene, polypropylene, polymethylpentene (TPX), polyester, polyvinyl chloride, polycarbonate, polystyrene, and so forth.

[0059] FIG. 3 illustrates one example of a sterilizable shield **130** as may be utilized to encase ultrasound transducer housing **100**. Sterilizable shield **130** can include a lower section **132**, details of various embodiments of which are shown in FIG. 4 and FIG. 5, and an upper section **134**, details of which are shown in FIG. 6.

[0060] With reference to FIG. 4, shield section **132** can include a base **136** formed of an ultrasonic transmissive material. Base **136** can be of any suitable size and shape, but formed such that ultrasound transducer housing base **106** may be seated firmly in shield base **136**. Generally, a small amount of an ultrasonic gel can be placed between the bottom surface of transducer housing base **106** and shield base **136** during seating to prevent any air between the two and promote transmission of ultrasonic waves.

[0061] Arising out of shield base **136** is guide post **138**. Guide post **138** defines at least a portion of a probe guide **139** therethrough. Probe guide **139** extends uninterrupted com-

pletely through both guide post **138** and shield base **136**. Guide post **138** can include tabs as shown, or other formations such as hooks, insets, or the like that can be utilized to properly assemble shield base **136** about ultrasound transducer housing **100**. In one embodiment, guide post **138** may include a removable cap (not shown) for protection of the interior sterile surface of probe guide **139** during assembly of shield **130** with ultrasound transducer housing **100**.

[0062] As can be seen, shield section **132** can also include tabs **140**, **142**, **144**, etc. that can be utilized in properly seating ultrasound housing **100** within shield **130** as well as aligning shield section **132** with shield section **134** when assembling the complete shield **130** about an ultrasound transducer housing **100**.

[0063] In the illustrated embodiment, tabs **140** on shield section **132** match corresponding notch **141** on shield section **134** shown in FIG. 6. Together tabs **140** and notch **141** form a fastener that can secure shield section **132** and shield section **134** to one another. During assembly, tabs **140** can snap into notch **141** to securely fasten the two sections together and prevent separation of the sections **132**, **134** during use. Of course, a shield can include additional fasteners at other locations between the two sections, or can include a single fastener at an alternative location, as would be known to one of skill in the art.

[0064] In order to disassemble shield **130**, tabs **140** can be simply pinched together and slid out of notch **141**. In another embodiment, a single-use fastening mechanism can be employed to secure sections of a sterilizable shield to one another. According to this embodiment, in order to disassemble a shield following use, the tabs of the fastener can be permanently disabled. For instance, tabs **140** and/or notch **141** can be permanently broken away from the shield by a pulling or twisting motion, allowing the shield sections to come apart and also ensuring that the shield, which is no longer sterile, cannot be utilized again. Any method that can ensure that a fastener can only be utilized a single time may alternatively be utilized.

[0065] Referring to FIG. 5A, the bottom of shield section **132** can be seen. The bottom surface of base **136** of section **132** includes a series of ridges **150** running along a portion of base **136**. It has been found that inclusion of such ridges on the skin-contacting surface of a device can provide benefits to disclosed devices and methods. For instance, the inclusion of ridges on the skin contacting surface can push and better hold ultrasonic gel between the device and the skin surface, preventing formation of an air gap between the two and improving coupling between a subject's skin and the device. In addition, ridges along the skin contacting surface can also add an extra pushing force against the skin itself, better holding the skin tightly against the base of the transducer, and further improving contact between the device and a subject's skin, thereby further improving coupling between the subject and the device and providing an optimal ultrasound image.

[0066] Though illustrated as two ridges running along the length of the shield base, this particular arrangement is not required for the ridges. For instance, FIG. 5B illustrates another embodiment, including a plurality of ridges **150** running across the width of the bottom surface of a base **236** of a sterilizable shield. Moreover, in those embodiments in which an ultrasound transducer housing is intended for use without a sterile shield, either in a non-sterile field or in those embodiments in which the ultrasound device itself is sterilizable,

ridges can be included on the skin contacting surface of the ultrasound transducer housing itself.

[0067] Ridges formed on the skin contacting surface of a device can cover the entire skin contacting surface, or only a part of the surface, as desired. For instance, the ridges can cover at least a portion of the skin contacting surface through which an ultrasonic beam is transmitted, or can also cover other portions of the skin contacting surface, and in particular, that portion in the vicinity of the probe guide (e.g., on either or both surfaces **108** and **110** of FIG. 1A). Ridges can be of particular benefit on a planar skin contacting surface, such as that illustrated in FIG. 1B, so as to encourage good contact and coupling between a subject's skin, ultrasound coupling gel, and the skin contacting surface of the device.

[0068] Ridges **150** can be formed to any size and shape and of any suitable biocompatible material that can also be, in certain embodiments, a sterilizable material. For example, ridges can have a rounded or straight edge, an individual ridge can lie in a straight line across a skin contacting surface or can curve across the surface, they can vary in height as measured from the base surface to the top edge of the ridge, multiple ridges on a single device can be identical to one another or can vary, ridges can be continuous over a surface or discontinuous, and so forth.

[0069] In one embodiment, ridges **150** can be formed of the same material as other portions of a shield or transducer housing. For instance, the entire section **132**, including ridges **150** can be injection molded from a single polymeric material. In another embodiment, different portions of a sterilizable shield can be formed of different materials. For instance, ridges **150** can be formed of a polymeric material that is softer than is used to form the remainder of sterilizable shield. By way of example, a relatively soft elastomeric polymer (e.g., rubber, styrene-butadiene, soft polyurethanes, etc.) can be utilized. In such cases, ridges can be attached to a device following formation, for instance utilizing a biocompatible adhesive as is known in the art. In one embodiment, ridges can be formed on a specifically shaped component to be attached to the base of the device. For instance, a series of ridges can be formed on an ultrasound wedge as previously discussed, that can be attached either temporarily or permanently to the base of a device.

[0070] As previously stated, the sterilizable shield need not cover the entire ultrasound transducer house. For example, in one embodiment, a sterilizable shield can cover just that portion of an ultrasound transducer housing from which an ultrasonic beam can be emitted. For instance, a shield defining one or more ridges thereon can simply snap onto the base of an ultrasound transducer housing, covering that portion of the housing that will contact a user's skin.

[0071] Another beneficial feature of disclosed devices can be the geometry of a handle of a device. For instance, as previously mentioned with regard to the transducer housing, the angle at which a handle is placed on a probe device can be varied so as to obtain a more comfortable grip on the device while holding the transducer base tightly against the skin. Additional aspects of a can be improved as well. For example, as can be seen on FIG. 5A the handle of shield section **132** can include a finger grip **152** that can improve the grip of a user on the device. In other embodiments additional finger grips can be included, as desired. For instance, in one embodiment finger grips can be provided on a handle such that the handle is specifically designed for left-handed or right-handed use.

[0072] Sterilizable shield 130 also includes section 134, illustrated in FIG. 6. Section 134 can be removably attached to section 132 to enclose an ultrasound transducer housing 100, as previously discussed, Section 134 defines the terminal portion 151 of probe guide 139 in portion 160. Terminal portion 151 is sized so as to snugly reside over the top of guide post 138 of section 132 and form uninterrupted probe guide 139 extending from the top surface of portion 160 of section 134 to the bottom surface of base 136 of section 132.

[0073] It should be understood that a sterilizable shield as disclosed herein is not limited to two completely separable portions. For instance, a sterilizable shield can be hinged and/or can include additional portions, as desired. For instance, a sterilizable shield can be formed of two, three, or more separable sections that can be assembled to enclose all or a portion of an ultrasound housing and form a sterile barrier between the enclosed housing and an exterior field. In another embodiment, a sterilizable shield can be of a unitary construction. For instance, a sterilizable shield can be of a pliant material that can enclose all or a portion of an ultrasound housing and form a sterile barrier between the enclosed housing and an exterior field.

[0074] To assemble a shielded device, ultrasound transducer housing 100 defining probe guide opening 126 can be seated in shield base 136 of section 132 such that guide post 138 extends through transducer housing probe guide opening 126. As probe guide opening 126 of transducer housing 100 is slid over guide post 138, tabs on guide post 138 can slide or snap into recesses of probe guide opening 126 (not shown), helping to properly seat transducer housing 100 in section 132. After ultrasound transducer housing 100 is seated in section 132, section 134 can be aligned with section 132 and fastened into place to cover the top of transducer housing 100. If a protective cap covers the end of guide post 138, it can be removed during assembly and maintain the sterility of the interior of the probe guide 139 throughout the assembly process. Tabs 140 can snap or slide into recesses notch 141 to fasten and secure section 132 and 134 together.

[0075] Following the above described assembly process, probe guide 139 can extend continuously from the top of portion 160 of shield portion 134 through the shield base 136. Moreover, and of great benefit to the device, probe guide 139 can be sterile and within the probe guide opening 126 of ultrasound transducer housing 100.

[0076] Many procedures require a probe to remain at the subcutaneous target for a period of time following insertion of a probe. For example, during the Seldinger technique common for central venous catheter placement, a cannulated needle attached to a syringe is first guided into a vein. After the needle tip is in the lumen of the vein, the needle is held in place while a guide wire is fed down through the needle and into the vein. During this process, only a slight movement of the needle can cause the needle tip to move out of the vein, and the entire procedure must be repeated.

[0077] In order to prevent excessive motion of a probe tip following insertion to a target, one embodiment includes a clamp for the probe. In this embodiment, a device can include a clamp that can firmly hold a probe in the probe device and prevent motion of the probe during subsequent procedures such as catheter insertion, biopsy procedures, fluid aspiration, or the like. Motion of the percutaneous probe tip can be much less likely when the probe is securely clamped to the probe device and the probe device is in turn held and stabilized by

pressing against the subject's skin surface as compared to when only the probe itself is held without clamping to the larger probe device.

[0078] One embodiment of a clamp for use with disclosed probe devices can be seen in FIG. 3. As can be seen, a probe 154 can extend through the probe guide of sterilizable shield 130. Clamp 156 sits atop shield section 134 such that probe 154 passes through clamp aperture 158 as shown.

[0079] Additional details of clamp 156 can be seen with reference to FIGS. 7A and 7B. Aperture 158 includes a wide portion and a narrow portion and defines a clamping surface. The wide portion can be of a size such that a probe can pass freely through the wide portion without hindrance. Aperture 158 can gradually narrow from the wide portion of the aperture to form the narrow portion extending to a tip. Thus, when a probe is located in the wide portion of aperture 158, the clamp can be slid, rotated, or otherwise moved in relation to the probe such that the clamping portion of the clamp crosses the axis of the probe and a clamping surface of the clamp, e.g., a surface of aperture 158 at the narrow portion, can contact the probe and the probe can become tightly trapped in the narrow portion of the aperture 158 as the width of the narrow portion of aperture 158 decreases.

[0080] In another embodiment, rather than trapping a probe between two opposing clamping surfaces, as is the case for the clamp of FIGS. 7A and 7B, a clamping surface can force a probe against the wall of the probe guide to secure the probe in place. For example a clamping surface can be set on a clamp and at an angle with reference to the probe guide. Thus, as the clamp is moved and crosses the probe guide axis, the probe held in the probe guide contacts the clamping surface and becomes pressed against the wall of the probe guide by the force of the single opposing clamping surface and can be firmly gripped between the clamping surface and the wall of the probe guide. In such an embodiment, the clamping surface of the clamp need not be one side of an aperture defined by the clamp, but may be, by way of example, an outer edge of a clamp section, with no opposing piece on the clamp.

[0081] A clamp can be formed of any biocompatible, sterilizable material. For instance, in one embodiment, at least that portion of a clamp that defines a clamping surface can be formed of a material that is harder than a probe to be held by the clamp, for example a hard polymer or a stainless steel. In this embodiment, the clamping surface(s) can cut into the surface of a probe, providing additional holding power in addition to the friction hold provided by trapping the clamp with the clamping surface(s). In another embodiment, however, a clamp, and particularly a clamping surface of a clamp, can be formed of a material that is softer than a probe held in the clamp. For example, a clamp can be formed of a relatively soft polymer such as soft polyurethane or other biocompatible polymeric material. In this embodiment, the clamping surface(s) can deform somewhat as a probe is forced against the clamping surface. The deformation of a clamping surface about a probe can increase the force on the probe, more securely holding the probe in place in the clamp.

[0082] A clamp can define additional features that can improve its holding ability. For instance, a clamping surface can define a series of serrations. Upon contact between a probe and the clamping surface, the serrations of the edges can provide increased surface area for contact between the clamp and the probe, improving hold between the two. Moreover, in those embodiments in which the material forming the clamping surface is harder than that of the probe, serrations

on the surface of the clamping surface can cut into the surface of the probe at the points of contact, further improving hold between the two.

[0083] Referring again to FIGS. 7A and 7B, clamp 156 includes formations 162, 163 that can be used to move clamp 156 and trap probe 154 in the aperture 158 as previously discussed. For example, as illustrated in FIG. 8, a sterilizable shield 130 can be held against the skin surface of a subject and the user can move the clamp 156 with his/her thumb to force the probe into the narrow section of aperture 158 and firmly clamp the probe 154 in place.

[0084] In the illustrated embodiment, clamp 156 includes two formations 162, 163, one on either side of clamp 156 such that the clamp can be operated while held in either the right or left hand of a user. In other embodiments, clamp 156 can include only a single formation, for instance in those embodiments in which a probe device is designed for only right-handed or left-handed use, or alternatively, when the single formation can be accessed from either side of the device. Moreover, the shape of the formations 162, 163 can be any shape that can be accessed by a user and can be pushed, pulled, twisted or otherwise activated to move a clamp and tightly grip a probe in a probe guide. For example a formation can be round, as illustrated, or can be a flat, paddle-shaped formation, a post, or any other convenient shape. Moreover, any formation can be utilized to aid in moving the clamp to force a clamping surface against a probe. For instance, a clamp can define an indentation to be used in moving a clamp. In another embodiment, a clamp can define a rough tactility at a location that can aid in moving the clamp with a thumb or finger. Equivalent or alternative formations would be obvious to one of ordinary skill in the art. For instance, in another embodiment, a portion of the clamp can be rotated so as to force the clamping surface of the clamp against a probe held in the probe guide. By way of example, a probe clamp as is illustrated in U.S. Pat. No. 7,244,234 to Ridley, et al., previously incorporated by reference, can be utilized in conjunction with disclosed devices.

[0085] Referring again to FIG. 3, clamp 156 is attached to shield 130 at a pivot point. For instance, tabs 164 of clamp 156 can fit into recesses 165 formed in the lower section 132 of sterilizable shield 130 (see, e.g., FIG. 5A). During use, clamp 156 can rotate about the pivot point of tabs 164 and over the rounded upper surface of portion 160 of upper section 134 such that the clamping portion, i.e., that portion of clamp 156 that defines the aperture 158 crosses the axis of the probe 154 to lock the probe in place.

[0086] The rotation of a clamp about a pivot to secure a probe is not a requirement of disclosed clamps. For example, in another embodiment, the entire clamp can slide laterally across a portion of a probe device, e.g., a shield or a transducer housing, to clamp a probe in place. In general, any motion of all or a portion of a clamp that can be controlled by a user and can grip a probe as described is encompassed in the present disclosure.

[0087] When a probe is to be removed from a percutaneous location, or if during a procedure, a probe is to be moved from one percutaneous location to another, a projection can be moved in the opposite direction as was used to clamp the probe, freeing the probe.

[0088] FIG. 9 illustrates another embodiment of an ultrasound transducer housing 800 that can be removably attached to a sterilizable shield. According to this embodiment, ultrasound transducer housing 800 can include a handle 802, a

post 804, and a base 806. Ultrasound transducer housing 800 also defines a lower surface 810, as shown. In this particular embodiment, however, the ultrasound transducer housing does not include a probe guide opening. Instead, ultrasound transducer housing 800 is removably attachable to a second portion of a device that defines a probe guide opening. For instance, ultrasound transducer housing 800 can be utilized in conjunction with a sterilizable shield that defines the probe guide. Moreover, the sterilizable shield can be formed of single or multiple removably attachable pieces.

[0089] FIGS. 10A and 10B illustrate one embodiment of a sterilizable shield 930 that can be used in conjunction with an ultrasound device 800 illustrated in FIG. 8. With reference to FIG. 10A, sterilizable shield 930 can be formed of multiple attachable pieces. Specifically, sterilizable shield 930 includes section 932 and section 961 that defines a probe guide for passage of a probe therethrough. Accordingly, section 961 can alternatively be referred to as a probe guide portion. Additionally, section 932 can be separable into two or more sections, as illustrated for device 230 of FIGS. 3-6. Section 961 can also include clamp 956 defining aperture 958 and formations 962, 963 that rotates about pivot 964 for clamping probe 954 in the probe guide. During use, section 961 can be attached to shield 932, for instance by use of aligned tabs and notches, and so forth, so as to attach the probe guide portion to the sterilizable shield, as shown in FIG. 10B.

[0090] Of course, any other arrangements of the individual portions of a device are encompassed within the present disclosure. For instance, in one embodiment, an ultrasound transducer housing that does not define a probe guide opening, as illustrated in FIG. 9, can be removably attached to a probe guide portion that can define a probe guide opening and include the clamp, without enclosing all or a portion of the ultrasound transducer housing in a shield. In another embodiment, a sterilizable shield portion can cover only the skin contacting surface of a device. For instance, a shield portion can snap onto the base of a device. In yet another embodiment, all or a portion of a sterilizable shield can be formed of a pliant material that can enclose an ultrasound transducer housing. According to such an embodiment, a probe guide portion can be indirectly attached to the pliant sterilizable shield portion, for instance by use of a frame or other attachment device that is on the pliant material or optionally on the ultrasound transducer housing itself, such that the pliant material of the shield is held between the frame and the probe guide portion.

[0091] Yet another embodiment is illustrated in FIG. 11. As can be seen according to this embodiment, a device 1000 need not include a separate handle portion. Such a device can be comfortably held by the rounded back portion 1002, while holding the angled skin contacting surface 1110 against a subject. A side view of device 1000 shown in FIG. 12 better illustrates the angle of skin contacting surface 1110. Of course, as discussed above, a device need not include an angle in the skin contacting surface, and in another embodiment the skin contacting surface of a device can be flat with no angle as is shown for the device of FIG. 11, or arcuate.

[0092] A front view of device 1000 is shown in FIG. 13. As can be seen, device 1000 includes attachment slots 1004, 1006 on either side of the device. These attachment slots 1004, 1006 can be utilized to attach another portion to device 1000. For example, FIG. 14 illustrates device 1000 including a probe guide portion 1061 attached to device 1000 via slots

**1004, 1006.** When attached, probe guide portion **1061** can, in one embodiment, be attached such that probe guide **1039** is aligned with an ultrasound transducer located in the base of device **1000**. Of course, device **1000** need not include an ultrasound transducer in the base. FIG. **15** illustrates a side view of device **1000** including probe guide portion **1061** attached thereto. As can be seen, probe guide portion **1061** can define skin contacting surface **1008** and device **1000** can define skin contacting surface **1010**, with the two surfaces **1008, 1010** held at an angle to one another to promote improved contact between a device and a subject, as previously discussed. FIG. **16** is a front view of the embodiment illustrated in FIGS. **14** and **15**.

**[0093]** In one embodiment, all or a portion of device **1000** can be covered or encased with a sterilizable shield. For instance all of the body **1000** of the device can be encased in a sterilizable shield, and the probe guide portion **1061** can then be attached to the sterilizable shield. Alternatively, one a portion of the device, for instance the skin contacting portion, can be covered by a sterilizable shield. In one embodiment, the probe guide portion **1061** can be sterile, and the portion **1000** can be nonsterile.

**[0094]** In one embodiment, a probe guide portion need not include a skin contacting surface. For instance, a separably removable probe guide portion can be attached to a device such that the base of the probe guide portion will be above and not contacting the skin of a subject. According to this embodiment, contact between a subject and a device will only be between the body of a device that encompasses the ultrasound transducer. For instance, when the body of a device incorporates an ultrasound transducer therein, the skin contacting surface can be at the surface from which an ultrasonic beam is emitted, and the probe guide portion can be aligned with the transducer, but held above the skin contacting surface of the body of the device. In this embodiment, a probe passing through a probe guide will exit the probe guide and pass for a distance through the surrounding air prior to contacting the skin of a subject and passing therethrough.

**[0095]** Additionally, though illustrated in FIG. **14** with probe guide portion **1061** completely defining and surrounding the probe guide **1039** that passes therethrough, this is not a requirement of the present disclosure. For example, in another embodiment, a probe guide can be defined between a probe guide portion **1061** and the side of device **1000**. According to this embodiment, a probe guide portion can define a V-shaped notch, a slot, a semi-circular cut out or the like in the side of the probe guide portion that will contact the device **1000**. Upon attachment of the probe guide portion to the body of the device, the probe guide can be completely formed. Moreover, the side of the body of the device can also define a portion of a probe guide, in one embodiment, and the probe guide can be formed between the two removably attachable portions of the device.

**[0096]** A probe guide portion can also be formed of multiple removably attachable pieces, if desired.

**[0097]** FIG. **17** illustrates the device **1000** following attachment of a clamp **1056** to the probe guide portion **1061**. FIG. **17** illustrates this embodiment in a side view and FIG. **18** illustrates this embodiment in a front view. During use, a device can be held against the skin and a probe can be passed through the probe guide. Upon reaching the desired subdermal location, the clamp **1056** can be activated, for instance by the user pulling formation **1063** from the unclamped to the clamped position.

**[0098]** Utilizing presently disclosed devices, a probe tip can be guided to a percutaneous target on a line that is parallel to the plane imaged on a sonogram formed by use of an ultrasound transducer incorporated in a device. For instance, the probe tip can travel on a path that defines a line that is coincident in the scanned plane, is parallel to the scanned plane, or intersects the scanned plane at a point. When utilizing the presently disclosed devices, the path of the probe to the target can be known, even if it cannot be discerned on the sonogram: the probe will advance toward the target on a straight line and at a predetermined angular relationship to the ultrasound housing base from the probe guide opening to the target that is imaged by the ultrasound. Thus, the path of the probe and the scanned plane of the sonogram image can both be defined by the orientation of the transducer and can be coordinated on the target. In order to strike the target, the probe can be merely guided along this known path the desired distance.

**[0099]** In an ideal situation, the probe itself can be visualized on the scanned plane. For instance, in those embodiments in which the path of the probe is on a line within the scanned plane, the probe can be seen in the sonogram, depending on the density of surrounding tissue and other process parameters. However, in one embodiment, even if the path of the probe is coincident with the scanned plane, the probe itself may not be visible on the sonogram, but artifacts of the passage of the probe can be visualized, e.g., shadows, motions of internal structures as the probe passes, and so forth.

**[0100]** In one preferred embodiment, the known path of the probe can be added to the sonogram, and the targeting procedures can be even further simplified. For example, one embodiment includes the addition of a targeting line on the sonogram extending from that point on the sonogram where the probe guide opening exits the housing (or passes the transducer) and projecting across the ultrasonic field in a straight line at the known angle. Thus, if this targeting line is made to intersect the target that is imaged by the device, the operator can be confident that the probe is accurately directed to the target. In other embodiments, other targeting information can be displayed on the sonogram. For example, in one embodiment, information showing the approach of the probe to the target can be displayed.

**[0101]** In one particular embodiment, a motion detector can register motion of a probe in the probe guide, and that information can be displayed, for instance, as a real time image of the probe on a screen or monitor. In this embodiment, the location of the probe tip in relation to the target and the moment when the probe tip strikes the target can be seen in real time by an operator watching the virtual probe on the monitor during the procedure.

**[0102]** FIG. **8** illustrates one embodiment of the presently disclosed subject matter during use in which an image of a virtual probe may be overlaid on a sonogram. In this particular embodiment, the probe device can include a detector **170** located in the post of the sterilizable shield or in the post of the transducer housing. Detector **170** can recognize and monitor the movement of probe **154** as it passes through probe guide and into a subject. Information from detector **170** and the ultrasound transducer can pass through cable **124** to monitor **174**. The probe **154** can then be imaged on a monitor **174** as probe image **178**. The monitor **174** can also show the internal target, for instance a blood vessel **176**.

[0103] A variety of different possible detectors as are generally known in the art may be utilized as detector 170. For instance, detector 170 can utilize infrared (IR), ultrasound, optical, laser, magnetic or other motion detection mechanisms. In addition, the location of detector 170 is not critical to the invention. In the embodiment illustrated in FIG. 8, detector 170 is located in the post of either the shield 130 or the ultrasound transducer housing enclosed within the shield 130. In other embodiments, however, the detector may be located elsewhere in the system including, for example, on a portion of the probe itself.

[0104] Signals from detector 170 can create a data stream which can be sent to a processor. A processing unit can be internal or external to the hand-held device. For example, data from detector 170 can be sent to a standard lap top or desk top computer processor or part of a self-contained ultrasound system as is known in the art. A processor can be loaded with suitable recognition and analysis software and can receive and analyze the stream of data from detector 170. The processing unit can also include standard imaging software as is generally known in the art to receive data from the ultrasound transducer via cable 124. Probe 154 can be of a predetermined length which can be input data entered into a processor by the user or can be preprogrammed into the system as default data. Thus, through analysis of the data stream received from detector 170 and from ultrasound transducer 120, a processor can be programmed to calculate the relative position of the probe tip in relation to the ultrasound transducer 120, in relation to detector 170, in relation to the exit of the probe guide, or to any other convenient reference point. A processor can communicate this position information digitally to monitor 174 and the information can be displayed on the monitor such as in a numerical format or optionally as a real time image of a virtual probe 178 shown in conjunction with the sonogram including an image 176 of the target, such as a blood vessel.

[0105] In such a manner, disclosed devices can be utilized to actually show the approach of the probe toward the target on the monitor throughout the entire procedure. In addition, in certain embodiments, disclosed devices can be utilized to ensure the probe tip remains at the target during subsequent procedures. For example, in those embodiments wherein the detector 170 monitors the motion of the probe 154, as long as probe 154 remains 'visible' to detector 170, the image 176 of probe 154 can remain on the monitor 174. Thus, any motion of the probe tip in relation to the target can be noted by an observer.

[0106] The presently disclosed ultrasound guided probe devices and methods may be utilized in many different medical procedures. Exemplary applications for the devices can include, without limitation

- [0107] Central Venous Catheterization
- [0108] Cardiac Catheterization (Central Arterial Access)
- [0109] Dialysis Catheter Placement
- [0110] Breast Biopsies
- [0111] Paracentesis
- [0112] Pericardiocentesis
- [0113] Thoracentesis
- [0114] Arthrocentesis
- [0115] Lumbar Puncture
- [0116] Epidural Catheter Placement
- [0117] Peripherally Inserted Central Catheter (PICC) line placement
- [0118] Thyroid Nodule Biopsies

[0119] Cholecystic Drain Placement

[0120] Amniocentesis

[0121] Regional Anesthesia—Nerve Block

[0122] Some of these exemplary procedures have employed the use of ultrasound in the past, and all of these procedures, as well as others not specifically listed, could utilize the disclosed ultrasound guided devices to improve procedural safety as well as patient safety and comfort, in addition to provide more economical use of ultrasound devices. In addition, the presently disclosed devices may be utilized with standard probe kits already available on the market.

[0123] It will be appreciated that the foregoing examples, given for purposes of illustration, are not to be construed as limiting the scope of this invention. Although only a few exemplary embodiments of this invention have been described in detail above, those skilled in the art will readily appreciate that many modifications are possible in the exemplary embodiments without materially departing from the novel teachings and advantages of this invention. Accordingly, all such modifications are intended to be included within the scope of this invention which is defined in the following claims and all equivalents thereto. Further, it is recognized that many embodiments may be conceived that do not achieve all of the advantages of some embodiments, yet the absence of a particular advantage shall not be construed to necessarily mean that such an embodiment is outside the scope of the present invention.

What is claimed is:

1. A single-use sterilizable shield comprising a first section, a second section and a fastener for connecting the first section and the second section to one another, wherein the fastener is a single-use fastener that is permanently disabled upon disconnection and separation of the first section and the second section from one another, the single-use sterilizable shield comprising a probe guide, the single-use sterilizable shield comprising a skin contacting surface that defines an opening therethrough, the opening being a terminus of the probe guide.

2. The single-use sterilizable shield of claim 1, wherein the probe guide is adapted for receipt in a probe guide opening defined by an ultrasound transducer housing.

3. The single-use sterilizable shield of claim 1, wherein the skin contacting surface comprises a first portion defining a first plane and a second portion defining a second plane, the first portion and the second portion being contiguous, the first plane and the second plane intersecting one another to define an angle therebetween that is greater than about 150° and less than 180°, the angle being determined between the first and second portions of the skin contacting surface and external to the shield.

4. The single-use sterilizable shield of claim 3, the first portion defining the opening therethrough.

5. The single-use sterilizable shield of claim 4, the second portion being adapted to conform to the base of an ultrasound transducer housing such that an ultrasonic beam transmitted from an ultrasound transducer held within the ultrasound transducer housing issues from the second portion.

6. The single-use sterilizable shield of claim 1, the second section comprising the skin contacting surface.

7. The single-use sterilizable shield of claim 6, the first section comprising a first portion of the probe guide and the second section comprising a second section of the probe guide.

8. The single-use sterilizable shield of claim 1, the sterilizable shield further comprising a third section, the third section comprising the probe guide, the third section being removably attachable to the first section or the second section.

9. The single-use sterilizable shield of claim 1, the sterilizable shield further comprising at least one raised ridge on said skin contacting surface.

10. The single-use sterilizable shield of claim 25, the sterilizable shield further comprising a clamp for clamping a probe in the probe guide.

11. A method for guiding a probe to a percutaneous target comprising:

seating an ultrasound transducer housing within a first section of a sterilizable shield, the ultrasound transducer housing including an ultrasound transducer for transmitting an ultrasonic beam and receiving reflections of the ultrasonic beam;

aligning a second section of the sterilizable shield with the first section of the sterilizable shield, wherein the second section of the sterilizable shield encloses a portion of the ultrasound transducer housing;

fastening the first and second sections of the sterilizable shield to one another by use of a single-use fastener to enclose at least that portion of the ultrasound transducer housing that includes the ultrasound transducer within the sterilizable shield;

guiding a probe defining a probe tip such that the probe tip arrives at the percutaneous target; and

disassembling the first section and the second section from one another, wherein the single-use fastener is permanently disabled upon the disassembly.

12. The method according to claim 11, wherein the sterilizable shield comprises a probe guide.

13. The method according to claim 12, wherein the ultrasound transducer housing defines a probe guide opening, the probe guide being received into the probe guide opening upon seating the ultrasound transducer housing within the first section of the sterilizable shield.

14. The method according to claim 12, the first section of the sterilizable shield comprising a first section of the probe guide and the second section of the sterilizable shield comprising a second section of the probe guide, the first and second sections of the probe guide being attached to one another upon fastening of the first and second sections of the sterilizable shield to one another.

15. The method according to claim 11, the method further comprising attaching a probe guide portion to the sterilizable shield, the probe guide portion comprising a probe guide.

16. The method according to claim 11, further comprising clamping the probe in the probe guide when the probe tip is at the percutaneous target.

17. The method according to claim 11, further comprising transmitting an ultrasonic beam from the transducer assembly, and forming a sonogram of the percutaneous target in response to the reflections of the ultrasonic beam.

18. The method according to claim 17, further comprising forming a virtual image of the probe on the sonogram.

\* \* \* \*

专利名称(译)	用于探针引导的超声装置和用于其的可消毒护罩		
公开(公告)号	<a href="#">US20150209008A1</a>	公开(公告)日	2015-07-30
申请号	US14/680424	申请日	2015-04-07
[标]申请(专利权)人(译)	SOMA DEV		
申请(专利权)人(译)	SOMA发展有限责任公司		
当前申请(专利权)人(译)	SOMA研究有限责任公司		
[标]发明人	RIDLEY STEPHEN F HAGY M DEXTER		
发明人	RIDLEY, STEPHEN F. HAGY, M. DEXTER		
IPC分类号	A61B8/00		
CPC分类号	A61B8/4209 A61B8/4422 A61B1/00142 A61B8/0833 A61B8/0841 A61B8/4254 A61B8/4281 A61B8/461 A61B17/3403 A61B46/10 A61B2017/00296 A61B2017/00858 A61B2017/3405 A61B2017/3413		
其他公开文献	US9351704		
外部链接	<a href="#">Espacenet</a> <a href="#">USPTO</a>		

摘要(译)

公开了医疗探针装置和在医疗过程中使用经皮探针引导的方法。探针装置包括超声换能器壳体，其具有穿过其中的通道，该通道构造成容纳探针。该装置可用于将探针通过探针导向器引导至经皮靶，并在手术期间实时可视化探针。另外，所述装置可包括可消毒的护罩，所述护罩包括无菌探针引导件，使得换能器壳体本身可通过无菌屏障与受试者分离。可消毒护罩可以是一次性护罩，可以防止污染和重复使用护罩。所述装置可以限定有益于几个操作者使用的有益几何形状，其可以用于皮肤表面附近的经皮目标并且可以使装置与受试者的皮肤表面之间实现极好的接触。

