



US 20100228128A1

(19) **United States**

(12) **Patent Application Publication**
Lee

(10) **Pub. No.: US 2010/0228128 A1**
(43) **Pub. Date: Sep. 9, 2010**

(54) **TRANSMIT/RECEIVE ISOLATION FOR AN ULTRASOUND SYSTEM**

(52) **U.S. Cl. 600/443**

(76) **Inventor: Hong Gyo Lee, Seoul (KR)**

(57) **ABSTRACT**

Correspondence Address:
JONES DAY
222 EAST 41ST ST
NEW YORK, NY 10017 (US)

A transmit/receive isolation for an ultrasound system to block a high voltage transmit signal from being propagated to a receiving unit during a transmission period of an ultrasound signal is disclosed. An ultrasound system comprises: a transmitting unit configured to form a plurality of transmit signals; an ultrasound probe configured to convert the transmit signals to a plurality of ultrasound signals, transmit the ultrasound signals to a target object, receive a plurality of echo signals reflected from the target object and form a plurality of receive signals based on the echo signals; a receiving unit; and a switching unit coupled to the transmitting unit, the ultrasound probe and the receiving unit and comprising a plurality of diode bridges each being switchable between first and second states such that the respective transmit signal is blocked from being propagated to the receiving unit when the diode bridge is in the first state and the respective receive signal is allowed to be propagated to the receiving unit when the diode bridge is in the second state.

(21) **Appl. No.: 12/698,889**

(22) **Filed: Feb. 2, 2010**

(30) **Foreign Application Priority Data**

Mar. 5, 2009 (KR) 10-2009-0018940

Publication Classification

(51) **Int. Cl. A61B 8/14 (2006.01)**

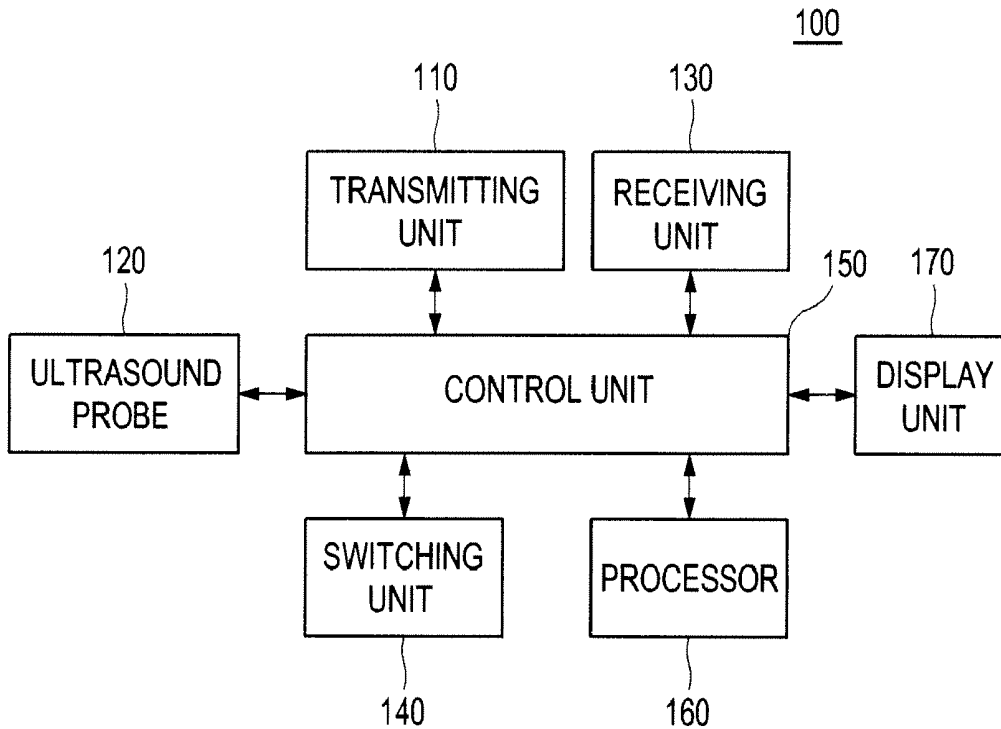

FIG. 1

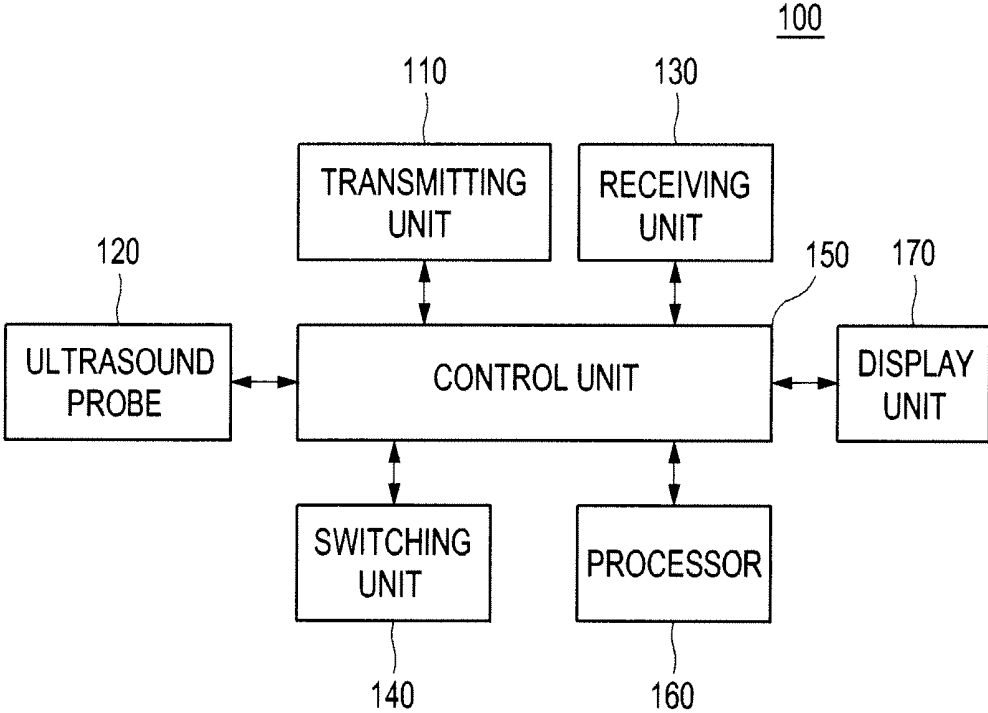
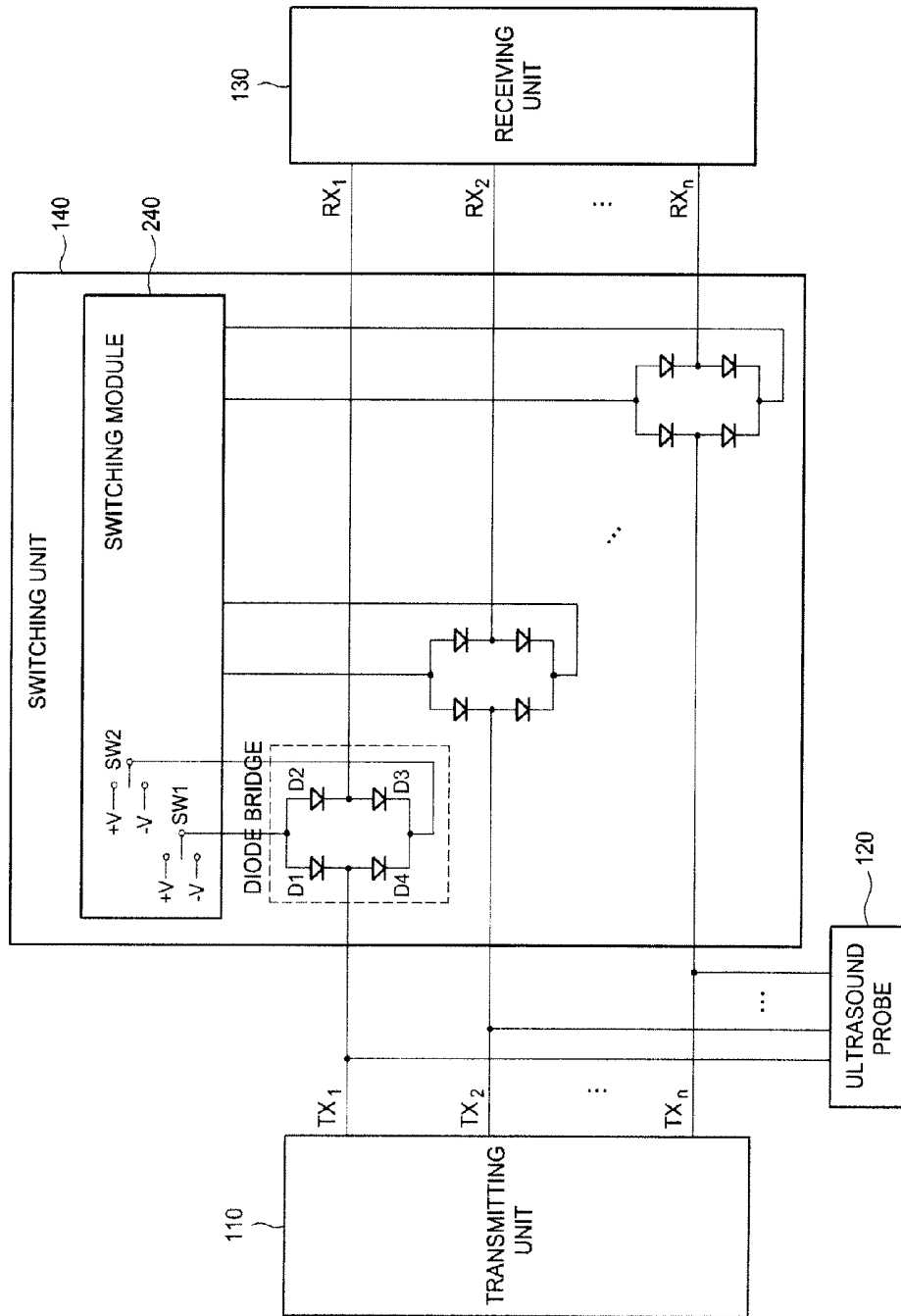

FIG. 2



TRANSMIT/RECEIVE ISOLATION FOR AN ULTRASOUND SYSTEM

CROSS-REFERENCE TO RELATED APPLICATIONS

[0001] The present application claims priority from Korean Patent Application No. 10-2009-18940 filed on Mar. 5, 2009, the entire subject matter of which is incorporated herein by reference.

TECHNICAL FIELD

[0002] The present disclosure relates to ultrasound systems, and more particularly to transmit/receive isolation for an ultrasound system, with which a high voltage transmit signal is blocked from being propagated to a receiving unit during a transmission period.

BACKGROUND

[0003] Due to its non-invasive and non-destructive nature, an ultrasound system has been extensively used for acquiring internal information of a target object in the medical profession. Since the ultrasound system may provide a high resolution image to a doctor without a surgical treatment, which is performed by directly incising and observing the target object, it is very helpful in the medical profession.

[0004] Generally, an ultrasound system includes a transmit/receive switch. The transmit/receive switch connects a transmitting unit with an ultrasound probe during a transmission period of an ultrasound signal to transmit a high voltage transmit signal from a receiving unit to an ultrasound probe. At the same time, the transmit/receive switch blocks a transmit signal to be propagated to the receiving unit. The transmit/receive switch connects the receiving unit with the ultrasound probe during a receiving period of an ultrasound signal to transmit the receive signal outputted from the ultrasound probe, which receives the ultrasound signal reflected from a target object (i.e., ultrasound echo signal), to the receiving unit.

[0005] When an ultrasound image in thin depth is obtained with the conventional ultrasound system, a high voltage transmit signal is propagated to the receiving unit. This is because the transmit/receive switch cannot completely block the transmit signal to be propagated to the receiving unit. This not only affects the receiving unit but also reduces quality of the ultrasound image.

SUMMARY

[0006] Embodiments of an ultrasound system for blocking a high voltage transmit signal to be propagated to a receiving unit during a transmission period of an ultrasound signal are disclosed herein.

[0007] In one embodiment, by way of non-limiting example, an ultrasound system comprises: a transmitting unit configured to form a plurality of transmit signals; an ultrasound probe configured to convert the transmit signals to a plurality of ultrasound signals, transmit the ultrasound signals to a target object, receive a plurality of echo signals reflected from the target object and form a plurality of receive signals based on the echo signals; a receiving unit; and a switching unit coupled to the transmitting unit, the ultrasound probe and the receiving unit and comprising a plurality of diode bridges each being switchable between first and second states such that the respective transmit signal is blocked from

being propagated to the receiving unit when the diode bridge is in the first state and the respective receive signal is allowed to be propagated to the receiving unit when the diode bridge is in the second state.

[0008] In one embodiment, by way of non-limiting example, an ultrasound system comprises: a transmitting unit configured to form a plurality of transmit signals; an ultrasound probe configured to convert the transmit signals to a plurality of ultrasound signals, transmit the ultrasound signals to a target object, receive a plurality of echo signals reflected from the target object and form a plurality of receive signals based on the echo signals; a receiving unit; a switching unit coupled to the transmitting unit, the ultrasound probe and the receiving unit; a voltage measuring unit configured to measure a voltage of each of the transmit signals to form a measured voltage; and a control unit configured to perform the following steps: comparing the measured voltage with a predetermined threshold voltage, controlling the switching unit to block the transmit signal from being propagated to the receiving unit if the measured voltage is over the predetermined threshold voltage and controlling the switching unit to allow the receive signal to be propagated to the receiving unit if the measured voltage is below the predetermined threshold voltage.

[0009] In one embodiment, by way of non-limiting example, an ultrasound system comprises: a transmitting unit configured to form a plurality of transmit signals; an ultrasound probe configured to convert the transmit signals to a plurality of ultrasound signals, transmit the ultrasound signals to a target object, receive a plurality of echo signals reflected from the target object and form a plurality of receive signals based on the echo signals; a receiving unit; a switching unit coupled to the transmitting unit, the ultrasound probe and the receiving unit; a voltage measuring unit configured to measure a voltage of each of the transmit signals to form a measured voltage; and a control unit responsive to a blocking instruction to control the switching unit to block the corresponding transmit signal from being propagated to the receiving unit and further responsive to a non-blocking instruction to control the switching unit to allow the corresponding receive signal to be propagated to the receiving unit.

[0010] In one embodiment, by way of non-limiting example, an ultrasound system comprises: a transmitting unit configured to form a transmit signal; an ultrasound probe configured to convert the transmit signal to an ultrasound signal, the ultrasound probe being further configured to transmit the ultrasound signal to a target object during a transmit period, receive an echo signal reflected from the target object during a receive period and form a receive signal based on the echo signal; a receiving unit; and a switching unit coupled to the transmitting unit, the ultrasound probe and the receiving unit and comprising a plurality of diode bridges, each being configured to block the respective transmit signal from being propagated to the receiving unit during the transmit period and allow the respective receive signal to be propagated to the receiving unit during the receive period.

[0011] The Summary is provided to introduce a selection of concepts in a simplified form that are further described below in the Detailed Description. This Summary is not intended to identify key or essential features of the claimed subject matter, nor is it intended to be used in determining the scope of the claimed subject matter.

BRIEF DESCRIPTION OF THE DRAWINGS

[0012] FIG. 1 is a block diagram showing an illustrative embodiment of an ultrasound system applied to a switching unit according to the present invention.

[0013] FIG. 2 is an illustrative a switching unit according to an embodiment of the present invention.

DETAILED DESCRIPTION

[0014] The present invention is described below in view of the provided drawings.

[0015] FIG. 1 is a block diagram showing an illustrative embodiment of an ultrasound system 100 applied to a switching unit 140 according to the present invention. A transmitting unit 110 forms a high voltage transmit signal to obtain frames. The frames include B mode (brightness mode) image, D mode (Doppler mode) image, c mode (color mode) image, elasticity image, etc.

[0016] An ultrasound probe 120 converts transmit signals to a plurality of ultrasound signals, transmits them to a target object, receives a plurality of echo signals reflected from the target object and forms a plurality of receive signals based on the ultrasound echo signals. The ultrasound probe 120 includes a plurality of transducer elements for converting an ultrasound signal into an electronic signal and vice-versa.

[0017] A receiving unit 130 converts a plurality of receive signals from the ultrasound probe 120 to analog signals. In addition, the receiving unit 130 focuses a plurality of receive signals, which are converted in digital, based on a focusing point and position of a transducer element on the ultrasound probe 120. The receiving unit 130 forms a plurality of ultrasound data by using the plurality of receive and focusing signals.

[0018] A switching unit 140 is coupled to the transmitting unit 110, the ultrasound probe 120 and the receiving unit 130. The switching unit 140 connects the transmitting unit 110 to the ultrasound probe 120 during a transmission period of an ultrasound signal and transmits a high voltage transmit signal from the transmitting unit 110 to the ultrasound probe 120. At the same time, the switching unit 140 blocks the transmit signal to be propagated to the receiving unit 130. Also, the switch unit 140 connects the receiving unit 130 with the ultrasound probe 120 during a receiving period of an ultrasound signal and transmits the receive signal from the ultrasound probe 120 to the receiving unit 130.

[0019] Now referring to FIG. 2, the switching unit 140 is described for isolating the receiving unit 130 from transmit signal during the transmission period of the ultrasound signal. In one embodiment, the switching unit 140 comprises a plurality of diode bridges, each being switchable between first and second states such that the respective transmit signal is blocked from being propagated to the receiving unit 130 when the diode bridge is in the first state and the respective receive signal is allowed to be propagated to the receiving unit 130 when the diode bridge is in the second state. The switching unit 140 further comprises a switching module 240 connected to the diode bridges. The switching module 240 is operable to reverse-bias the diode bridge in the first state and forward-bias the diode bridge in the second state. In one embodiment, the switching module 240 comprises a pair of switches. During the transmission period of an ultrasound signal, a first switch SW 1 is connected to a minus voltage terminal $-V$ and a second switch SW 2 is connected to a plus voltage terminal $+V$, to make the diode bridge off. Thus, a high voltage signal from the transmitting unit 110 may not be propagated to the receiving unit 130 and the receiving unit 130 can be completely isolated. On the other hand, during the receiving period of an ultrasound signal, the first switch SW 1 is connected to the plus voltage terminal $+V$ and the second

switch SW 2 is connected to a minus voltage terminal $-V$. Thus, the diode bridge is on and forward bias current may be propagated to the diode bridge. As such, the receive signal from the ultrasound probe 120 is transmitted to the receiving unit 130 via the diode bridge. The first and second switches can be implemented with mechanical relay transistors, field effect transistors (FET), etc. The switching module 240 is configured to control the diode bridges to be individually or simultaneously switchable.

[0020] Now referring FIG. 1, the control unit 150 controls the switching unit 140. Also, the control unit 150 controls transmit/receive of an ultrasound signal, as well as the formation and display of ultrasound images. The control unit 150 is responsive to a blocking instruction to control the switching unit to block the corresponding transmit signal from being propagated to the receiving unit, the control unit is further responsive to a non-blocking instruction to control the switching unit to allow the corresponding receive signal to be propagated to the receiving unit.

[0021] A processor 160 forms ultrasound images by using a plurality of ultrasound data from the receiving unit 130. A display unit 170 displays ultrasound images formed in the processor 160.

[0022] In one embodiment, an ultrasound system may include a voltage measuring unit. The voltage measuring unit may measure voltage of each of transmit signals during a transmission period of ultrasound signals and form a measured voltage. The control unit 150 may be operable to perform the following steps: comparing the measured voltage with a predetermined threshold voltage, controlling the switching unit 140 to block the respective transmit signal from being propagated to the receiving unit 130 if the measured voltage is over the predetermined threshold voltage, controlling the switching unit 140 to allow the respective receive signal to be propagated to the receiving unit 130 if the measured voltage is below the threshold voltage.

[0023] Although embodiments have been described with reference to a number of illustrative embodiments thereof, it should be understood that numerous other modifications and embodiments can be devised by those skilled in the art that will fall within the spirit and scope of the principles of this disclosure. More particularly, numerous variations and modifications are possible in the component parts and/or arrangements within the scope of the disclosure, the drawings and the appended claims. In addition to variations and modifications in the component parts and/or arrangements, alternative uses will also be apparent to those skilled in the art.

[0024] The terminology used herein is for the purpose of describing particular embodiments only and is not intended to be limiting of the invention. As used herein, the singular forms "a," "an" and "the" are intended to include the plural forms as well, unless the context clearly indicates otherwise. It will be further understood that the terms "comprises" and/or "comprising," when used in this specification, specify the presence of stated features, integers, steps, operations, elements, and/or components, but do not preclude the presence or addition of one or more other features, integers, steps, operations, elements, components, and/or groups thereof.

What is claimed is:

1. An ultrasound system, comprising:
 - a transmitting unit configured to form a plurality of transmit signals;
 - an ultrasound probe configured to convert the transmit signals to a plurality of ultrasound signals, transmit the

ultrasound signals to a target object, receive a plurality of echo signals reflected from the target object and form a plurality of receive signals based on the echo signals; a receiving unit; and

a switching unit coupled to the transmitting unit, the ultrasound probe and the receiving unit and comprising a plurality of diode bridges each being switchable between first and second states such that the respective transmit signal is blocked from being propagated to the receiving unit when the diode bridge is in the first state and the respective receive signal is allowed to be propagated to the receiving unit when the diode bridge is in the second state.

2. The ultrasound system of claim 1, wherein the switching unit further comprises a switching module connected to the diode bridges.

3. The ultrasound system of claim 2, wherein the switching module is configured to forward-bias the diode bridge in the second state.

4. The ultrasound system of claim 2, wherein the switching module is configured to reverse-bias the diode bridge in the first state.

5. The ultrasound system of claim 2, wherein the switching module comprises a pair of switches.

6. The ultrasound system of claim 2, wherein the switching module is configured to control the diode bridges to be individually or simultaneously switchable.

7. An ultrasound system, comprising:

a transmitting unit configured to form a plurality of transmit signals;

an ultrasound probe configured to convert the transmit signals to a plurality of ultrasound signals, transmit the ultrasound signals to a target object, receive a plurality of echo signals reflected from the target object and form a plurality of receive signals based on the echo signals;

a receiving unit;

a switching unit coupled to the transmitting unit, the ultrasound probe and the receiving unit;

a voltage measuring unit configured to measure a voltage of each of the transmit signals to form a measured voltage; and

a control unit configured to perform the following steps:

comparing the measured voltage with a predetermined threshold voltage,

controlling the switching unit to block the transmit signal from being propagated to the receiving unit if the measured voltage is over the predetermined threshold voltage, and

controlling the switching unit to allow the receive signal to be propagated to the receiving unit if the measured voltage is below the predetermined threshold voltage.

8. The ultrasound system of claim 7, wherein the switching unit comprises a plurality of diode bridges coupled to the transmitting unit and the receiving unit and the control unit is configured to control the diode bridges.

9. The ultrasound system of claim 8, wherein the switching unit further comprises a switching module connected to the diode bridges.

10. An ultrasound system, comprising:

a transmitting unit configured to form a plurality of transmit signals;

an ultrasound probe configured to convert the transmit signals to a plurality of ultrasound signals, transmit the ultrasound signals to a target object, receive a plurality of echo signals reflected from the target object and form a plurality of receive signals based on the echo signals;

a receiving unit;

a switching unit coupled to the transmitting unit, the ultrasound probe and the receiving unit;

a voltage measuring unit configured to measure a voltage of each of the transmit signals to form a measured voltage; and

a control unit responsive to a blocking instruction to control the switching unit to block the corresponding transmit signal from being propagated to the receiving unit, the control unit being further responsive to a non-blocking instruction to control the switching unit to allow the corresponding receive signal to be propagated to the receiving unit.

11. An ultrasound system, comprising:

a transmitting unit configured to form a transmit signal;

an ultrasound probe configured to convert the transmit signal to an ultrasound signal, the ultrasound probe being further configured to transmit the ultrasound signal to a target object during a transmit period, receive an echo signal reflected from the target object during a receive period and form a receive signal based on the echo signal;

a receiving unit; and

a switching unit coupled to the transmitting unit, the ultrasound probe and the receiving unit and comprising a plurality of diode bridges, each being configured to block the respective transmit signal from being propagated to the receiving unit during the transmit period and allow the respective receive signal to be propagated to the receiving unit during the receive period.

* * * * *

专利名称(译)	超声系统的发送/接收隔离		
公开(公告)号	US20100228128A1	公开(公告)日	2010-09-09
申请号	US12/698889	申请日	2010-02-02
[标]申请(专利权)人(译)	李弘GYO		
申请(专利权)人(译)	李, 洪GYO		
当前申请(专利权)人(译)	三星MEDISON CO., LTD.		
[标]发明人	LEE HONG GYO		
发明人	LEE, HONG GYO		
IPC分类号	A61B8/14		
CPC分类号	A61B8/00 A61B8/54 A61B8/4444 A61B8/4483 A61B8/461 A61B8/485 A61B8/488 A61B8/5207 G01S7/52017 G01S7/5205		
优先权	1020090018940 2009-03-05 KR		
其他公开文献	US9380993		
外部链接	Espacenet USPTO		

摘要(译)

公开了一种用于超声系统的发射/接收隔离，以阻止高压发射信号在超声信号的发射周期期间传播到接收单元。一种超声系统，包括：发送单元，被配置为形成多个发送信号；超声探头，被配置为将发射信号转换为多个超声信号，将超声信号发射到目标对象，接收从目标对象反射的多个回波信号，并基于回波信号形成多个接收信号；接收单元；开关单元，耦合到发送单元，超声探头和接收单元，并且包括多个二极管桥，每个二极管桥可在第一和第二状态之间切换，使得当二极管阻止相应的发送信号传播到接收单元。当二极管桥处于第二状态时，桥接器处于第一状态，并且允许相应的接收信号传播到接收单元。

