



(19) **United States**

(12) **Patent Application Publication**
Kim et al.

(10) **Pub. No.: US 2010/0274132 A1**
(43) **Pub. Date: Oct. 28, 2010**

(54) **ARRANGING A THREE-DIMENSIONAL
ULTRASOUND IMAGE IN AN ULTRASOUND
SYSTEM**

Publication Classification

(51) **Int. Cl.**
A61B 8/14 (2006.01)
G06K 9/00 (2006.01)
(52) **U.S. Cl.** **600/443; 382/131**
(57) **ABSTRACT**

(76) **Inventors:** **Chul An Kim**, Seoul (KR); **Sung
Yoon Kim**, Seoul (KR); **Sung Mo
Lee**, Seoul (KR)

Correspondence Address:
JONES DAY
222 EAST 41ST ST
NEW YORK, NY 10017 (US)

Embodiments for arranging a 3D (three-dimensional) ultrasound image are disclosed. In one embodiment, by way of non-limiting example, an ultrasound system comprises: a storage unit for storing a plurality of reference position information each corresponding to a plurality of target objects; a user input unit configured to receive input information for selecting a target object; an ultrasound data acquisition unit configured to transmit and receive ultrasound signals to and from the target object to thereby output ultrasound data; and a processing unit in communication with the storage unit, the user input unit and the ultrasound data acquisition unit, the processing unit being configured to form a 3D ultrasound image based on the ultrasound data and perform position arrangement of the 3D ultrasound image based on reference position information corresponding to the input information.

(21) **Appl. No.:** **12/729,047**

(22) **Filed:** **Mar. 22, 2010**

(30) **Foreign Application Priority Data**

Apr. 27, 2009 (KR) 10-2009-0036300

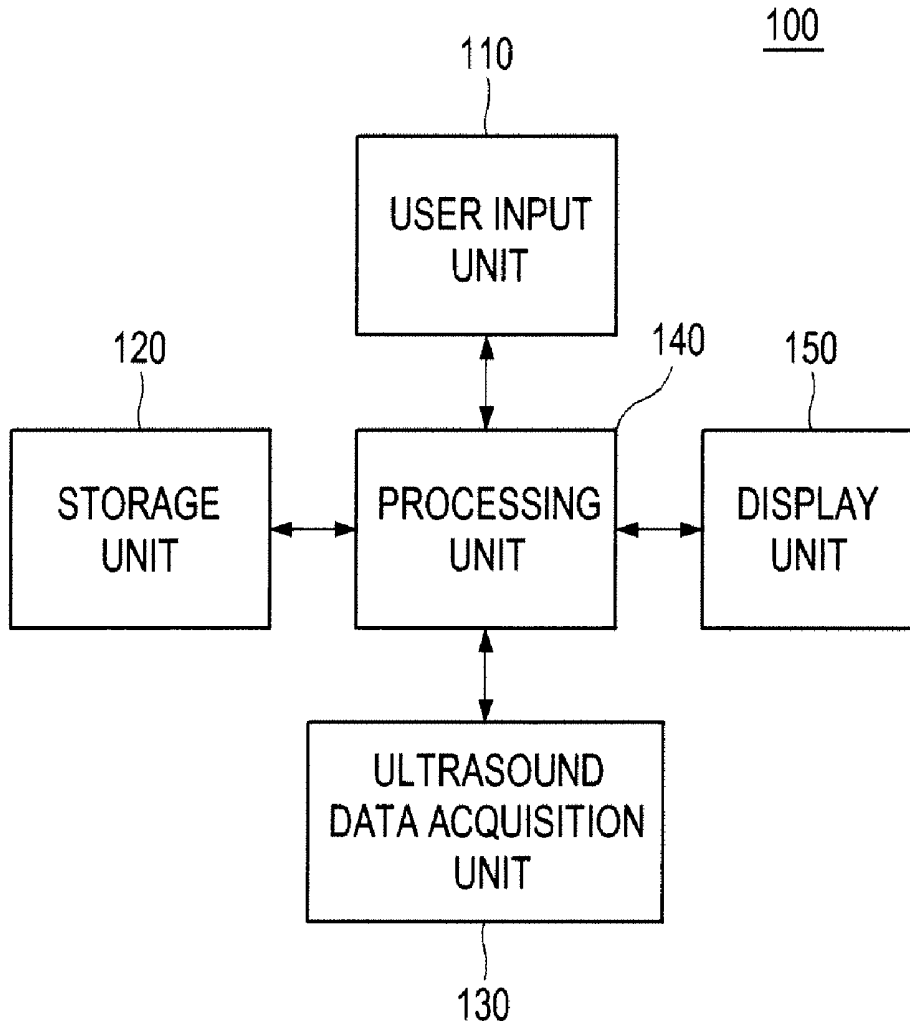

FIG. 1

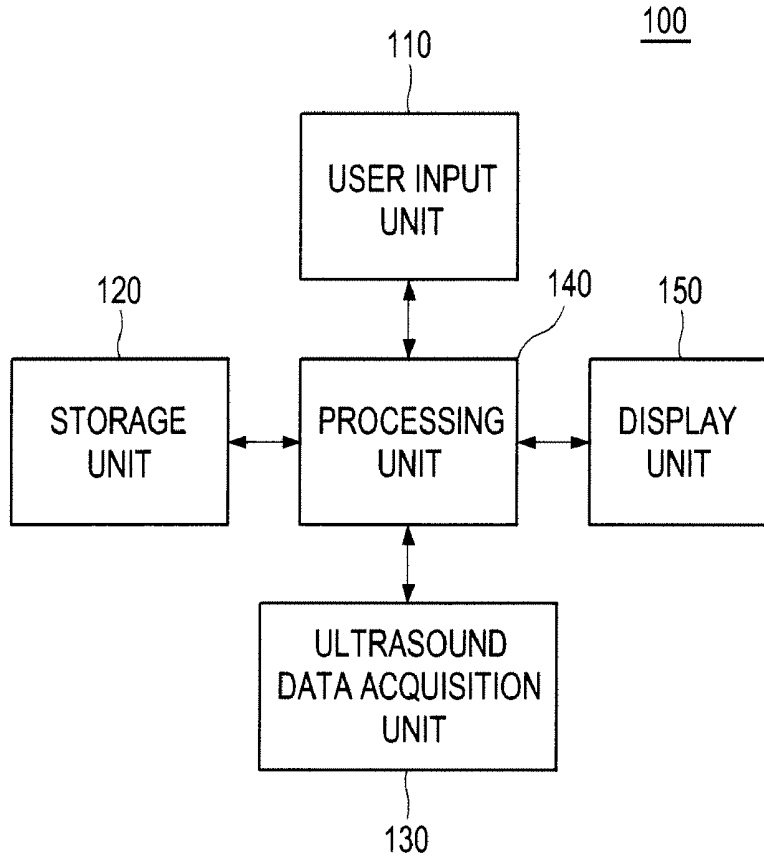

FIG. 2

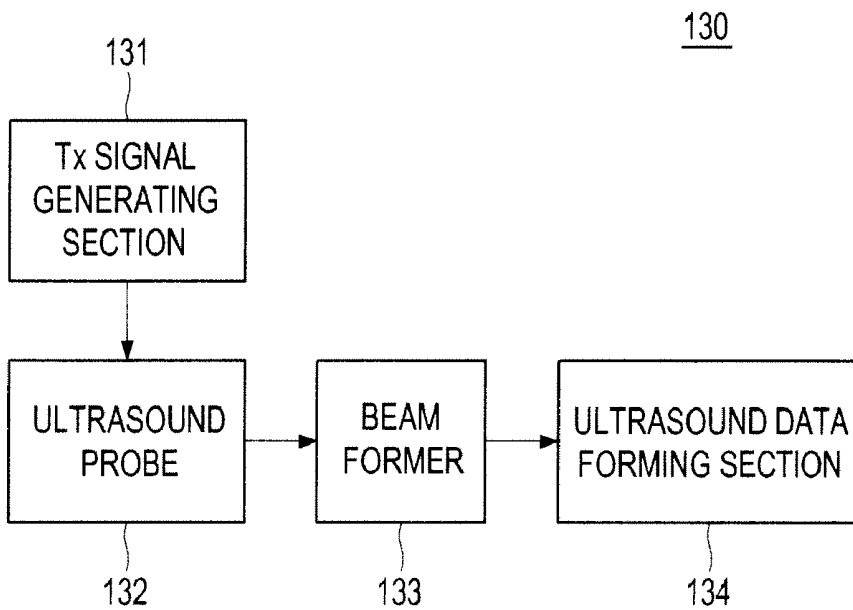

FIG. 3

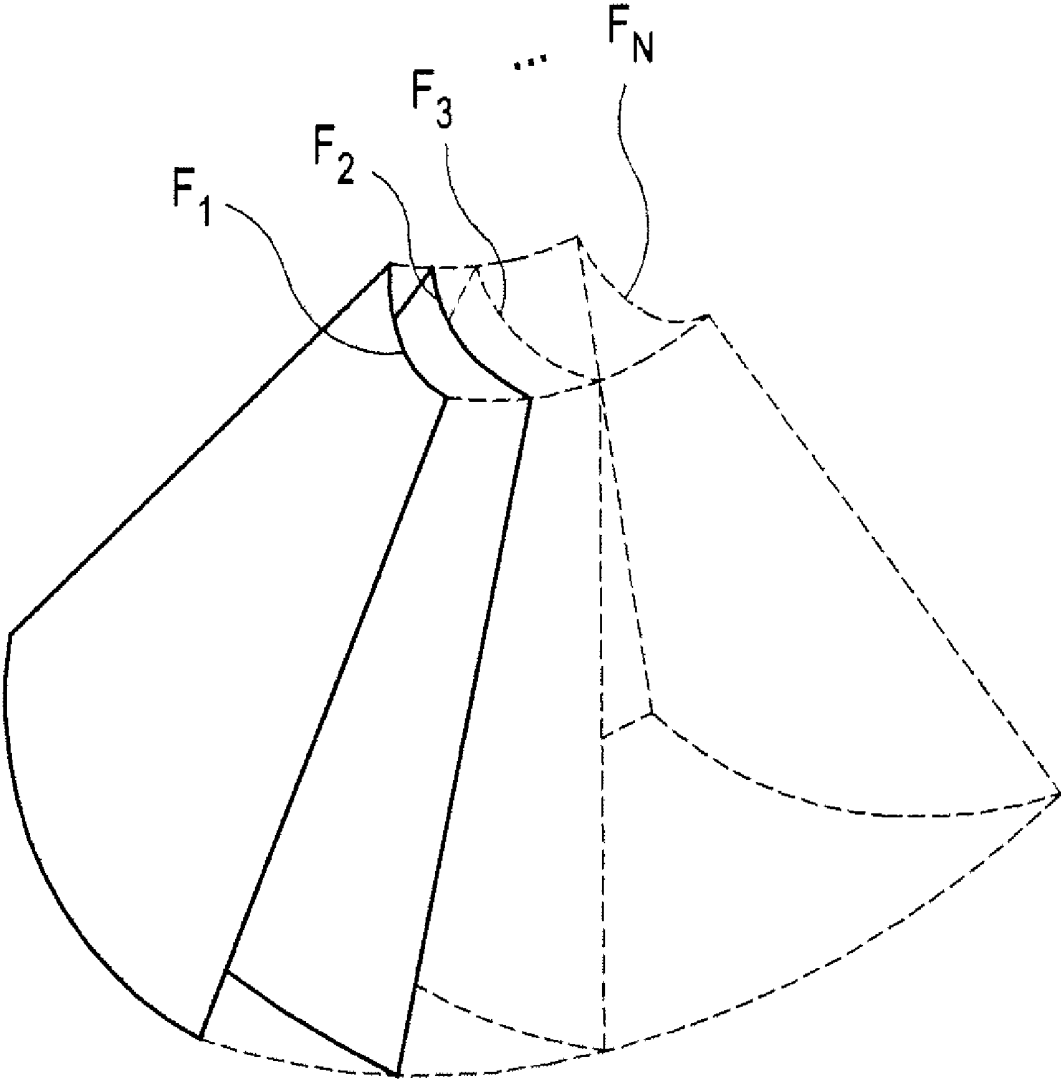

FIG. 4

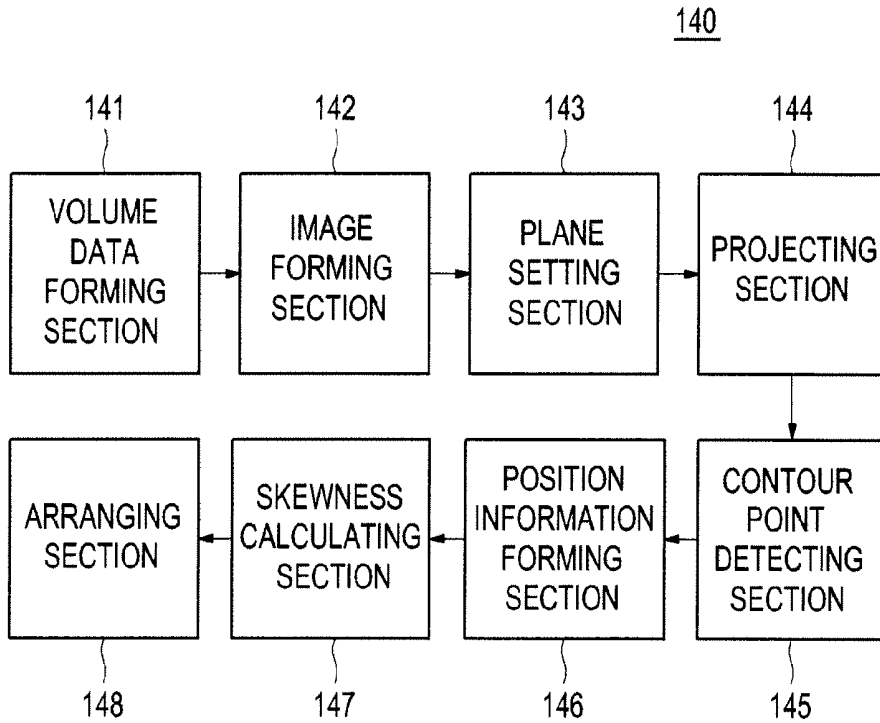

FIG. 5

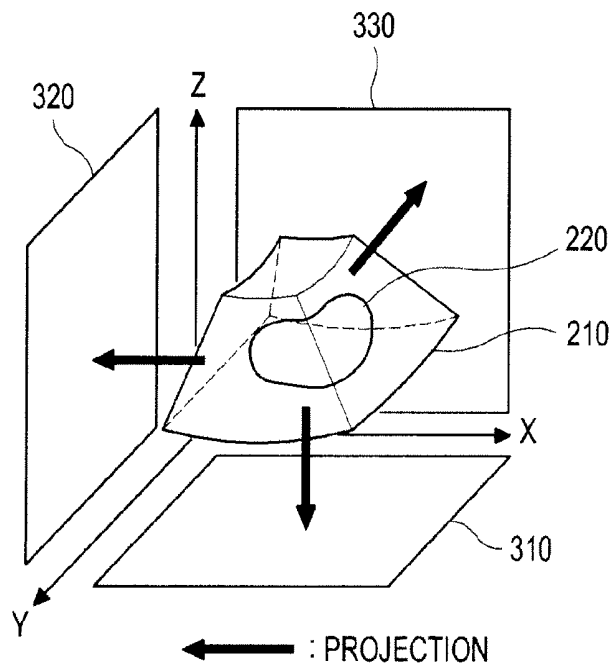

FIG. 6

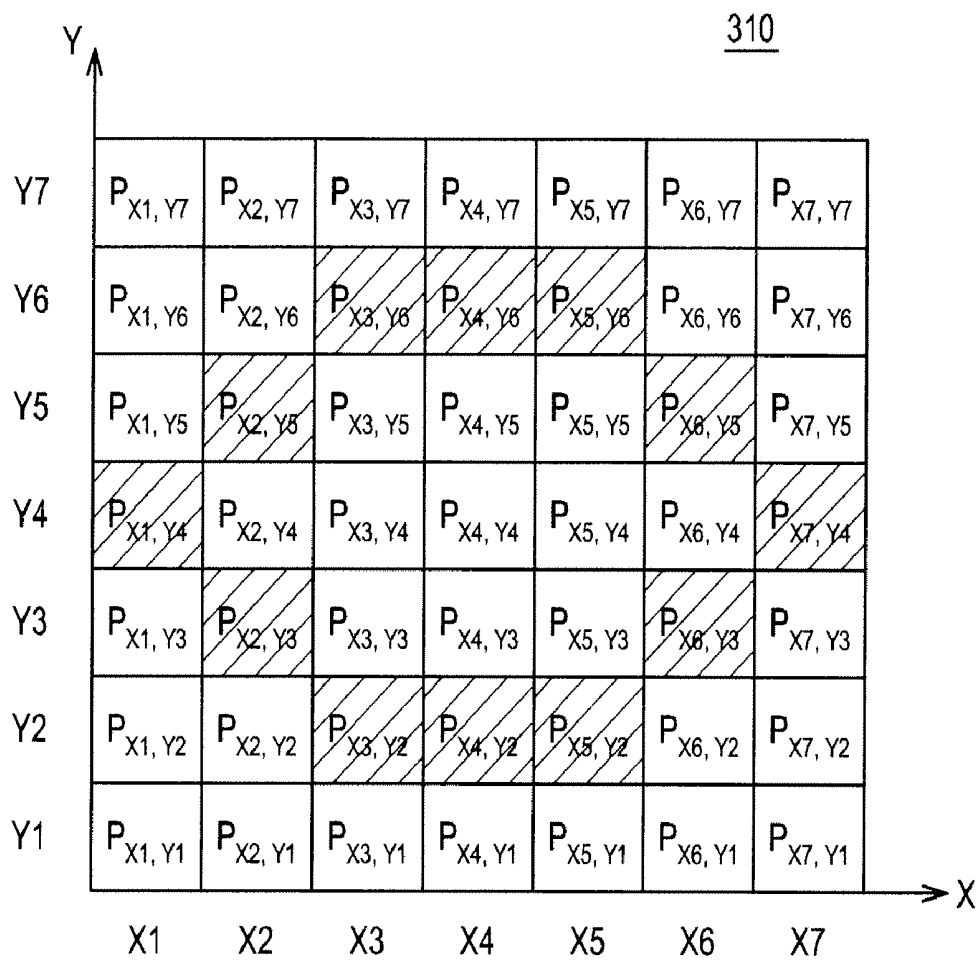

FIG. 7

320

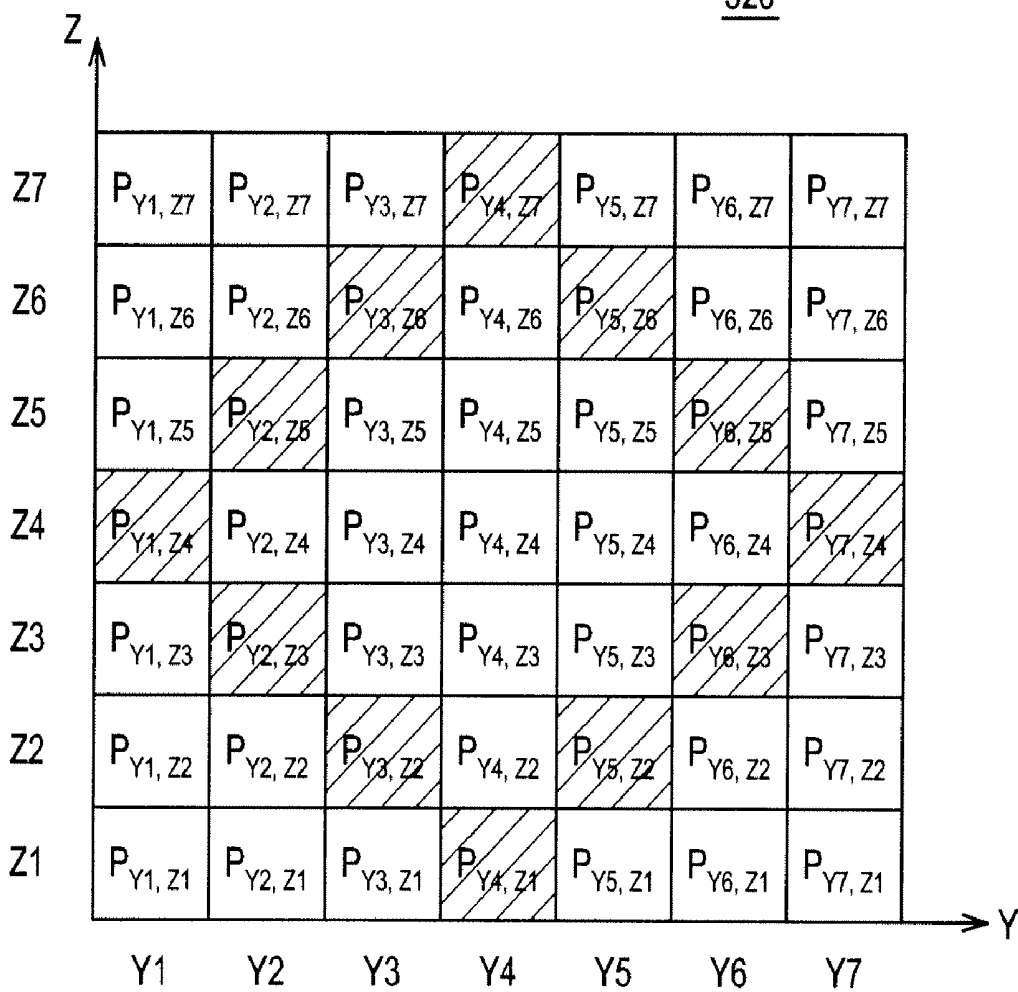
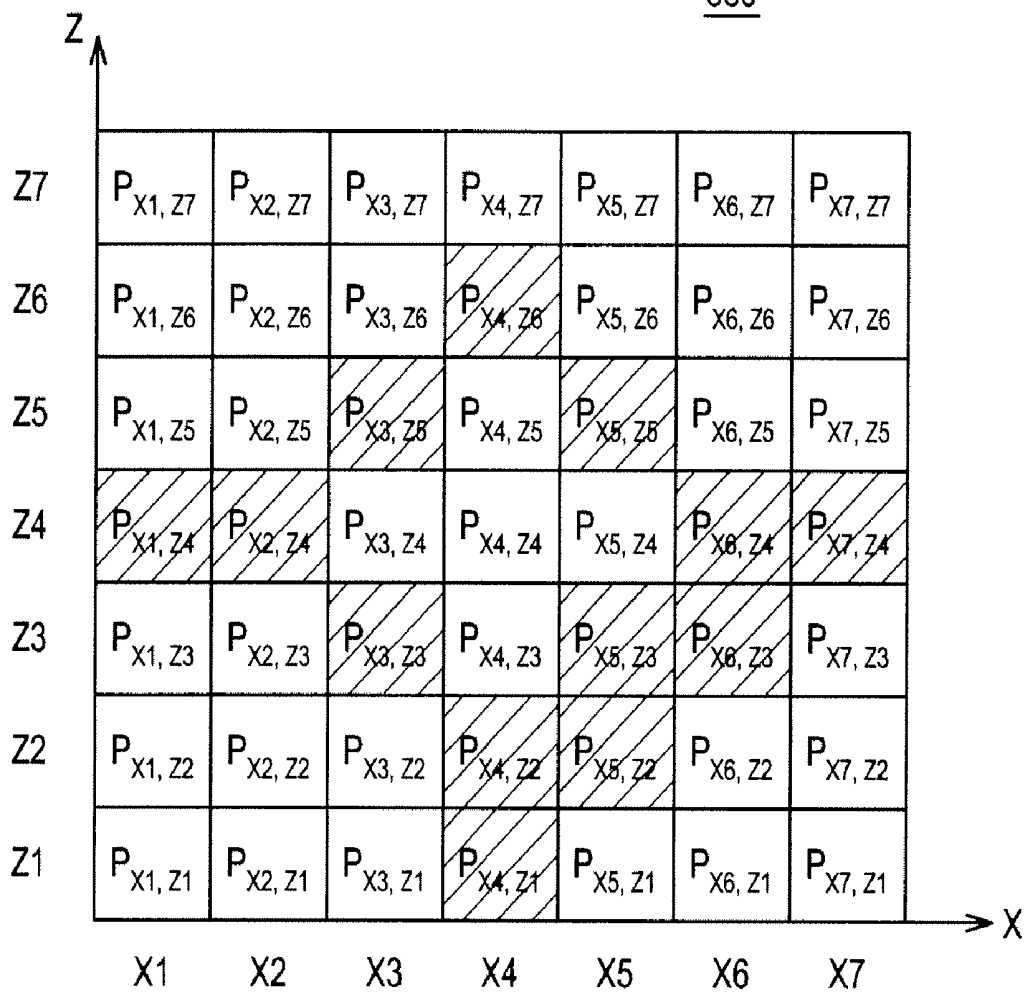

FIG. 8

330



ARRANGING A THREE-DIMENSIONAL ULTRASOUND IMAGE IN AN ULTRASOUND SYSTEM

CROSS-REFERENCE TO RELATED APPLICATIONS

[0001] The present application claims priority from Korean Patent Application No. 10-2009-0036300 filed on Apr. 27, 2009, the entire subject matter of which is incorporated herein by reference.

TECHNICAL FIELD

[0002] The present disclosure generally relates to ultrasound systems, and more particularly to arranging a 3D (three-dimensional) ultrasound image in an ultrasound system.

BACKGROUND

[0003] An ultrasound system has become an important and popular diagnostic tool since it has a wide range of applications. Specifically, due to its non-invasive and non-destructive nature, the ultrasound system has been extensively used in the medical profession. Modern high-performance ultrasound systems and techniques are commonly used to produce 2D (two-dimensional) or 3D (three-dimensional) ultrasound images of internal features of a target object (e.g., human organs).

[0004] The ultrasound system may provide the three-dimensional ultrasound image including clinical information such as spatial information and anatomical figures of the target object, which cannot be provided by the two-dimensional ultrasound image. The ultrasound system may transmit ultrasound signals into the target object, receive ultrasound echo signals reflected from the target objects and form volume data based on the ultrasound echo signals. The ultrasound system may further form the three-dimensional ultrasound image including the clinical information by rendering the volume data.

[0005] Generally, a position of the target object in the 3D ultrasound image is changed according to a position of an ultrasound probe, which transmits and receives ultrasound signals to and from the target object. Thus, there is a problem in that a user has to move or rotate the 3D ultrasound image in order to arrange the 3D ultrasound image.

SUMMARY

[0006] Embodiments for providing a plurality of slice images in an ultrasound system are disclosed herein. In one embodiment, by way of non-limiting example, an ultrasound system comprises: a storage unit for storing a plurality of reference position information each corresponding to a plurality of target objects; a user input unit configured to receive input information for selecting a target object; an ultrasound data acquisition unit configured to transmit and receive ultrasound signals to and from the target object to thereby output ultrasound data; and a processing unit in communication with the storage unit, the user input unit and the ultrasound data acquisition unit, the processing unit being configured to form a 3D ultrasound image based on the ultrasound data and perform position arrangement of the 3D ultrasound image based on reference position information corresponding to the input information.

[0007] In another embodiment, there is provided a method of arranging a 3D ultrasound image, comprising: a) receiving input information for selecting a target object; b) transmitting and receiving ultrasound signals to and from the target object to thereby output ultrasound data; c) forming a 3D ultrasound image based on the ultrasound data; and d) performing a position arrangement of the 3D ultrasound image based on reference position information corresponding to the input information, wherein the reference position information is stored in a storage unit corresponding to a plurality of target objects.

[0008] In yet another embodiment, there is provided a computer readable medium comprising computer executable instructions configured to perform the following acts: a) receiving input information for selecting a target object; b) transmitting and receiving ultrasound signals to and from the target object to thereby output ultrasound data; c) forming a 3D ultrasound image based on the ultrasound data; and d) performing a position arrangement of the 3D ultrasound image based on reference position information corresponding to the input information, wherein the reference position information is stored in a storage unit corresponding to a plurality of target objects.

[0009] The Summary is provided to introduce a selection of concepts in a simplified form that are further described below in the Detailed Description. This Summary is not intended to identify key or essential features of the claimed subject matter, nor is it intended to be used in determining the scope of the claimed subject matter.

BRIEF DESCRIPTION OF THE DRAWINGS

[0010] FIG. 1 is a block diagram showing an illustrative embodiment of an ultrasound system.

[0011] FIG. 2 is a block diagram showing an illustrative embodiment of an ultrasound data acquisition unit.

[0012] FIG. 3 is a schematic diagram showing an example of acquiring ultrasound data corresponding to a plurality of frames.

[0013] FIG. 4 is a block diagram showing an illustrative embodiment of a processing unit.

[0014] FIG. 5 is a schematic diagram showing an example of projecting a 3D ultrasound image to an XY plane, a YZ plane and an XZ plane.

[0015] FIG. 6 is a schematic diagram showing an example of a 2D projection image of the XY plane.

[0016] FIG. 7 is a schematic diagram showing an example of a 2D projection image of the YZ plane.

[0017] FIG. 8 is a schematic diagram showing an example of a 2D projection image of the XZ plane.

DETAILED DESCRIPTION

[0018] A detailed description may be provided with reference to the accompanying drawings. One of ordinary skill in the art may realize that the following description is illustrative only and is not in any way limiting. Other embodiments of the present invention may readily suggest themselves to such skilled persons having the benefit of this disclosure.

[0019] An ultrasound system 100 in accordance with an illustrative embodiment is shown in FIG. 1. As depicted therein, the ultrasound system 100 may include a user input unit 110. The user input unit 110 may receive input information from a user. The input information may be information for selecting a target object to form a 3D (three-dimensional)

ultrasound image from a subject (e.g., a patient). The target object may include a heart, a liver, a blood vessel, a lesion or the like. However, the target object may not be limited thereto. The user input unit **110** may include a control panel, a mouse, a keyboard or the like, although it may not be limited thereto.

[0020] The ultrasound system **100** may further include a storage unit **120**. The storage unit **120** may store a plurality of reference position information each corresponding to a plurality of target objects. The reference position information may be information for arranging the 3D ultrasound image to a predetermined position. In one embodiment, the reference position information may include a plurality of predetermined pixel distances between pixels corresponding to contour points of the target object. The storage unit **120** may store a mapping table providing the plurality of reference position information each corresponding to a plurality of target objects.

[0021] The ultrasound system **100** may further include an ultrasound data acquisition unit **130**. The ultrasound data acquisition unit **130** may transmit and receive ultrasound signals to and from a target object to thereby output ultrasound data. The ultrasound data acquisition unit **130** may include a transmit (Tx) signal generating section **131**, as shown in FIG. 2.

[0022] Referring to FIG. 2, the Tx signal generating section **131** may be configured to generate Tx signals. The Tx signal generating section **131** may perform the generation of the Tx signals at every predetermined time to thereby form a plurality of Tx signals for obtaining each of frames F_i ($1 \leq i \leq N$) representing the target object, as shown in FIG. 3. The frames F_i ($1 \leq i \leq N$) may represent a plurality of sectional planes of the target object.

[0023] The ultrasound data acquisition unit **130** may further include an ultrasound probe **132** containing a plurality of elements for reciprocally converting between ultrasound signals and electrical signals. The ultrasound probe **132** may be configured to transmit ultrasound signals into the target object in response to the Tx signals. The ultrasound probe **132** may further receive echo signals reflected from the target object to thereby output received signals. The received signals may be analog signals. The ultrasound probe **132** may include a three-dimensional mechanical probe, a two-dimensional array probe or the like.

[0024] The ultrasound data acquisition unit **130** may further include a beam former **133**. The beam former **133** may convert the received signals into digital signals. The beam former **133** may further apply delays to the digital signals in consideration of distances between the plurality of elements of the ultrasound probe **132** and focal points to thereby output digital receive-focused signals.

[0025] The ultrasound data acquisition unit **130** may further include an ultrasound data forming section **134**. The ultrasound data forming section **134** may form ultrasound data corresponding to each of the frames F_i ($1 \leq i \leq N$) based on the digital receive-focused signals.

[0026] Referring back to FIG. 1, the ultrasound system **100** may further include a processing unit **140**, which may be coupled to the user input unit **110**, the storage unit **120** and the ultrasound data acquisition unit **130**. FIG. 4 is a block diagram showing an illustrative embodiment of the processing unit **140**. Referring to FIG. 4, the processing unit **140** may include a volume data forming section **141**, an image forming section **142**, a plane setting section **143**, a projecting section **144**, a contour point detecting section **145**, a position infor-

mation forming section **146**, a skewness calculating section **147** and an arranging section **148**.

[0027] The volume data forming section **141** may synthesize the ultrasound data corresponding to the frames F_i ($1 \leq i \leq N$) to thereby form volume data including the frames F_i ($1 \leq i \leq N$). The volume data may include a plurality of voxels having brightness values.

[0028] The image forming section **142** may render the volume data provided from the volume data forming section **141** to thereby form the 3D ultrasound image. The methods of rendering the volume data are well known in the art. Thus, they have not been described in detail so as not to unnecessarily obscure the present invention.

[0029] The plane setting section **143** may set a plurality of planes for projecting the 3D ultrasound image. In one embodiment, the plane setting section **143** may set an XY plane **310**, a YZ plane **320** and an XZ plane **330** for projecting the 3D ultrasound image **210**, as shown in FIG. 5. In FIG. 5, reference numeral **220** represents the target object.

[0030] The projecting section **144** may project the 3D ultrasound image to the XY plane **310**, the YZ plane **320** and the XZ plane **330** to thereby form 2D (two-dimensional) projection images on the XY plane **310**, the YZ plane **320** and the XZ plane **330**. The methods of projecting the 3D ultrasound image are well known in the art. Thus, they have not been described in detail so as not to unnecessarily obscure the present invention.

[0031] The contour point detecting section **145** may detect contour points of the target object in the 2D projection images of the XY plane **310**, the YZ plane **320** and the XZ plane **330**. The contour point may be detected by using an edge mask such as Sobel, Prewitt, Robert, Canny mask or the like. The contour point may be detected based on the differences between eigenvalues using structure tensors.

[0032] The position information forming section **146** may calculate pixel distances between pixels corresponding to the detected contour points to thereby form position information including the pixel distances.

[0033] In one embodiment, the position information forming section **146** may calculate pixel distances between the pixels $P_{X1,Y4}$, $P_{X2,Y3}$, $P_{X2,Y5}$, $P_{X3,Y2}$, $P_{X3,Y6}$, $P_{X4,Y2}$, $P_{X4,Y6}$, $P_{X5,Y2}$, $P_{X5,Y6}$, $P_{X6,Y3}$, $P_{X6,Y5}$ and $P_{X7,Y4}$ corresponding to the detected contour points in the 2D projection image of the XY plane **310**, as shown in FIG. 6. More particularly, the position information forming section **146** may calculate pixel distance ($D_{X2}=2$) between pixels $P_{X2,Y3}$ and $P_{X2,Y5}$ located in X2, pixel distance ($D_{X3}=4$) between pixels $P_{X3,Y2}$ and $P_{X3,Y6}$ located in X3, pixel distance ($D_{X4}=4$) between pixels $P_{X4,Y2}$ and $P_{X4,Y6}$ located in X4, pixel distance ($D_{X5}=4$) between pixels $P_{X5,Y2}$ and $P_{X5,Y6}$ located in X5, and pixel distance ($D_{X6}=2$) between pixels $P_{X6,Y3}$ and $P_{X6,Y5}$ located in X6. Also, the position information forming section **146** may further calculate pixel distance ($D_{Y21}=1$) between pixels $P_{X3,Y7}$ and $P_{X4,Y2}$ located in Y2, pixel distance ($D_{Y22}=1$) between pixels $P_{X4,Y2}$ and $P_{X5,Y2}$ located in Y2, pixel distance ($D_{Y23}=2$) between pixels $P_{X3,Y2}$ and $P_{X5,Y2}$ located in Y2, pixel distance ($D_{Y3}=4$) between pixels $P_{X2,Y3}$ and $P_{X6,Y3}$ located in Y3, pixel distance ($D_{Y4}=6$) between pixels $P_{X1,Y4}$ and $P_{X7,Y4}$ located in Y4, pixel distance ($D_{Y5}=4$) between pixels $P_{X2,Y5}$ and $P_{X6,Y5}$ located in Y5, pixel distance ($D_{Y61}=1$) between pixels $P_{X3,Y6}$ and $P_{X4,Y6}$ located in Y6, pixel distance ($D_{Y62}=1$) between pixels $P_{X4,Y6}$ and $P_{X5,Y6}$ located in Y6, and pixel distance ($D_{Y63}=2$) between pixels $P_{X3,Y6}$ and $P_{X5,Y6}$ located in Y6.

[0034] Similarly, the position information forming section **146** may further calculate pixel distances between the pixels $P_{Y1,Z4}$, $P_{Y2,Z3}$, $P_{Y2,Z5}$, $P_{Y3,Z2}$, $P_{Y3,Z6}$, $P_{Y4,Z1}$, $P_{Y4,Z7}$, $P_{Y5,Z2}$, $P_{Y5,Z6}$, $P_{Y6,Z3}$, $P_{Y6,Z5}$ and $P_{Y7,Z4}$ corresponding to the detected contour points in the 2D projection image of the YZ plane **320**, as shown in FIG. 7. Also, the position information forming section **146** may further calculate pixel distances between the pixels $P_{X1,Z4}$, $P_{X2,Z4}$, $P_{X3,Z3}$, $P_{X3,Z5}$, $P_{X4,Z1}$, $P_{X4,Z2}$, $P_{X4,Z6}$, $P_{X5,Z2}$, $P_{X5,Z3}$, $P_{X5,Z5}$, $P_{X6,Z3}$, $P_{X6,Z4}$ and $P_{X7,Z4}$ corresponding to the detected contour points in the 2D projection image of the XZ plane **330**, as shown in FIG. 8. The position information forming section **146** may form the position information including the calculated pixel distances.

[0035] The skewness calculating section **147** may retrieve reference position information corresponding to the input information from the storage unit **120**. The skewness calculating section **147** may further calculate skewness based on the position information and the retrieved reference position information to thereby form skewness information. In one embodiment, the skewness calculating section **147** may calculate skewness between the pixel distances of the position information and the predetermined pixel distances of the retrieved reference position information to thereby form the skewness information. However, the methods of calculating the skewness may not be limited thereto.

[0036] The arranging section **148** may perform a position arrangement of the 3D ultrasound image based on the skewness information provided from the skewness calculating section **147**. In one embodiment, the arranging section **148** may compare the skewness of the skewness information with a predetermined threshold value. If the skewness is larger than the threshold value, then the arranging section **148** may calculate difference between the skewness and the threshold value. The arranging section **148** may further perform the position arrangement of the 3D ultrasound image by moving or rotating the 3D ultrasound image based on the calculated difference.

[0037] The projecting section **144**, the contour point detecting section **145**, the position information forming section **146**, the skewness calculating section **147** and the arranging section **148** of the processing unit **140** may perform the position arrangement of the 3D ultrasound image until the skewness is smaller than the threshold value. That is, the 3D ultrasound image is arranged to the predetermined position.

[0038] Referring back to FIG. 1, the ultrasound system **100** may further include a display unit **150**. The display unit **150** may display the 3D ultrasound image.

[0039] In another embodiment, the present invention may provide a computer readable medium comprising computer executable instructions configured to perform following acts: a) receiving input information for selecting a target object; b) transmitting and receiving ultrasound signals to and from the target object to thereby output ultrasound data; c) forming a 3D ultrasound image based on the ultrasound data; and d) performing a position arrangement of the 3D ultrasound image based on reference position information corresponding to the input information, wherein the reference position information is stored in a storage unit corresponding to a plurality of target objects. The computer readable medium may comprise a floppy disk, a hard disk, a memory, a compact disk, a digital video disk, etc.

[0040] Although embodiments have been described with reference to a number of illustrative embodiments thereof, it should be understood that numerous other modifications and

embodiments can be devised by those skilled in the art that will fall within the spirit and scope of the principles of this disclosure. More particularly, numerous variations and modifications are possible in the component parts and/or arrangements of the subject combination arrangement within the scope of the disclosure, the drawings and the appended claims. In addition to variations and modifications in the component parts and/or arrangements, alternative uses will also be apparent to those skilled in the art.

What is claimed is:

1. An ultrasound system, comprising:

a storage unit for storing a plurality of reference position information each corresponding to a plurality of target objects;

a user input unit configured to receive input information for selecting a target object;

an ultrasound data acquisition unit configured to transmit and receive ultrasound signals to and from the target object to thereby output ultrasound data; and

a processing unit in communication with the storage unit, the user input unit and the ultrasound data acquisition unit, the processing unit being configured to form a 3D ultrasound image based on the ultrasound data and perform position arrangement of the 3D ultrasound image based on reference position information corresponding to the input information.

2. The ultrasound system of claim **1**, wherein the processing unit comprises:

a volume data forming section configured to form volume data based on the ultrasound data;

an image forming section configured to render the volume data to thereby form the 3D ultrasound image;

a plane setting section configured to set a plurality of planes for projecting the 3D ultrasound image;

a projecting section configured to project the 3D ultrasound image to the plurality of planes to thereby form 2D (two-dimensional) projection images;

a contour point detecting section configured to detect contour points of the target object in the 2D projection images;

a position information forming section configured to calculate pixel distances between pixels corresponding to the detected contour points to thereby form position information including the calculated pixel distances;

a skewness calculating section configured to retrieve the reference position information corresponding to the input information from the storage unit and calculate skewness based on the reference position information and the position information to thereby form skewness information; and

an arranging section configured to perform the position arrangement of the 3D ultrasound image based on the skewness information.

3. The ultrasound system of claim **2**, wherein the planes comprise an XY plane, a YZ plane and an XZ plane.

4. The ultrasound system of claim **3**, wherein the position information forming section is configured to calculate a plurality of first pixel distances between pixels corresponding to the detected contour points in the 2D projection image of the XY plane, calculate a plurality of second pixel distances between pixels corresponding to the detected contour points in the 2D projection image of the YZ plane, calculate a plurality of third pixel distances between pixels corresponding to the detected contour points in the 2D projection image of the

XZ plane and form the position information including the plurality of first, second and third pixel distances.

5. The ultrasound system of claim 4, wherein the reference position information comprises a plurality of predetermined pixel distances between pixels corresponding to contour points of the target object.

6. The ultrasound system of claim 5, wherein the skewness calculating section is configured to calculate the skewness between the plurality of first, second and third pixel distances of the position information and the plurality of predetermined pixel distances of the reference position information.

7. The ultrasound system of claim 6, wherein the arranging section is configured to compare the skewness of the skewness information with a predetermined threshold value, calculate difference between the skewness and the threshold value when the skewness is larger than the threshold value, and move or rotate the 3D ultrasound image based on the calculated difference.

8. A method of arranging a 3D (three-dimensional) ultrasound image, comprising:

- a) receiving input information for selecting a target object;
- b) transmitting and receiving ultrasound signals to and from the target object to thereby output ultrasound data;
- c) forming a 3D ultrasound image based on the ultrasound data; and
- d) performing a position arrangement of the 3D ultrasound image based on reference position information corresponding to the input information, wherein the reference position information is stored in a storage unit corresponding to a plurality of target objects.

9. The method of claim 8, wherein the step d) comprises:

- d1) setting a plurality of planes for projecting the 3D ultrasound image;
- d2) projecting the 3D ultrasound image to the plurality of planes to thereby form 2D (two-dimensional) projection images;
- d3) detecting contour points of the target object in the 2D projection images;
- d4) calculating pixel distances between pixels corresponding to the detected contour points to thereby form position information including the calculated pixel distances;
- d5) retrieving the reference position information corresponding to the input information from the storage unit;
- d6) calculating a skewness based on the reference position information and the position information to thereby form skewness information; and
- d7) performing the position arrangement of the 3D ultrasound image based on the skewness information.

10. The method of claim 9, wherein the planes comprise an XY plane, a YZ plane and an XZ plane.

11. The method of claim 10, wherein the step d4) comprises:

- calculating a plurality of first pixel distances between pixels corresponding to the contour points in the 2D projection image of the XY plane;
- calculating a plurality of second pixel distances between pixels corresponding to the contour points in the 2D projection image of the YZ plane;
- calculating a plurality of third pixel distances between pixels corresponding to the contour points in the 2D projection image of the XZ plane; and
- forming the position information including the plurality of first, second and third pixel distances.

12. The method of claim 11, wherein the reference position information comprises a plurality of predetermined pixel distances between pixels corresponding to contour points of the target object.

13. The method of claim 12, wherein the step d6) comprises:

- calculating skewness between the plurality of first, second and third pixel distances of the position information and the plurality of predetermined pixel distances of the reference position information.

14. The method of claim 13, wherein the step d7) comprises:

- comparing the skewness of the skewness information with a predetermined threshold value;
- calculating difference between the skewness and the threshold value when the skewness is larger than the threshold value; and
- moving or rotating the 3D ultrasound image based on the calculated difference.

15. A computer readable medium comprising computer executable instructions configured to perform following acts:

- a) receiving input information for selecting a target object;
- b) transmitting and receiving ultrasound signals to and from the target object to thereby output ultrasound data;
- c) forming a 3D ultrasound image based on the ultrasound data; and
- d) performing a position arrangement of the 3D ultrasound image based on reference position information corresponding to the input information, wherein the reference position information is stored in a storage unit corresponding to a plurality of target objects.

* * * * *

专利名称(译)	在超声系统中安排三维超声图像		
公开(公告)号	US20100274132A1	公开(公告)日	2010-10-28
申请号	US12/729047	申请日	2010-03-22
[标]申请(专利权)人(译)	KIM CHUL AN 金圣YOON 李成MO		
申请(专利权)人(译)	KIM CHUL AN 金圣YOON 李成MO		
当前申请(专利权)人(译)	三星MEDISON CO. , LTD.		
[标]发明人	KIM CHUL AN KIM SUNG YOON LEE SUNG MO		
发明人	KIM, CHUL AN KIM, SUNG YOON LEE, SUNG MO		
IPC分类号	A61B8/14 G06K9/00 A61B8/00		
CPC分类号	A61B8/483 G01S15/8993 G06T7/0046 G06T2219/008 G06T2207/10136 G06T2207/30004 G06T15/08 G06T19/00 G06T7/75		
优先权	1020090036300 2009-04-27 KR		
其他公开文献	US9366757		
外部链接	Espacenet USPTO		

摘要(译)

公开了用于布置3D (三维) 超声图像的实施例。在一个实施例中，作为非限制性示例，超声系统包括：存储单元，用于存储多个参考位置信息，每个参考位置信息对应于多个目标对象;用户输入单元，被配置为接收用于选择目标对象的输入信息;超声数据获取单元，被配置为向目标对象发送超声信号和从目标对象接收超声信号，从而输出超声数据;处理单元，用于与存储单元，用户输入单元和超声数据获取单元通信，处理单元被配置为基于超声数据形成3D超声图像，并基于参考执行3D超声图像的位置布置与输入信息对应的位置信息。

