



US 20180235574A1

(19) **United States**

(12) **Patent Application Publication**
MORIMOTO

(10) **Pub. No.: US 2018/0235574 A1**

(43) **Pub. Date: Aug. 23, 2018**

(54) **ULTRASONIC ARRAY OSCILLATOR,
METHOD OF PRODUCING ULTRASONIC
ARRAY OSCILLATOR, ULTRASONIC
PROBE, AND ULTRASONIC DIAGNOSTIC
APPARATUS**

Publication Classification

(51) **Int. Cl.**
A61B 8/00 (2006.01)
B06B 1/02 (2006.01)
B06B 1/06 (2006.01)
(52) **U.S. Cl.**
CPC *A61B 8/4455* (2013.01); *A61B 8/4281*
(2013.01); *B06B 1/0622* (2013.01); *B06B*
1/0207 (2013.01); *A61B 8/4483* (2013.01)

(71) Applicant: **SONY CORPORATION, TOKYO (JP)**

(72) Inventor: **RUI MORIMOTO, KANAGAWA (JP)**

(21) Appl. No.: **15/752,911**

(22) PCT Filed: **Jun. 16, 2016**

(86) PCT No.: **PCT/JP2016/002905**

§ 371 (c)(1),

(2) Date: **Feb. 15, 2018**

(30) **Foreign Application Priority Data**

Sep. 7, 2015 (JP) 2015-175699

(57) **ABSTRACT**

[Object] To provide an ultrasonic array oscillator, a method of producing an ultrasonic array oscillator, an ultrasonic probe, and an ultrasonic diagnostic apparatus having a high impedance matching effect and excellent productivity. [Solving Means] The ultrasonic array oscillator according to the present technology includes ultrasonic oscillators (130) and semiconductor chips (140). The ultrasonic oscillators (130) form an array. The semiconductor chips (140) are bonded to the respective ultrasonic oscillators (130) to form impedance matching circuits.

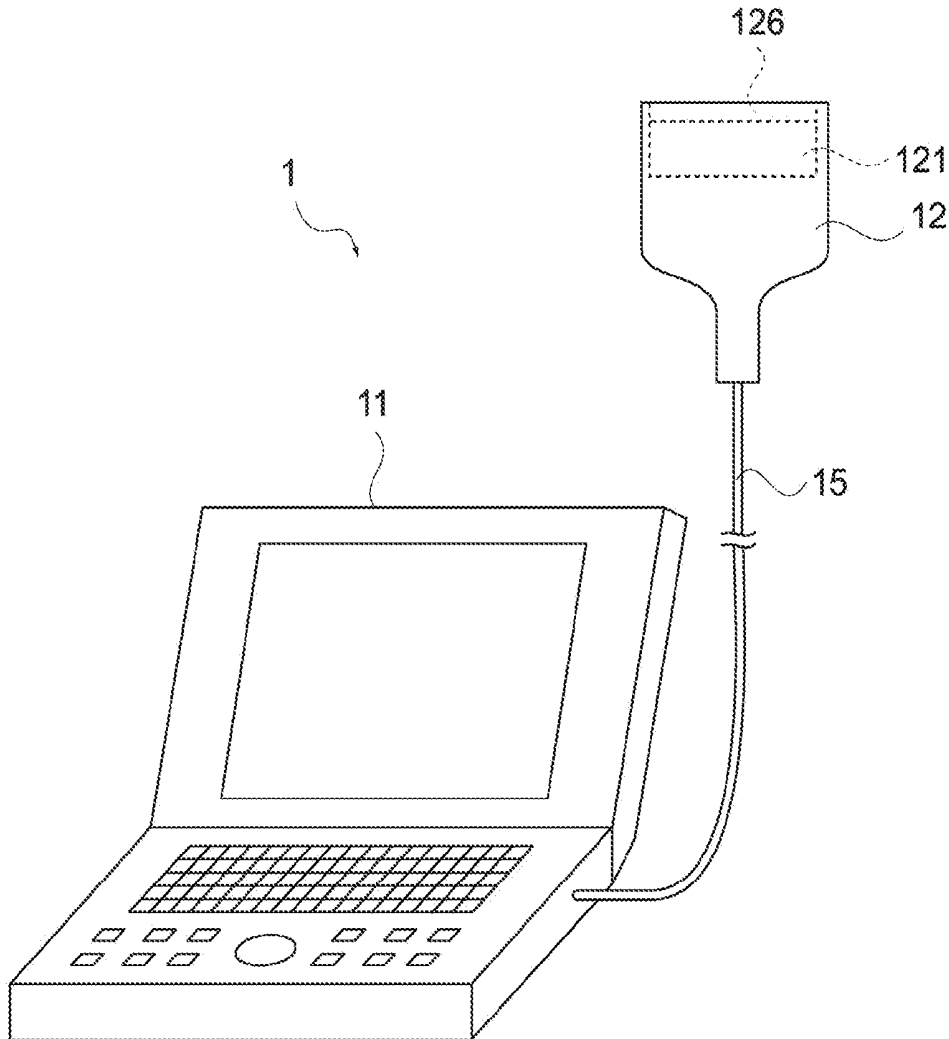

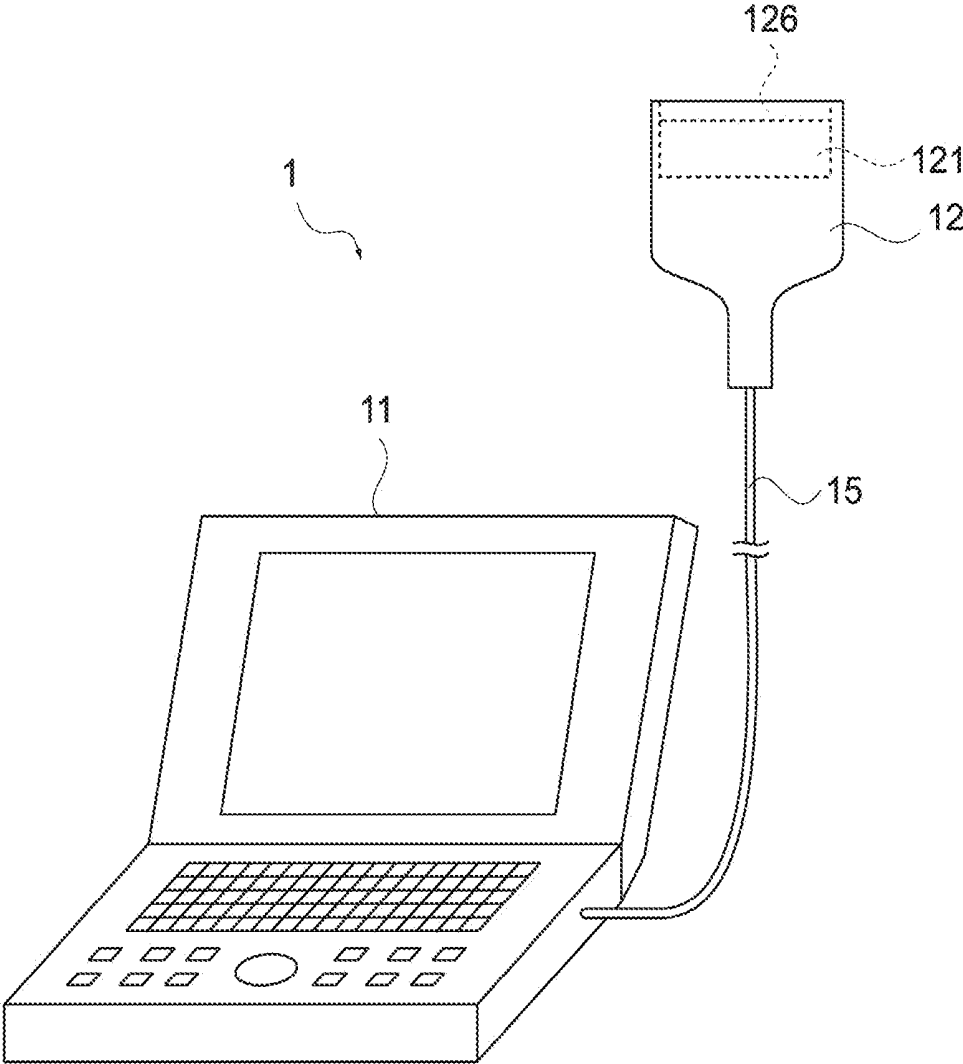

FIG.1

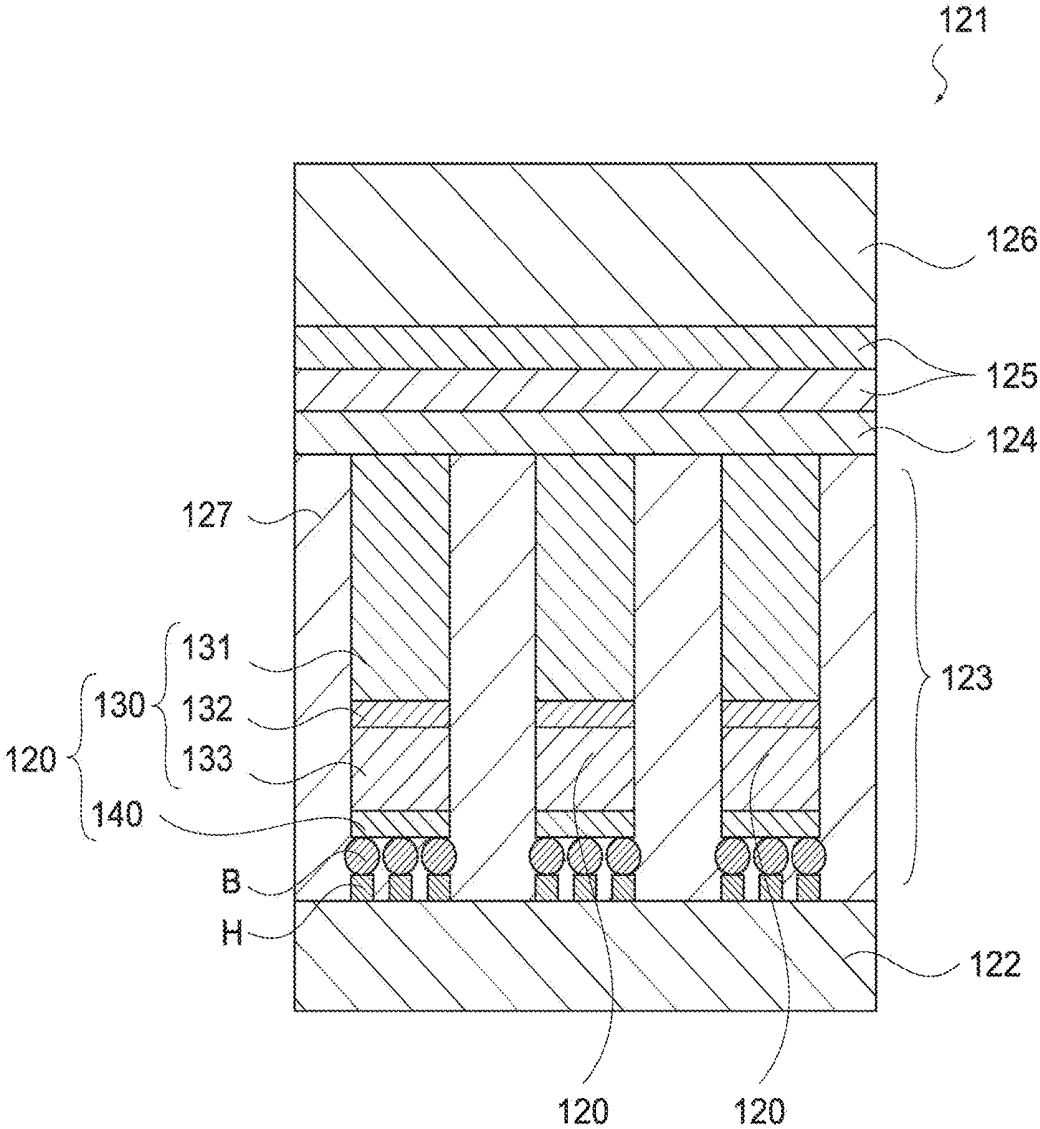

FIG.2

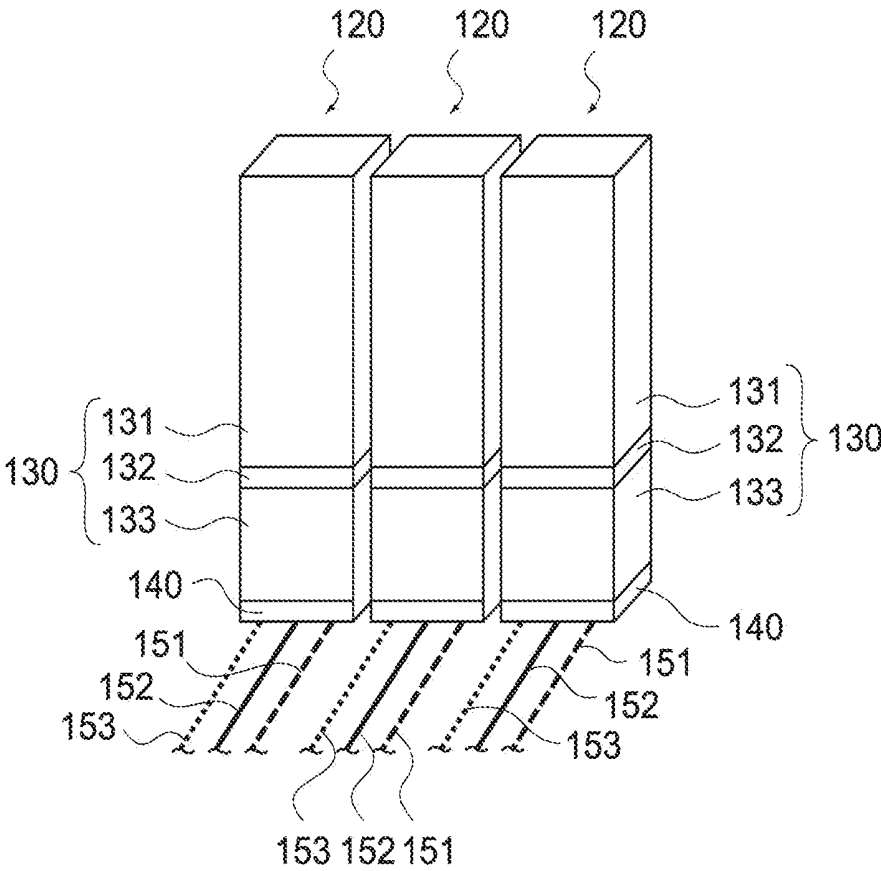

FIG.3

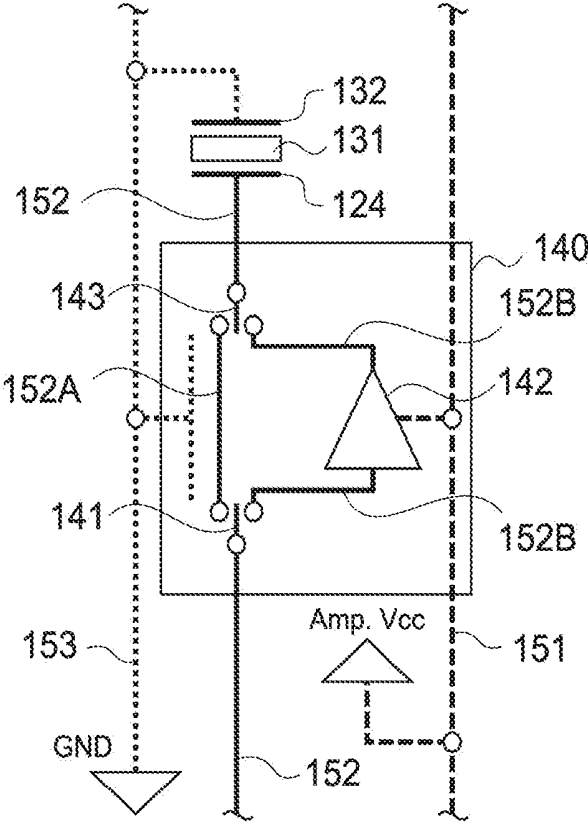

FIG.4

FIG. 5(a)

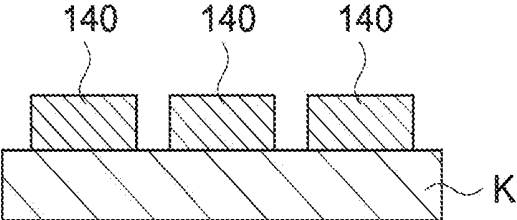

FIG. 5(b)

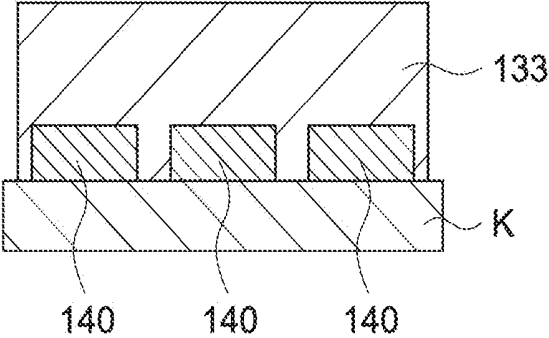
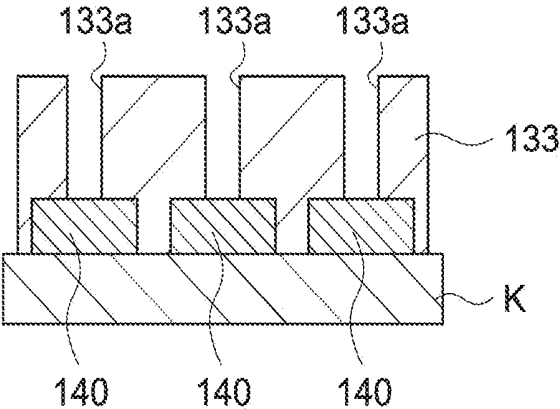
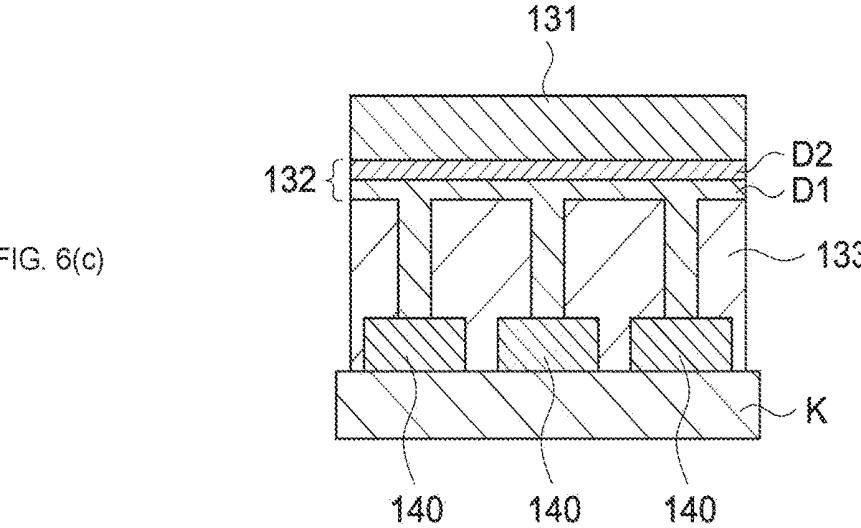
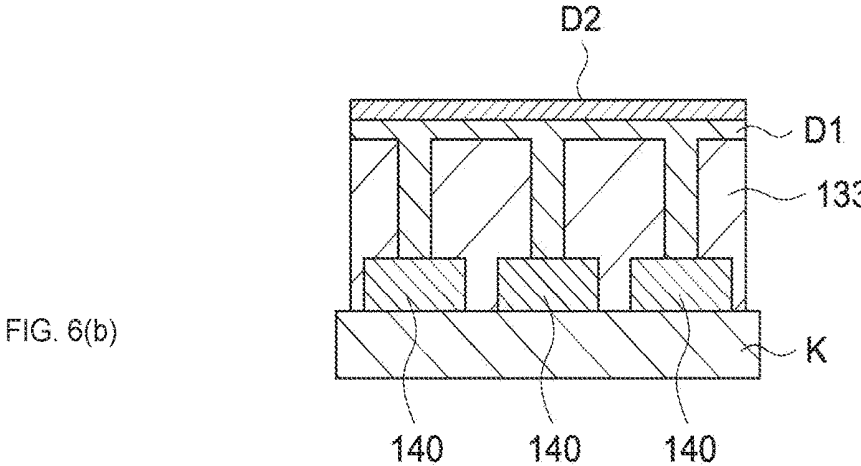
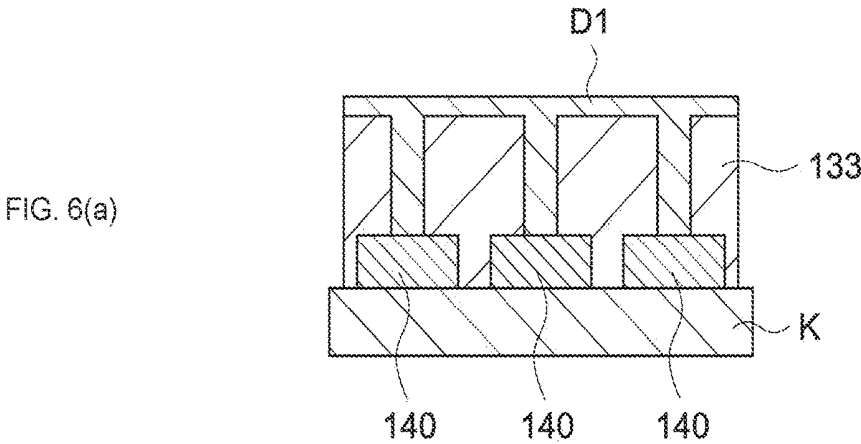

FIG. 5(c)





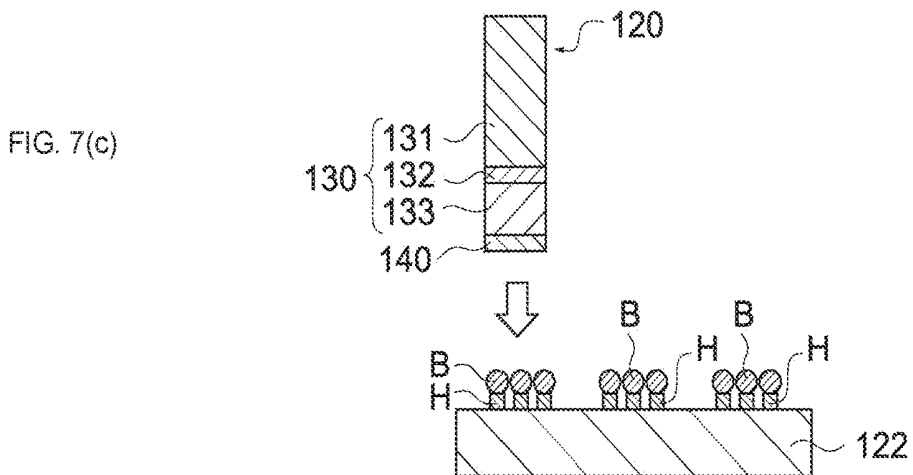
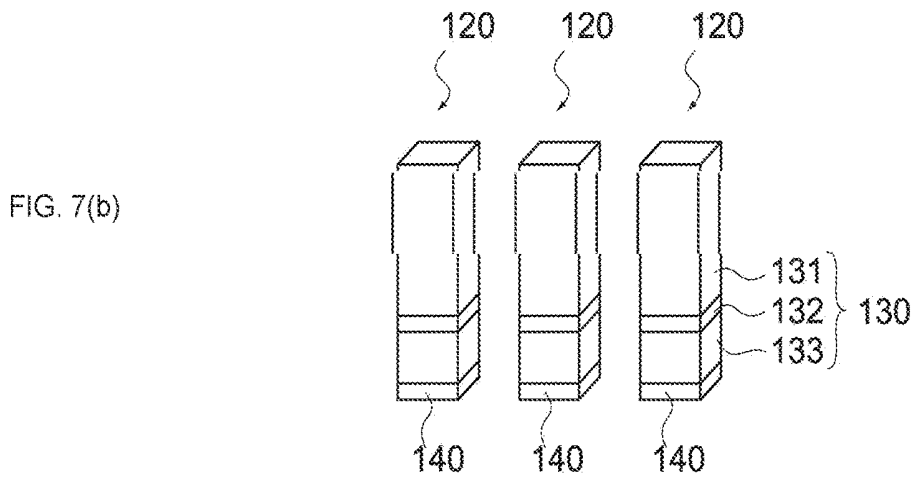
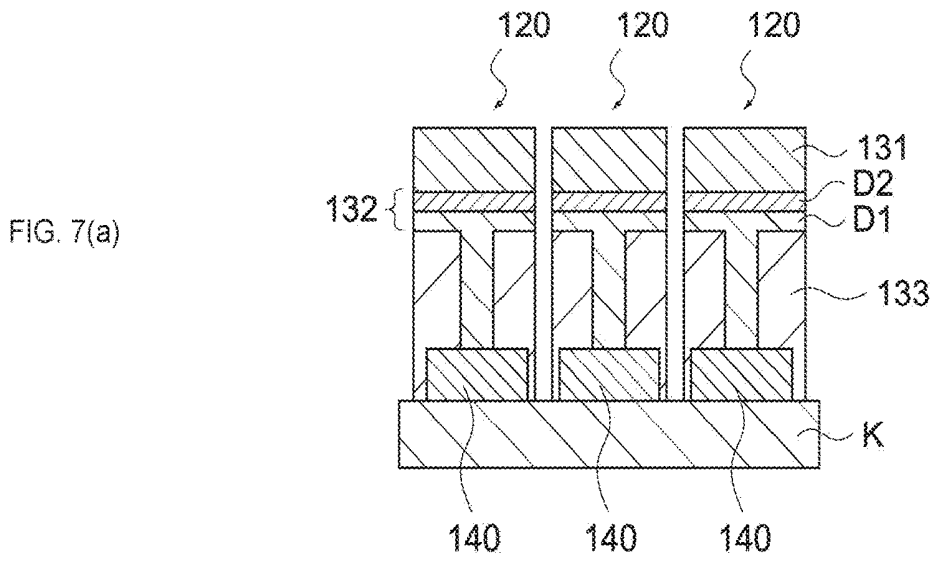

FIG. 8(a)

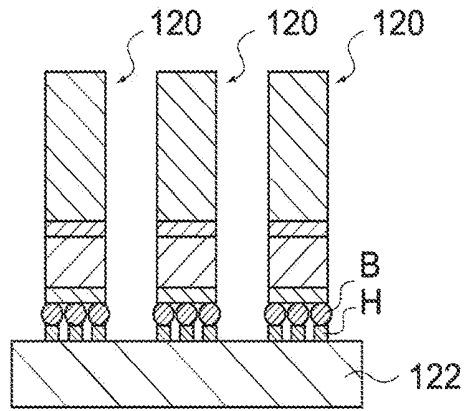

FIG. 8(b)

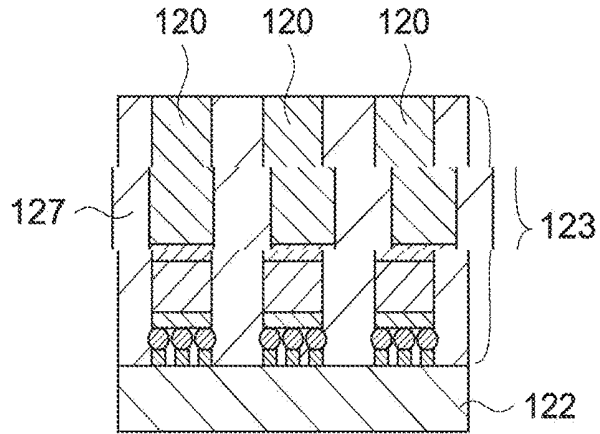
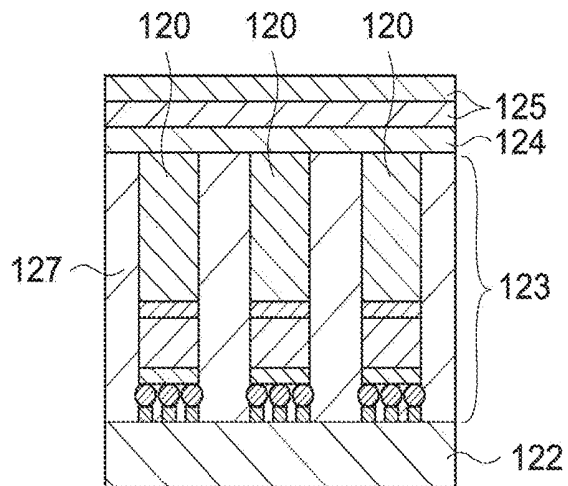

FIG. 8(c)



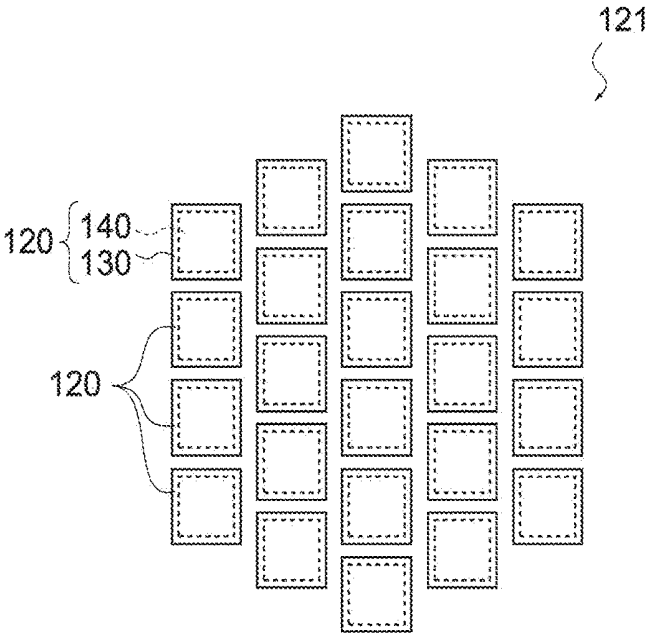
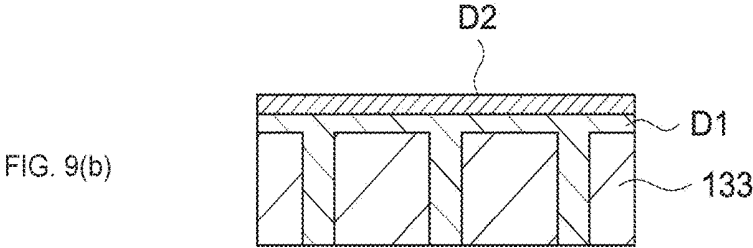
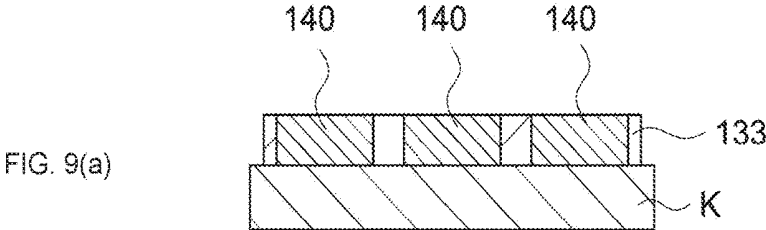

FIG.10

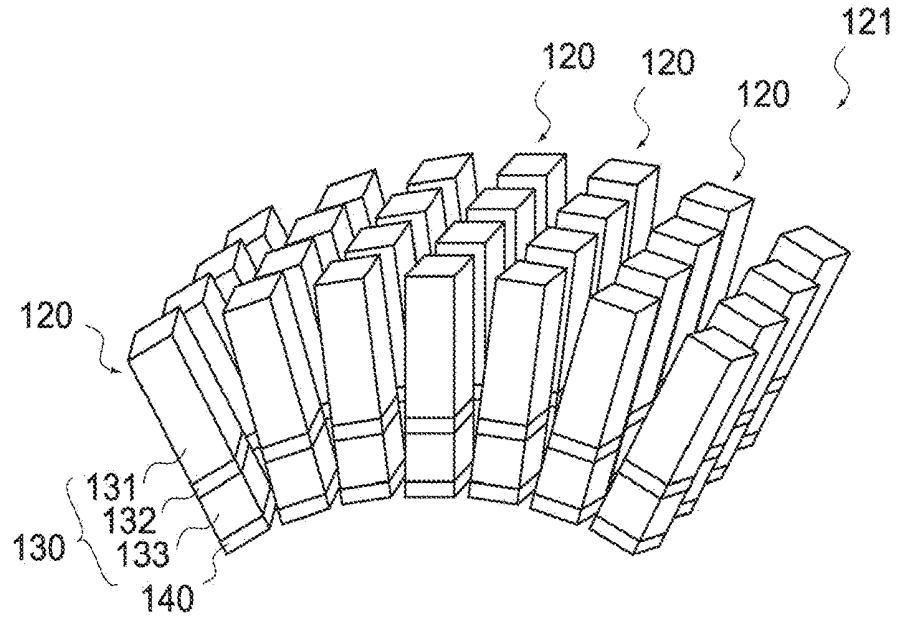

FIG.11

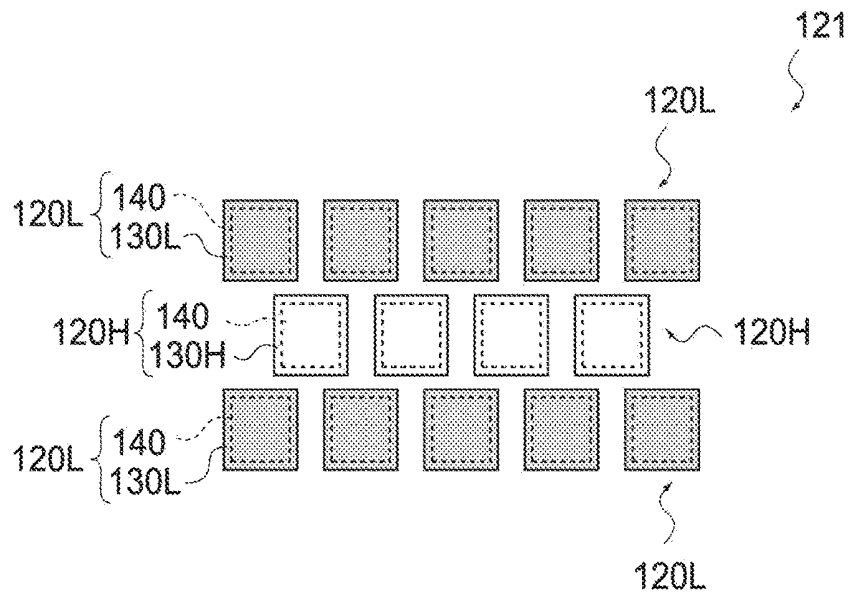

FIG.12

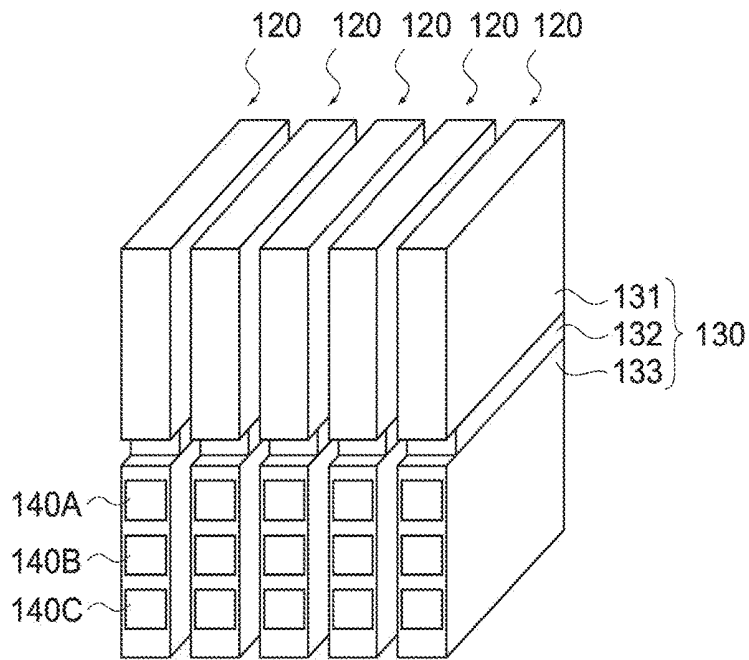

FIG.13

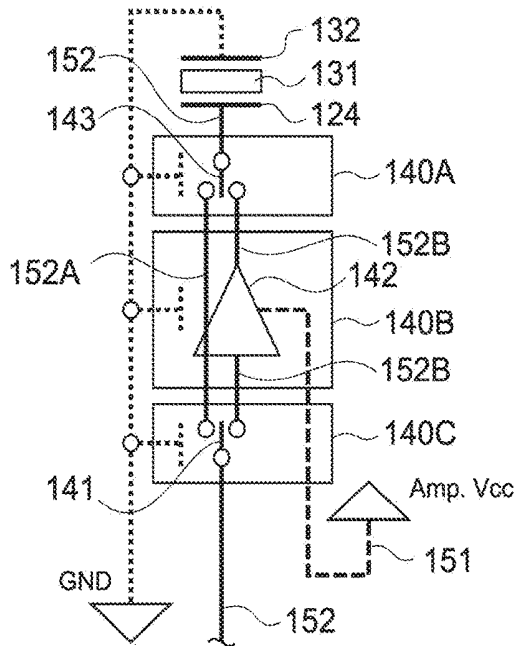

FIG.14

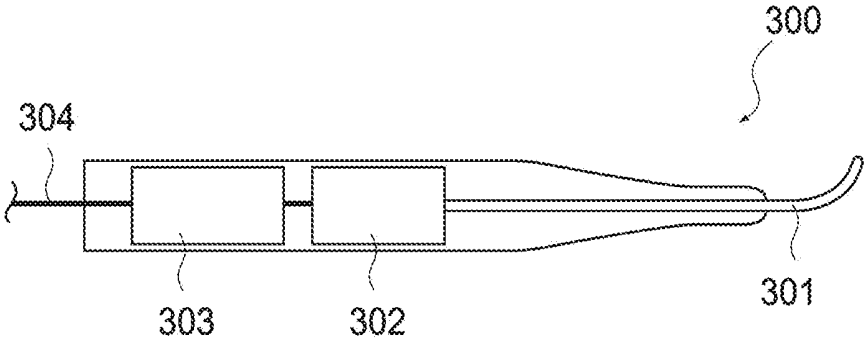

FIG. 15

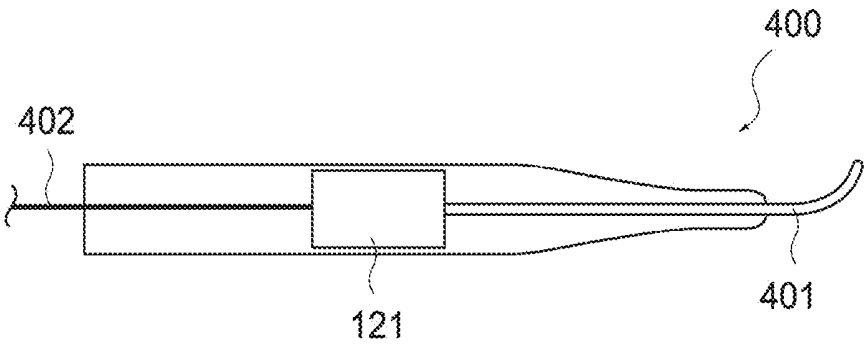

FIG. 16

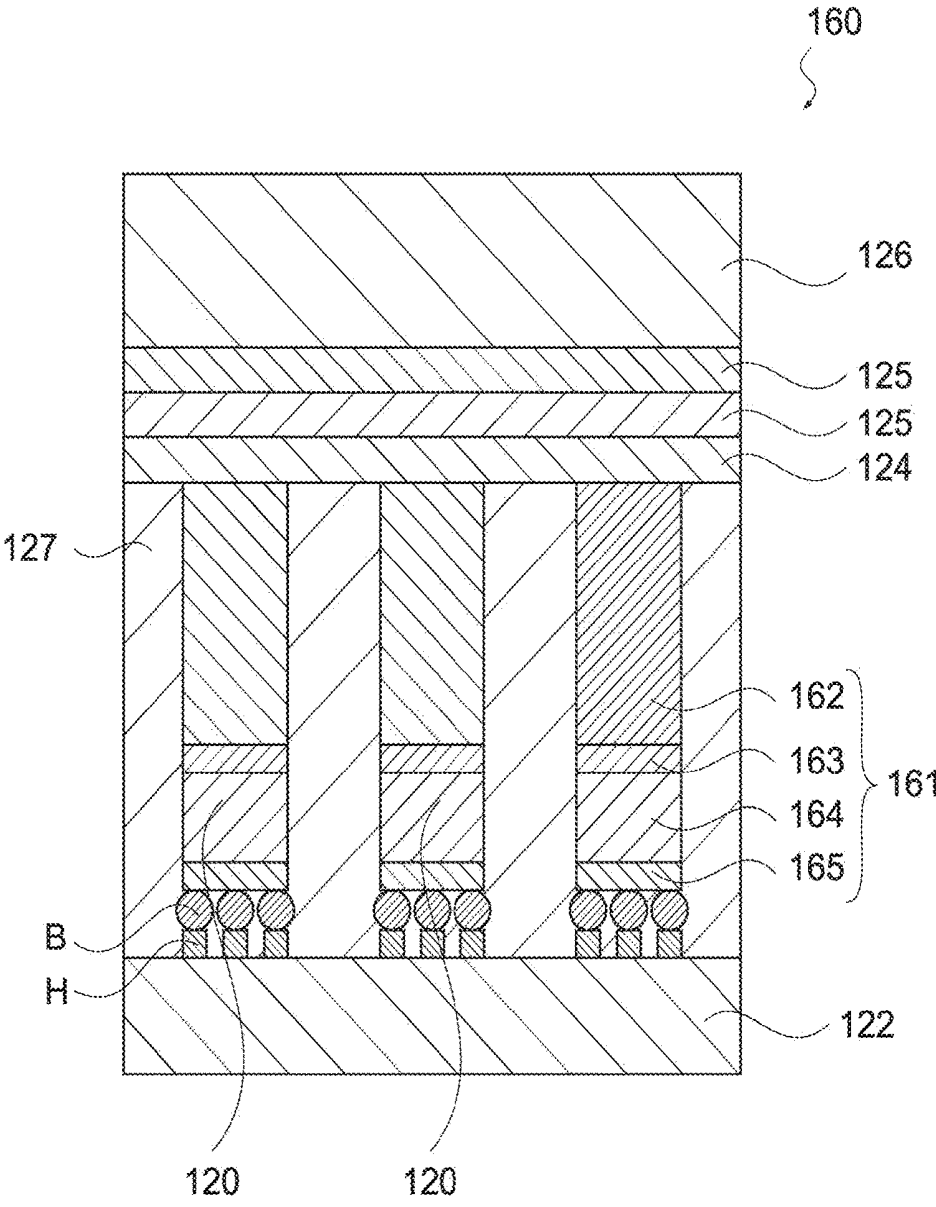

FIG.17

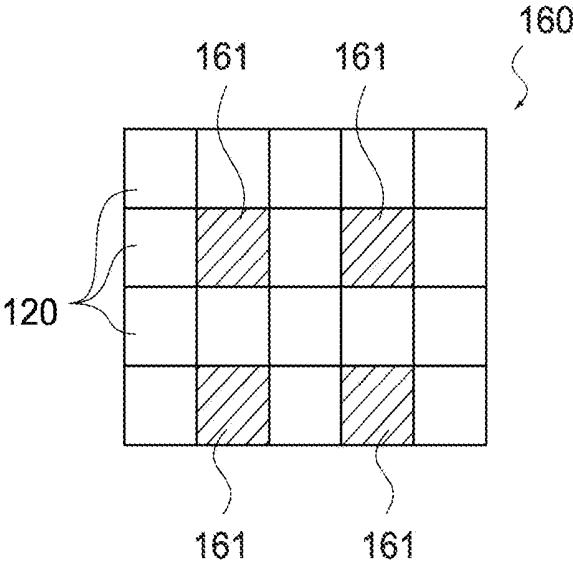

FIG.18

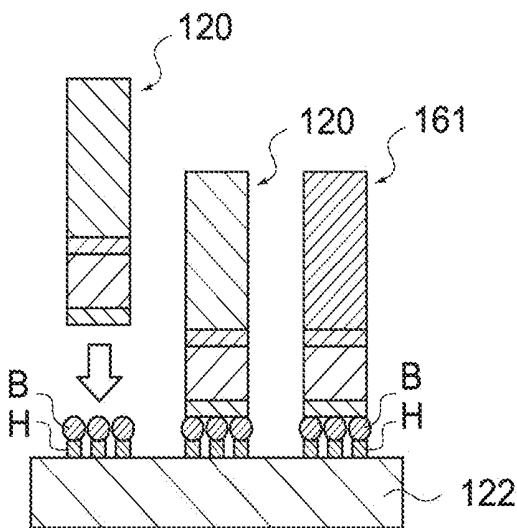

FIG.19

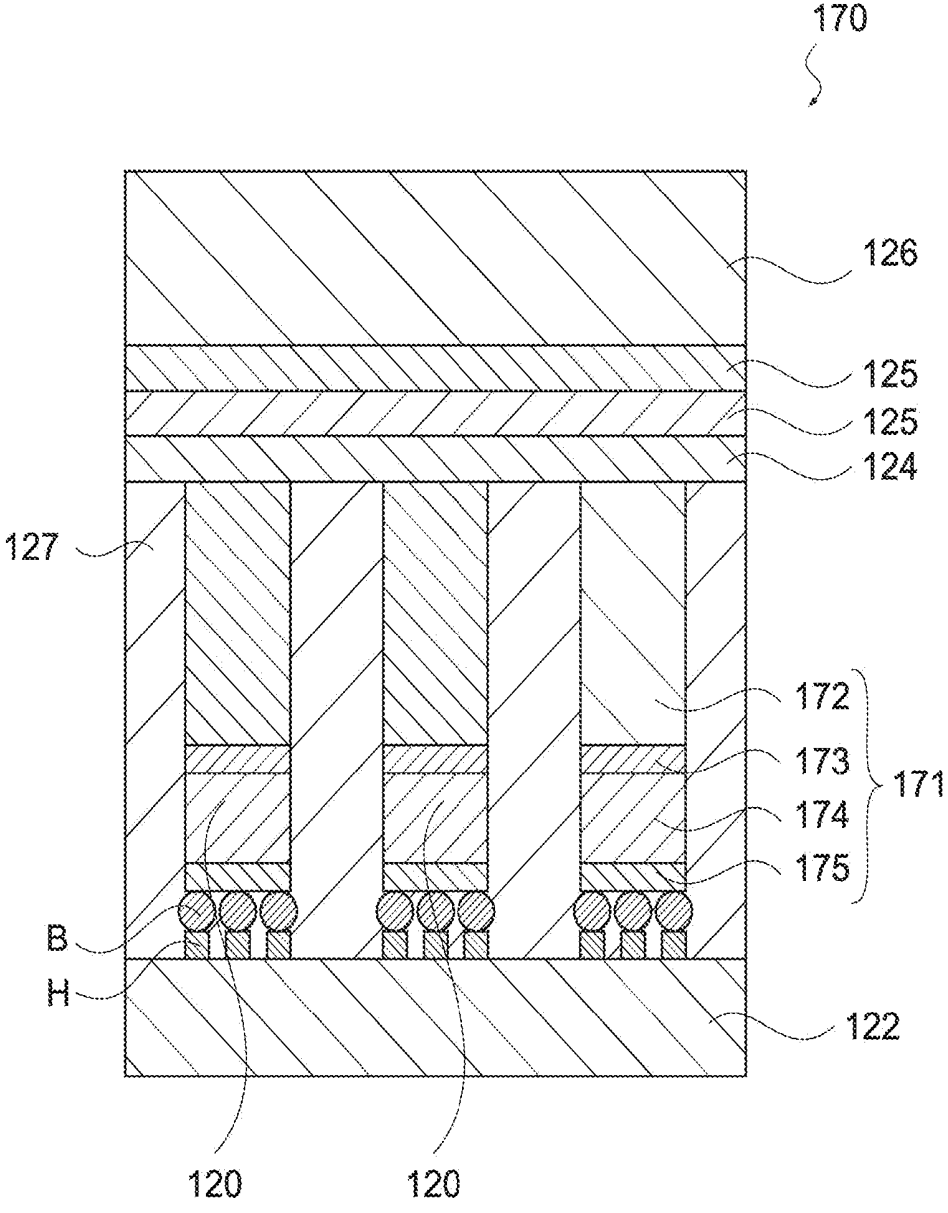

FIG.20

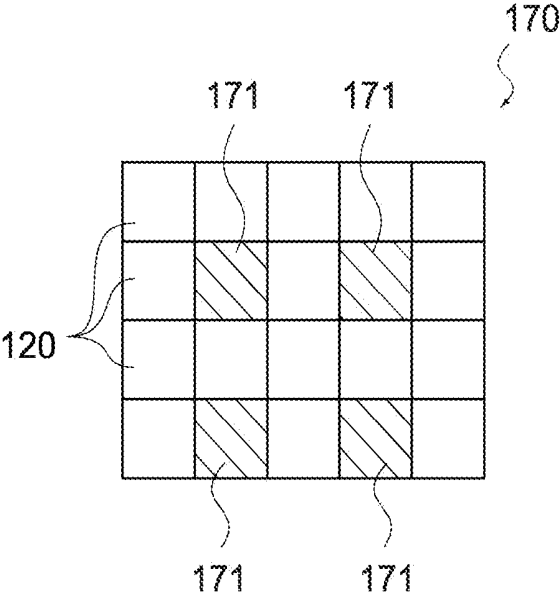

FIG. 21

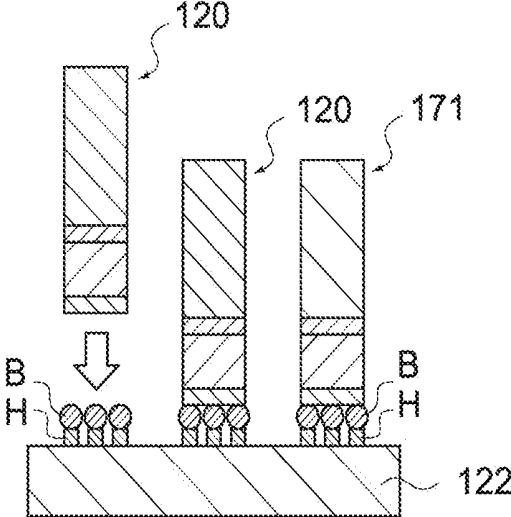

FIG. 22

**ULTRASONIC ARRAY OSCILLATOR,
METHOD OF PRODUCING ULTRASONIC
ARRAY OSCILLATOR, ULTRASONIC
PROBE, AND ULTRASONIC DIAGNOSTIC
APPARATUS**

TECHNICAL FIELD

[0001] The present technology relates to an ultrasonic array oscillator usable for ultrasonic imaging, a method of producing an ultrasonic array oscillator, an ultrasonic probe, and an ultrasonic diagnostic apparatus.

BACKGROUND ART

[0002] An ultrasonic diagnostic apparatus widely used in a medical field and the like generates an ultrasonic image of an object to be diagnosed by irradiating the object to be diagnosed with ultrasonic waves by an ultrasonic probe and by detecting the reflected waves by the ultrasonic probe. The ultrasonic probe includes an array oscillator where a plurality of ultrasonic oscillators are arranged, and can control a convergent point of the ultrasonic waves by adjusting a delay time of driving signals input to the respective ultrasonic oscillators and detection signals output from the respective ultrasonic oscillators.

[0003] Examples of the array oscillator include a 1D array including ultrasonic oscillators arranged linearly and a 2D array including oscillators arranged on a plane. In order to improve a resolution and an imaging speed, a larger number of ultrasonic oscillators are mounted on one array oscillator. Meanwhile, ultrasonic catheters and the like inserted into blood vessels or the like are widely used. It is desirable to downsize the ultrasonic probes. Accordingly, it is desirable to densely mount the ultrasonic oscillators. Individual ultrasonic oscillators have smaller mounting areas.

[0004] Meanwhile, where the ultrasonic oscillators have the smaller mounting areas, impedance is mismatched and a detection sensitivity of the ultrasonic waves may be degraded. As a countermeasure, an amplifier is used to match the impedance. In general, an ASIC (application specific integrated circuit) is used (for example, see Patent Literature 1).

CITATION LIST

Patent Literature

[0005] Patent Literature 1: Japanese Patent Application Laid-open No. 2006-166985

DISCLOSURE OF INVENTION

Technical Problem

[0006] However, the ASIC needs a certain size. If the ASIC is mounted on each oscillator, it is difficult to secure a space to be mounted. The ASIC can be mounted apart from the oscillator. If a wiring line connecting the ASIC and the oscillator is long, the impedance matching is less effective. Moreover, the ASIC needs to be designed depending on the structure of the array oscillator and it is thus difficult to decrease production costs.

[0007] The present technology is made in view of the above-mentioned circumstances, and it is an object of the present technology to provide an ultrasonic array oscillator, a method of producing an ultrasonic array oscillator, an

ultrasonic probe, and an ultrasonic diagnostic apparatus having a high impedance matching effect and excellent productivity.

Solution to Problem

[0008] In order to achieve the object, an ultrasonic array oscillator according to an embodiment of the present technology includes ultrasonic oscillators and semiconductor chips. The ultrasonic oscillators form an array. The semiconductor chips are bonded to the respective ultrasonic oscillators that form impedance matching circuits.

[0009] With this configuration, each ultrasonic oscillator and each impedance matching circuit are formed integrally, a wiring line length between the both may be short. A high impedance matching effect can be provided, an SNR (signal-noise ratio) can be improved, and the contrast of the ultrasonic image can be improved. In addition, when modules (hereinafter referred to as oscillator module) where each ultrasonic oscillator and each impedance matching circuit are formed integrally is mounted to a substrate, the modules are arranged with a high degree of freedom. Arraying and arranging the ultrasonic oscillators having different frequencies are easily optimized. Further, the oscillator modules having specific structures can be arrayed in any shapes and can correspond to a variety of apparatuses. It is possible to reuse the oscillator modules in various apparatuses. In a case where the ultrasonic oscillator has a footprint greater than that of a semiconductor chip, the same semiconductor chip can be used for any ultrasonic oscillators having any sizes.

[0010] Each of the impedance matching circuits may include an amplifier and a TR (transmit-receive) switch.

[0011] Drive signals for generating the ultrasonic waves and detection signals generated by the detection of the ultrasonic waves flow to the ultrasonic oscillators. The drive signals have signal strengths greatly different from those of the detection signals. With this configuration, only the detection signals can be amplified by switching signal paths by the TR switches and impedance matching circuits can be formed.

[0012] Each of the semiconductor chips may include a first semiconductor chip including the amplifier and a second semiconductor chip including the TR switch.

[0013] By forming the impedance matching circuits with a plurality of semiconductor chips, the size of the semiconductor chip can be reduced and it is possible to mount the impedance matching circuits to the ultrasonic oscillators having small sizes.

[0014] Each of the semiconductor chips may be an SOI (Silicon on Insulator) chip.

[0015] The SOI chip has advantages of a small size, a less leakage current, and the like, and is suitable as the semiconductor chip bonded to the ultrasonic oscillators.

[0016] The ultrasonic oscillators may include first ultrasonic oscillators each having a first frequency as a center frequency of oscillation and second ultrasonic oscillators each having a second frequency different from the first frequency as a center frequency of oscillation.

[0017] The oscillation frequencies of the ultrasonic oscillators depend on the thickness of the piezoelectric layer. By forming integrally the ultrasonic oscillators and the impedance matching circuits, the ultrasonic oscillators having greatly different oscillation frequencies can be arranged with a high degree of freedom.

[0018] The ultrasonic array oscillators may further include MEMS (Micro Electro Mechanical Systems). The MEMS and the ultrasonic oscillators form the array.

[0019] By arraying the ultrasonic oscillators and the MEMS, the ultrasonic waves can be generated by using the ultrasonic oscillators having great ultrasonic strength, and the reflected waves can be detected by using the MEMS module having high sensitivity. Thus, it is possible to improve a detection sensitivity.

[0020] The ultrasonic array oscillator may further includes optical devices, the optical devices and the ultrasonic oscillators forming the array.

[0021] By arraying the ultrasonic oscillators and the optical devices, it is possible to perform light ultrasonic imaging with a single ultrasonic probe. The ultrasonic imaging detects the ultrasonic waves generated by the light irradiated from the optical devices.

[0022] In order to achieve the object, a method of producing an ultrasonic array oscillator according to an embodiment of the present technology includes mounting ultrasonic oscillators, to which semiconductor chips that form impedance matching circuits are bonded, by using a pick-and-place method.

[0023] The ultrasonic oscillators may include first ultrasonic oscillators each having a first frequency as a center frequency of oscillation and second ultrasonic oscillators each having a second frequency different from the first frequency as a center frequency of oscillation.

[0024] In the method of producing the ultrasonic array oscillator, the mounting step includes mounting the ultrasonic oscillators and the MEMS by using the pick-and-place method.

[0025] In the method of producing the ultrasonic array oscillator, the mounting step includes mounting the ultrasonic oscillators and optical devices by using the pick-and-place method.

[0026] In order to achieve the object, an ultrasonic probe according to an embodiment of the present technology includes an ultrasonic array oscillator.

[0027] The ultrasonic array oscillator includes ultrasonic oscillators that form an array, and semiconductor chips bonded to respective of the ultrasonic oscillators that form impedance matching circuits.

[0028] In order to achieve the object, an ultrasonic diagnostic apparatus according to an embodiment of the present technology includes an ultrasonic probe and a main body.

[0029] The ultrasonic probe includes an ultrasonic array oscillator, the ultrasonic array oscillator including ultrasonic oscillators that form an array, and semiconductor chips bonded to respective of the ultrasonic oscillators that form impedance matching circuits

[0030] The main body to which the ultrasonic probe is connected, the main body supplying the ultrasonic array oscillator with a drive signal and generating an ultrasonic image on the basis of a detection signal output from the ultrasonic array oscillator.

Advantageous Effects of Invention

[0031] As described above, the present technology can provide an ultrasonic array oscillator, a method of producing an ultrasonic array oscillator, an ultrasonic probe, and an ultrasonic diagnostic apparatus having a high impedance matching effect and excellent productivity. It should be

noted that the effects described here are not necessarily limitative and may be any of effects described in the present disclosure.

BRIEF DESCRIPTION OF DRAWINGS

[0032] FIG. 1 is a schematic view showing a configuration of an ultrasonic diagnostic apparatus according to this embodiment.

[0033] FIG. 2 is a cross-sectional view showing the structure of an ultrasonic array oscillator included in the ultrasonic diagnostic apparatus.

[0034] FIG. 3 is a perspective view showing the oscillator modules included in the ultrasonic array oscillator.

[0035] FIG. 4 is a schematic view showing a circuit configuration of the oscillator modules included in the ultrasonic array oscillator.

[0036] FIG. 5 is a schematic view showing a method of producing the ultrasonic array oscillator.

[0037] FIG. 6 is a schematic view showing a method of producing the ultrasonic array oscillator.

[0038] FIG. 7 is a schematic view showing a method of producing the ultrasonic array oscillator.

[0039] FIG. 8 is a schematic view showing a method of producing the ultrasonic array oscillator.

[0040] FIG. 9 is a schematic view showing a method of producing the ultrasonic array oscillator.

[0041] FIG. 10 is a schematic view showing an arrangement of the oscillator modules included in the ultrasonic array oscillator.

[0042] FIG. 11 is a schematic view showing a convex type ultrasonic probe of the oscillator modules included in the ultrasonic array oscillator.

[0043] FIG. 12 is a schematic view showing a Hanafy lens type ultrasonic probe of the oscillator modules included in the ultrasonic array oscillator.

[0044] FIG. 13 is a schematic view showing a 1D arrangement array of the oscillator modules included in the ultrasonic array oscillator.

[0045] FIG. 14 is a schematic view showing circuit configurations of the oscillator modules included in the ultrasonic array oscillator.

[0046] FIG. 15 is a schematic view showing an IVUS of an ultrasonic array oscillator in a comparative embodiment.

[0047] FIG. 16 is a schematic view showing an IVUS of the ultrasonic array oscillator according to an embodiment of the present technology.

[0048] FIG. 17 is a cross-sectional view showing the ultrasonic array oscillator including the oscillator modules and the MEMS modules according to an embodiment of the present technology.

[0049] FIG. 18 is a schematic view showing an arrangement of the ultrasonic array oscillator.

[0050] FIG. 19 is a schematic view showing a method of producing the ultrasonic array oscillator.

[0051] FIG. 20 is a cross-sectional view showing the ultrasonic array oscillator including the oscillator modules and optical device modules according to an embodiment of the present technology.

[0052] FIG. 21 is a schematic view showing an arrangement of the ultrasonic array oscillator.

[0053] FIG. 22 is a schematic view showing a method of producing the ultrasonic array oscillator.

MODE(S) FOR CARRYING OUT THE
INVENTION

[0054] [Configuration of Ultrasonic Diagnostic Apparatus]

[0055] FIG. 1 is a schematic view showing a configuration of an ultrasonic diagnostic apparatus 1 according to this embodiment. As shown in FIG. 1, the ultrasonic diagnostic apparatus 1 includes a main body 11, an ultrasonic probe 12, and a cable 15. The main body 11 is connected to the ultrasonic probe 12 via the cable 15.

[0056] The main body 11 supplies the ultrasonic probe 12 with drive signals via the cable 15, generates an ultrasonic image on the basis of ultrasonic wave detection signals output from the ultrasonic probe 12, and displays the ultrasonic image on the display.

[0057] The ultrasonic probe 12 includes an array oscillator 121, comes in contact with an object to be diagnosed, emits an ultrasonic wave, and detects reflected waves. The ultrasonic probe 12 is supplied with the drive signals from the main body 11 via the cable 15, and outputs the detection signals to the main body 11.

[0058] Types of the ultrasonic probe 12 are not especially limited. Any type of the ultrasonic probe, e.g., a linear type, sector type, convex type, or radial type ultrasonic probe, may be used. A two-dimensional array type ultrasonic probe may be used. Alternatively, the ultrasonic probe 12 may be an ultrasonic catheter that can be inserted into blood vessels and the like.

[0059] [Configuration of Array Oscillator]

[0060] FIG. 2 is a cross-sectional view showing the structure of the array oscillator 121. As shown in FIG. 2, the array oscillator 121 includes a substrate 122, an oscillator layer 123, an upper electrode layer 124, acoustic matching layers 125, and an acoustic lens 126. They are laminated in an order of the substrate 122, the oscillator layer 123, the upper electrode layer 124, the acoustic matching layers 125, and the acoustic lens 126.

[0061] The substrate 122 is a rigid print substrate, an FPC (flexible printed circuits) substrate, or the like. Wiring lines H and bumps B are formed on the mounting surface. The wiring lines H are connected to the main body 11 via the cable 15.

[0062] The oscillator layer 123 includes a plurality of oscillator modules 120 and a filler 127. Each of the plurality of oscillator modules 120 is mounted to the substrate 122 via the bumps B. The filler 127 is filled between the respective oscillator modules 120. The filler 127 may be acrylic resin, polyurethane resin, or an acoustic absorber. The oscillator modules 120 will be described later in detail.

[0063] Note that while only three oscillator modules 120 are shown in FIG. 2, the array oscillator 121 in fact includes a larger number of (from about several hundreds to about several thousands) oscillator modules 120.

[0064] The upper electrode layer 124 functions as an electrode of piezoelectric layers 131 as described later. The upper electrode layer 124 is formed of an electric conductive material, e.g., metal plating. Note that the upper electrode layer 124 may be formed over the plurality of oscillator modules 120 as shown in FIG. 2, or may be separated for each of the oscillator modules 120.

[0065] The acoustic matching layers 125 decrease an acoustic impedance difference between the object to be diagnosed and the ultrasonic oscillators 130, and prevents ultrasonic waves from reflecting toward the object to be

diagnosed. The acoustic matching layers 125 are formed of synthetic resin or a ceramics material. The number of the acoustic matching layers 125 may be two as shown in FIG. 2. Alternatively, one acoustic matching layer or three or more acoustic matching layers may be used.

[0066] The acoustic lens 126 converges the ultrasonic waves generated by the oscillator layer 123. The acoustic lens 126 is positioned at a tip of the ultrasonic probe 12 as shown in FIG. 1, and comes in contact with the object to be diagnosed.

[0067] The acoustic lens 126 is formed of silicone rubber or the like, and its size and shape are not especially limited.

[0068] [Configuration of Oscillator Module]

[0069] FIG. 3 is a schematic view showing the oscillator modules 120. As shown in FIG. 3, each oscillator module 120 includes an ultrasonic oscillator 130 and a circuit chip 140. A power supply wiring line 151, a signal wiring line 152, and a ground wiring line 153 are connected to each oscillator module 120.

[0070] Each ultrasonic oscillator 130 includes a piezoelectric layer 131, a lower electrode layer 132, and a backing layer 133. These are laminated in an order of the backing layer 133, the lower electrode layer 132, and the piezoelectric layer 131.

[0071] The piezoelectric layer 131 is formed of a piezoelectric material such as PZT (lead zirconate titanate). When a voltage is applied between the lower electrode layer 132 and the upper electrode layer 124 (see FIG. 2), the piezoelectric layer 131 generates vibration due to an inverse piezoelectric effect, and generates the ultrasonic waves. In addition, when the reflected waves from the object to be diagnosed enter the piezoelectric layer 131, polarization is generated due to a piezoelectric effect. The size of the piezoelectric layer 131 is not especially limited, but may be 250 μm square, for example.

[0072] The lower electrode layer 132 functions as an electrode of the piezoelectric layer 131. The lower electrode layer 132 is formed of an electric conductive material, e.g., metal plating.

[0073] The backing layer 133 is laminated on the circuit chip 140, and absorbs unnecessary vibration of the ultrasonic oscillator 130. The backing layer 133 is formed of a material such as a mixture of a filler and synthetic resin.

[0074] The circuit chip 140 is bonded to each ultrasonic oscillator 130, and forms an impedance matching circuit of the ultrasonic oscillator 130. The circuit chip 140 is a semiconductor chip formed of a semiconductor material. Specifically, the circuit chip 140 can be an SOI chip produced by an SOI (Silicon on Insulator) process. More specifically, the circuit chip 140 can be a BGD-SOI chip produced by a BCD-SOI (bipolar CMOS DMOS) process.

[0075] Each circuit chip 140 may be bonded to each ultrasonic oscillator 130, and may not necessarily be arranged between the backing layer 133 and the substrate 122. Also, the circuit chips 140 may not be bonded to all the ultrasonic oscillators 130, and may be bonded only some of the ultrasonic oscillators 130. The size of the circuit chip 140 can be the same as or smaller than the size of the bottom surface of the ultrasonic oscillator 130.

[0076] FIG. 4 is a schematic view showing a circuit configuration of the circuit chip 140. As shown in FIG. 4, the circuit chip 140 includes a first TR (transmit-receive) switch 141, an amplifier 142, and a second TR switch 143.

[0077] The power supply wiring line 151 is connected to the amplifier 142. The signal wiring line 152 is connected to the upper electrode layer 124, and is separated into a signal wiring line 152A not via the amplifier 142 and a signal wiring line 152B via the amplifier 142. The ground wiring line 153 is connected to the lower electrode layer 132.

[0078] The first TR switch 141 is connected to the signal wiring line 152, and switches a signal path between the signal wiring line 152A and the signal wiring line 152B. The first TR switch 141 can be a transistor or a diode.

[0079] The amplifier 142 is connected to the signal wiring line 152B, and amplifies signals flowing through the signal wiring line 152B by utilizing electric power supplied from the power supply wiring line 151. The amplifier 142 can be a diode.

[0080] The second TR switch 143 is connected to the signal wiring line 152, and switches a signal path between the signal wiring line 152A and the signal wiring line 152B. The second TR switch 143 can be a transistor or a diode.

[0081] The oscillator module 120 has the above-described configuration. As described above, since each oscillator module 120 includes the circuit chip 140 that forms an impedance matching circuit, a wiring line length between the ultrasonic oscillator and the impedance matching circuit is short, and an impedance matching is effectively performed. This allows an SNR (signal-noise ratio) to be improved, and the contrast of the ultrasonic image to be increased.

[0082] [Operation of Ultrasonic Diagnostic Apparatus]

[0083] An operation of the ultrasonic diagnostic apparatus 1 will be described. When the ultrasonic diagnostic apparatus 1 is turned on, the ultrasonic probe 12 is supplied with electric power from the main body 11 via the cable 15 (see FIG. 1). The electric power flows to the power supply wiring line 151 via the substrate 122 and is supplied to the amplifier 142 (see FIG. 4).

[0084] When the ultrasonic probe 12 comes in contact with the object to be diagnosed and an instruction to start diagnosis is input, the main body 11 generates the drive signals. The drive signals are supplied to the ultrasonic probe 12 via the cable 15, and flow to the signal wiring line 152 via the substrate 122. In this case, the first TR switch 141 and the second TR switch 143 are switched to a signal wiring line 152A side, and the drive signals are supplied to the upper electrode layer 124 via the second TR switch 143 and the first TR switch 141.

[0085] Due to a potential difference between the upper electrode layer 124 and the lower electrode layer 132, the piezoelectric layer 131 generates vibration due to an inverse piezoelectric effect, and generates the ultrasonic waves. The generated ultrasonic waves enter the object to be diagnosed via the acoustic matching layer 125 and the acoustic lens 126.

[0086] The reflected waves generated in the object to be diagnosed enter the piezoelectric layer 131 via the acoustic lens 126 and the acoustic matching layer 125. The piezoelectric layer 131 is polarized due to the piezoelectric effect, and a current (hereinafter referred to as detection signals) flows through the signal wiring line 152. In this case, the first TR switch 141 and the second TR switch 143 are switched to a signal wiring line 152B side, and the detection signals are amplified by the amplifier 142. The amplified detection signals flow from the first TR switch 141 to the signal wiring

line 152 and are transmitted to the main body 11 via the substrate 122 and the cable 15.

[0087] The main body 11 generates the ultrasonic image on the basis of the detection signals. As described above, the drive signals are transmitted to the upper electrode layer 124 not via the amplifier 142, but the detection signals are amplified by the amplifier 142 and are transmitted to the main body 11. The route switching of the drive signal and the detection signal is performed by the first TR switch 141 and the second TR switch 143. Thus, the impedances between the drive signals having a great signal strength and the detection signal having a small signal strength can be matched.

[0088] [Method of Producing Array Oscillator]

[0089] FIG. 5 to FIG. 8 are schematic views showing a method of producing the array oscillator 121. As shown in FIG. 5(a), the circuit chips 140 are arranged on a sacrifice substrate K. The circuit chips 140 can be adhered to the sacrifice substrate K with an adhesive that is peeled by UV (ultraviolet) irradiation.

[0090] Next, as shown in FIG. 5(b), the backing layer 133 is laminated on the sacrifice substrate K and the circuit chips 140. Next, as shown in FIG. 5(c), parts of the backing layer 133 are removed to expose the circuit chips 140. Openings 133a are formed by the removal.

[0091] Next, as shown in FIG. 6(a), a conductive material D1 is arranged in the openings 133a and over the backing layer 133. The conductive material D1 includes metal such as copper, for example. Next, as shown in FIG. 6(b), a conductive material D2 is arranged on the conductive material D1. The conductive material D2 can be a conductive adhesive. The conductive material D1 and the conductive material D2 form the lower electrode layer 132.

[0092] Next, as shown in FIG. 6(c), the piezoelectric layer 131 is arranged on the conductive material D2 and adhered by the conductive material D2. Next, as shown in FIG. 7(a), the piezoelectric layer 131 and the backing layer 133 are cut by dicing to separate into individual oscillator modules 120.

[0093] Next, the oscillator modules 120 are separated from the sacrifice substrate K. By ultraviolet irradiation, the adhesive between the circuit chip 140 and the sacrifice substrate K can be peeled. FIG. 7(b) is a schematic view showing the oscillator modules 120 separated from the sacrifice substrate K.

[0094] Next, as shown in FIG. 7(c), the oscillator module 120 is mounted to the substrate 122. As shown in FIG. 7(c), the wiring lines H and the bumps B are formed on the substrate 122. Note that the wiring lines H are the power supply wiring line 151, the signal wiring line 152, and the ground wiring line 153. The oscillator module 120 can be mounted to the substrate 122 by connecting the circuit chip 140 to the wiring lines H via the bumps B.

[0095] Next, as shown in FIG. 8(a), other oscillator modules 120 are mounted to the substrate 122, respectively. Note that a method of mounting objects to be mounted separately in this way is called as a pick-and-place method.

[0096] Next, as shown in FIG. 8(b), the filler 127 is filled between the respective oscillator modules 120 to form the oscillator layer 123. Next, as shown in FIG. 8(c), the upper electrode layer 124 and the acoustic matching layer 125 are laminated on the oscillator layer 123.

[0097] Next, the acoustic lens 126 is laminated on the acoustic matching layer 125 (see FIG. 2). In the above-described manner, the array oscillator 121 can be produced.

As described above, in the array oscillator **121** according to this embodiment, since each ultrasonic oscillator **130** and each circuit chip **140** are formed integrally, the pick-and-place method can be used for mounting.

[0098] Here, the array oscillator used for the ultrasonic diagnostic apparatus includes about several thousands of ultrasonic oscillators. In particular, a medical ultrasonic probe has a different configuration depending on each diagnosis item. Even if the pick-and-place method is used, the costs are not high.

[0099] In addition, in the related art, it is necessary to produce array oscillators separately for a variety of ultrasonic probes including array oscillators having different shapes. In contrast, according to this embodiment, the oscillator modules **120** can be freely arranged by the pick-and-place method. Thus, it is possible to use the oscillator modules **120** having the same structure in a variety of the ultrasonic probes.

[0100] Note that the method of producing the array oscillator **121** is not limited to the above-described method. FIG. **9** is a schematic view showing another method of producing the array oscillator **121**. As shown in FIG. **5(a)**, the circuit chips **140** are arranged on the sacrifice substrate **K**. Thereafter, as shown in FIG. **9(a)**, the backing layer **133** is formed in a thickness similar to the thickness of the circuit chips **140**.

[0101] Further, as shown in FIG. **9(b)**, a structure, in which the backing layer **133**, the conductive material **D1**, and the conductive material **D2** are laminated, is produced. By laminating the laminate on the structure of FIG. **9(a)**, the structure of FIG. **6(b)** can be produced. The array oscillator **121** can be produced by the method similar to the above-described method after that.

[0102] [Arrangement of Oscillator Modules]

[0103] As described above, the ultrasonic probe **12** according to this embodiment includes the oscillator modules **120** each having the ultrasonic oscillator **130** and the circuit chip **140**, and the oscillator modules **120** can be mounted to the substrate **122** one by one. Accordingly, oscillator modules **120** can be arranged with a high degree of freedom.

[0104] FIG. **10** is a schematic view showing an arrangement of the oscillator modules **120**, which are viewed from the direction perpendicular to the substrate **122** (see FIG. **2**). As shown in FIG. **10**, the oscillator modules **120** can have a honeycomb 2D arrangement. The honeycomb 2D arrangement refers to a regular hexagon provided by lines connecting the centers of the oscillator modules **120** viewed from the direction perpendicular to the substrate **122**.

[0105] In general, it is desirable for an ultrasonic probe to decrease a side lobe (ultrasonic waves emitted in the directions deviated from the center direction which is directed by the ultrasonic waves). The honeycomb 2D arrangement can widen the spaces between the adjacent ultrasonic oscillators **130**, and can suppress the side lobe.

[0106] In particular, by the Dice and Fill method used for the production of the array oscillator in the related art, large electrodes in a honeycomb 2D arrangement are arranged on piezoelectric devices diced small in a lattice. This method results in a substantial degraded device pitch width. In contrast, in the array oscillator **121** according to this embodiment, it is possible to arrange the ultrasonic oscillators **130** at minimum device processing pitches by the pick-and-place method.

[0107] FIG. **11** is a schematic view showing a convex type ultrasonic probe including the oscillator modules **120** according to this embodiment. As shown in FIG. **11**, it is necessary to arrange the oscillator modules **120** on a curved surface in the convex type ultrasonic probe. However, the impedance matching circuits in the related-art structure are provided by the ASICs, it is difficult to arrange the ASICs on the curved surface.

[0108] In contrast, the array oscillator **121** according to this embodiment includes the oscillator modules **120** each including the ultrasonic oscillator **130** and the circuit chip **140** integrally formed. As shown in FIG. **11**, the oscillator modules **120** can be densely mounted. Thus, it is possible to improve a contrast of the ultrasonic image and a slice resolution (resolution in a depth direction of the object to be diagnosed).

[0109] FIG. **12** is a schematic view showing a Hanafy lens type ultrasonic probe including the oscillator modules **120** according to this embodiment. The Hanafy lens uses two or more types of ultrasonic oscillators as the array oscillator in order to improve the slice resolution.

[0110] As shown in FIG. **12**, the array oscillator **121** includes oscillator modules **120L** each including an ultrasonic oscillator **130L** having a low center frequency of oscillation (large opening size) and an oscillator modules **120H** each including ultrasonic oscillator **130H** each having a high center frequency of oscillation (small opening size). Note that as the frequency of each ultrasonic oscillator **130** is determined by the thickness of each piezoelectric layer **131**, the thickness of the piezoelectric layer **131** of each ultrasonic oscillator **130L** is different from the thickness of the piezoelectric layer **131** of each ultrasonic oscillator **130**.

[0111] The Hanafy lens allows an ultrasonic beam diameter to be uniform in the depth direction by changing focal points of the ultrasonic waves at an inner periphery side and at an outer periphery side. As described above, since the frequency of each ultrasonic oscillators is determined by the thickness of the piezoelectric layer, the array oscillator has been produced in the related art by curving that the piezoelectric layer is machined to have a curved surface and dicing that the piezoelectric layer is divided. In contrast, according to this embodiment, the ultrasonic oscillators **130** including the piezoelectric layers **131** with different thicknesses are produced in advance, and can be mounted separately by using the pick-and-place method.

[0112] Thus, it is possible to produce the array oscillator **121** including the ultrasonic oscillators **130L** and the ultrasonic oscillators **130H** with a greater frequency difference therebetween as compared with an array oscillator produced by the curving. Also, it is possible to freely decide the arrangement of the ultrasonic oscillators **130L** and the ultrasonic oscillators **130H**. Furthermore, the Hanafy lens can have the honeycomb 2D arrangement, and the side lobe can be decreased.

[0113] [Arrangement and Number of Circuit Chips]

[0114] As described above, each oscillator module **120** of the array oscillator **121** includes the ultrasonic oscillator **130** and the circuit chip **140**. Here, not one circuit chip **140** but a plurality of the circuit chips **140** may be used.

[0115] FIG. **13** is a schematic view showing the array oscillator **121** including the oscillator modules **120** having a plurality of circuit chips. As shown in FIG. **13**, the array oscillator **121** can be a narrow chip 1D arrangement array including narrow ultrasonic oscillators **130** arranged in one

direction. The circuit chips **140** can include three circuit chips, i.e., the circuit chip **140A**, the circuit chip **140B**, and circuit chip **140C**.

[0116] FIG. **14** is a schematic view showing circuit configurations of the circuit chips **140A** to **C**. As shown in FIG. **14**, the circuit chip **140A** includes the second TR switch **143**, the circuit chip **140B** includes the amplifier **142**, and the circuit chip **140C** includes the first TR switch **141**, respectively. The first TR switch **141**, the amplifier **142**, and the second TR switch **143** operate as described above. The circuit chips **140A** to **C** may be produced by dicing and cutting the circuit chips **140**, or may be separately produced.

[0117] When the circuit chip **140** is divided into devices of the impedance matching circuit, the circuit chips **140** can be downsized. Even if the widths of the ultrasonic oscillators **130** are narrow like the narrow pith 1D arrangement array, it is possible to bond the circuit chips **140** to the ultrasonic oscillators **130**. Note that the circuit chip **140** may include two circuit chips. For example, one circuit chip has the amplifier **142** and the other circuit chip has the first TR switch **141** and the second TR switch **143**.

[0118] [Application to IVUS]

[0119] An IVUS (intravascular ultrasonic endoscope) is one type of the ultrasonic probes, and is used for observation of vascular walls of coronary blood vessels. The IVUS includes an array oscillator having a plurality of ultrasonic oscillators arranged circumferentially and an amplifier that amplifies detection signals output from respective ultrasonic oscillators.

[0120] FIG. **15** is a schematic view showing an IVUS **300** having the related-art structure. As shown in FIG. **15**, the IVUS **300** includes a catheter **301**, an array oscillator **302**, a signal processing chip **303**, and a wiring line **304**. Vascular walls are irradiated with the ultrasonic waves generated in the array oscillator **302** via the catheter **301** that is inserted into blood vessels, and the reflected waves enter into the array oscillator **302** via the catheter **301** and are detected. The detection signals are amplified by the signal processing chip **303** and are transmitted to a main body via the wiring line **304**.

[0121] Thus, in the IVUS **300**, the signal processing chip **303** is necessary to arrange separately from the array oscillator **302**. The signal processing chip **303** inhibits bending of the IVUS **300**, which makes the operation of the catheter **301** difficult.

[0122] FIG. **16** is a schematic view showing an IVUS **400** using the array oscillator **121** according to this embodiment. As shown in FIG. **16**, the IVUS **400** includes a catheter **401**, the array oscillator **121**, and a wiring line **402**. Vascular walls are irradiated with the ultrasonic waves generated by the array oscillator **121** via the catheter **401** that is inserted into blood vessels, and the reflected waves enter into the array oscillator **121** via the catheter **401** and are detected. The detection signals are amplified by the signal processing chips **140** included in the array oscillator **121** and are transmitted to a main body via the wiring line **402**.

[0123] Since the array oscillator **121** includes the circuit chips **140**, in the IVUS **400**, there is no need to provide the signal processing chip in addition to the array oscillator **121**. Thus, no signal processing chip inhibits bending of the IVUS **400**, which makes the operation of the catheter **401** easy. Note that the IVUS **400** may include another signal processing chip unrelated to the impedance matching cir-

cuits. Even in this case, as no impedance matching circuits are necessary, it is possible to decrease the size of the signal processing chip.

[0124] [Co-mounting of Ultrasonic Oscillators and MEMS]

[0125] The oscillator module **120** according to this embodiment and MEMS modules including MEMS (Micro Electro Mechanical Systems) can be co-mounted.

[0126] FIG. **17** is a schematic view showing an array oscillator **160** including oscillator modules and the MEMS modules co-mounted. As shown in FIG. **17**, the array oscillator **160** includes the oscillator modules **120** and the MEMS modules **161**. Other configurations of the array oscillator **160** are the same as those of the array oscillator **121**.

[0127] Each MEMS module **161** includes an MEMS **162**, a lower electrode layer **163**, a backing layer **164**, and a circuit chip **165**. The MEMS **162** is an ultrasonic sensor formed by the MEMS. Specific configuration of the MEMS is not especially limited. The configurations of the lower electrode layer **163**, the backing layer **164**, and the circuit chip **165** are similar to those of the oscillator module **120**. Note that the configuration of the MEMS module **161** is not limited to this, and may at least include MEMS **162**.

[0128] FIG. **18** is a schematic view showing an arrangement of the oscillator modules **120** and the MEMS modules **161** of the array oscillator **160**, and is viewed from the direction perpendicular to the substrate **122**. As shown in FIG. **18**, the oscillator modules **120** and the MEMS modules **161** are co-mounted on the substrate **122** to form the array. Note that the arrangement of the oscillator modules **120** and the MEMS modules **161** is not limited to that shown in FIG. **18**.

[0129] With this configuration, the ultrasonic waves can be generated by using the oscillator modules **120** having great ultrasonic strength, and the reflected waves can be detected by using the MEMS modules **161** having high sensitivity. Thus, it is possible to improve an ultrasonic wave detection sensitivity.

[0130] FIG. **19** is a schematic view showing a method of producing the array oscillator **160**. As shown in FIG. **19**, both of the oscillator modules **120** and the MEMS modules **161** can be mounted to the substrate **122** by using the pick-and-place method. After both the modules are mounted to the substrate **122**, the filler **127**, the upper electrode layer **124**, the acoustic matching layer **125**, and the acoustic lens **126** are formed. As a result, it is possible to produce the array oscillator **160** shown in FIG. **17**, similar to the array oscillator **121**.

[0131] [Co-mounting of Ultrasonic Oscillators and Optical Devices]

[0132] The oscillator modules **120** according to this embodiment and optical device modules including optical devices can be co-mounted.

[0133] FIG. **20** is a schematic view showing an array oscillator **170** where the oscillator modules and the optical device modules are co-mounted. As shown in FIG. **20**, the array oscillator **170** includes the oscillator modules **120** and optical device modules **171**. Other configurations of the array oscillator **170** are the same as those of the array oscillator **121**.

[0134] Each optical device module **171** includes an optical device **172**, a lower electrode layer **173**, a backing layer **174**, and a circuit chip **175**. The optical device **172** is a light-

emitting device, and is a laser diode, for example. The configurations of the lower electrode layer **173**, the backing layer **174**, and the circuit chip **175** are the same as those of the oscillator module **120**. Note that the optical device module **171** is not limited to this, and may at least include the optical device **172**.

[0135] FIG. **21** is a schematic view showing an arrangement of the oscillator modules **120** and the optical device modules **171** of the array oscillator **170**, and is viewed from the direction perpendicular to the substrate **122**. As shown in FIG. **21**, the oscillator modules **120** and the optical device modules **171** are co-mounted on the substrate **122** to form the array. Note that the arrangement of the oscillator modules **120** and the optical device modules **171** is not limited to that shown in FIG. **21**.

[0136] With this configuration, it is possible to execute light ultrasonic imaging, in which the object to be diagnosed is irradiated with light generated by the optical device modules **171** and the oscillator modules **120** detect the generated heat to thereby perform imaging.

[0137] In the related art, it is necessary to separately prepare a light-emitting apparatus including optical devices and an acoustic apparatus including acoustic devices for light ultrasonic imaging. According to the present technology, the ultrasonic oscillators **130** and the optical devices **172** can be formed as an array, and it is possible to perform light ultrasonic imaging with a single ultrasonic probe.

[0138] FIG. **22** is a schematic view showing a method of producing an array oscillator **170**. As shown in FIG. **22**, both of the oscillator modules **120** and the optical device modules **171** can be mounted to the substrate **122** by using the pick-and-place method. After both the modules are mounted to the substrate **122**, the filler **127**, the upper electrode layer **124**, the acoustic matching layer **125**, and the acoustic lens **126** are formed. As a result, it is possible to produce the array oscillator **170** shown in FIG. **20**, similar to the array oscillator **121**.

[0139] Note that the array oscillator **170** can include the above-described MEMS modules **161** in place of the oscillator modules **120**. Further, the array oscillator **170** can include three types of modules, i.e., the oscillator modules **120**, the MEMS modules **161**, and the optical device modules **171**, as an array.

[0140] Other than the array oscillator **160** and the array oscillator **170**, any devices, which can be mounted by using the pick-and-place method, can be co-mounted together with the oscillator modules **120** and can be arrayed together with the oscillator modules **120**.

[0141] The present technology may also have the following configurations.

[0142] (1) An ultrasonic array oscillator, including:

[0143] ultrasonic oscillators that form an array; and

[0144] semiconductor chips bonded to the respective ultrasonic oscillators that form impedance matching circuits.

[0145] (2) The ultrasonic array oscillator according to (1), in which

[0146] each of the impedance matching circuits includes an amplifier and a TR (transmit-receive) switch.

[0147] (3) The ultrasonic array oscillator according to (1), in which

[0148] each of the semiconductor chips includes a first semiconductor chip including the amplifier and a second semiconductor chip including the TR switch.

[0149] (4) The ultrasonic array oscillator according to according to any one of (1) to (3), in which

[0150] each of the semiconductor chips is an SOI (Silicon on Insulator) chip.

[0151] (5) The ultrasonic array oscillator according to according to any one of (1) to (4), in which

[0152] the ultrasonic oscillators include first ultrasonic oscillators each having a first frequency as a center frequency of oscillation and second ultrasonic oscillators each having a second frequency different from the first frequency as a center frequency of oscillation.

[0153] (6) The ultrasonic array oscillator according to according to any one of (1) to (5), further including:

[0154] MEMS (Micro Electro Mechanical Systems), the MEMS and the ultrasonic oscillators forming the array.

[0155] (7) The ultrasonic array oscillator according to according to any one of (1) to (6), further including:

[0156] optical devices, the optical devices and the ultrasonic oscillators forming the array.

[0157] (8) A method of producing an ultrasonic array oscillator, including:

[0158] mounting ultrasonic oscillators, to which semiconductor chips that form impedance matching circuits are bonded, by using a pick-and-place method.

[0159] (9) The method of producing the ultrasonic array oscillator according to according to (8), in which

[0160] the ultrasonic oscillators include first ultrasonic oscillators each having a first frequency as a center frequency of oscillation and second ultrasonic oscillators each having a second frequency different from the first frequency as a center frequency of oscillation.

[0161] (10) The method of producing the ultrasonic array oscillator according to according to (8) or (9), in which

[0162] the mounting step includes mounting the ultrasonic oscillators and MEMS (Micro Electro Mechanical Systems) by using the pick-and-place method.

[0163] (11) The method of producing the ultrasonic array oscillator according to any one of (8) to (10), in which

[0164] the mounting step includes mounting the ultrasonic oscillators and optical devices by using the pick-and-place method.

[0165] (12) An ultrasonic probe, including:

[0166] an ultrasonic array oscillator including ultrasonic oscillators that form an array, and semiconductor chips bonded to respective of the ultrasonic oscillators that form impedance matching circuits.

[0167] (13) An ultrasonic diagnostic apparatus, including:

[0168] an ultrasonic probe including an ultrasonic array oscillator, the ultrasonic array oscillator including ultrasonic oscillators that form an array, and semiconductor chips bonded to respective of the ultrasonic oscillators that form impedance matching circuits; and

[0169] a main body to which the ultrasonic probe is connected, the main body supplying the ultrasonic array oscillator with a drive signal and generating an ultrasonic image on the basis of a detection signal output from the ultrasonic array oscillator.

REFERENCE SIGNS LIST

- [0170] 1 ultrasonic diagnostic apparatus
 - [0171] 11 main body
 - [0172] 12 ultrasonic probe
 - [0173] 120 oscillator module
 - [0174] 121 array oscillator
 - [0175] 122 substrate
 - [0176] 123 oscillator layer
 - [0177] 124 upper electrode layer
 - [0178] 125 acoustic matching layer
 - [0179] 126 acoustic lens
 - [0180] 127 filler
 - [0181] 130 ultrasonic oscillator
 - [0182] 131 piezoelectric layer
 - [0183] 132 lower electrode layer
 - [0184] 133 backing layer
 - [0185] 160 array oscillator
 - [0186] 161 MEMS module
 - [0187] 170 array oscillator
 - [0188] 171 optical device module
1. An ultrasonic array oscillator, comprising: ultrasonic oscillators that form an array; and semiconductor chips bonded to the respective ultrasonic oscillators that form impedance matching circuits.
 2. The ultrasonic array oscillator according to claim 1, wherein each of the impedance matching circuits includes an amplifier and a TR (transmit-receive) switch.
 3. The ultrasonic array oscillator according to claim 2, wherein each of the semiconductor chips includes a first semiconductor chip including the amplifier and a second semiconductor chip including the TR switch.
 4. The ultrasonic array oscillator according to claim 1, wherein each of the semiconductor chips is an SOI (Silicon on Insulator) chip.
 5. The ultrasonic array oscillator according to claim 1, wherein the ultrasonic oscillators include first ultrasonic oscillators each having a first frequency as a center frequency of oscillation and second ultrasonic oscillators each having a second frequency different from the first frequency as a center frequency of oscillation.
 6. The ultrasonic array oscillator according to claim 1, further comprising:

- MEMS (Micro Electro Mechanical Systems), the MEMS and the ultrasonic oscillators forming the array.
7. The ultrasonic array oscillator according to claim 1, further comprising: optical devices, the optical devices and the ultrasonic oscillators forming the array.
 8. A method of producing an ultrasonic array oscillator, comprising: mounting ultrasonic oscillators, to which semiconductor chips that form impedance matching circuits are bonded, by using a pick-and-place method.
 9. The method of producing the ultrasonic array oscillator according to claim 8, wherein the ultrasonic oscillators include first ultrasonic oscillators each having a first frequency as a center frequency of oscillation and second ultrasonic oscillators each having a second frequency different from the first frequency as a center frequency of oscillation.
 10. The method of producing the ultrasonic array oscillator according to claim 8, wherein the mounting step includes mounting the ultrasonic oscillators and MEMS (Micro Electro Mechanical Systems) by using the pick-and-place method.
 11. The method of producing the ultrasonic array oscillator according to claim 8, wherein the mounting step includes mounting the ultrasonic oscillators and optical devices by using the pick-and-place method.
 12. An ultrasonic probe, comprising: an ultrasonic array oscillator including ultrasonic oscillators that form an array, and semiconductor chips bonded to respective of the ultrasonic oscillators that form impedance matching circuits.
 13. An ultrasonic diagnostic apparatus, comprising: an ultrasonic probe including an ultrasonic array oscillator, the ultrasonic array oscillator including ultrasonic oscillators that form an array, and semiconductor chips bonded to respective of the ultrasonic oscillators that form impedance matching circuits; and a main body to which the ultrasonic probe is connected, the main body supplying the ultrasonic array oscillator with a drive signal and generating an ultrasonic image on the basis of a detection signal output from the ultrasonic array oscillator.

* * * * *

专利名称(译)	超声阵列振荡器，制造超声阵列振荡器的方法，超声波探头和超声波诊断装置		
公开(公告)号	US20180235574A1	公开(公告)日	2018-08-23
申请号	US15/752911	申请日	2016-06-16
[标]申请(专利权)人(译)	索尼公司		
申请(专利权)人(译)	索尼公司		
当前申请(专利权)人(译)	索尼公司		
[标]发明人	MORIMOTO RUI		
发明人	MORIMOTO, RUI		
IPC分类号	A61B8/00 B06B1/02 B06B1/06		
CPC分类号	A61B8/4455 A61B8/4281 A61B8/4483 B06B1/0207 B06B1/0622 A61B8/10 B06B1/0215 B06B1/0269 B06B1/0625 B06B2201/20 H04R17/00		
优先权	2015175699 2015-09-07 JP		
外部链接	Espacenet USPTO		

摘要(译)

[目的]提供一种超声阵列振荡器，具有高阻抗匹配效果和优异的生产率的超声阵列振荡器，超声探头和超声波诊断装置的制造方法。[解决方案]根据本技术的超声阵列振荡器包括超声波振荡器（130）和半导体芯片（140）。超声波振荡器（130）形成阵列。半导体芯片（140）接合到相应的超声波振荡器（130）以形成阻抗匹配电路。

