



US 20090062655A1

(19) **United States**

(12) **Patent Application Publication**  
**Saito**

(10) **Pub. No.: US 2009/0062655 A1**  
(43) **Pub. Date: Mar. 5, 2009**

(54) **ULTRASONIC PROBE**

Jan. 31, 2006 (JP) ..... 2006-023170

(75) Inventor: **Koetsu Saito, Tokyo (JP)**

**Publication Classification**

Correspondence Address:  
**PEARNE & GORDON LLP**  
**1801 EAST 9TH STREET, SUITE 1200**  
**CLEVELAND, OH 44114-3108 (US)**

(51) **Int. Cl.**  
**A61B 8/14** (2006.01)  
(52) **U.S. Cl.** ..... **600/459**

(73) Assignee: **MATSUSHITA ELECTRIC INDUSTRIAL CO., LTD., Osaka (JP)**

(57) **ABSTRACT**

(21) Appl. No.: **12/162,584**

An ultrasonic probe is provided capable of eliminating difficulties in processing, increasing the directivity of ultrasonic waves, and obtaining a high-resolution diagnostic image. An ultrasonic probe **10** is configured to include a plurality of piezoelectric elements **1**, an acoustic matching layer **2** provided on a front surface in the thickness direction at a subject side (upper side in the drawing) so as to correspond to the respective piezoelectric elements **1**, a backing load member **3** provided, as necessary, on a rear surface (lower surface in the drawing) in the thickness direction of the piezoelectric elements **1** at a side opposite to the acoustic matching layer **2**, and an acoustic lens **4** provided, as necessary, on the acoustic matching layer **2**. The acoustic matching layer **2** is formed of a rubber elastic material and arranged in a non-divided, flat surface shape at one side of the plurality of piezoelectric elements **1**.

(22) PCT Filed: **Jan. 25, 2007**

(86) PCT No.: **PCT/JP2007/051191**

§ 371 (c)(1),  
(2), (4) Date: **Jul. 29, 2008**

(30) **Foreign Application Priority Data**

Jan. 31, 2006 (JP) ..... 2006-023169

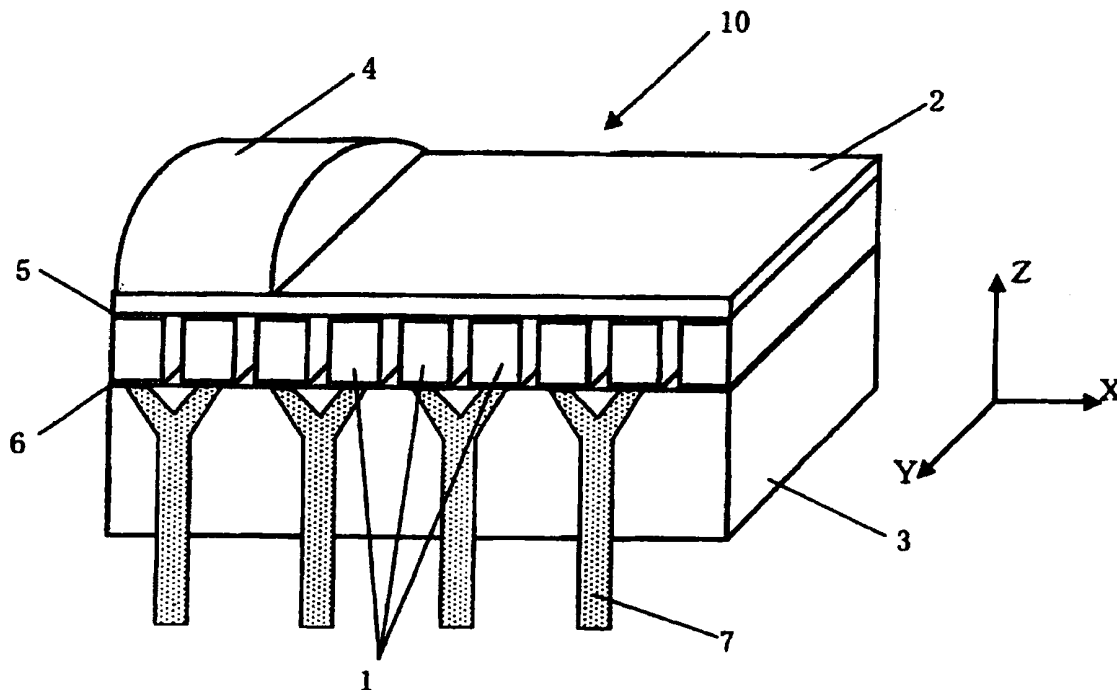

FIG. 1

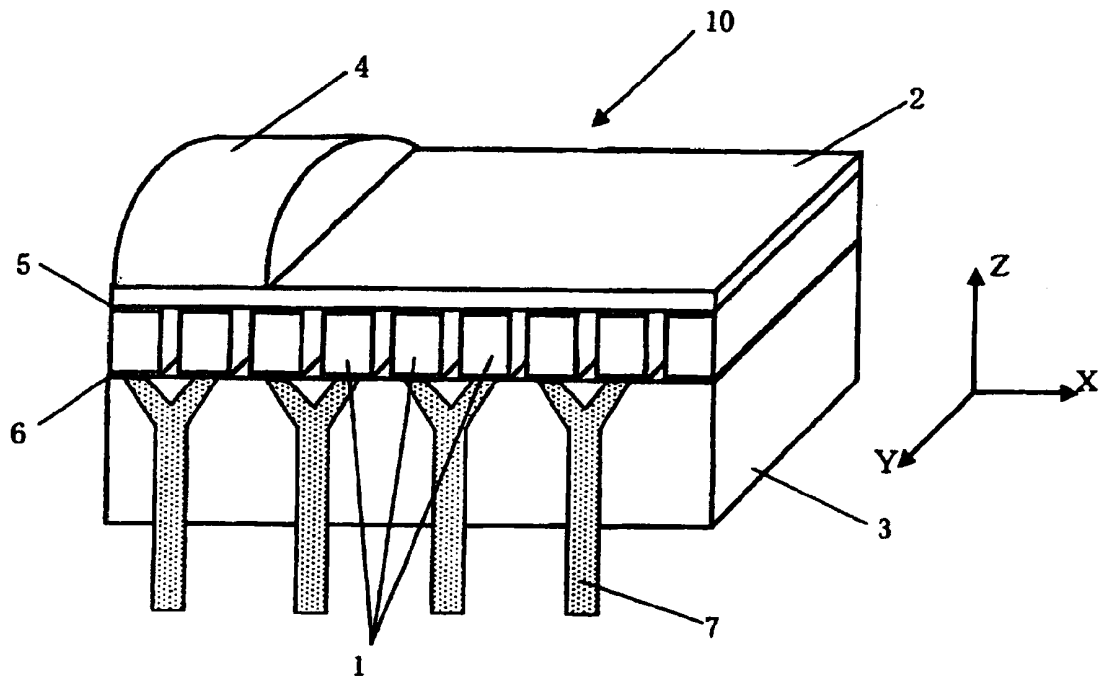

FIG. 2

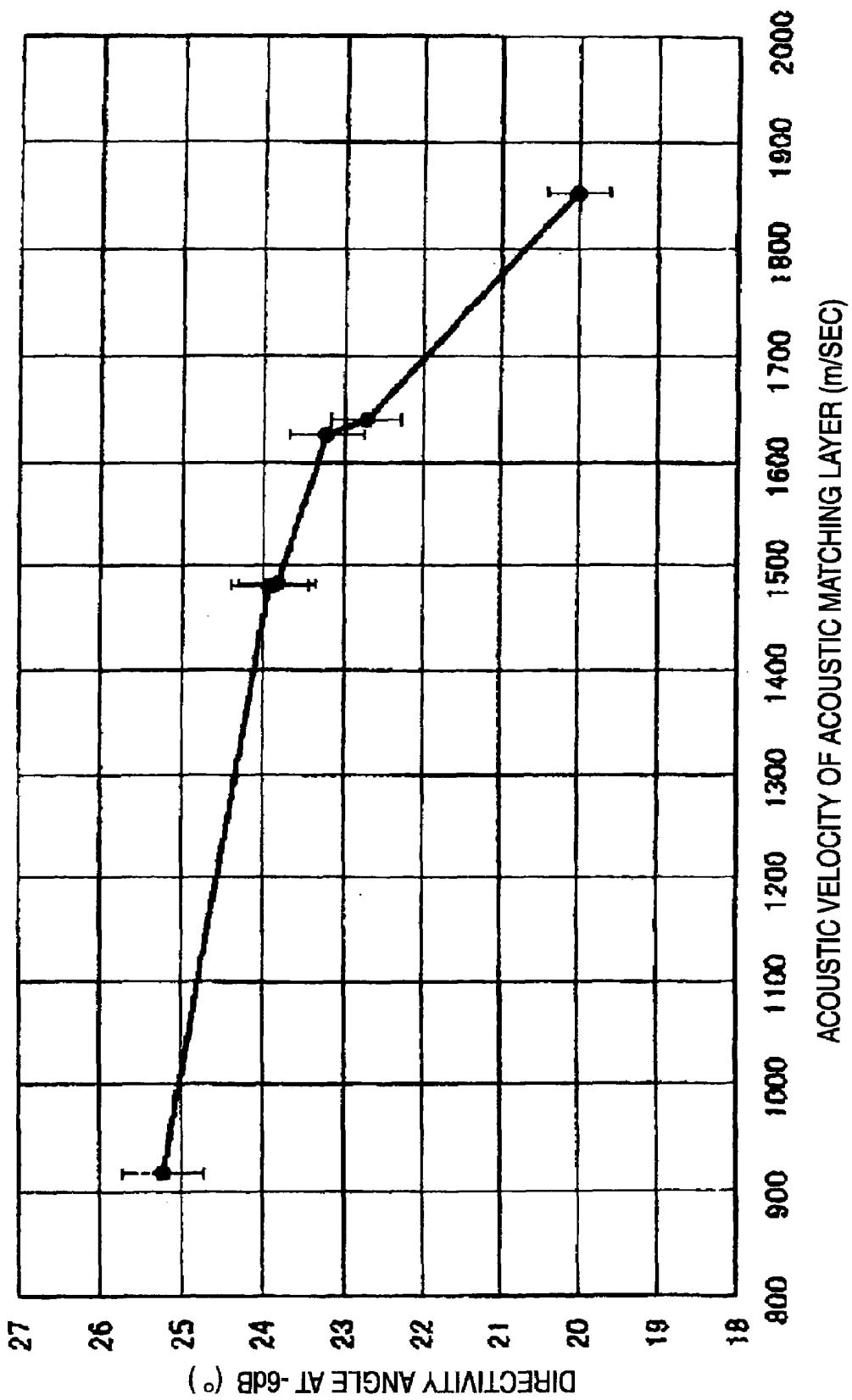



FIG. 5

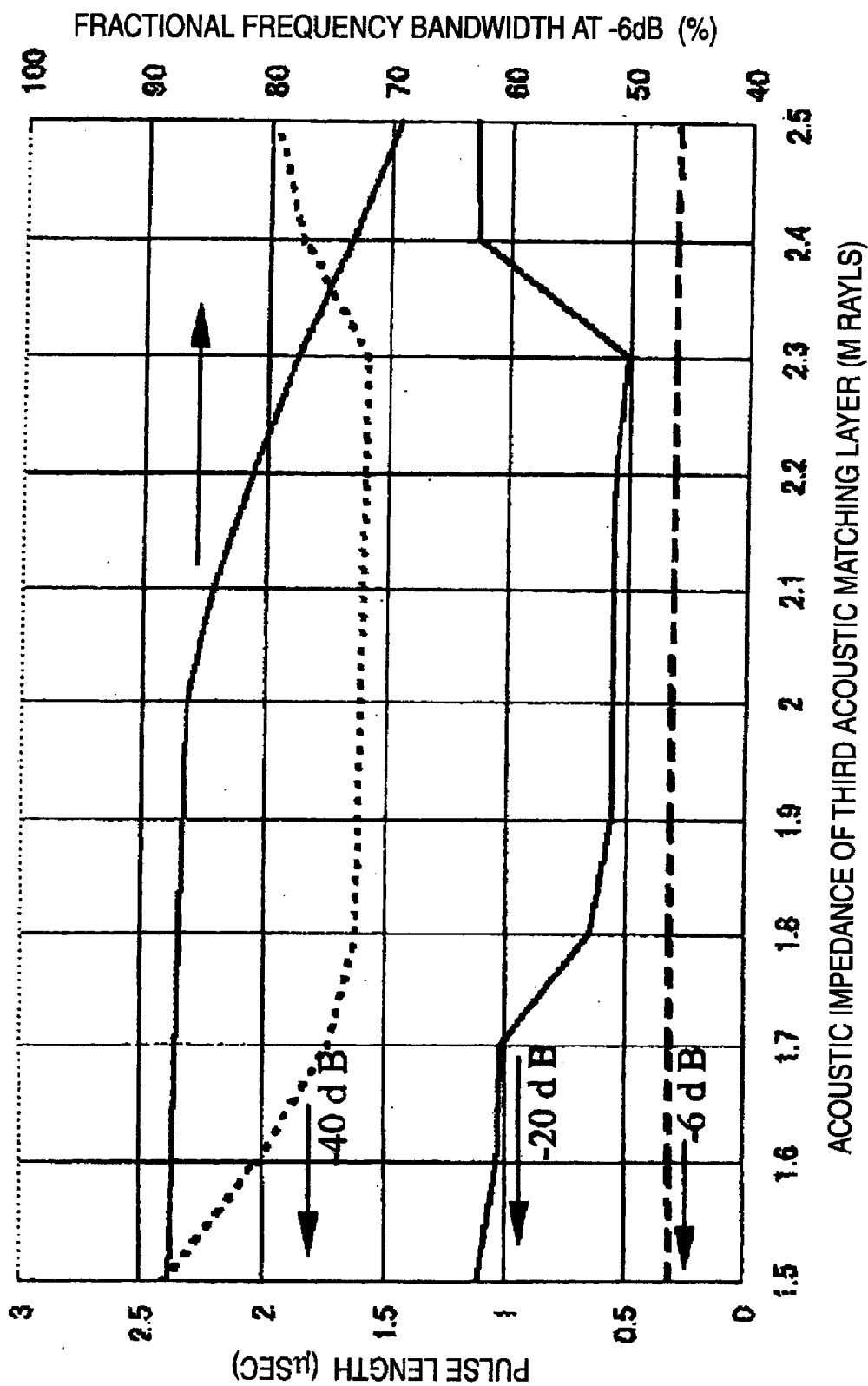

FIG. 6

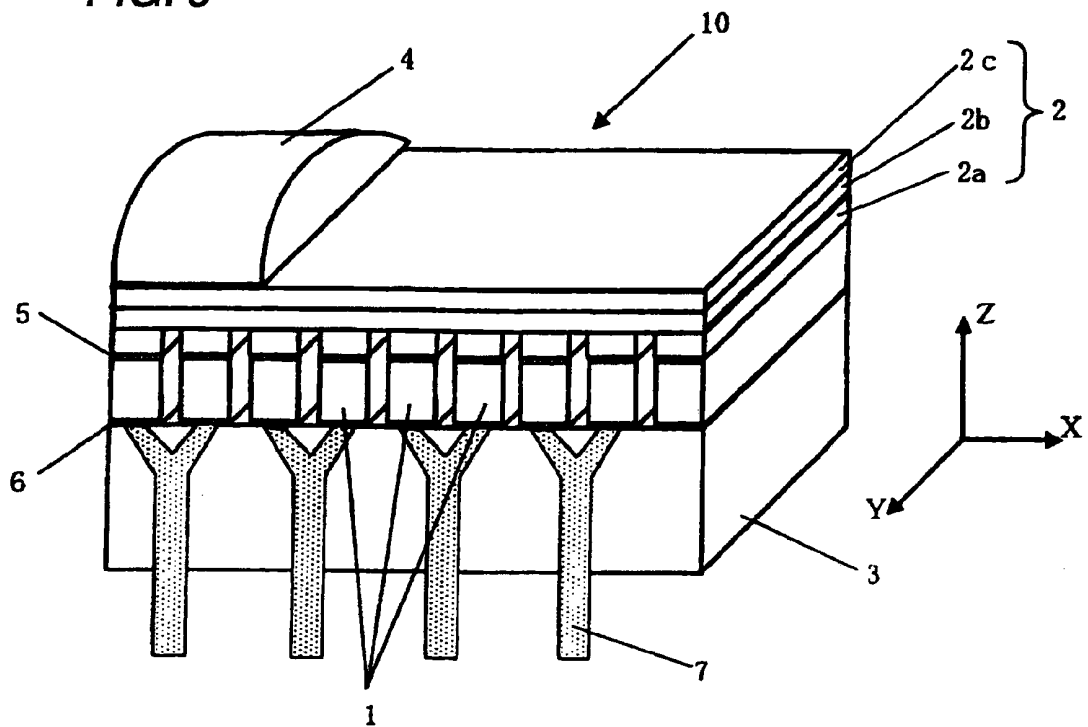

FIG. 7

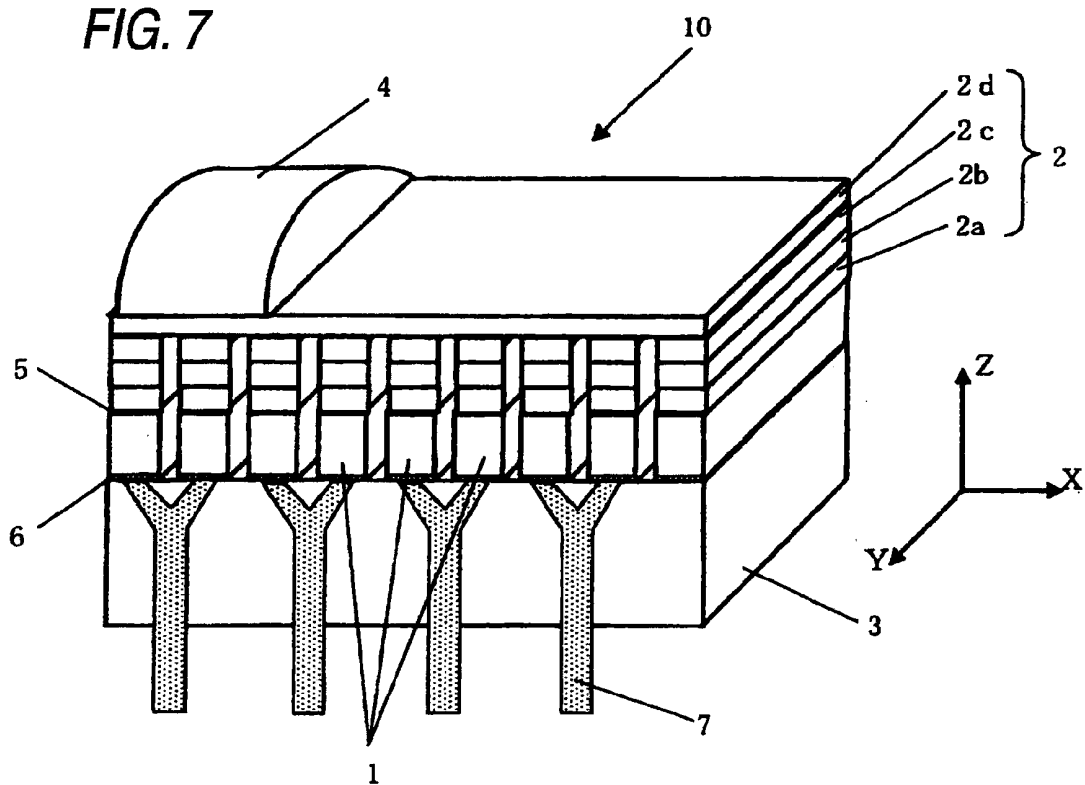

FIG. 8

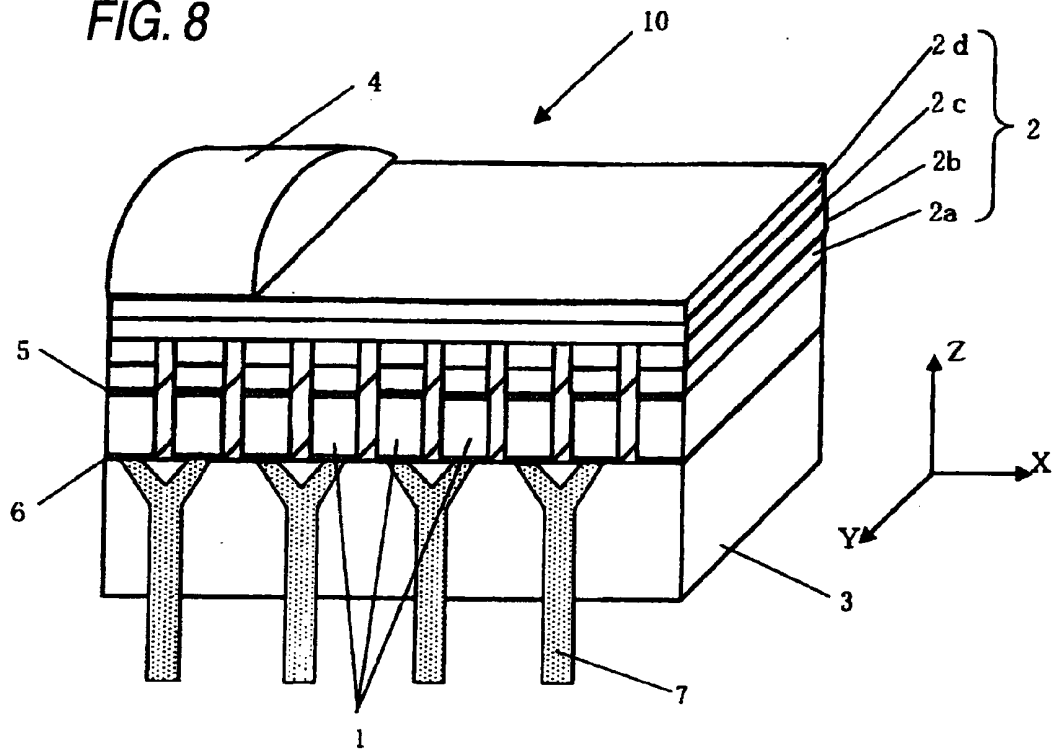

FIG. 9A

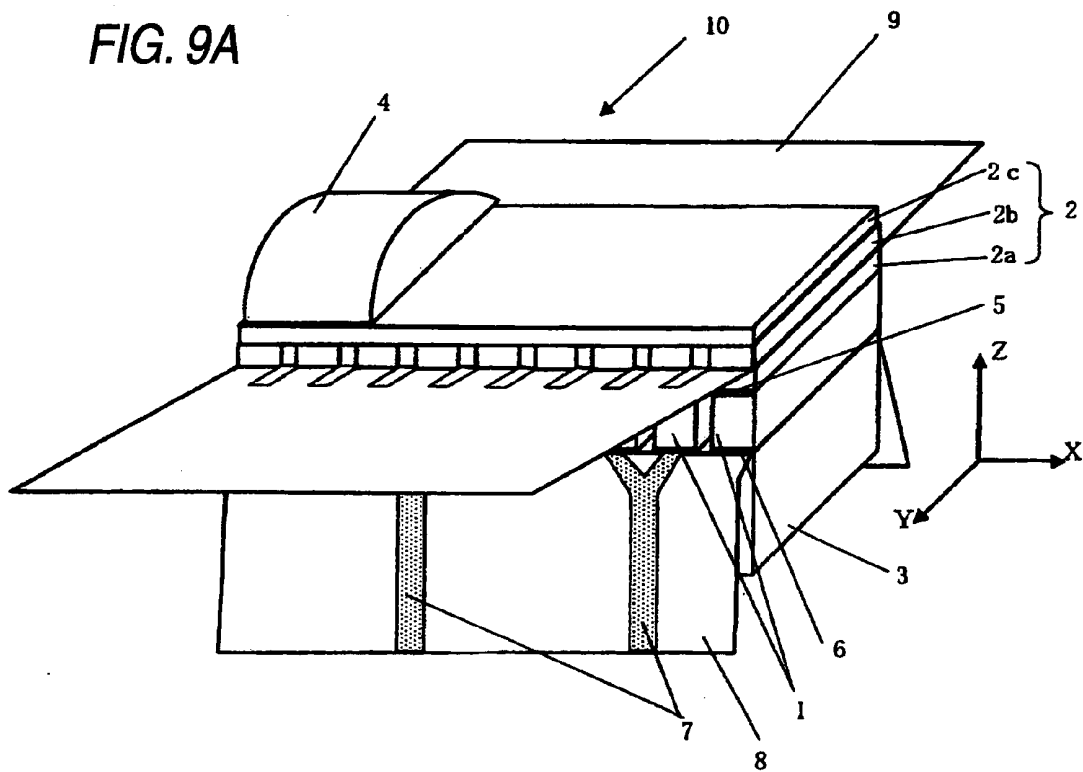

FIG. 9B

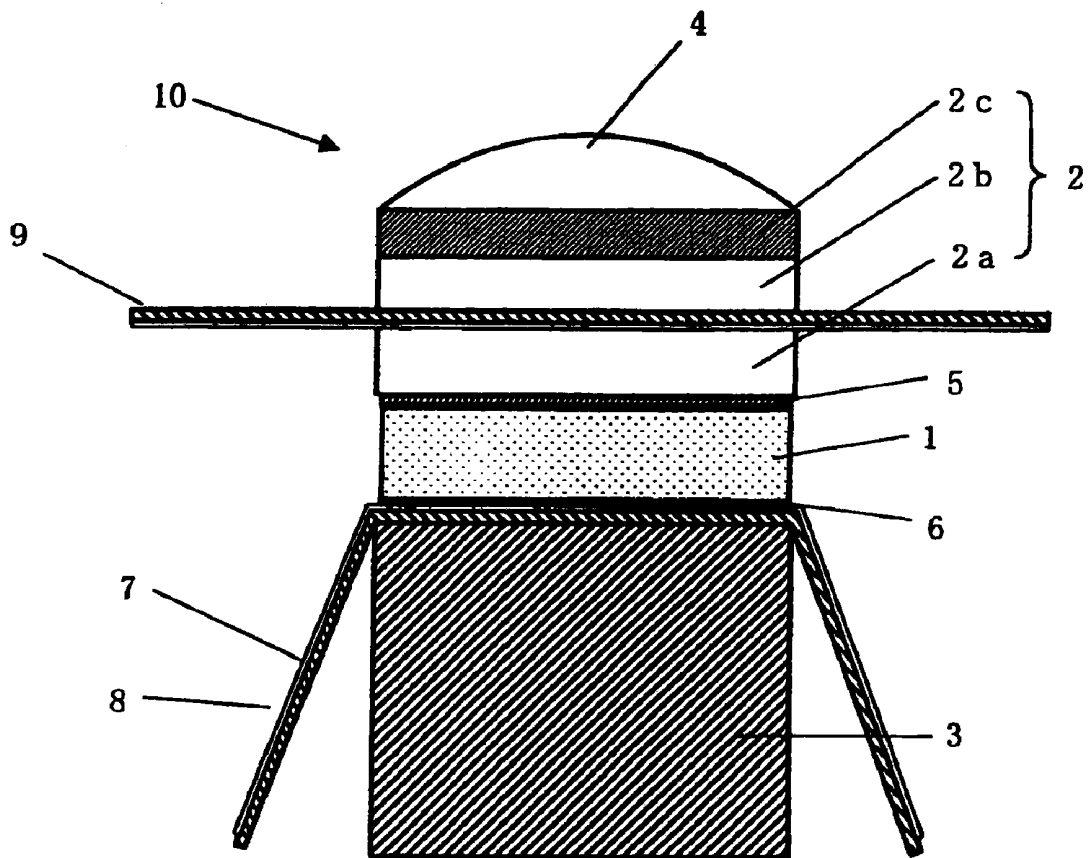

FIG. 10

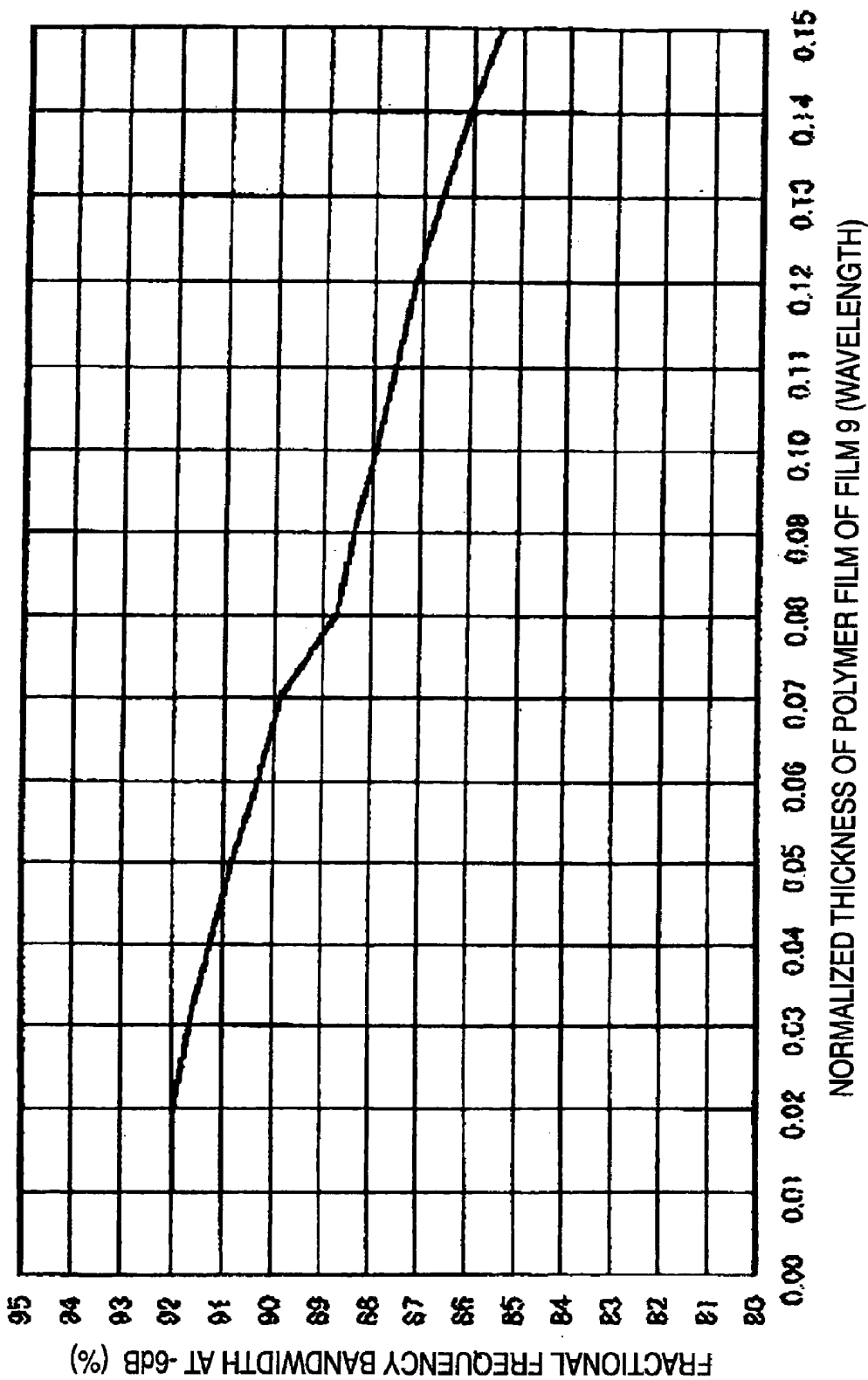

FIG. 11

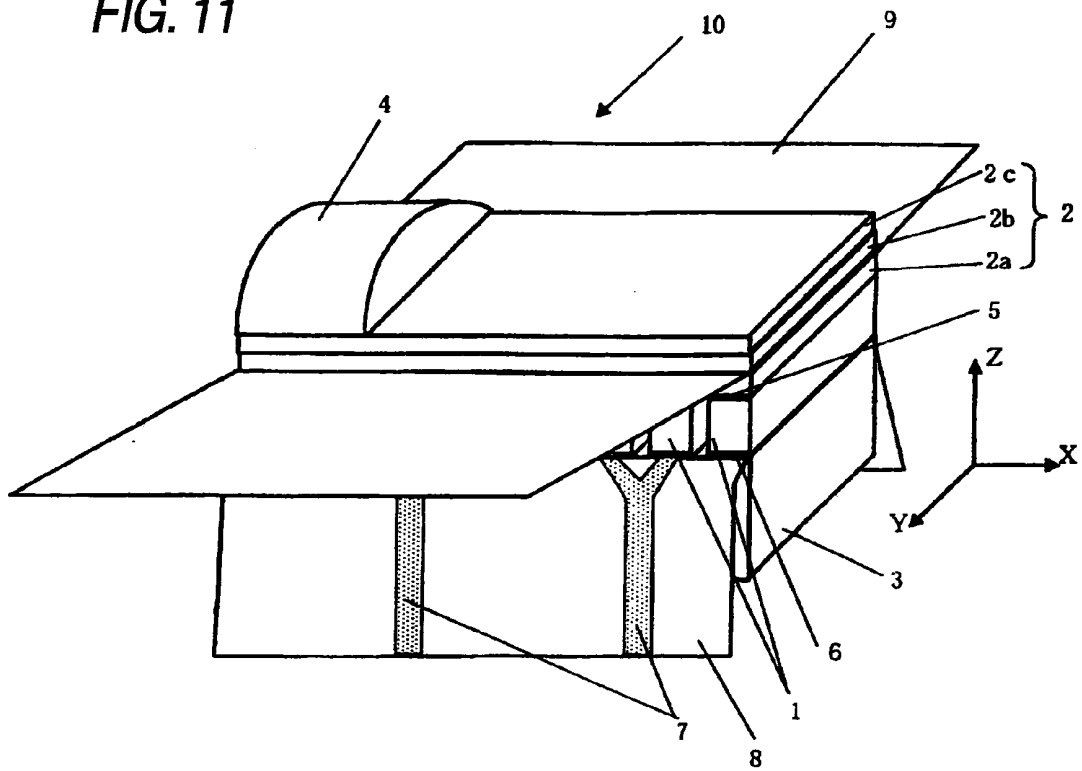
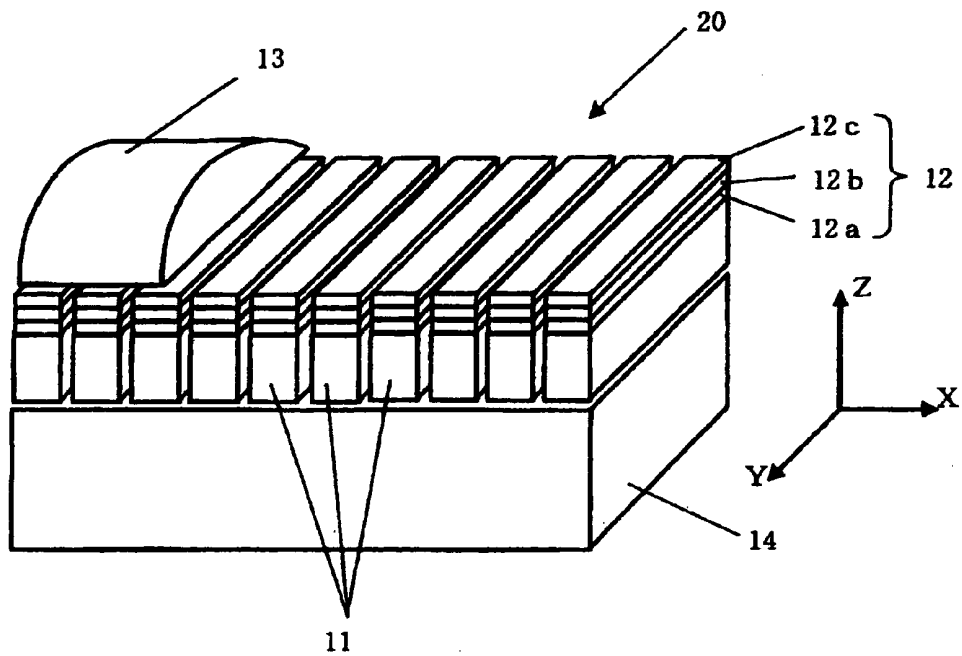

FIG. 12



## ULTRASONIC PROBE

### TECHNICAL FIELD

[0001] The present invention relates to an ultrasonic probe used for transmission and reception of ultrasonic waves to and from a subject such as a living body.

### BACKGROUND ART

[0002] An ultrasonic diagnostic apparatus irradiates ultrasonic waves to the inside of a subject, especially a living body, such as a person or an animal to detect an echo signal reflected from the inside of the living body and then displays tomographic images of tissues inside the living body, thereby providing information necessary for diagnosis of the subject. In such a case, the ultrasonic diagnostic apparatus uses an ultrasonic probe in order to transmit the ultrasonic waves to the inside of the subject and receive the echo signal from the inside of the subject.

[0003] FIG. 12 illustrates an example of such an ultrasonic probe. In FIG. 12, an ultrasonic probe 20 is configured to include a plurality of piezoelectric elements 11 arranged in a predetermined direction so as to transmit and receive ultrasonic waves to and from a subject (not shown), one or more (three layers are illustrated) acoustic matching layer 12 (12a, 12b and 12c) provided on a front surface (upper surface in FIG. 12) at a subject side of the piezoelectric elements 11, an acoustic lens 13 provided on a surface at the subject side of the acoustic matching layer 12, and a backing load member 14 provided on a rear surface of the piezoelectric elements 11 at a side opposite to the acoustic matching layer 12.

[0004] Unillustrated electrodes are disposed on the front surface and the rear surface of the piezoelectric elements 11, respectively so that electric signals can be transmitted and received to and from the piezoelectric elements 11. The piezoelectric elements 11 are formed of PZT-based piezoelectric ceramic materials, or single-crystal piezoelectric materials, a piezoelectric composite made of the materials and polymers, or piezoelectric polymers typified by PVDF or the like. The piezoelectric elements 11 are configured to convert a voltage into ultrasonic waves to be transmitted to the inside of the subject or to convert an echo signal reflected from the inside of the subject into an electric signal to be received thereto. In the illustrated example, the plurality of piezoelectric elements 11 is arranged in the X direction. Such an arrangement of the plurality of piezoelectric elements 11 allows electronically scanning ultrasonic waves to be deflected or converged, thereby enabling a so-called electronic scanning.

[0005] The acoustic matching layer 12 is provided in order to efficiently transmit and receive ultrasonic waves to and from the inside of the subject. More specifically, the acoustic matching layer 12 performs a function of gradually matching an acoustic impedance of the piezoelectric elements 11 to an acoustic impedance of the subject. In the illustrated example, although three acoustic matching layers 12a, 12b, and 12c are provided, the acoustic matching layers may have one, two, or four or more layers. Moreover, in the illustrated example, although the acoustic matching layer 12 is integrally formed on the plurality of piezoelectric elements 11, the acoustic matching layer 12 is divided so as to correspond to the respective piezoelectric elements 11. Furthermore, there is known a structure that can increase the directivity of ultrasonic waves (for example, see Patent Documents 1 and 2).

[0006] The acoustic lens 13 performs a function of condensing an ultrasonic beam in order to increase resolution of a diagnostic image. In the illustrated example, the acoustic lens 13 extends in the Y direction shown in the drawing (a direction orthogonal to the arrangement direction X of the piezoelectric elements 11) with a semi-circular shape that is convex in the Z direction, and is capable of narrowing the ultrasonic waves in the Y direction. The acoustic lens 13 is an optional element and thus will be provided as necessary.

[0007] The backing load member 14 performs a function of holding the piezoelectric elements 11 by being coupled to them and attenuating unnecessary ultrasonic waves. In the drawings of this specification, the X direction will be referred to as "the arrangement direction (of the piezoelectric elements)," the Y direction will be referred to as "the width direction (of the piezoelectric elements)," and the Z direction will be referred to as "the thickness direction (of the piezoelectric elements)."

[0008] Patent Document 1: Japanese Patent Application Laid-Open Publication No. 2003-125494

[0009] Patent Document 2: Japanese Patent Application Laid-Open Publication No. 2005-198261

### DISCLOSURE OF THE INVENTION

#### Problems to be Solved by the Invention

[0010] In such an electronic scanning type ultrasonic diagnostic apparatus, piezoelectric elements are grouped arbitrarily and individual piezoelectric elements are driven with a predetermined delay time, so that ultrasonic waves are transmitted and received between the piezoelectric elements and a subject. By having such a delay time, the ultrasonic waves are converged or diverged, and it is thus possible to provide an ultrasonic image having a broad viewing width or high resolution.

[0011] Such a configuration is already known as a generalized system. In order for an ultrasonic probe to be able to provide such a high-resolution ultrasonic image, it is important to increase the directivity of the ultrasonic beam radiated to the subject through the acoustic matching layer, and moreover, the acoustic lens, as necessary, from the individual ones of the plurality of piezoelectric elements arranged in a predetermined direction, performing electronic scanning.

[0012] The electronic scanning type ultrasonic probe is configured to delay respective transmission and reception times of piezoelectric elements (for example, 64 elements) belonging to an arbitrary one of a plurality of groups to perform phase control, so that the ultrasonic beam is focused at a desired position and narrowed for higher resolution imaging, or the ultrasonic beam is deflected to be scanned in a fan-like shape.

[0013] In such a case, when the number of piezoelectric elements used in each group is increased (for example, from 64 elements to 96 elements), the aperture of the ultrasonic beam is increased correspondingly, and thus the beam can be condensed strongly, that is, narrowed much more, with the result that it is possible to provide improved resolution.

[0014] However, if the directivity of the individual piezoelectric elements is not broad, no matter how much the aperture is increased (the number of elements to which electric signals are applied with delay is increased), non-contributing piezoelectric elements may be present, with the result that the aperture is narrowed and it is thus impossible to narrow and

condense the ultrasonic beam. In this regard, in order to increase the aperture, it is desirable to increase the directivity of the piezoelectric elements.

**[0015]** As one measure for increasing the directivity, Patent Document 1 discloses a configuration in which the entire acoustic matching layers are divided so as to correspond to a plurality of piezoelectric elements arranged in a predetermined direction, and in which acoustic coupling between adjacent ones of the piezoelectric elements and between the acoustic matching layers is suppressed as much as possible.

**[0016]** However, in the above-mentioned configuration, it is necessary to divide and arrange the piezoelectric elements for each of the acoustic matching layers, and when the number of acoustic matching layers is increased in order to increase the frequency bandwidth of ultrasonic waves, the division processing is complicated, and it is thus difficult to provide an ultrasonic probe having stable characteristics.

**[0017]** In recent years, the frequency bandwidth used in the ultrasonic probe is becoming broad and a plurality of frequencies is often used. In this respect, in order to obtain a high-resolution ultrasonic image, it is increasingly important to increase the directivity of the ultrasonic probe while providing a broader bandwidth.

**[0018]** The present invention has been made in view of the problems encountered in the conventional examples, and an object of the present invention is to provide an ultrasonic probe which is easy to process and capable of obtaining a high-resolution image.

#### Means for Solving the Problems

**[0019]** According to the present invention, there is provided an ultrasonic probe including a plurality of piezoelectric elements; and an acoustic matching layer formed of a rubber elastic material, provided on one surface of the plurality of piezoelectric elements.

**[0020]** According to the configuration described above, since the acoustic matching layer is provided in a non-divided state, it is not necessary to process and divide the acoustic matching layer together with the piezoelectric elements, and thus it is possible to eliminate difficulties in processing and to provide a stable ultrasonic probe. Moreover, since the acoustic matching layer is formed of a rubber elastic material, it is possible to provide directivity characteristics equal to or broader than those of the configuration where the acoustic matching layer is divided. Accordingly, phase control can be freely performed by using a greater number of piezoelectric elements, and thus an ultrasonic beam can be condensed narrow. Furthermore, since the ultrasonic beam can be deflected, it is possible to provide an ultrasonic probe capable providing a high-resolution ultrasonic image.

**[0021]** Moreover, the ultrasonic probe according to the present invention is configured such that an acoustic impedance of the rubber elastic material is smaller than an acoustic impedance of the piezoelectric elements and larger than an acoustic impedance of the subject.

**[0022]** According to the configuration described above, since the acoustic impedance of the rubber elastic material is smaller than the acoustic impedance of the piezoelectric elements and larger than the acoustic impedance of the subject, the acoustic impedance of the piezoelectric can be gradually approached to the acoustic impedance of the subject, and thus, ultrasonic waves can be transmitted to and received from the inside of the subject in an efficient manner.

**[0023]** Moreover, the ultrasonic probe according to the present invention is configured such that an acoustic velocity of the acoustic matching layer has a value of 1650 m/sec or less.

**[0024]** According to the configuration described above, since the acoustic velocity of the acoustic matching layer has a value of 1650 m/sec or less, even when the acoustic matching layer is not divided, it is possible to provide directivity characteristics equal to or broader than those of a configuration where the acoustic matching layer is divided.

**[0025]** Moreover, the ultrasonic probe according to the present invention is configured to further include an acoustic matching layer disposed between the acoustic matching layer and the plurality of piezoelectric elements and individually arranged so as to correspond to the respective piezoelectric elements.

**[0026]** According to the configuration described above, since only the acoustic matching layer disposed close to the piezoelectric elements is divided in a manner similar to the piezoelectric elements, even when the piezoelectric elements are divided into narrow intervals (for example, 0.1 mm), the processing can be performed in a stable manner, and thus, it is possible to fabricate the ultrasonic probe in a uniform and precise manner. Moreover, since the divided acoustic matching layer is provided between the flat acoustic matching layer and the plurality of piezoelectric elements, the acoustic impedance of the piezoelectric can be gradually approached to the acoustic impedance of the subject, and thus, ultrasonic waves can be transmitted to and received from the inside of the subject in an efficient manner.

**[0027]** According to the present invention, there is provided an ultrasonic probe including a plurality of piezoelectric elements; a third acoustic matching layer provided on one surface of the plurality of piezoelectric elements and having an acoustic impedance in the range of 1.8 to 2.2 MRayls and an acoustic velocity of 1650 m/sec or less; and first and second acoustic matching layers provided between the third acoustic matching layer and the plurality of piezoelectric elements.

**[0028]** According to the configuration described above, since the third acoustic matching layer has an acoustic impedance in the range of 1.8 to 2.2 MRayls and an acoustic velocity of 1650 m/sec or less, and the first and second acoustic matching layers are provided, the acoustic impedance of the piezoelectric can be gradually approached to the acoustic impedance of the subject, and thus, ultrasonic waves can be transmitted to and received from the inside of the subject in an efficient manner.

**[0029]** Moreover, the ultrasonic probe according to the present invention is configured such that the third acoustic matching layer is provided on one surface of the plurality of piezoelectric elements, and the first and second acoustic matching layers are individually arranged so as to correspond to the respective piezoelectric elements.

**[0030]** According to the configuration described above, since the first and second acoustic matching layers are provided between the third acoustic matching layer and the plurality of piezoelectric elements and are individually arranged so as to correspond to the respective piezoelectric elements, the acoustic impedance of the piezoelectric can be gradually approached to the acoustic impedance of the subject, and thus, ultrasonic waves can be transmitted to and received from the inside of the subject in an efficient manner.

**[0031]** Moreover, the ultrasonic probe according to the present invention is configured such that the third acoustic matching layer is formed of a rubber elastic material.

**[0032]** According to the present invention, there is provided an ultrasonic probe including a plurality of piezoelectric elements; second and third acoustic matching layers provided on one surface of the plurality of piezoelectric elements and having an acoustic velocity of 1650 m/sec or less; and a first acoustic matching layer provided between the second and third acoustic matching layers and the plurality of piezoelectric elements.

**[0033]** According to the configuration described above, since the second and third acoustic matching layers have an acoustic velocity of 1650 m/sec or less, it is possible to provide directivity characteristics equal to or broader than those of the configuration where the acoustic matching layer is divided. Accordingly, phase control can be freely performed by using a greater number of piezoelectric elements, and thus an ultrasonic beam can be condensed narrow. Furthermore, since the ultrasonic beam can be deflected, it is possible to provide an ultrasonic probe capable providing a high-resolution ultrasonic image.

**[0034]** Moreover, the ultrasonic probe according to the present invention is configured such that the second and third acoustic matching layers are provided on one surface of the plurality of piezoelectric elements, and the first acoustic matching layer is individually arranged so as to correspond to the respective piezoelectric elements.

**[0035]** According to the configuration described above, since the second and third acoustic matching layers are provided, it is possible to decrease the number of layers of the acoustic matching layer which is to be divided together with the piezoelectric elements, and thus the difficulties in processing can be eliminated, and a stable ultrasonic probe can be obtained.

**[0036]** Moreover, the ultrasonic probe according to the present invention is configured such that the second and third acoustic matching layers are formed of a rubber elastic material.

**[0037]** According to the present invention, there is provided an ultrasonic probe including a plurality of piezoelectric elements; a fourth acoustic matching layer provided on one surface of the plurality of piezoelectric elements and having an acoustic velocity of 1650 m/sec or less; and first, second and third acoustic matching layers provided between the fourth acoustic matching layer and the plurality of piezoelectric elements.

**[0038]** According to the configuration described above, since the acoustic velocity of the fourth acoustic matching layer has a value of 1650 m/sec or less, it is possible to provide directivity characteristics equal to or broader than those of the configuration where the acoustic matching layer is divided. Moreover, since the first, second and third acoustic matching layers are provided between the fourth acoustic matching layer and the plurality of piezoelectric elements, the acoustic impedance of the piezoelectric can be gradually approached to the acoustic impedance of the subject, and thus, ultrasonic waves can be transmitted to and received from the inside of the subject in an efficient manner.

**[0039]** Moreover, the ultrasonic probe according to the present invention is configured such that the fourth acoustic matching layer is provided on one surface of the plurality of piezoelectric elements, and the first, second and third acoustic

matching layers are individually arranged so as to correspond to the respective piezoelectric elements.

**[0040]** According to the configuration described above, since the fourth acoustic matching layer is provided, it is possible to decrease the number of layers of the acoustic matching layer which is to be divided together with the piezoelectric elements, and thus the difficulties in processing can be eliminated, and a stable ultrasonic probe can be obtained.

**[0041]** Moreover, the ultrasonic probe according to the present invention is configured such that the third and fourth acoustic matching layers are provided on one surface of the plurality of piezoelectric elements, and the first and second acoustic matching layers are individually arranged so as to correspond to the respective piezoelectric elements.

**[0042]** According to the configuration described above, since the third and fourth acoustic matching layers are provided, it is possible to decrease the number of layers of the acoustic matching layer which is to be divided together with the piezoelectric elements, and thus the difficulties in processing can be eliminated, and a stable ultrasonic probe can be obtained.

**[0043]** Moreover, the ultrasonic probe according to the present invention is configured such that the third acoustic matching layer is formed of a rubber elastic material and has an acoustic velocity of 1650 m/sec or less. Furthermore, the ultrasonic probe according to the present invention is configured such that the fourth acoustic matching layer is formed of a rubber elastic material.

**[0044]** According to the configuration described above, since the acoustic matching layer is formed of a rubber elastic material and has an acoustic velocity of 1650 m/sec or less, it is possible to provide directivity characteristics equal to or broader than those of a configuration where the acoustic matching layer is divided.

**[0045]** According to the present invention, there is provided an ultrasonic probe having a backing load member and a plurality of piezoelectric elements arranged on an upper surface of the backing load member, the ultrasonic probe including: a first polymer film provided between the backing load member and the plurality of piezoelectric elements and provided with electric terminals individually arranged so as to correspond to the respective piezoelectric elements; a first acoustic matching layer provided on an upper surface of the plurality of piezoelectric elements and individually arranged so as to correspond to the respective piezoelectric elements; a second polymer film provided on an upper surface of the first acoustic matching layer and provided with electric terminals individually arranged so as to correspond to the respective piezoelectric elements; a second acoustic matching layer provided on an upper surface of the second polymer film and individually arranged so as to correspond to the respective piezoelectric elements; and a third acoustic matching layer provided on an upper surface of the second acoustic matching layer and formed of a rubber elastic material.

**[0046]** According to the configuration described above, since the third acoustic matching layer is formed of a rubber elastic material, it is possible to provide broader frequency bandwidth and increase the directivity. Moreover, since the third acoustic matching layer is provided in a non-divided state, the number of layers of the acoustic matching layer, which is to be divided together with the piezoelectric elements can be decreased, and thus, it is possible to eliminate difficulties in processing. Furthermore, since the electric terminals are provided to the polymer film, the electric terminals

can be formed in an easy manner. Accordingly, phase control can be freely performed by using a greater number of piezoelectric elements, and thus an ultrasonic beam can be condensed narrow. Furthermore, since the ultrasonic beam can be deflected, it is possible to provide an ultrasonic probe capable providing a high-resolution ultrasonic image.

[0047] Moreover, the ultrasonic probe according to the present invention is configured such that an acoustic velocity of the third acoustic matching layer has a value of 1650 m/sec or less. Furthermore, the ultrasonic probe according to the present invention is configured such that an acoustic impedance of the second polymer film is smaller than an acoustic impedance of the second acoustic matching layer and has a thickness of 0.07 wavelength or less at using frequency.

[0048] According to the present invention, there is provided an ultrasonic probe having a backing load member and a plurality of piezoelectric elements arranged on an upper surface of the backing load member, the ultrasonic probe including: a first polymer film provided between the backing load member and the plurality of piezoelectric elements and provided with electric terminals; a first acoustic matching layer provided on an upper surface of the plurality of piezoelectric elements and individually arranged so as to correspond to the respective piezoelectric elements; a second polymer film provided on an upper surface of the first acoustic matching layer and provided with electric terminals individually arranged so as to correspond to the respective piezoelectric elements; a second acoustic matching layer provided on an upper surface of the second polymer film and formed of a rubber elastic material; and a third acoustic matching layer provided on an upper surface of the second acoustic matching layer and formed of a rubber elastic material.

[0049] According to the configuration described above, since the second and third acoustic matching layers are formed of a rubber elastic material, it is possible to provide broader frequency bandwidth and increase the directivity. Moreover, since the second and third acoustic matching layers are provided in a non-divided state, the number of layers of the acoustic matching layer, which is to be divided together with the piezoelectric elements can be decreased, and thus it is possible to eliminate difficulties in processing. Furthermore, since the electric terminals are provided to the polymer film, the electric terminals can be formed in an easy manner. Accordingly, phase control can be freely performed by using a greater number of piezoelectric elements, and thus an ultrasonic beam can be condensed narrow. Furthermore, since the ultrasonic beam can be deflected, it is possible to provide an ultrasonic probe capable providing a high-resolution ultrasonic image.

[0050] Moreover, the ultrasonic probe according to the present invention is configured such that the rubber elastic material is mainly composed of synthetic rubber, silicon rubber, urethane rubber, or elastomer. Furthermore, the ultrasonic probe according to the present invention is configured such that the synthetic rubber is mainly composed of ethylene-propylene copolymer rubber, chloroprene rubber, butadiene rubber, isoprene rubber, styrene-butadiene copolymer rubber, or acrylonitrile-butadiene copolymer rubber.

#### ADVANTAGES OF THE INVENTION

[0051] According to the present invention, since the acoustic matching layer provided on one surface of the piezoelectric elements is formed of a rubber elastic material, it is not necessary to divide the acoustic matching layer and directivity

characteristics equal to or broader than those of the configuration where the acoustic matching layer is divided can be provided. Therefore, it is possible to provide an ultrasonic probe which is easy to process and capable of obtaining a high-resolution diagnostic image.

#### BRIEF DESCRIPTION OF THE DRAWINGS

[0052] FIG. 1 is a schematic perspective view of an ultrasonic probe according to a first embodiment of the present invention.

[0053] FIG. 2 is a diagram illustrating the relationship between an acoustic velocity and a directivity angle of an acoustic matching layer.

[0054] FIG. 3 is a schematic perspective view of an ultrasonic probe according to a second embodiment of the present invention.

[0055] FIG. 4 is a schematic perspective view of an ultrasonic probe according to a third embodiment of the present invention.

[0056] FIG. 5 is a diagram illustrating the relationship between an acoustic impedance, a pulse length, and a fractional bandwidth of a third acoustic matching layer.

[0057] FIG. 6 is a schematic perspective view of an ultrasonic probe according to a fourth embodiment of the present invention.

[0058] FIG. 7 is a schematic perspective view of an ultrasonic probe according to a fifth embodiment of the present invention.

[0059] FIG. 8 is a schematic perspective view of an ultrasonic probe according to a sixth embodiment of the present invention.

[0060] FIG. 9A is a schematic perspective view of the ultrasonic probe according to the first embodiment of the present invention.

[0061] FIG. 9B is a schematic sectional view of the ultrasonic probe according to the first embodiment of the present invention.

[0062] FIG. 10 is a diagram illustrating the relationship between a thickness and a fractional bandwidth of a polymer film.

[0063] FIG. 11 is a schematic perspective view of the ultrasonic probe according to the second embodiment of the present invention.

[0064] FIG. 12 is a schematic perspective view illustrating the configuration of an ultrasonic probe according to a prior art.

#### DESCRIPTION OF REFERENCE NUMBERS

- [0065] 1: PIEZOELECTRIC ELEMENT
- [0066] 2, 2a, 2b, 2c, 2d: ACOUSTIC MATCHING LAYER
- [0067] 3: BACKING LOAD MEMBER
- [0068] 4: ACOUSTIC LENS
- [0069] 5: GROUND ELECTRODE
- [0070] 6: SIGNAL ELECTRODE
- [0071] 7: ELECTRIC TERMINAL
- [0072] 8, 9: FILM
- [0073] 10: ULTRASONIC PROBE
- [0074] 11: PIEZOELECTRIC ELEMENT
- [0075] 12: ACOUSTIC MATCHING LAYER
- [0076] 13: ACOUSTIC LENS
- [0077] 14: BACKING LOAD MEMBER
- [0078] 20: ULTRASONIC PROBE

BEST MODE FOR CARRYING OUT THE  
INVENTION

## Embodiment 1

[0079] Hereinafter, an ultrasonic probe according to a first embodiment of the present invention will be described with reference to the drawings. FIG. 1 is a partially schematic perspective view of an ultrasonic probe 10 according to the first embodiment.

[0080] The ultrasonic probe 10 is configured to include a plurality of piezoelectric elements 1, an acoustic matching layer 2 (first acoustic matching layer) provided on a front surface in the thickness direction at a subject side (upper side in the drawing) so as to correspond to the respective piezoelectric elements 1, a backing load member 3 provided, as necessary, on a rear surface (lower surface in the drawing) in the thickness direction of the piezoelectric elements 1 at a side opposite to the acoustic matching layer 2, and an acoustic lens 4 provided, as necessary, on the acoustic matching layer 2. The respective functions of the above-mentioned components are the same as those of the components described in the prior art.

[0081] A ground electrode 5 and a signal electrode 6 are provided on the front surface and the rear surface in the thickness direction Z of the piezoelectric elements 1, respectively. The electrodes 5 and 6 are formed on the front surface and the rear surface of the piezoelectric elements 1, respectively, by means of deposition or sputtering of gold and silver or silver printing.

[0082] The electrodes 5 and 6 are electrically connected to an unillustrated ultrasonic diagnostic apparatus through a cable via an electric terminal 7, so that a regular pulse voltage generated by the ultrasonic probe is applied to the piezoelectric elements 1, and an echo reception signal converted into an electric signal by the piezoelectric elements 1 is transmitted to a body of the ultrasonic diagnostic apparatus.

[0083] In the illustrated example, the piezoelectric elements 1 are divided into individual ones, and materials, such as silicon rubber or urethane rubber, capable of reducing acoustic coupling are filled in portions corresponding to the division grooves.

[0084] FIG. 2 is a diagram illustrating the relationship between a directivity angle of ultrasonic waves in the arrangement direction X of the plurality of piezoelectric elements 1 illustrated in FIG. 1 and an acoustic velocity of a rubber elastic material of the acoustic matching layer 2. In the ultrasonic probe 10 of a so-called electronic scanning type, having the plurality of piezoelectric elements 1 arranged therein, an important point in increasing the resolution of an ultrasonic image is how the directivity in the X direction of the piezoelectric elements 1 can be increased.

[0085] In the first embodiment, as illustrated in FIG. 1, the piezoelectric elements 1 provided on the backing load member 3 are divided by means of a slicing machine or the like, silicon rubber or urethane rubber is filled in the division grooves, and thereafter, the acoustic matching layer 2 of rubber elastic material is provided on the surface of the divided piezoelectric elements 1.

[0086] As is known, the acoustic matching layer 2 is formed using a material having an acoustic impedance having an intermediate value between those of the piezoelectric elements 1 and a subject (not shown), and having a thickness basically corresponding to a  $\frac{1}{4}$  wavelength of a using frequency. Further, on the surface of the acoustic matching layer

2, the acoustic lens 4 formed of materials such as silicon rubber is provided, as necessary.

[0087] In the prior art, in order to increase the directivity, the acoustic matching layer 2 is placed on the piezoelectric elements 1 and then divided in a manner similar to the piezoelectric elements 1. This is to prevent a situation where ultrasonic waves propagate in the horizontal direction within the acoustic matching layer 2 and thus the directivity is narrowed, because unless the acoustic matching layer 2 is not divided unlike the piezoelectric elements 1, the acoustic matching layer 2 will be continuously connected with each other.

[0088] However, when the piezoelectric elements 1, the acoustic matching layer 2, and moreover, a portion of the backing load member 3 are processed together to be divided by a slicing machine, and in particular, with a division gap as narrow as 0.1 mm, there is a problem that since a plurality of materials is processed together, it is difficult to perform the division processing in a uniform and stable manner.

[0089] The present embodiment is characterized in that only the piezoelectric elements 1 are divided, and the acoustic matching layer 2 of rubber elastic materials is provided on the surface of the divided piezoelectric elements 1 in a one-layer state where the acoustic matching layer is not divided but connected, so that it is easy to process and the processing can be performed in a uniform and stable manner, and that the resulting directivity is equal to or greater than that obtainable from the configuration where the acoustic matching layer 2 is divided.

[0090] The rubber elastic material as the material of the acoustic matching layer 2 uses a material having an acoustic impedance having an intermediate value between those of the piezoelectric elements 1 and the subject and having a thickness basically corresponding to a  $\frac{1}{4}$  wavelength of the using frequency. As a result of the investigation with experiments on various materials, when rubber elastic materials having the same values in hardness and acoustic impedance were used as the acoustic matching layer 2, they showed different directivities.

[0091] For example, an angle of the directivity when the piezoelectric elements 1 having a frequency of 3.5 MHz are divided into intervals of 0.38 mm corresponding to the gaps of the divided piezoelectric elements 1 (a state where two parts divided into intervals of 0.19 mm are electrically coupled), as defined at a level of -6 dB, corresponds to a directivity angle of about 23 degrees for a configuration type where the acoustic matching layer 2 is divided together with the piezoelectric elements 1.

[0092] That is, a direction in which the strength of an ultrasonic beam radiated in the Z direction decreases by -6 dB corresponds to an angle of about 23 degrees from the Z direction. Moreover, it was configured such that silicon rubber materials are filled in the division grooves of the piezoelectric elements 1 and the acoustic matching layer 2.

[0093] In a configuration type where the piezoelectric elements 1 are divided with the same specifications by the above-mentioned method and the acoustic matching layer 2 is not divided as illustrated in FIG. 1, the directivity characteristics of ultrasonic waves in the arrangement direction of the piezoelectric elements 1 were measured in a state where a plurality of acoustic matching layers 2 are prepared, respectively formed of silicon rubber (hardness: 76 on shore A hardness, acoustic velocity: 915 m/sec, acoustic impedance: 2.1 MRayls), chloroprene rubber (hardness: 70 on shore A hardness, acoustic velocity: 1630 m/sec, acoustic impedance: 2.16

MRayls), ethylene-propylene copolymer rubber (hardness: 65 on shore A hardness, acoustic velocity: 1480 m/sec, acoustic impedance: 1.94 MRayls), acrylonitrile-butadiene copolymer rubber (hardness: 60 on shore A hardness, acoustic velocity: 1640 m/sec, acoustic impedance: 1.97 MRayls), and urethane rubber (hardness: 78 on shore A hardness, acoustic velocity: 1850 m/sec, acoustic impedance: 1.98 MRayls), and the respective acoustic matching layers **2** are placed on the surface of the piezoelectric elements **1**, and an acoustic lens formed of silicon rubber is provided on the upper surface of the acoustic matching layer **2**.

[0094] As a result of the measurement, it can be concluded that the directivity characteristics changed depending on the materials of the acoustic matching layer **2**. Moreover, in the division grooves of the divided piezoelectric elements **1**, silicon rubber materials were filled in a manner similar to the configuration where the division is performed up to the acoustic matching layer **2**.

[0095] Moreover, as a material other than the urethane rubber as mentioned above, a material in which an arbitrary amount of fillers such as alumina, carbon or calcium carbonate is filled in order to adjust an acoustic impedance was used.

[0096] The difference in the directivity characteristics of the acoustic matching layers **2** formed of the above-mentioned five kinds of materials was neither correlated with nor influenced by the hardness, the acoustic impedance, and the like of the materials. However, the acoustic velocity characteristics of the materials of the acoustic matching layers **2** had influence on, that is, was correlated with, the directivity characteristics, and showed good correlation.

[0097] The relationship between the directivity angle measured at a level of -6 dB using a frequency of 3.5 MHz and an acoustic velocity of the material is illustrated in FIG. 2. As illustrated in FIG. 2, it showed good correlation with an acoustic velocity, and a correlation coefficient was 0.86. In this respect, in the configuration where the acoustic matching layer **2** is not divided, it can be concluded that it is necessary to focus on the acoustic velocity in order to increase the directivity. The directivity angles when the respective materials were used for the acoustic matching layer **2** are as follows.

[0098] The respective directivity angles were 25 degrees for the silicon rubber, 23.5 degrees for the chloroprene rubber, 23.5 degrees for the ethylene-propylene copolymer rubber, 22.9 degrees for the acrylonitrile-butadiene copolymer rubber, and 20 degrees for the urethane rubber. Moreover, it is considered that the measurement result has a deviation of about  $\pm 0.5$  degrees.

[0099] When the directivity angles were compared with the directivity angle of the prior art configuration where the acoustic matching layer **2** is divided together with the piezoelectric elements **1**, in order to obtain a directivity angle approximately equal to the directivity angle of the prior art configuration, it is necessary to form the acoustic matching layer **2** using a material having an acoustic velocity in the vicinity of 1650 m/sec. Moreover, in order to increase the directivity, it can be concluded from the result illustrated in FIG. 2 that it is necessary to use a material having an acoustic velocity of 1650 m/sec or less, for example, a material such as silicon rubber.

[0100] Moreover, in the case of the urethane rubber which showed a narrow directivity angle, since among urethane rubbers, some kinds of products (for example, medium-size urethane resin of a grade UE-644, manufactured by SANYU

REC Co., Ltd. has an acoustic velocity of 1580 m/sec and an acoustic impedance of 2.1 MRayls) have an acoustic velocity in the vicinity of 1650 m/sec or less, it cannot be said that the urethane rubber narrows the directivity angle, and the directivity angle is determined by an acoustic velocity. Therefore, when materials having an acoustic velocity of 1650 m/sec or less are selected, the materials are basically narrowed down to the rubber elastic materials.

[0101] As described above, in the configuration where the acoustic matching layer **2** is not divided unlike the piezoelectric elements **1** but is provided as one sheet of continuous film, in order to secure or increase the directivity, it can be concluded that it is necessary to focus on an acoustic velocity of the material of the acoustic matching layer **2**.

[0102] For example, a material having an acoustic impedance of about 2 MRayls as the materials mentioned above is not limited to the rubber elastic materials but plastic materials are also usable. For example, materials in which filling materials are filled in polyethylene resin, polystyrene resin, or the epoxy resin described in Patent Document 2 may be used, and such materials have an acoustic velocity of about 1800 m/sec or more. When the acoustic matching layer **2** is formed of such materials and is not divided similar to the configuration of the present embodiment, the directivity is narrowed, as is clearly understood from the relationship shown in FIG. 2. Therefore, when such materials are used, it is necessary to configure such that the acoustic matching layer **2** is divided in a manner similar to the piezoelectric elements **1**, so that the directivity is increased.

[0103] Moreover, although it has been described for the case where the acoustic matching layer **2** is mainly composed of synthetic rubbers such as chloroprene rubber, ethylene-propylene copolymer rubber, and acrylonitrile-butadiene copolymer rubber, the same advantages can be obtained when the acoustic matching layer **2** is mainly composed of other synthetic rubber materials such as butadiene rubber, isoprene rubber, styrene-butadiene copolymer rubber or acryl rubber.

[0104] Furthermore, although it has been described for the case where the acoustic matching layer **2** is mainly composed of a rubber elastic material such as synthetic rubber, silicon rubber or urethane rubber, the same advantages can be obtained when the acoustic matching layer **2** is formed of other elastomeric materials having a rubber elastic material.

[0105] In addition, although the first embodiment has been described for the case where the piezoelectric elements are arranged in a one-dimensional manner, the same advantages can be obtained when the piezoelectric elements are arranged in a two-dimensional manner. Moreover, although the first embodiment has been described for the case where a plurality of piezoelectric elements is arranged, a rubber elastic material may be used for the acoustic matching layer even when the piezoelectric elements are not arranged but form a single body.

[0106] Furthermore, although the first embodiment has been described for a so-called linear type in which a plurality of piezoelectric elements is arranged in an approximately straight line manner, the same advantages can be obtained for a convex type or a concave type in which a plurality of piezoelectric elements is arranged in a curved surface shape.

#### Embodiment 2

[0107] Hereinafter, an ultrasonic probe according to a second embodiment of the present invention will be described

with reference to the drawings. FIG. 3 is a partially schematic perspective view of an ultrasonic probe 10 according to the second embodiment.

[0108] The ultrasonic probe 10 is configured to include a plurality of piezoelectric elements 1, a two-layered acoustic matching layer 2 (2a and 2b) provided on a front surface in the thickness direction at a subject side (upper side in the drawing) so as to correspond to the respective piezoelectric elements 1, a backing load member 3 provided, as necessary, on a rear surface (lower surface in the drawing) in the thickness direction of the piezoelectric elements 1 at a side opposite to the acoustic matching layer 2 (2a and 2b), and an acoustic lens 4 provided, as necessary, on the acoustic matching layer 2 (2a and 2b). The respective functions of the above-mentioned components are the same as those of the components described in the prior art.

[0109] A ground electrode 5 and a signal electrode 6 are provided on the front surface and the rear surface in the thickness direction Z of the piezoelectric elements 1, respectively. The electrodes 5 and 6 are formed on the front surface and the rear surface of the piezoelectric elements 1, respectively, by means of deposition or sputtering of gold and silver or silver printing.

[0110] The electrodes 5 and 6 are electrically connected to an unillustrated ultrasonic diagnostic apparatus through a cable via an electric terminal 7, so that a regular pulse voltage generated by the ultrasonic probe is applied to the piezoelectric elements 1, and an echo reception signal converted into an electric signal by the piezoelectric elements 1 is transmitted to a body of the ultrasonic diagnostic apparatus.

[0111] In the illustrated example, the piezoelectric elements 1 and a first acoustic matching layer 2a disposed close to the piezoelectric elements 1 are divided into individual ones, and materials, such as silicon rubber or urethane rubber, capable of reducing acoustic coupling are filled in portions corresponding to the division grooves. Moreover, a second acoustic matching layer 2b is provided as one sheet of non-divided, continuous film on an upper surface of the acoustic matching layer 2a disposed close to the piezoelectric elements 1. In addition, an acoustic lens is provided as necessary by using materials such as silicon rubber.

[0112] In the ultrasonic probe 10 of a so-called electronic scanning type, having the plurality of piezoelectric elements 1 arranged therein, similar to the first embodiment, an important point in increasing the resolution of an ultrasonic image is how the directivity in the X direction of the piezoelectric elements 1 can be increased.

[0113] Although the first embodiment has been described for the case where the acoustic matching layer 2 has a single layer, when a difference between respective acoustic impedance of the piezoelectric elements 1 and a subject is large, for example, when PZT-based piezoelectric ceramic materials having an acoustic impedance of about 30 MRayls are used for the piezoelectric elements, the difference is large because the subject has an acoustic impedance of about 1.5 MRayls; therefore, there is a limit in increasing the frequency bandwidth in such a single-layer acoustic matching layer. Therefore, it is necessary to configure the acoustic matching layer 2 to have two or more layers in order to increase the bandwidth.

[0114] However, when the acoustic matching layer is configured to have two or more layers, it was difficult to increase the directivity unless the acoustic matching layer 2 is divided in a manner similar to the piezoelectric elements 1. This is because the acoustic matching layer 2 is divided by a slicing

machine or the like in a manner similar to the piezoelectric elements 1, the thickness increases as the number of layers of the acoustic matching layer 2 increases, and because the number of materials of the layers to be divided increases, the division process is complicated, and thus, it is difficult to perform the division processing in a uniform and stable manner. The present embodiment relates to a configuration that solves such a problem to thereby increase the directivity.

[0115] In the present embodiment, the acoustic matching layer is configured to have two or more layers (in the illustrated example, two layers), and as illustrated in FIG. 3, the piezoelectric elements 1 and the acoustic matching layer 2a disposed close to the piezoelectric elements 1 are divided, and a continuous single-layered acoustic matching layer 2b is provided on an upper surface of the acoustic matching layer 2a.

[0116] As materials of the piezoelectric elements 1, PZT-based piezoelectric ceramic materials, PZN-PT-based or PMN-PT-based single-crystal piezoelectric materials, or a piezoelectric composite made of the materials and polymers are used. As materials of the acoustic matching layer 2a, graphite or epoxy resin in which fillers such as metal or oxides are filled is used.

[0117] Moreover, as materials of the acoustic matching layer 2b, materials mainly composed of the same rubber elastic material as described in the first embodiment, such as silicon rubber, chloroprene rubber, ethylene-propylene copolymer rubber, acrylonitrile-butadiene copolymer rubber, and urethane rubber are used.

[0118] When it is desired to make the acoustic matching layer 2b have an acoustic impedance having a value different from that of the first embodiment, the acoustic impedance can be adjusted by filling fillers such as metal or oxides in a main component material of the rubber elastic material.

[0119] Here, the premise in providing the acoustic matching layer 2b as one sheet of non-divided and continuous film is to select a rubber elastic material capable of providing directivity characteristics equal to or better than those of the configuration where the acoustic matching layer 2b is divided and having an acoustic velocity of 1650 m/sec or less. This can be clearly understood from the result illustrated in FIG. 2 and described in the first embodiment.

[0120] In this way, it is possible to decrease the number of layers of the acoustic matching layer which is to be divided in a manner similar to the piezoelectric elements 1. Therefore, even when they are divided into narrow intervals (for example, 0.1 mm), the processing can be performed in a stable manner, and thus, it is possible to fabricate the ultrasonic probe in a uniform and precise manner without decreasing the directivity.

[0121] As described above, in the configuration where the acoustic matching layer 2a of the two-layered acoustic matching layer 2 disposed close to the piezoelectric elements 1 is divided in a manner similar to the piezoelectric elements 1, and the continuous, single-layered acoustic matching layer 2b is provided on the upper surface of the acoustic matching layer 2a, it is necessary to focus on the acoustic velocity of the material of the acoustic matching layer 2b in order to secure or increase the directivity.

[0122] For example, the materials of the acoustic matching layer 2b are not limited to the rubber elastic materials but plastic materials are also usable. For example, materials in which filling materials are filled in polyethylene resin, polystyrene resin, polyimide resin, epoxy resin, or a material in

which filling materials are filled in the epoxy resin described in Patent Document 2 may be used, and such materials have an acoustic velocity of about 1800 m/sec or more. When the acoustic matching layer 2 is formed of such materials and is not divided similar to the configuration of the present embodiment, the directivity angle is narrowed, as is clearly understood from the result shown in FIG. 2. Therefore, when such materials are used, it is necessary to divide the acoustic matching layer 2b in a manner similar to the piezoelectric elements 1 and the acoustic matching layer 2a.

[0123] Moreover, although the second embodiment has been described for the case where the acoustic matching layer 2b is formed of synthetic rubbers such as chloroprene rubber, ethylene-propylene copolymer rubber, and acrylonitrile-butadiene copolymer rubber, the same advantages can be obtained when the acoustic matching layer 2b is mainly composed of other synthetic rubber materials such as butadiene rubber, isoprene rubber, styrene-butadiene copolymer rubber or acryl rubber.

[0124] Furthermore, although the second embodiment has been described for the case where the acoustic matching layer 2b is formed of a rubber elastic material such as synthetic rubber, silicon rubber or urethane rubber, the same advantages can be obtained when the acoustic matching layer 2b is formed of other elastomeric materials having a rubber elastic material.

[0125] Furthermore, although the second embodiment has been described for the case where the acoustic matching layer 2 has two layers, the same advantages can be obtained when the acoustic matching layer has three or more layers, and an acoustic matching layer disposed close to the subject is not divided but formed as a continuous body by using a rubber elastic material.

[0126] In addition, although the second embodiment has been described for the case where the piezoelectric elements are arranged in a one-dimensional manner, the same advantages can be obtained when the piezoelectric elements are arranged in a two-dimensional manner. Moreover, although the second embodiment has been described for the case where a plurality of piezoelectric elements is arranged, a rubber elastic material may be used for the acoustic matching layer even when the piezoelectric elements are not arranged but form a single body.

[0127] Furthermore, although the second embodiment has been described for a so-called linear type in which a plurality of piezoelectric elements is arranged in an approximately straight line manner, the same advantages can be obtained for a convex type or a concave type in which a plurality of piezoelectric elements is arranged in a curved surface shape.

### Embodiment 3

[0128] Hereinafter, an ultrasonic probe according to a third embodiment of the present invention will be described with reference to the drawings. FIG. 4 is a partially schematic perspective view of an ultrasonic probe 10 according to the third embodiment.

[0129] The ultrasonic probe 10 is configured to include a plurality of piezoelectric elements 1, a three-layered acoustic matching layer 2 (2a, 2b and 2c) provided on a front surface in the thickness direction at a subject side (upper side in the drawing) so as to correspond to the respective piezoelectric elements 1, a backing load member 3 provided, as necessary, on a rear surface (lower surface in the drawing) in the thickness direction of the piezoelectric elements 1 at a side oppo-

site to the acoustic matching layer 2 (2a, 2b and 2c), and an acoustic lens 4 provided, as necessary, on the acoustic matching layer 2 (2a, 2b and 2c). The respective functions of the above-mentioned components are the same as those of the components described in the prior art.

[0130] A ground electrode 5 and a signal electrode 6 are provided on the front surface and the rear surface in the thickness direction Z of the piezoelectric elements 1, respectively. The electrodes 5 and 6 are formed on the front surface and the rear surface of the piezoelectric elements 1, respectively, by means of deposition or sputtering of gold and silver or silver printing.

[0131] The electrodes 5 and 6 are electrically connected to an unillustrated ultrasonic diagnostic apparatus through a cable via an electric terminal 7, so that a regular pulse voltage generated by the ultrasonic probe is applied to the piezoelectric elements 1, and an echo reception signal converted into an electric signal by the piezoelectric elements 1 is transmitted to a body of the ultrasonic diagnostic apparatus.

[0132] In the illustrated example, the piezoelectric elements 1, a first acoustic matching layer 2a, and a second acoustic matching layer 2b, each layer being disposed close to the piezoelectric elements 1 are divided into individual ones, and materials, such as silicon rubber or urethane rubber, capable of reducing acoustic coupling are filled in portions corresponding to the division grooves. Moreover, a third acoustic matching layer 2c is provided as one sheet of non-divided, continuous film on an upper surface of the second acoustic matching layer 2b. In addition, an acoustic lens is provided as necessary by using materials such as silicon rubber.

[0133] In the ultrasonic probe 10 of a so-called electronic scanning type, having the plurality of piezoelectric elements 1 arranged therein, similar to the second embodiment, an important point in increasing the resolution of an ultrasonic image is how the directivity in the X direction of the piezoelectric elements 1 can be increased.

[0134] While the second embodiment has been described for the case where the acoustic matching layer 2 has two layers, since the acoustic matching layer 2 is configured to have three layers, it is possible to further increase the bandwidth. However, when the acoustic matching layer is configured to have three or more layers, as described in Patent Documents 1 and 2, it was difficult to increase the directivity unless the acoustic matching layer 2 (2a, 2b and 2c) is divided in a manner similar to the piezoelectric elements 1.

[0135] This is because the acoustic matching layer 2 is divided by a slicing machine or the like in a manner similar to the piezoelectric elements 1, the thickness increases as the number of layers of the acoustic matching layer 2 increases, and because the number of materials of the layers to be divided increases, the division process is complicated, and thus, it is difficult to perform the division processing in a uniform and stable manner. The present embodiment relates to a configuration that solves such a problem to thereby provide a broader bandwidth and increase the directivity.

[0136] In the present embodiment, the acoustic matching layer is configured to have three layers, and as illustrated in FIG. 4, the piezoelectric elements 1 and the first and second acoustic matching layers 2a and 2b disposed close to the piezoelectric elements 1 are divided, and a third continuous single-layered acoustic matching layer 2c is provided on an upper surface of the first acoustic matching layer 2a and the second acoustic matching layer 2b.

[0137] As materials of the piezoelectric elements **1**, PZT-based piezoelectric ceramic materials, PZN-PT-based or PMN-PT-based single-crystal piezoelectric materials, or a piezoelectric composite made of the materials and polymers are used. As materials of the first acoustic matching layer **2a**, materials such as glass, such as single-crystal silicon, crystal or molten quartz, machinable ceramics, or graphite, having an acoustic impedance value ranging from 8 to 20 MRayls are used. As materials of the second acoustic matching layer **2b**, materials such as graphite or epoxy resin in which fillers such as metal or oxides are filled, having an acoustic impedance value ranging from 3 to 8 MRayls are used.

[0138] Moreover, as materials of the third acoustic matching layer **2c**, materials mainly composed of a rubber elastic material, such as silicon rubber, chloroprene rubber, ethylene-propylene copolymer rubber, acrylonitrile-butadiene copolymer rubber, and urethane rubber are used.

[0139] The respective acoustic impedances of the acoustic matching layer **2** (**2a**, **2b** and **2c**) are determined by the respective materials or frequency characteristics thereof. For example, the frequency characteristics were calculated in a configuration where the frequency was set to a central frequency of 3.5 MHz, a material having an acoustic impedance of 7 MRayls was used for the backing load member **3**, a PZT-based piezoelectric ceramic material such as PZT-5H was used for the piezoelectric elements **1**, graphite having an acoustic impedance of 9 MRayls was used for the first acoustic matching layer **2a**, and epoxy resin in which oxides having an acoustic impedance of 4 MRayls are filled was used for the second acoustic matching layer **2b**, so that the acoustic impedance of the third acoustic matching layer **2c** is varied in the range of 1.5 to 2.5 MRayls.

[0140] The relationship between a fractional bandwidth of the frequency characteristics at -6 dB and a pulse length, evaluated at levels of -6 dB, -20 dB, and -40 dB is illustrated in FIG. 5. In FIG. 5, a horizontal axis represents an acoustic impedance of the third acoustic matching layer **2c**, the left vertical axis represents a pulse length, and the right vertical axis represents a fractional frequency bandwidth (bandwidth/central frequency) at -6 dB.

[0141] As will be clearly understood from FIG. 5, the pulse length is scarcely changed at a level of -6 dB when the acoustic impedance of the third acoustic matching layer **2c** varies; however, the pulse length is changed at levels of -20 dB and -40 dB and has a small value when the acoustic impedance is in the range of 1.8 to 2.3 MRayls. Since the resolution increases advantageously as the pulse length has smaller values, decreasing the pulse width is important in increasing the resolution.

[0142] On the other hand, as the fractional bandwidth increases, a resolution and a diagnostic depth increase. Looking into the fractional frequency bandwidth illustrated in FIG. 5, it can be known that when the acoustic impedance of the third acoustic matching layer **2c** increases greater than about 2.3 MRayls, the fractional bandwidth becomes 80 percents or less, and it is thus difficult to provide a broader bandwidth. Therefore, from the result of the characteristics of the pulse length and the fractional bandwidth, it can be concluded that the acoustic impedance of the third acoustic matching layer **2c** is preferably in the range of 1.8 to 2.2 MRayls.

[0143] As materials of the third acoustic matching layer **2c** having an acoustic impedance in the range of 1.8 to 2.2 MRayls, a material which can provide the acoustic impedance of that range solely as a main component material of a

rubber elastic material can be used, per se; however, a material having an acoustic impedance value outside that range may be filled with fillers or the like in order to adjust the acoustic impedance.

[0144] Here, the premise in providing the third acoustic matching layer **2c** as one sheet of non-divided and continuous film is to select a rubber elastic material capable of providing directivity characteristics equal to or better than those of the configuration where the third acoustic matching layer **2c** is divided and having an acoustic velocity of 1650 m/sec or less. This can be clearly understood from the result illustrated in FIG. 2 and described in the first embodiment.

[0145] In this way, it is possible to decrease the number of layers of the acoustic matching layer which is to be divided in a manner similar to the piezoelectric elements **1**. Therefore, even when they are divided into narrow intervals (for example, 0.1 mm), the processing can be performed in a stable manner, and thus, it is possible to fabricate the ultrasonic probe in a uniform and precise manner without decreasing the directivity.

[0146] As described above, in the configuration where the first and second acoustic matching layers **2a** and **2b** of the three-layered acoustic matching layer **2** disposed close to the piezoelectric elements **1** are divided in a manner similar to the piezoelectric elements **1**, and the third continuous, single-layered acoustic matching layer **2c** is provided on the upper surface of the second acoustic matching layer **2b**, it is necessary to focus on the acoustic velocity of the material of the third acoustic matching layer **2c** in order to secure or increase the directivity.

[0147] For example, the materials suitable for the third acoustic matching layer **2c** are not limited to the rubber elastic materials but plastic materials are also usable. For example, materials in which filling materials are filled in polyethylene resin, polystyrene resin, polyimide resin, epoxy resin, or a material in which filling materials are filled in the epoxy resin described in Patent Document 2 may be used, and such materials have an acoustic velocity of about 1800 m/sec or more. When the third acoustic matching layer **2c** is formed of such materials and is not divided similar to the configuration of the present embodiment, the directivity angle is narrowed, as is clearly understood from the result shown in FIG. 2. Therefore, when such materials are used, it is necessary to divide the third acoustic matching layer **2c** in a manner similar to the piezoelectric elements **1** and the first and second acoustic matching layers **2a** and **2b**.

[0148] Moreover, although the third embodiment has been described for the case where the third acoustic matching layer **2c** is formed of synthetic rubbers such as chloroprene rubber, ethylene-propylene copolymer rubber, and acrylonitrile-butadiene copolymer rubber, the same advantages can be obtained when the third acoustic matching layer **2c** is mainly composed of other synthetic rubber materials such as butadiene rubber, isoprene rubber, styrene-butadiene copolymer rubber or acryl rubber.

[0149] Furthermore, although the third embodiment has been described for the case where the third acoustic matching layer **2c** is formed of a rubber elastic material such as synthetic rubber, silicon rubber or urethane rubber, the same advantages can be obtained when the third acoustic matching layer **2c** is formed of other elastomeric materials having a rubber elastic material.

[0150] Furthermore, although the third embodiment has been described for the case where the acoustic matching layer

**2** has three layers, the same advantages can be obtained when the acoustic matching layer has four or more layers, and an acoustic matching layer disposed close to the subject is not divided but formed as a continuous body by using a rubber elastic material.

[0151] In addition, although the third embodiment has been described for the case where the piezoelectric elements are arranged in a one-dimensional manner, the same advantages can be obtained when the piezoelectric elements are arranged in a two-dimensional manner. Moreover, although the third embodiment has been described for the case where a plurality of piezoelectric elements is arranged, the same advantage of the broader bandwidth can be provided when the acoustic matching layer is configured to have three or more layers, and a rubber elastic material is used for the acoustic matching layer disposed close to the subject, even when the piezoelectric elements are not arranged but form a single body.

[0152] Furthermore, although the third embodiment has been described for a so-called linear type in which a plurality of piezoelectric elements is arranged in an approximately straight line manner, the same advantages can be obtained for a convex type or a concave type in which a plurality of piezoelectric elements is arranged in a curved surface shape.

#### Embodiment 4

[0153] Hereinafter, an ultrasonic probe according to a fourth embodiment of the present invention will be described with reference to the drawings. FIG. 6 is a partially schematic perspective view of an ultrasonic probe **10** according to the fourth embodiment.

[0154] The ultrasonic probe **10** is configured to include a plurality of piezoelectric elements **1**, a three-layered acoustic matching layer **2** (**2a**, **2b** and **2c**) provided on a front surface in the thickness direction at a subject side (upper side in the drawing) so as to correspond to the respective piezoelectric elements **1**, a backing load member **3** provided, as necessary, on a rear surface (lower surface in the drawing) in the thickness direction of the piezoelectric elements **1** at a side opposite to the acoustic matching layer **2** (**2a**, **2b** and **2c**), and an acoustic lens **4** provided, as necessary, on the acoustic matching layer **2** (**2a**, **2b** and **2c**). The respective functions of the above-mentioned components are the same as those of the components described in the prior art.

[0155] A ground electrode **5** and a signal electrode **6** are provided on the front surface and the rear surface in the thickness direction *Z* of the piezoelectric elements **1**, respectively. The electrodes **5** and **6** are formed on the front surface and the rear surface of the piezoelectric elements **1**, respectively, by means of deposition or sputtering of gold and silver or silver printing.

[0156] The electrodes **5** and **6** are electrically connected to an unillustrated ultrasonic diagnostic apparatus through a cable via an electric terminal **7**, so that a regular pulse voltage generated by the ultrasonic probe is applied to the piezoelectric elements **1**, and an echo reception signal converted into an electric signal by the piezoelectric elements **1** is transmitted to a body of the ultrasonic diagnostic apparatus.

[0157] In the illustrated example, the piezoelectric elements **1** and a first acoustic matching layer **2a** disposed close to the piezoelectric elements **1** are divided into individual ones, and materials, such as silicon rubber or urethane rubber, capable of reducing acoustic coupling are filled in portions corresponding to the division grooves. Moreover, a second acoustic matching layer **2b** and a third acoustic matching

layer **2c** are provided as a non-divided, continuous film on an upper surface of the first acoustic matching layer **2a**. In addition, an acoustic lens is provided as necessary by using materials such as silicon rubber.

[0158] In the ultrasonic probe **10** of a so-called electronic scanning type, having the plurality of piezoelectric elements **1** arranged therein, similar to the second and third embodiments, an important point in increasing the resolution of an ultrasonic image is how the directivity in the *X* direction of the piezoelectric elements **1** can be increased.

[0159] Although the second embodiment has been described for the case where the acoustic matching layer **2** has two layers, since the acoustic matching layer **2** is configured to have three layers, it is possible to further increase the bandwidth. However, when the acoustic matching layer is configured to have three or more layers, as described in Patent Documents 1 and 2, it was difficult to increase the directivity unless the acoustic matching layer **2** (**2a**, **2b** and **2c**) is divided in a manner similar to the piezoelectric elements **1**.

[0160] This is because the acoustic matching layer **2** is divided by a slicing machine or the like in a manner similar to the piezoelectric elements **1**, the thickness increases as the number of layers of the acoustic matching layer **2** increases, and because the number of materials of the layers to be divided increases, the division process is complicated, and thus, it is difficult to perform the division processing in a uniform and stable manner. The present embodiment relates to a configuration that solves such a problem to thereby provide a broader bandwidth and increase the directivity.

[0161] In the present embodiment, the acoustic matching layer is configured to have three layers, and as illustrated in FIG. 6, the piezoelectric elements **1** and the first acoustic matching layer **2a** disposed close to the piezoelectric elements **1** are divided, and the second and third continuous acoustic matching layers **2b** and **2c** are provided on an upper surface of the first acoustic matching layer **2a**.

[0162] As materials of the piezoelectric elements **1**, PZT-based piezoelectric ceramic materials, PZN-PT-based or PMN-PT-based single-crystal piezoelectric materials, or a piezoelectric composite made of the materials and polymers are used. As materials of the first acoustic matching layer **2a**, materials such as glass including single-crystal silicon, crystal or molten quartz, machinable ceramics, or graphite, having an acoustic impedance value ranging from 8 to 20 MRayls are used. As materials of the second acoustic matching layer **2b**, materials such as a rubber elastic material in which fillers such as metal powder or oxide powder are filled, having an acoustic impedance value ranging from 3 to 8 MRayls are used.

[0163] Moreover, as materials of the third acoustic matching layer **2c**, materials mainly composed of a rubber elastic material, such as silicon rubber, chloroprene rubber, ethylene-propylene copolymer rubber, acrylonitrile-butadiene copolymer rubber, and urethane rubber are used. The present embodiment is characterized in that neither the second acoustic matching layer **2b** nor the third acoustic matching layer **2c** is divided.

[0164] When the second acoustic matching layer **2b** is not divided unlike the piezoelectric elements **1**, the directivity is narrowed as described above and it is thus not desirable. However, even when the second acoustic matching layer is not divided, it does not cause any problem as long as the directivity is not narrowed. Moreover, as described in the

second and third embodiments, the smaller number of constituent components, the easier the division process can be performed.

**[0165]** In order to use the configuration where the second and third acoustic matching layers **2b** and **2c** are not divided, as illustrated in FIG. 2 and described in the third embodiment, when the second acoustic matching layer **2b** is formed of the same rubber elastic material as the third acoustic matching layer **2c** and having an acoustic velocity value of 1650 m/sec or less, it is possible to obtain characteristics that the directivity is not narrowed even when the second acoustic matching layer **2b** is not divided.

**[0166]** As materials of the second acoustic matching layer **2b** having an acoustic impedance in the range of 3 to 8 MRayls and an acoustic velocity of 1650 m/sec or less, a material in which fillers of metal powder (average grain size of 1.2  $\mu\text{m}$ ) are filled in acrylonitrile-butadiene copolymer rubber at a ratio of 9:1 in terms of weight percent, having an acoustic impedance of 5.3 MRayls and an acoustic velocity of 1070 m/sec, which provides desired characteristic values as the second acoustic matching layer **2b** is used.

**[0167]** In this way, by filling fillers having a large density such as oxides or metal powder such as tungsten, silver, iron or nickel in a material mainly composed of synthetic rubber-based elastic materials, it is possible to obtain a material having an acoustic impedance and an acoustic velocity needed by the second acoustic matching layer **2b**.

**[0168]** In this way, it is possible to decrease the number of layers of the acoustic matching layer which is to be divided in a manner similar to the piezoelectric elements **1**. Therefore, even when they are divided into narrow intervals (for example, 0.1 mm), the processing can be performed in a stable manner, and thus, it is possible to fabricate the ultrasonic probe in a uniform and precise manner without decreasing the directivity.

**[0169]** Moreover, the fourth embodiment has been described for the case where a material in which fillers of copper powder are filled in the acrylonitrile-butadiene copolymer rubber, which is synthetic rubber, is used for the second acoustic matching layer **2b**, the same advantages can be obtained when a material composed of other fillers and synthetic material, such as chloroprene rubber, ethylene-propylene copolymer rubber, butadiene rubber, isoprene rubber, styrene-butadiene copolymer rubber or acryl rubber, silicon rubber, urethane rubber, or elastomeric materials is used.

**[0170]** Furthermore, although the fourth embodiment has been described for the case where the acoustic matching layer **2** has three layers, the same advantages can be obtained when the acoustic matching layer has four or more layers, and an acoustic matching layer disposed close to the subject is not divided but formed as a continuous body by using a rubber elastic material.

**[0171]** In addition, although the fourth embodiment has been described for the case where the piezoelectric elements are arranged in a one-dimensional manner, the same advantages can be obtained when the piezoelectric elements are arranged in a two-dimensional manner. Moreover, although the fourth embodiment has been described for the case where a plurality of piezoelectric elements is arranged, the same advantage of the broader bandwidth can be provided when the acoustic matching layer is configured to have three or more layers, and a rubber elastic material is used for the acoustic

matching layer disposed close to the subject, even when the piezoelectric elements are not arranged but form a single body.

**[0172]** Furthermore, although the fourth embodiment has been described for a so-called linear type in which a plurality of piezoelectric elements is arranged in an approximately straight line manner, the same advantages can be obtained for a convex type or a concave type in which a plurality of piezoelectric elements is arranged in a curved surface shape.

#### Embodiment 5

**[0173]** Hereinafter, an ultrasonic probe according to a fifth embodiment of the present invention will be described with reference to the drawings. FIG. 7 is a partially schematic perspective view of an ultrasonic probe **10** according to the fifth embodiment.

**[0174]** The ultrasonic probe **10** is configured to include a plurality of piezoelectric elements **1**, a four-layered acoustic matching layer **2** (**2a**, **2b**, **2c** and **2d**) provided on a front surface in the thickness direction at a subject side (upper side in the drawing) so as to correspond to the respective piezoelectric elements **1**, a backing load member **3** provided, as necessary, on a rear surface (lower surface in the drawing) in the thickness direction of the piezoelectric elements **1** at a side opposite to the acoustic matching layer **2** (**2a**, **2b**, **2c** and **2d**), and an acoustic lens **4** provided, as necessary, on the acoustic matching layer **2** (**2a**, **2b**, **2c** and **2d**). The respective functions of the above-mentioned components are the same as those of the components described in the prior art.

**[0175]** A ground electrode **5** and a signal electrode **6** are provided on the front surface and the rear surface in the thickness direction *Z* of the piezoelectric elements **1**, respectively. The electrodes **5** and **6** are formed on the front surface and the rear surface of the piezoelectric elements **1**, respectively, by means of deposition or sputtering of gold and silver or silver printing.

**[0176]** The electrodes **5** and **6** are electrically connected to an unillustrated ultrasonic diagnostic apparatus through a cable via an electric terminal **7**, so that a regular pulse voltage generated by the ultrasonic probe is applied to the piezoelectric elements **1**, and an echo reception signal converted into an electric signal by the piezoelectric elements **1** is transmitted to a body of the ultrasonic diagnostic apparatus.

**[0177]** In the illustrated example, the piezoelectric elements **1**, and acoustic matching layers **2a**, **2b** and **2c** disposed close to the piezoelectric elements **1** are divided into individual ones, and materials, such as silicon rubber or urethane rubber, capable of reducing acoustic coupling are filled in portions corresponding to the division grooves. Moreover, another acoustic matching layer **2d** is provided as one sheet of non-divided, continuous film on an upper surface of the acoustic matching layer **2c**. In addition, an acoustic lens is provided as necessary by using materials such as silicon rubber.

**[0178]** In the ultrasonic probe **10** of a so-called electronic scanning type, having the plurality of piezoelectric elements **1** arranged therein, an important point in increasing the resolution of an ultrasonic image is how the directivity in the arrangement direction of the piezoelectric elements **1** can be increased.

**[0179]** Since the acoustic matching layer **2** provided on the subject side of the piezoelectric elements **1** is configured to have a plurality of layers, it is possible to increase the bandwidth. However, when the acoustic matching layer is config-

ured to have four or more layers, as illustrated in FIG. 12 (see Patent Documents 1 and 2), it was difficult to increase the directivity unless the three-layered acoustic matching layer 12 is divided in a manner similar to the piezoelectric elements 12.

[0180] This is because the acoustic matching layer 12 is divided by a slicing machine or the like in a manner similar to the piezoelectric elements 11, the thickness increases as the number of layers of the acoustic matching layer 12 is further increased, and because the number of materials of the layers to be divided increases, the division process is complicated, and thus, it is difficult to perform the division processing in a uniform and stable manner. The present embodiment relates to a configuration that solves such a problem to thereby provide a broader bandwidth and increase the directivity.

[0181] In the present embodiment, the acoustic matching layer is configured to have four layers, and as illustrated in FIG. 7, the piezoelectric elements 1 and first, second and third acoustic matching layers 2a, 2b and 2c disposed close to the piezoelectric elements 1 are divided, and a fourth continuous single-layered acoustic matching layer 2d is additionally provided on an upper surface of the third acoustic matching layer 2c.

[0182] As materials of the piezoelectric elements 1, PZT-based piezoelectric ceramic materials, PZN-PT-based or PMN-PT-based single-crystal piezoelectric materials, or a piezoelectric composite made of the materials and polymers are used. As materials of the first acoustic matching layer 2a, materials such as single-crystal silicon, crystal, tellurite glass, machinable ceramics, having an acoustic impedance smaller than that of the piezoelectric elements 1 are used. As materials of the second acoustic matching layer 2b, materials such as glass-based material typified by molten quartz, graphite or epoxy resin in which fillers such as metal or oxides are filled, having an acoustic impedance smaller than that of the first acoustic matching layer 2a are used. As materials of the third acoustic matching layer 2c, materials such as graphite or epoxy resin in which fillers such as metal or oxides are filled, having an acoustic impedance smaller than that of the second acoustic matching layer 2b are used.

[0183] Moreover, as materials of the fourth acoustic matching layer 2d, materials mainly composed of a rubber elastic material, such as silicon rubber, chloroprene rubber, ethylene-propylene copolymer rubber, acrylonitrile-butadiene copolymer rubber, and polyurethane rubber, having an acoustic impedance smaller than that of the third acoustic matching layer 2c are used. As is known, the respective acoustic matching layers 2 (2a, 2b, 2c and 2d) basically have a thickness basically corresponding to a  $\frac{1}{4}$  wavelength of a using frequency.

[0184] The present embodiment is characterized in that the piezoelectric elements 1 and the first, second and third acoustic matching layers 2 (2a, 2b and 2c) are divided, and the fourth acoustic matching layer 2d of rubber elastic materials is provided on the upper surface of the third acoustic matching layer 2c in a one-layer state where the acoustic matching layer is not divided but connected, so that it is easy to process and the processing can be performed in a uniform and stable manner. The present embodiment is also characterized in that the resulting directivity is equal to or greater than that obtainable from the configuration where the division is performed up to the fourth acoustic matching layer 2d.

[0185] In order to obtain broader directivity with a configuration where the acoustic matching layer is not divided, as

illustrated in FIG. 2 and described in the first embodiment, it is necessary to form the acoustic matching layer using a rubber elastic material having an acoustic velocity of 1650 m/sec or less. Therefore, materials having such characteristics are used for the fourth acoustic matching layer.

[0186] Moreover, although it has been described for the case where the fourth acoustic matching layer 2d is mainly composed of synthetic rubbers such as chloroprene rubber, ethylene-propylene copolymer rubber, and acrylonitrile-butadiene copolymer rubber, the same advantages can be obtained when the fourth acoustic matching layer 2d is mainly composed of other synthetic rubber materials such as butadiene rubber, isoprene rubber, styrene-butadiene copolymer rubber or acryl rubber.

[0187] Furthermore, although it has been described for the case where the fourth acoustic matching layer 2d is mainly composed of a rubber elastic material such as synthetic rubber, silicon rubber or urethane rubber, the same advantages can be obtained when the fourth acoustic matching layer 2d is formed of other elastomeric materials having a rubber elastic material.

[0188] In addition, although the fifth embodiment has been described for the case where the piezoelectric elements are arranged in a one-dimensional manner, the same advantages can be obtained when the piezoelectric elements are arranged in a two-dimensional manner. Moreover, although the fifth embodiment has been described for the case where a plurality of piezoelectric elements is arranged, the same advantage of the broader bandwidth can be provided when the acoustic matching layer is configured to have three or more layers, and a rubber elastic material is used for the acoustic matching layer disposed close to the subject, even when the piezoelectric elements are not arranged but form a single body.

[0189] Furthermore, although the fifth embodiment has been described for a so-called linear type in which a plurality of piezoelectric elements are arranged in an approximately straight line manner, the same advantages can be obtained for a convex type or a concave type in which a plurality of piezoelectric elements are arranged in a curved surface shape.

[0190] According to the configuration described above, since the acoustic velocity is defined by the rubber elastic material as the material of the fourth acoustic matching layer disposed on the subject side of the acoustic matching layer and the fourth acoustic matching layer is not divided, it is possible to provide broader frequency bandwidth and increase the directivity. Moreover, since it is not necessary to process and divide the fourth acoustic matching layer together with the piezoelectric elements, it is possible to eliminate difficulties in processing and provide a stable ultrasonic probe. Accordingly, phase control can be freely performed by using a greater number of piezoelectric elements, and thus an ultrasonic beam can be condensed narrow. Furthermore, since the ultrasonic beam can be deflected, it is possible to provide an ultrasonic probe capable providing a high-resolution ultrasonic image.

#### Embodiment 6

[0191] Hereinafter, an ultrasonic probe according to a sixth embodiment of the present invention will be described with reference to the drawings. FIG. 8 is a partially schematic perspective view of an ultrasonic probe 10 according to the sixth embodiment.

[0192] The ultrasonic probe 10 is configured to include a plurality of piezoelectric elements 1, a four-layered acoustic

matching layer **2** (**2a**, **2b**, **2c** and **2d**) provided on a front surface in the thickness direction at a subject side (upper side in the drawing) so as to correspond to the respective piezoelectric elements **1**, a backing load member **3** provided, as necessary, on a rear surface (lower surface in the drawing) in the thickness direction of the piezoelectric elements **1** at a side opposite to the acoustic matching layer **2** (**2a**, **2b**, **2c** and **2d**), and an acoustic lens **4** provided, as necessary, on the acoustic matching layer **2** (**2a**, **2b**, **2c** and **2d**). The respective functions of the above-mentioned components are the same as those of the components described in the prior art.

**[0193]** A ground electrode **5** and a signal electrode **6** are provided on the front surface and the rear surface in the thickness direction *Z* of the piezoelectric elements **1**, respectively. The electrodes **5** and **6** are formed on the front surface and the rear surface of the piezoelectric elements **1**, respectively, by means of deposition or sputtering of gold and silver or silver printing.

**[0194]** The electrodes **5** and **6** are electrically connected to an unillustrated ultrasonic diagnostic apparatus through a cable via an electric terminal **7**, so that a regular pulse voltage generated by the ultrasonic probe is applied to the piezoelectric elements **1**, and an echo reception signal converted into an electric signal by the piezoelectric elements **1** is transmitted to a body of the ultrasonic diagnostic apparatus.

**[0195]** In the illustrated example, the piezoelectric elements **1** and first and second acoustic matching layers **2a** and **2b** disposed close to the piezoelectric elements **1** are divided into individual ones, and materials, such as silicon rubber or urethane rubber, capable of reducing acoustic coupling are filled in portions corresponding to the division grooves.

**[0196]** Moreover, a third acoustic matching layer **2c** and a fourth acoustic matching layer **2d** are provided as a non-divided, continuous film on an upper surface of the second acoustic matching layer **2b**. In addition, an acoustic lens is provided as necessary by using materials such as silicon rubber.

**[0197]** In the ultrasonic probe **10** of a so-called electronic scanning type, having the plurality of piezoelectric elements **1** arranged therein, similar to the first embodiment, an important point in increasing the resolution of an ultrasonic image is how the directivity in the *X* direction of the piezoelectric elements **1** can be increased.

**[0198]** In the present embodiment, the acoustic matching layer is configured to have four layers, and as illustrated in FIG. **8**, the piezoelectric elements **1** and the first and second acoustic matching layers **2a** and **2b** disposed close to the piezoelectric elements **1** are divided, the third continuous acoustic matching layer **2c** is provided on an upper surface of the second acoustic matching layer **2b**, and the fourth continuous acoustic matching layer **2d** is provided on an upper surface of the third acoustic matching layer **2c**.

**[0199]** As materials of the piezoelectric elements **1**, PZT-based piezoelectric ceramic materials, PZN-PT-based or PMN-PT-based single-crystal piezoelectric materials, or a piezoelectric composite made of the materials and polymers are used. As materials of the first acoustic matching layer **2a**, materials such as single-crystal silicon, crystal, tellurite glass, machinable ceramics, having an acoustic impedance smaller than that of the piezoelectric elements **1** are used. As materials of the second acoustic matching layer **2b**, materials such as glass-based material typified by molten quartz, graphite or epoxy resin in which fillers such as metal or oxides are filled, having an acoustic impedance smaller than that of the first

acoustic matching layer **2a** are used. As materials of the third acoustic matching layer **2c**, rubber elastic materials having an acoustic impedance smaller than that of the second acoustic matching layer **2b** and an acoustic velocity of 1650 m/sec or less are used.

**[0200]** Moreover, as materials of the fourth acoustic matching layer **2d**, materials mainly composed of a rubber elastic material, such as silicon rubber, chloroprene rubber, ethylene-propylene copolymer rubber, acrylonitrile-butadiene copolymer rubber, and urethane rubber, having an acoustic impedance smaller than that of the third acoustic matching layer **2c** are used. As is known, the respective acoustic matching layers **2** (**2a**, **2b**, **2c** and **2d**) basically have a thickness basically corresponding to a  $\frac{1}{4}$  wavelength of a using frequency.

**[0201]** The present embodiment is characterized in that the piezoelectric elements **1** and the first and second acoustic matching layers **2** (**2a** and **2b**) are divided, and the third acoustic matching layer **2c** of rubber elastic materials is provided on the upper surface of the second acoustic matching layer **2b** in a one-layer state where the acoustic matching layer is not divided but connected, and moreover, the fourth acoustic matching layer **2d** is provided on the upper surface of the third acoustic matching layer in a one-layer state where it is not divided but connected in a manner similar to the third acoustic matching layer **2c**, so that it is easy to process and the processing can be performed in a uniform and stable manner. The present embodiment is also characterized in that the resulting directivity is equal to or greater than that obtainable from the configuration where the division is performed up to the third and fourth acoustic matching layers **2c** and **2d**.

**[0202]** When the third acoustic matching layer **2c** is not divided unlike the piezoelectric elements **1**, the directivity is narrowed as described above and it is thus not desirable. However, even when the second acoustic matching layer is not divided, it does not cause any problem as long as the directivity is not narrowed. Moreover, as described in the first embodiment, the smaller number of constituent components, the easier the division process can be performed.

**[0203]** In order to use the configuration where the third and fourth acoustic matching layers **2c** and **2d** are not divided, as illustrated in FIG. **2** and described in the first embodiment, when the third acoustic matching layer **2c** is formed of the same rubber elastic material as the fourth acoustic matching layer **2d** and having an acoustic velocity of 1650 m/sec or less, it is possible to obtain characteristics that the directivity is not narrowed even when the third acoustic matching layer **2c** is not divided.

**[0204]** As materials of the third acoustic matching layer **2c** having an acoustic impedance intermediate between those of the second and fourth acoustic matching layers **2b** and **2d** and an acoustic velocity of 1650 m/sec or less, a material in which fillers of metal powder (average grain size of 1.2  $\mu\text{m}$ ) are filled in acrylonitrile-butadiene copolymer rubber at a ratio of 9:1 in terms of weight percent, having an acoustic impedance of 5.3 MRayls and an acoustic velocity of 1070 m/sec, which provides desired characteristics as the third acoustic matching layer **2c** is used.

**[0205]** In this way, by filling fillers having a large density such as oxides or metal powder such as tungsten, silver, iron or nickel in a material mainly composed of synthetic rubber-based elastic materials, it is possible to obtain a material having an acoustic impedance and an acoustic velocity needed by the third acoustic matching layer **2c**.

[0206] In this way, it is possible to decrease the number of layers of the acoustic matching layer which is to be divided in a manner similar to the piezoelectric elements 1. Therefore, even when they are divided into narrow intervals (for example, 0.1 mm), the processing can be performed in a stable manner, and thus, it is possible to fabricate the ultrasonic probe in a uniform and precise manner without decreasing the directivity.

[0207] Moreover, the sixth embodiment has been described for the case where a material in which fillers of copper powder are filled in the acrylonitrile-butadiene copolymer rubber, which is synthetic rubber, is used for the third acoustic matching layer 2c, the same advantages can be obtained when a material composed of other fillers and synthetic material, such as chloroprene rubber, ethylene-propylene copolymer rubber, butadiene rubber, isoprene rubber, styrene-butadiene copolymer rubber or acryl rubber, silicon rubber, urethane rubber, or elastomeric materials is used.

[0208] Furthermore, although the sixth embodiment has been described for the case where the acoustic matching layer 2 has four layers, the same advantages can be obtained when the acoustic matching layer has two layers or five or more layers, and an acoustic matching layer disposed close to the subject is not divided but formed as a continuous body by using a rubber elastic material.

[0209] In addition, although the sixth embodiment has been described for the case where the piezoelectric elements are arranged in a one-dimensional manner, the same advantages can be obtained when the piezoelectric elements are arranged in a two-dimensional manner. Moreover, although the sixth embodiment has been described for the case where a plurality of piezoelectric elements are arranged, the same advantage of the broader bandwidth can be provided when the acoustic matching layer is configured to have three or more layers, and a rubber elastic material is used for the acoustic matching layer disposed close to the subject, even when the piezoelectric elements are not arranged but form a single body.

[0210] Furthermore, although the sixth embodiment has been described for a so-called linear type in which a plurality of piezoelectric elements is arranged in an approximately straight line manner, the same advantages can be obtained for a convex type or a concave type in which a plurality of piezoelectric elements is arranged in a curved surface shape.

#### Embodiment 7

[0211] Hereinafter, an ultrasonic probe according to a seventh embodiment of the present invention will be described with reference to the drawings. FIG. 9A is a partially schematic perspective view of an ultrasonic probe 10 according to the seventh embodiment, and FIG. 9B is a schematic sectional view as viewed from the X direction in FIG. 9A.

[0212] The ultrasonic probe 10 is configured to include a plurality of piezoelectric elements 1, a three-layered acoustic matching layer 2 (2a, 2b and 2c) provided on a front surface in the thickness direction at a subject side (upper side in the drawing) so as to correspond to the respective piezoelectric elements 1, a backing load member 3 provided, as necessary, on a rear surface (lower surface in the drawing) in the thickness direction of the piezoelectric elements 1 at a side opposite to the acoustic matching layer 2 (2a, 2b and 2c), and an acoustic lens 4 provided, as necessary, on the acoustic matching layer 2 (2a, 2b and 2c). The respective functions of the above-mentioned components are the same as those of the components described in the prior art.

[0213] A ground electrode 5 and a signal electrode 6 are provided on the front surface and the rear surface in the thickness direction Z of the piezoelectric elements 1, respectively. The electrodes 5 and 6 are formed on the front surface and the rear surface of the piezoelectric elements 1, respectively, by means of deposition or sputtering of gold and silver or silver printing.

[0214] Further detailed description will be provided below. Between the signal electrode 6 provided on the piezoelectric elements 1 made of materials such as PZT-based piezoelectric ceramic materials, PZN-PT-based or PMN-PT-based single-crystal piezoelectric materials, or a piezoelectric composite composed of the materials and polymers, and the backing load member 3, a film 8 (first polymer film), in which a metal film of copper or the like is provided on a polymer film of polyimide or the like, is provided, the electric terminal 7 of the metal film of the film 8 is in contact with the signal electrode 6, and the polymer film is in contact with the backing load member 3.

[0215] Meanwhile, on the side of the ground electrode 5 provided on the surface of the piezoelectric elements 1, a first acoustic matching layer 2a, which is a conductor such as graphite (if it is an insulating material, the insulator is plated with metal to form a conductor). Moreover, a film 9 (second polymer film), in which a metal film of copper (having a thickness of 5  $\mu\text{m}$  or less so that the characteristics are not influenced greatly) is provided on a polymer film of polyimide or the like, is provided on an upper surface of the first acoustic matching layer 2a, and the first acoustic matching layer 2a, which is a conductor, and the film 9 are in contact with each other.

[0216] Further, a second acoustic matching layer 2b formed of materials, such as graphite or epoxy resin in which fillers such as metal or oxides are filled, is provided on an upper surface of the polymer film of the film 9. Moreover, when the first acoustic matching layer 2a is formed of an insulating material, since a conductor can be formed by means of plating the entire surroundings of the insulator, it is not always necessary to form the first acoustic matching layer 2a using a conductor. Furthermore, it does not matter whether the second acoustic matching layer 2b is formed of an insulator or a conductor.

[0217] After the configuration described above is formed, a portion of the backing load member 3, the film 8, the piezoelectric elements 1, the first acoustic matching layer 2a, the film 9, and the second acoustic matching layer 2b are processed and divided by means of a slicing machine or the like. In portions corresponding to the division grooves, materials such as silicon rubber or urethane rubber, capable of reducing acoustic coupling are filled, and a third acoustic matching layer 2c is provided on an upper surface of the second acoustic matching layer 2b and the filled portions of the division grooves.

[0218] The third acoustic matching layer 2c is provided in a state where it is not divided but connected, as illustrated in the drawing. Moreover, as materials of the third acoustic matching layer 2c, materials mainly composed of a rubber elastic material, such as silicon rubber, chloroprene rubber, ethylene-propylene copolymer rubber, acrylonitrile-butadiene copolymer rubber, and urethane rubber are used. Furthermore, an acoustic lens 4 formed of materials such as silicon rubber is provided, as necessary, on an upper surface of the third acoustic matching layer 2c.

[0219] The signal electrode 6 is electrically connected to an unillustrated ultrasonic diagnostic apparatus through a cable via the metal film of the electric terminal 7 of the film 8, and the ground electrode 5 is electrically connected to the ultrasonic diagnostic apparatus through a cable via the first acoustic matching layer 2a and the conductor of the metal film of the film 9, so that a regular pulse voltage generated by the ultrasonic probe is applied to the piezoelectric elements 1, and an echo reception signal converted into an electric signal by the piezoelectric elements 1 is transmitted to a body of the ultrasonic diagnostic apparatus.

[0220] In the ultrasonic probe 10 of a so-called electronic scanning type, having the plurality of piezoelectric elements 1 arranged therein, an important point in increasing the resolution of an ultrasonic image is how the directivity in the arrangement direction of the piezoelectric elements 1 can be increased.

[0221] Meanwhile, since the piezoelectric elements 1 has an acoustic impedance of about 30 MRayls and the subject has an acoustic impedance of about 1.54 MRayls and thus the difference thereof is larger, an acoustic mismatching occurs; therefore, the frequency bandwidth is narrowed. In order to obviate such an acoustic mismatching, when a material having an acoustic impedance intermediate between those of the piezoelectric elements 1 and the subject is used for the acoustic matching layer, it is possible to increase the frequency bandwidth.

[0222] When the number of steps wherein the acoustic impedance of the acoustic matching layer is gradually approached toward that of the subject from that of the piezoelectric elements is increased, it is possible to further increase the frequency bandwidth. Therefore, when the number of layers of the acoustic matching layer is increased from one to two, or from two to three, and so on, a broader bandwidth can be provided.

[0223] In addition, by decreasing the number of layers of the acoustic matching layer which is to be divided in a manner similar to the piezoelectric elements 1, even when they are divided into narrow intervals (for example, 0.1 mm), the processing can be performed in a stable manner, and thus, it is possible to fabricate the ultrasonic probe in a uniform and precise manner without decreasing the directivity.

[0224] For example, an angle of the directivity when the piezoelectric elements 1 having a frequency of 3.5 MHz are divided into intervals of 0.38 mm corresponding to the gaps of the divided piezoelectric elements 1 (a state where two parts divided into intervals of 0.19 mm are electrically coupled), as defined at a level of -6 dB, corresponds to a directivity angle of about 23 degrees for a configuration type where the acoustic matching layer 2 is divided together with the piezoelectric elements 1. Furthermore, it was configured such that silicon rubber materials are filled in the division grooves of the piezoelectric elements 1 and the first and second acoustic matching layers 2a and 2b.

[0225] In a configuration type where the piezoelectric elements 1 are divided with the same specifications by the above-mentioned method, and among the three-layered acoustic matching layer, the first and second acoustic matching layers 2a and 2b disposed close to the piezoelectric elements 1 are divided in a manner similar to the piezoelectric elements 1, while the third acoustic matching layer is not divided, the directivity characteristics of ultrasonic waves in the arrangement direction of the piezoelectric elements 1 were measured in a state where a plurality of third acoustic matching layers 2

disposed close to the subject is prepared, respectively formed of silicon rubber (hardness: 76 on shore A hardness, acoustic velocity: 915 m/sec, acoustic impedance: 2.1 MRayls), chloroprene rubber (hardness: 70 on shore A hardness, acoustic velocity: 1630 m/sec, acoustic impedance: 2.16 MRayls), ethylene-propylene copolymer rubber (hardness: 65 on shore A hardness, acoustic velocity: 1480 m/sec, acoustic impedance: 1.94 MRayls), acrylonitrile-butadiene copolymer rubber (hardness: 60 on shore A hardness, acoustic velocity: 1640 m/sec, acoustic impedance: 1.97 MRayls), and urethane rubber (hardness: 78 on shore A hardness, acoustic velocity: 1850 m/sec, acoustic impedance: 1.98 MRayls), and the respective acoustic matching layers 2 are placed on the surface of the piezoelectric elements 1, and an acoustic lens formed of silicon rubber is provided on the upper surface of the acoustic matching layer 2.

[0226] As a result of the measurement, it can be concluded that the directivity characteristics changed depending on the materials of the third acoustic matching layer 2. Moreover, in the division grooves (at this time, the division groove has a width of about 0.03 mm) of the divided piezoelectric elements 1 and the first and second acoustic matching layers, silicon rubber materials were filled in a manner similar to the configuration where the division is performed up to the second acoustic matching layer 2.

[0227] Moreover, as a material other than the urethane rubber as mentioned above, a material in which an arbitrary amount of fillers such as alumina, carbon or calcium carbonate is filled in order to adjust an acoustic impedance was used.

[0228] The difference in the directivity characteristics was neither correlated with nor influenced by the hardness, the acoustic impedance, and the like of the materials. However, the acoustic velocity characteristics of the materials of the third acoustic matching layers 2 had influence on, that is, was correlated with, the directivity characteristics, and showed good correlation.

[0229] The relationship between the directivity angle measured at a level of -6 dB using a frequency of 3.5 MHz and an acoustic velocity of the material is illustrated in FIG. 2 (described above). As illustrated in FIG. 2, it showed good correlation with an acoustic velocity, and a correlation coefficient was 0.86. In this respect, in the configuration where the acoustic matching layer 2 disposed close to the subject is not divided, it can be concluded that it is necessary to focus on the acoustic velocity in order to increase the directivity. The directivity angles when the respective materials were used for the acoustic matching layer 2 are as follows.

[0230] The respective directivity angles were 25 degrees for the silicon rubber, 23.5 degrees for the chloroprene rubber, 23.5 degrees for the ethylene-propylene copolymer rubber, 22.9 degrees for the acrylonitrile-butadiene copolymer rubber, and 20 degrees for the urethane rubber. Moreover, it is considered that the measurement result has a deviation of about  $\pm 0.5$  degrees.

[0231] Therefore, even when the entire multi-layered acoustic matching layers are not divided unlike the piezoelectric elements 1, in order to obtain directivity characteristics equal to or better than that of the configuration where the acoustic matching layers are divided, it can be concluded that it is necessary to regulate the acoustic velocity of the acoustic matching layer, and rubber elastic materials can provide an acoustic velocity of 1650 m/sec or less.

[0232] Based on the results, in the present embodiment, the acoustic matching layer 2 is configured to have three layers,

and the third acoustic matching layer **2c** disposed close to the subject is formed of rubber elastic materials having an acoustic velocity of 1650 m/sec or less and is not divided, so that the directivity can be increased.

[0233] Moreover, since the acoustic matching layer **2** is configured to have three layers, it is possible to provide a broader bandwidth. When the directivity angles were compared with the directivity angle of the prior art configuration where the acoustic matching layer **2** is divided together with the piezoelectric elements **1**, in order to obtain a directivity angle approximately equal to the directivity angle of the prior art configuration, it is necessary to form the acoustic matching layer **2** using a material having an acoustic velocity in the vicinity of 1650 m/sec. Moreover, in order to increase the directivity, it can be concluded from the result illustrated in FIG. 2 that it is necessary to use a material having an acoustic velocity of 1650 m/sec or less, for example, a material such as silicon rubber.

[0234] Moreover, in the case of the urethane rubber which showed a narrow directivity angle, since among urethane rubbers, some kinds of products (for example, medium-size urethane resin of a grade UE-644, manufactured by SANYU REC Co., Ltd. has an acoustic velocity of 1580 m/sec and an acoustic impedance of 2.1 MRayls) have an acoustic velocity in the vicinity of 1650 m/sec or less, it cannot be said that the urethane rubber narrows the directivity angle, and the directivity angle is determined by an acoustic velocity. Therefore, when materials having an acoustic velocity of 1650 m/sec or less are selected, the materials are basically narrowed down to the rubber elastic materials.

[0235] As described above, in the configuration where the acoustic matching layer **2** is not divided unlike the piezoelectric elements **1** but is provided as one sheet of continuous film, in order to secure or increase the directivity, it can be concluded that it is necessary to focus on an acoustic velocity of the material of the acoustic matching layer **2**.

[0236] For example, a material of the third acoustic matching layer **2c**, having an acoustic impedance in the vicinity of 2 MRayls as the materials mentioned above is not limited to the rubber elastic materials but plastic materials are also usable. For example, materials in which filling materials are filled in polyethylene resin, polystyrene resin, or the epoxy resin described in Patent Document 2 may be used, and such materials have an acoustic velocity of about 1800 m/sec or more. When the third acoustic matching layer **2c** is formed of such materials and is not divided similar to the configuration of the present embodiment, the directivity is narrowed, as is clearly understood from the relationship shown in FIG. 2. Therefore, when such materials are used, it is necessary to configure such that the acoustic matching layer **2** is divided in a manner similar to the piezoelectric elements **1**, so that the directivity is increased.

[0237] In addition, although the metal film of the film **9** provided between the first and second acoustic matching layers is formed of a material such as copper, since copper has a high acoustic velocity of 4700 m/sec and can be formed to a thickness of 5  $\mu\text{m}$  or less, it does not have much influence on the frequency characteristics and no further consideration is needed. However, the polymer film of the film **9** is formed of a material such as polyimide.

[0238] The polymer film has an acoustic impedance of about 3 MRayls, smaller than those of the first and second acoustic matching layers **2a** and **2b**, and has a low acoustic velocity of 2200 m/sec; therefore, a thickness thereof has

influence on the frequency characteristics. In the configuration where three acoustic matching layers are provided, the acoustic impedances of the respective acoustic matching layers are typically set such that the first acoustic matching layer **2a** has an acoustic impedance in the range of 8 to 20 MRayls, the second acoustic matching layer **2b** has an acoustic impedance in the range of 3 to 8 MRayls, and the third acoustic matching layer **2c** has an acoustic impedance in the range of 1.7 to 2.4 MRayls.

[0239] In the present embodiment, when the first acoustic matching layer is formed of a material having an acoustic impedance of 10 MRayls, the second acoustic matching layer is formed of a material having an acoustic impedance of 4 MRayls, the polymer film of the film **9** is formed of polyimide, so that the acoustic matching layer has three layers, a calculation result of a fractional bandwidth of the frequency characteristics at -6 dB with a frequency of 3.5 MHz is illustrated in FIG. 10.

[0240] In FIG. 10, a horizontal axis represents a thickness of the polymer film of polyimide as the film **8**, normalized to wavelength, and the vertical axis represents a fractional bandwidth (bandwidth/central frequency) at -6 dB.

[0241] As will be clearly understood from FIG. 10, since the acoustic matching layer has three layers, it was possible to obtain broad bandwidth characteristics having a fractional bandwidth of 90 percents or more, and the fractional bandwidth showed a tendency to decrease as the thickness of the film **9** increases. When it is considered that the acoustic matching layer is configured to have three layers in order to provide a broader bandwidth, it is necessary to secure a fractional bandwidth of at least 90 percent or more. Here, when the fractional bandwidth is set to 90 percent or more, the thickness of the polymer film of the film **9** has to be set to 0.07 wavelength or less. In this case, since the frequency is 3.5 MHz and polyimide is used for the polymer film of the film **9**, the thickness of 0.07 wavelength or less corresponds to 44  $\mu\text{m}$  or less.

[0242] As described above, when a layer is disposed between the acoustic matching layers and an acoustic impedance of the layer is outside the range of the acoustic impedance of the acoustic matching layers, it is necessary to set the thickness or the like so that the frequency characteristics are not influenced much; in this case, the influence was clearly eliminated by setting the thickness to 0.07 wavelength or less.

[0243] In this way, since a rubber elastic material is used for the third acoustic matching layer disposed close to the subject side of the acoustic matching layers, it is possible to provide broader frequency bandwidth and increase the directivity. Moreover, since it is not necessary to process and divide the third acoustic matching layer together with the piezoelectric elements, it is possible to eliminate difficulties in processing. Furthermore, since the electric terminal is drawn from the conductor provided to the film, it is possible to obtain a stable and high-quality ultrasonic probe. Accordingly, phase control can be freely performed by using a greater number of piezoelectric elements, and thus an ultrasonic beam can be condensed narrow. Furthermore, since the ultrasonic beam can be deflected, it is possible to provide an ultrasonic probe capable providing a high-resolution ultrasonic image.

[0244] Moreover, although the seventh embodiment has been described for the case where the third acoustic matching layer **2c** is formed of synthetic rubbers such as chloroprene rubber, ethylene-propylene copolymer rubber, and acrylonitrile-butadiene copolymer rubber, the same advantages can be

obtained when the third acoustic matching layer **2c** is mainly composed of other synthetic rubber materials such as butadiene rubber, isoprene rubber, styrene-butadiene copolymer rubber or acryl rubber.

[0245] Furthermore, although the seventh embodiment has been described for the case where the third acoustic matching layer **2c** is formed of a rubber elastic material such as synthetic rubber, silicon rubber or urethane rubber, the same advantages can be obtained when the third acoustic matching layer **2c** is formed of other elastomeric materials having a rubber elastic material.

[0246] Moreover, although the seventh embodiment has been described for the case where a plurality of piezoelectric elements is arranged, the same advantage of the broader bandwidth can be provided when the acoustic matching layer is configured to have three or more layers, and a rubber elastic material is used for the acoustic matching layer disposed close to the subject, even when the piezoelectric elements are not arranged but form a single body.

[0247] Furthermore, although the seventh embodiment has been described for a so-called linear type in which a plurality of piezoelectric elements is arranged in an approximately straight line manner, the same advantages can be obtained for a convex type or a concave type in which a plurality of piezoelectric elements is arranged in a curved surface shape.

#### Embodiment 8

[0248] Hereinafter, an ultrasonic probe according to an eighth embodiment of the present invention will be described with reference to the drawings. FIG. 11 is a partially schematic perspective view of an ultrasonic probe **10** according to the eighth embodiment.

[0249] The ultrasonic probe **10** is configured to include a plurality of piezoelectric elements **1**, a three-layered acoustic matching layer **2** (**2a**, **2b** and **2c**) provided on a front surface in the thickness direction at a subject side (upper side in the drawing) so as to correspond to the respective piezoelectric elements **1**, a backing load member **3** provided, as necessary, on a rear surface (lower surface in the drawing) in the thickness direction of the piezoelectric elements **1** at a side opposite to the acoustic matching layer **2** (**2a**, **2b** and **2c**), and an acoustic lens **4** provided, as necessary, on the acoustic matching layer **2** (**2a**, **2b** and **2c**). The respective functions of the above-mentioned components are the same as those of the components described in the prior art.

[0250] A ground electrode **5** and a signal electrode **6** are provided on the front surface and the rear surface in the thickness direction *Z* of the piezoelectric elements **1**, respectively. The electrodes **5** and **6** are formed on the front surface and the rear surface of the piezoelectric elements **1**, respectively, by means of deposition or sputtering of gold and silver or silver printing.

[0251] Further detailed description will be provided below. Between the signal electrode **6** provided on the piezoelectric elements **1** made of materials such as PZT-based piezoelectric ceramic materials, PZN-PT-based or PMN-PT-based single-crystal piezoelectric materials, or a piezoelectric composite composed of the materials and polymers, and the backing load member **3**, a film **8** (first polymer film), in which a metal film of copper or the like is provided on a polymer film of polyimide or the like, is provided, the electric terminal **7** of the metal film of the film **8** is in contact with the signal electrode **6**, and the polymer film is in contact with the backing load member **3**.

[0252] Meanwhile, on the side of the ground electrode **5** provided on the surface of the piezoelectric elements **1**, a first acoustic matching layer **2a**, which is a conductor such as graphite (if it is an insulating material, the insulator is plated with metal to form a conductor). After the configuration described above is formed, a portion of the backing load member **3**, the film **8**, the piezoelectric elements **1**, and the first acoustic matching layer **2a** are processed and divided by means of a slicing machine or the like.

[0253] In portions corresponding to the division grooves, materials such as silicon rubber or urethane rubber, capable of reducing acoustic coupling are filled, and a film **9** (second polymer film) having a polymer film and a conductor of a metal film having a function of an electric terminal that is drawn from the ground electrode **5** via the first acoustic matching layer is provided on an upper surface of the first acoustic matching layer **2a** and the filled portions of the division grooves. Moreover, a second acoustic matching layer **2b** is provided on an upper surface of the film **9**, and a third acoustic matching layer **2c** is provided on an upper surface (at a subject side) of the second acoustic matching layer **2b**.

[0254] The film **9** and the second and third acoustic matching layers **2b** and **2c** are provided in a state where they are not divided but connected, as illustrated in the drawing. Moreover, as materials of the second and third acoustic matching layers **2b** and **2c**, materials mainly composed of a rubber elastic material, such as silicon rubber, chloroprene rubber, ethylene-propylene copolymer rubber, acrylonitrile-butadiene copolymer rubber, and urethane rubber are used. Furthermore, an acoustic lens **4** formed of materials such as silicon rubber is provided, as necessary, on an upper surface of the third acoustic matching layer **2c**.

[0255] The present embodiment is characterized in that neither the second acoustic matching layer **2b** nor the third acoustic matching layer **2c** is divided. When the second acoustic matching layer **2b** is not divided unlike the piezoelectric elements **1**, the directivity is narrowed as described above and it is thus not desirable. However, even when the second acoustic matching layer is not divided, it does not cause any problem as long as the directivity is not narrowed. Moreover, as described in the seventh embodiment, the smaller number of constituent components, the easier the division process can be performed.

[0256] In order to use the configuration where the second and third acoustic matching layers **2b** and **2c** are not divided so that the directivity is not narrowed, as illustrated in FIG. 2 and described in the seventh embodiment, it is necessary that the second acoustic matching layer **2b** is formed of the same rubber elastic material as the third acoustic matching layer **2c** and having an acoustic velocity of 1650 m/sec or less.

[0257] As materials of the second acoustic matching layer **2b** having an acoustic impedance in the range of 3 to 8 MRayls and an acoustic velocity of 1650 m/sec or less, a material in which fillers of metal powder (average grain size of 1.2  $\mu\text{m}$ ) are filled in acrylonitrile-butadiene copolymer rubber at a ratio of 9:1 in terms of weight percent, having an acoustic impedance of 5.3 MRayls and an acoustic velocity of 1070 m/sec, which provides desired characteristics as the second acoustic matching layer **2b** is used.

[0258] In this way, by filling fillers having a large density such as oxides or metal powder such as tungsten, silver, iron or nickel in a material mainly composed of synthetic rubber-based elastic materials, it is possible to obtain a material

having an acoustic impedance and an acoustic velocity needed by the second acoustic matching layer *2b*.

[0259] In addition, the thickness of the polymer film of the film **9** provided between the first acoustic matching layer and the second acoustic matching layer *2b* is set to 0.07 wavelength or less, similar to the first embodiment.

[0260] Moreover, although the eighth embodiment has been described for the case where the second and third acoustic matching layers *2b* and *2c* are formed of synthetic rubbers such as chloroprene rubber, ethylene-propylene copolymer rubber, and acrylonitrile-butadiene copolymer rubber, the same advantages can be obtained when the second and third acoustic matching layers *2b* and *2c* are mainly composed of other synthetic rubber materials such as butadiene rubber, isoprene rubber, styrene-butadiene copolymer rubber or acryl rubber.

[0261] In this way, since a rubber elastic material is used for the second and third acoustic matching layers, it is possible to provide broader frequency bandwidth and increase the directivity. Moreover, since it is not necessary to process and divide the second and third acoustic matching layers together with the piezoelectric elements, it is possible to eliminate difficulties in processing. Furthermore, since the electric terminal is drawn from the conductor provided to the film, it is possible to obtain a stable and high-quality ultrasonic probe. Accordingly, phase control can be freely performed by using a greater number of piezoelectric elements, and thus an ultrasonic beam can be condensed narrow. Furthermore, since the ultrasonic beam can be deflected, it is possible to provide an ultrasonic probe capable providing a high-resolution ultrasonic image.

[0262] Furthermore, although the eighth embodiment has been described for the case where the second and third acoustic matching layers *2b* and *2c* are formed of a rubber elastic material such as synthetic rubber, silicon rubber or urethane rubber, the same advantages can be obtained when the second and third acoustic matching layers *2b* and *2c* are formed of other elastomeric materials having a rubber elastic material.

[0263] In addition, although the eighth embodiment has been described for the case where the first acoustic matching layer is divided together with the piezoelectric elements **1**, the same advantages can be provided when the first acoustic matching layer *2a* and the film **9** are divided together with the piezoelectric elements **1**, and the second and third acoustic matching layers *2b* and *2c* are formed thereon having a rubber elastic material having an acoustic velocity of 1650 m/sec or less.

[0264] Furthermore, although the eighth embodiment has been described for a so-called linear type in which a plurality of piezoelectric elements is arranged in an approximately straight line manner, the same advantages can be obtained for a convex type or a concave type in which a plurality of piezoelectric elements is arranged in a curved surface shape.

[0265] Although the invention has been described in detail with reference to specific embodiments, it will be apparent to those skilled in the art that various modifications and variations can be made to the above-described embodiments of the present invention without departing from the spirit or scope of the invention.

[0266] This application is based upon and claims the benefit of priority from the prior Japanese Patent Application

Nos. 2006-023169 filed on Jan. 31, 2006, and 2006-023170 filed on Jan. 31, 2006, the entire contents of which are incorporated herein by reference.

#### INDUSTRIAL APPLICABILITY

[0267] The ultrasonic probe according to the present invention can be applied to various medical fields in which an ultrasonic diagnosis is conducted on a subject such as a human body and to an industrial field.

1. An ultrasonic probe, comprising:
  - a plurality of piezoelectric elements; and
  - an acoustic matching layer formed of a rubber elastic material, provided on one surface of the plurality of piezoelectric elements.
2. The ultrasonic probe according to claim 1, where an acoustic impedance of the rubber elastic material is smaller than an acoustic impedance of the piezoelectric elements and larger than an acoustic impedance of the subject.
3. The ultrasonic probe according to claim 1, wherein an acoustic velocity of the acoustic matching layer has a value of 1650 m/sec or less.
4. The ultrasonic probe according to claim 1, further comprising an acoustic matching layer disposed between the acoustic matching layer and the plurality of piezoelectric elements and individually arranged so as to correspond to the respective piezoelectric elements.
5. An ultrasonic probe, comprising:
  - a plurality of piezoelectric elements;
  - a third acoustic matching layer provided on one surface of the plurality of piezoelectric elements and having an acoustic impedance in the range of 1.8 to 2.2 MRayls and an acoustic velocity of 1650 m/sec or less; and
  - first and second acoustic matching layers provided between the third acoustic matching layer and the plurality of piezoelectric elements.
6. The ultrasonic probe according to claim 5, wherein the third acoustic matching layer is provided on one surface of the plurality of piezoelectric elements, and wherein the first and second acoustic matching layers are individually arranged so as to correspond to the respective piezoelectric elements.
7. The ultrasonic probe according to claim 5, wherein the third acoustic matching layer is formed of a rubber elastic material.
8. An ultrasonic probe, comprising:
  - a plurality of piezoelectric elements;
  - second and third acoustic matching layers provided on one surface of the plurality of piezoelectric elements and having an acoustic velocity of 1650 m/sec or less; and
  - a first acoustic matching layer provided between the second and third acoustic matching layers and the plurality of piezoelectric elements.
9. The ultrasonic probe according to claim 8, wherein the second and third acoustic matching layer are provided on one surface of the plurality of piezoelectric elements, and wherein the first acoustic matching layer is individually arranged so as to correspond to the respective piezoelectric elements.
10. The ultrasonic probe according to claim 8, wherein the second and third acoustic matching layers are formed of a rubber elastic material.

11. An ultrasonic probe, comprising:  
a plurality of piezoelectric elements;  
a fourth acoustic matching layer provided on one surface of the plurality of piezoelectric elements and having an acoustic velocity of 1650 m/sec or less; and  
first, second and third acoustic matching layers provided between the fourth acoustic matching layer and the plurality of piezoelectric elements.
12. The ultrasonic probe according to claim 11, wherein the fourth acoustic matching layer is provided on one surface of the plurality of piezoelectric elements, and  
wherein the first, second and third acoustic matching layers are individually arranged so as to correspond to the respective piezoelectric elements.
13. The ultrasonic probe according to claim 11, wherein the third and fourth acoustic matching layers are provided on one surface of the plurality of piezoelectric elements, and  
wherein the first and second acoustic matching layers are individually arranged so as to correspond to the respective piezoelectric elements.
14. The ultrasonic probe according to claim 13, wherein the third acoustic matching layer is formed of a rubber elastic material and has an acoustic velocity of 1650 m/sec or less.
15. The ultrasonic probe according to claim 11, wherein the fourth acoustic matching layer is formed of a rubber elastic material.
16. An ultrasonic probe having a backing load member and a plurality of piezoelectric elements arranged on an upper surface of the backing load member, the ultrasonic probe comprising:  
a first polymer film provided between the backing load member and the plurality of piezoelectric elements and provided with electric terminals individually arranged so as to correspond to the respective piezoelectric elements;  
a first acoustic matching layer provided on an upper surface of the plurality of piezoelectric elements and individually arranged so as to correspond to the respective piezoelectric elements;  
a second polymer film provided on an upper surface of the first acoustic matching layer and provided with electric terminals individually arranged so as to correspond to the respective piezoelectric elements;  
a second acoustic matching layer provided on an upper surface of the second polymer film and individually arranged so as to correspond to the respective piezoelectric elements; and  
a third acoustic matching layer provided on an upper surface of the second acoustic matching layer and formed of a rubber elastic material.
17. The ultrasonic probe according to claim 16, wherein an acoustic velocity of the third acoustic matching layer has a value of 1650 m/sec or less.
18. The ultrasonic probe according to claim 16, wherein an acoustic impedance of the second polymer film is smaller than an acoustic impedance of the second acoustic matching layer and has a thickness of 0.07 wavelength or less at using frequency.
19. An ultrasonic probe having a backing load member and a plurality of piezoelectric elements arranged on an upper surface of the backing load member, the ultrasonic probe comprising:  
a first polymer film provided between the backing load member and the plurality of piezoelectric elements and provided with electric terminals;  
a first acoustic matching layer provided on an upper surface of the plurality of piezoelectric elements and individually arranged so as to correspond to the respective piezoelectric elements;  
a second polymer film provided on an upper surface of the first acoustic matching layer and provided with electric terminals individually arranged so as to correspond to the respective piezoelectric elements;  
a second acoustic matching layer provided on an upper surface of the second polymer film and formed of a rubber elastic material; and  
a third acoustic matching layer provided on an upper surface of the second acoustic matching layer and formed of a rubber elastic material.
20. The ultrasonic probe according to claim 19, wherein an acoustic velocity of the second and third acoustic matching layers has a value of 1650 m/sec or less.
21. The ultrasonic probe according to claim 19, wherein the acoustic impedance of the second polymer film is smaller than an acoustic impedance of the second acoustic matching layer and has a thickness of 0.07 wavelength or less at using frequency.
22. The ultrasonic probe according to claim 1, wherein the rubber elastic material is mainly composed of synthetic rubber, silicon rubber, urethane rubber, or elastomer.
23. The ultrasonic probe according to claim 22, wherein the synthetic rubber is mainly composed of ethylene-propylene copolymer rubber, chloroprene rubber, butadiene rubber, isoprene rubber, styrene-butadiene copolymer rubber, or acrylonitrile-butadiene copolymer rubber.
24. The ultrasonic probe according to claim 7, wherein the rubber elastic material is mainly composed of synthetic rubber, silicon rubber, urethane rubber, or elastomer.
25. The ultrasonic probe according to claim 24, wherein the synthetic rubber is mainly composed of ethylene-propylene copolymer rubber, chloroprene rubber, butadiene rubber, isoprene rubber, styrene-butadiene copolymer rubber, or acrylonitrile-butadiene copolymer rubber.
26. The ultrasonic probe according to claim 10, wherein the rubber elastic material is mainly composed of synthetic rubber, silicon rubber, urethane rubber, or elastomer.
27. The ultrasonic probe according to claim 26, wherein the synthetic rubber is mainly composed of ethylene-propylene copolymer rubber, chloroprene rubber, butadiene rubber, isoprene rubber, styrene-butadiene copolymer rubber, or acrylonitrile-butadiene copolymer rubber.
28. The ultrasonic probe according to claim 15, wherein the rubber elastic material is mainly composed of synthetic rubber, silicon rubber, urethane rubber, or elastomer.
29. The ultrasonic probe according to claim 28, wherein the synthetic rubber is mainly composed of ethylene-propylene copolymer rubber, chloroprene rubber, butadiene rubber, isoprene rubber, styrene-butadiene copolymer rubber, or acrylonitrile-butadiene copolymer rubber.
30. The ultrasonic probe according to claim 16, wherein the rubber elastic material is mainly composed of synthetic rubber, silicon rubber, urethane rubber, or elastomer.
31. The ultrasonic probe according to claim 30, wherein the synthetic rubber is mainly composed of ethylene-propylene copolymer rubber, chloroprene rubber, butadiene rubber, isoprene rubber, styrene-butadiene copolymer rubber, or acrylonitrile-butadiene copolymer rubber.

**32.** The ultrasonic probe according to claim **19**, wherein the rubber elastic material is mainly composed of synthetic rubber, silicon rubber, urethane rubber, or elastomer.

**33.** The ultrasonic probe according to claim **32**, wherein the synthetic rubber is mainly composed of ethylene-propylene

copolymer rubber, chloroprene rubber, butadiene rubber, isoprene rubber, styrene-butadiene copolymer rubber, or acrylonitrile-butadiene copolymer rubber.

\* \* \* \* \*

专利名称(译)	超声波探头		
公开(公告)号	<a href="#">US20090062655A1</a>	公开(公告)日	2009-03-05
申请号	US12/162584	申请日	2007-01-25
申请(专利权)人(译)	松下电器产业有限公司.		
当前申请(专利权)人(译)	柯尼卡美能达, INC.		
[标]发明人	SAITO KOETSU		
发明人	SAITO, KOETSU		
IPC分类号	A61B8/14		
CPC分类号	A61B8/00 A61B8/4444 G10K11/02		
优先权	2006023170 2006-01-31 JP 2006023169 2006-01-31 JP		
其他公开文献	US8454518		
外部链接	<a href="#">Espacenet</a> <a href="#">USPTO</a>		

摘要(译)

提供一种超声波探头，其能够消除处理中的困难，增加超声波的方向性，并且获得高分辨率的诊断图像。超声波探头10构成为包括多个压电元件1，声学匹配层2设置在物体侧（图中的上侧）的厚度方向的前表面上，以对应于各个压电元件1如果需要，在压电元件1的与声匹配层2相对的一侧的厚度方向上的后表面（图中的下表面）上设置有背负载构件3，并且设置有声透镜4，声匹配层2由橡胶弹性材料形成，并且在多个压电元件1的一侧以非分割的平坦表面形状布置。

