



US 20180310910A1

(19) **United States**

(12) **Patent Application Publication**
FIESELMANN

(10) **Pub. No.: US 2018/0310910 A1**

(43) **Pub. Date: Nov. 1, 2018**

(54) **DEVICE AND METHOD FOR ULTRASOUND EXAMINATION**

Publication Classification

(71) Applicant: **SIEMENS HEALTHCARE GMBH,**
Erlangen (DE)

(51) **Int. Cl.**
A61B 8/00 (2006.01)
A61B 6/00 (2006.01)

(72) Inventor: **ANDREAS FIESELMANN,**
ERLANGEN (DE)

(52) **U.S. Cl.**
CPC *A61B 8/4416* (2013.01); *A61B 6/4411*
(2013.01); *A61B 6/4417* (2013.01); *A61B*
6/4464 (2013.01); *A61B 6/4476* (2013.01);
A61B 8/4411 (2013.01); *A61B 8/4218*
(2013.01); *A61B 8/54* (2013.01); *A61B 6/54*
(2013.01)

(21) Appl. No.: **15/963,488**

(57) **ABSTRACT**

(22) Filed: **Apr. 26, 2018**

With a device and an associated method, an ultrasound unit is coupled with a coupling unit to an existing x-ray unit. The ultrasound unit is guided with the aid of controllable elements of a positioning unit of the x-ray unit on a patient for an ultrasound examination. In this manner X-ray recordings and ultrasound recordings of an object can be produced.

(30) **Foreign Application Priority Data**

Apr. 26, 2017 (EP) 17168227.1

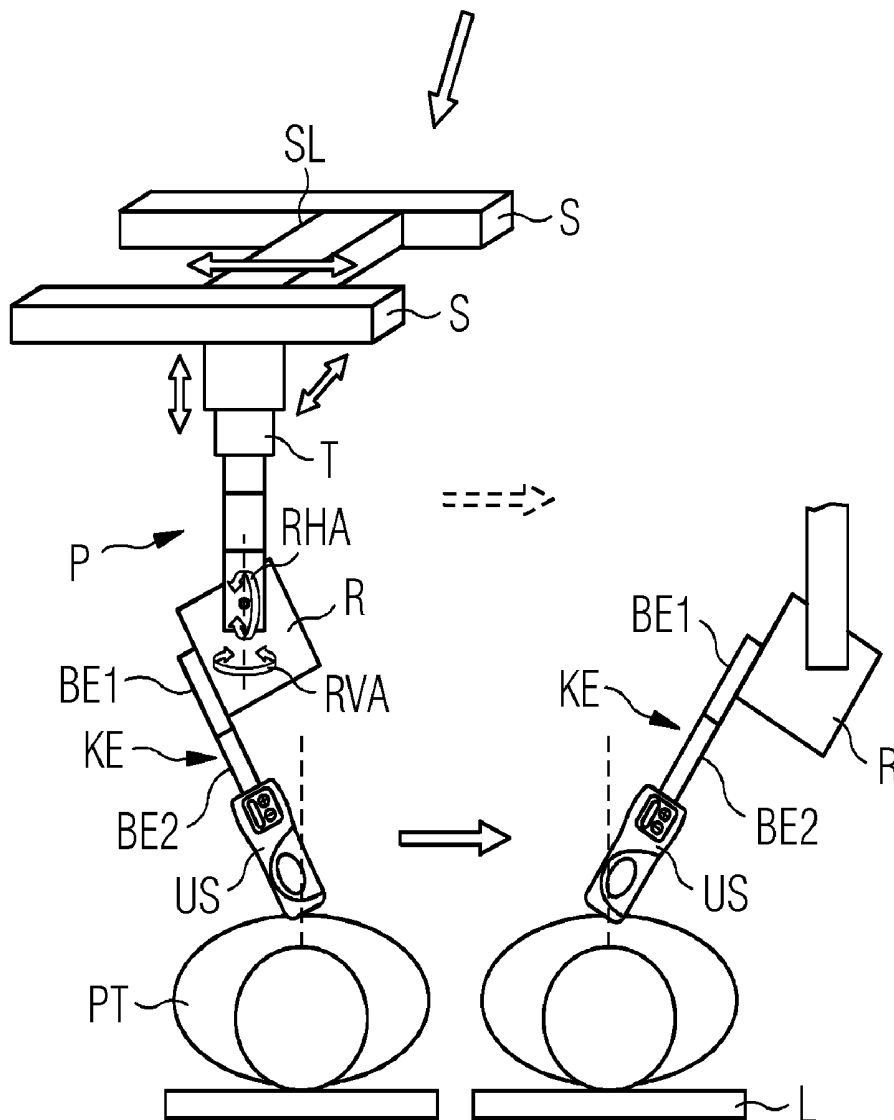

FIG 1

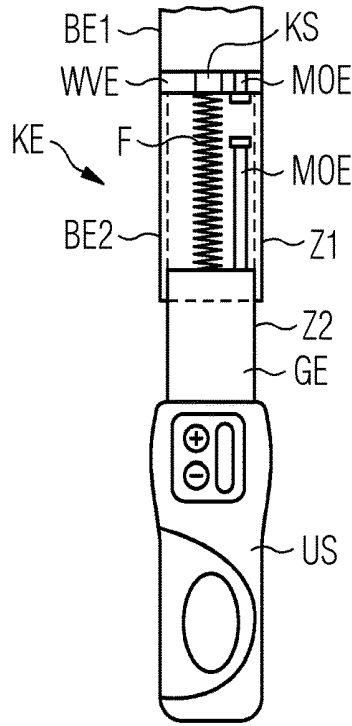

FIG 2

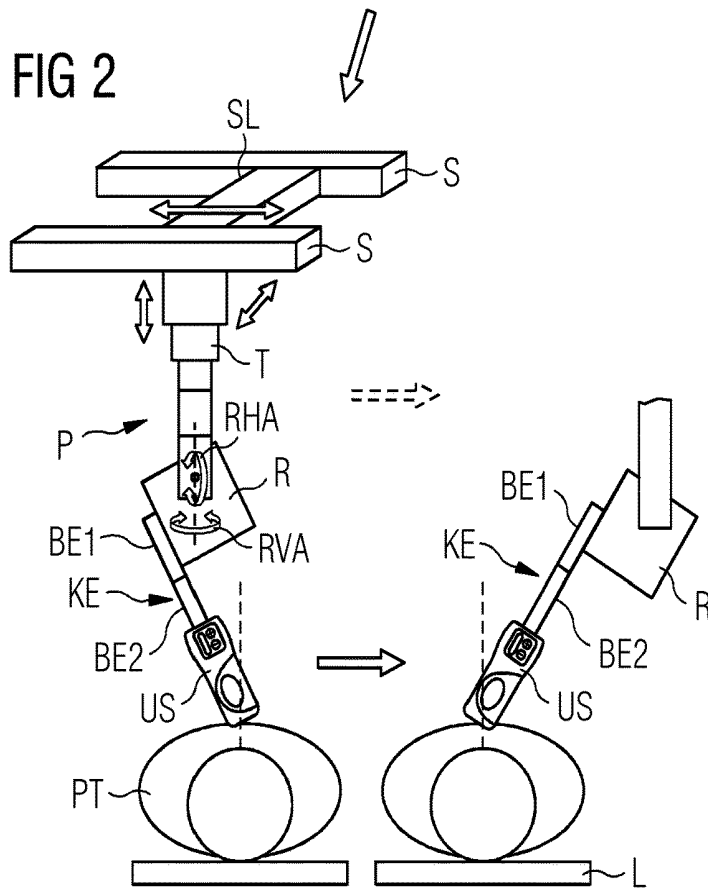

FIG 3

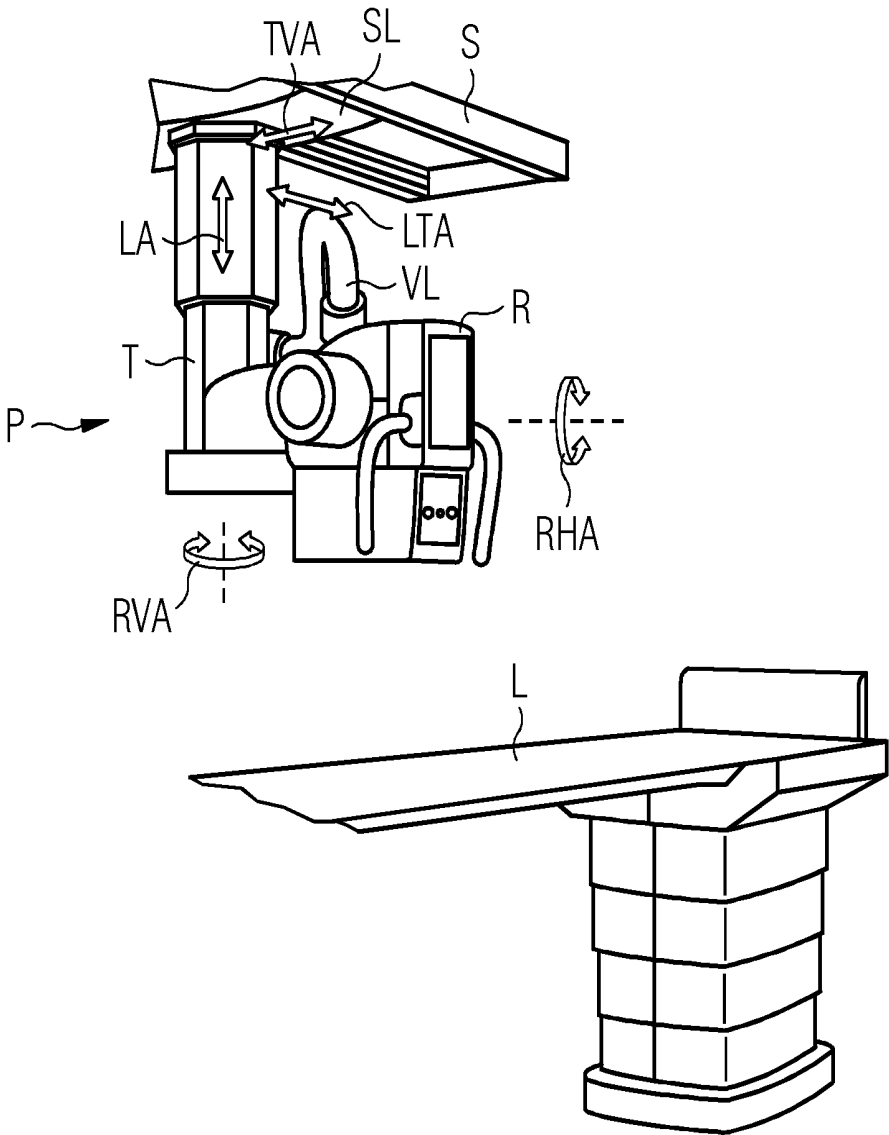

FIG 4

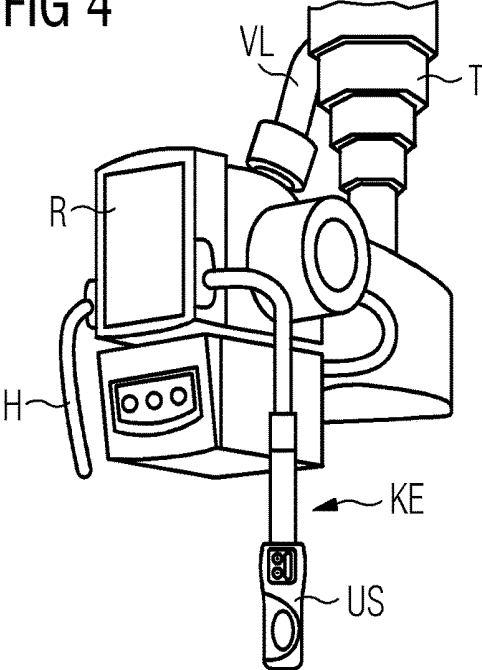
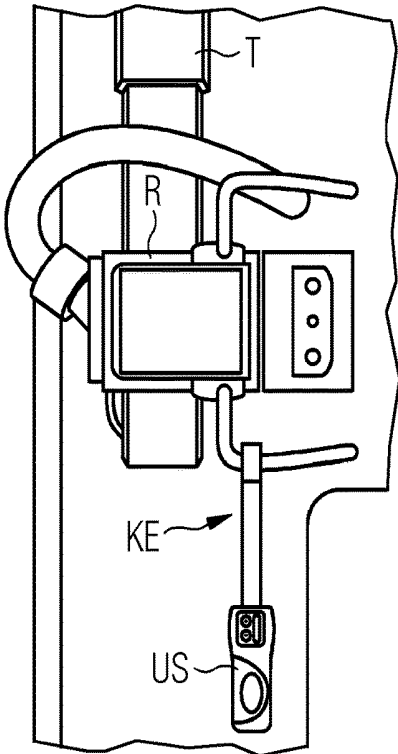

FIG 5



DEVICE AND METHOD FOR ULTRASOUND EXAMINATION

CROSS-REFERENCE TO RELATED APPLICATION

[0001] This application claims the priority, under 35 U.S.C. § 119, of European application EP 17168227.1, filed Apr. 26, 2017; the prior application is herewith incorporated by reference in its entirety.

BACKGROUND OF THE INVENTION

Field of the Invention

[0002] In order to locate and verify pathological symptoms of an organ of a patient, for instance, different imaging methods are often required in order to generate images of a region of a patient. For the initial diagnosis, ultrasound recordings as well as individual or 3D x-ray recordings could be produced, for instance. The disadvantage with the different recordings is that these are produced by two separate recording systems. Therefore in addition to controllable and exactly alignable x-ray recording units, individual x-ray recordings or a series of x-ray recordings of regions of a patient to be examined are generated and in addition to this in a subsequent work step, ultrasound recordings are recorded with an ultrasound unit which is guided or is to be aligned manually. A possible assignment of abnormalities in the x-ray or ultrasound image is down to the judgment of the treating physician.

SUMMARY OF THE INVENTION

[0003] The object underlying the present invention is to specify a device and a method, with which at least two different image recording methods are possible.

[0004] With the subject matter of the invention, a device and an associated method are present, in which x-ray recordings of an object can be produced with an x-ray unit, wherein the x-ray unit can be aligned with the object using an alignable positioning unit. With this device and the associated method, provision is made for an ultrasound unit for producing ultrasound recordings, wherein the ultrasound unit is aligned with the object using the positioning unit of the x-ray unit.

[0005] The invention is advantageous in that the x-ray and ultrasound images are generated using a device and an associated method, wherein in each case the same coordinate system forms the basis of the images to be generated.

[0006] The invention is advantageous in that the features in the x-ray and ultrasound image can be related to one another.

[0007] The invention is advantageous in that both the ultrasound unit and the x-ray unit can be used as a telemedical apparatus.

[0008] The invention is advantageous in that the kinematics of the positioning unit of an existing x-ray unit is used for the alignment or guidance of an ultrasound unit.

[0009] The invention is advantageous in that the remote-controllable positioning unit takes the pressure off a physician.

[0010] The invention is advantageous in that images can be generated with different contrasts, wherein soft tissue and bones can be easily seen in the ultrasound image and the x-ray image, respectively.

[0011] Other features which are considered as characteristic for the invention are set forth in the appended claims.

[0012] Although the invention is illustrated and described herein as embodied in a device and a method for ultrasound examination, it is nevertheless not intended to be limited to the details shown, since various modifications and structural changes may be made therein without departing from the spirit of the invention and within the scope and range of equivalents of the claims.

[0013] The construction and method of operation of the invention, however, together with additional objects and advantages thereof will be best understood from the following description of specific embodiments when read in connection with the accompanying drawings.

BRIEF DESCRIPTION OF THE SEVERAL VIEWS OF THE DRAWING

[0014] FIG. 1 is a diagrammatic, front view of an ultrasound unit with a coupling unit according to the invention;

[0015] FIG. 2 is a schematic view of a device combination;

[0016] FIG. 3 is a perspective view of an x-ray unit;

[0017] FIG. 4 is a perspective view of the device combination; and

[0018] FIG. 5 is a further perspective view of the device combination.

DETAILED DESCRIPTION OF THE INVENTION

[0019] The subject matter of the invention forms a device and an associated method for x-ray and/or ultrasound examination in which an ultrasound unit can be fastened with a coupling unit to an x-ray unit. The x-ray unit is positioned and aligned using a positioning unit. In one embodiment variant, the positioning unit has the controllable axes required to position and control the x-ray unit. The ultrasound unit is positioned on the patient using the positioning unit of the x-ray unit and is guided or aligned in accordance with the control commands input on a control element by an assistant or a physician. To align the ultrasound unit in a non-restrictive manner, the positioning unit has a plurality of degrees of freedom.

[0020] Referring now to the figures of the drawings in detail and first, particularly to FIG. 1 thereof, there is shown an ultrasound unit US with a coupling unit KE. In this embodiment and view, the coupling unit KE is made up of a first fastening unit BE1 and a second fastening unit BE2. An active connecting element unit WVE is arranged between the first and the second fastening unit BE1, BE2. While the first fastening unit BE1 has fastening-specific elements for a support or docking stations provided especially on the x-ray and/or the positioning unit P, the second fastening unit BE2 is embodied such that this is made up of a first and second hollow body Z1, Z2, for instance. The second hollow body Z2 can be integrated by way of guide elements into the first hollow body Z1 or can be inserted herein. The accommodation of the second hollow body Z2 in the interior of the first hollow cylinder Z1 is regulated by way of at least one damping element. In this embodiment variant, a spring F arranged in the first hollow body Z1 is provided as a damping element. The ultrasound unit US is arranged at the open end of the second hollow body Z2. An active connecting element unit WVE, which permits a

tolerance-free connection between both fastening units BE1, BE2, is embodied between the first and second fastening unit BE1, BE2. The insertion of the second hollow body Z2 into the first hollow body Z1 is absorbed by the spring F arranged in the interior of the first hollow body Z1, as specified above. The spring force of the compressing spring F is captured by way of a force sensor KS. If the spring force of the compressing spring F exceeds a predetermined value, the active connecting element unit WVE is embodied such that the previously connected first and second fastening element BE1, BE2 separate. In this embodiment variant a further mechanical securing unit MOE is integrated in the first hollow body Z1. This mechanical securing unit MOE is embodied such that once the second hollow body Z2 has covered a distance in the first hollow body Z1, an opening mechanism in the active connecting element unit WVE is actuated and the first is separated from the second fastening unit BE1, BE2. In a further embodiment variant, the first fastening unit BE1 of the coupling unit KE can be omitted and the active connecting element unit WVE is directly connected with a corresponding docking station provided herefor on the x-ray unit R and/or positioning unit P.

[0021] FIG. 2 shows a schematic representation of an x-ray system. A device combination containing ultrasound unit US and x-ray unit R is arranged on this x-ray system. The ultrasound unit US is fastened with a coupling unit KE to the x-ray unit R. In this embodiment variant, the x-ray unit R can be aligned by way of a carriage SL guided on rails S and a telescopic arm T which can be moved on the carriage SL in the space toward a positioned object or patient PT. In this embodiment variant, the first fastening unit BE1 of the coupling unit KE can be fastened to docking stations provided herefor on the x-ray unit R. The carriage SL can be moved along the rail system S fastened on a ceiling, for instance. The telescopic arm T which can be varied in terms of length can be moved at right angles to the direction of movement of the carriage SL. An alignable unit having a plurality of controllable axes is arranged at the end of the telescopic arm T. The x-ray unit R is then fastened to this unit. A patient PT positioned on a couch, for instance, is shown. If an ultrasound examination is to be generated with ultrasound recordings of a region of a patient PT, the ultrasound unit US fastened to a coupling unit KE is fastened to docking stations provided herefor on the x-ray unit R or the positioning unit P. According to an ultrasound examination to be carried out, the ultrasound unit US is positioned on a specific area of the patient PT and the ultrasound recording is generated by tilting or twisting or swiveling the ultrasound unit US. The assistant or physician controls the positioning unit P by way of a control element. The control functions triggered by the control unit are converted by way of a control unit, not shown explicitly here, into control pulses for individual, electronically controllable electric motors in the positioning unit P in order to bring about an intended targeted alignment of the ultrasound unit US. A possible starting position or an initial alignment of the ultrasound unit US and a possible end position of the ultrasound unit US on the patient PT are shown in FIG. 2. In order to achieve this positioning of the ultrasound unit US, the carriage SL is moved, for instance according to the direction of movement indicated, while the extended telescopic arm T is slightly retracted and extended again while the x-ray unit R is simultaneously swiveled. The control unit can be embodied such that a presettable pressure of the ultrasound unit US on the predetermined body region of the patient PT is kept constant. If the patient PT has to move unpredictably, this movement is absorbed by the securing system integrated into the coupling unit KE, for instance

consisting of a monitoring of the spring pressure and a mechanical emergency tripping device, as far as a variance which can be preset individually to the patient. If the pressure of the ultrasound unit US on the patient PT becomes larger, tripping mechanisms in the active connecting element unit WVE are activated and the coupling unit KE detaches from the docking station connected to it on the positioning unit P or x-ray unit R. During the ultrasound examination the ultrasound unit US can be swiveled or tilted in a controlled manner by the physician, while the pressure on the patient PT remains the same. If the contact pressure of the ultrasound unit US changes to above a contact pressure which can be determined by the physician, either the active connecting element unit WVE opens between the first and second fastening unit BE1, BE2 or the control unit controls all electronic motors of the positioning unit P such that at least individual components are moved back by the positioning unit P or each of the hinges is released and these can be deflected in a predetermined direction or in all directions almost without resistance. In a further embodiment of the coupling unit KE, provision can be made for the second hollow cylinder Z2 to be entirely insertable into the first hollow cylinder Z1 when there is increased pressure from the ultrasound unit US on the patient PT. The second hollow cylinder is embodied as a sliding element GE. Furthermore, the first fastening unit BE1 could be embodied such that the second fastening unit BE2 is additionally received hereby. In a further embodiment variant a control unit can be embodied with control functions for the ultrasound unit US so that with this a straight scanning, tilting or swiveling can be carried out automatically. Guidance of the ultrasound unit US over a predetermined trajectory is likewise possible.

[0022] FIG. 3 shows an x-ray unit R fastened to a ceiling rail S. Corresponding to the x-ray unit R which can be positioned above the ceiling rail S, a height-adjustable and pivotable couch L, for instance with a detector unit, can be positioned. For precise positioning for an individual recording or a plurality of recordings during a trajectory of the x-ray unit R or the ultrasound unit US which can be fastened on the x-ray unit R, FIG. 3 indicates the corresponding axes for aligning the x-ray device R or the ultrasound unit US. The positioning and alignment of the x-ray unit R or the ultrasound unit US is carried out using a positioning unit P. In this view, the controllable axes required to position and align the x-ray unit R or ultrasound unit US are indicated. In this embodiment variant, an alignable unit having a plurality of controllable axes is arranged at the end of the telescopic arm T. Using this unit, a horizontal rotation RHA and for instance a vertical rotation about the telescopic axis RVA can be carried out. The x-ray unit R is fastened to this unit. The x-ray or ultrasound unit R arranged on the telescopic arm T can be adjusted in terms of length or height using the telescopic arm T, indicated by the vertical arrow LA. The telescopic arm T can be moved both longitudinally LTA and also transversally TVA on a carriage SL. The carriage SL can be positioned at any point along the rails S.

[0023] FIG. 4 shows a partial cutout of the ceiling-suspended x-ray unit R. A guide element H is provided on this x-ray unit R for its manual or semi-manual guidance or alignment. The guide element H can be arranged on both sides of the x-ray unit R. A coupling element KE attached to an ultrasound unit US can be embodied at its end such that with this a force closure on elements, for instance a guide element H, the x-ray unit R and/or on a docking station of the unit described below in FIG. 3 is enabled at the end of the telescopic arm T of the positioning unit P. Aside from the guide element H as a docking element, further fastening units can be provided or embodied for the coupling unit KE

of the ultrasound unit HS on the chassis or the diaphragm unit of the x-ray unit R and/or the positioning unit P.

[0024] FIG. 5 shows a further fastening variant on the guide element H of the x-ray unit R for the coupling element KE for guiding the ultrasound unit US.

[0025] The following is a summary list of reference numerals and the corresponding structure used in the above description of the invention:

- [0026] US ultrasound unit
- [0027] PT object, patient
- [0028] L couch unit
- [0029] SL carriage
- [0030] S rail
- [0031] T telescopic arm
- [0032] VL supply lines
- [0033] R x-ray unit
- [0034] P positioning unit
- [0035] LA arrow for height-adjustable telescopic arm
- [0036] TVA transversal translation
- [0037] LTA longitudinal translation
- [0038] RHA horizontal rotation
- [0039] RVA vertical rotation about the telescopic axis
- [0040] F spring
- [0041] KE coupling element
- [0042] Z1 first hollow body
- [0043] Z2 second hollow body
- [0044] H guide element
- [0045] KS force sensor
- [0046] GE sliding element
- [0047] MOE mechanical opening element
- [0048] BE1 first fastening element
- [0049] BE2 second fastening element
- [0050] WVE active connecting element unit

1. A device, comprising:
 - an alignable positioning unit;
 - an x-ray unit for producing x-ray recordings of an object, said x-ray unit being aligned with the object using said alignable positioning unit;
 - a coupling unit; and
 - an ultrasound unit for producing ultrasound recordings of the object, said ultrasound unit being fastened with said

coupling unit to said x-ray unit and/or said positioning unit and aligned with the object.

2. The device according to claim 1, wherein said coupling unit has a detachable fastening for said ultrasound unit fastened to said x-ray unit and/or said positioning unit.

3. The device according to claim 2, wherein said coupling unit is formed with a first and/or a second fastening unit, wherein a detachable connection with elements of said x-ray and/or said positioning unit can be produced with said first or said second fastening unit.

4. The device according to claim 3, wherein said coupling unit has a detachable active connecting element unit disposed between said first and said second fastening unit.

5. The device according to claim 3, wherein said first and/or said second fastening unit of said coupling unit has sensor elements for monitoring a contact pressure of said ultrasound unit on the object to be examined, wherein when a predetermined contact pressure of said ultrasound unit on the object to be examined is exceeded, said coupling unit becomes separated from said x-ray or said positioning unit.

6. The device according to claim 1, wherein said coupling unit has an active connecting element unit for separating said coupling unit from said x-ray or said positioning unit.

7. The device according to claim 1, wherein said alignable positioning unit has a control unit, said control unit generating control pulses for electric motors to be controlled on axes of said alignable positioning unit.

8. A method for producing x-ray recordings of an object with an x-ray unit, which comprises the steps of:

- aligning the x-ray unit with the object using an alignable positioning unit; and
- connecting an ultrasound unit for producing ultrasound recordings to a coupling unit on the alignable positioning unit and/or the x-ray unit and is aligned with the object.

9. The method according to claim 8, which further comprises introducing a separation of a fastening of the ultrasound unit to the x-ray unit and/or the positioning unit when a predetermined contact pressure of the ultrasound unit on the object is exceeded.

* * * * *

专利名称(译)	用于超声检查的装置和方法		
公开(公告)号	US20180310910A1	公开(公告)日	2018-11-01
申请号	US15/963488	申请日	2018-04-26
[标]申请(专利权)人(译)	西门子保健有限责任公司		
申请(专利权)人(译)	西门子医疗GMBH		
当前申请(专利权)人(译)	西门子医疗GMBH		
[标]发明人	FIESELMANN ANDREAS		
发明人	FIESELMANN, ANDREAS		
IPC分类号	A61B8/00 A61B6/00		
CPC分类号	A61B8/4416 A61B6/4411 A61B6/4417 A61B6/4464 A61B6/54 A61B8/4411 A61B8/4218 A61B8/54 A61B6/4476 A61B6/08 A61B6/4452 A61B6/4458 A61B6/5247 A61B6/547 A61B8/4254 A61B8/429 A61B8/5261		
优先权	2017168227 2017-04-26 EP		
外部链接	Espacenet USPTO		

摘要(译)

利用装置和相关方法，超声单元与耦合单元耦合到现有的X射线单元。超声波单元借助于患者上的X射线单元的定位单元的可控元件被引导以进行超声检查。以这种方式，可以产生物体的X射线记录和超声记录。

