



US 20170245833A1

(19) **United States**

(12) **Patent Application Publication**
Jensen

(10) **Pub. No.: US 2017/0245833 A1**

(43) **Pub. Date: Aug. 31, 2017**

(54) **TRANSVERSE OSCILLATION VECTOR ESTIMATION IN ULTRASOUND IMAGING**

(52) **U.S. Cl.**

CPC *A61B 8/5223* (2013.01); *G01S 7/52085* (2013.01); *A61B 8/145* (2013.01); *A61B 8/463* (2013.01); *A61B 8/5207* (2013.01); *A61B 8/06* (2013.01)

(71) Applicant: **B-K Medical Aps**, Herlev (DK)

(72) Inventor: **Jorgen Jensen**, Horsholm (DK)

(73) Assignee: **B-K Medical Aps**, Herlev (DK)

(21) Appl. No.: **15/054,339**

(22) Filed: **Feb. 26, 2016**

Publication Classification

(51) **Int. Cl.**

A61B 8/08 (2006.01)
A61B 8/06 (2006.01)
A61B 8/00 (2006.01)
G01S 7/52 (2006.01)
A61B 8/14 (2006.01)

(57) **ABSTRACT**

A method includes continuously transmitting, with a transducer array, an ultrasound signal in one direction. The method further includes beamforming, with a beamformer, an echo signal received by the transducer array using on a predetermined apodization function. The echo signal is generated in response to an interaction of the ultrasound signal with flowing structure. The method further includes estimating, with a velocity processor, a vector velocity of the flow, including velocity components, as a function of depth and time from the beamformed echo signals using transverse oscillation vector velocity estimation. The method further includes generating, with a measurement processor, a quantitative measurement from the velocity components. The method further includes visually displaying, with a display monitor, the quantitative measurement.

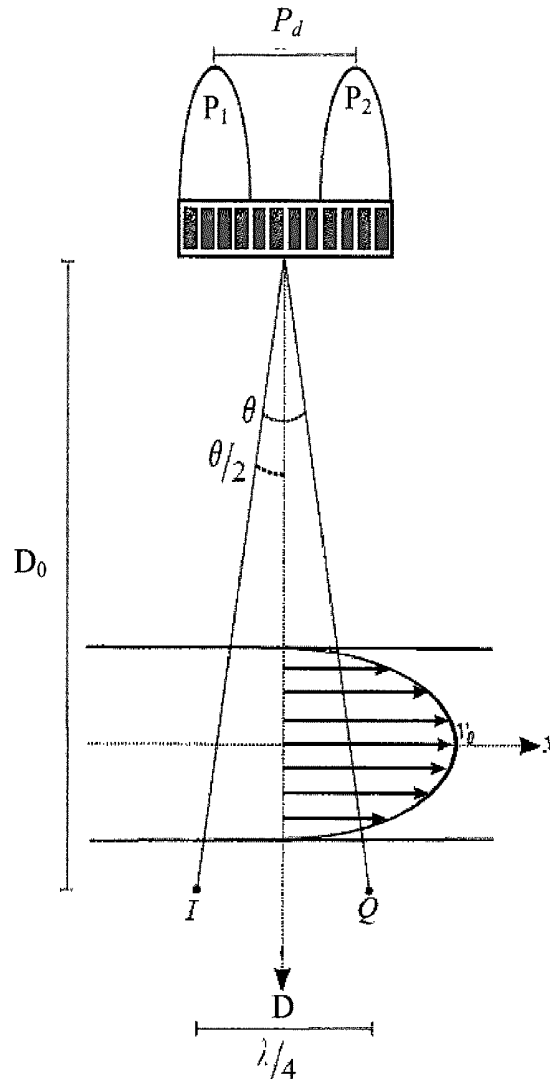

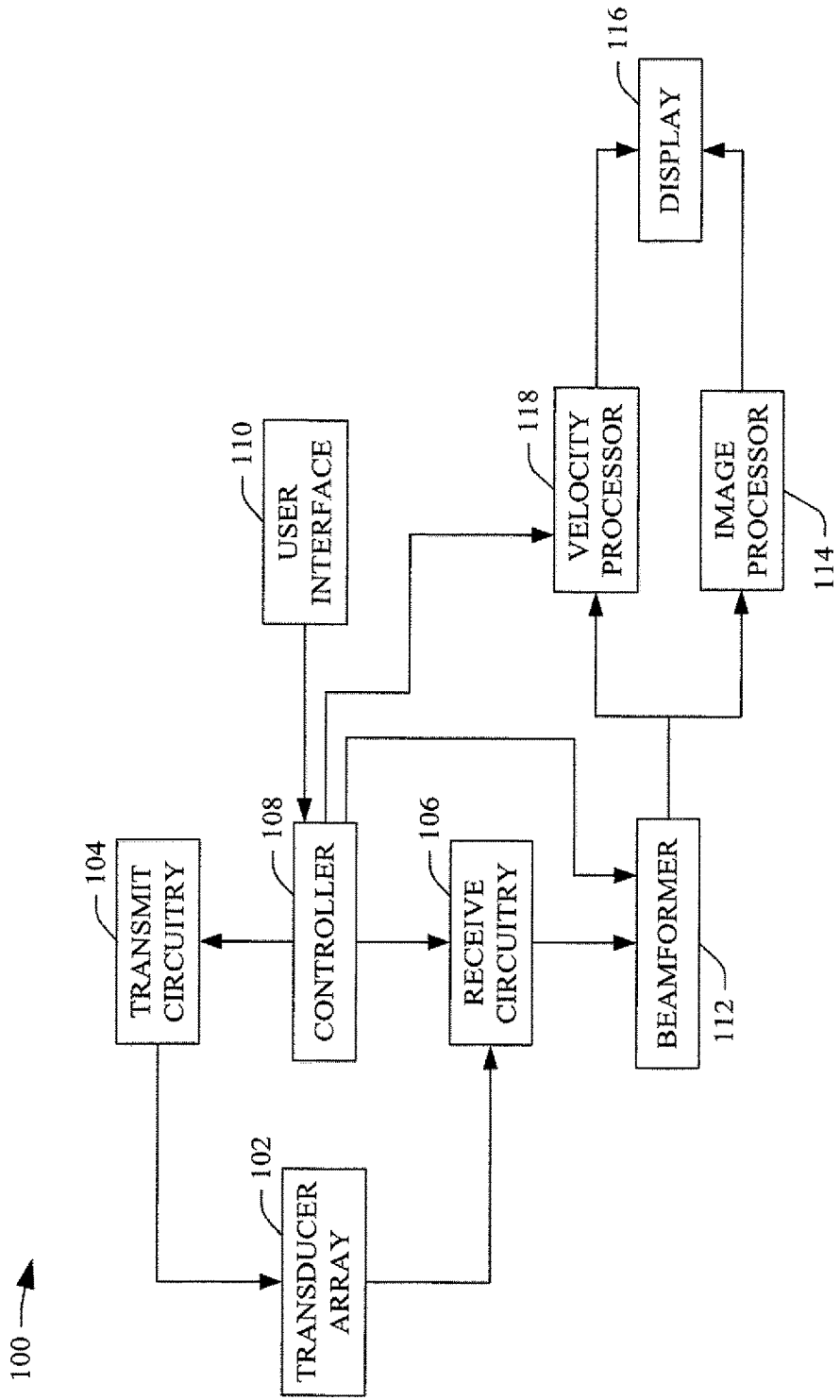

FIGURE 1

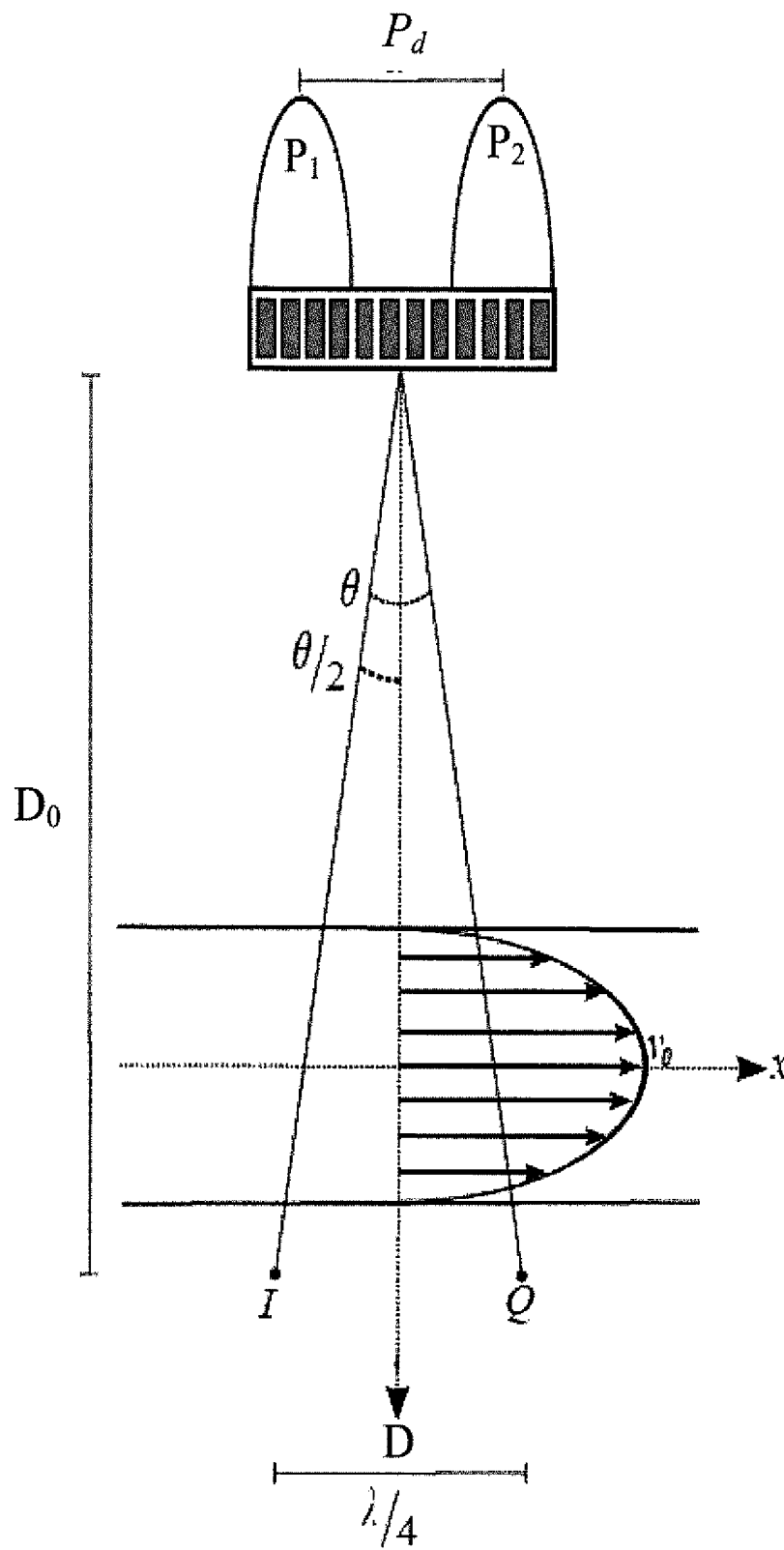

FIGURE 2

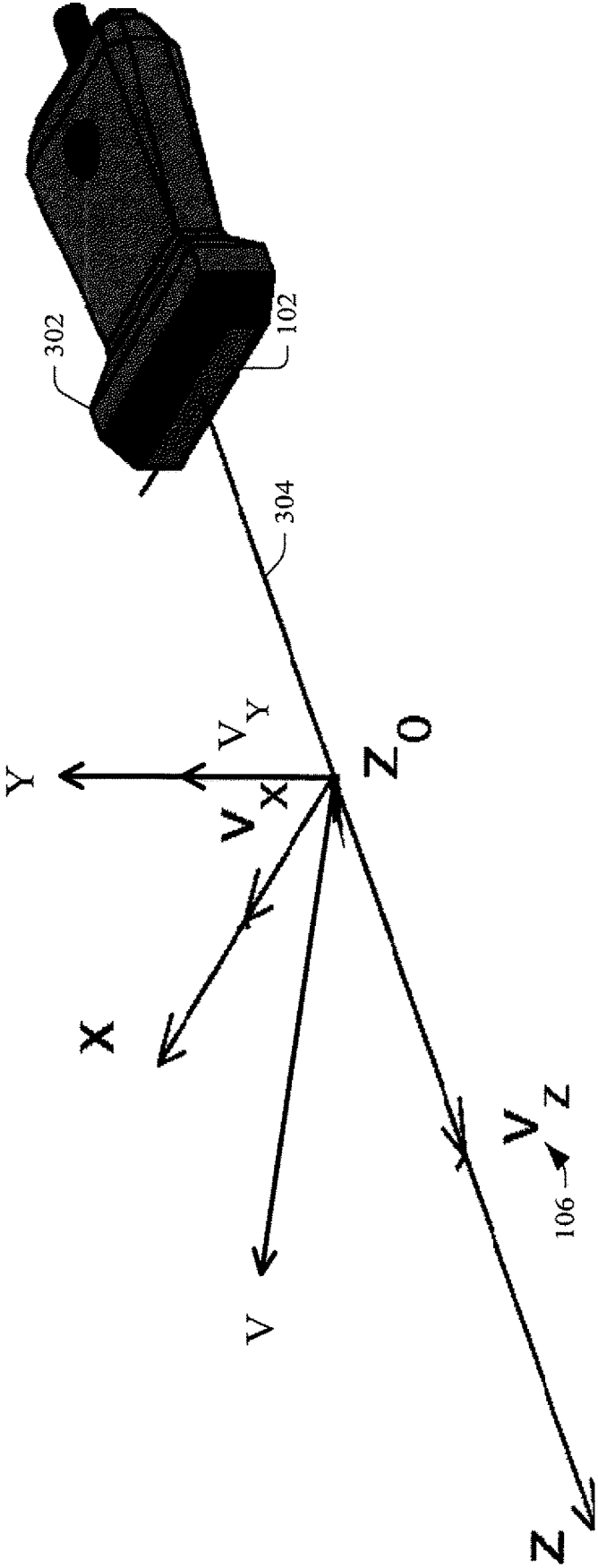

FIGURE 3

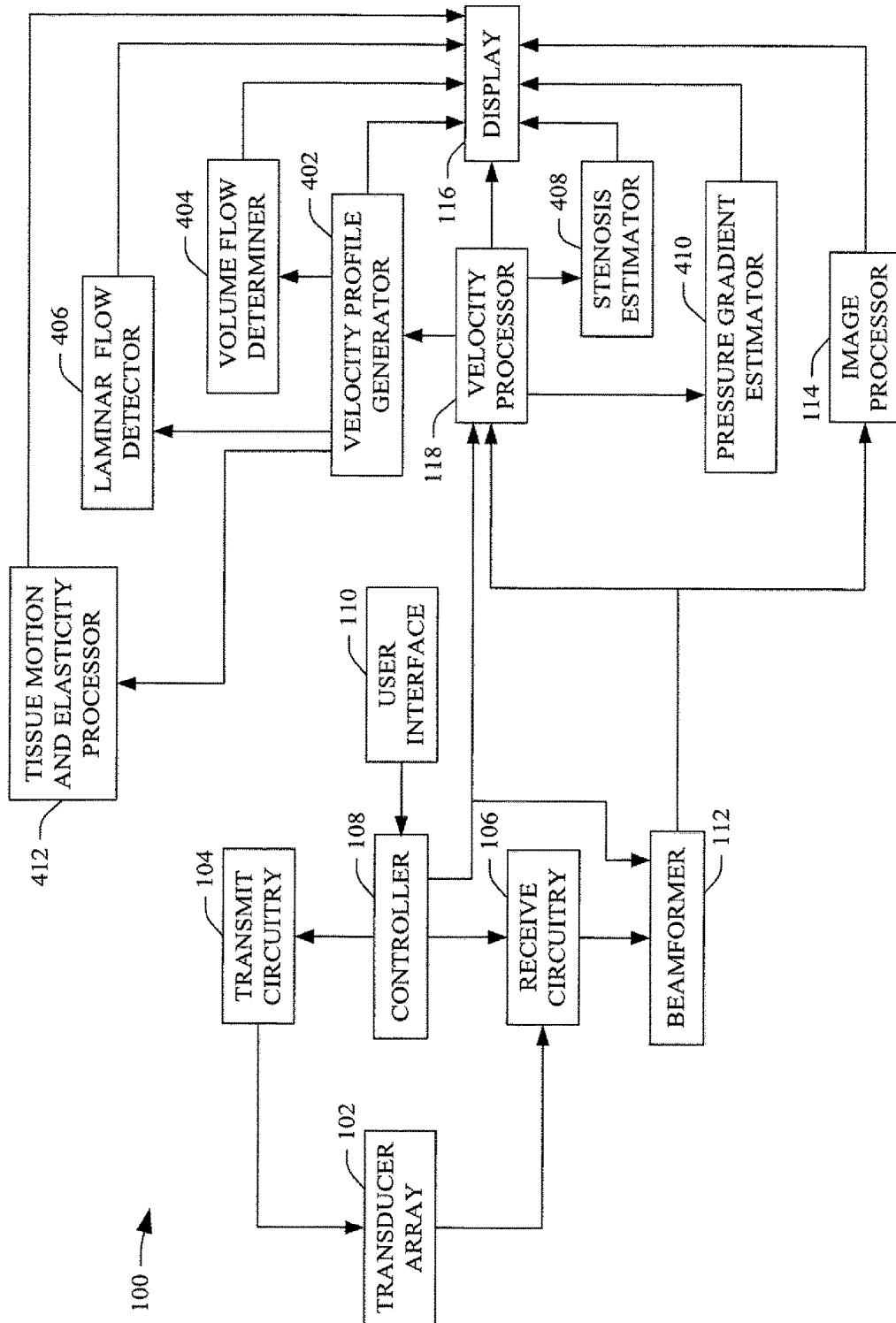

FIGURE 4

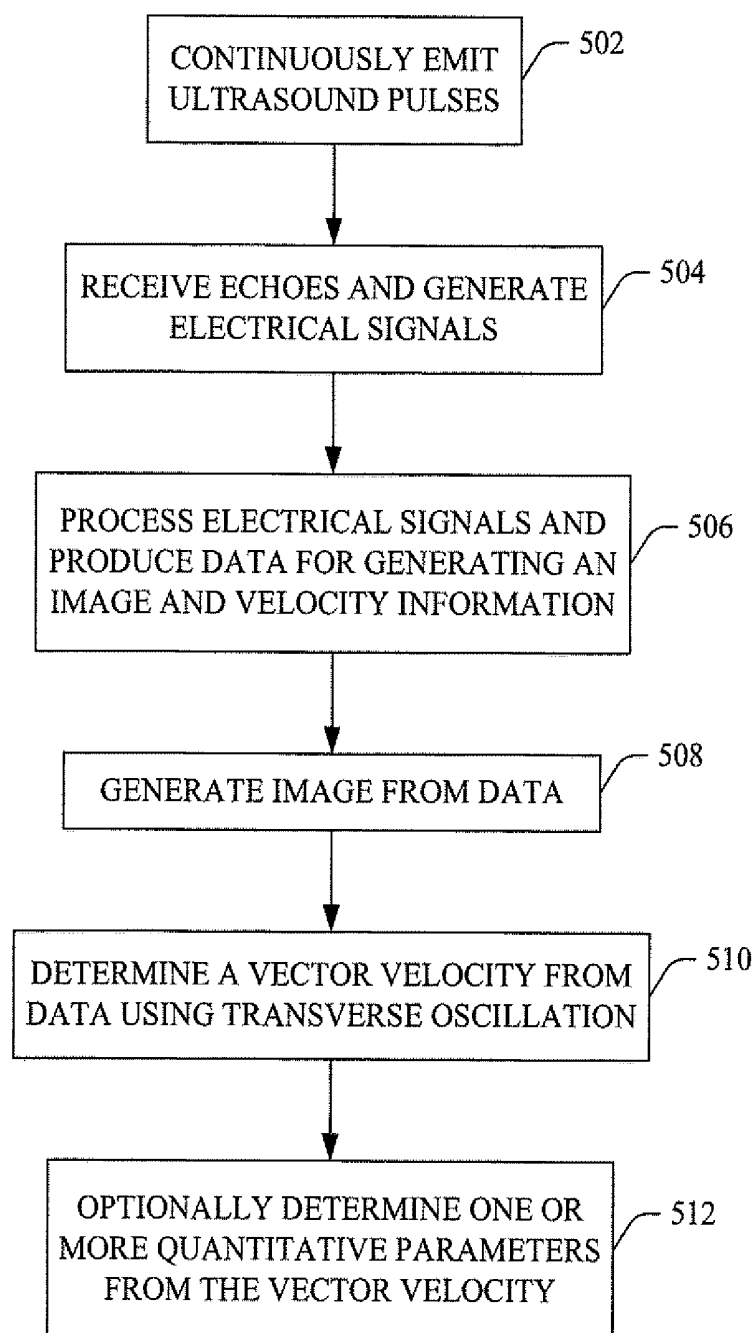

FIGURE 5

TRANSVERSE OSCILLATION VECTOR ESTIMATION IN ULTRASOUND IMAGING

TECHNICAL FIELD

[0001] The following generally relates to ultrasound imaging and more particularly to a transverse oscillation vector velocity estimation in ultrasound imaging.

BACKGROUND

[0002] Ultrasound imaging provides useful information about the interior characteristics of an object or a subject. In one instance, ultrasound imaging is used to generate both an image of the interior characteristics and estimate flow velocity of flowing structure (e.g., blood cells and tissue motion), and display the image with indicia indicative of the estimated flow velocity superimposed there over. An example ultrasound system uses power Doppler or color flow mapping to identify places of flow, and subsequently uses spectral velocity estimation for determining quantitative measures. For this, ultrasound pulses are emitted continuously in one direction and segments of data are Fourier transformed to yield the velocity distribution from which quantitative velocity measures can be found. An example of this is described in Jensen, "Estimation of Blood Velocities Using Ultrasound: A Signal Processing Approach," Cambridge University Press, New York, 1996.

[0003] However, this approach has several drawbacks. For example, with this approach the velocity is only computed in the axial (or beam) direction and must be angle corrected to yield the velocity magnitude. Most often vessels are parallel to the skin surface and the beam-to-flow angle is close to ninety (90) degrees, making the angle correction unreliable and error prone. The spectral estimates also suffer from spectral broadening artifacts from the segmentation and windowing of the data. A consistent over-estimation of peak and mean velocities are therefore often found. Furthermore, the maximum velocity detectable is limited by the pulse repetition frequency and the employed wavelength, which are fixed. This in combination with the length of the segments used gives the lowest velocity detectable and hence the velocity range, which can be estimated during a single measurement.

SUMMARY

[0004] Aspects of the application address the above matters, and others.

[0005] In one aspect, a method includes continuously transmitting, with a transducer array, an ultrasound signal in one direction. The method further includes beamforming, with a beamformer, an echo signal received by the transducer array using on a predetermined apodization function. The echo signal is generated in response to an interaction of the ultrasound signal with flowing structure. The method further includes estimating, with a velocity processor, a vector velocity of the flow, including velocity components, as a function of depth and time from the beamformed echo signals using transverse oscillation vector velocity estimation. The method further includes generating, with a measurement processor, a quantitative measurement from the velocity components. The method further includes visually displaying, with a display monitor, the quantitative measurement.

[0006] In another aspect, an ultrasound imaging system includes a transducer array configured to continuously transmit an ultrasound signal in one direction. The ultrasound imaging system further includes a beamformer configured to beamform echo signals received by the transducer array using on a predetermined apodization function. The ultrasound imaging system further includes a velocity processor configured to determine a vector velocity of flow, including velocity components, from the beamformed echo signals using transverse oscillation vector velocity estimation. The ultrasound imaging system further includes a measurement processor configured to generate a quantitative measurement from the velocity components. The ultrasound imaging system further includes a display that visually presents the quantitative measurement.

[0007] In another aspect, an apparatus includes a beamformer configured to beamform, using on a predetermined apodization function, echo signals received by a transducer array of an ultrasound imaging system. The echo signals are generated in response to an interaction of anatomical tissue and an ultrasound signal continuously transmitted by the transducer array in one direction. The apodization function includes a selectable parameter that controls a maximum measurable velocity. The apparatus further includes a controller that sets the selectable parameter based on whether a first or a second vector velocity is being measured, wherein the first vector velocity is greater than the second vector velocity. The apparatus further includes a processor configured to determine the vector velocity, including velocity components, from the beamformed echo signals using transverse oscillation vector velocity estimation. The apparatus further includes a display that visually presents the quantitative measurement.

[0008] Those skilled in the art will recognize still other aspects of the present application upon reading and understanding the attached description.

BRIEF DESCRIPTION OF THE DRAWINGS

[0009] The application is illustrated by way of example and not limited by the figures of the accompanying drawings, in which like references indicate similar elements and in which:

[0010] FIG. 1 schematically illustrates an example ultrasound imaging system configured for transverse oscillation vector flow imaging (TO VFI);

[0011] FIG. 2 schematically illustrates a transverse oscillation approach for determining a vector velocity, including axial and lateral velocity components, with a 1-D transducer array;

[0012] FIG. 3 schematically illustrates an ultrasound beam and vector velocity components from a scatterer;

[0013] FIG. 4 schematically illustrates a variation of the system of FIG. 1 further configured to make one or more quantitative measurements from the vector velocity; and

[0014] FIG. 5 illustrates a method in accordance with an embodiment disclosed herein.

DETAILED DESCRIPTION

[0015] Initially referring to FIG. 1, an example ultrasound imaging system 100 is illustrated.

[0016] A transducer array 102 includes a one-dimensional (1-D) array or a two dimensional (2-D) array of transducer elements, which are configured to transmit ultrasound sig-

nals, receive echo signals and generate electrical signals indicative of the received echo signals. Examples of 1-D arrays include 16, 32, 64, 128, 256, etc., and examples of 2-D arrays include 32×32, 64×64, etc., 2-D row column matrix arrays and/or other dimension arrays, including circular, elliptical, rectangular, irregular, etc. The transducer array **102** can be linear, curved, and/or otherwise shaped, fully populated, sparse, row-column, etc.

[0017] Transmit circuitry **104** generates a set of pulses that are conveyed to the transducer array **102**. The set of pulses invokes a set of the transducer elements to transmit ultrasound signals. In a continuous emission mode, the set of pulses invokes the transducer array **102** to continuously emit ultrasound signals in one direction. Receive circuitry **106** receives electrical signals from the transducer array **102**, which are indicative of received echoes, which, generally, are a result of the interaction between the transmitted ultrasound signals and the structure such as flowing blood cells, organ cells, soft tissue, etc.

[0018] A controller **108** controls one or more of the transmit circuitry **104** and/or the receive circuitry **106**. Such control can be based on available modes of operation such as the continuous emission with vector velocity estimation as a function of depth using a 2-D or a 3-D transverse oscillation (TO) mode, a B-mode, a measurement mode (e.g., volume flow, pressure gradient, velocity profile, laminar flow, etc.), and/or other mode. Such control can be selected based on one or more signals indicative of input from a user via a user interface (UI) **110**. The UI **110** may include one or more input devices (e.g., a button, a knob, a slider, a touch pad, etc.) and/or one or more output devices (e.g., a display screen, lights, a speaker, etc.).

[0019] A beamformer **112** processes the electrical signals and produces data used to generate at least an image and a vector velocity estimate. For a B-mode image, the beamformer **112** processes the signals by applying time delays, weighting the channels, and summing the weighted delayed signal, and/or otherwise beamforming the signals. For TO vector velocity imaging (VFI), the beamformer **112** beamforms beams to produce spatial lateral in-phase (I) and quadrature (Q) components. An example for 1-D TO is shown in FIG. 2. A transverse oscillation is introduced in the ultrasound field, and this oscillation generates received signals that depend on the transverse oscillation. The basic idea is to create a double-oscillating pulse-echo field and use a particular apodization profile(s) in receive beamforming. The spatial IQ samples, r_1 , r_2 are obtained by $r_1(n)=r_I(n)+jr_Q(n)$ and $r_2(n)=r_I(n)-jr_Q(n)$, where r_I and r_Q are the samples at index n from the left and right beams, respectively. The two beams are phased shifted a quarter of the lateral wavelength. A center beam is beamformed for axial velocity estimation.

[0020] Returning to FIG. 1, an image processor **114** processes the beamformed data and generates a sequence of focused, coherent echo samples along focused scanlines of a scanplane, or a B-mode image. The image processor **114** may also be configured to process the scanlines to lower speckle and/or improve specular reflector delineation via spatial compounding and/or perform other processing such as FIR filtering, IIR filtering, etc. The B-mode image can be displayed via a display **116**. This can be, e.g., in a graphical user interface (GUI), which allows a user to selectively

rotate, scale, manipulate, take measurements on, etc. the displayed data. This can be through a mouse, a keyboard, a touch-screen and/or the like.

[0021] A velocity processor **118** processes the beamformed data to estimate a vector velocity. The velocity processor **118** is configured to determine a vector velocity (v), an axial velocity component (v_z) and a lateral velocity component (v_x) for TO VFI with a 1-D array, and the vector velocity (v), the axial velocity component (v_z), the lateral velocity component (v_x) and an elevation velocity component (v_y) for TO VFI with a 2-D array. Vector velocity components for three dimensions are shown in FIG. 3 in relation to the transducer array **102**, which is housed in and/or part of a probe **302**. FIG. 3 shows v , v_z along a direction of a beam **304**, v_x which is perpendicular to v_z , and v_y which is perpendicular to v_z and v_x .

[0022] Examples of suitable velocity processing are described in U.S. Pat. No. 6,148,224 A, titled “Apparatus and method for determining movements and velocities of moving objects,” and filed Dec. 30, 1998, U.S. Pat. No. 6,859,659 A, titled “Estimation of vector velocity,” and filed May 10, 2000, and patent application US 2014/0257103 A1, titled “Three Dimensional (3D) Transverse Oscillation Vector Velocity Ultrasound Imaging,” and filed Oct. 11, 2011, the entireties of which are all incorporated herein by reference. In general, the velocity components v_x or v_y can be determined as shown below in Equations 4 and 5:

$$v_x = \left(\frac{\lambda_x}{2\pi 2k T_{prf}} \right) \arctan \left(\frac{\mathcal{I}\{R_1(k)\}\mathcal{R}\{R_2(k)\} + \mathcal{J}\{R_2(k)\}\mathcal{R}\{R_1(k)\}}{\mathcal{R}\{R_1(k)\}\mathcal{R}\{R_2(k)\} - \mathcal{J}\{R_2(k)\}\mathcal{J}\{R_1(k)\}} \right), \text{ and} \quad \text{Equation 4}$$

$$v_y = \left(\frac{\lambda_y}{2\pi 2k T_{prf}} \right) \arctan \left(\frac{\mathcal{J}\{R_1(k)\}\mathcal{R}\{R_2(k)\} + \mathcal{J}\{R_2(k)\}\mathcal{R}\{R_1(k)\}}{\mathcal{R}\{R_1(k)\}\mathcal{R}\{R_2(k)\} - \mathcal{J}\{R_2(k)\}\mathcal{J}\{R_1(k)\}} \right), \quad \text{Equation 5}$$

where T_{prf} is the time between two pulses, $R_1(k)$ is the complex lag k autocorrelation value for $r_1(n)$, and $R_2(k)$ is the complex lag k autocorrelation value for $r_2(n)$.

[0023] From the continuous stream of data, the velocity processor **118** continuously estimates a vector velocity via TO VFI. The velocity processor **118** can expand the velocity range and accuracy as described next. For sake of brevity and clarity, the following is described in connection with a 1-D transducer array. However, one of ordinary skill in the art would be able to apply this to application using a 2-D transducer array in view of the description herein and without undue experimentation. Briefly turning back to FIG. 2, the lateral wavelength λ_x can be predicted from Equation 1:

$$\lambda_x = \frac{2\lambda D}{P_d} = \frac{2\lambda D}{N_d P_i}, \quad \text{Equation 1}$$

where X is an axial wavelength, D is a depth, P_d is a distance between peaks P_1 and P_2 in the apodization function, P_i is a transducer pitch, and N_d a number of elements between the peaks P_1 and P_2 . The lateral wavelength λ_x depends on P_d in the receive apodization function.

[0024] In a conventional ultrasound system using an auto-correlation approach, such as the one described in Kasai et al., “Real-Time Two-Dimensional Blood Flow Imaging using an Autocorrelation Technique,” IEEE Trans. Son. Ultrason., 32:458-463, 1985, the maximum detectable velocity v_{max} can be determined as shown in Equation 2:

$$v_{max} = \frac{\lambda f_{prf}}{4} \quad \text{Equation 2}$$

where

$$f_{prf} \left(\text{i.e., } \frac{1}{T_{prf}} \right)$$

is a pulse repetition frequency. For the TO approach described herein, the maximum velocity estimate is determined by the lateral wavelength λ_x and the pulse repetition frequency as shown in Equation 3:

$$v_{max} = \frac{\lambda_x f_{prf}}{4}. \quad \text{Equation 3}$$

[0025] The lateral wavelength λ_x can be changed by changing P_d in Equation 1. For higher velocities, a smaller value of P_d is selected to yield a λ_x four (4) to eight (8) times λ and, thus, yielding a maximum velocity four to eight times larger than in a conventional system. The velocity can also be estimated with a low bias as described in Jensen, “Optimization of transverse oscillating fields for vector velocity estimation with convex arrays,” In Proc. IEEE Ultrason. Symp., pages 1753-1756, July 2013. For lower velocities, a larger value of P_d is selected to make the estimation better as the lateral oscillation period is adapted to low velocity estimation by having a lower λ_x . The variation in P_d is achieved during receive beam forming and set by the controller 108.

[0026] The velocity processor 118 can employ one or more different receive apodization functions to estimate low and high velocities simultaneously from the same data. The velocity processor 118 can also adapt the apodization over time to both yield both high systolic velocities as well as low diastolic velocities for the same data. The velocity processor 118 can also retrospectively change the velocity range automatically and/or with user intervention. This can be combined with directional TO to make itself calibrating and to increase accuracy. An example of directional TO is described in patent application PCT/IB2015/051526, titled “Ultrasound Imaging Flow Vector Velocity Estimation with Directional Transverse Oscillation,” and filed Mar. 2, 2015, the entirety of which is incorporated herein by reference.

[0027] The approach described herein avoids spectral broadening seen in spectral estimates from windowing, allowing for yielding truly quantitative data with automatic angle estimation, as both the axial and transverse velocities are estimated. The same data can also be processed to simultaneously compute and display the TO velocity, a spectrogram, and a transverse spectrogram as discussed in patent application US 20150331103 A1, titled “Angle independent velocity spectrum determination,” and filed Nov.

28, 2012, the entirety of which is incorporated herein by reference, and in Jensen, “Transverse spectral velocity estimation,” IEEE Trans. Ultrason., Ferroelec., Freq. Contr., 61(11):1815-1823, November 2014.

[0028] FIG. 4 shows a variation in which the system 100 of FIG. 1 further includes a velocity profile generator 402. The velocity processor 314 estimates velocities as a function of depth and time as data are measured continuously along the measurement direction. The velocity profile generator 402 processes this data and generate a velocity profile. The velocity profile is then displayed as arrows superimposed on the B-mode image, in other time-depth-velocity displays, etc. The velocity profile generator 402 can compute and display a velocity magnitude and/or an angle as a function of time or depth from the velocity profile.

[0029] FIG. 4 further includes a volume flow determiner 404 which directly calculate the volume flow for a vessel from the velocity profile. For this, boundaries of a vessel are marked or estimated on the B-mode image, and a center position of the vessel is determined, automatically and/or manually by a user. Assuming a circular vessel, the volume flow Q is found by integrating the velocities weighted by the area at the give depth as show in Equation 6:

$$Q = \pi \Delta r \sum_{n=-N/2}^{N/2} |n| \vec{v}(n) \cdot \vec{e}, \quad \text{Equation 6}$$

where Δr is the radial sampling interval, N is the number of intervals within the vessel, $\vec{v}(n)$ is the velocity at sample n, and \vec{e} is the unit vector for the plane to find the volume flow through. An elliptical vessel dimensions can be determined from the B-mode image perpendicular to the velocity view to find a major axis d_2 and a minor axis d_1 . The volume flow is then computed by as shown in Equation 7:

$$Q = \frac{d_2}{d_1} \pi \Delta r \sum_{n=-N/2}^{N/2} |n| \vec{v}(n) \cdot \vec{e}. \quad \text{Equation 7}$$

[0030] FIG. 4 further includes a laminar flow detector 406 that can detect presence and/or absence of laminar flow from the velocity angle determined by the velocity profile generator 402. Generally, a stable angle over time shows that laminar flow is present, and deviations from the mean angle is an indication of disturbed or turbulent flow. The angle for a fully turbulent flow will randomly fluctuate between $-\pi$ to $+\pi$ with a rectangular probability density, which has a variance of

$$\sigma_{\theta}^2 = \frac{(2\pi)^2}{12} = \frac{\pi^2}{3}.$$

An index L_i for indicating whether the flow is laminar is as shown in Equation 8:

$$L_i = 1 - \sqrt{\frac{\hat{\sigma}_\theta^2}{\frac{\pi^2}{3}}} = 1 - \sqrt{\frac{\frac{1}{N} \sum_{n=1}^{N_\theta} (\hat{\theta}(n) - E\{\hat{\theta}(n)\})^2}{\frac{\pi^2}{3}}} \quad \text{Equation 8}$$

where θ is the beam to flow angle, $\hat{\theta}(n)$ is the velocity angles estimate, $\hat{\sigma}_\theta^2$ is the estimated angle variance, and $E\{\}$ denotes mean value, and N_θ is the number of estimates averaged over in either time or space or both. A value of one (1) indicates a fully laminar flow with no angle variation, whereas a value of zero (0) is for fully turbulent flow. The index can be found over time and averaged, averaged over space, etc. It can also be used for displaying a turbulence map.

[0031] FIG. 4 further includes a stenosis estimator 408. The stenosis estimator 408 can determine a degree of stenosis in a vessel from a ratio between vector velocities measured before and at the stenosis. The approach described herein has a higher maximum velocity than for spectral estimation and can measure at two different places intermixed, and still have a sufficient velocity range for making a reliable index. The beams are placed at the stenosis and before it, and the velocity ratio is determined.

[0032] In one instance, the stenosis estimator 408 determines the stenosis degree as shown in Equation 9:

$$s_d = 1 - \sqrt{\frac{r_1}{r_2}} \quad \text{Equation 9}$$

where r_1 is a radius at the stenosis and r_2 is a radius at the non-stenosed part of the vessel. Assuming a parabolic velocity profile the stenosis degree can be determined as shown in Equation 10:

$$s_d = 1 - \sqrt{\frac{v_1}{v_2}} \quad \text{Equation 10}$$

where v_1 is a velocity measured at the stenosis and v_2 is a velocity measured at the non-stenosed part of the vessel. The velocities can be the mean, peak, instantaneous and/or other velocity and/or averaged values of these over time and/or space. The stenosis degree is estimated as shown in Equation 11:

$$s_d = 1 - \sqrt{\frac{v_2}{2v_1}} \quad \text{Equation 11}$$

if a plug flow is assumed in the vessel. The flow type (parabolic/plug or in between) can be determined from the velocity profile measured by the approach described.

[0033] FIG. 4 further includes a pressure gradient estimator 410. The pressure gradient estimator 410 can determine pressure gradients in vessels by solving the Navier-Stokes equation and determining and using temporal and spatial

acceleration of the flow. These can be derived from sending out a broad beam in transmit and then focus around two directions in receive. This will give data suitable for both deriving the temporal and spatial accelerations due to the continuous acquisition. The spatial acceleration is derived based on velocity estimates from both the two adjacent beams and the estimates as a function of depth to yield spatial accelerations in two directions.

[0034] Examples are described in Jensen et al., "Accuracy and sources of error for an angle independent volume flow estimator," Proc. IEEE Ultrason. Symp., pages 1714-1717, Olesen et al., "Noninvasive estimation of 2-D pressure gradients in steady flow using ultrasound," IEEE Trans. Ultrason., Ferroelec., Freq. Contr., patent application PCT/IB2015/054246, titled "Non-invasive Estimation of Intravascular Pressure Changes using Vector Velocity Ultrasound (US)," and filed Jun. 4, 2015, the entirety of which is incorporated herein by reference, and patent application PCT/IB2015/055592, titled "Flow Acceleration Estimation Directly From Beamformed Ultrasound Data," and filed Jul. 23, 2015, the entirety of which is incorporated herein by reference.

[0035] FIG. 4 further includes a tissue motion and elasticity processor 412. The tissue motion and elasticity processor 412 can be employed to both estimate velocities in blood vessel or in the surround tissue to quantify tissue motion from the velocity profile. An example of estimating these parameters from a velocity measurement is as described by Anderson, T., & McDicken, W. N. (1999). Measurement of tissue motion. Proceedings of the Institution of Mechanical Engineers, Journal of Engineering in Medicine, Archive, Proceedings of Institution of Mechanical Engineers, Part H, 213(H3), 181-191. Additionally or alternatively, the tissue motion and elasticity processor 412 can also be used to quantify the elasticity of tissue from the velocity profile. An example of quantifying this parameter from a velocity measurement is described in Ophir et al. "Elastography: Imaging the Elastic Properties of Soft Tissues with Ultrasound.", J. Med. Ultrason 29.4 (2002): 155-171.

[0036] It is to be appreciated that one or more of the velocity profile generator 402, the stenosis estimator 408 or the pressure gradient estimator 410 can be omitted. Where the velocity profile generator 402 is omitted, the volume flow determiner 404, the laminar flow detector 406 and the tissue motion and elasticity processor 412 are omitted. Where the velocity profile generator 402 is present, the volume flow determiner 404, the laminar flow detector 406 and/or the tissue motion and elasticity processor 412 are present (or omitted). A combination of one or more of the components 402, 404, 406, 408, 410 and 412 is referred to herein as a measurement processor.

[0037] It is also to be appreciated that one or more of the velocity processor 118, the velocity profile generator 402, the volume flow determiner 404, the laminar flow detector 406, the stenosis estimator 408, or the pressure gradient estimator 410 can be implemented by a processor (e.g., a central processing unit, a microprocessor, etc.) executing a computer readable instruction embedded or stored on non-transitory computer readable medium (which excludes transitory computer readable medium) such as physical memory and/or carried by transitory computer readable medium such as a carrier wave, signal, etc.

[0038] The ultrasound imaging system 100 can be part of a portable system on a stand with wheels, a system residing on a tabletop, and/or other system in which the transducer array 102 is housed in a probe or the like, and a console is housed in an apparatus separate therefrom. In another instance, the transducer array 102 and the console can be housed in a same apparatus such as within a single enclosure hand-held ultrasound scanning device.

[0039] FIG. 5 illustrates an example method for employing the ultrasound imaging system.

[0040] It is to be understood that the following acts are provided for explanatory purposes and are not limiting. As such, one or more of the acts may be omitted, one or more acts may be added, one or more acts may occur in a different order (including simultaneously with another act), etc.

[0041] At 502, ultrasound pulses are continuously emitted by the transducer array 102.

[0042] At 504, echoes, in response to the ultrasound signal, are received by the transducer array 102, and electrical signals indicative of the echoes are generated.

[0043] At 506, the electrical signals are processed to produce data for generating an image and for determining velocity via TO.

[0044] At 508, an image is generated with the data, as described herein and/or otherwise.

[0045] At 510, flow velocity is determined with the data, as described herein and/or otherwise. This includes setting a maximum measurable velocity, adjust the maximum measurable velocity range, concurrently measuring velocities, etc.

[0046] At 512, optionally, one or more quantitative measurements are determined based on the flow velocity, as described herein and/or otherwise.

[0047] The methods described herein may be implemented via one or more processors executing one or more computer readable instructions encoded or embodied on computer readable storage medium such as physical memory, which causes the one or more processors to carry out the various acts and/or other functions and/or acts. Additionally or alternatively, the one or more processors can execute instructions carried by transitory medium such as a signal or carrier wave.

[0048] The approach described herein is an improvement in the technology. The approach emits continuously in one direction, which yields continuous vector flow data, generated via TO VFI, which is used to determine one or more quantitative measurements such as velocity magnitudes, directions and/or profiles, and/or flow volume, flow turbulence and/or rotation, flow accelerations, pressure gradients, degrees of stenosis, and/or other quantitative measures. It also allows for measuring larger velocities than for spectral systems, which allows for a larger span of velocities to estimate than for traditional spectral techniques. It can replace the spectral display with much more accuracy and avoids errors from both the velocity angle and spectral broadening. The combination of function herein includes unconventional steps that confine the claim to a particular useful application.

[0049] The application has been described with reference to various embodiments. Modifications and alterations will occur to others upon reading the application. It is intended that the invention be construed as including all such modi-

fications and alterations, including insofar as they come within the scope of the appended claims and the equivalents thereof.

What is claimed is:

1. A method, comprising:

continuously transmitting, with a transducer array, an ultrasound signal in one direction;

beamforming, with a beamformer, an echo signal received by the transducer array using on a predetermined apodization function, wherein the echo signal is generated in response to an interaction of the ultrasound signal with flowing structure;

estimating, with a velocity processor, a vector velocity of the flow, including velocity components, as a function of depth and time from the beamformed echo signals using transverse oscillation vector velocity estimation;

generating, with a measurement processor, a quantitative measurement from the velocity components; and visually displaying, with a display monitor, the quantitative measurement.

2. The method of claim 1, further comprising:

generating a B-mode image from the beamformed echo signals; and

displaying the B-mode image with graphical indicia representing the quantitative measurement overlaid over the B-mode image.

3. The method of claim 1, where the transducer array is a 1-D array and the velocity components include an axial velocity component and a lateral velocity component.

4. The method of claim 1, where the transducer array is a 2-D array and the velocity components include an axial velocity component, a lateral velocity component and an elevation velocity component.

5. The method of claim 1, further comprising:

estimating a maximum velocity based on

$$v_{max} = \frac{\lambda_x f_{prf}}{4},$$

where v_{max} is the maximum velocity, λ_x is a lateral wavelength, and f_{prf} is a pulse repetition frequency.

6. The method of claim 5, further comprising:

adjusting a range of the maximum velocity by changing a distance between peaks in the apodization function.

7. The method of claim 1, wherein the apodization function includes a first apodization function and a second different apodization function, and further comprising:

concurrently estimating a first velocity using the first apodization function and estimating a second velocity using the second different apodization function.

8. The method of claim 1, further comprising:

adjusting a parameter of the apodization function over time to generate both a high systolic velocity and a low diastolic velocity from the same data.

9. The method of claim 1, further comprising:

determining a velocity profile from the velocity components along a measurement direction.

10. The method of claim 9, further comprising:

determining a volume flow from the velocity profile.

11. The method of claim 9, further comprising:

determining a presence or absence of laminar flow from the velocity profile.

- 12.** The method of claim **1**, further comprising:
determining a first velocity before a stenosis in a vessel;
determining a second velocity at the stenosis in the vessel;
and
determining a degree of stenosis in a vessel from a ratio
of the first velocity to the second velocity.
- 13.** The method of claim **1**, further comprising:
determining a temporal acceleration of flow and a spatial
acceleration of flow from the velocity; and
determining a pressure gradient in a vessel by solving the
Navier-Stokes equation using the temporal acceleration
of flow and the spatial acceleration of flow.
- 14.** An ultrasound imaging system, comprising:
a transducer array configured to continuously transmit an
ultrasound signal in one direction;
a beamformer configured to beamform echo signals
received by the transducer array using on a predeter-
mined apodization function;
a velocity processor configured to determine a vector
velocity of flow, including velocity components, from
the beamformed echo signals using transverse oscillation
vector velocity estimation;
a measurement processor configured to generate a quan-
titative measurement from the velocity components;
and
a display that visually presents the quantitative measure-
ment.
- 15.** The system of claim **14**, where the velocity compo-
nents are from a group consisting of an axial velocity
component, a lateral velocity component and an elevation
velocity component.
- 16.** The method of claim **13**, further comprising:
a controller that determines a maximum velocity mea-
sureable range by changing a lateral wavelength by
changing a distance between peaks in the apodization
function, wherein the maximum velocity is on an order
of four to eight times a maximum velocity determined
from an axial wavelength.
- 17.** The system of claim **14**, wherein the measurement
processor determines a velocity profile from the vector
velocity.
- 18.** The system of claim **14**, wherein the display displays
the velocity profile as arrows superimposed on a B-mode
image.
- 19.** The system of claim **17**, wherein the measurement
processor determines a volume flow for a vessel directly
from the velocity profile.
- 20.** The system of claim **17**, wherein the measurement
processor determines a velocity magnitude as a function of
time or depth from the vector velocity from the velocity
profile.
- 21.** The system of claim **17**, wherein the measurement
processor determines a velocity angle as a function of time
or depth from the vector velocity from the velocity profile.
- 22.** The system of claim **21**, wherein the measurement
processor detects a presence of laminar flow from the
velocity angle as a function of time, wherein a stable angle
over time indicates laminar flow.
- 23.** The system of claim **21**, wherein the measurement
processor detects an absence of laminar flow from the
velocity angle as a function of time, wherein deviations from
a mean of the angle indicates turbulent flow.
- 24.** The system of claim **14**, wherein the measurement
processor determines a degree of stenosis in a vessel from a
ratio between vector velocities measured before and at a
stenosis.
- 25.** The system of claim **14**, wherein the measurement
processor determines a pressure gradient in a vessel by
solving the Navier-Stokes equation the vector velocity.
- 26.** An apparatus, comprising:
a beamformer configured to beamform, using on a pre-
determined apodization function, echo signals received
by a transducer array of an ultrasound imaging system,
wherein the echo signals are generated in response to
an interaction of anatomical tissue and an ultrasound
signal continuously transmitted by the transducer array
in one direction, wherein the apodization function
includes a selectable parameter that controls a maxi-
mum measurable velocity;
a controller that sets the selectable parameter based
whether a first or a second vector velocity is being
measured, wherein the first vector velocity is greater
than the second vector velocity;
a processor configured to determine the vector velocity,
including velocity components, from the beamformed
echo signals using transverse oscillation vector velocity
estimation; and
a display that visually presents the quantitative measure-
ment.
- 27.** The apparatus of claim **26**, wherein the controller
adapts the parameter over time to generate both a high vector
velocity and a low vector velocity from the same data.
- 28.** The apparatus of claim **26**, wherein the apodization
function includes a first apodization function and a second
different apodization function, and the controller sets a first
parameter value for the first apodization function and a
second parameter value for the second apodization function
to concurrently determine first and second different vector
velocities.
- 29.** The apparatus of claim **26**, further comprising:
a measurement processor configured to generate a quan-
titative measurement from the velocity components.

* * * * *

专利名称(译)	超声成像中的横向振荡矢量估计		
公开(公告)号	US20170245833A1	公开(公告)日	2017-08-31
申请号	US15/054339	申请日	2016-02-26
[标]申请(专利权)人(译)	B-K医疗公司		
申请(专利权)人(译)	B-k医疗APS		
当前申请(专利权)人(译)	B-k医疗APS		
[标]发明人	JENSEN JORGEN		
发明人	JENSEN, JORGEN		
IPC分类号	A61B8/08 A61B8/06 A61B8/00 G01S7/52 A61B8/14		
CPC分类号	A61B8/5223 G01S7/52085 A61B8/06 A61B8/463 A61B8/5207 A61B8/145 G01S7/52042 G01S15/8927 G01S15/8984 G01S15/8993 G16H50/30		
其他公开文献	US10448926		
外部链接	Espacenet	USPTO	

摘要(译)

一种方法包括利用换能器阵列在一个方向上连续发送超声信号。该方法还包括利用波束形成器利用预定的切趾函数对换能器阵列接收的回波信号进行波束形成。响应于超声信号与流动结构的相互作用而产生回波信号。该方法还包括利用速度处理器使用横向振荡矢量速度估计来估计流的矢量速度，包括速度分量，作为来自波束形成的回波信号的深度和时间的函数。该方法还包括利用测量处理器从速度分量生成定量测量。该方法还包括用显示监视器可视地显示定量测量。

