



US 20070167781A1

(19) **United States**

(12) **Patent Application Publication**  
**Vortman et al.**

(10) **Pub. No.: US 2007/0167781 A1**  
(43) **Pub. Date: Jul. 19, 2007**

(54) **HIERARCHICAL SWITCHING IN  
ULTRA-HIGH DENSITY ULTRASOUND  
ARRAY**

**Publication Classification**

(75) Inventors: **Kobi Vortman**, Haifa (IL); **Yoav  
Medan**, Haifa (IL); **Avner Ezion**, Haifa  
(IL)

(51) **Int. Cl.**  
*A61B 8/00* (2006.01)  
(52) **U.S. Cl.** ..... **600/443**

Correspondence Address:  
**VISTA IP LAW GROUP LLP**  
**12930 Saratoga Avenue**  
**Suite D-2**  
**Saratoga, CA 95070 (US)**

(57) **ABSTRACT**

A focused ultrasound system comprises a transducer having a multiplicity of transducer elements, drive circuitry that generates and outputs a plurality of drive signals, each offset by a respective phase difference, and a controller for selectively coupling the drive signals to respective transducer elements, the controller including a plurality of first tier switching modules and second tier switching modules. Each first tier module receives as an input the plurality of drive signals and outputs one of the drive signals in response to a drive signal selection signal. Each second tier module is coupled to a respective grouping of transducer elements and selectively couples a respective selected drive signal output from a first tier switching module to one or more of the transducer elements in response to a transducer element selection signal.

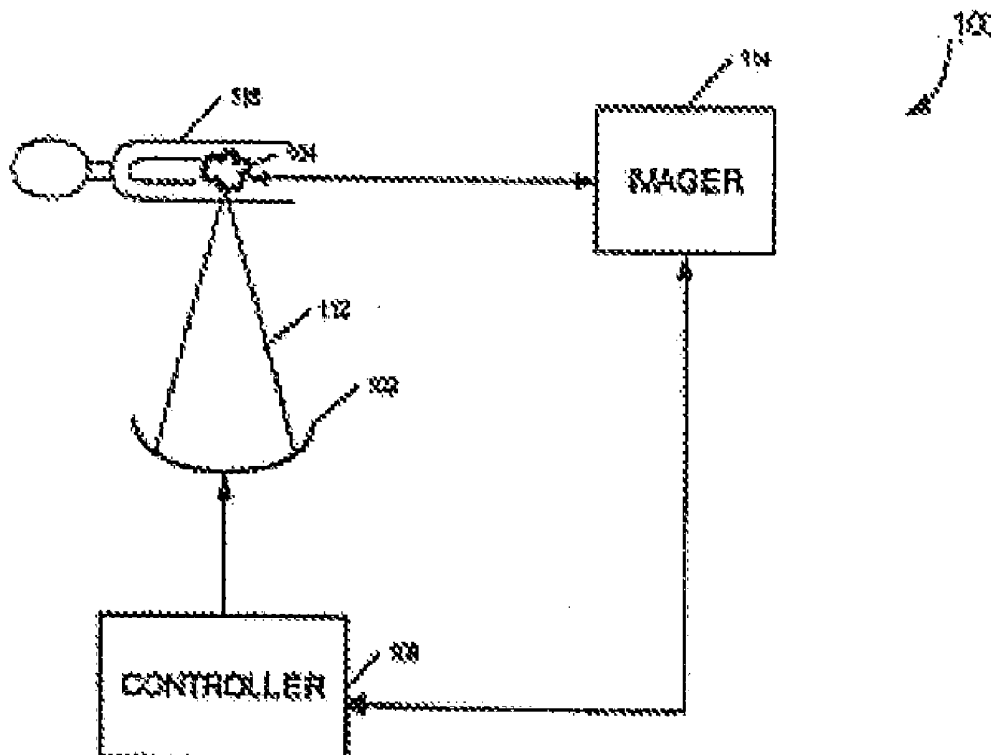
(73) Assignee: **INSIGHTEC LTD.**, Tirat Carmel (IL)

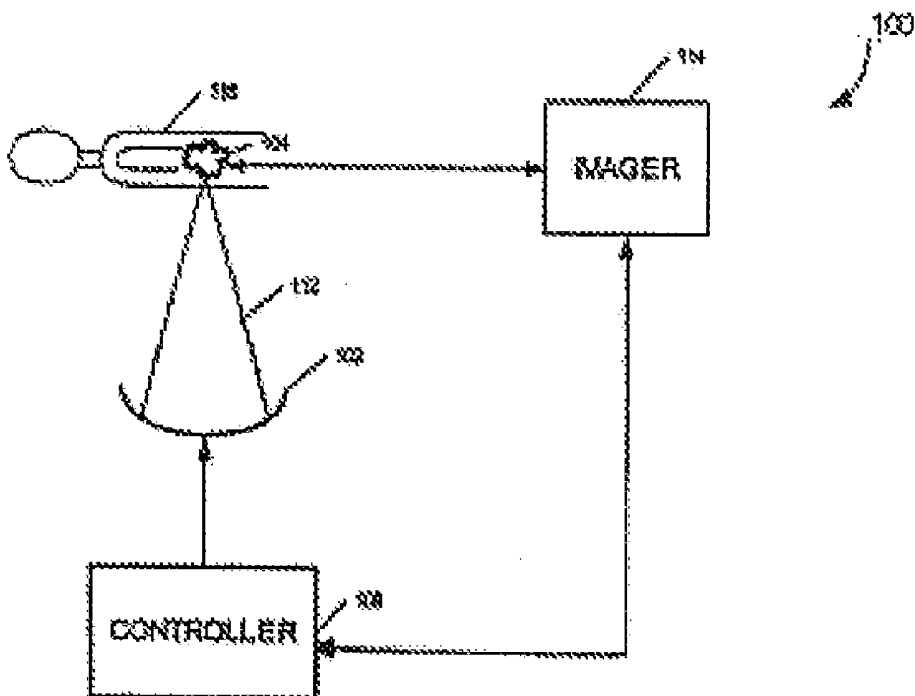
(21) Appl. No.: **11/562,749**

(22) Filed: **Nov. 22, 2006**

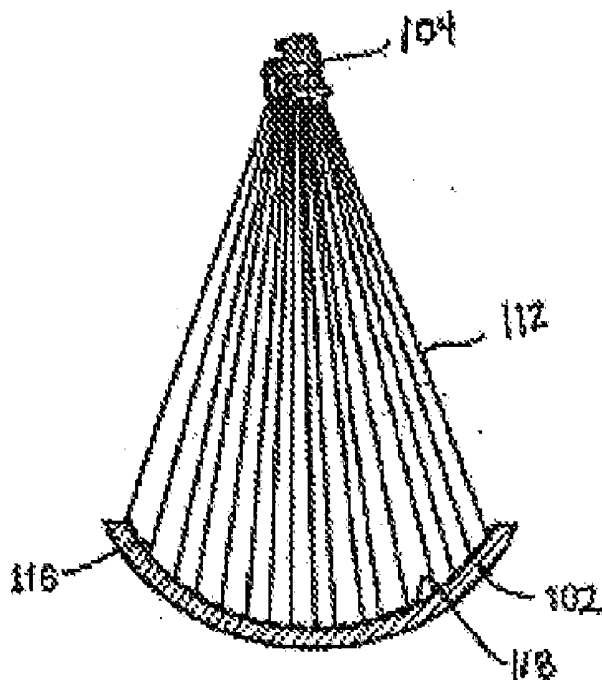
**Related U.S. Application Data**

(60) Provisional application No. 60/739,862, filed on Nov. 23, 2005.

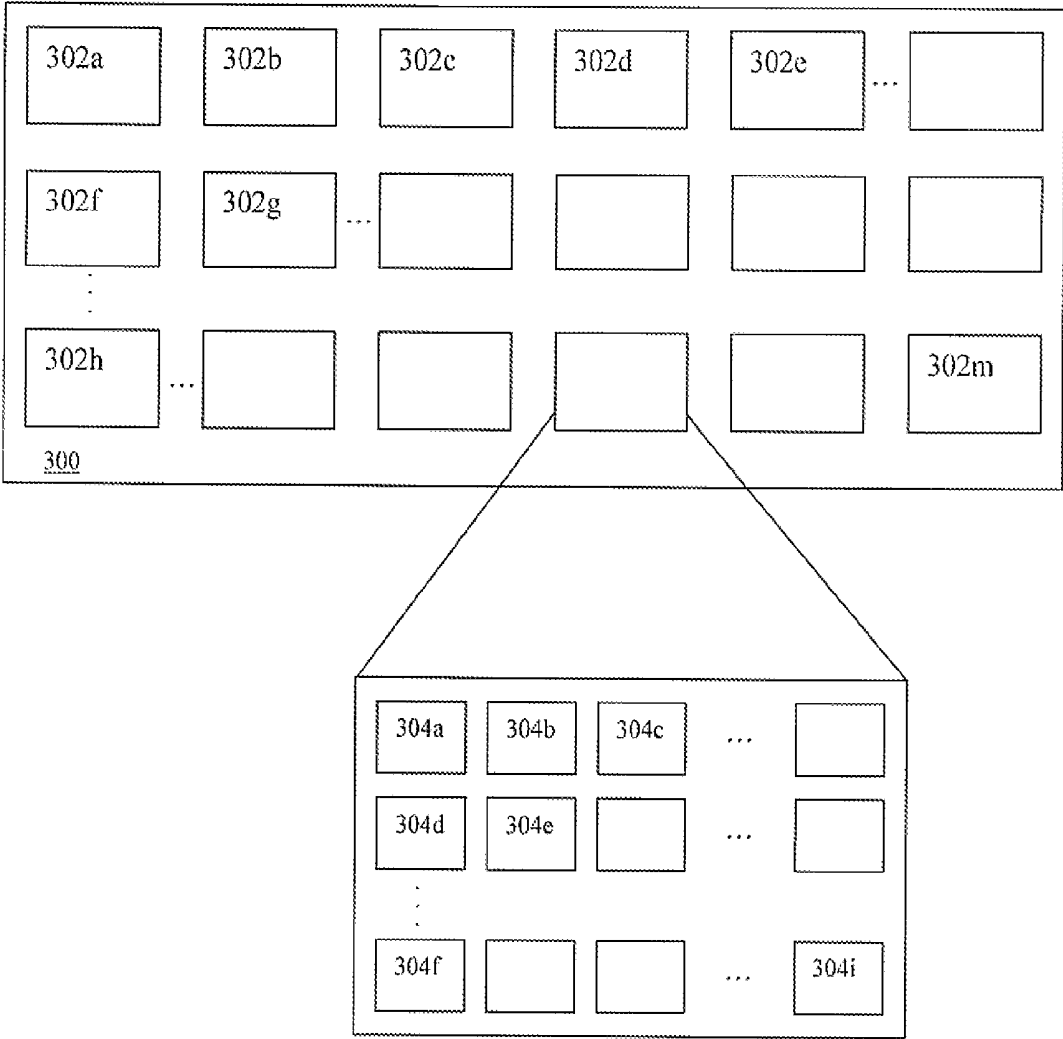




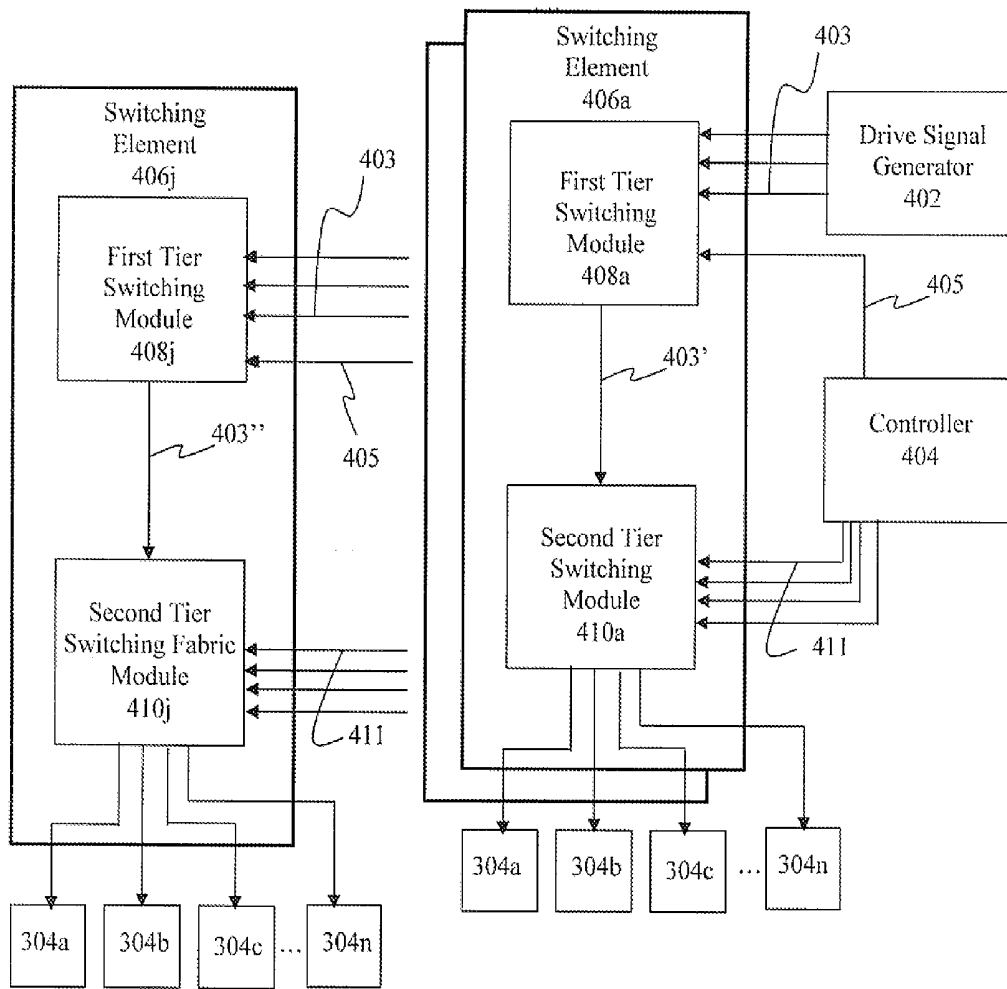
**FIGURE 1**



**FIGURE 2**

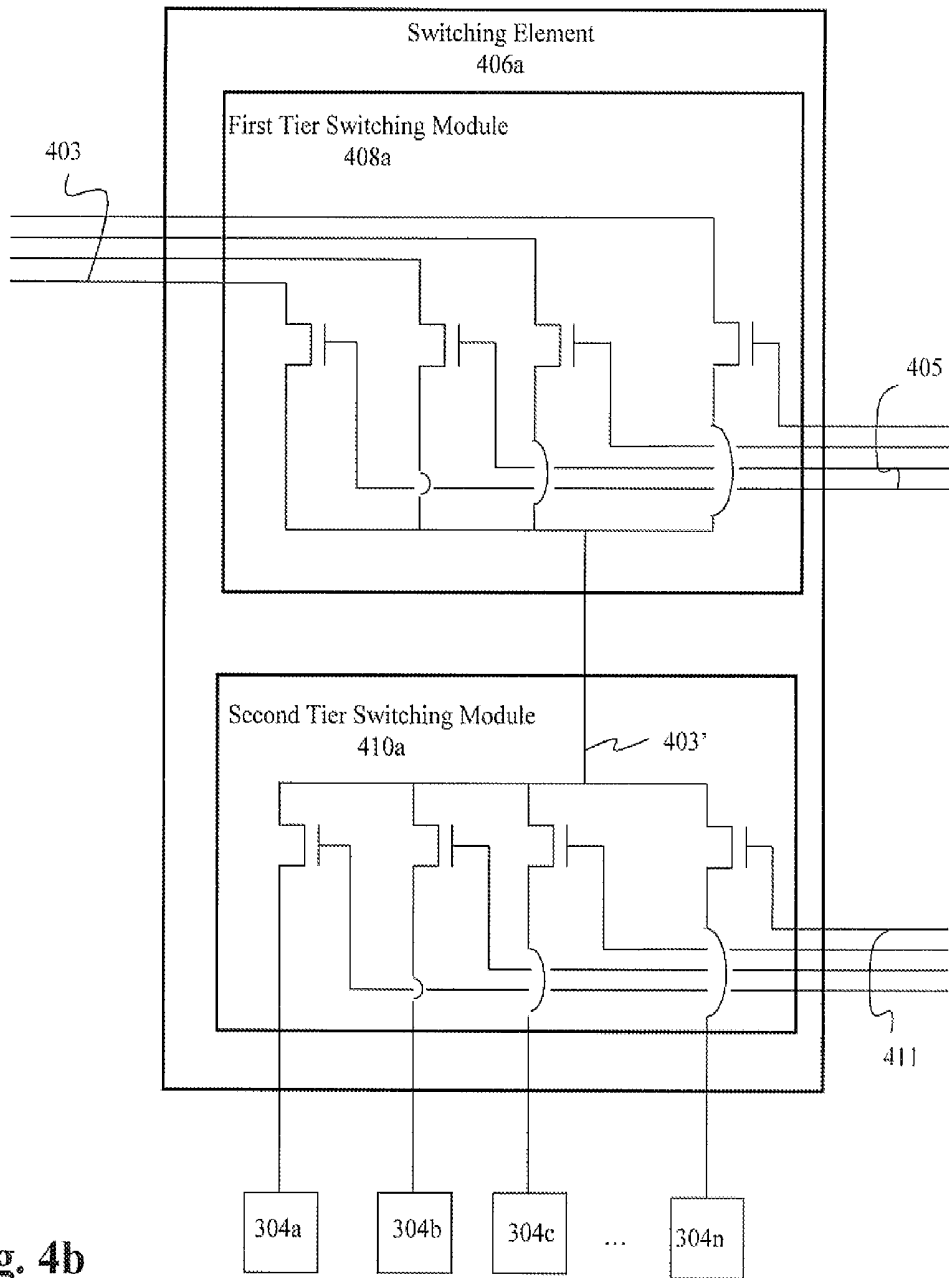


**Fig. 3**

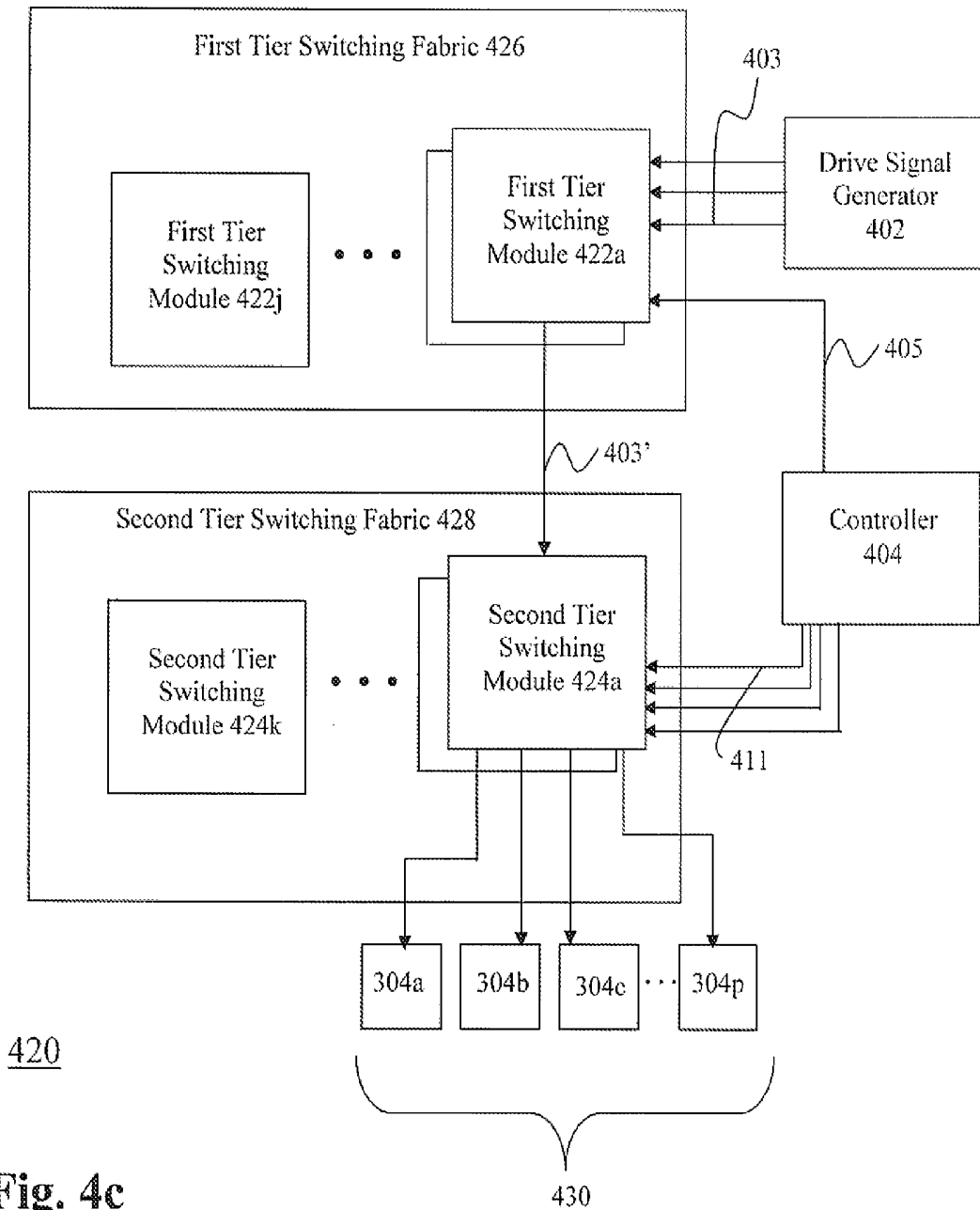


400

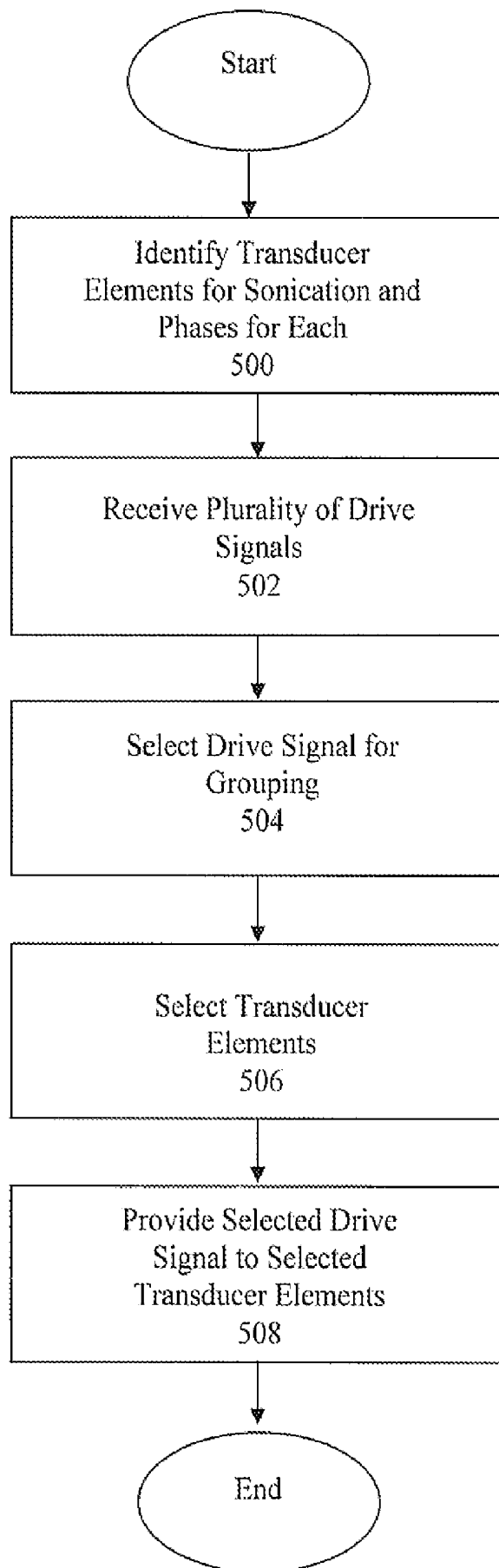
**Fig. 4a**



**Fig. 4b**



**Fig. 4c**



**Fig. 5**

## HIERARCHICAL SWITCHING IN ULTRA-HIGH DENSITY ULTRASOUND ARRAY

### RELATED APPLICATION DATA

[0001] The present application claims the benefit under 35 U.S.C. § 119 to U.S. provisional patent application Ser. No. 60/739,862, filed Nov. 23, 2005, which is hereby incorporated by reference.

### FIELD OF INVENTION

[0002] This application relates generally to systems for delivering high intensity, therapeutic acoustic energy from a multi-element transducer, e.g., a high density, phased-array transducer, to a targeted tissue region in a patient.

### BACKGROUND

[0003] It is well-known to use high intensity, focused acoustic wave energy, such as ultrasonic waves (i.e., acoustic waves having) a frequency greater than about 20 kilohertz, to generate thermal ablation energy for treating internal body tissue, such as tumors. It is also well-known to employ an imaging system, such as a MRI system, in order to (guide the delivery of such high intensity ultrasound energy to the targeted tissue area, and to provide real-time feedback of the actual delivered thermal energy. One Such image-guided, focused ultrasound system is the Exablate® 2000 system manufactured and distributed by InSightec Ltd, located in Haifa, Israel (www.Insightec.com). By way of illustration, FIG. 1 is a simplified schematic representation of an image-guided, focused ultrasound system 100 used to generate and deliver a focused acoustic energy beam 112 to a targeted tissue mass 104 in a patient 110. The system 100 employs an ultrasound transducer 102 that is geometrically shaped and physically positioned relative to the patient 110 in order to focus the ultrasonic energy beam 112 at a three-dimensional focal zone located within the targeted tissue mass 104. The transducer 102 may be substantially rigid, semi-rigid, or substantially flexible, and can be made from a variety of materials, such as plastics, polymers, metals, and alloys. The transducer 102 can be manufactured as a single unit, or alternatively, be assembled from a plurality of components. While the illustrated transducer 102 has a "spherical cap" shape, a variety of other geometric transducer shapes and configurations may be employed to deliver a focused acoustic beam, including linear (planar) configurations. The ultrasound system 100 may further include a coupling membrane (not shown), such as an inflatable body or a balloon filled with degassed water, for providing or improving the acoustic coupling between the transducer 102 and the skin surface of the patient 110.

[0004] The transducer 102 may be formed of relatively large number of individually controlled elements 116 mounted on a distal (outward) facing surface 118 (best seen in FIG. 2) of the transducer 102. Each transducer element 116 may itself comprise one or more (adjacent) piezoelectric members electrically connected to a same drive signal supplied from a system controller 106. During operation, the individual piezoelectric members each contribute a fractional part of the ultrasound energy beam 112 by converting the respective electronic drive signal into mechanical motion and resulting wave energy. The wave energy transmitted from the individual piezoelectric members of the transducer

elements 116 collectively forms the acoustic energy beam 112, as the respective waves converge at the focal zone in the targeted tissue mass 104. Within the focal zone, the wave energy of the beam 112 is absorbed (i.e., attenuated) by the tissue, thereby generating heat and raising the temperature of the tissue to a point where the cells are denatured ("ablated").

[0005] An imager (e.g., an MRI system) 114 is used to generate three-dimensional images of the targeted tissue mass 104 before, during, and after the wave energy is delivered. The images are thermally sensitive so that the actual thermal dosing boundaries (i.e., the geometric boundaries and thermal gradients) of the ablated tissue may be monitored. The location, shape, and intensity of the focal zone of the acoustic beam 112 is determined, at least in part, by the physical arrangement of the transducer elements 116 and the physical positioning of the transducer 102. The location, shape, and intensity of the focal zone may also be controlled, at least in part, by controlling the respective output (e.g., phase and amplitude) of the individual transducer elements 116 by a process known as "electronic steering" of the beam 112. Examples of such physical positioning systems and techniques, and of electronic beam steering, including driving and controlling the output of individual transducer elements, can be found in U.S. Pat. Nos. 6,506,154, 6,506,171, 6,582,381, 6,613,004 and 6,618,620, which are all incorporated by reference herein.

[0006] In order to accommodate variations in treatment procedures and to access interior body regions that are difficult if not impossible to treat with a more conventional, e.g., spherical cap, ultrasound transducer, it may be desirable to employ an ultra-dense transducer array containing a relatively large number of individual elements. Although each element is preferably relatively small, such as on the order of the wavelength of the acoustic energy transmitted, given the large number of available elements, it would only be necessary to activate a relatively small subset of such elements in order to deliver a sufficient amount of acoustic energy to the focal zone. However, individual drive signals would still have to be provided to each transducer element in order for the transducer element to transmit energy, and it would still be desirable to be able to activate any given element with any one of a number of possible drive signal phases, in order for the transducer array to achieve an optimal performance. While a switching mechanism may be used to connect an appropriate drive signal to the respective transducer elements, as the number of transducer elements grows, a conventional switching mechanism would become cumbersome and cost-prohibitive to employ and control.

### SUMMARY OF THE INVENTION

[0007] In accordance with one aspect of the invention, systems and methods are provided for selectively connecting respective drive signals to respective transducer elements of an ultra-high density array of transducer elements in a focused ultrasound system. In one implementation, an ultrasonic transducer used for transmitting acoustic energy for thermal tissue treatment includes a relatively large number of transducer elements. By way of non-limiting example, the transducer may take the form of a flexible or semi-flexible strip that may be attached directly or indirectly to an exterior body surface for delivering targeted acoustic energy to tissue in an internal region of the body. The individual transducer

elements may be individually formed or provided on relatively small substrates (e.g., with each substrate comprising an array of transducer elements) that are attached to the transducer body. In order to drive the selected transducer elements at the appropriate phases, a drive signal generator may be employed to generate a number of possible drive signals having the same frequency, each drive signal being out of phase with the others by a selected phase offset amount. A two-tier hierarchical switching fabric is then employed to connect selected drive signals to selected transducer elements that are to be activated for a given tissue sonication.

[0008] In one embodiment, a first tier of the switching fabric selects a drive signal to be supplied to an identified subset of one or more transducer elements, and a second tier of the switching fabric connects the selected drive signal to the identified transducer element(s). In one embodiment, the first tier is implemented as a plurality of first tier switching modules, and the second tier is implemented as a plurality of second tier switching modules. Each first tier module has a number of inputs, each input coupled to a respective drive signal, where the number of inputs is equal to the number of drive signals. The inputs are selectively connectable to a common first tier module output via a respective first tier switch, e.g., a transistor or MEMs device. A respective drive signal selection control signal is received by the first tier modules for causing a selected one of the first tier switches to be activated to thereby couple a selected one of the drive signals to the respective first tier module output.

[0009] Each second tier switching module has a common input that is connected to an output of a respective first tier module. The second tier module inputs are selectively connectable to one or more second tier module outputs via a plurality of respective second tier switches, e.g., transistors and/or MEMs devices. Respective element selection control signals are received by the second tier modules for causing selected ones of the second tier switches to be activated, thereby coupling the respective drive signals to the selected second tier outputs. Individual groups of  $k$  transducer elements are connected (e.g., hard-wired or by using individual summing networks) to respective outputs of the second tier modules, where the  $n$  total transducer elements are connected in groups of  $k$  elements each to  $n/k$  total second tier modules.

[0010] The respective first and second tier switching modules may be provided in a substantially 1:1 ratio, where the output of a given first tier switching module is directly connected to the input of a second tier switching module. It will be appreciated that the physical implantation of the two-tier switching fabric need not necessarily take the form of distinct first and second "modules," and that embodiments of the invention make take a variety of physical forms.

[0011] Other and further aspects and features of embodiments of the invention will become apparent in view of the following detailed description and illustrated embodiments.

#### BRIEF DESCRIPTION OF THE DRAWINGS

[0012] The invention is illustrated by way of example and not limitation in the figures of the accompanying drawings, in which like references indicate similar elements, and in which:

[0013] FIGS. 1-2 are simplified schematic representations of an exemplary image-guided focused ultrasound system;

[0014] FIG. 3 is a simplified schematic illustration of an ultra-high density transducer element array;

[0015] FIGS. 4a-c are simplified schematic illustrations of a control system including a multi-tier switching fabric for selectively connecting drive signals to individual transducer elements of an ultra-high density transducer array of a focused ultrasound system, in accordance with one embodiment of the invention; and

[0016] FIG. 5 is a flow chart illustrating a method for providing a selected drive signal to a plurality of selected transducer elements, in accordance with one embodiment of the invention.

#### DETAILED DESCRIPTION

[0017] In the following description, references to "one embodiment" or "an embodiment" mean that the feature being referred to is included in at least one embodiment of the invention. Further, separate references to "one embodiment" in this description do not necessarily refer to the same embodiment; however, neither are such embodiments mutually exclusive, unless so stated and except as will be readily apparent to those skilled in the art. In particular, the invention can include any variety of combinations and/or integrations of the embodiments described herein.

[0018] The invention relates to systems and methods for selectively coupling one of a number of discrete drive signals to selected transducer elements of a high density array. The transducer elements of the array may be divided into individual groupings, with each grouping of transducer elements selectively coupled to a respective drive signal. In this manner, each transducer element in a given grouping may operate with the same phase. It may be desirable to connect only a single transducer element of a particular grouping to a respective drive signal, or it may be preferable to connect more than one transducer element of a grouping to a drive signal. In alternate embodiments (not depicted or further described herein), each grouping may be selectively coupled to multiple drive signals using a summing network, which is a network of passive components wired between adjacent transducer elements. This alternate approach enables manipulation and variation of the otherwise limited number of drive signals that are available to supply to the respective transducer element groupings. Briefly, the summing networks compose corrected drive signals from the planned drive signals and the relationship(s) between the adjacent elements. These networks are static and may represent a way to correct for geometric adjustments and any trimming of the drive signal, which may be pre-calculated and pre-adjusted by a static shift or summing the drive signals of adjacent transducer elements. In such alternate embodiments, each transducer element in a given grouping may operate with a phase that is a product of the particular summing network. Again, it may be desirable to connect only a single transducer element of a grouping to the respective phase signal, or it may be preferable to connect more than one transducer element to the signal.

[0019] More particularly, a switching network according to embodiments of the invention is designed to route appropriate drive signals to each transducer element of the trans-

ducer array using minimum number of source signals in order to drive a very large community of transducer elements in the array. The switching network employs switching modules which enable dynamic routing of drive signals to any specific element by employing a hierarchical approach.

[0020] In one implementation, a multi-tier switching fabric is provided to connect one or more of each grouping of transducer elements with a selected drive signal. A first tier of the switching fabric receives a plurality of drive signals and selectively outputs a single drive signal with a particular phase offset. A second tier of the switching fabric receives and couples the selected drive signals to selected ones or groupings of the transducer elements. For example, the first tier of the switching element may select a first drive signal with a first phase offset for a first grouping of transducer elements, and a second drive signal with a second phase offset for a second grouping of transducer elements. The second tier switching fabric may include a number of second tier switching modules, such as, for example, one second tier switching module for each grouping of transducer elements. Each second tier switching module receives a respective drive signal output from the first tier switching fabric, and selectively couples the received drive signal to one or more transducer elements connected to that module that are to be activated for a given sonication.

[0021] As shown in FIG. 3 a transducer 300 constructed according to one embodiment includes a high density array of individual transducer elements 304 for generating acoustic wave energy in a focused ultrasound system. In various embodiments, the transducer 300 may be implemented, for example, as a flexible substrate or band that may be placed around and/or coupled to an exterior surface (skin) of a patient, e.g., in a belt-like fashion. In another embodiment, the transducer 300 may be alternatively be implemented as a rigid structure, which is directly or indirectly coupled to a patient. Other implementations of the transducer 300, including various geometries for implementing a flexible or rigid transducer will be apparent to those skilled in the art, and the invention is not to be limited by the particular transducer implementation. In the embodiment shown in FIG. 3, the transducer 300 comprises an array of transducer tiles, 302a-302m, with each tile 302 comprising an array of individual transducer elements 304a-304i. Thus, in embodiments in which each of the transducer tiles 302a-302m has a same (or substantially same) number of transducer elements 304i, the total number of transducer elements n is equal (or approximately equal) to  $m \cdot i$ . The individual transducer elements 304a-304i of each tile are hard-wired to a switching front end (FIG. 4) in order to selectively couple activation drive signals to the elements for generating acoustic wave energy. For example, respective groupings of k transducer elements 304 may be hard-wired to corresponding outputs of respective switching modules (described below in conjunction with FIG. 4) associated with the switching front end.

[0022] The particular transducer elements that are connected to a given second tier module will be a design consideration and the connection patterns may vary among embodiments of the invention. For example, it may be desirable to select the locations of the k elements connected to a given second tier module based on achieving physical proximity or diversity of the respective individual elements

in each grouping. Alternatively, it may be desirable to randomly connect the groupings of transducer elements to the respective switching modules, without any regard for the particular location on the transducer of the k elements. In one embodiment, the group size k corresponds to the number of transducer elements 304 located on a single tile 302, and the groupings are connected on a tile-by-tile basis. In another embodiment, the groupings comprise individual elements 304 located on different tiles 302. For example, each grouping may include one transducer element 304 from each tile 302a-302m, where the group size is m. In other embodiments, each grouping may include a differing number of transducer elements 304, which may be randomly or pseudo-randomly distributed across the respective tiles 302a-302n. Other implementations of the transducer element groups will be apparent to those skilled in the art. Moreover, the individual transducer elements 304 may be provided in different forms than on the tile arrays 302, which is just one example and embodiments of the invention may be useful and suitable for any transducer embodiment having a substantially high number of individually activatable elements, and are particularly suitable for ultra-high density arrays containing a relatively high number of individually activatable elements.

[0023] Although the individual transducer elements are preferably relatively small (and, thus, each transmits a relatively low power wave), what they lack in individual power output is made up for in the quantity of possible elements that may be simultaneously fired for a given sonication. Notably, a relatively small percentage of the total number of transducer elements (e.g., on the order of 5% or 10%) are typically activated for a given sonication. The individual transducer elements to be activated, along with the respective drive signal attributes (e.g., phase and amplitude) for each element, may be selected or determined by a planning system incorporated within the focused ultrasound system. The transducer elements may be "localized" relative to the local zone, e.g., by using a positioning systems to identify the respective locations of the transducer elements in a reference frame including the target tissue region and acoustic window (transmission path). This information, along with three-dimensional images of the internal body region including the target tissue region, can be used to identify a preferred and/or optimal combination of individual transducer elements to be activated. The element selection criteria may include many factors, such as, e.g., avoiding acoustic energy transmission through sensitive body tissue (e.g., ribs or lungs).

[0024] FIG. 4a is a block diagram illustrating a first switching front end embodiment 400, which generally includes a drive signal generator 402, a controller 404, and a plurality of switching elements 406a-j. The drive signal (or "phasor") generator 402 generates a plurality of drive signals 403 at a selected frequency, that may be used to drive transducer elements 304a-304n, the use of transducer elements 304a-304n in all the switching elements 406a to 406j is for purposes of simplicity and is not intended to mean that the same elements are connected to all switching elements.

[0025] In particular, the respective drive signals 403 generated by the drive signal generator 402 are phase shifted from each other, such that each drive signal has a distinct phase offset from a base signal. By way of non-limiting example, in one embodiment, the drive signal generator 409

may supply twelve distinct drive signals **403** at a selected frequency, the drive signals being successively offset in phase by 30° each, i.e., where the respective drive signals are phase offset from a base signal (0°) by: 30°, 60°, 90°, 120°, 150°, 180°, 210°, 240°, 270°, 300°, and 330°.

[0026] Many other embodiments are also possible, e.g., the drive signal generator **402** may supply eighteen distinct drive signals **403** at a selected frequency and successively offset in phase by 20° each, i.e., 0°, 20°, 40°, 60°, 80°, 100°, 120°, 140°, 160°, 180°, 200°, 220°, 240°, 260°, 280°, 300°, 320°, and 340°. Other phases may also be combined to drive elements in embodiments that are driven from a summation network instead of from a single drive signal. It will be appreciated by those skilled in the art that it may be desirable to adjust the output power (amplitude) of the respective drive signals upward or downward, depending on the actual number of transducer elements the respective signals will drive during a given sonication, in order to reduce variations in the acoustic impedance of the individual acoustic waves as they converge in the focal region.

[0027] The controller **404** outputs control signals that are used to control switching elements **406a-j**. Each of the switching elements **406a-j** operates to select one drive signal **403'** from the plurality of drive signals **403** generated by the drive signal generator **402**, and to provide the selected drive signal **403'** to selected ones of the transducer elements **304a-304n**, as specified by the controller **404**.

[0028] In one implementation, each of the switching elements **406a-j** is a hierarchical switching element that includes, for example, a first tier switching module **408a-j**, and a second tier switching module **410a-j**. The first tier switching module **408a-j** may be used to select one drive signal **403'** from the plurality of drive signals **403** output by the drive signal generator **402**, and the second tier switching module **410a-j** may be used to provide the selected drive signal **403'** to selected ones of the switching elements **304a-304n**.

[0029] As shown in FIGS. **4a** and **4b**, the first tier switching module **408a** receives a plurality of drive signals **403** from the drive signal generator **402**, and receives a drive signal selector **405** from the controller **404**. The first tier switching module **408a** operates to select one drive signal **403'** from the plurality of drive signals **403** based on the drive signal selector **405**, and outputs the selected drive signal **403'** to the second tier switching module **410**.

[0030] The drive signal selector **405** contains sufficient information to allow the first tier switching module **408a** to select one drive signal **403'** from the plurality of drive signals **403**. The drive signal selector **405** may contain a plurality of signals, as shown in FIG. **4b**, or may contain a single signal, as shown in FIG. **4a**. In one implementation, the first tier switching module **408a** may contain a de-multiplexer that allows a single drive signal selector **405** to be used.

[0031] As shown in FIGS. **4a** and **4b**, the second tier switching module **410** receives a selected drive signal **403'** from the first tier switching module **408a**, and receives one or more transducer element selectors **411** from the controller **404**. The information received in the one or more transducer element selectors **411** may be sufficient to describe which of the transducer elements **304a-n** in the grouping are to be

turned on at a particular time. Although the one or more transducer element select signals **411** are depicted in FIG. **2** as a plurality of signals received in parallel, those skilled in the art will appreciate that the one or more transducer element select signals **411** could be received in series or in parallel. Furthermore, those skilled in the art will appreciate that the one transducer element select signal **411** could be provided to the second tier switching module **410a**, that a number of transducer element select signals **411** equal to the number of transducer elements **304a-n** in the grouping could be provided to the second tier switching module **410a**, or that another number of transducer element select signals **411** could be provided. In one implementation, the second tier switching module **410a** contains a de-multiplexer that allows a single input signal **411** to be used.

[0032] The information received in the one or more transducer element selectors may be sufficient to describe which of the transducer elements **304a-304n** in the grouping are to be turned on at a particular time. Based on the one or more transducer element selectors, the drive signal received from the first tier switching module **408a-b** is provided selectively to those transducer elements that are to be turned on.

[0033] While the switching mechanism has been described in terms of discrete switching elements **406a-j**, each switching element including a first tier switching module **408a-j** and a second tier switching module **410a-j**, other implementations of the switching mechanism will occur to those skilled in the art. In particular it is contemplated that a single first tier switching module **408** may be provided for a plurality of second tier switching modules **410a-j**. Other configurations will occur to those skilled in the art. Alternate configurations for the switching fabric are illustrated in FIG. **4c**.

[0034] FIG. **4c** is a block diagram illustrating a system for switching transducer elements ("switching front end"). The system **420** of FIG. **4c** is similar to the system **400** of FIG. **4a**. However, in the system **420** of FIG. **4c**, the mapping of first tier switching modules to second tier switching modules need not be one to one. In particular, the system **420** of FIG. **4c** may include a single first tier switching module **422a** that provides drive signals to a plurality of second tier switching modules **424a-k**.

[0035] As shown in FIG. **4c**, the system **420** may include a drive signal generator **402** and a controller **404**, similar to those discussed above with reference to FIG. **4a**. Furthermore, the system **420** may include a first tier switching fabric **426** and a second tier switching fabric **428**. The first tier switching fabric **426** may be made up of one or more first tier switching modules **422a-j**, and the second tier switching fabric **428** may be made up of one or more second tier switching modules **424a-k**.

[0036] Each of the first tier switching modules **422a-j** may be coupled to one or more second tier switching modules **424a-k**. Each of the first tier switching modules **422a-j** may be configured to output one drive signal **403'** to each of the second tier switching modules **424a-k** coupled to it. The first tier switching modules **422a-j** need not output the same drive signal to each of the second tier switching modules **424a-k**, but may provide a first drive signal **403'** to a second tier switching module **424a**, a second drive signal **403'** to another second tier switching module **424b**, and so on.

[0037] Each of the second tier switching modules **424a-k** may be associated with one grouping **430** of transducer

elements **304a-p**. Each of the second tier switching modules **424a-k** may be coupled to the transducer elements **304a-p** in the grouping **430**. Each of the second tier switching modules **424a-k** may receive one drive signal **403'** from a first tier switching module **422a-j**, and may output the received drive signal **403'** to selected ones of the transducer elements **304a-p** in the grouping **430**.

[0038] As discussed above with reference to FIG. 3, each grouping **430** of transducer elements **304a-p** may include, for example, a plurality of transducer elements that may be located on one tile, or may include a plurality of transducer elements located, for example, on a plurality of tiles. In alternate embodiments, the transducer elements may not be located on tiles but may nevertheless be formed into groupings.

[0039] In one implementation, each of the first tier switching elements **422a-j** receives a plurality of drive signals **403** from the drive signal generator **402**, and receives one or more drive signal selectors **405** from the controller **404**. The first tier switching elements **426a-j** operate to select a drive signal **403'** from the plurality of drive signals **403** for each of the second tier switching elements **424a-k** coupled to it, based on the drive signal selectors **405**. Each of the first tier switching elements **422a-j** outputs the appropriate selected drive signal(s) **403'** to each of the second tier switching modules **494a-k** coupled to it.

[0040] Each of the second tier switching modules **424a-k** receives a selected drive signal **403'** from a first tier switching module **422a-j**, and receives one or more transducer element selectors **411** from the controller **404**. The information received in the transducer element selectors **411** may be sufficient to describe which of the transducer elements **304a-p** in the grouping **430** are to be turned on at a particular time. Based on the transducer element selectors **411**, the drive signal **403'** received from the first tier switching module **422a-j** is provided selectively to those transducer elements **304a-p** that are to be turned on.

[0041] While the switching mechanism has been described in terms of discrete first tier switching modules **422a-j** coupled to second tier switching modules **424a-1k**, other implementations will occur to those skilled in the art. In particular, it is contemplated that a single first tier switching module **422a** may be provided for a plurality of second tier switching modules **424a-k**. The single first tier switching fabric **422a** may receive a plurality of drive signals **403** from the drive signal generator **402**, and may output one drive signal **403'** to each of the second tier switching modules **424a-k**.

[0042] In another implementation, a number of first tier switching modules **422a-j** may each be coupled to a number of second tier switching modules **424a-k**. In this implementation, the number of second tier switching modules **422a-k** coupled to each first tier switching module **424a-j** may be limited, for example, to ensure that the signal strength is sufficient to drive the transducer elements **304a-p**. Other implementations of the switching mechanism will occur to those skilled in the art.

[0043] In some implementations, each drive signal **403** may be applied to a varying number of transducer elements **304a-p**, as each drive signal **403** may be provided to a varying number of second tier switching modules **424a-j**,

and as each of the second tier switching modules **424a-j** may provide the drive signal **403** to varying numbers of transducer elements **305a-p**. However, when the number of second tier switching modules **424** and the number of transducer elements **304a-p** is large, statistical distribution may limit this variation. Thus, it may not be necessary to adjust the power of the drive signals **403** based on the load. However, in some implementations, the power of each drive signal **403** may be adjusted based on the number of transducer elements **304a-p** to be driven. For example, the controller **404** may adjust the power of the drive signals **403**.

[0044] FIG. 5 is a flow chart illustrating a method for providing a drive signal to a plurality of transducer elements. As shown in FIG. 5, the method may begin in step **500**, wherein transducer elements may be identified for a given sonication, and, phases may be identified for each transducer element. Step **500** may be performed, for example, by a controller that receives image data, such as MRI data, and determines which transducer elements are to be turned on, and at which phase to operate each transducer element.

[0045] The method may continue in step **502**, wherein a plurality of drive signals may be received. The plurality of drive signals may be received, for example, from a drive signal generator. The plurality of drive signals may be phase shifted such that each drive signal has a distinct phase.

[0046] The method may continue in step **504**, wherein one drive signal may be selected from the plurality of drive signals. The drive signal may be selected, for example, based on a drive signal selector received from a controller.

[0047] In step **506**, one or more transducer elements may be selected. The transducer elements may be selected, for example, from the grouping of transducer elements. The transducer elements may be selected based on one or more transducer element selectors that are received, for example, from a controller.

[0048] In step **508**, the selected drive signal may be applied to the selected transducer elements. The drive signal may be applied, for example, to activate the transducer elements to produce ultrasound energy.

[0049] In the foregoing specification, the invention has been described with reference to specific embodiments thereof. It will, however, be evident that various modifications and changes may be made thereto without departing from the broader spirit and scope of the invention. For example, the reader is to understand that the specific ordering and combination of process actions shown in the process flow diagrams described herein is merely illustrative, and the invention can be performed using different or additional process actions, or a different combination or ordering of process actions.

[0050] For example, while the invention has been described in terms of one drive signal generator that outputs drive signals for all the transducer elements, it is contemplated that more than one drive signal generator may be provided. Each drive signal generator may be dedicated to provide a plurality of drive signals to specific switching mechanisms or to specific transducer elements. Alternatively or in addition, each drive signal generator may be dedicated to provide one or more signals with one or more particular phases. Further, as briefly described above, each grouping may be selectively coupled to multiple drive signals using a

summing network to enable further manipulation of the available drive signals. In such alternate embodiments, each transducer element in a given grouping may operate with a phase that is a product of the particular summing network.

[0051] Accordingly, the specification and drawings are to be regarded in an illustrative, rather than restrictive sense.

What is claimed is:

1. A focused ultrasound system, comprising:
  - a transducer having a multiplicity of transducer elements;
  - a drive signal generator that generates and outputs a plurality of drive signals offset in phase relative to one another;
  - a controller;
  - a plurality of first tier switching modules, each first tier module receiving as inputs the plurality drive signals, and configured to selectively output one of the drive signals based on a respective drive signal selection signal received from the controller, and
  - a plurality of second tier switching modules, each second tier module receiving as an input a selected drive signal output from a respective first tier module, and configured to selectively couple the drive signal to one or more transducer elements of a respective grouping of transducer elements based on a respective transducer element selection signal received from the controller.
2. The focused ultrasound system of claim 1, wherein the respective grouping of transducer elements are fixedly connected to the respective second tier switching module.
3. The focused ultrasound system of claim 1, wherein each of the multiplicity of transducer elements is part of a respective one of a plurality of groupings of transducer element, and wherein the transducer elements of each grouping are fixedly connected to a respective one of the second tier switching modules.
4. The focused ultrasound system of claim 3, wherein the multiplicity of transducer elements are implemented as a plurality of transducer element arrays, each array being formed on a separate substrate.
5. The focused ultrasound system of claim 4, wherein substantially all of the transducer elements of at least one grouping are located on a single one of the arrays.
6. The focused ultrasound system of claim 4, wherein substantially all of the transducer elements of at least one grouping are located on different arrays.
7. The focused ultrasound system of claim 1, further comprising a plurality of switching elements, each switching element comprising a respective first tier module and a respective second tier module, wherein the second tier module receives as an input the selected drive signal output from the first tier module of the same switching element.
8. The focused ultrasound system of claim 1, further comprising a first tier switching fabric and a second tier switching fabric, the first tier fabric comprising the plurality of first tier modules and the second tier fabric comprising the plurality of second tier modules.
9. The focused ultrasound system of claim 1, wherein the controller is configured to supply the respective drive signal and transducer element selection signals to the first and second tier switching modules in order to activate a selected subset of the transducer elements to thereby transmit a targeted acoustic energy burst.

10. The focused ultrasound system of claim 9, wherein each of the multiplicity of transducer elements is part of a respective one of a plurality of groupings of transducer element, the transducer elements of each grouping being fixedly connected to a respective one of the second tier switching modules, and wherein the subset of transducer elements comprises less than all of the transducer elements of at least one grouping.

11. The focused ultrasound system of claim 9, wherein the multiplicity of transducer elements are implemented as a plurality of transducer element arrays, each array being formed on a separate substrate, and wherein the subset of transducer elements comprises less than all of the transducer elements of at least one array.

12. A method of delivering target acoustic energy to body tissue using a transducer having a multiplicity of transducer elements, the method comprising:

identifying one or more of the transducer elements to be activated in order to transmit a targeted acoustic energy burst from the transducer;

providing as inputs to each of a plurality of first tier switching modules a plurality of drive signals having phase differences;

selectively outputting a respective one of the drive signals from each of the plurality of first tier switching modules,

providing as inputs to each of a plurality of second tier switching modules a respective one of the drive signals output from the first tier modules;

for each of the plurality of second tier switching modules, selectively coupling the respective input drive signal to one or more transducer elements of a respective grouping of transducer elements connected to the respective second tier switching module.

13. The method of claim 12, wherein the transducer elements are implemented as a plurality of transducer element arrays, each array being formed on a separate substrate.

14. The method of claim 13, wherein substantially all of the transducer elements of at least one grouping are located on a single one of the arrays.

15. The method of claim 13, wherein substantially all of the transducer elements of at least one grouping are located on different arrays.

16. The method of claim 12, further comprising providing a drive signal selection signal to each of the first tier modules, and wherein the respective drive signals are selectively output from the first tier modules based the received drive signal selection signal.

17. The method of claim 12, wherein each of the multiplicity of transducer elements is part of a respective one of a plurality of groupings of transducer element, the transducer elements of each grouping being fixedly connected to a respective one of the second tier switching modules, and wherein the subset of transducer elements comprises less than all of the transducer elements of at least one grouping.

18. The method of claim 12, wherein at least some of the drive signals are supplied to first tier switching modules using respective summing networks.

19. A system for delivery targeted acoustic energy to tissue, comprising:

a transducer having a multiplicity of transducer elements;  
a controller;

a plurality of first tier switching modules, each first tier module receiving as inputs a plurality drive signals having respective phase differences; and configured to selectively output one of the drive signals based on a respective drive signal selection signal received from the controller, and

a plurality of second tier switching modules, each second tier module receiving as an input a selected drive signal output from a respective first tier module, and configured to selectively couple the drive signal to one or more transducer elements of a respective grouping of transducer elements connected to the respective second tier switching module based on a respective transducer element selection signal received from the controller.

wherein the controller is configured to supply the respective drive signal and transducer element selection signals to the first and second tier switching modules in order to activate a selected subset of the transducer elements to thereby transmit a targeted acoustic energy burst.

**20.** The system of claim 19, wherein each of the multiplicity of transducer elements is part of a respective one of a plurality of groupings of transducer element, and wherein the transducer elements of each grouping are fixedly connected to a respective one of the second tier switching modules.

**21.** The system of claim 20, wherein the multiplicity of transducer elements are implemented as a plurality of trans-

ducer element arrays, each array being formed on a separate substrate.

**22.** The system of claim 21, wherein substantially all of the transducer elements of at least one grouping are located on a single one of the arrays.

**23.** The system of claim 21, wherein substantially all of the transducer elements of at least one grouping are located on different arrays.

**24.** The system of claim 19, further comprising a plurality of switching elements, each switching element comprising a respective first tier module and a respective second tier module, wherein the second tier module receives as an input the selected drive signal output from the first tier module of the same switching element.

**25.** The system of claim 19, further comprising a first tier switching fabric and a second tier switching fabric, the first tier fabric comprising the plurality of first tier modules and the second tier fabric comprising the plurality of second tier modules.

**26.** The system of claim 19, wherein each of the multiplicity of transducer elements is part of a respective one of a plurality of groupings of transducer element, the transducer elements of each grouping being fixedly connected to a respective one of the second tier switching modules, and wherein the subset of transducer elements comprises less than all of the transducer elements of at least one grouping.

**27.** The system of claim 19, wherein at least some of the drive signals are supplied to first tier switching modules using respective summing networks.

\* \* \* \* \*

专利名称(译)	超高密度超声阵列中的分层切换		
公开(公告)号	<a href="#">US20070167781A1</a>	公开(公告)日	2007-07-19
申请号	US11/562749	申请日	2006-11-22
[标]申请(专利权)人(译)	因赛泰克有限公司		
申请(专利权)人(译)	InSightec的有限公司.		
当前申请(专利权)人(译)	InSightec的有限公司.		
[标]发明人	VORTMAN KOBI MEDAN YOAV EZION AVNER		
发明人	VORTMAN, KOBI MEDAN, YOAV EZION, AVNER		
IPC分类号	A61B8/00		
CPC分类号	G01S15/8925 G01S7/52019 G10K11/346 G01S15/8927 A61B8/4494		
优先权	60/739862 2005-11-23 US		
其他公开文献	US8608672		
外部链接	<a href="#">Espacenet</a> <a href="#">USPTO</a>		

摘要(译)

聚焦超声系统包括具有多个换能器元件的换能器，产生和输出多个驱动信号的驱动电路，每个驱动信号通过相应的相位差偏移，以及用于选择性地将驱动信号耦合到相应的换能器元件的控制器，控制器包括多个第一层交换模块和第二层交换模块。每个第一层模块接收多个驱动信号作为输入，并响应于驱动信号选择信号输出一个驱动信号。每个第二层模块耦合到相应的换能器元件组，并且响应于换能器元件选择信号，选择性地将第一层切换模块输出的相应选择的驱动信号耦合到一个或多个换能器元件。

