



US 20190076121A1

(19) **United States**

(12) **Patent Application Publication**
Southard et al.

(10) **Pub. No.: US 2019/0076121 A1**
(43) **Pub. Date: Mar. 14, 2019**

(54) **ULTRASOUND FINGER PROBE**

Publication Classification

(71) Applicant: **Bard Access Systems, Inc.**, Salt Lake City, UT (US)

(51) **Int. Cl.**
A61B 8/00 (2006.01)
A61B 8/12 (2006.01)

(72) Inventors: **Jeanette E. Southard**, Park City, UT (US); **Matthew J. Prince**, West Jordan, UT (US); **Tab Robbins**, Layton, UT (US); **Timothy L. Creamer**, Ocean Springs, MS (US); **Kent F. Beck**, Layton, UT (US); **Paul T. Westwood**, Kaysville, UT (US); **Andrew J. Lengyel**, Sandy, UT (US)

(52) **U.S. Cl.**
CPC *A61B 8/4455* (2013.01); *A61B 8/12* (2013.01); *A61B 8/54* (2013.01); *A61B 8/4254* (2013.01)

(21) Appl. No.: **16/130,756**

(57) **ABSTRACT**

(22) Filed: **Sep. 13, 2018**

An ultrasound probe (“probe”) for use with an ultrasound imaging system is disclosed. In particular, the probe is sized and configured so as to be supported and readily used with as little as one finger on a single hand of a user of the imaging system. This configuration enables remaining fingers on the hand of the user to be employed for other purposes, such as skin traction and patient contact. In one embodiment, therefore, an ultrasound probe is disclosed, comprising a body, a lens included on head portion of the body, a stabilizing portion extending from the body and configured to stabilize the body on a skin surface of a patient without user assistance, and a finger grip portion configured to enable a user of the probe to grasp and maneuver the probe during use thereof with no more than two fingers on a single hand of the user.

Related U.S. Application Data

(60) Provisional application No. 62/558,234, filed on Sep. 13, 2017.

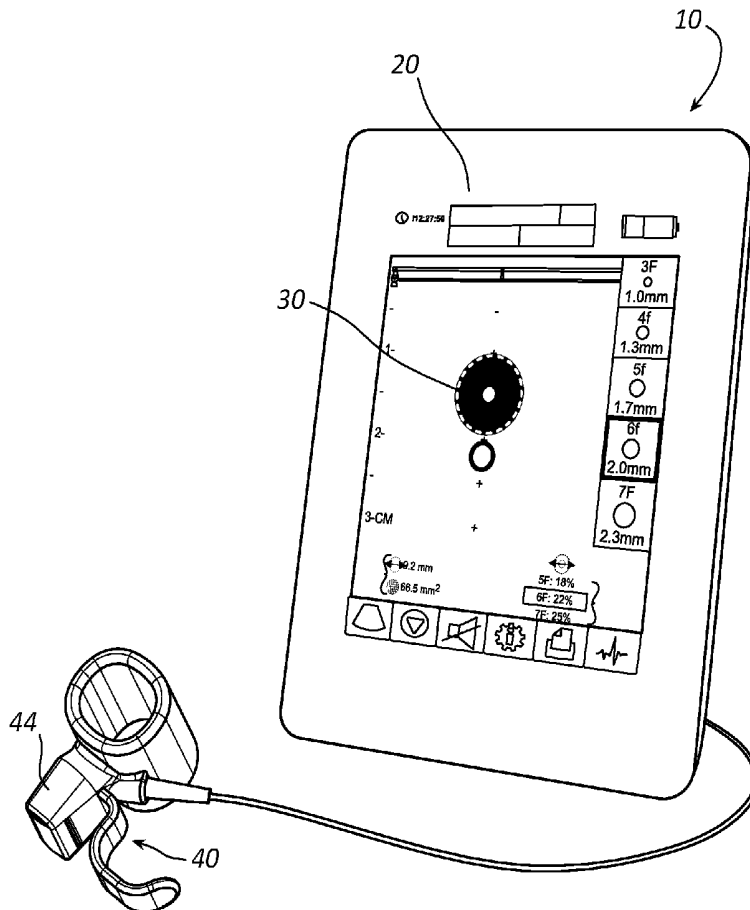

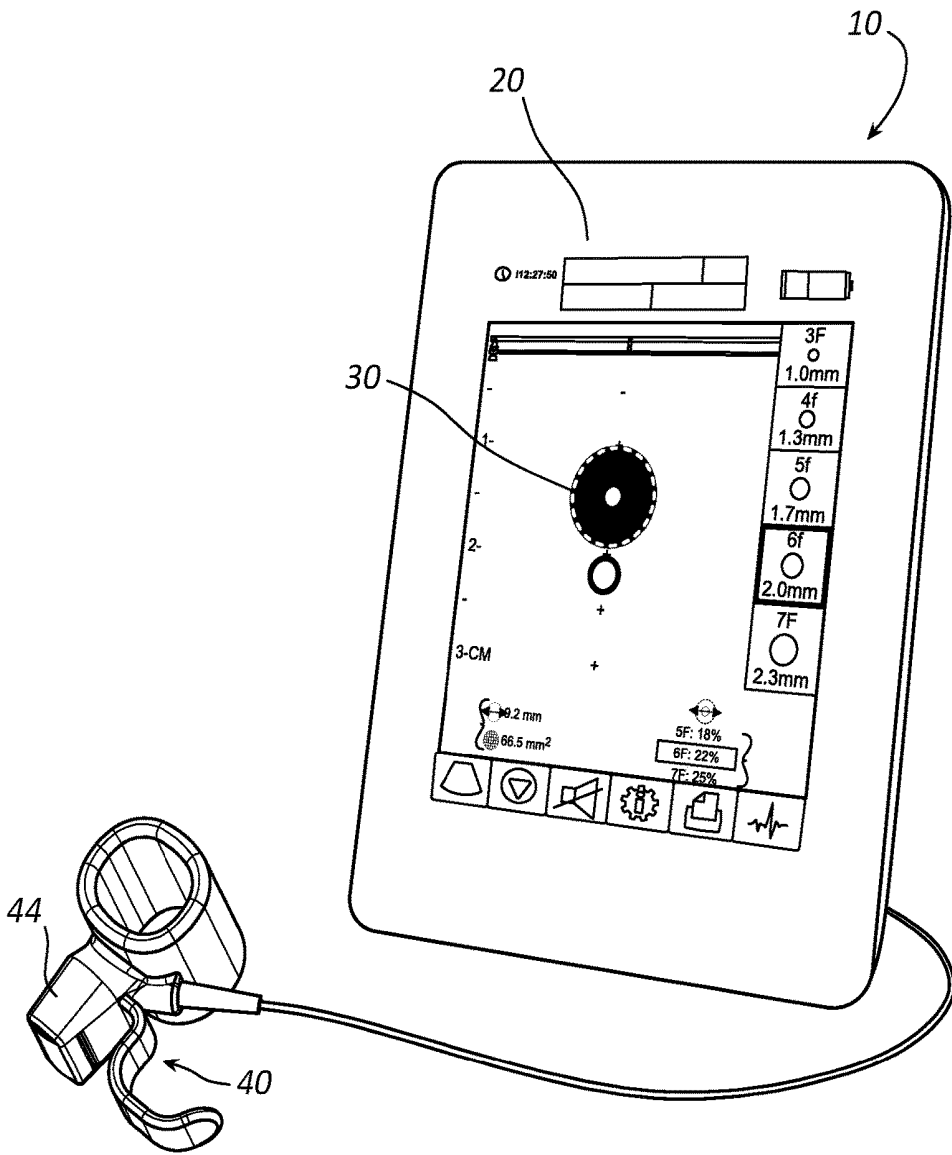

FIG. 1

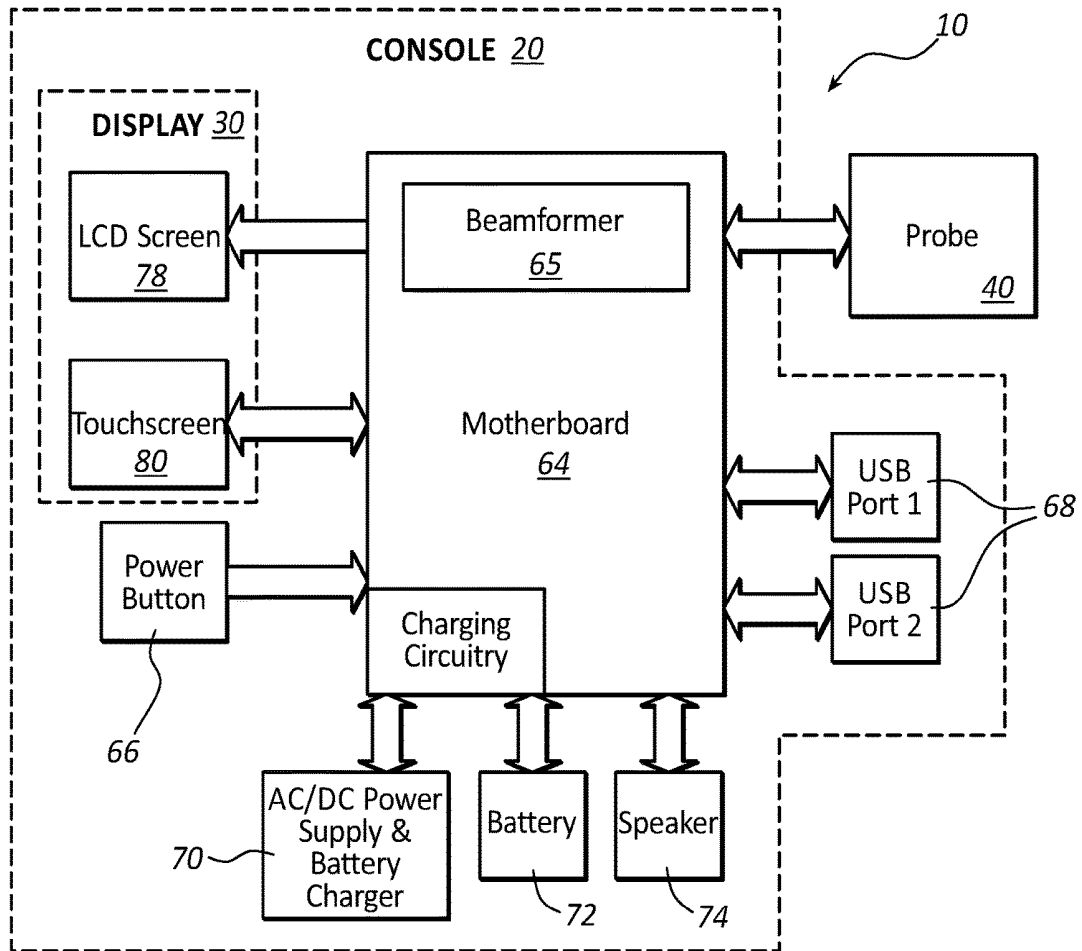

FIG. 2

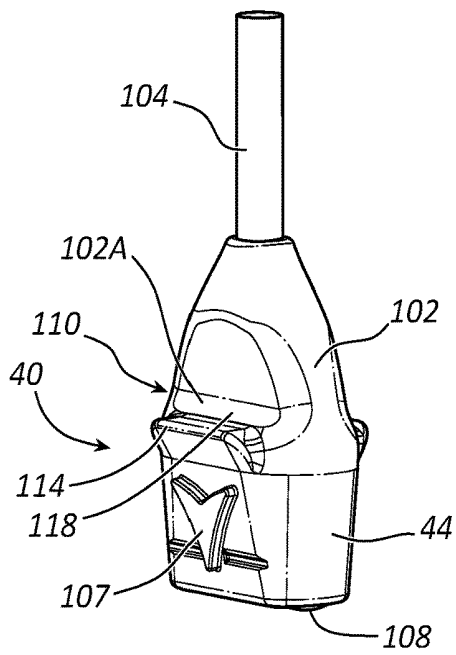

FIG. 3A

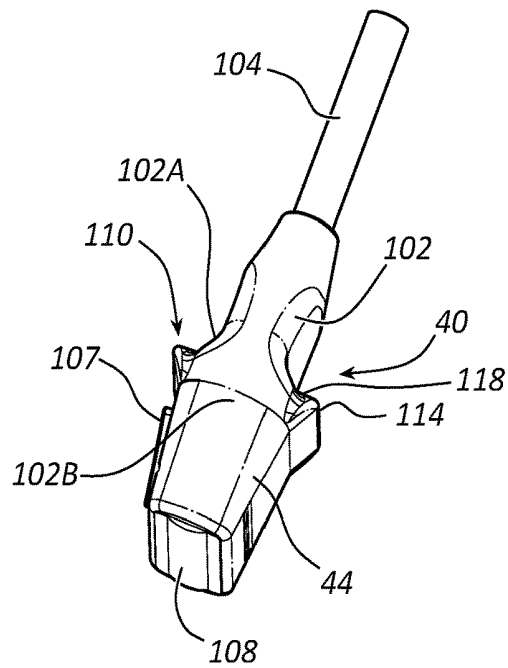

FIG. 3B

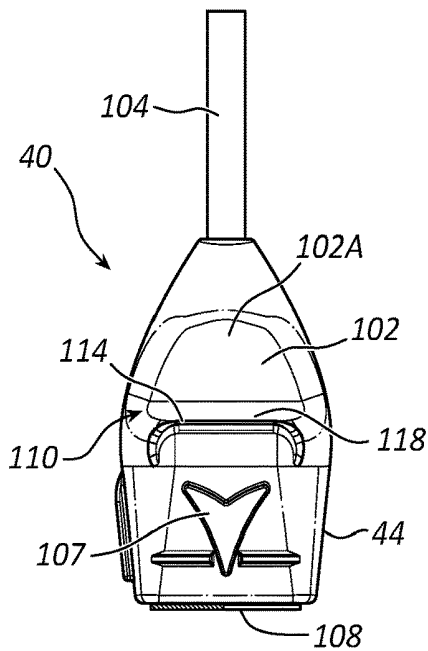

FIG. 3C

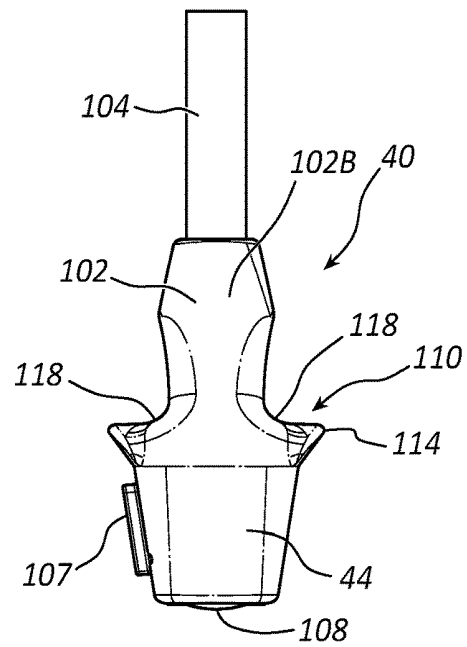

FIG. 3D

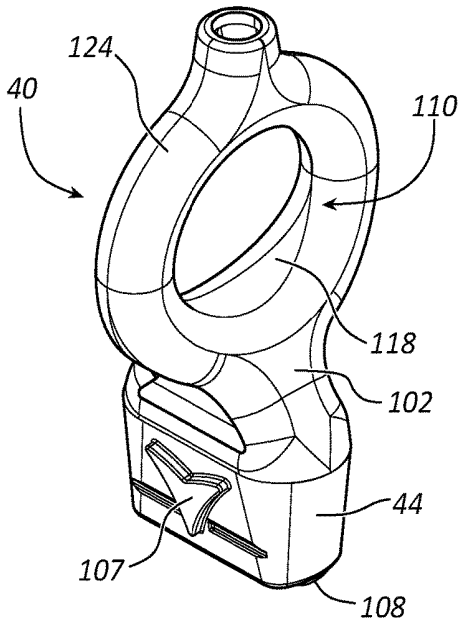

FIG. 4A

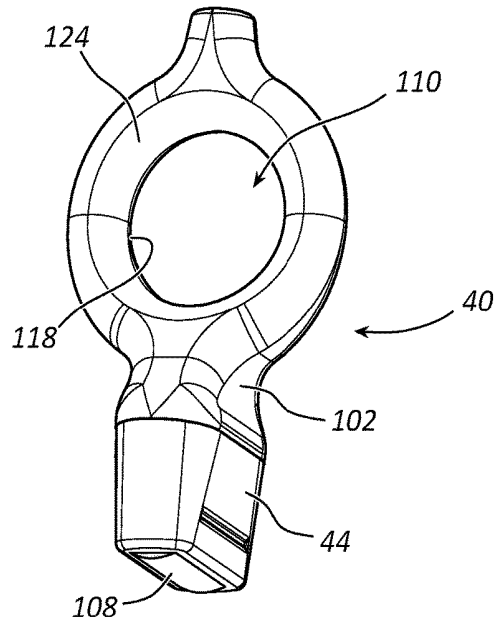

FIG. 4B

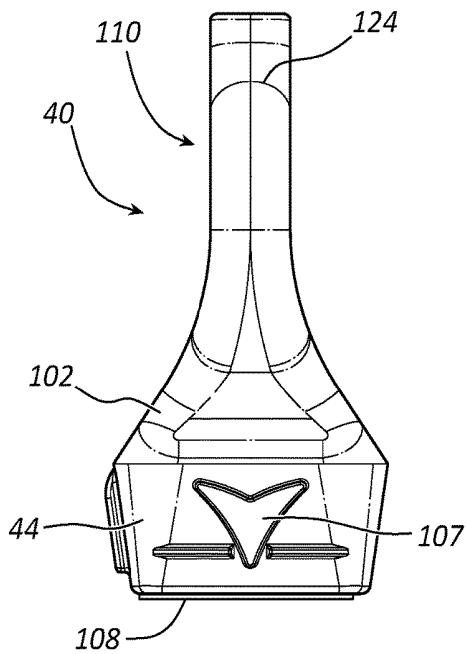

FIG. 4C

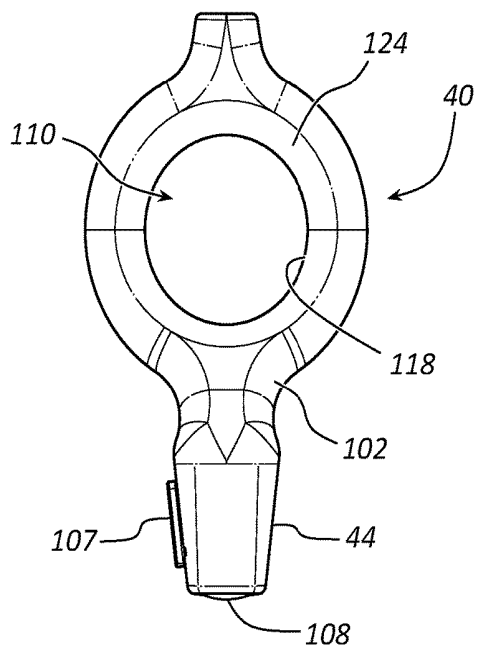

FIG. 4D

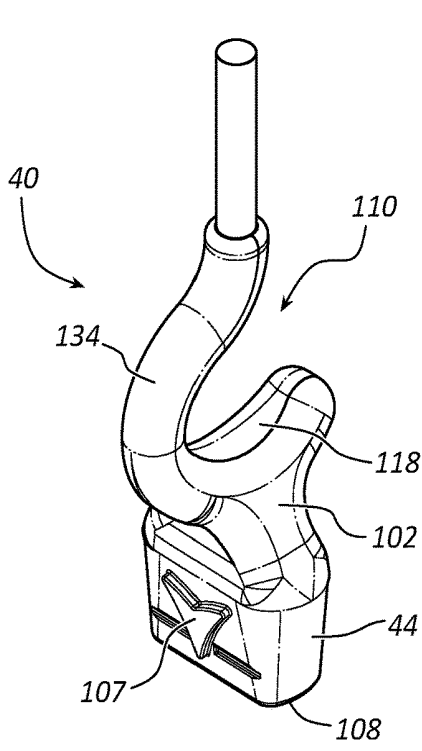

FIG. 5A

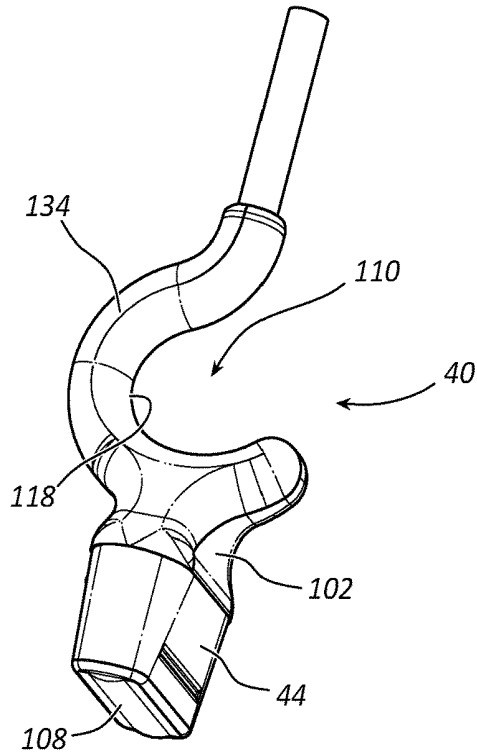

FIG. 5B

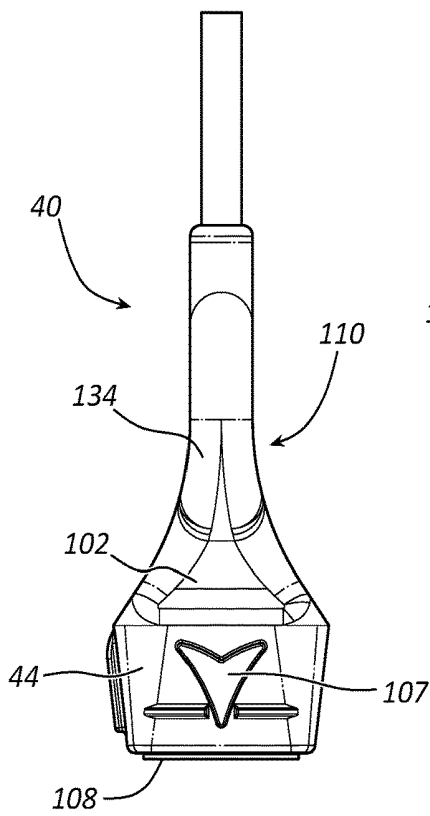

FIG. 5C

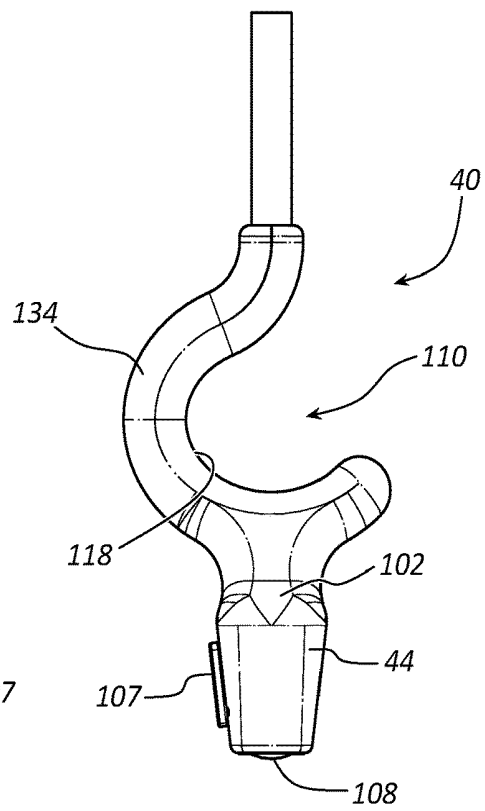

FIG. 5D

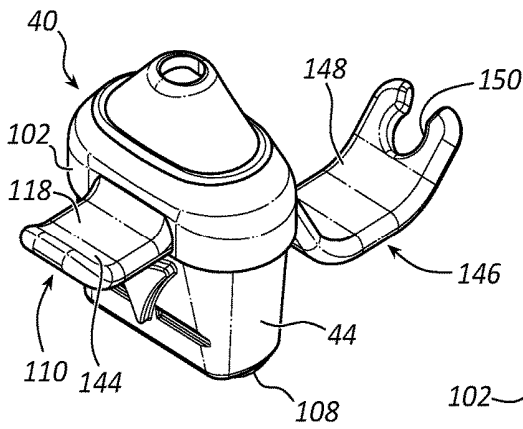

FIG. 6A

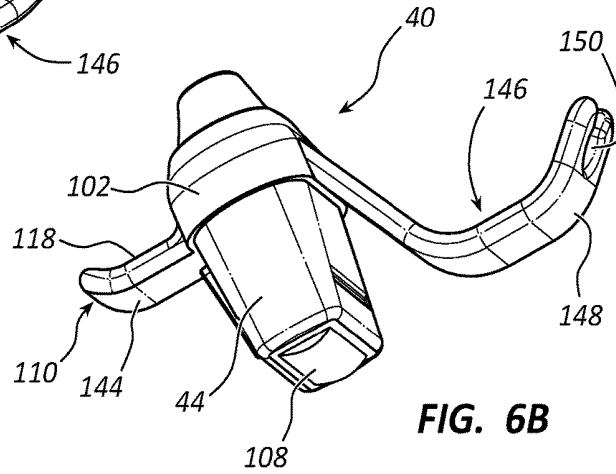

FIG. 6B

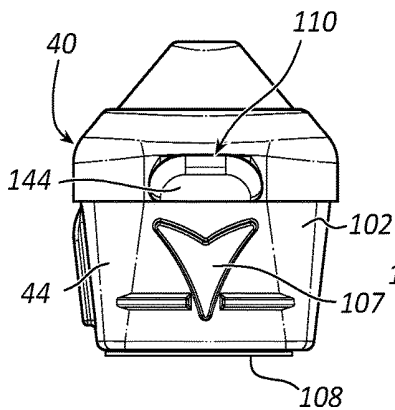

FIG. 6C

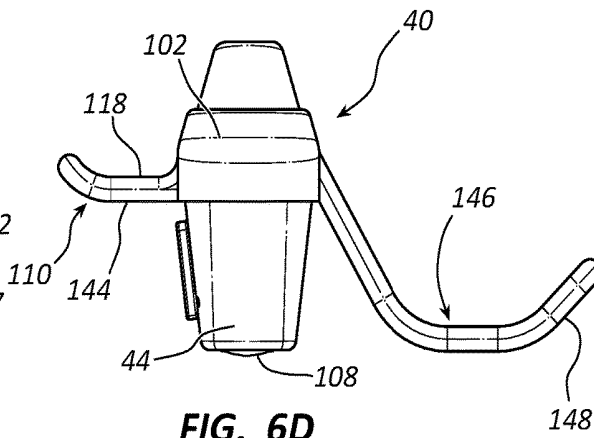

FIG. 6D

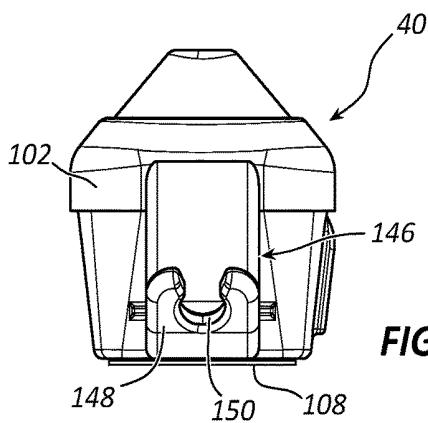

FIG. 6E

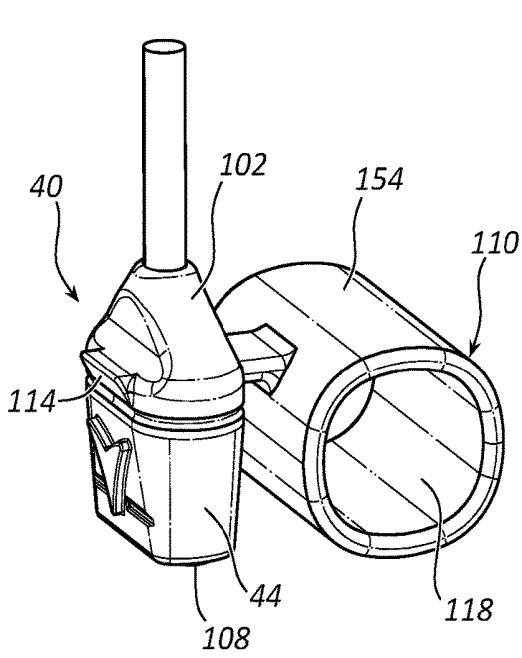

FIG. 7A

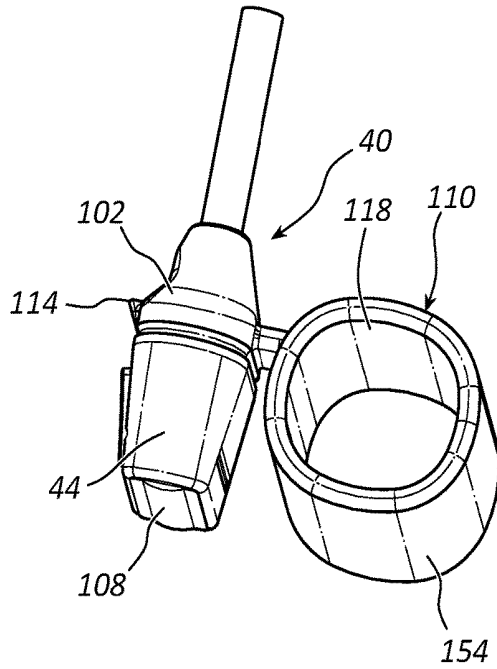

FIG. 7B

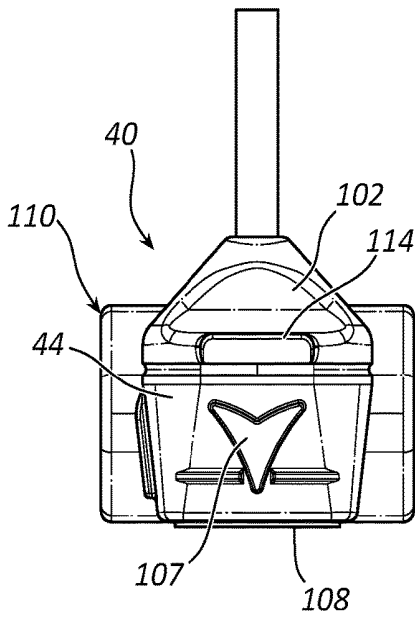

FIG. 7C

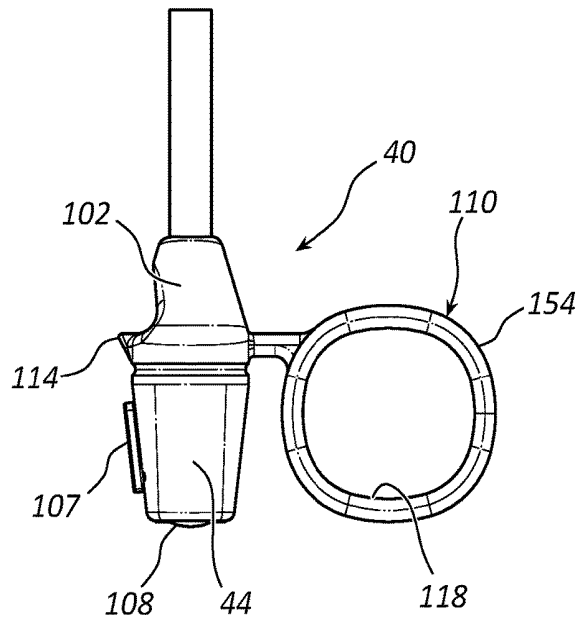

FIG. 7D

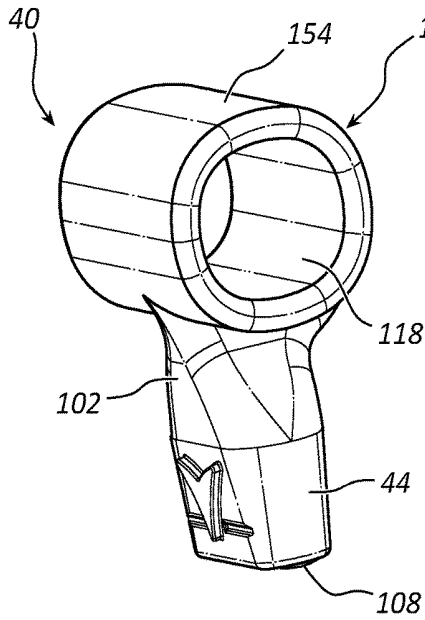

FIG. 8A

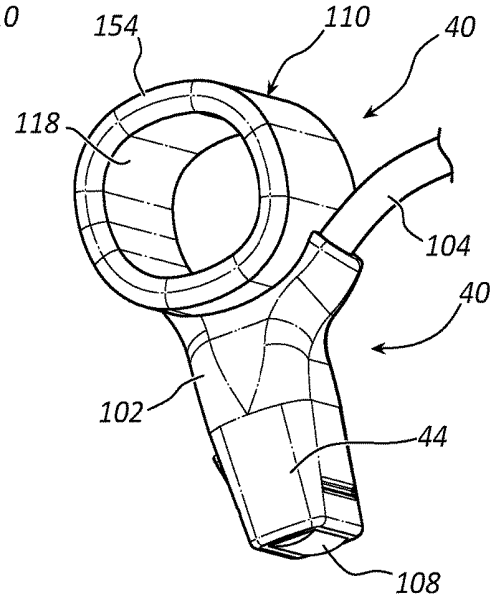

FIG. 8B

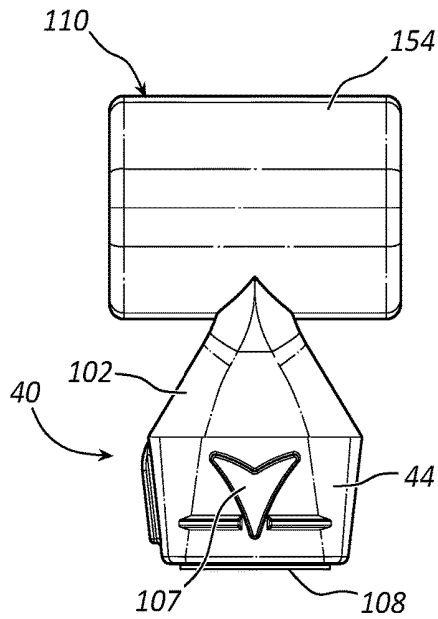

FIG. 8C

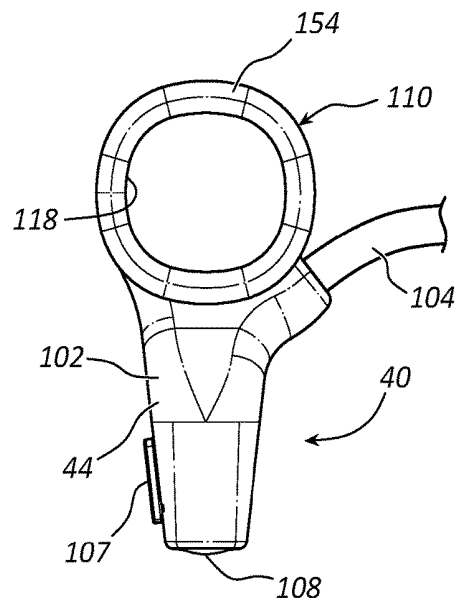

FIG. 8D

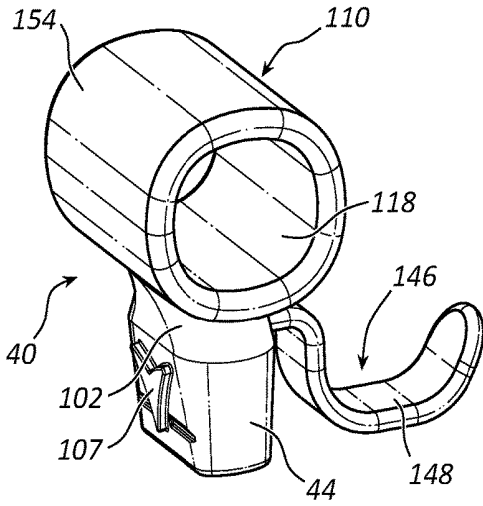

FIG. 9A

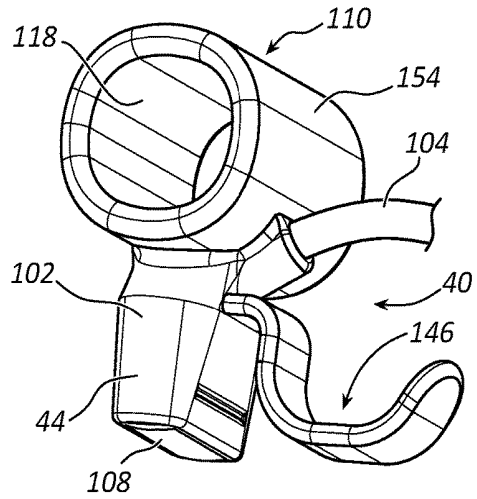

FIG. 9B

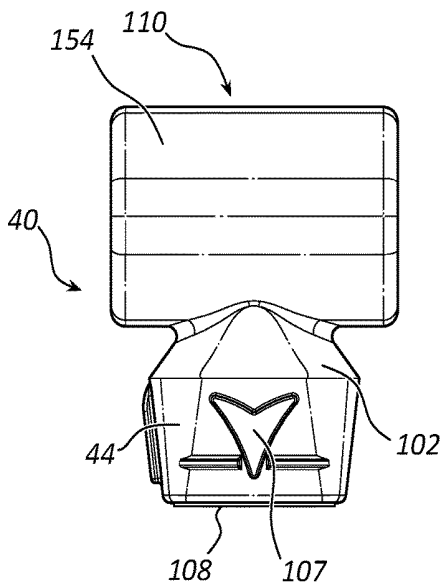

FIG. 9C

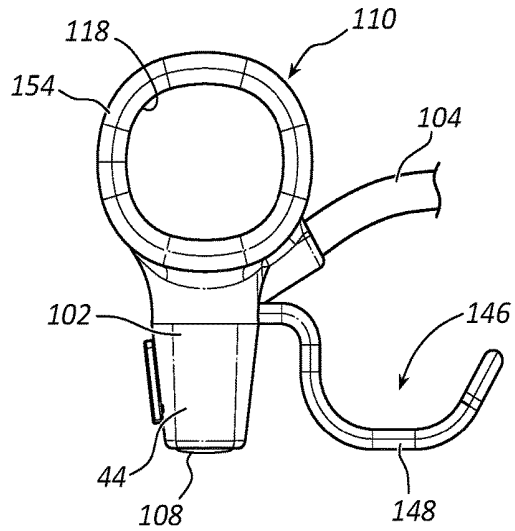

FIG. 9D

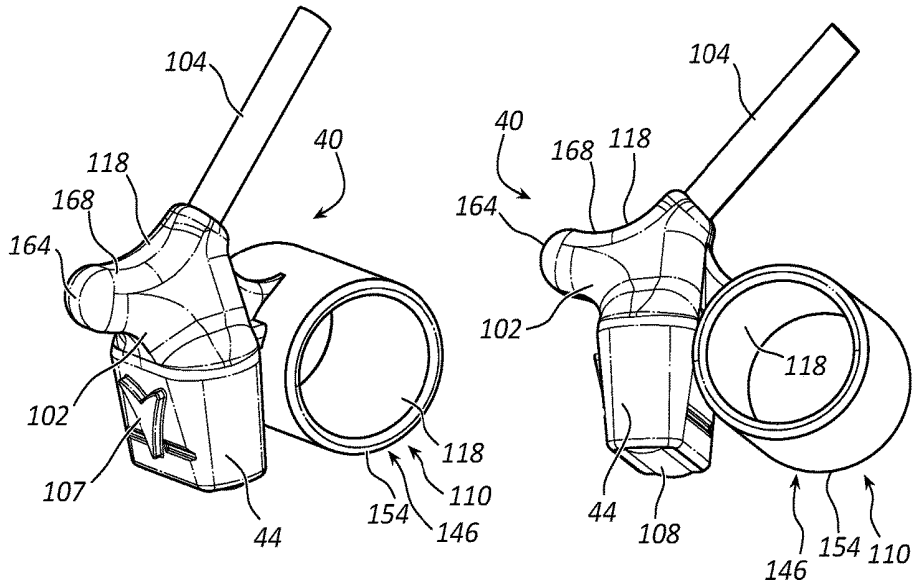

FIG. 10A

FIG. 10B

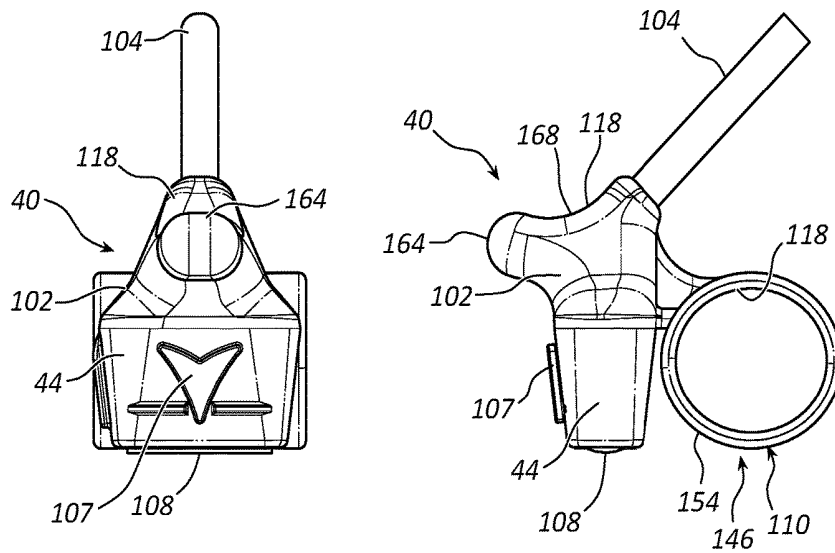

FIG. 10C

FIG. 10D

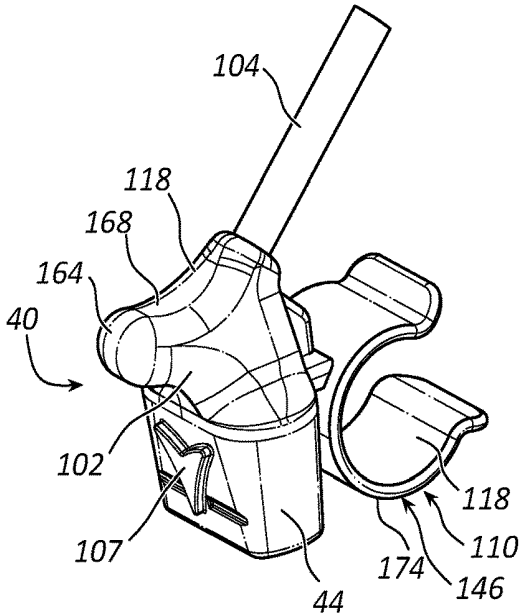

FIG. 11A

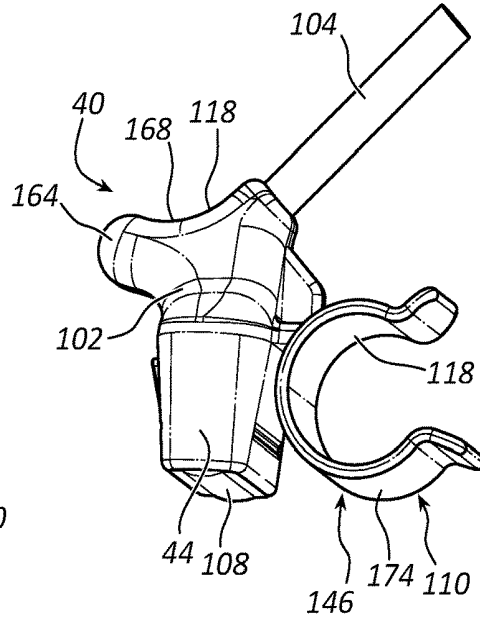

FIG. 11B

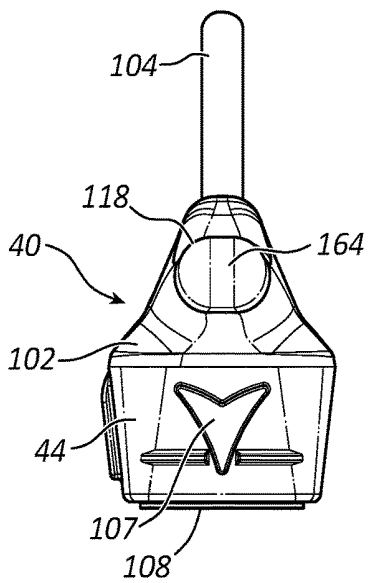

FIG. 11C

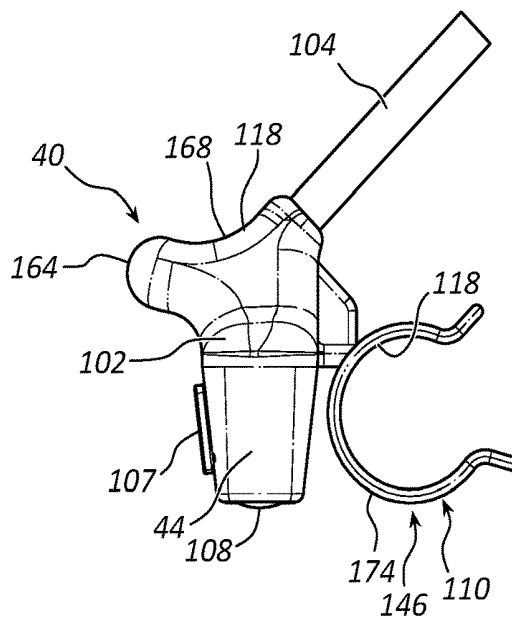

FIG. 11D

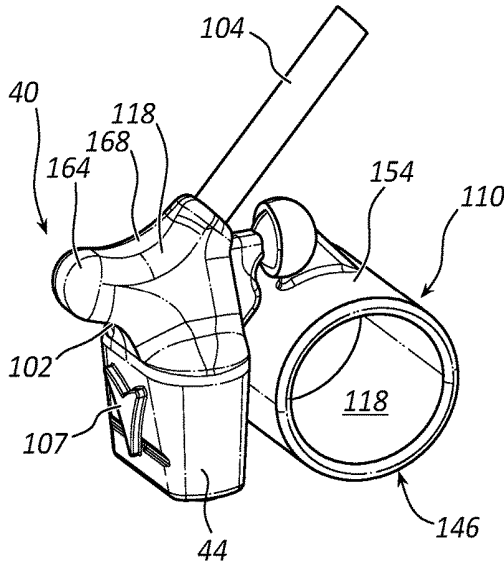

FIG. 12A

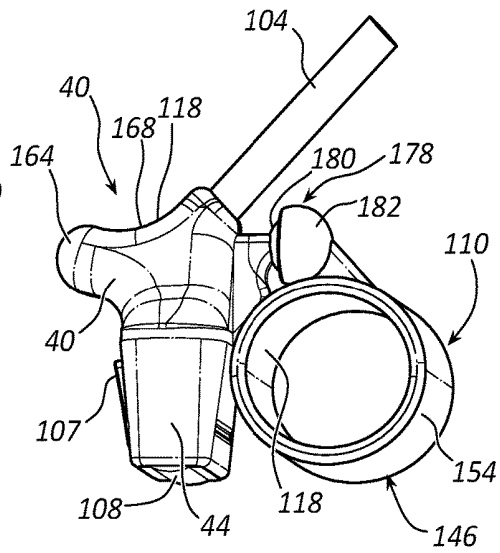

FIG. 12B

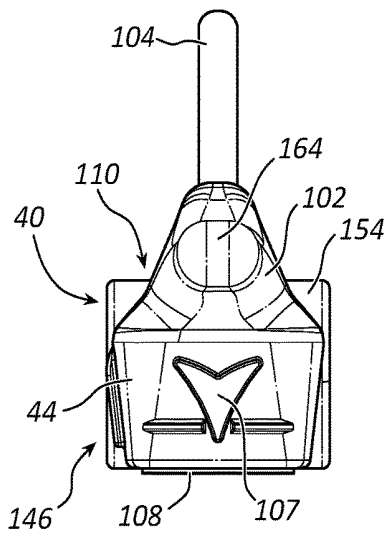

FIG. 12C

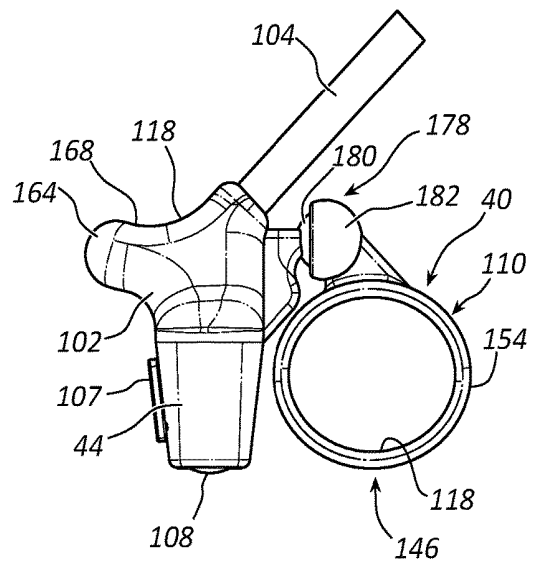

FIG. 12D

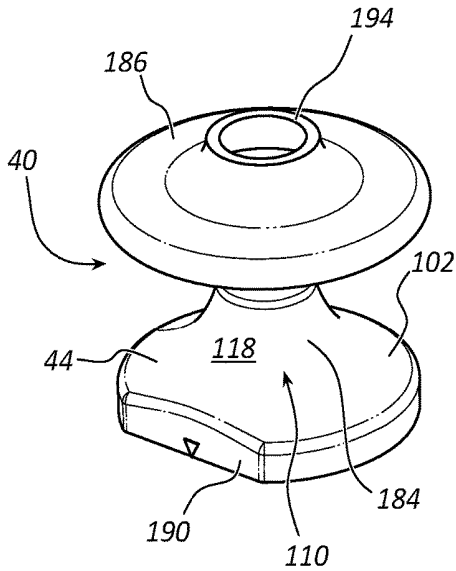

FIG. 13A

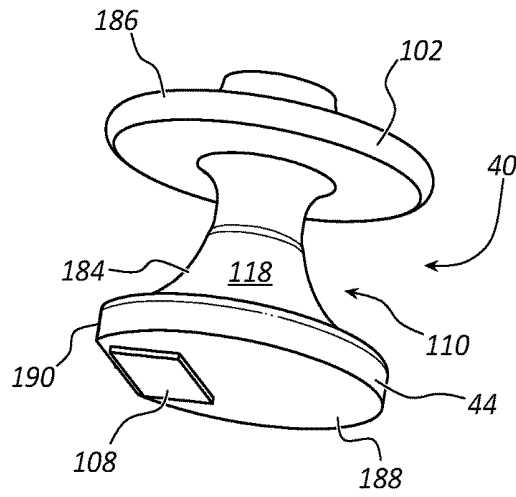

FIG. 13B

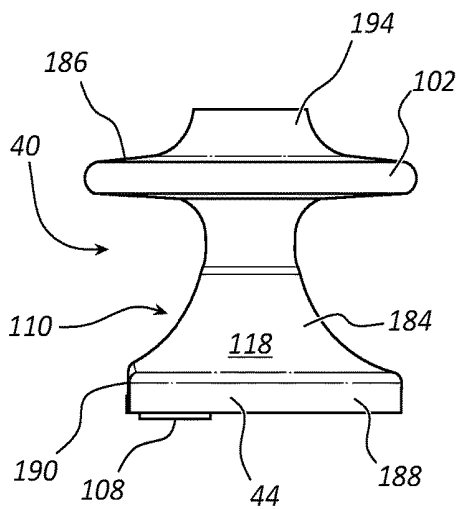

FIG. 13C

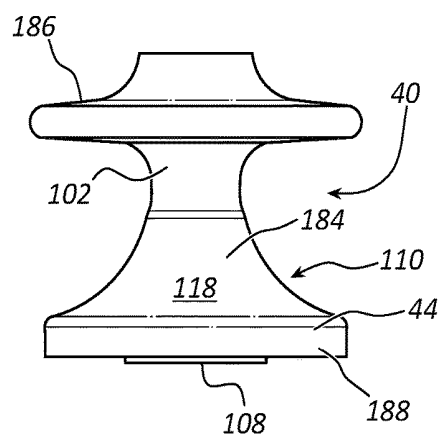

FIG. 13D

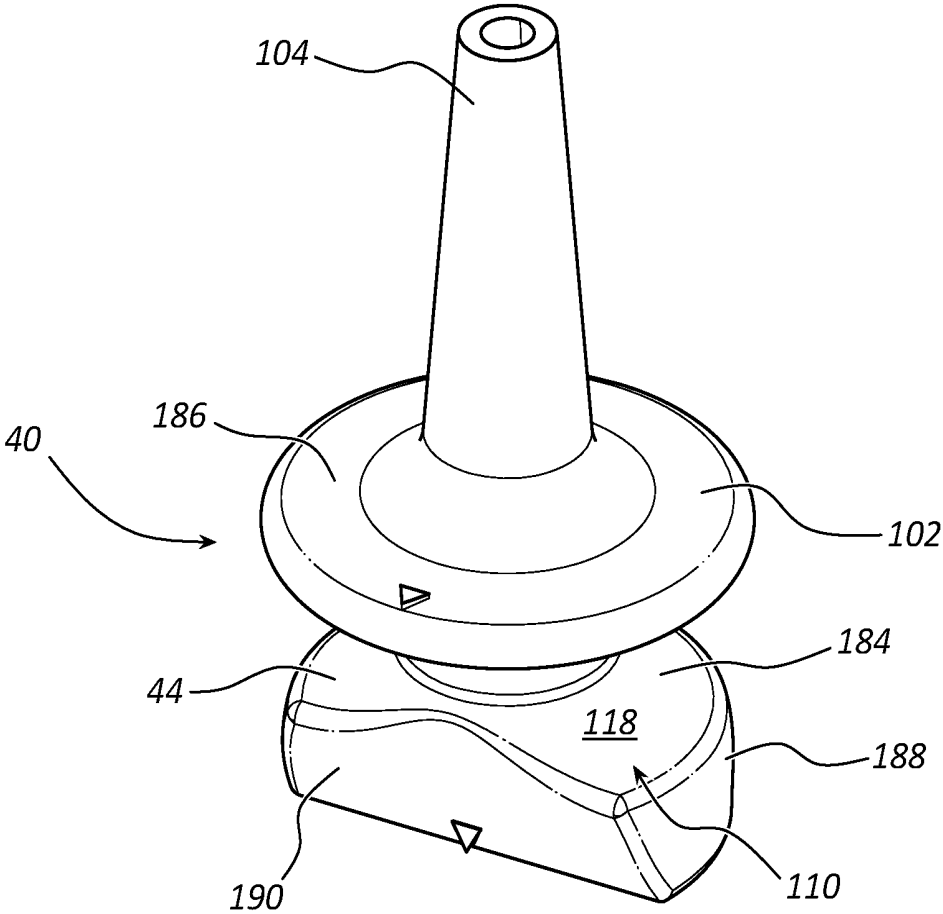

FIG. 14

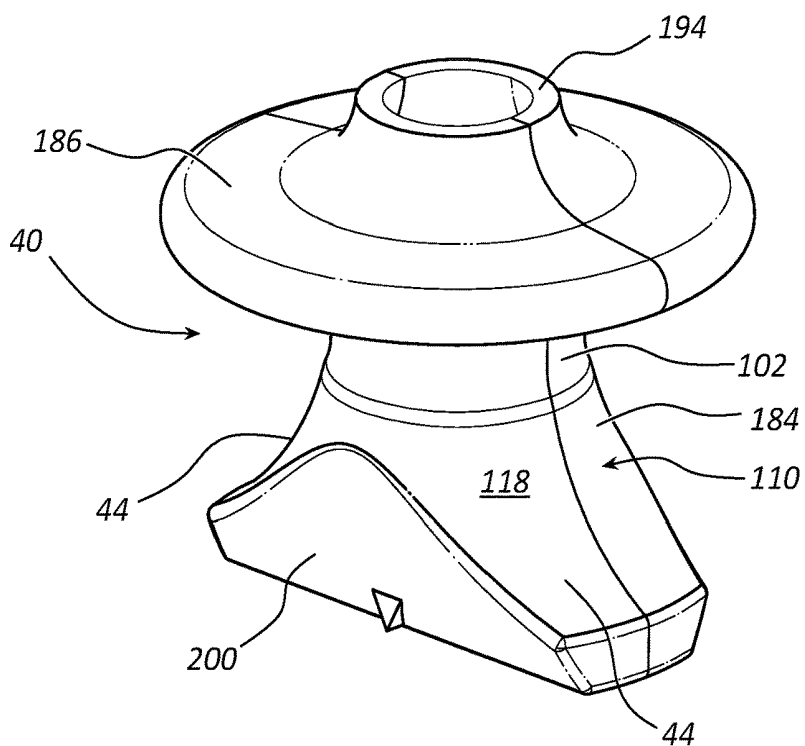

FIG. 15A

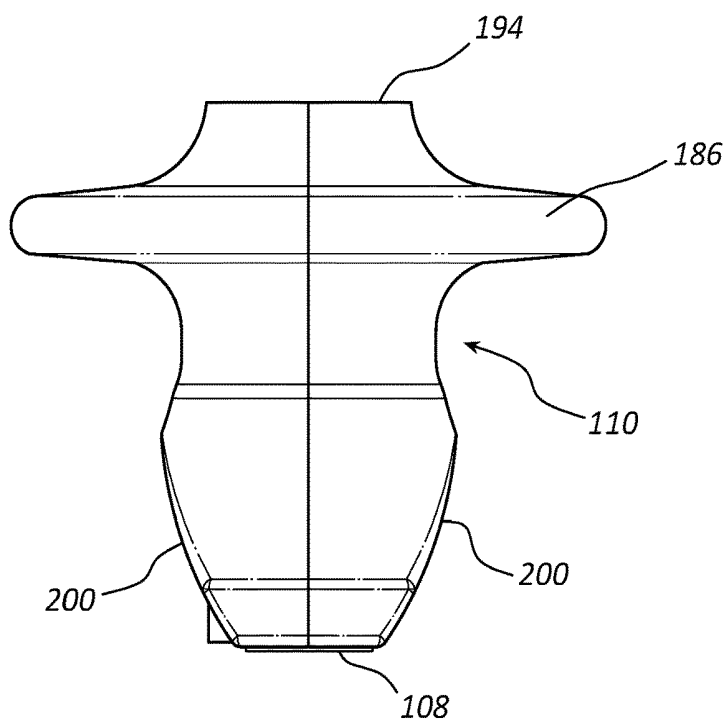

FIG. 15B

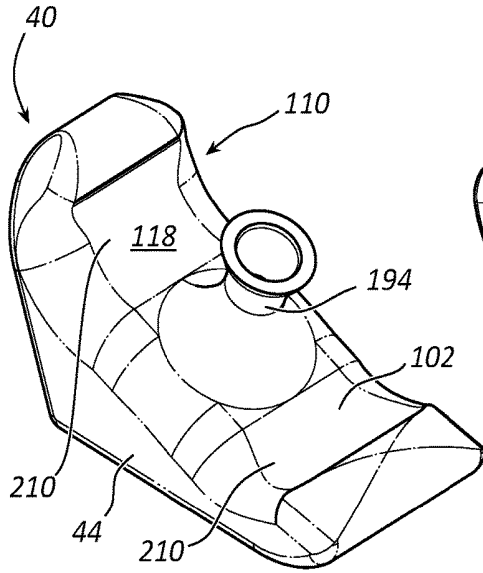

FIG. 16A

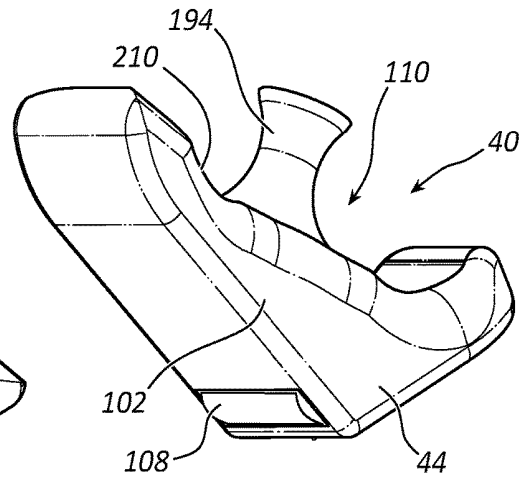

FIG. 16B

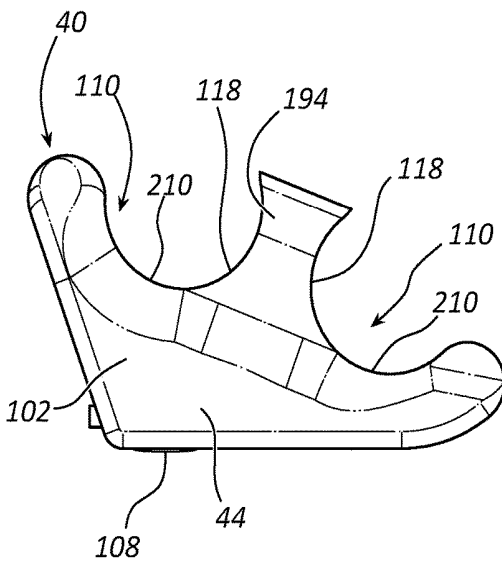

FIG. 16C

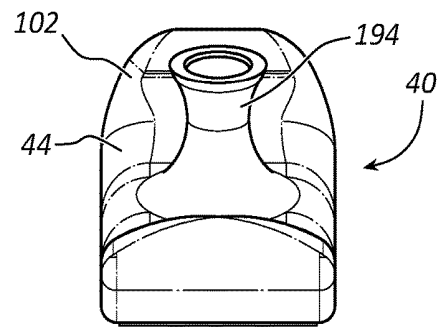

FIG. 16D

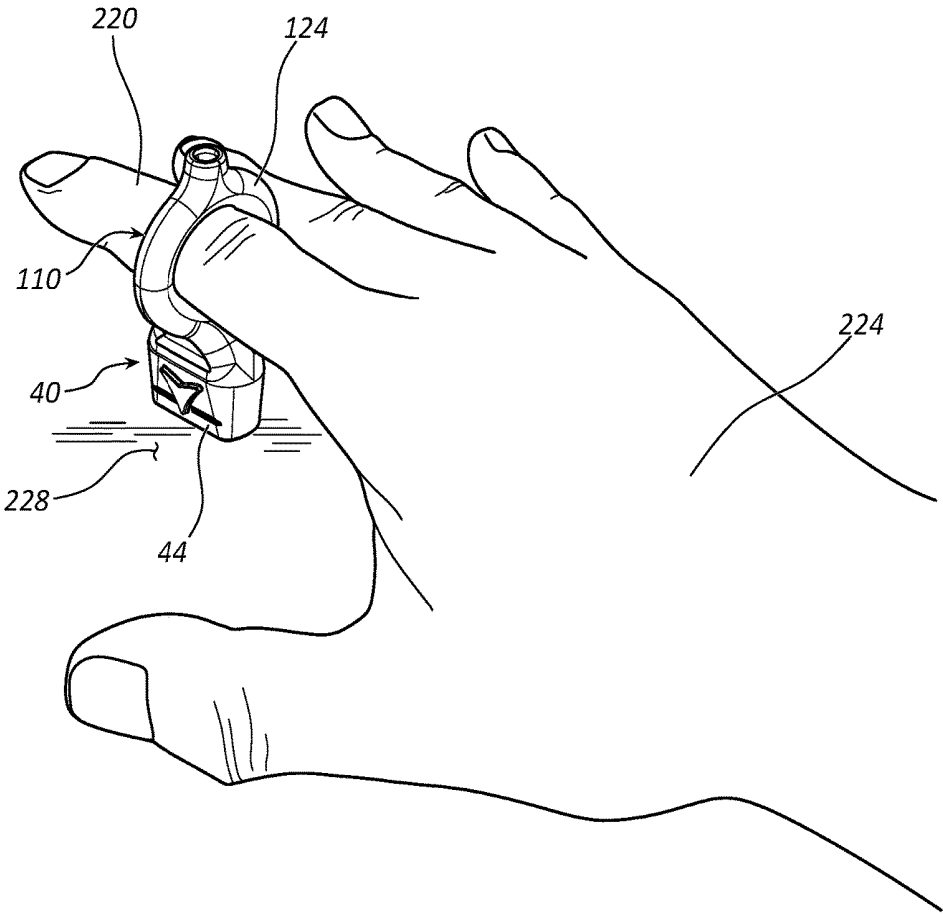

FIG. 17

ULTRASOUND FINGER PROBE**CROSS-REFERENCE TO RELATED APPLICATIONS**

[0001] This application claims the benefit of U.S. Provisional Patent Application No. 62/558,234, filed Sep. 13, 2017, and entitled “Ultrasound Finger Probe,” which is incorporated herein by reference in its entirety.

BRIEF SUMMARY

[0002] Briefly summarized, embodiments of the present invention are directed to an ultrasound probe (“probe”) for use with an ultrasound imaging system. In particular, the probe is sized and configured so as to be supported and readily used with as little as one finger on a single hand of a user of the imaging system, such as a clinician. This configuration enables remaining fingers on the hand of the user to be employed for other purposes, including applying traction to the skin surface of the patient proximate the imaging site and providing touch comfort to the patient. With it supported by as little as a single finger, the probe can easily be positioned by the user in a proper orientation against the skin surface during imaging procedures.

[0003] Further, the probe is configured in one embodiment to enable the user’s hand to be positioned substantially horizontally with respect to (parallel to) the skin surface of the patient, thus enabling relatively accurate probe positioning (e.g., lifting, placing, pressing, etc.) and scanning operations to be performed.

[0004] In one embodiment, the probe also includes a stabilizing portion to assist in maintaining stability of the probe while on the skin surface.

[0005] In one embodiment, therefore, an ultrasound probe is disclosed, comprising a body, a lens included on head portion of the body through which ultrasound signals can be passed, a stabilizing portion extending from the body and configured to stabilize the body on a skin surface of a patient without user assistance, and a finger grip portion configured to enable a user of the probe to grasp and maneuver the probe during use thereof with no more than two fingers on a single hand of the user.

[0006] These and other features of embodiments of the present invention will become more fully apparent from the following description and appended claims, or may be learned by the practice of embodiments of the invention as set forth hereinafter.

BRIEF DESCRIPTION OF THE DRAWINGS

[0007] A more particular description of the present disclosure will be rendered by reference to specific embodiments thereof that are illustrated in the appended drawings. It is appreciated that these drawings depict only typical embodiments of the invention and are therefore not to be considered limiting of its scope. Example embodiments of the invention will be described and explained with additional specificity and detail through the use of the accompanying drawings in which:

[0008] FIG. 1 is a perspective view of an ultrasound imaging system and included probe according to one embodiment;

[0009] FIG. 2 is a block diagram the ultrasound imaging system of FIG. 1;

[0010] FIGS. 3A-3D are various views of an ultrasound probe according to one embodiment;

[0011] FIGS. 4A-4D are various views of an ultrasound probe according to one embodiment;

[0012] FIG. 5A-5D are various views of an ultrasound probe according to one embodiment;

[0013] FIGS. 6A-6E are various views of an ultrasound probe according to one embodiment;

[0014] FIGS. 7A-7D are various views of an ultrasound probe according to one embodiment;

[0015] FIGS. 8A-8D are various views of an ultrasound probe according to one embodiment;

[0016] FIGS. 9A-9D are various views of an ultrasound probe according to one embodiment;

[0017] FIGS. 10A-10D are various views of an ultrasound probe according to one embodiment;

[0018] FIGS. 11A-11D are various views of an ultrasound probe according to one embodiment;

[0019] FIGS. 12A-12D are various views of an ultrasound probe according to one embodiment;

[0020] FIGS. 13A-13D are various views of an ultrasound probe according to one embodiment;

[0021] FIG. 14 is a perspective view of an ultrasound probe according to one embodiment;

[0022] FIGS. 15A and 15B are various views of an ultrasound probe according to one embodiment;

[0023] FIGS. 16A-16D are various views of an ultrasound probe according to one embodiment; and

[0024] FIG. 17 is a perspective view showing the hand of a user engaged with an ultrasound probe.

DETAILED DESCRIPTION OF SELECTED EMBODIMENTS

[0025] Reference will now be made to figures wherein like structures will be provided with like reference designations. It is understood that the drawings are diagrammatic and schematic representations of exemplary embodiments of the present invention, and are neither limiting nor necessarily drawn to scale.

[0026] For clarity it is to be understood that the word “proximal” refers to a direction relatively closer to a clinician using the device to be described herein, while the word “distal” refers to a direction relatively further from the clinician. For example, the end of a catheter placed within the body of a patient is considered a distal end of the catheter, while the catheter end remaining outside the body is a proximal end of the catheter. Also, the words “including,” “has,” and “having,” as used herein, including the claims, shall have the same meaning as the word “comprising.”

[0027] Embodiments of the present invention are generally directed to an ultrasound probe (“probe”) for use with an ultrasound imaging system. In particular, the probe is sized and configured so as to be supported and readily used with one or more fingers on a single hand of a user of the imaging system, such as a clinician. This configuration enables remaining fingers on the hand of the user to be employed for other purposes, including applying traction to the skin surface of the patient proximate the imaging site, providing touch comfort to the patient, etc. With it supported by as little as a single finger, the probe can easily be positioned by the user in a proper orientation against the skin surface during imaging procedures.

[0028] Further, the probe is configured in one embodiment to enable the user's hand to be positioned substantially horizontally with respect to (i.e., parallel to) the skin surface of the patient, thus enabling relatively accurate probe positioning (e.g., lifting, placing, pressing, etc.) and scanning operations to be performed.

[0029] In one embodiment, the probe also includes a stabilizing portion to assist in maintaining stability of the probe while on the skin surface.

[0030] In one embodiment, the probe is configured to be supported and manipulated by a single finger, with the finger positioned directly over a lens portion of the probe. Such a position enables the user to easily and accurately move the probe on the skin surface as to position the probe with subtle movements as desired.

[0031] FIG. 1 shows various components of an ultrasound imaging system 10 (also referred to herein as "imaging system" or "system"), according to one embodiment. As shown, the system 10 includes a console 20 housing various electronic and other components necessary for processing and depicting ultrasonic images. The console 20 includes a touchscreen display 30 for depicting ultrasonic images and for enabling touch-based input by a clinician to control the device and its functionality. An ultrasound probe ("probe") 40, containing one or more transducer elements in a head 44 thereof for emitting and receiving ultrasonic signals, is operably attached to the console 20 via a cable or other suitable interface, including wireless connectivity.

[0032] In one embodiment, an optional cap including a hydrogel insert can be removably attached to the head 44 of the probe 40 so as to cover a lens portion thereof. The hydrogel insert provides an ultrasonically transparent interface between the probe head 44 and the skin surface. A needle guide can also be included with the cap to assist with guiding needles through the patient's skin and into the vessel being imaged by the system 10. In another embodiment, the needle guide is included on the probe itself. Further details regarding the probe cap, hydrogel insert, and needle guide can be found in U.S. patent application Ser. No. 13/206,396, filed Aug. 9, 2011, and entitled "Support and Cover Structures for an Ultrasound Probe Head," and Ser. No. 13/531,406, filed Jun. 22, 2012, and entitled "Needle Guide with Selectable Aspects." Each of the foregoing applications is incorporated herein by reference in its entirety. In yet another embodiment, a sheath or cover can be removably placed over the probe 40 to provide a sterile barrier. Note that other ultrasound imaging devices and systems that differ from that shown here can also benefit from the embodiments described herein.

[0033] FIG. 2 shows a block diagram of the system 10 of FIG. 1, according to one embodiment. In detail, the console 20, display 30, and probe 40 are represented, as in FIG. 1. The console 20 includes therein a motherboard 64 for governing system functionality and includes a processor or other general or special purpose computer, memory, storage locations, and other components for system operation. A beamformer 65, including suitable circuitry, is also operably included with the motherboard 64 to enable ultrasonic signals to be produced, received, and processed. A power button 66 is included, as are USB ports 68 for interfacing with other devices. An external power supply 70, as well as a battery 72 and speaker 74, are provided for operation. The display 30 in the present embodiment includes an LCD screen 78 or other suitable screen, and a touchscreen 80 to

enable touch-based functionality via the display 30. Note that the system 10 can include different, fewer, or more components than those listed here, including those components that enable the system to operate in a networked manner with other local or remote computing or network systems, including for instance, Wi-Fi, Ethernet, Bluetooth, and ZigBee functionality. Also, in addition to a touchscreen, other input modes can also be employed, including a keyboard or mouse input, for instance.

[0034] In operation of the system 10, a lens portion of the head 44 of the probe 40 is placed against the skin of the patient so as to ultrasonically image a cross-sectional slice of a vessel, such as a vein, or other internal body tissue of the patient below the surface of the skin. Indeed, a target location of the vessel imaged by the probe 40 is disposed a substantially vertical depth below the end of the probe. The vessel is imaged by the system 10 in preparation for accessing the vessel with a needle in preparation for inserting a catheter into the vessel, in one embodiment. Though shown here as a vessel, the target location can be any one of various subcutaneous locations within the body.

[0035] FIGS. 3A-3D depict various features of the probe 40 including the head 44 thereof, in accordance with one embodiment. As shown, the probe 40 includes a body 102 defining lateral surfaces 102A and end surfaces 102B, with the head 44 of the probe defining a distal end of the probe body. A lens 108 is disposed at the distal end of the probe body 102 and is configured to enable passage therethrough of ultrasonic signals. An orientation arrow 107 is included in the illustrated embodiment to assist a user of the imaging system in determining proper needle placement through the skin surface of a patient. A cable 104 is shown extending from a proximal end of the probe body 102 to operably connect the probe to the console 20 (FIG. 1), though the cable can extend from the probe in accordance with various different configurations.

[0036] In the present embodiment, the probe 40 includes a finger grip portion 110 configured to enable the user of the probe to grasp, support, and handle the probe with one or more fingers of a single hand of the user while leaving one or more fingers of the user's hand free to be used in other ways. In the present embodiment, the finger grip portion 110 includes two angled, protruding elements 114 extending from the opposing lateral surfaces 120A of the probe body 102. Each of the protruding elements 114 defines, together with a proximate portion of the lateral surface 102A of the probe body 102, a concavely shaped grip surface 118 into which a user's finger is received in order to support and move the probe 40 during imaging system operation.

[0037] In the present embodiment, the probe 40 is placed between a forefinger (index finger) and a middle finger of a single hand of the user such that an inside portion of the forefinger engages one of the grip surfaces 118 and an inside portion of the middle finger engages the other grip surface on the opposing side of the probe. In this way, the user is able to lift, maneuver, slide, and otherwise move the probe 40 with only two fingers during operation of the imaging system 10. Note that other fingers of the user's hand can alternatively be used to hold the probe 40. This further enables the remaining three fingers of the user's hand to be employed in other ways during ultrasonic imaging by the probe 40. These other ways include, for instance, applying

traction to the skin surface, touching the patient in order to impart comfort, establishing or marking a physical reference point etc.

[0038] Note that the engagement of the probe 40 by the hand of the user is such that the user's hand is positioned substantially parallel with respect to the skin surface of the patient, i.e., horizontally, in a typical imaging procedure. This in turn enables the user to move the probe accurately and easily, with relatively small movements across the skin surface, which results in improved imaging results. Note also that the probe body 102 in this and other embodiments includes a suitable material, such as a thermoplastic. In one embodiment, the material includes R-5100 polyphenylsulfone.

[0039] Reference is now made to FIGS. 4A-4D, which depict various details of the probe 40 and its finger grip portion 110 for enabling grasping, supporting, and handling of the probe with one or more fingers of a single hand of the user while leaving one or more fingers of the user's hand free to be used in other ways as described herein, according to another embodiment. As shown, the finger grip portion 110 includes a ring 124 defined by the body 102 of the probe 40. The ring 124 is sized in one embodiment to receive a finger of the user, such as the forefinger or middle finger. To that end, an inner annular surface of the ring 124 serves as a grip surface 118 against which the user's finger rests to enable the finger to handle and control movement of the probe 40. It is thus noted that the finger grip portion 110, i.e., the ring 124 in the present embodiment, further serves as one example of a retention portion to retain engagement of the probe 40 with the user's finger(s). Note that, in this and other embodiments, the retention portion enables the probe 40 to remain attached with the finger of the user even when the finger and/or hand of the user is lifted from the skin surface, which enables the user to perform other tasks without putting down the probe.

[0040] In one embodiment, the size of the ring 124 can be configured such that the user's finger can be inserted varying distances through the ring in order to encounter a fit suitable for moving and handling the probe 40. As such, the ring 124 can be sized in one or more of varying diameters. In another embodiment, an insert can be removably fitted in to the ring 124 to adjust the size of the ring opening to accommodate differently sized fingers. Note that in one embodiment, all or part of the finger grip portion can be flexible/resilient so as to deform to a user's finger. Note also, that the probe 40 in the embodiment illustrated in FIGS. 4A-4D is about 2.5 inches high, the probe head 44 about 1 inch wide, and the ring 124 about 1.5 inches wide, though other dimensions are possible for this and the other embodiments described herein.

[0041] FIG. 17 shows the probe 40 of FIGS. 4A-4D engaged with a forefinger 220 of a hand 224 of a user in one use embodiment. As shown, the finger grip portion 110, i.e., the ring 124, enables the user's finger to be positioned substantially co-linearly above and in a spaced-apart relationship with respect to the lens 108 of the probe head 44 when the probe is in an operable position on a horizontal skin surface of the patient 228. This enables the user to impart relatively fine amounts of pressure, or traction, to the skin surface via pressing down the probe 40 thereon, and provides enhanced control over the probe. Also shown in FIG. 17 is the manner in which the hand of the user is positioned substantially parallel with respect to the skin

surface of the patient, i.e., horizontally, in a typical imaging procedure. As mentioned, this enables the user to move the probe accurately and easily, with relatively small movements across the skin surface, which results in improved imaging results.

[0042] Reference is now made to FIGS. 5A-5D, which depict various details of the probe 40 and its finger grip portion 110 for enabling grasping, supporting, and handling of the probe with one or more fingers of a single hand of the user while leaving one or more fingers of the user's hand free to be used in other ways, according to another embodiment. As shown, the finger grip portion 110 includes a hook 134 defined by the body 102 of the probe 40. The hook 134 is approximately C-shaped and is sized in one embodiment to receive a finger of the user, such as the forefinger or middle finger, while enabling an opening for ease of finger insertion/removal. An inner surface of the hook 134 serves as the grip surface 118 against which the user's finger rests to enable the finger to handle and control movement of the probe 40. It is thus noted that the finger grip portion 110, i.e., the hook 134 in the present embodiment, further serves as one example of a retention portion to retain engagement of the probe 40 with the user's finger(s).

[0043] In one embodiment, the size of the hook 134 can be configured such that different portions of the user's finger can be inserted into the hook in order to encounter a fit suitable for moving and handling the probe 40. As such, the hook 134 can be sized in one or more of varying sizes. In another embodiment, an insert can be removably fitted in to the hook 134 to adjust the size thereof to accommodate differently sized fingers.

[0044] The finger grip portion 110, i.e., the hook 134 in the embodiment of FIGS. 5A-5D, enables the user's finger to be positioned substantially co-linearly above and in a spaced-apart relationship with respect to the lens 108 of the probe head 44. This enables the user to impart relatively fine amounts of pressure, or traction, to the skin surface via pressing down the probe 40 thereon, and provides enhanced control over the probe.

[0045] Reference is now made to FIGS. 6A-6E, which depict various details of the probe 40 and its finger grip portion 110 for enabling grasping, supporting, and handling of the probe with one or more fingers of a single hand of the user while leaving one or more fingers of the user's hand free to be used in other ways, according to another embodiment. As shown, the finger grip portion 110 includes a tab 144 extending from one of the lateral surfaces 102A of the probe body 102. A terminal portion of the tab 144 includes an upwardly angled lip so as to provide the grip surface 118 on which a finger of the user, such as the forefinger, can rest. Another finger, such as the middle finger on the same hand of the user, can engage the opposing lateral surface 102A of the probe body 102 to enable the two fingers to handle and control movement of the probe 40. Note that other fingers can be employed to grasp the probe 40, as with the other embodiments herein.

[0046] The probe 40 of the embodiment of FIGS. 6A-6E further includes a stabilizing portion 146 configured to maintain the probe in an upright, usable position on the skin surface of the patient even when the user's hand is not contacting the probe. In the present embodiment, the stabilizing portion 146 includes an angled leg 148 extending from the lateral surface 102A opposite the tab 144, best seen in FIG. 6D. The leg 148 extends downward (from the

perspective shown in FIG. 6D) so as to provide a lower surface substantially flush with the lens 108 of the probe head 44. In this way, the leg 148 stabilizes the probe 40 by providing a second contacting surface for the skin, in addition to the lens 108. Note that the stabilizing portion 146 can also enable the probe 40 to be manipulated by a single finger, in one embodiment. A terminal free end of the leg 148 defines a notch 150, in the present embodiment, the notch configured for removably holding a portion of the cable 104 to keep it away from the hand of the user during use of the probe 40.

[0047] Reference is now made to FIGS. 7A-7D, which depict various details of the probe 40 and its finger grip portion 110 for enabling grasping, supporting, and handling of the probe with one or more fingers of a single hand of the user while leaving one or more fingers of the user's hand free to be used in other ways, according to another embodiment. As shown, the finger grip portion 110 includes a cylindrical ring 154 extending from the main body 102 of the probe 40. The cylindrical ring 154 is sized in one embodiment to receive a finger of the user, such as the forefinger or middle finger. To that end, an inner cylindrical surface of the ring 154 serves as the grip surface 118 against which the user's finger rests to enable the finger to handle and control movement of the probe 40. It is thus noted that the finger grip portion 110, i.e., the cylindrical ring 154 in the present embodiment, further serves as one example of a retention portion to retain engagement of the probe 40 with the user's finger(s).

[0048] In one embodiment, the size of the cylindrical ring 154 can be configured such that the user's finger can be inserted varying distances through the ring in order to encounter a fit suitable for moving and handling the probe 40. As such, the cylindrical ring 154 can be sized in one or more of varying diameters. In another embodiment, an insert can be removably fitted in to the cylindrical ring 154 to adjust the size of the ring opening to accommodate differently sized fingers. In yet another embodiment, the cylindrical ring 154 can have a varying diameter, such as being relatively wider at either end, so as to introduce freedom of movement for a finger inserted therein.

[0049] The probe 40 of the embodiment of FIGS. 7A-7D further includes the stabilizing portion 146 configured to maintain the probe in an upright, usable position on the skin surface of the patient even when the user's hand is not contacting the probe. In the present embodiment, the stabilizing portion 146 includes the cylindrical ring 154 itself, best seen in FIG. 7D. The cylindrical ring 154 extends downward (from the perspective shown in FIG. 7D) so as to provide a lower surface substantially flush with the lens 108 of the probe head 44. In this way, the bottom portion of the cylindrical ring 154 stabilizes the probe 40 by providing a second contacting surface for the skin, in addition to the lens 108.

[0050] Reference is now made to FIGS. 8A-8D, which depict various details of the probe 40 and its finger grip portion 110 for enabling grasping, supporting, and handling of the probe with one or more fingers of a single hand of the user while leaving one or more fingers of the user's hand free to be used in other ways, according to another embodiment.

[0051] As shown, the finger grip portion 110 includes the cylindrical ring 124 extending from the body 102 of the probe 40. The cylindrical ring 154 is sized in one embodi-

ment to receive a finger of the user, such as the forefinger or middle finger. To that end, an inner cylindrical surface of the cylindrical ring 154 serves as the grip surface 118 against which the user's finger rests to enable the finger to handle and control movement of the probe 40. It is thus noted that the finger grip portion 110, i.e., the cylindrical ring 154 in the present embodiment, further serves as one example of a retention portion to retain engagement of the probe 40 with the user's finger(s).

[0052] In one embodiment, the size of the cylindrical ring 154 can be configured such that the user's finger can be inserted varying distances through the ring in order to encounter a fit suitable for moving and handling the probe 40. As such, the cylindrical ring 154 can be sized in one or more of varying diameters. In another embodiment, an insert can be removably fitted in to the cylindrical ring 154 to adjust the size of the ring opening to accommodate differently sized fingers.

[0053] The finger grip portion 110, i.e., the cylindrical ring 154 in the embodiment of FIGS. 8A-8D, enables the user's finger to be positioned substantially co-linearly above and in a spaced-apart relationship with respect to the lens 108 of the probe head 44. This enables the user to impart relatively fine amounts of pressure, or traction, to the skin surface via pressing down the probe 40 thereon, and provides enhanced control over the probe.

[0054] Note in the present embodiment that the cable 104, which operably connects the probe 40 to the console 20 (FIG. 1), extends from the probe body 102 at an angle from the use position of the probe (i.e., from the perspective shown in FIG. 8D). This cable configuration can reduce torque on the probe 40 by the cable 104 as well as keep the cable clear of the user's hand. Such a configuration can be included in other of the embodiments described herein.

[0055] Reference is now made to FIGS. 9A-9D, which depict various details of the probe 40 and its finger grip portion 110 for enabling grasping, supporting, and handling of the probe with one or more fingers of a single hand of the user while leaving one or more fingers of the user's hand free to be used in other ways, according to another embodiment.

[0056] As shown, the embodiment of FIGS. 9A-9D is similar to that shown in FIGS. 8A-8D, with the addition of the stabilizing portion 146—here, the angled leg 148 similar to that shown in the embodiment of FIGS. 6A-6E. Note that the particular shape of the angled leg 148 of FIGS. 9A-9D differs in shape somewhat from the angled leg of FIGS. 6A-6E, while still being configured to maintain the probe in an upright, usable position on the skin surface of the patient even when the user's hand is not contacting the probe. As before, the angled leg 148 extends downward (from the perspective shown in FIG. 9D) so as to provide a lower surface substantially flush with the lens 108 of the probe head 44. In this way, the leg 148 stabilizes the probe 40 by providing a second contacting surface for the skin, in addition to the lens 108.

[0057] Reference is now made to FIGS. 10A-10D, which depict various details of the probe 40 and its finger grip portion 110 for enabling grasping, supporting, and handling of the probe with one or more fingers of a single hand of the user while leaving one or more fingers of the user's hand free to be used in other ways, according to another embodiment. As shown, the finger grip portion 110 includes a cylindrical ring 154 extending from the main body 102 of

the probe 40. The cylindrical ring 154 is sized in one embodiment to receive a first finger of the user, such as the middle finger. To that end, an inner cylindrical surface of the ring 154 serves as the grip surface 118 against which the user's finger rests to enable the finger to handle and control movement of the probe 40. It is thus noted that the finger grip portion 110, i.e., the cylindrical ring 154 in the present embodiment, further serves as one example of a retention portion to retain engagement of the probe 40 with the user's finger(s).

[0058] In one embodiment, the size of the cylindrical ring 154 can be configured such that the user's finger can be inserted varying distances through the ring in order to encounter a fit suitable for moving and handling the probe 40. As such, the cylindrical ring 154 can be sized in one or more of varying diameters. In another embodiment, an insert can be removably fitted in to the cylindrical ring 154 to adjust the size of the ring opening to accommodate differently sized fingers.

[0059] The probe body 102 further defines a protrusion 164 and a saddle 168 to provide a second grip surface 118 on which a second finger of the user's hand, such as the forefinger, can rest to further support and handle the probe 40. Thus, two fingers of a user's single hand can be employed in the present embodiment to support and use the probe 40. The saddle 168 enables the user's finger to be positioned substantially co-linearly above and in a spaced-apart relationship with respect to the lens 108 of the probe head 44. This enables the user to impart relatively fine amounts of pressure, or traction, to the skin surface via pressing down the probe 40 thereon, and provides enhanced control over the probe.

[0060] The probe 40 of the embodiment of FIGS. 10A-10D further includes the stabilizing portion 146 configured to maintain the probe in an upright, usable position on the skin surface of the patient even when the user's hand is not contacting the probe. In the present embodiment, the stabilizing portion 146 includes the cylindrical ring 154 itself, best seen in FIG. 10D. The cylindrical ring 154 extends downward (from the perspective shown in FIG. 10D) so as to provide a lower surface substantially flush with the lens 108 of the probe head 44. In this way, the bottom portion of the cylindrical ring 154 stabilizes the probe 40 by providing a second contacting surface for the skin, in addition to the lens 108.

[0061] Reference is now made to FIGS. 11A-11D, which depict various details of the probe 40 and its finger grip portion 110 for enabling grasping, supporting, and handling of the probe with one or more fingers of a single hand of the user while leaving one or more fingers of the user's hand free to be used in other ways, according to another embodiment.

[0062] As shown, the embodiment of FIGS. 11A-11D is similar to that shown in FIGS. 10A-10D, with the finger grip portion 110 including a cylindrical hook 174 extending from the probe body 102. The cylindrical hook 174 is approximately C-shaped and is sized in one embodiment to receive a finger of the user, such as the forefinger or middle finger, while enabling an opening for ease of finger insertion/removal. An inner surface of the hook 134 serves as the grip surface 118 against which the user's finger rests to enable the finger to handle and control movement of the probe 40. In one embodiment, the cylindrical hook 174 is resilient such that it can deform a limited amount to conform to the size of

the user's finger and remain connected therewith. It is thus noted that the finger grip portion 110, i.e., the hook 134 in the present embodiment, further serves as one example of a retention portion to retain engagement of the probe 40 with the user's finger(s).

[0063] Note that in one embodiment the cylindrical hook 174 can include an oval cross-sectional shape to further enhance its engagement with the user's finger. In one embodiment, excess material comprising a sterile cover that is draped over the probe 40 can be inserted into the interior portion of the cylindrical hook 174 in order to increase the engagement of the cylindrical hook with the user's finger (and note that this technique can be employed in connection with the other embodiments herein, including those depicted in FIGS. 4A, 5A, 7A, 8A, 9A, 10A, and 12A. In addition, the cylindrical hook 174 in one embodiment can be removable as to enable cylindrical rings or other finger retention portions of different sizes/configurations to be interchanged on the probe 40.

[0064] Also, as with the cylindrical ring 154 of the embodiment shown in FIGS. 10A-10D, the cylindrical hook 174 of the present embodiment serves as the stabilizing portion 146, configured to maintain the probe 40 in an upright, usable position on the skin surface of the patient even when the user's hand is not contacting the probe.

[0065] Reference is now made to FIGS. 12A-12D, which depict various details of the probe 40 and its finger grip portion 110 for enabling grasping, supporting, and handling of the probe with one or more fingers of a single hand of the user while leaving one or more fingers of the user's hand free to be used in other ways, according to another embodiment.

[0066] As shown, the embodiment of FIGS. 12A-12D is similar to that shown in FIGS. 10A-10D, with the finger grip portion 110 including the cylindrical ring 154, which further serves as the stabilizing portion 146. The embodiment shown in FIGS. 12A-12D includes an articulating component 178 disposed between the cylindrical ring 154 and the main portion of the probe body 102. In detail, the articulating component 178 includes a ball 180 included on the main portion of the probe body 102 and a corresponding socket 182 included on the cylindrical ring and sized to receive the ball therein so as to enable articulating movement between the probe head 44 and the cylindrical ring 154 through which a user's finger is received during an ultrasound imaging procedure. The articulating component 178 enables relative movement between the probe head 44 and the cylindrical ring, thus enabling freedom of movement of the probe 40. This is useful when it is desired to lift the lens 108 above the skin surface while desiring to keep one or more fingers on the skin surface. Note that other articulating and jointed structures can be employed to provide such relative movement, such as a hinge in one embodiment. Also, the ball and socket configuration can be reversed in position, in one embodiment.

[0067] Note that, in the present and previous embodiments discussed above, the probe head 44, lens 108, and orientation arrow 107 are configured similar to standard probe heads so as to lend familiarity to the user in terms of placement of the probe head and lens on the skin surface and inserting needles, etc.

[0068] Reference is now made to FIGS. 13A-13D, which depict various details of the probe 40 and its finger grip portion 110 for enabling grasping, supporting, and handling

of the probe with one or more fingers of a single hand of the user while leaving one or more fingers of the user's hand free to be used in other ways, according to another embodiment. As shown, the probe body **102** includes a top disk **186** and a bottom disk **188** that are separated by the finger grip portion **110**, here configured as an hourglass-shaped surface **184** that defines the grip surface **118**. Two fingers of a user's single hand, such as the forefinger and middle finger (though other digits could be used), can straddle the hourglass-shaped surface **184** to grasp and handle the probe **40**. A flat side surface **190** is included on the bottom disk **188** proximate the lens **108**, which is disposed on the bottom of the probe head **44**, from the perspective shown in FIGS. **13C** and **13D**. A cable can extend from a cable conduit **194** at a top surface of the probe body **102**. As in previous embodiments, the probe body design shown in the present embodiment enables a finger to be positioned substantially directly over the lens **108** in a spaced-apart arrangement. Note that the flat bottom surface of the bottom disk **188**, best seen in FIG. **13B**, serves as a stabilizing portion in the present embodiment for enabling the probe **40** to rest without assistance on the skin surface of the patient.

[0069] FIG. **14** depicts the probe **40** according to one embodiment. The probe **40** here is similar to that shown in the embodiment of FIGS. **13A-13D**, but with the flat side surface **190**, proximate the lens **108**, being relatively larger.

[0070] FIGS. **15A** and **15B** depict yet another variation of the embodiment shown in FIGS. **13A-13D**, wherein the bottom disk of the probe body **102** is omitted and two chamfered surfaces **200** are defined on a bottom portion of the probe body proximate the lens **108**. These and other variations to the probe body **102** while still enabling grasping and handling of the probe **40** with one or more fingers but while still enabling other fingers of the user's hand to be free for other purposes, are therefore contemplated.

[0071] FIGS. **16A-16D** depict various details of the probe **40** and its finger grip portion **110** for enabling grasping, supporting, and handling of the probe with one or more fingers of a single hand of the user while leaving one or more fingers of the user's hand free to be used in other ways, according to another embodiment. As shown, the probe body **102** includes a generally wedge-shaped configuration, with the lens **108** of the probe head **44** disposed on a bottom surface thereof, from the perspective shown in FIGS. **16C** and **16D**. Note that the flat bottom surface of the probe body **102**, best seen in FIG. **16B**, serves as a stabilizing portion in the present embodiment for enabling the probe **40** to rest without assistance on the skin surface of the patient.

[0072] The cable conduit **194** extends from the probe body **102** and two finger grip portions **110** are included, namely, two channels **210** that are defined by the body and are disposed adjacent the cable conduit so as to provide two concavely shaped grip surfaces **118**. Two fingers of a single hand of the user, such as the forefinger and middle finger, can be received into the channel **210** to support and handle the probe **40**, while enabling other fingers of the user's hand to be used for other purposes. These and other probe body shapes and finger grip portion configurations are therefore contemplated.

[0073] Note that the probes discussed herein are further configured to enable a sterile cover to be thereover and for elastic bands to be used to secure the cover to the probe. The

probes herein are also configured to be symmetrical along at least one midline axis so as to enable both left-handed and right-handed use.

[0074] In one embodiment, it is appreciated that icons/symbols may be placed on the probe body **102** to assist a user in knowing where to place finger(s) for use of the probe **40**.

[0075] Embodiments of the invention may be embodied in other specific forms without departing from the spirit of the present disclosure. The described embodiments are to be considered in all respects only as illustrative, not restrictive. The scope of the embodiments is, therefore, indicated by the appended claims rather than by the foregoing description. All changes that come within the meaning and range of equivalency of the claims are to be embraced within their scope.

What is claimed is:

1. An ultrasound probe, comprising:

a body;

a lens included on a head portion of the body through which ultrasound signals can be passed;

a stabilizing portion extending from the body configured to stabilize the body on a skin surface of a patient without user assistance; and

a finger grip portion configured to enable a user of the probe to grasp and maneuver the probe during use thereof with no more than two fingers on a single hand of the user.

2. The ultrasound probe as defined in claim 1, wherein the finger grip portion is configured to enable the user to grasp and maneuver the probe with a single finger.

3. The ultrasound probe as defined in claim 1, wherein the finger grip portion and the stabilizing portion are included in a singular structure.

4. The ultrasound probe as defined in claim 1, wherein the finger grip portion includes at least one of a ring structure and a C-shaped structure.

5. The ultrasound probe as defined in claim 4, wherein the stabilizing portion includes an arm extending from the body of the probe.

6. The ultrasound probe as defined in claim 4, wherein the stabilizing portion is included with the ring structure.

7. The ultrasound probe as defined in claim 4, wherein the ring structure defines a cylindrical ring.

8. The ultrasound probe as defined in claim 7, wherein the finger grip portion further includes a saddle portion configured to receive a finger thereon.

9. The ultrasound probe as defined in claim 1, wherein the finger grip portion is disposed substantially co-linearly above the lens in a spaced-apart configuration when the probe is positioned on the skin surface of the patient.

10. The ultrasound probe as defined in claim 1, wherein the finger grip portion includes a tab extending from the body of the probe and the stabilizing portion includes an angled arm extending from the body of the probe.

11. The ultrasound probe as defined in claim 1, wherein the finger grip portion is configured to be engaged by at least one of a forefinger and a middle finger of the hand of the user.

12. The ultrasound probe as defined in claim 1, wherein at least a thumb and a finger of the hand of the user are configured to be free to use when the hand of the user is grasping the probe.

13. The ultrasound probe as defined in claim 1, wherein an articulating component is interposed between the body of the probe and the stabilizing portion.

14. The ultrasound probe as defined in claim 13, wherein the articulating component includes a ball and socket configuration.

15. The ultrasound probe as defined in claim 1, wherein the stabilizing portion includes a bottom surface of the probe body proximate the lens.

16. The ultrasound probe as defined in claim 15, wherein the finger grip portion includes a hourglass-shaped surface bounded by a top disk and a bottom disk, wherein the hourglass-shaped surface, the top disk, and the bottom disk are defined by the body of the probe.

17. The ultrasound probe as defined in claim 15, wherein the finger grip portion includes first and second concave channels defined by the body of the probe, the probe defining a wedge shape.

18. The ultrasound probe as defined in claim 1, wherein the stabilizing portion is configured to maintain the body of the probe in an operable position without user assistance when the probe is placed on the substantially horizontal skin surface of the patient.

19. The ultrasound probe as defined in claim 1, wherein the finger grip portion is configured to enable the hand of the user to be positioned substantially parallel with respect to the skin surface of the patient.

20. An ultrasound probe, comprising:

a body defining first and second ends;

a lens, included on the second end of the body, through which ultrasound signals can be passed; and

a retention portion included proximate the first end of the body, and configured to enable a user of the probe to grasp and maneuver the probe during use thereof with a single finger on a hand of the user.

21. The ultrasound probe as defined in claim 20, wherein the retention portion is configured to receive the finger of the user therethrough.

22. The ultrasound probe as defined in claim 20, wherein the finger grip portion includes at least one of a ring structure and a C-shaped structure.

23. The ultrasound probe as defined in claim 22, further comprising a stabilizing portion extending from the body and configured to stabilize the body on a skin surface of a patient without user assistance.

24. The ultrasound probe as defined in claim 23, wherein the stabilizing portion includes an arm extending from the body of the probe.

25. The ultrasound probe as defined in claim 23, wherein the stabilizing portion is included with the retention portion.

26. The ultrasound probe as defined in claim 23, wherein the ring structure defines a cylindrical ring, the cylindrical ring defining a narrow central portion relative to either outer portion of the cylindrical ring.

27. The ultrasound probe as defined in claim 20, wherein the retention portion is disposed substantially co-linearly above the lens in a spaced-apart configuration when the probe is positioned on the skin surface of the patient.

28. The ultrasound probe as defined in claim 20, wherein the retention portion is configured to keep the probe attached to the hand of the user when the hand is lifted from the skin surface of the patient.

29. The ultrasound probe as defined in claim 20, wherein the probe body is symmetrical about at least one midline axis.

30. An ultrasound probe, comprising:

a body;

a lens included on the body through which ultrasound signals are passed; and

a finger grip portion configured to enable a user of the probe to grasp and handle the probe during use thereof with a single finger of the user, the finger grip portion positioned substantially co-linearly above the lens in a spaced-apart configuration when the probe is positioned on a horizontal skin surface of a patient.

31. The ultrasound probe as defined in claim 30, wherein the finger grip portion is configured to receive the finger of the user therethrough.

32. The ultrasound probe as defined in claim 31, wherein the finger grip portion includes at least one of a ring structure and a C-shaped structure.

33. The ultrasound probe as defined in claim 32, further comprising a stabilizing portion extending from the body and configured to stabilize the body on a skin surface of a patient without user assistance.

34. The ultrasound probe as defined in claim 33, wherein the stabilizing portion includes an arm extending from the body of the probe.

35. The ultrasound probe as defined in claim 33, wherein the stabilizing portion is included with the retention portion.

36. The ultrasound probe as defined in claim 33, wherein the ring structure defines a cylindrical ring.

37. The ultrasound probe as defined in claim 30, further including a cable configured to operably connect the probe to a console of an ultrasound imaging system, the cable extending from the probe at an angle with respect to a use position of the probe.

38. The ultrasound probe as defined in claim 30, wherein the finger grip portion is configured to enable the single finger of the user to exert a downward force on the skin surface of the patient.

39. An ultrasound imaging system, comprising:

a console;

a display included with the console; and

a probe as defined in claim 1 herein.

40. An ultrasound probe, comprising:

a body;

a lens included on a head portion of the body through which ultrasound signals can be passed; and

a finger grip portion configured to enable a user of the probe to grasp and maneuver the probe during use thereof with no more than two fingers on a single hand of the user, the finger grip portion including first and second concavely shaped finger grip surfaces on opposing sides of the body each correspondingly configured to receive a first and second finger of the hand of the user.

* * * * *

专利名称(译)	超声波手指探头		
公开(公告)号	US20190076121A1	公开(公告)日	2019-03-14
申请号	US16/130756	申请日	2018-09-13
[标]申请(专利权)人(译)	巴德阿克塞斯系统股份有限公司		
申请(专利权)人(译)	BARD接入系统, INC.		
当前申请(专利权)人(译)	BARD接入系统, INC.		
[标]发明人	SOUTHARD JEANETTE E PRINCE MATTHEW J ROBBINS TAB BECK KENT F		
发明人	SOUTHARD, JEANETTE E. PRINCE, MATTHEW J. ROBBINS, TAB CREAMER, TIMOTHY L. BECK, KENT F. WESTWOOD, PAUL T. LENGYEL, ANDREW J.		
IPC分类号	A61B8/00 A61B8/12		
CPC分类号	A61B8/4455 A61B8/4254 A61B8/54 A61B8/12 A61B8/4427		
优先权	62/558234 2017-09-13 US		
外部链接	Espacenet USPTO		

摘要(译)

公开了一种与超声成像系统一起使用的超声探头 (“探头”)。特别地, 探针的尺寸和构造被设计成在成像系统的用户的单手上被支撑并且容易使用少至一个手指。这种配置使得用户手上的剩余手指能够用于其他目的, 例如皮肤牵引和患者接触。因此, 在一个实施例中, 公开了一种超声探头, 包括主体, 包括在主体的头部上的镜片, 从主体延伸并且被配置为在没有用户帮助的情况下将身体稳定在患者的皮肤表面上的稳定部分, 手指握持部分, 被配置为使得探针的使用者能够在期间抓握并操纵探针, 并且在用户的单手上不超过两个手指。

