



(19) **United States**

(12) **Patent Application Publication**  
**Barthe et al.**

(10) **Pub. No.: US 2019/0184207 A1**  
(43) **Pub. Date: Jun. 20, 2019**

(54) **ULTRASOUND PROBE FOR TREATING SKIN LAXITY**

*G01S 15/89* (2006.01)

*A61B 8/12* (2006.01)

*A61B 8/13* (2006.01)

*A61B 8/00* (2006.01)

*A61N 7/00* (2006.01)

*A61H 23/02* (2006.01)

*A61B 17/32* (2006.01)

(71) Applicant: **Guided Therapy Systems, L.L.C.**,  
Mesa, AZ (US)

(72) Inventors: **Peter G. Barthe**, Phoenix, AZ (US);  
**Michael H. Slayton**, Phoenix, AZ (US);  
**Inder Raj S. Makin**, Mesa, AZ (US)

(21) Appl. No.: **16/284,907**

(22) Filed: **Feb. 25, 2019**

(52) **U.S. Cl.**

CPC ..... *A61N 7/02* (2013.01); *A61N 2007/027*  
(2013.01); *A61B 8/483* (2013.01); *G01S*  
*15/8909* (2013.01); *A61B 8/08* (2013.01);  
*A61B 8/0858* (2013.01); *A61B 8/12* (2013.01);  
*A61B 8/13* (2013.01); *A61B 8/4483* (2013.01);  
*A61B 8/461* (2013.01); *A61N 7/00* (2013.01);  
*A61H 23/0245* (2013.01); *A61B 17/320068*  
(2013.01); *A61B 8/546* (2013.01); *A61B 5/682*  
(2013.01); *A61B 8/4281* (2013.01); *A61B*  
*8/4455* (2013.01); *A61H 2201/5007* (2013.01);  
*A61B 8/4209* (2013.01); *A61N 2007/0008*  
(2013.01); *A61N 2007/0034* (2013.01); *A61N*  
*2007/0052* (2013.01); *A61B 5/6842* (2013.01)

**Related U.S. Application Data**

(63) Continuation of application No. 15/996,255, filed on Jun. 1, 2018, now Pat. No. 10,265,550, which is a continuation of application No. 15/821,070, filed on Nov. 22, 2017, now Pat. No. 10,010,724, which is a continuation of application No. 15/625,700, filed on Jun. 16, 2017, now Pat. No. 9,827,449, which is a continuation of application No. 15/248,407, filed on Aug. 26, 2016, now Pat. No. 9,694,211, which is a continuation of application No. 14/692,114, filed on Apr. 21, 2015, now Pat. No. 9,427,600, which is a continuation of application No. 14/169,709, filed on Jan. 31, 2014, now Pat. No. 9,039,619, which is a continuation of application No. 13/230,498, filed on Sep. 12, 2011, now Pat. No. 8,641,622, which is a continuation of application No. 11/163,150, filed on Oct. 6, 2005, now Pat. No. 8,066,641.

(60) Provisional application No. 60/617,295, filed on Oct. 7, 2004.

**Publication Classification**

(51) **Int. Cl.**

*A61N 7/02* (2006.01)

*A61B 5/00* (2006.01)

*A61B 8/08* (2006.01)

(57)

**ABSTRACT**

A probe for ultrasound treatment of skin laxity are provided. Systems and methods can include ultrasound imaging of the region of interest for localization of the treatment area, delivering ultrasound energy at a depth and pattern to achieve the desired therapeutic effects, and/or monitoring the treatment area to assess the results and/or provide feedback. In an embodiment, a treatment system and method can be configured for producing arrays of sub-millimeter and larger zones of thermal ablation to treat the epidermal, superficial dermal, mid-dermal or deep dermal components of tissue.

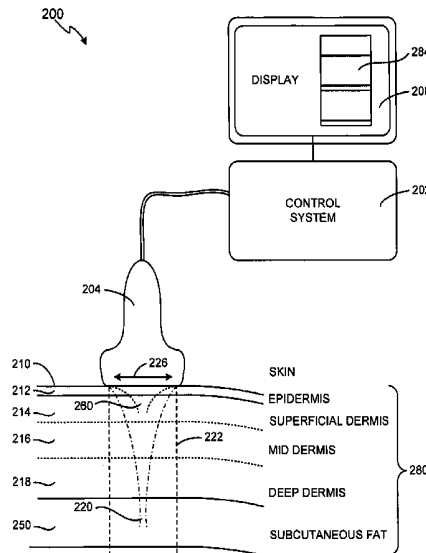

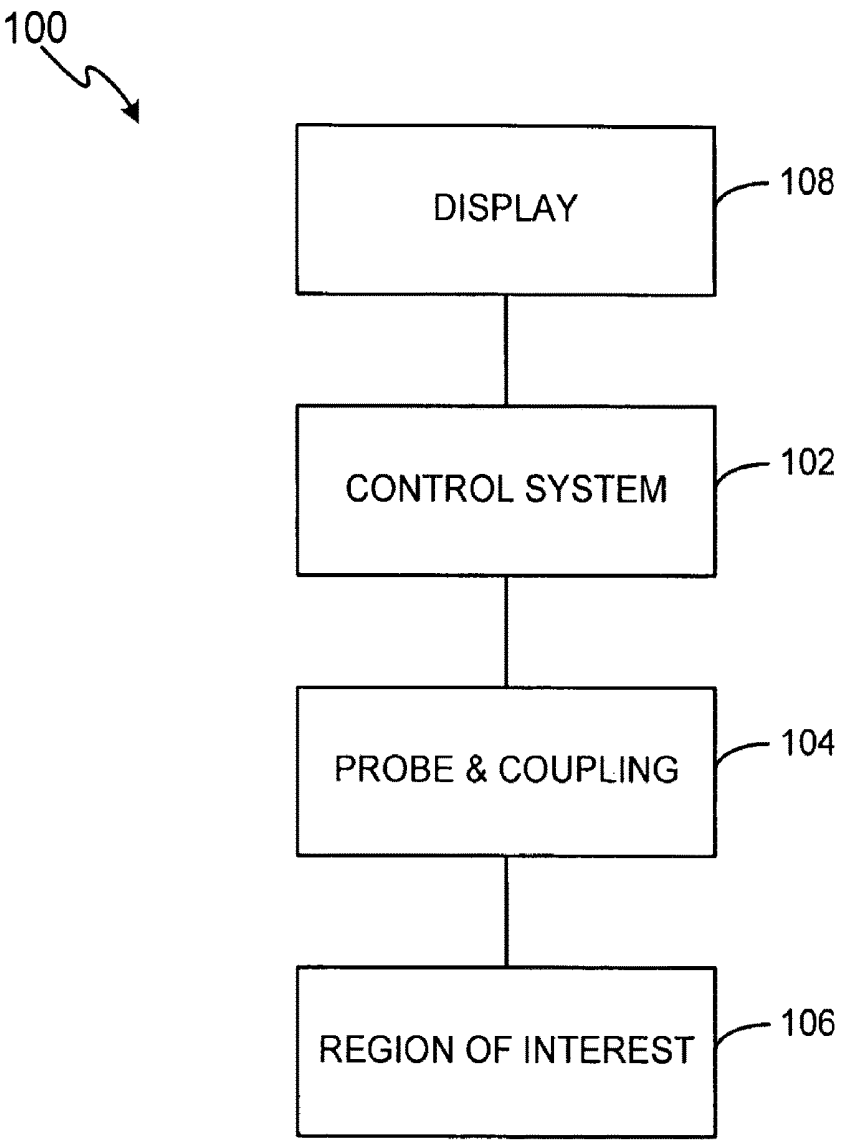

**FIG. 1**

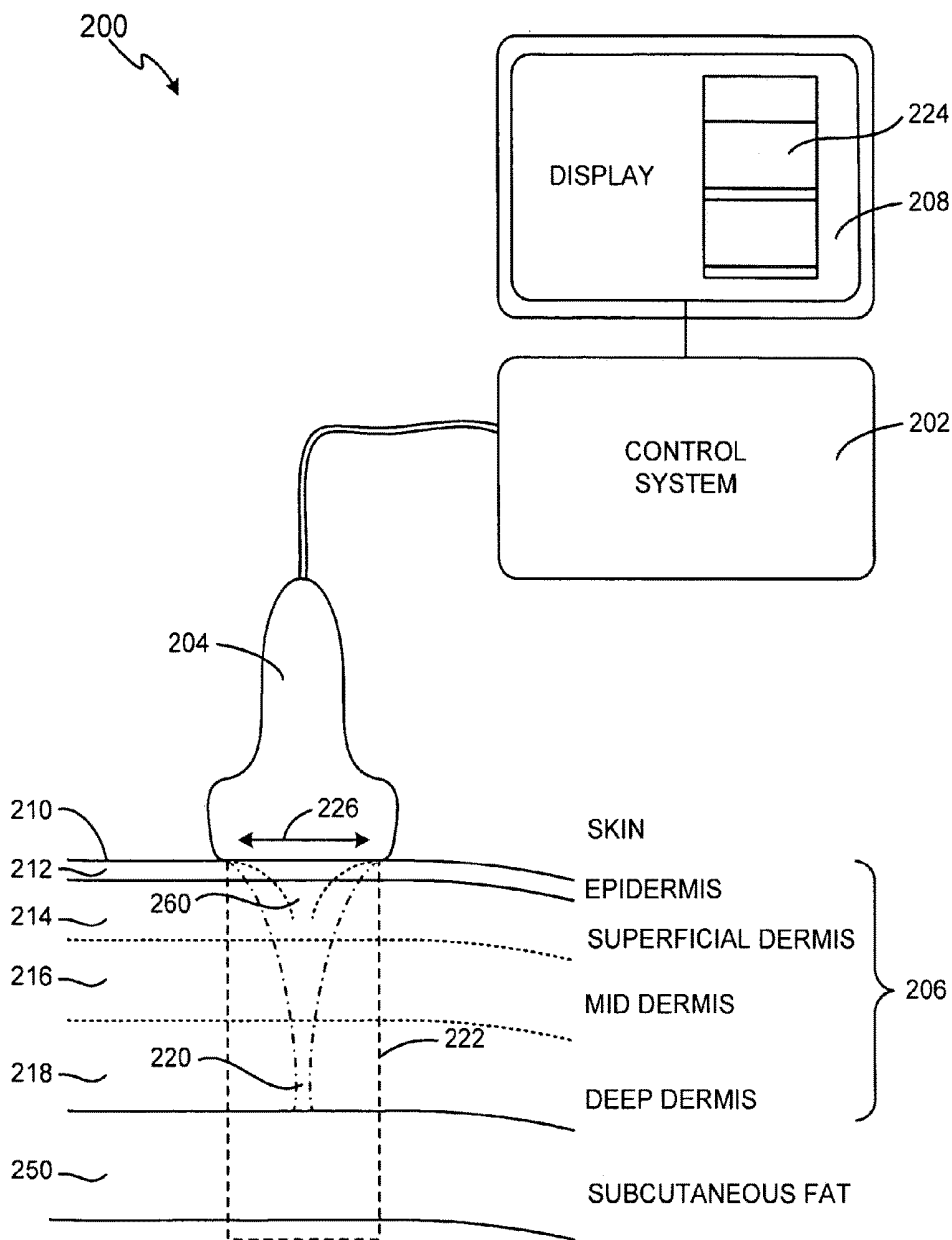

FIG. 2A

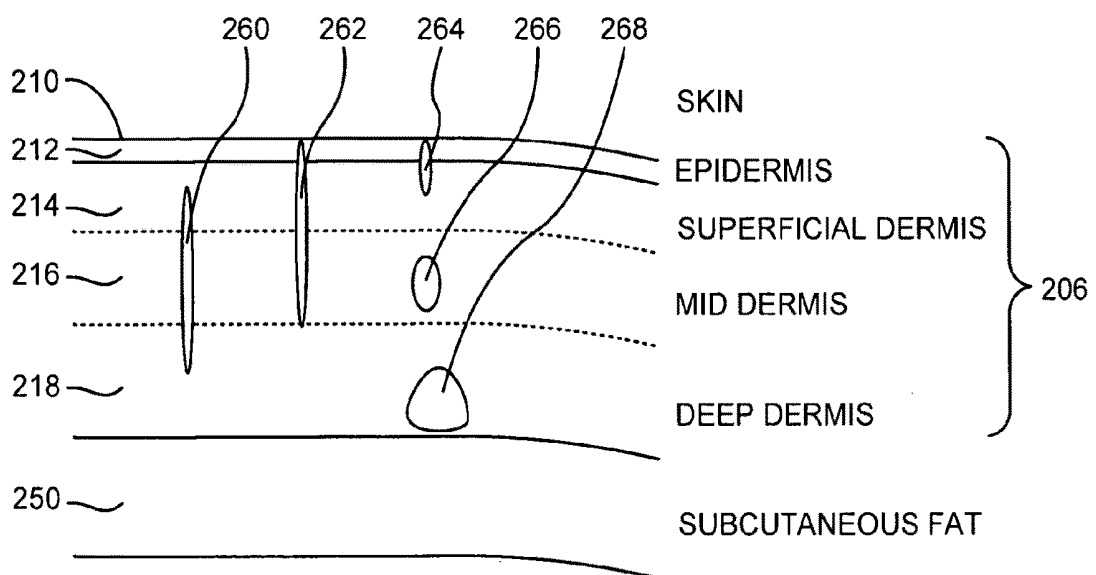

FIG. 2B

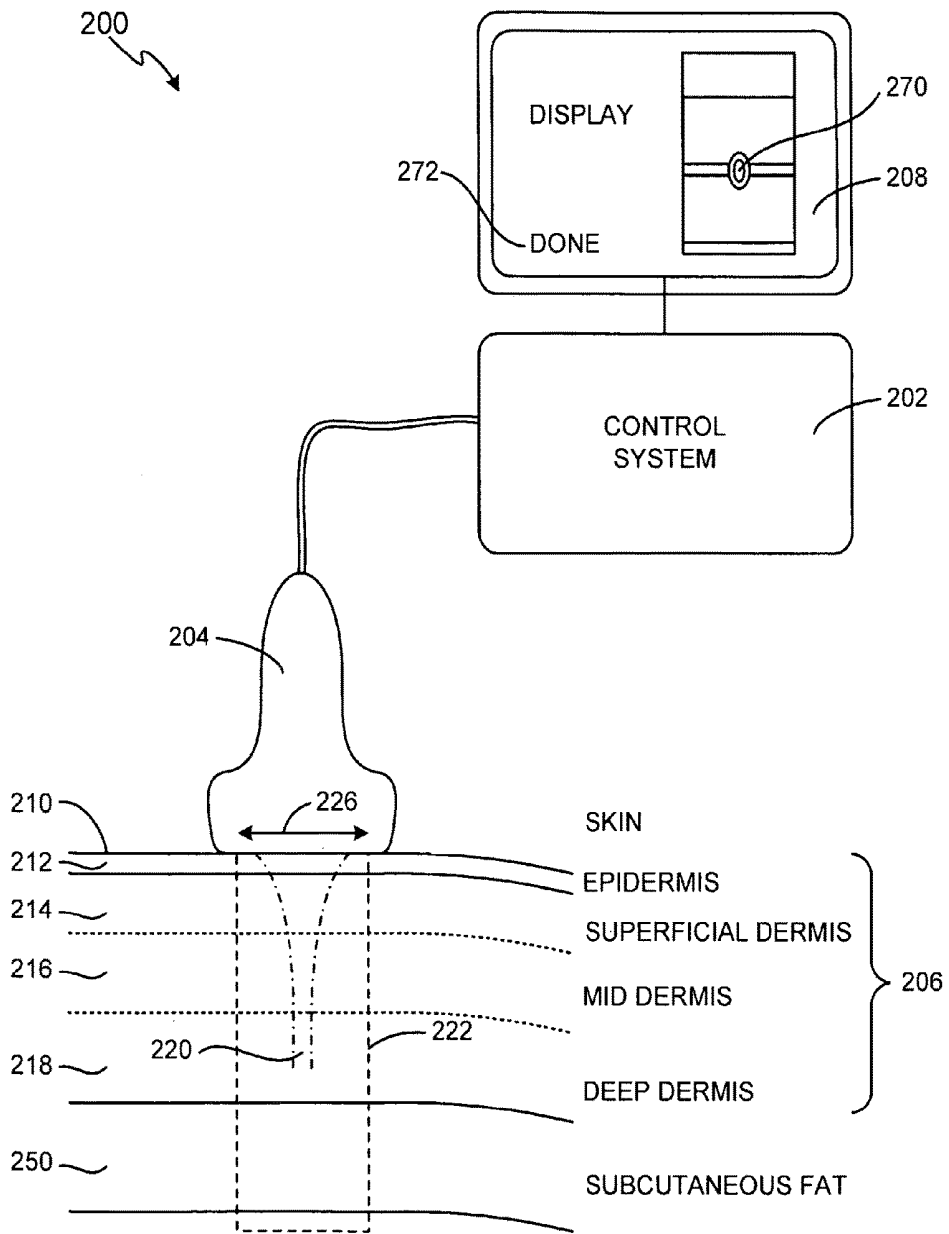

FIG. 2C

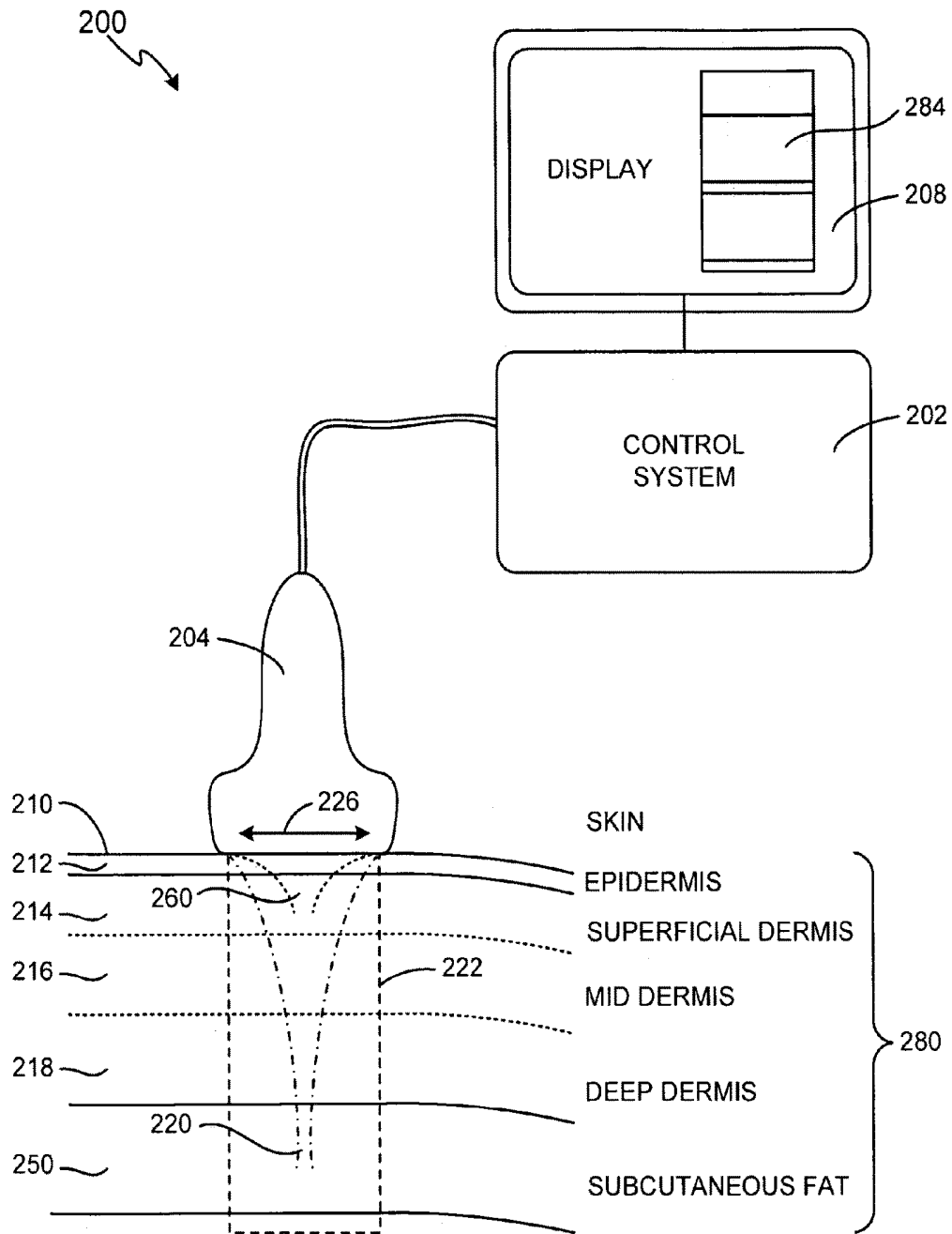

FIG. 2D

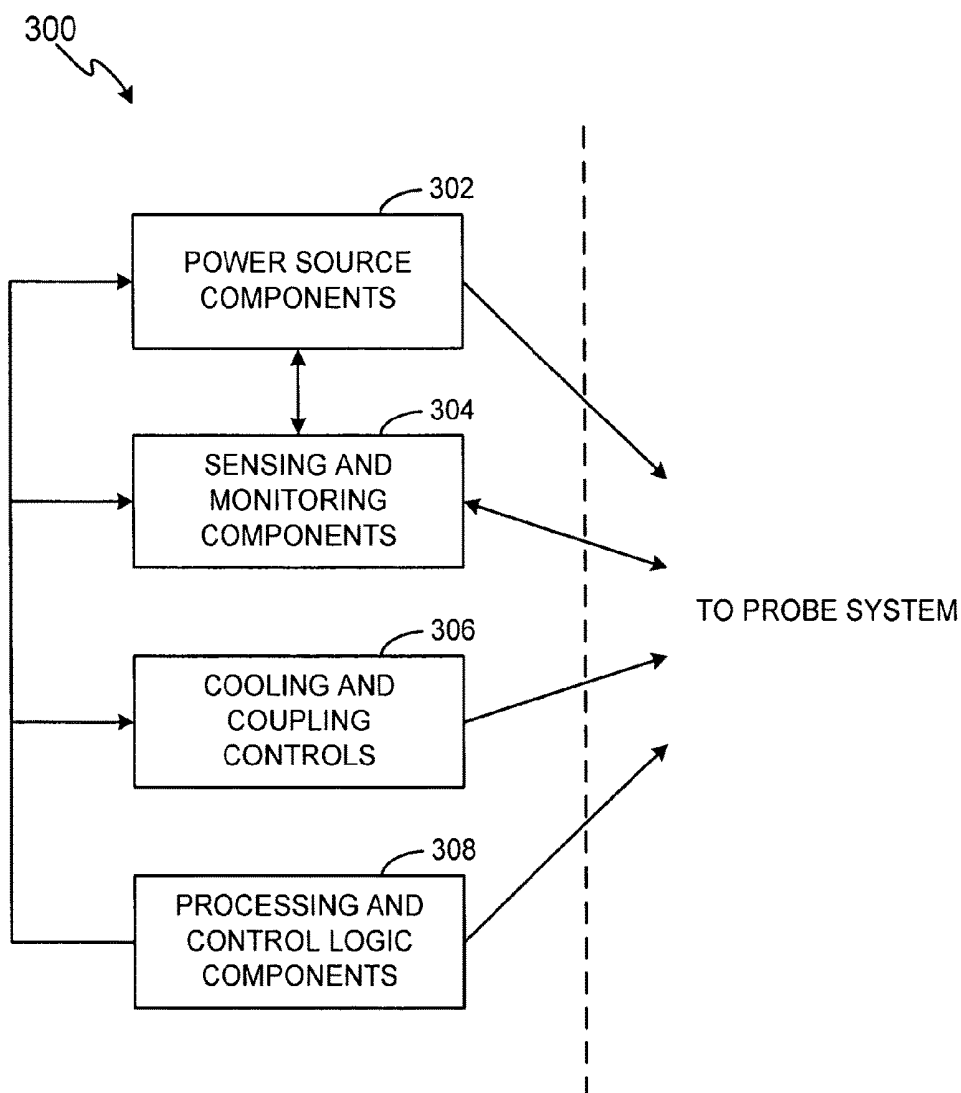
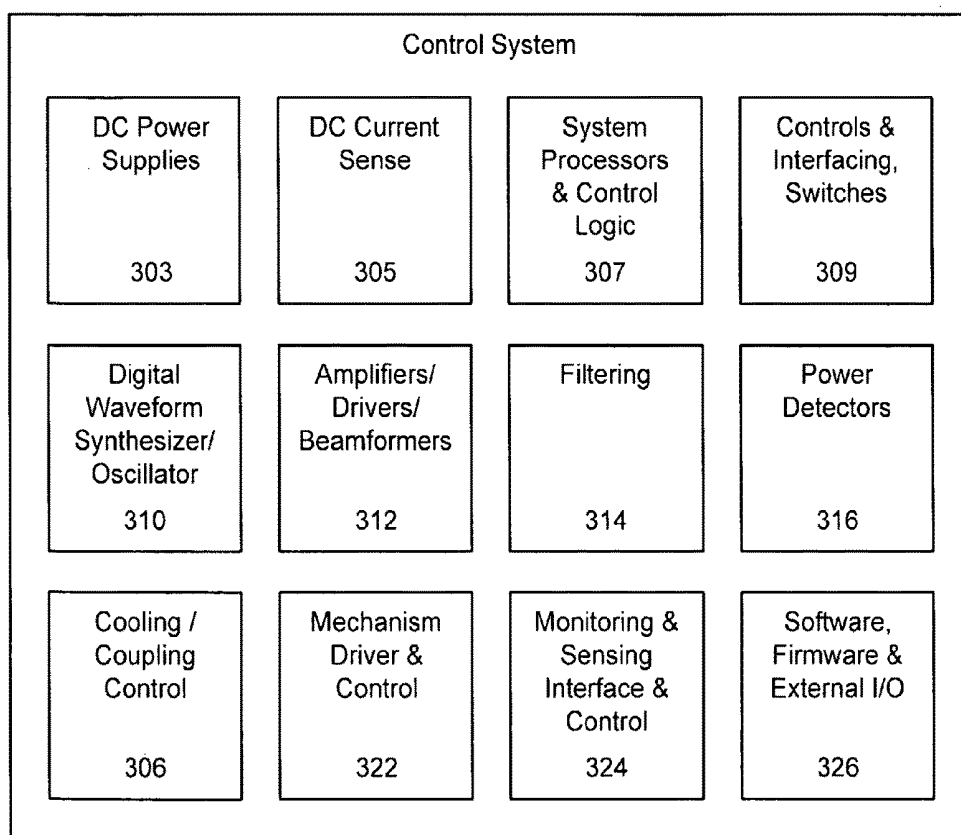

FIG. 3A

300 ↘



**FIG. 3B**

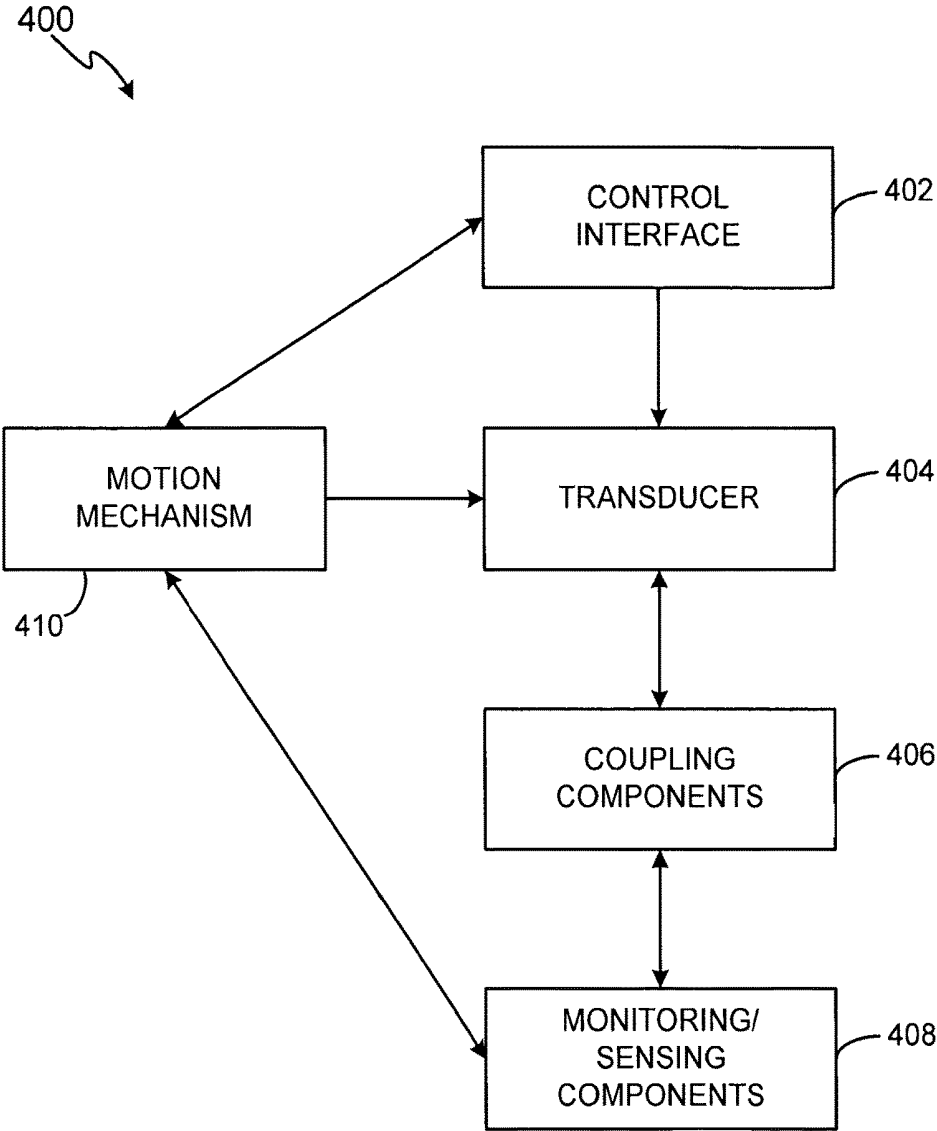
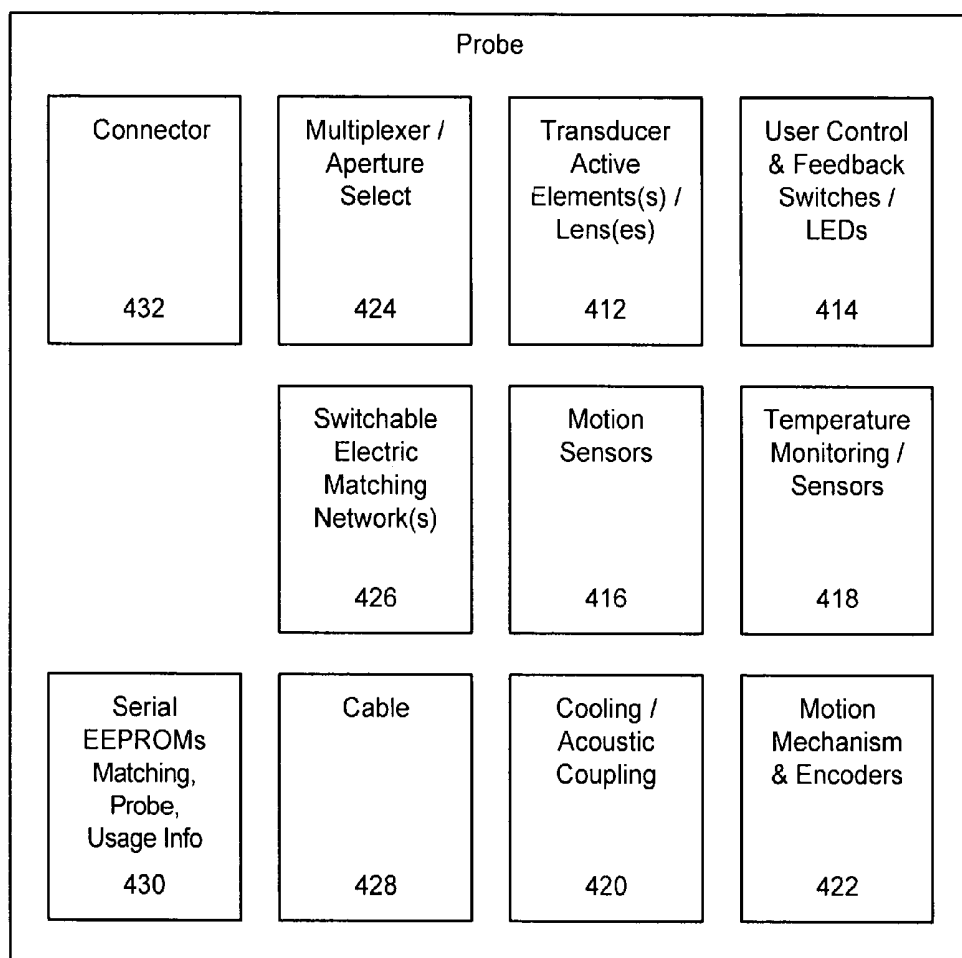

FIG. 4A

400 ↘



**FIG. 4B**

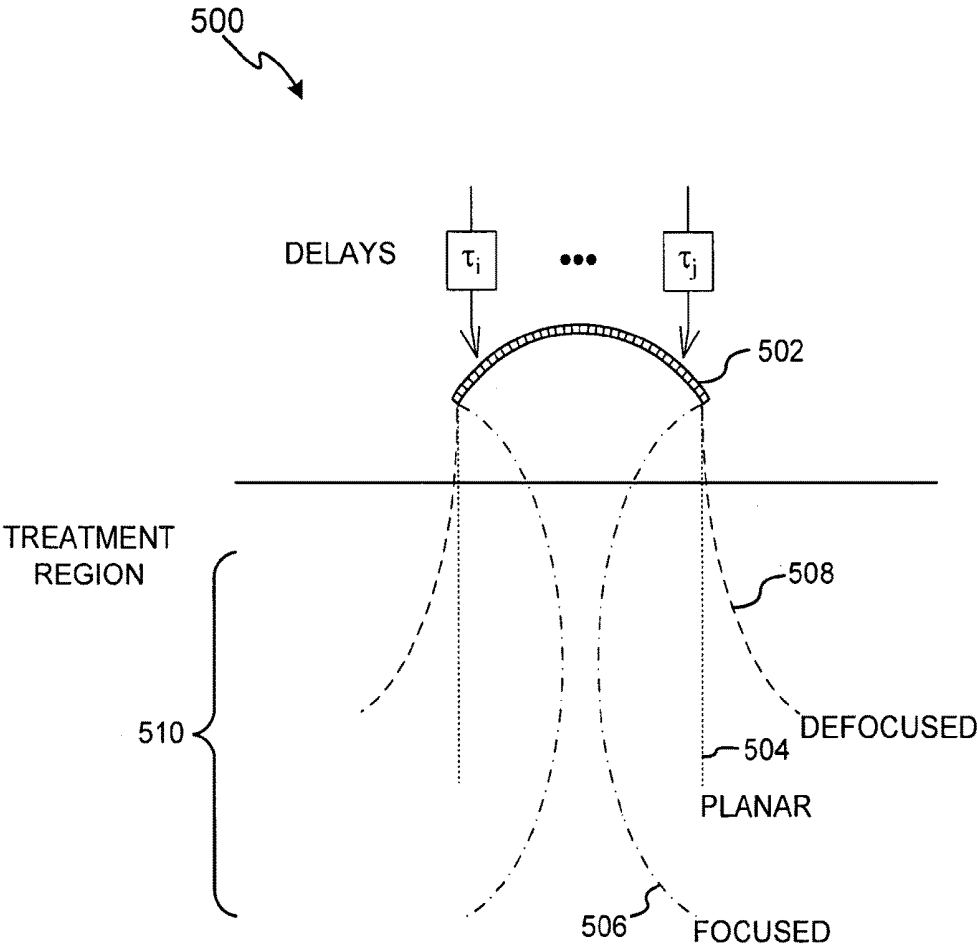
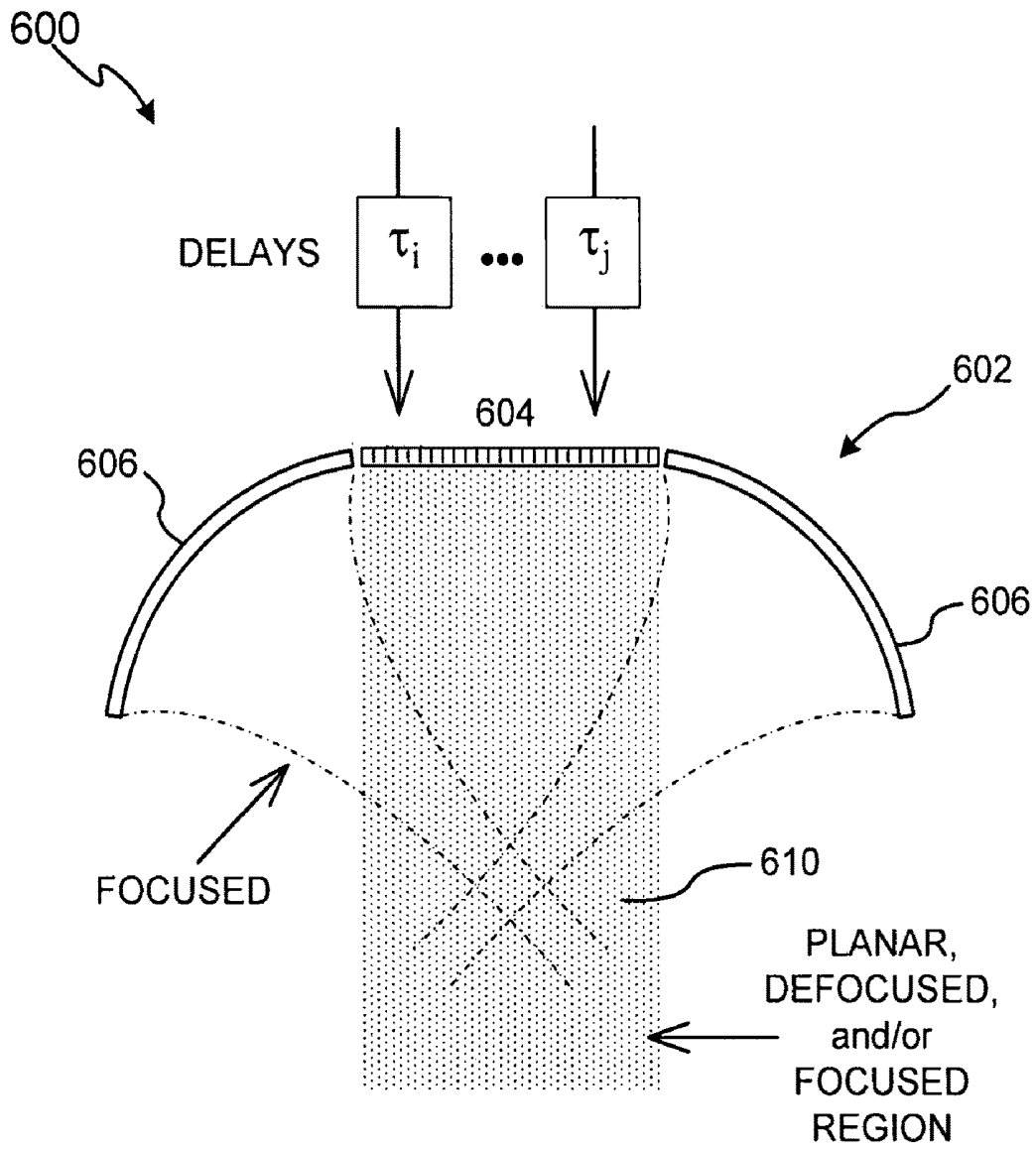
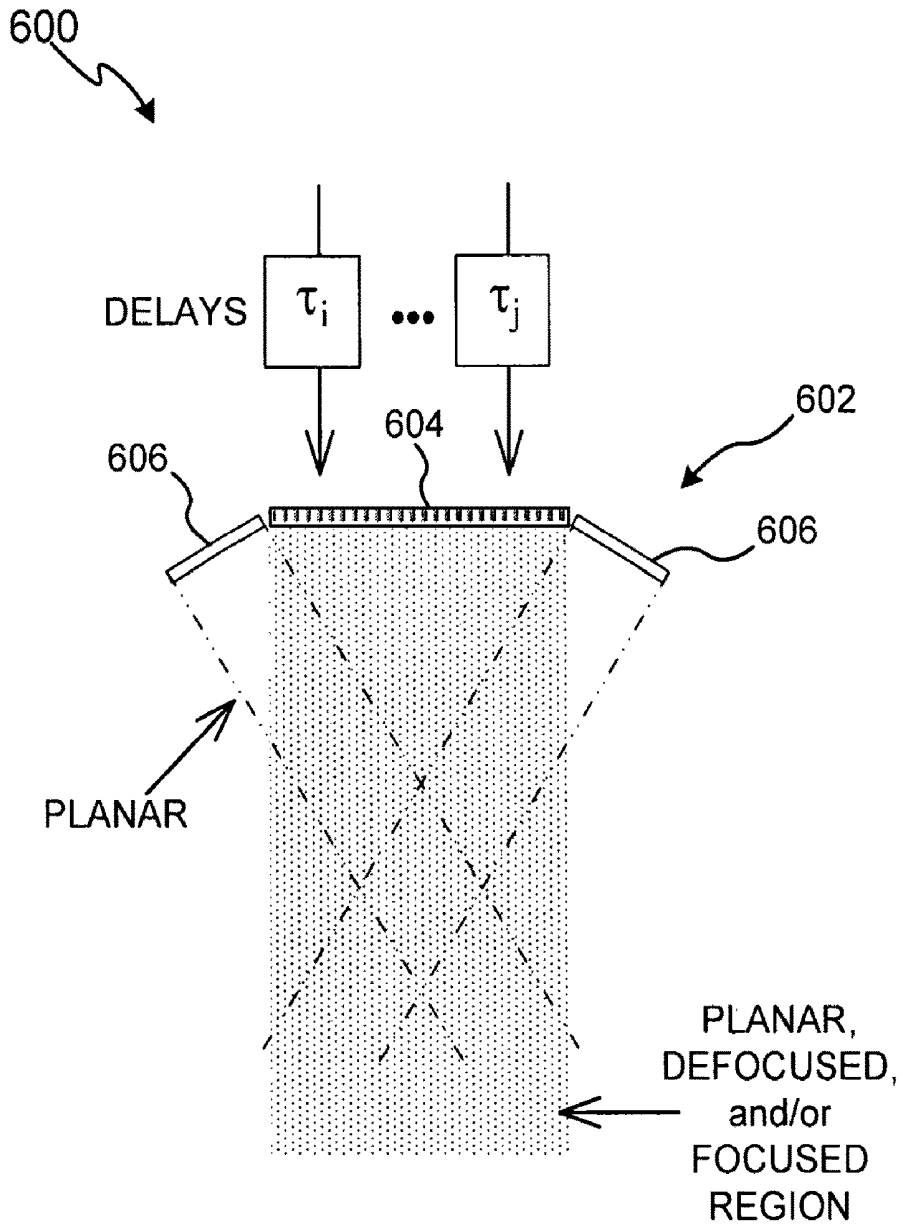

FIG. 5



**FIG. 6A**



**FIG. 6B**

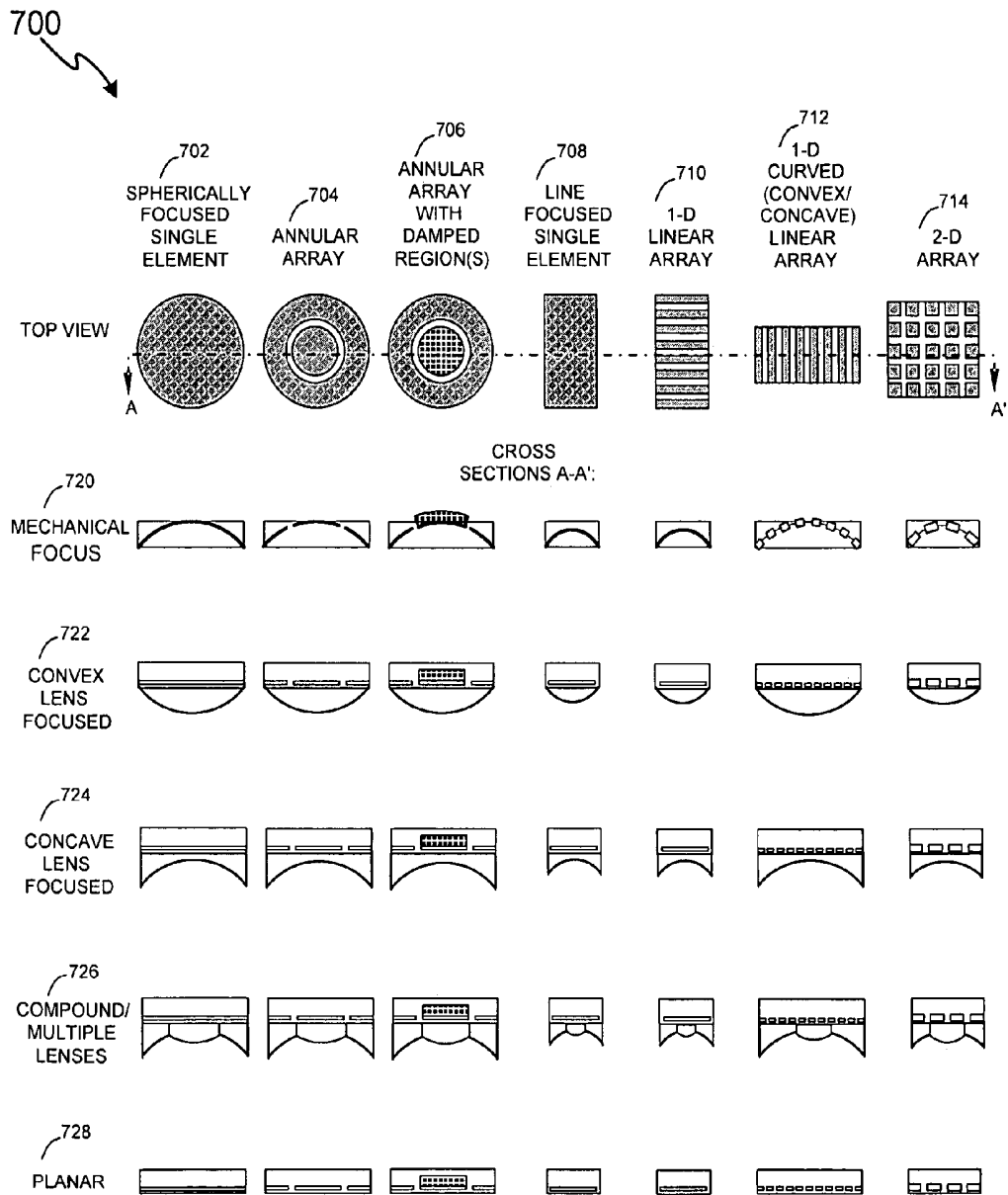

FIG. 7

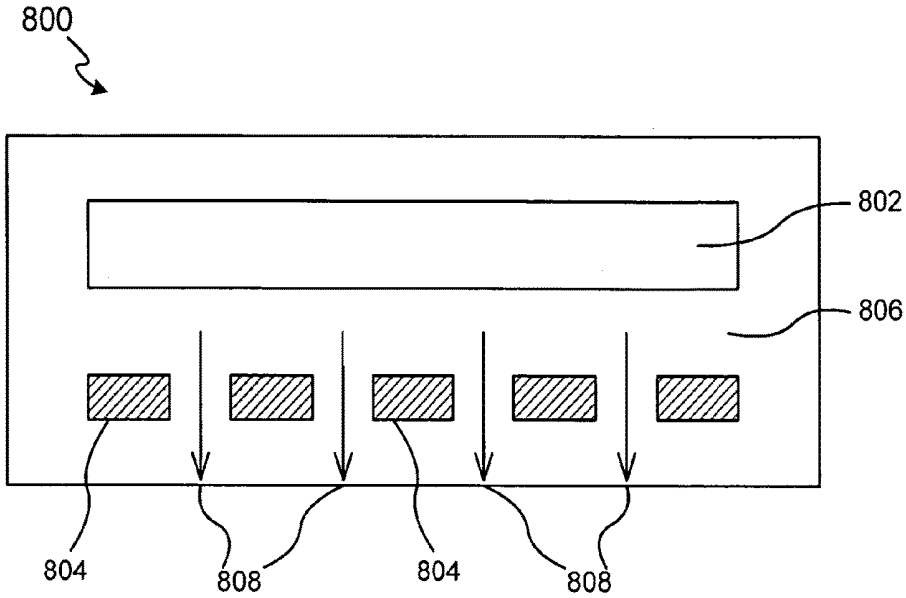

FIG. 8A

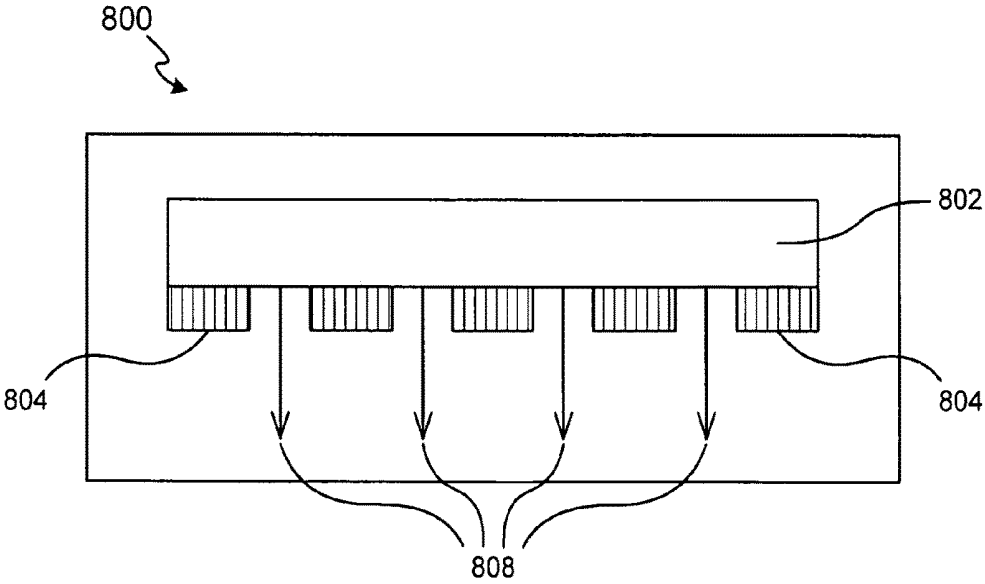

FIG. 8B

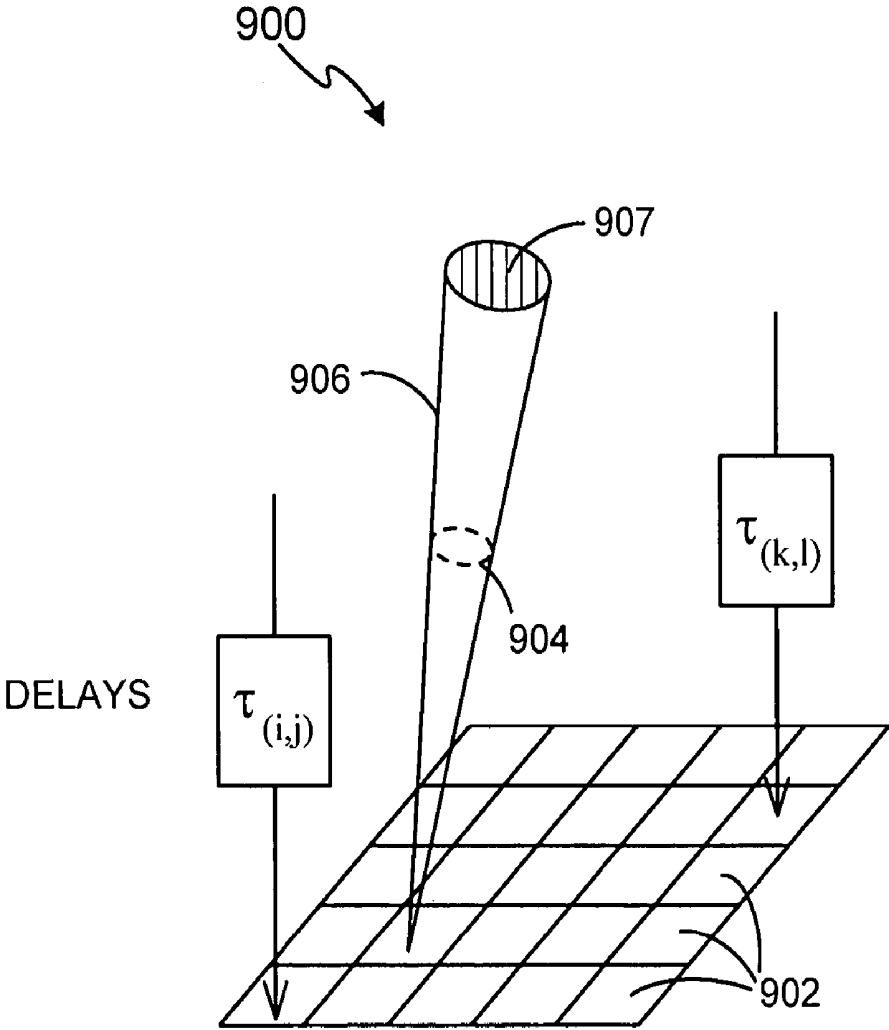

FIG. 9

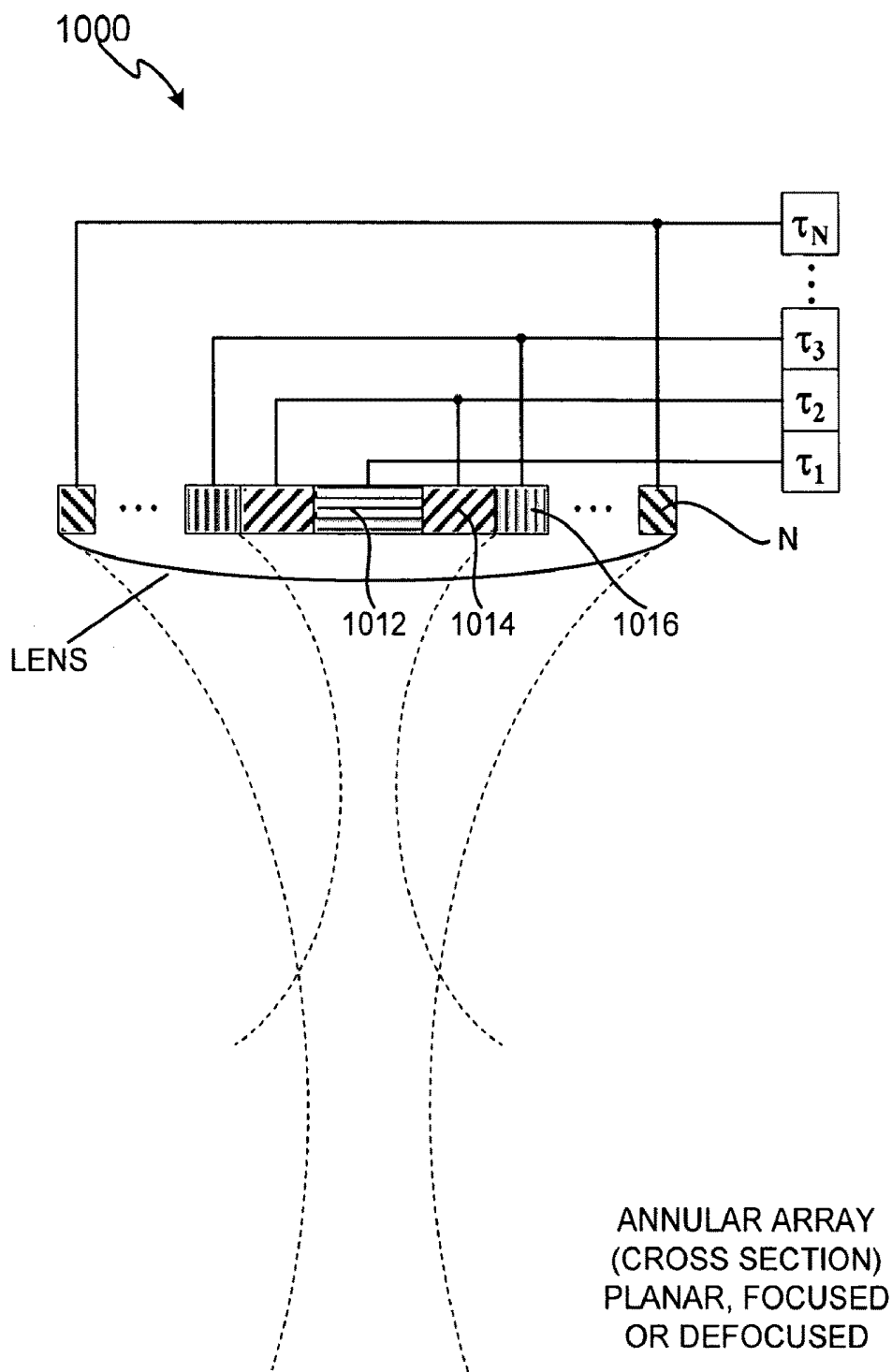
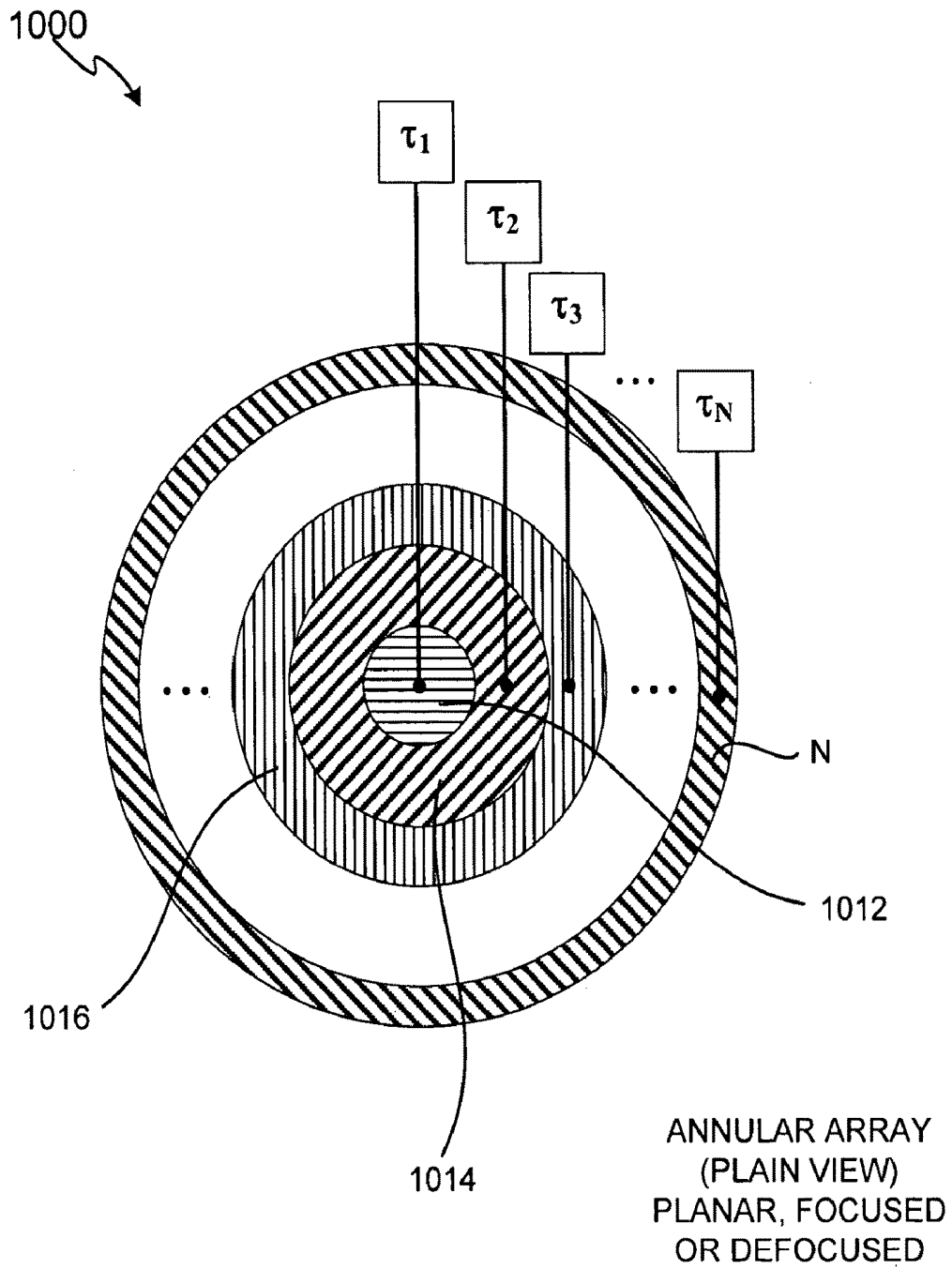

FIG. 10A



**FIG. 10B**

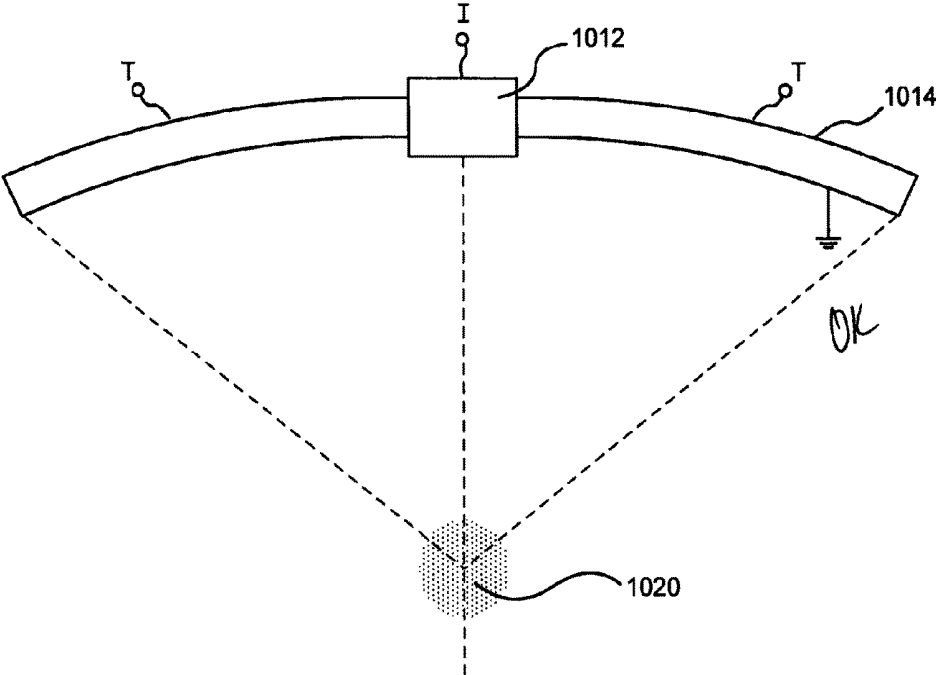

FIG. 10C

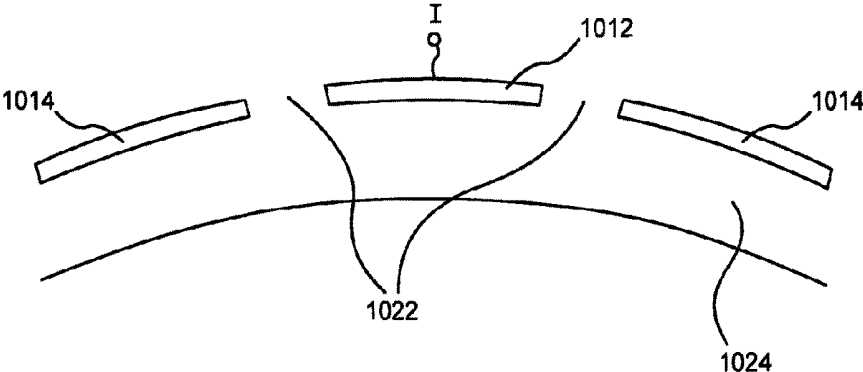

FIG. 10D

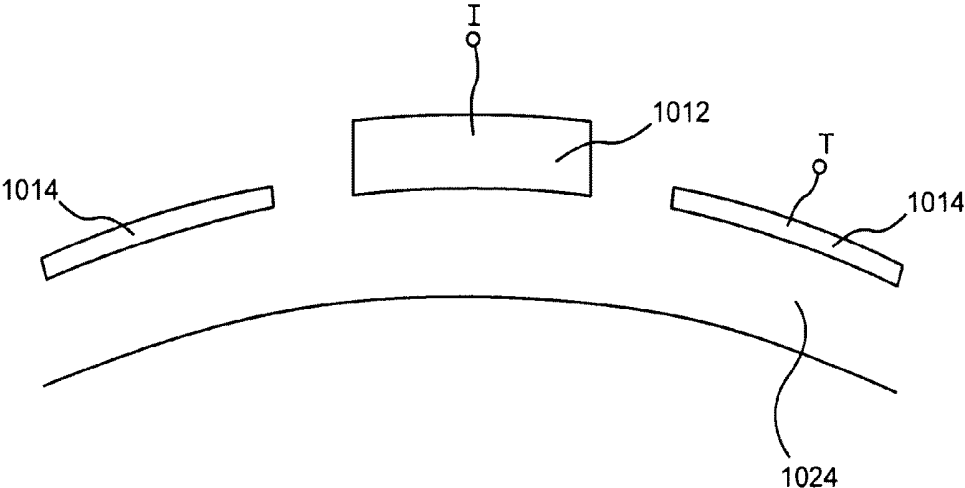

FIG. 10E

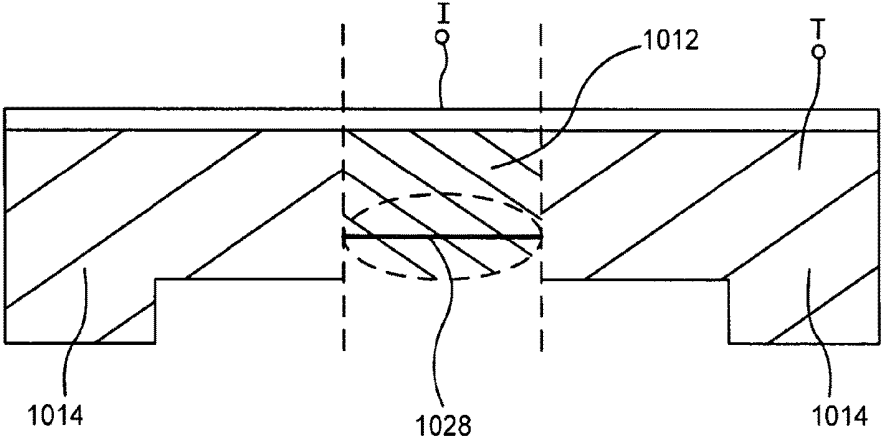

FIG. 10F

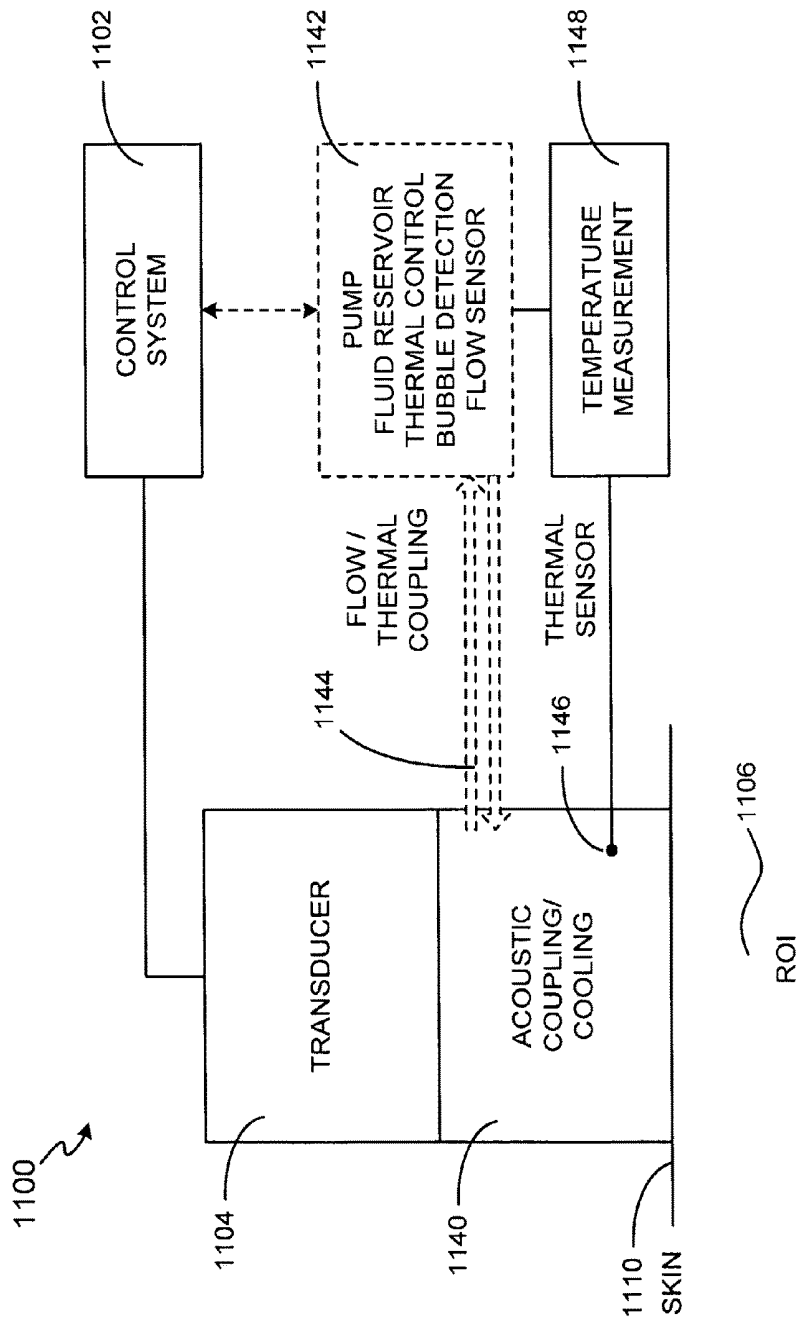

FIG. 11

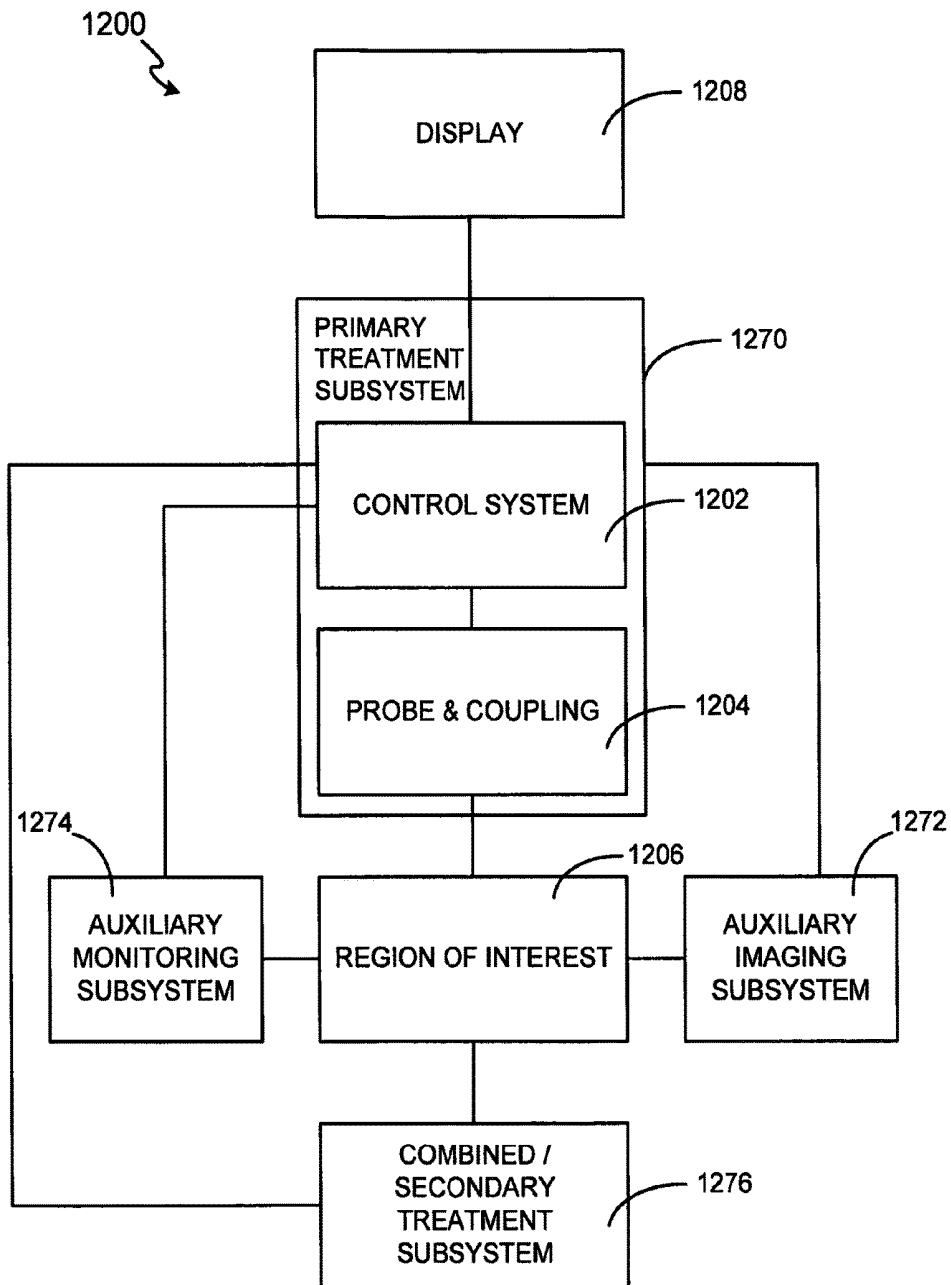
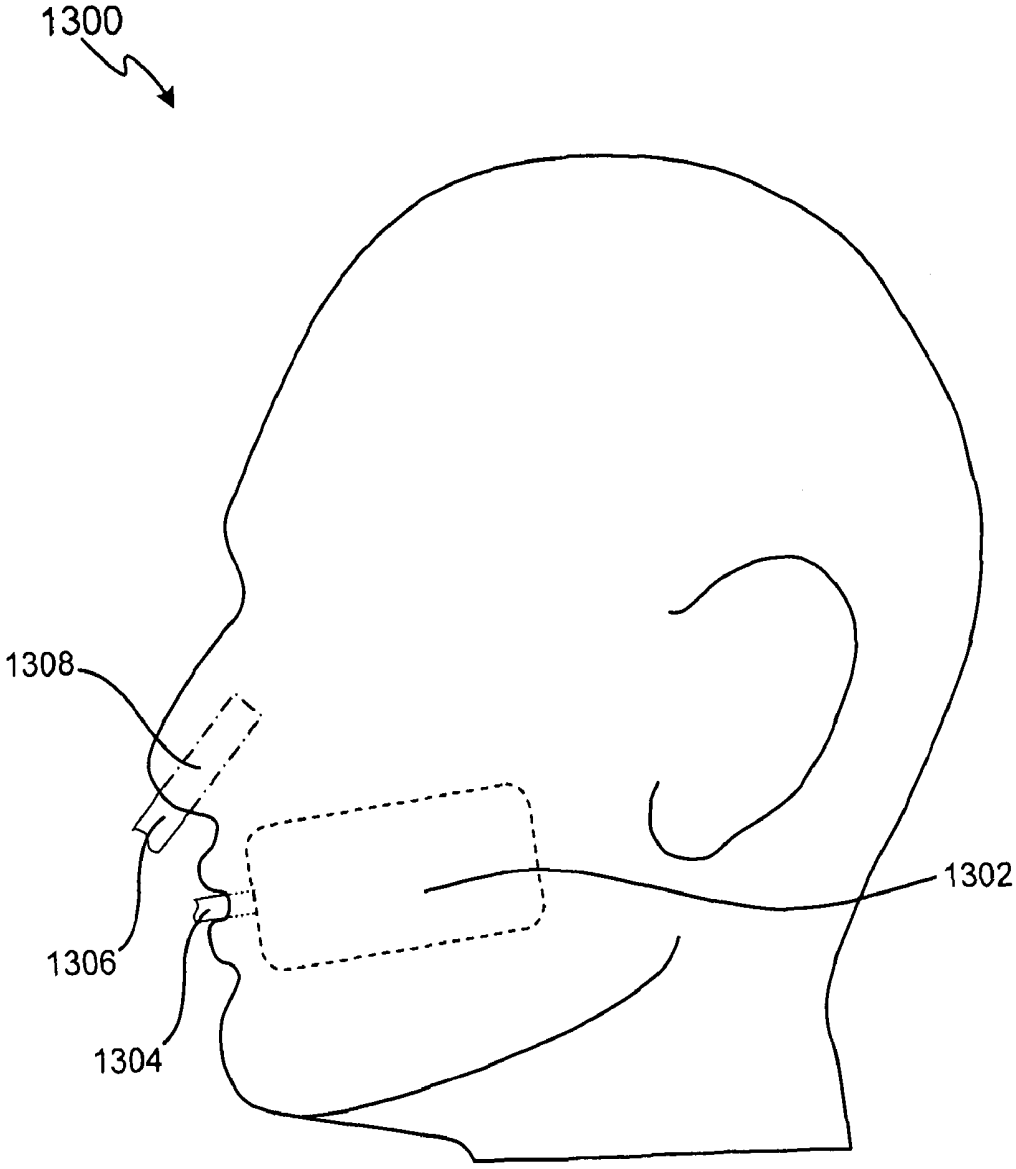

FIG. 12



**FIG. 13**

## ULTRASOUND PROBE FOR TREATING SKIN LAXITY

### INCORPORATION BY REFERENCE TO ANY PRIORITY APPLICATIONS

[0001] This application is a continuation of U.S. patent application Ser. No. 15/996,255, filed Jun. 1, 2018, which is a continuation of U.S. patent application Ser. No. 15/821,070 issued as U.S. Pat. No. 10,010,724, which is a continuation of U.S. patent application Ser. No. 15/625,700, issued as U.S. Pat. No. 9,827,449, which is a continuation of U.S. patent application Ser. No. 15/248,407, issued as U.S. Pat. No. 9,694,211, which is a continuation of U.S. patent application Ser. No. 14/692,114, issued as U.S. Pat. No. 9,427,600, which is a continuation of U.S. patent application Ser. No. 14/169,709, issued as U.S. Pat. No. 9,039,619, which is a continuation of U.S. patent application Ser. No. 13/230,498, issued as U.S. Pat. No. 8,641,622, which is a continuation of U.S. patent application Ser. No. 11/163,150, issued as U.S. Pat. No. 8,066,641, which claims the benefit of priority to U.S. Provisional Application No. 60/617,295, each of which is incorporated in its entirety by reference herein. Any and all applications for which a foreign or domestic priority claim is identified in the Application Data Sheet as filed with the present application are hereby incorporated by reference under 37 CFR 1.57.

### BACKGROUND

[0002] The present invention relates to ultrasound therapy and imaging systems, and in particular to a method and system for treating photoaged tissue.

[0003] Photoaging of human skin is a complex response due to inflammation, oxidative injury, cellular and extracellular changes induced by decades of sunlight exposure. UV wavelengths are thought to be mainly responsible. Both of the primary skin layers, epidermis and dermis, are affected. Epidermal photoaging includes pigmentary lesions called ephelides (freckles) and solar lentiginos (larger pigmented spots), plus precancerous clonal lesions of keratinocytes called actinic keratoses. Thermal destruction of part or all of the epidermis, the outermost cellular layer of skin about 0.1 mm thick, is an effective treatment for epidermal photoaging. For example, lasers that vaporize epidermis are highly effective in a treatment called laser resurfacing. However laser resurfacing creates a significant skin wound with risk of infection, and prolonged healing. Dermal changes of photoaging include solar elastosis (an accumulation of abnormally-formed elastin fibers in the upper reticular layer of the dermis), laxity, loss of elasticity, fine and coarse wrinkles. Laser resurfacing to a depth below the dermoepidermal junction can be highly effective for improving dermal photoaging, through a process of stimulated wound healing. Deep chemical peels, dermabrasion and other methods of destruction of epidermis and/or dermis are also effective, and also produce a significant open skin wound with risk of infection and delayed healing.

[0004] Patterns of stimulated thermal damage to epidermis and/or dermis are also effective for treatment of photoaging. Recently, "fractional photothermolysis" using mid-infrared lasers to produce a microscopic array of thermal injury zones that include both epidermis and dermis was reported to be effective and well-tolerated for treatment of photoaging (D. Manstein et al. "Fractional Photothermolysis: a new

concept for cutaneous remodeling using microscopic patterns of thermal injury." *Lasers Surg Med* 34:426-438, 2004). A primary advantage of fractional photothermolysis is that each zone of thermal injury is smaller than can be easily seen with the unaided eye, and surrounded by a zone of healthy tissue that initiates a rapid healing response. As described Manstein, the epidermis is stimulated to heal rapidly and without creating an open wound. The microscopic zones of thermally injured epidermis slough harmlessly from the skin surface after several days to several weeks, leaving a rejuvenated epidermis with less photoaging changes. Repeat treatments, which are well tolerated, can be performed until a desired result is obtained. The microscopic zones of thermal injury with fractional photothermolysis extend well into the dermis, as well. Dermis does not heal as rapidly as epidermis, in general. Over weeks to months following treatment, some of the abnormal dermis due to photoaging is remodeled, however, leading to improvement in laxity, wrinkles and skin texture.

[0005] Fractional photothermolysis (FP) is intrinsically limited to regions of approximately the upper 1-millimeter of skin. The basic concept of producing well-controlled arrays of thermal injury is therefore limited with fractional photothermolysis, to superficial aspects of photoaging. Aging, which also causes laxity of the skin, and photoaging involve deeper layers of the dermis. Solar elastosis can extend throughout the dermis, to approximately 3 mm deep or more. Laxity and loss of elasticity due to aging are bulk problems of the dermis.

[0006] A fundamental requirement for producing arrays of small thermal injury zones using a source of radiant energy that propagates and is absorbed within tissue, is that the source of radiant energy be capable of being adequately delivered to the tissue depth for which the array is desired. Near the skin surface, light can be used, as in fractional photothermolysis. However, light that propagates more than about 1 mm through skin has been multiplied scattered, and can no longer be focused or delivered.

### SUMMARY

[0007] A method and system for ultrasound treatment of photoaged tissue are provided. An exemplary method and system are configured for first, ultrasound imaging of the region of interest for localization of the treatment area, second, delivery of ultrasound energy at a depth and pattern to achieve the desired therapeutic effects, and third to monitor the treatment area during and after therapy to assess the results and/or provide feedback. The exemplary treatment method and system can be configured for producing arrays of sub-millimeter and larger zones of thermal ablation to treat the epidermal, superficial dermal, mid-dermal and deep dermal components of photoaged tissue.

[0008] In accordance with an exemplary embodiment, the treatment method and system use focused, unfocused, and/or defocused ultrasound for treatment of epidermal, superficial dermal, dermal, mid-dermal, and/or deep dermal components of photoaged tissue by adjusting the strength, depth, and/or type of focusing, energy levels and timing cadence. For example, focused ultrasound can be used to create precise arrays of microscopic thermal damage much deeper into the skin or even into subcutaneous structures. Detection of changes in the reflection of ultrasound can be used for feedback control to detect a desired effect on the tissue and used to control the exposure intensity, time, and/or position.

[0009] In accordance with an exemplary embodiment, an exemplary treatment system comprises an imaging/therapy probe, a control system and display system. The imaging/therapy probe can comprise various probe and/or transducer configurations. For example, the probe can be configured for a combined dual-mode imaging/therapy transducer, coupled or co-housed imaging/therapy transducers, a separate therapy probe and imaging probe, or a single therapy probe. The control system and display system can also comprise various configurations for controlling probe and system functionality, including for example a microprocessor with software and a plurality of input/output and communication devices, a system for controlling electronic and/or mechanical scanning and/or multiplexing of transducers, a system for power delivery, systems for monitoring, systems for sensing the spatial position of the probe and/or temporal parameters of the transducers, and systems for handling user input and recording treatment input and results, among others.

#### BRIEF DESCRIPTION OF THE DRAWINGS

[0010] The subject matter of the invention is particularly pointed out in the concluding portion of the specification. The invention, however, both as to organization and method of operation, may best be understood by reference to the following description taken in conjunction with the accompanying drawing figures, in which like parts may be referred to by like numerals:

[0011] FIG. 1 illustrates a block diagram of a treatment system in accordance with an exemplary embodiment of the present invention;

[0012] FIGS. 2A-2D illustrates a schematic diagram of an ultrasound treatment system including therapy, imaging and/or monitoring and treating photoaged tissue in accordance with various exemplary embodiments of the present invention;

[0013] FIGS. 3A and 3B illustrate block diagrams of an exemplary control system in accordance with exemplary embodiments of the present invention;

[0014] FIGS. 4A and 4B illustrate block diagrams of an exemplary probe system in accordance with exemplary embodiments of the present invention;

[0015] FIG. 5 illustrates a cross-sectional diagram of an exemplary transducer in accordance with an exemplary embodiment of the present invention;

[0016] FIGS. 6A and 6B illustrate cross-sectional diagrams of an exemplary transducer in accordance with exemplary embodiments of the present invention;

[0017] FIG. 7 illustrates exemplary transducer configurations for ultrasound treatment in accordance with various exemplary embodiments of the present invention;

[0018] FIGS. 8A and 8B illustrate cross-sectional diagrams of an exemplary transducer in accordance with another exemplary embodiment of the present invention;

[0019] FIG. 9 illustrates an exemplary transducer configured as a two-dimensional, array for ultrasound treatment in accordance with an exemplary embodiment of the present invention;

[0020] FIGS. 10A-10F illustrate cross-sectional diagrams of exemplary transducers in accordance with other exemplary embodiments of the present invention;

[0021] FIG. 11 illustrates a schematic diagram of an acoustic coupling and cooling system in accordance with an exemplary embodiment of the present invention;

[0022] FIG. 12 illustrates a block diagram of an ultrasound treatment system combined with additional subsystems and methods of treatment monitoring and/or treatment imaging as well as a secondary treatment subsystem in accordance with an exemplary embodiment of the present invention; and

[0023] FIG. 13 illustrates a schematic diagram with imaging, therapy, or monitoring being provided with one or more active or passive oral inserts in accordance with an exemplary embodiment of the present invention.

#### DETAILED DESCRIPTION

[0024] The present invention may be described herein in terms of various functional components and processing steps. It should be appreciated that such components and steps may be realized by any number of hardware components configured to perform the specified functions. For example, the present invention may employ various medical treatment devices, visual imaging and display devices, input terminals and the like, which may carry out a variety of functions under the control of one or more control systems or other control devices. In addition, the present invention may be practiced in any number of medical contexts and that the exemplary embodiments relating to a method and system for treating photoaged tissue as described herein are merely indicative of exemplary applications for the invention. For example, the principles, features and methods discussed may be applied to any medical application. Further, various aspects of the present invention may be suitably applied to other applications.

[0025] In accordance with various aspects of the present invention, a method and system for treating photoaged tissue are provided. For example, in accordance with an exemplary embodiment, with reference to FIG. 1, an exemplary treatment system 100 configured to treat a region of interest (ROI) 106 comprises a control system 102, an imaging/therapy probe with acoustic coupling 104, and a display system 108. Control system 102 and display 108 can comprise various configurations for controlling functionality of probe 104 and system 100, including for example a microprocessor with software and a plurality of input/output and communication devices, a system for controlling electronic and/or mechanical scanning and/or multiplexing of transducers, a system for power delivery, systems for monitoring, systems for sensing the spatial position of the probe and/or temporal parameters of the transducers, and/or systems for handling user input and recording treatment input and results, among others. Imaging/therapy probe 104 can comprise various probe and/or transducer configurations. For example, probe 104 can be configured for a combined dual-mode imaging/therapy transducer, coupled or co-housed imaging/therapy transducers, a separate therapy probe and separate imaging probe, or a single therapy probe. In accordance with exemplary embodiments, imaging transducers may operate at frequencies from approximately 2 to 75 MHz or more, while therapy energy can be delivered at frequencies from approximately 2 to 50 MHz, with 2 MHz to 25 MHz being typical.

[0026] For the treatment of photoaged tissue, it is desirable to be able to produce well controlled arrays of microscopic zones of thermal injury not only near the surface of skin, but in the mid-dermis, and/or in the deep dermis. Thermal ablation of dermis at temperatures greater than about 60° C., capable of producing denaturation of tissue, is

also desirable in such arrays of thermal lesions. Shrinkage of dermis due to thermal action results from tightening of the skin.

**[0027]** In contrast to optical or RF approaches, ultrasound energy propagates as a wave with relatively little scattering, over depths up to many centimeters in tissue depending on the ultrasound frequency. The focal spot size achievable with any propagating wave energy, depends on wavelength. Ultrasound wavelength is equal to the acoustic velocity divided by the ultrasound frequency. Attenuation (absorption, mainly) of ultrasound by tissue also depends on frequency.

**[0028]** In accordance with an exemplary embodiment, the use of focused, unfocused, or defocused ultrasound for treatment of epidermal, superficial dermal, dermal, mid-dermal, and deep dermal components of photoaged tissue through adjustment of the strength, depth, and type of focusing, energy levels and timing cadence. For example, focused ultrasound can be used to create precise arrays of microscopic thermal ablation zones which have several advantages over fractional photothermolysis (FP). At high frequency and with superficial focusing or diffraction pattern, ultrasound ablation can mimic FP but utilize a simpler ablation device. Unlike fractional photothermolysis, ultrasound can produce an array of ablation zones much deeper into the skin or even into subcutaneous structures. Detection of changes in the reflection of ultrasound can be used for feedback control to detect a desired effect on the tissue and used to control the exposure intensity, time, and/or position.

**[0029]** To further illustrate the use of ultrasound for the treatment of photoaged tissue, with reference to FIG. 2A, an exemplary method and system are configured for initially imaging a region 222 of a region of interest 206 and displaying that region 224 during the localization of the treatment area and surrounding structures. After localization, delivery of ultrasound energy 220 at a depth, distribution, timing, and energy level to achieve the desired therapeutic effect of thermal ablation to treat an epidermis layer 212, superficial dermis layer 214, mid-dermis layer 216, and/or deep dermis layer 218 can be provided. Before, during, and after therapy, i.e., before, during, and after the delivery of ultrasound energy 220, exemplary method and system 200 can suitably monitor the treatment area and surrounding structures to plan and assess the results and/or provide feedback to control system 202 and/or a system user.

**[0030]** While an imaging function may be configured within control system 202 to facilitate imaging a region of interest, in accordance with another exemplary embodiment, an exemplary treatment system 200 may also be configured for therapy only or therapy and monitoring, without imaging functions. In such a case prior known depth of the region of interest, approximately 0 to 5 mm or less, is employed to achieve treatment zones in photoaged skin.

**[0031]** Probe 204 and/or transducers within can be mechanically and/or electronically scanned in a direction 226 to place treatment zones 260 over an extended area, such as a line to generate a matrix of closely spaced treatment spots. Treatment depth 220 can be adjusted between a range of approximately 0 to 5 mm, or otherwise until the depth of the deep dermis. Treatment may be confined to a fixed depth or a few discrete depths, or can be adjustment limited to a fine range, e.g. from approximately between 0 to 5 mm or the greatest depth of the deep dermis,

or can be dynamically adjusted during treatment, to the treat region of interest 206 that lies above subcutaneous fat region 250.

**[0032]** In accordance with another exemplary embodiment of the present invention, with reference to FIG. 2B, a treated zone 260 may extend throughout regions of the dermis, and may even extend to the epidermis, 262. In addition, as a treated zone increases in depth its cross section may increase from small size 264 (sub millimeter) in a shallow region near or at the epidermis, to medium size 266 (sub millimeter to millimeter sized) in a middle zone near or at the mid dermis, to large size 268 (millimeter sized) in deep zones near or at the deep dermis. Furthermore a single treated zone can have a shape expanding in cross section with depth, and/or be composed of the fusion of several smaller treatment zones. Spacing of treatment zones can be on the order of the treatment zone size. The ultrasound beam can be spatially and/or temporally controlled by changing the position of the transducer, its frequency, treatment depth, drive amplitude, and timing via the control system. For example, the ultrasound beam can be controlled as set forth in U.S. patent application Ser. No. 11/163,148, filed Oct. 6, 2005, and entitled METHOD AND SYSTEM FOR CONTROLLED THERMAL INJURY OF HUMAN SUPERFICIAL TISSUE, and hereby incorporated by reference.

**[0033]** In accordance with another exemplary embodiment of the present invention, with reference to FIG. 2C, an exemplary treatment method and system 200 may be configured to monitor the temperature profile or other tissue parameters of region of interest 206, such as attenuation or speed of sound of the treatment region and suitably adjust the spatial and/or temporal characteristics and energy levels of the ultrasound therapy transducer. The results of such monitoring techniques may be indicated on display 208, such as through display of one-, two-, or three-dimensional images of monitoring results 270, or may comprise an indicator 272, such as a success, fail and/or completed/done type of indication, or combinations thereof. Additional treatment monitoring methods may be based on one or more of temperature, video, profilometry, strain imaging and/or gauges or any other suitable sensing method.

**[0034]** In accordance with another exemplary embodiment, with reference to FIG. 2D, an expanded region of interest 280 can suitably include a combination of tissues, such as subcutaneous fat/adipose tissue 250. A combination of such tissues includes at least one of epidermis 212, superficial dermis 214, mid dermis 216, or deep dermis 218, in combination with at least one of muscle tissue, adipose tissue, or other tissues useful for treatment. For example, treatment 260 of superficial dermis may be performed in combination with treatment 220 of subcutaneous fat 250 by suitable adjustment of the spatial and temporal parameters of transducers in probe 204.

**[0035]** An exemplary control system 202 and display system 208 may be configured in various manners for controlling probe and system functionality for providing the various exemplary treatment methods illustrated above. For example, with reference to FIGS. 3A and 3B, in accordance with exemplary embodiments, an exemplary control system 300 can be configured for coordination and control of the entire therapeutic treatment process for producing arrays of sub-millimeter and larger zones of thermal ablation to treat the epidermal, superficial dermal, mid-dermal and deep dermal components of photoaged tissue. For example, con-

control system **300** can suitably comprise power source components **302**, sensing and monitoring components **304**, cooling and coupling controls **306**, and/or processing and control logic components **308**. Control system **300** can be configured and optimized in a variety of ways with more or less subsystems and components to implement the therapeutic system for controlled thermal injury of photoaged tissue, and the embodiments in FIGS. **3A** and **3B** are merely for illustration purposes.

[0036] For example, for power sourcing components **302**, control system **300** can comprise one or more direct current (DC) power supplies **303** configured to provide electrical energy for entire control system **300**, including power required by a transducer electronic amplifier/driver **312**. A DC current sense device **305** can also be provided to confirm the level of power going into amplifiers/drivers **312** for safety and monitoring purposes.

[0037] Amplifiers/drivers **312** can comprise multi-channel or single channel power amplifiers and/or drivers. In accordance with an exemplary embodiment for transducer array configurations, amplifiers/drivers **312** can also be configured with a beamformer to facilitate array focusing. An exemplary beamformer can be electrically excited by an oscillator/digitally controlled waveform synthesizer **310** with related switching logic.

[0038] The power sourcing components can also include various filtering configurations **314**. For example, switchable harmonic filters and/or matching may be used at the output of amplifier/driver **312** to increase the drive efficiency and effectiveness. Power detection components **316** may also be included to confirm appropriate operation and calibration. For example, electric power and other energy detection components **316** may be used to monitor the amount of power going to an exemplary probe system.

[0039] Various sensing and monitoring components **304** may also be suitably implemented within control system **300**. For example, in accordance with an exemplary embodiment, monitoring, sensing and interface control components **324** may be configured to operate with various motion detection systems implemented within transducer probe **204** to receive and process information such as acoustic or other spatial and temporal information from a region of interest. Sensing and monitoring components can also include various controls, interfacing and switches **309** and/or power detectors **316**. Such sensing and monitoring components **304** can facilitate open-loop and/or closed-loop feedback systems within treatment system **200**.

[0040] Cooling/coupling control systems **306** may be provided to remove waste heat from an exemplary probe **204**, provide a controlled temperature at the superficial tissue interface and deeper into tissue, and/or provide acoustic coupling from transducer probe **204** to region-of-interest **206**. Such cooling/coupling control systems **306** can also be configured to operate in both open-loop and/or closed-loop feedback arrangements with various coupling and feedback components.

[0041] Processing and control logic components **308** can comprise various system processors and digital control logic **307**, such as one or more of microcontrollers, microprocessors, field-programmable gate arrays (FPGAs), computer boards, and associated components, including firmware and control software **326**, which interfaces to user controls and interfacing circuits as well as input/output circuits and systems for communications, displays, interfacing, storage,

documentation, and other useful functions. System software and firmware **326** controls all initialization, timing, level setting, monitoring, safety monitoring, and all other system functions required to accomplish user-defined treatment objectives. Further, various control switches **308** can also be suitably configured to control operation.

[0042] An exemplary transducer probe **204** can also be configured in various manners and comprise a number of reusable and/or disposable components and parts in various embodiments to facilitate its operation. For example, transducer probe **204** can be configured within any type of transducer probe housing or arrangement for facilitating the coupling of transducer to a tissue interface, with such housing comprising various shapes, contours and configurations. Transducer probe **204** can comprise any type of matching, such as for example, electric matching, which may be electrically switchable; multiplexer circuits and/or aperture/element selection circuits; and/or probe identification devices, to certify probe handle, electric matching, transducer usage history and calibration, such as one or more serial EEPROM (memories). Transducer probe **204** may also comprise cables and connectors; motion mechanisms, motion sensors and encoders; thermal monitoring sensors; and/or user control and status related switches, and indicators such as LEDs. For example, a motion mechanism in probe **204** may be used to controllably create multiple lesions, or sensing of probe motion itself may be used to controllably create multiple lesions and/or stop creation of lesions, e.g. for safety reasons if probe **204** is suddenly jerked or is dropped. In addition, an external motion encoder arm may be used to hold the probe during use, whereby the spatial position and attitude of probe **104** is sent to the control system to help controllably create lesions. Furthermore, other sensing functionality such as profilometers or other imaging modalities may be integrated into the probe in accordance with various exemplary embodiments.

[0043] With reference to FIGS. **4A** and **4B**, in accordance with an exemplary embodiment, a transducer probe **400** can comprise a control interface **402**, a transducer **404**, coupling components **406**, and monitoring/sensing components **408**, and/or motion mechanism **410**. However, transducer probe **400** can be configured and optimized in a variety of ways with more or less parts and components to provide ultrasound energy for controlled thermal injury of photoaged tissue, and the embodiments in FIGS. **4A** and **4B** are merely for illustration purposes.

[0044] Control interface **402** is configured for interfacing with control system **300** to facilitate control of transducer probe **400**. Control interface components **402** can comprise multiplexer/aperture select **424**, switchable electric matching networks **426**, serial EEPROMs and/or other processing components and matching and probe usage information **430** and interface connectors **432**.

[0045] Coupling components **406** can comprise various devices to facilitate coupling of transducer probe **400** to a region of interest. For example, coupling components **406** can comprise cooling and acoustic coupling system **420** configured for acoustic coupling of ultrasound energy and signals. Acoustic cooling/coupling system **420** with possible connections such as manifolds may be utilized to couple sound into the region-of-interest, control temperature at the interface and deeper into tissue, provide liquid-filled lens focusing, and/or to remove transducer waste heat. Coupling system **420** may facilitate such coupling through use of

various coupling mediums, including air and other gases, water and other fluids, gels, solids, and/or any combination thereof, or any other medium that allows for signals to be transmitted between transducer active elements **412** and a region of interest. In addition to providing a coupling function, in accordance with an exemplary embodiment, coupling system **420** can also be configured for providing temperature control during the treatment application. For example, coupling system **420** can be configured for controlled cooling of an interface surface or deeper region between transducer probe **400** and a region of interest and beyond by suitably controlling the temperature of the coupling medium. The suitable temperature for such coupling medium can be achieved in various manners, and utilize various feedback systems, such as thermocouples, thermistors or any other device or system configured for temperature measurement of a coupling medium. Such controlled cooling can be configured to further facilitate spatial and/or thermal energy delivery control of transducer probe **400**.

[0046] In accordance with an exemplary embodiment, with additional reference to FIG. 11, acoustic coupling and cooling **1140** can be provided to acoustically couple energy and imaging signals from transducer probe **1104** to and from the region of interest **1102**, to provide thermal control at the probe to region-of-interest interface **1110** and deeper into tissue, and to remove potential waste heat from the transducer probe at region **1144**. Temperature monitoring can be provided at the coupling interface via a thermal sensor **1146** to provide a mechanism of temperature measurement **1148** and control via control system **1106** and a thermal control system **1142**. Thermal control may consist of passive cooling such as via heat sinks or natural conduction and convection or via active cooling such as with peltier thermoelectric coolers, refrigerants, or fluid-based systems comprised of pump, fluid reservoir, bubble detection, flow sensor, flow channels/tubing **1144** and thermal control **1142**.

[0047] With continued reference to FIG. 4, monitoring and sensing components **408** can comprise various motion and/or position sensors **416**, temperature monitoring sensors **418**, user control and feedback switches **414** and other like components for facilitating control by control system **300**, e.g., to facilitate spatial and/or temporal control through open-loop and closed-loop feedback arrangements that monitor various spatial and temporal characteristics.

[0048] Motion mechanism **410** can comprise manual operation, mechanical arrangements, or some combination thereof. For example, a motion mechanism **422** can be suitably controlled by control system **300**, such as through the use of accelerometers, encoders or other position/orientation devices **416** to determine and enable movement and positions of transducer probe **400**. Linear, rotational or variable movement can be facilitated, e.g., those depending on the treatment application and tissue contour surface.

[0049] Transducer **404** can comprise one or more transducers configured for treating of SMAS layers and targeted regions. Transducer **404** can also comprise one or more transduction elements and/or lenses **412**. The transduction elements can comprise a piezoelectrically active material, such as lead zirconate titanate (PZT), or any other piezoelectrically active material, such as a piezoelectric ceramic, crystal, plastic, and/or composite materials, as well as lithium niobate, lead titanate, barium titanate, and/or lead metaniobate. In addition to, or instead of, a piezoelectrically active material, transducer **404** can comprise any other

materials configured for generating radiation and/or acoustical energy. Transducer **404** can also comprise one or more matching layers configured along with the transduction element such as coupled to the piezoelectrically active material. Acoustic matching layers and/or damping may be employed as necessary to achieve the desired electroacoustic response.

[0050] In accordance with an exemplary embodiment, the thickness of the transduction element of transducer **404** can be configured to be uniform. That is, a transduction element **412** can be configured to have a thickness that is substantially the same throughout. In accordance with another exemplary embodiment, the thickness of a transduction element **412** can also be configured to be variable. For example, transduction element(s) **412** of transducer **404** can be configured to have a first thickness selected to provide a center operating frequency of approximately 2 kHz to 75 MHz, such as for imaging applications. Transduction element **412** can also be configured with a second thickness selected to provide a center operating frequency of approximately 2 to 50 MHz, and typically between 2 MHz and 25 MHz for therapy application. Transducer **404** can be configured as a single broadband transducer excited with at least two or more frequencies to provide an adequate output for generating a desired response. Transducer **404** can also be configured as two or more individual transducers, wherein each transducer comprises one or more transduction element. The thickness of the transduction elements can be configured to provide center-operating frequencies in a desired treatment range.

[0051] Transducer **404** may be composed of one or more individual transducers in any combination of focused, planar, or unfocused single-element, multi-element, or array transducers, including 1-D, 2-D, and annular arrays; linear, curvilinear, sector, or spherical arrays; spherically, cylindrically, and/or electronically focused, defocused, and/or lensed sources. For example, with reference to an exemplary embodiment depicted in FIG. 5, transducer **500** can be configured as an acoustic array **502** to facilitate phase focusing. That is, transducer **500** can be configured as an array of electronic apertures that may be operated by a variety of phases via variable electronic time delays. By the term "operated," the electronic apertures of transducer **500** may be manipulated, driven, used, and/or configured to produce and/or deliver an energy beam corresponding to the phase variation caused by the electronic time delay. For example, these phase variations can be used to deliver defocused beams **508**, planar beams **504**, and/or focused beams **506**, each of which may be used in combination to achieve different physiological effects in a region of interest **510**. Transducer **500** may additionally comprise any software and/or other hardware for generating, producing and/or driving a phased aperture array with one or more electronic time delays.

[0052] Transducer **500** can also be configured to provide focused treatment to one or more regions of interest using various frequencies. In order to provide focused treatment, transducer **500** can be configured with one or more variable depth devices to facilitate treatment. For example, transducer **500** may be configured with variable depth devices disclosed in U.S. patent application Ser. No. 10/944,500, entitled "System and Method for Variable Depth Ultrasound", filed on Sep. 16, 2004, having at least one common inventor and a common Assignee as the present application,

and incorporated herein by reference. In addition, transducer **500** can also be configured to treat one or more additional ROI **510** through the enabling of sub-harmonics or pulse echo imaging, as disclosed in U.S. patent application Ser. No. 10/944,499, entitled "Method and System for Ultrasound Treatment with a Multi-directional Transducer," filed on Sep. 16, 2004, having at least one common inventor and a common Assignee as the present application, and also incorporated herein by reference.

[0053] Moreover, any variety of mechanical lenses or variable focus lenses, e.g. liquid-filled lenses, may also be used to focus and/or defocus the sound field. For example, with reference to exemplary embodiments depicted in FIGS. **6A** and **6B**, transducer **600** may also be configured with an electronic focusing array **604** in combination with one or more transduction elements **606** to facilitate increased flexibility in treating ROI **610**. Array **604** may be configured in a manner similar to transducer **502**. That is, array **604** can be configured as an array of electronic apertures that may be operated by a variety of phases via variable electronic time delays, for example, T<sub>1</sub>, T<sub>2</sub> . . . T<sub>j</sub>. By the term "operated," the electronic apertures of array **604** may be manipulated, driven, used, and/or configured to produce and/or deliver energy in a manner corresponding to the phase variation caused by the electronic time delay. For example, these phase variations can be used to deliver defocused beams, planar beams, and/or focused beams, each of which may be used in combination to achieve different physiological effects in ROI **610**.

[0054] Transduction elements **606** may be configured to be concave, convex, and/or planar. For example, in an exemplary embodiment depicted in FIG. **6A**, transduction elements **606** are configured to be concave in order to provide focused energy for treatment of ROI **610**. Additional embodiments are disclosed in U.S. patent application Ser. No. 10/944,500, entitled "Variable Depth Transducer System and Method", and again incorporated herein by reference.

[0055] In another exemplary embodiment, depicted in FIG. **6B**, transduction elements **606** can be configured to be substantially flat in order to provide substantially uniform energy to ROI **610**. While FIGS. **6A** and **6B** depict exemplary embodiments with transduction elements **604** configured as concave and substantially flat, respectively, transduction elements **604** can be configured to be concave, convex, and/or substantially flat. In addition, transduction elements **604** can be configured to be any combination of concave, convex, and/or substantially flat structures. For example, a first transduction element can be configured to be concave, while a second transduction element can be configured to be substantially flat.

[0056] With reference to FIGS. **8A** and **8B**, transducer **404** can be configured as single-element arrays, wherein a single-element **802**, e.g., a transduction element of various structures and materials, can be configured with a plurality of masks **804**, such masks comprising ceramic, metal or any other material or structure for masking or altering energy distribution from element **802**, creating an array of energy distributions **808**. Masks **804** can be coupled directly to element **802** or separated by a standoff **806**, such as any suitably solid or liquid material.

[0057] An exemplary transducer **404** can also be configured as an annular array to provide planar, focused and/or defocused acoustical energy. For example, with reference to

FIGS. **10A** and **10B**, in accordance with an exemplary embodiment, an annular array **1000** can comprise a plurality of rings **1012**, **1014**, **1016** to N. Rings **1012**, **1014**, **1016** to N can be mechanically and electrically isolated into a set of individual elements, and can create planar, focused, or defocused waves. For example, such waves can be centered on-axis, such as by methods of adjusting corresponding transmit and/or receive delays, T<sub>1</sub>, T<sub>2</sub>, T<sub>3</sub> . . . T<sub>N</sub>. An electronic focus can be suitably moved along various depth positions, and can enable variable strength or beam tightness, while an electronic defocus can have varying amounts of defocusing. In accordance with an exemplary embodiment, a lens and/or convex or concave shaped annular array **1000** can also be provided to aid focusing or defocusing such that any time differential delays can be reduced. Movement of annular array **800** in one, two or three-dimensions, or along any path, such as through use of probes and/or any conventional robotic arm mechanisms, may be implemented to scan and/or treat a volume or any corresponding space within a region of interest.

[0058] Transducer **404** can also be configured in other annular or non-array configurations for imaging/therapy functions. For example, with reference to FIGS. **10C-10F**, a transducer can comprise an imaging element **1012** configured with therapy element(s) **1014**. Elements **1012** and **1014** can comprise a single-transduction element, e.g., a combined imaging/transducer element, or separate elements, can be electrically isolated **1022** within the same transduction element or between separate imaging and therapy elements, and/or can comprise standoff **1024** or other matching layers, or any combination thereof. For example, with particular reference to FIG. **10F**, a transducer can comprise an imaging element **1012** having a surface **1028** configured for focusing, defocusing or planar energy distribution, with therapy elements **1014** including a stepped-configuration lens configured for focusing, defocusing, or planar energy distribution.

[0059] In accordance with various exemplary embodiments of the present invention, transducer **404** may be configured to provide one, two and/or three-dimensional treatment applications for focusing acoustic energy to one or more regions of interest. For example, as discussed above, transducer **404** can be suitably diced to form a one-dimensional array, e.g., transducer **602** comprising a single array of sub-transduction elements.

[0060] In accordance with another exemplary embodiment, transducer **404** may be suitably diced in two-dimensions to form a two-dimensional array. For example, with reference to FIG. **9**, an exemplary two-dimensional array **900** can be suitably diced into a plurality of two-dimensional portions **902**. Two-dimensional portions **902** can be suitably configured to focus on the treatment region at a certain depth, and thus provide respective slices **904**, **907** of the treatment region. As a result, the two-dimensional array **900** can provide a two-dimensional slicing of the image plane of a treatment region, thus providing two-dimensional treatment.

[0061] In accordance with another exemplary embodiment, transducer **404** may be suitably configured to provide three-dimensional treatment. For example, to provide three-dimensional treatment of a region of interest, with reference again to FIG. **1**, a three-dimensional system can comprise a transducer within probe **104** configured with an adaptive algorithm, such as, for example, one utilizing three-dimensional graphic software, contained in a control system, such

as control system **102**. The adaptive algorithm is suitably configured to receive two-dimensional imaging, temperature and/or treatment or other tissue parameter information relating to the region of interest, process the received information, and then provide corresponding three-dimensional imaging, temperature and/or treatment information.

[0062] In accordance with an exemplary embodiment, with reference again to FIG. 9, an exemplary three-dimensional system can comprise a two-dimensional array **900** configured with an adaptive algorithm to suitably receive **904** slices from different image planes of the treatment region, process the received information, and then provide volumetric information **906**, e.g., three-dimensional imaging, temperature and/or treatment information. Moreover, after processing the received information with the adaptive algorithm, the two-dimensional array **900** may suitably provide therapeutic heating to the volumetric region **906** as desired.

[0063] In accordance with other exemplary embodiments, rather than utilizing an adaptive algorithm, such as three-dimensional software, to provide three-dimensional imaging and/or temperature information, an exemplary three-dimensional system can comprise a single transducer **404** configured within a probe arrangement to operate from various rotational and/or translational positions relative to a target region.

[0064] To further illustrate the various structures for transducer **404**, with reference to FIG. 7, ultrasound therapy transducer **700** can be configured for a single focus, an array of foci, a locus of foci, a line focus, and/or diffraction patterns. Transducer **700** can also comprise single elements, multiple elements, annular arrays, one-, two-, or three-dimensional arrays, broadband transducers, and/or combinations thereof, with or without lenses, acoustic components, and mechanical and/or electronic focusing. Transducers configured as spherically focused single elements **702**, annular arrays **704**, annular arrays with damped regions **706**, line focused single elements **708**, 1-D linear arrays **710**, 1-D curvilinear arrays in concave or convex form, with or without elevation focusing, 2-D arrays, and 3-D spatial arrangements of transducers may be used to perform therapy and/or imaging and acoustic monitoring functions. For any transducer configuration, focusing and/or defocusing may be in one plane or two planes via mechanical focus **720**, convex lens **722**, concave lens **724**, compound or multiple lenses **726**, planar form **728**, or stepped form, such as illustrated in FIG. 10F. Any transducer or combination of transducers may be utilized for treatment. For example, an annular transducer may be used with an outer portion dedicated to therapy and the inner disk dedicated to broadband imaging wherein such imaging transducer and therapy transducer have different acoustic lenses and design, such as illustrated in FIG. 10C-10F.

[0065] Moreover, such transduction elements **700** may comprise a piezoelectrically active material, such as lead zirconate titanate (PZT), or any other piezoelectrically active material, such as a piezoelectric ceramic, crystal, plastic, and/or composite materials, as well as lithium niobate, lead titanate, barium titanate, and/or lead metaniobate. Transduction elements **700** may also comprise one or more matching layers configured along with the piezoelectrically active material. In addition to or instead of piezoelectrically active material, transduction elements **700** can comprise any other materials configured for generating radiation and/or

acoustical energy. A means of transferring energy to and from the transducer to the region of interest is provided.

[0066] In accordance with another exemplary embodiment, with reference to FIG. 12, an exemplary treatment system **200** can be configured with and/or combined with various auxiliary systems to provide additional functions. For example, an exemplary treatment system **1200** for treating a region of interest **1202** can comprise a control system **1206**, a probe **1204**, and a display **1208**. Treatment system **1200** further comprises an auxiliary imaging modality **1272** and/or auxiliary monitoring modality **1274** may be based upon at least one of photography and other visual optical methods, magnetic resonance imaging (MRI), computed tomography (CT), optical coherence tomography (OCT), electromagnetic, microwave, or radio frequency (RF) methods, positron emission tomography (PET), infrared, ultrasound, acoustic, or any other suitable method of visualization, localization, or monitoring of epidermal, superficial dermal, mid-dermal and deep dermal components within the region-of-interest **1202**, including imaging/monitoring enhancements. Such imaging/monitoring enhancement for ultrasound imaging via probe **1204** and control system **1206** could comprise M-mode, persistence, filtering, color, Doppler, and harmonic imaging among others; furthermore an ultrasound treatment system **1270**, as a primary source of treatment, may be combined with a secondary source of treatment **1276**, including radio frequency (RF), intense pulsed light (IPL), laser, infrared laser, microwave, or any other suitable energy source.

[0067] In accordance with another exemplary embodiment, with reference to FIG. 13, treatment composed of imaging, monitoring, and/or therapy to a region of interest **1302** and/or **1308** may be aided, augmented, and/or delivered with passive or active devices **1304** and/or **1306** within the oral and/or nasal cavity, respectively. For example, if passive or active device **1304** and/or **1306** are second transducers or acoustic reflectors acoustically coupled to the mucous membranes it is possible to obtain through transmission, tomographic, or round-trip acoustic waves which are useful for treatment monitoring, such as in measuring acoustic speed of sound and attenuation, which are temperature dependent; furthermore such transducers could be used to treat and/or image. In addition an active, passive, or active/passive object **1304** and/or **1306** may be used to flatten the skin, and/or may be used as an imaging grid, marker, or beacon, to aid determination of position. A passive or active device **1304** and/or **1306** may also be used to aid cooling or temperature control. Natural air in the oral cavity and/or nasal cavity may also be used as passive device **1304** and/or **1306** whereby it may be utilized to as an acoustic reflector to aid thickness measurement and monitoring function.

[0068] The present invention has been described above with reference to various exemplary embodiments. However, those skilled in the art will recognize that changes and modifications may be made to the exemplary embodiments without departing from the scope of the present invention. For example, the various operational steps, as well as the components for carrying out the operational steps, may be implemented in alternate ways depending upon the particular application or in consideration of any number of cost functions associated with the operation of the system, e.g., various of the steps may be deleted, modified, or combined with other steps. These and other changes or modifications

are intended to be included within the scope of the present invention, as set forth in the following claims.

What is claimed is:

1. An ultrasound treatment system configured for treatment of the photoaged effects in tissue, said ultrasound treatment system comprising:

a control system for facilitating control of the ultrasound treatment system;

a display system for displaying an image of at least one of epidermal, superficial dermal, mid-dermal and deep dermal tissues within a region of interest, said display system coupled to said control system; and

a probe system configured for targeted delivery of ultrasound energy producing arrays of sub-millimeter and larger zones of thermal ablation to treat said at least one of said epidermal, superficial dermal, mid-dermal and deep dermal tissue to cause reduction of the photoaged effects in tissue.

\* \* \* \* \*

专利名称(译)	超声探头治疗皮肤松弛		
公开(公告)号	<a href="#">US20190184207A1</a>	公开(公告)日	2019-06-20
申请号	US16/284907	申请日	2019-02-25
申请(专利权)人(译)	引导治疗系统, L.L.C.		
当前申请(专利权)人(译)	引导治疗系统, L.L.C.		
[标]发明人	BARTHE PETER G SLAYTON MICHAEL H MAKIN INDER RAJ S		
发明人	BARTHE, PETER G. SLAYTON, MICHAEL H. MAKIN, INDER RAJ S.		
IPC分类号	A61N7/02 A61B5/00 A61B8/08 G01S15/89 A61B8/12 A61B8/13 A61B8/00 A61N7/00 A61H23/02 A61B17/32		
CPC分类号	A61B8/4209 A61N2007/0008 A61N2007/0034 A61N2007/0052 A61N2007/027 A61N7/02 A61B5/6842 A61B8/483 G01S15/8909 A61B8/08 A61B8/0858 A61B8/12 A61B8/13 A61B8/4483 A61B8/461 A61N7 /00 A61H23/0245 A61B17/320068 A61B8/546 A61B5/682 A61B8/4281 A61B8/4455 A61H2201/5007 A61B2017/320069 A61B2017/320089		
优先权	60/617295 2004-10-07 US		
其他公开文献	US10610705		
外部链接	<a href="#">Espacenet</a> <a href="#">USPTO</a>		

摘要(译)

提供了一种用于皮肤松弛的超声治疗的探针。系统和方法可以包括感兴趣区域的超声成像，用于治疗区域的定位，以深度和模式递送超声能量以实现期望的治疗效果，和/或监测治疗区域以评估结果和/或提供反馈。在一个实施例中，治疗系统和方法可以被配置用于产生亚毫米和更大的热消融区域的阵列，以治疗组织的表皮，浅表真皮，中真皮或深层皮肤组件。

