



US 20160192900A1

(19) **United States**

(12) **Patent Application Publication**
ABDULLAH et al.

(10) **Pub. No.: US 2016/0192900 A1**

(43) **Pub. Date: Jul. 7, 2016**

(54) **DEVICE FOR UTILIZING TRANSMISSION
ULTRASONOGRAPHY TO ENABLE
ULTRASOUND-GUIDED PLACEMENT OF
CENTRAL VENOUS CATHETERS**

Publication Classification

(51) **Int. Cl.**
A61B 8/12 (2006.01)
A61B 8/08 (2006.01)
A61B 8/00 (2006.01)

(52) **U.S. Cl.**
 CPC *A61B 8/12* (2013.01); *A61B 8/4218*
 (2013.01); *A61B 8/0841* (2013.01); *A61B*
8/4483 (2013.01); *A61B 8/445* (2013.01)

(71) Applicant: **THE JOHNS HOPKINS
UNIVERSITY**, Baltimore, MD (US)

(72) Inventors: **Fizan ABDULLAH**, Baltimore, MD
(US); **Seth GOLDSTEIN**, Baltimore,
MD (US); **Emad BOCTOR**, Baltimore,
MD (US)

(57) **ABSTRACT**
 Ultrasound is typically performed with the use of an external
 transcutaneous probe that emits ultrasonic energy and mea-
 sures the timing of reflected waves, thus allowing measure-
 ment of fluid flow or formation of a two-dimensional image.
 Clinically, the modality is limited by attenuation of the signal
 with increasing depth of penetration of the ultrasound into
 tissues, as well as by similarities in echo-genicity between
 different tissues. The present invention includes a system in
 which an intravascular probe actively transmits ultrasound
 that can then be detected by in-line piezoelectric transducers
 without reflection. This signal can be overlaid onto traditional
 B-mode or Doppler representation. Furthermore, the present
 invention includes a signal processing system that will dis-
 play a real-time graphical representation of the vascular
 anatomy in order to assist the surgeon or procedural radiolo-
 gist in the placement of central venous catheters.

(21) Appl. No.: **14/916,260**

(22) PCT Filed: **Aug. 1, 2014**

(86) PCT No.: **PCT/US2014/049353**

§ 371 (c)(1),
(2) Date: **Mar. 3, 2016**

Related U.S. Application Data

(60) Provisional application No. 61/872,903, filed on Sep.
3, 2013.

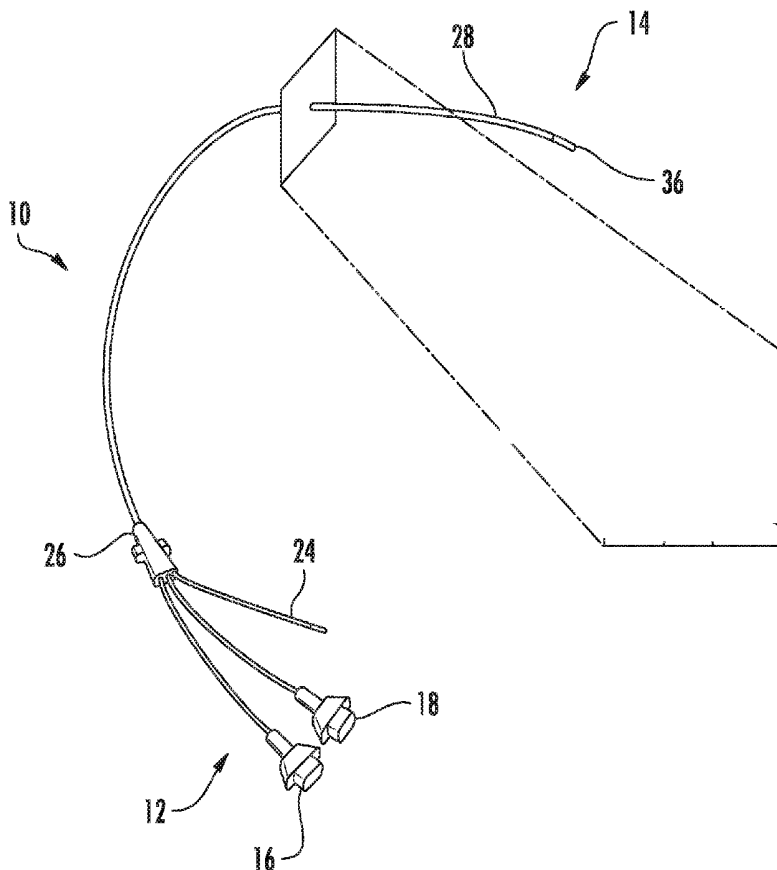

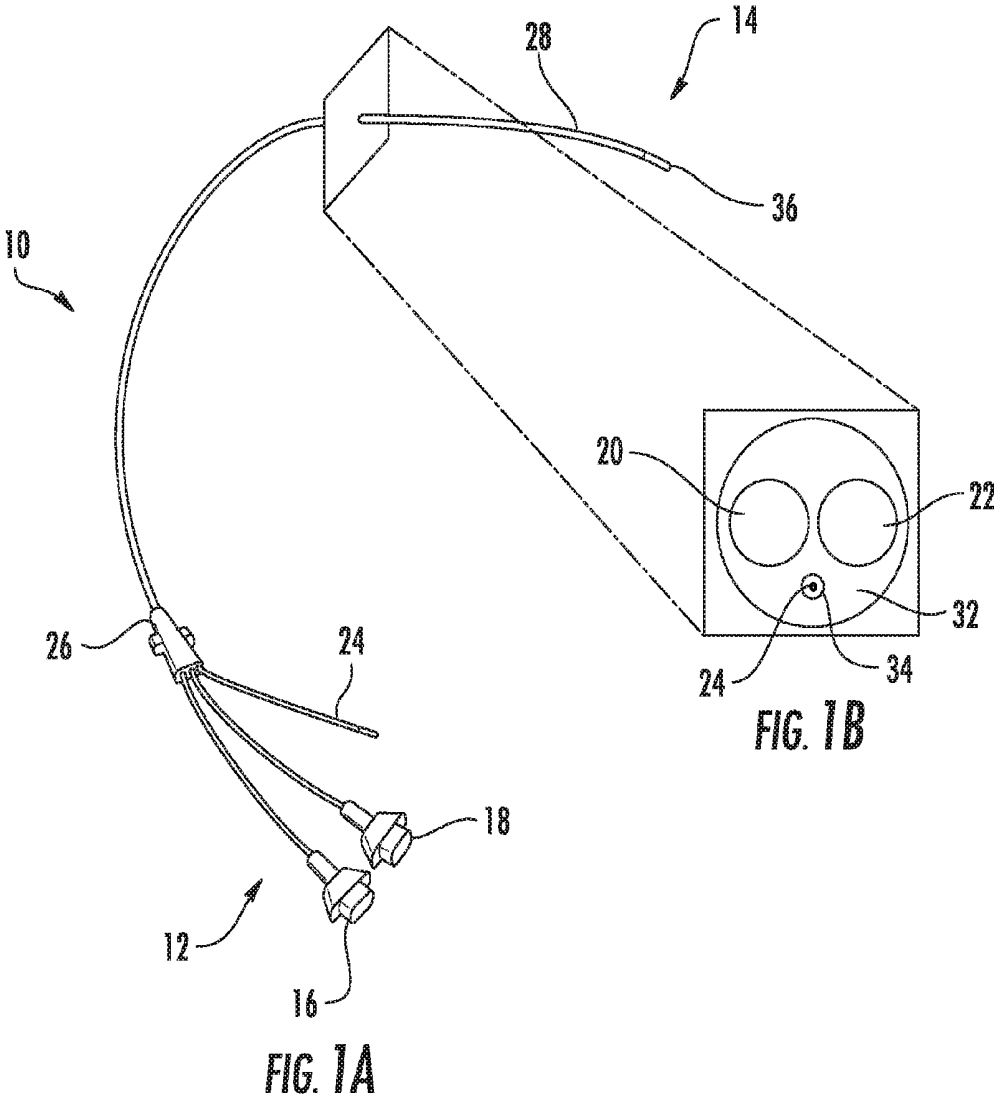

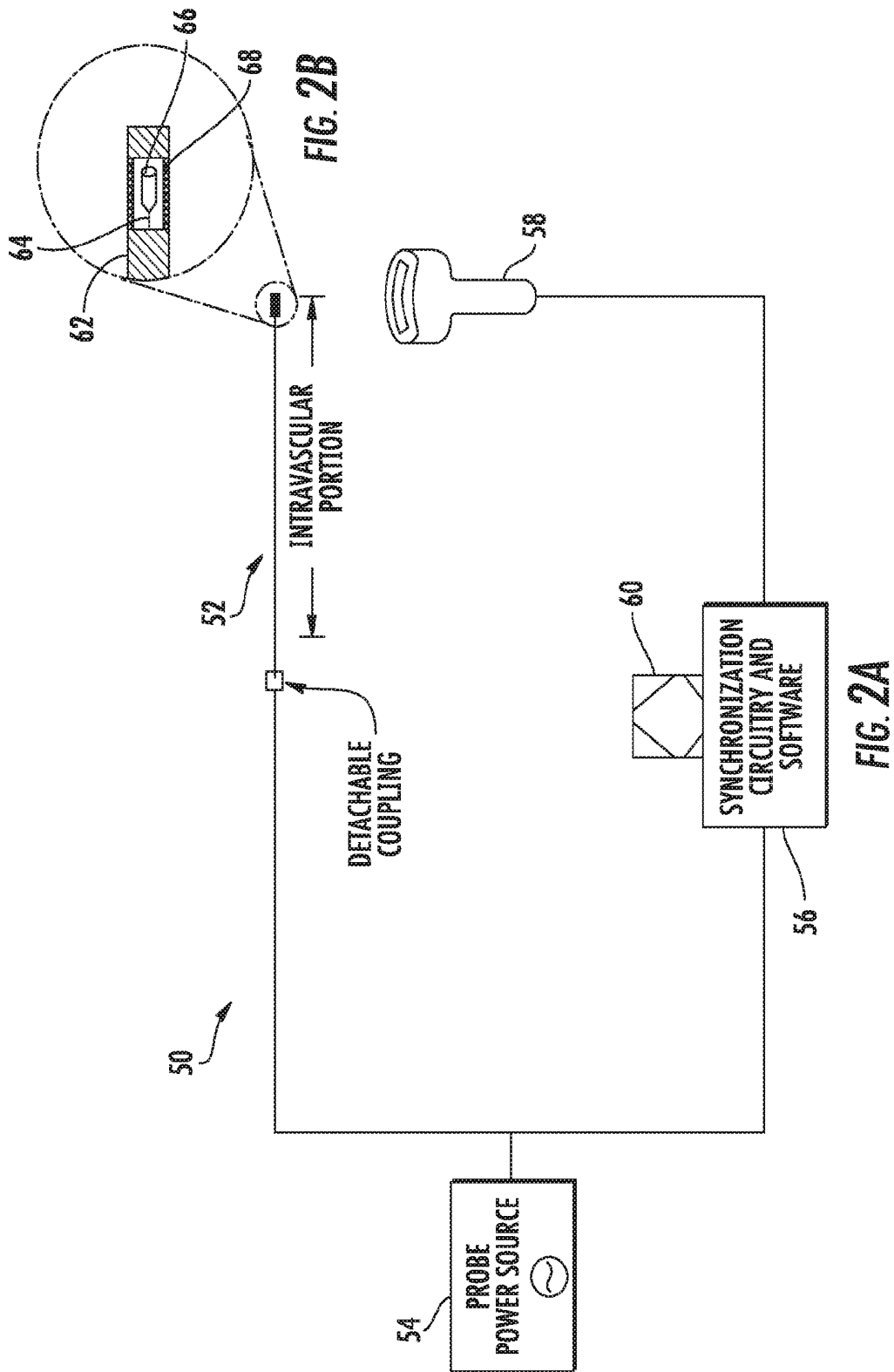

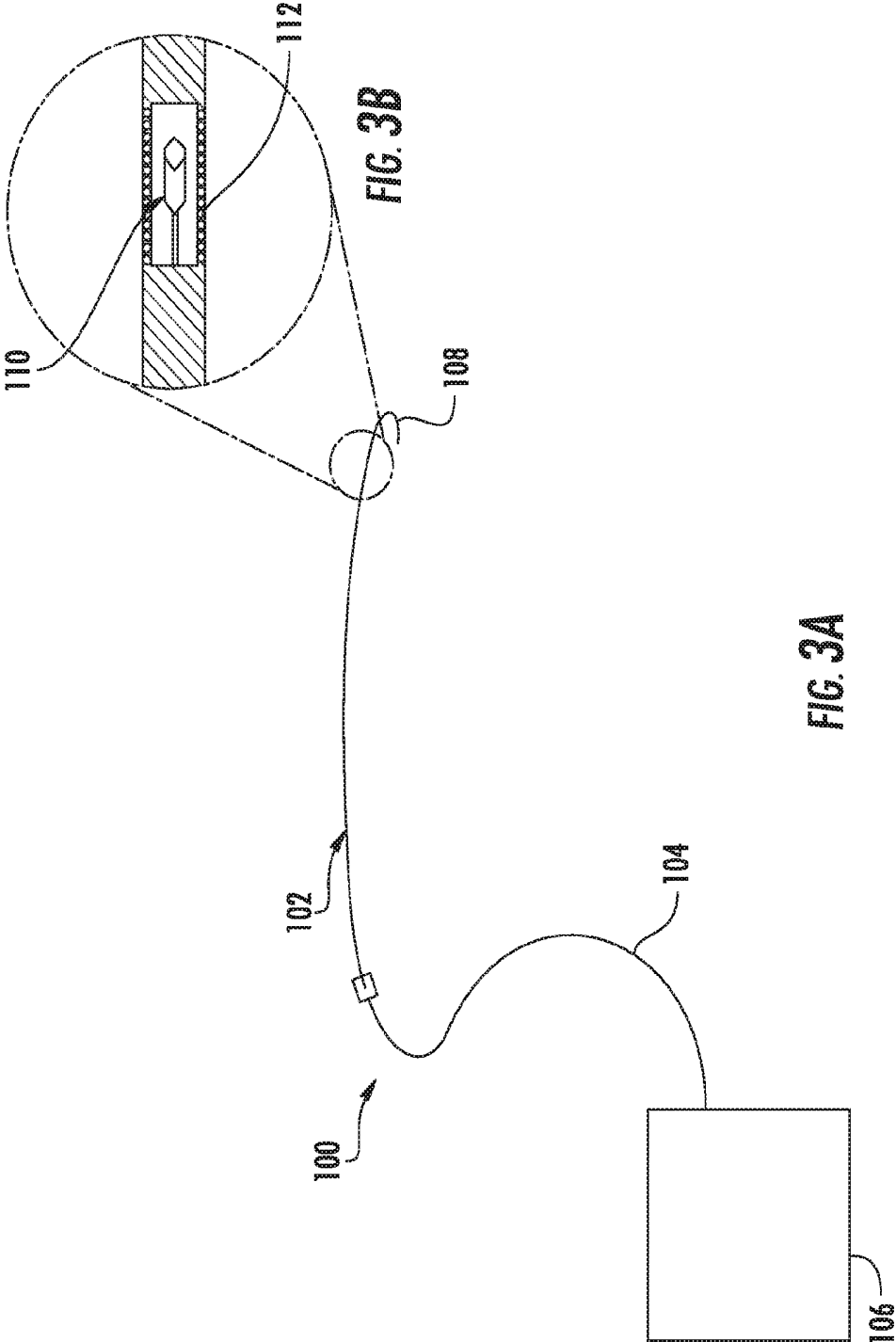

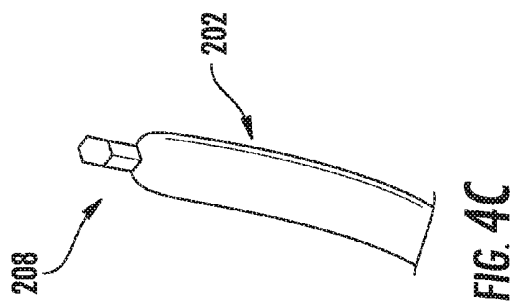
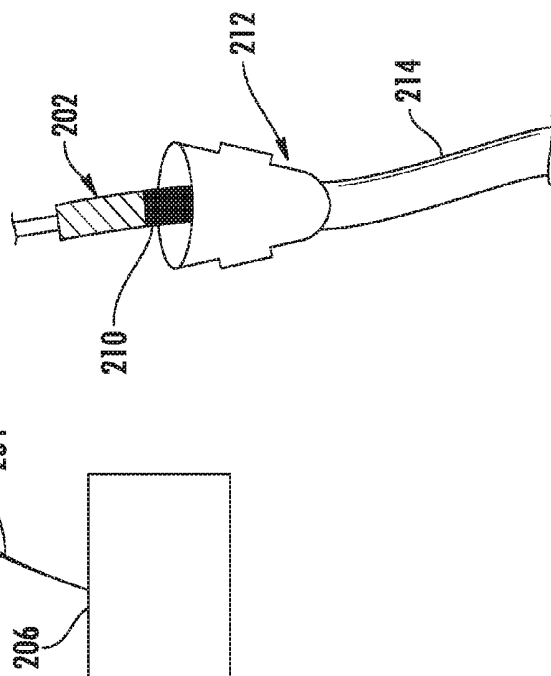
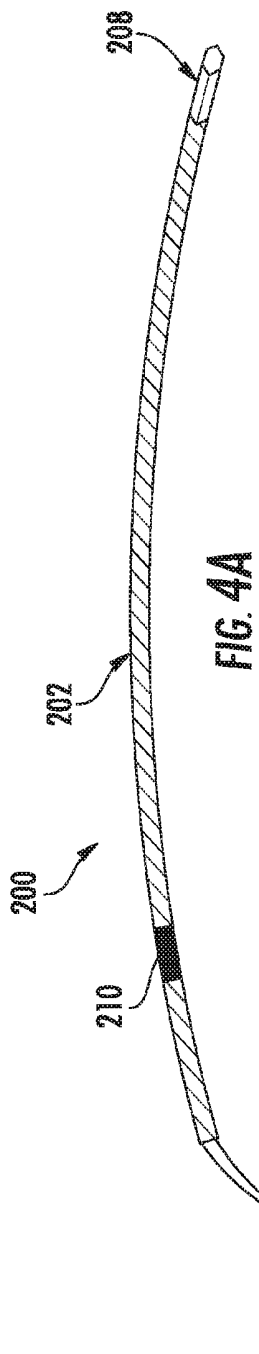

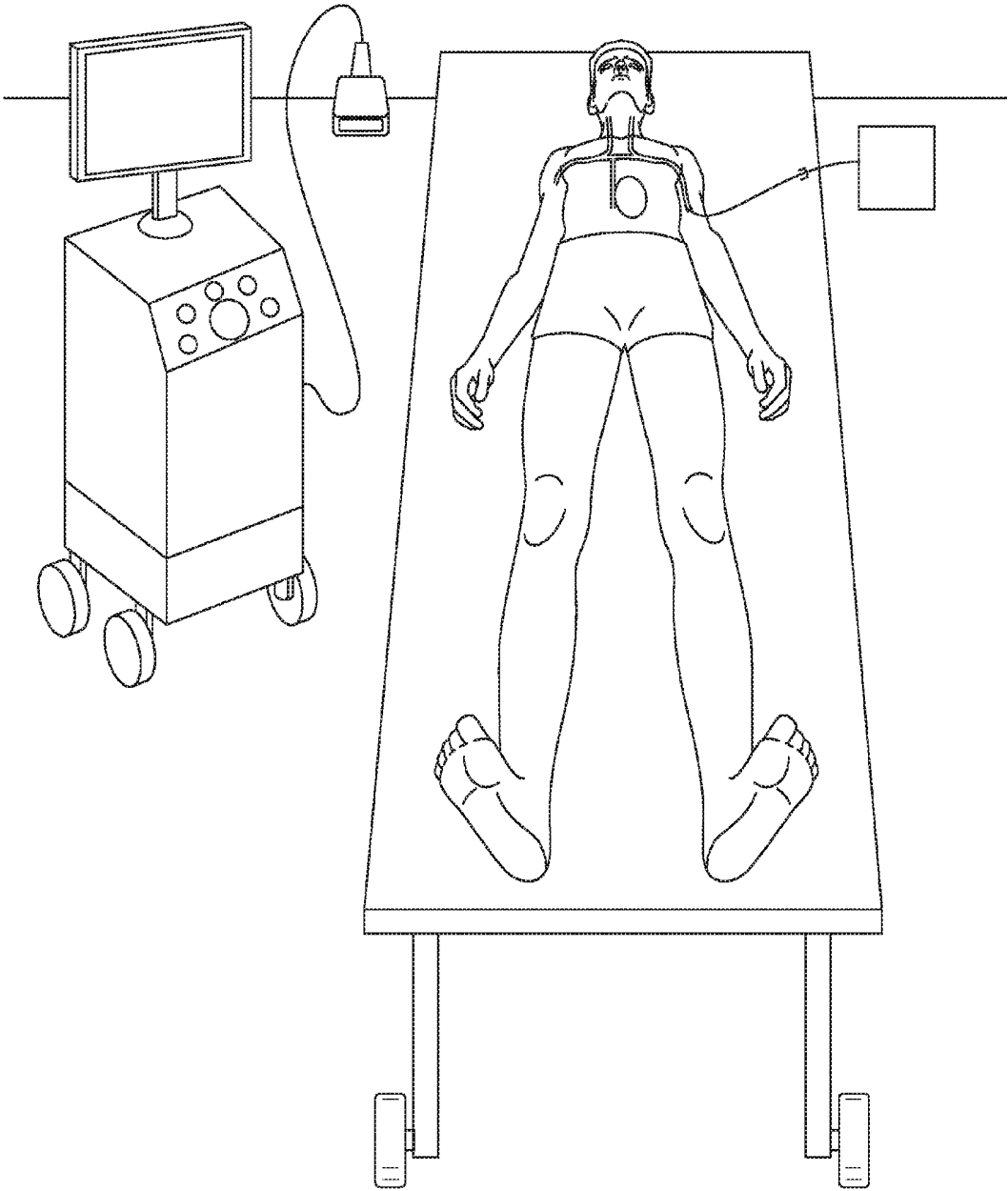

FIG. 5

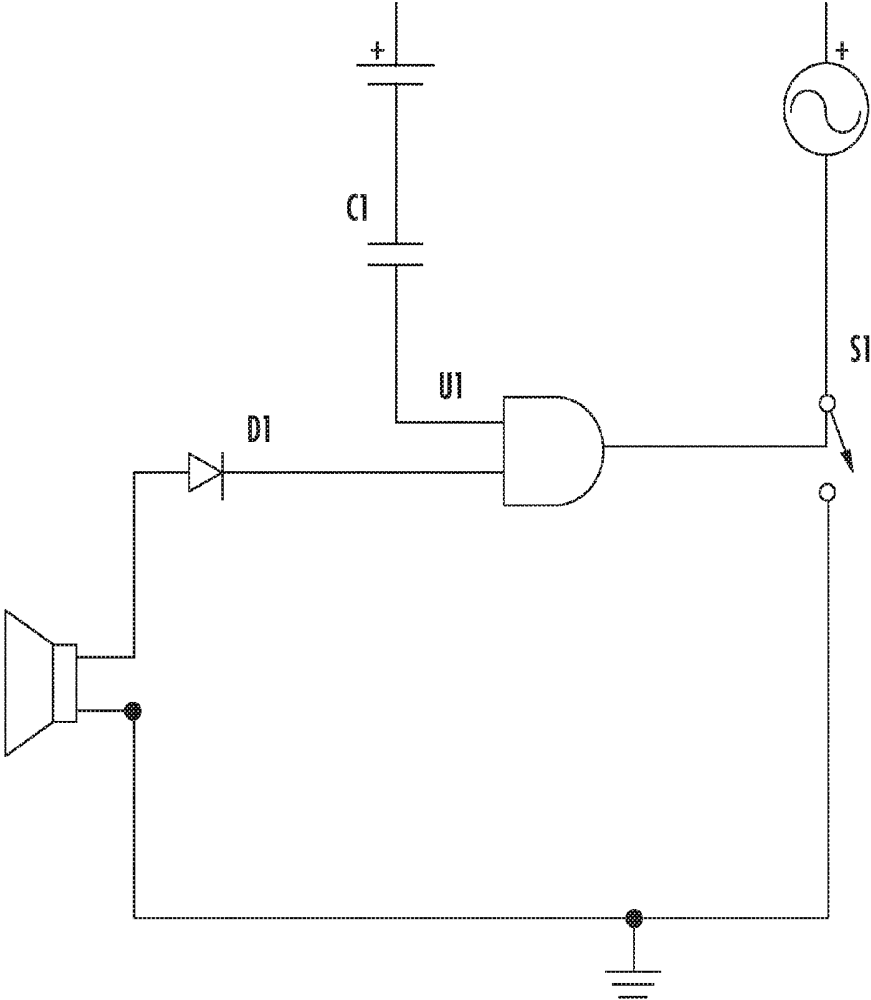
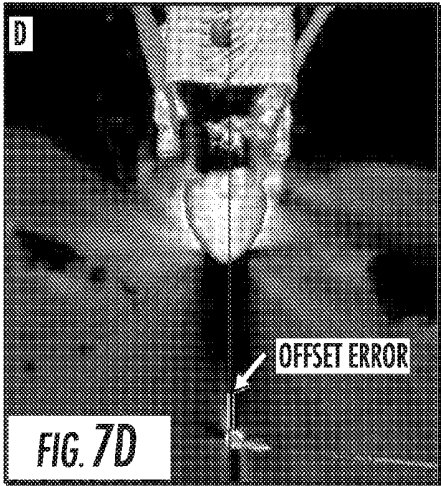
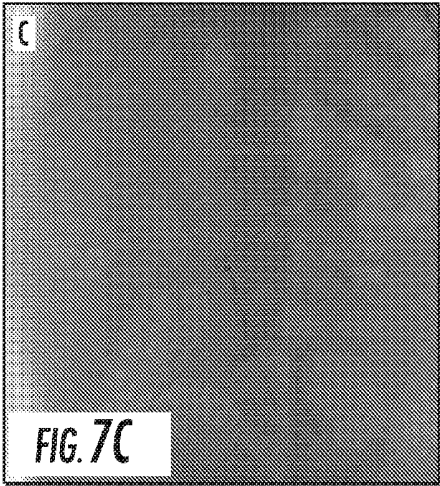
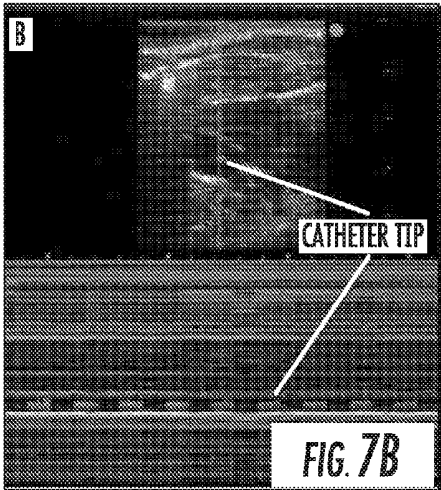
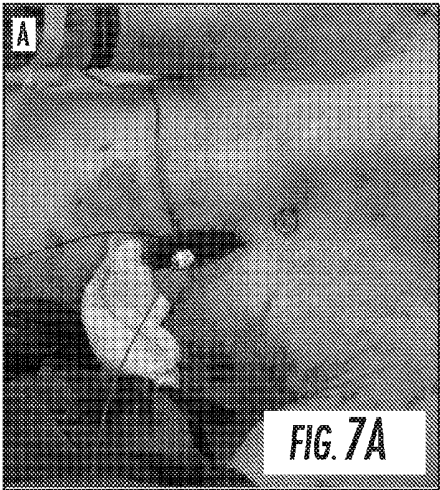

FIG. 6



**DEVICE FOR UTILIZING TRANSMISSION
ULTRASONOGRAPHY TO ENABLE
ULTRASOUND-GUIDED PLACEMENT OF
CENTRAL VENOUS CATHETERS**

CROSS REFERENCE TO RELATED
APPLICATION

[0001] This application claims the benefit of U.S. Provisional Patent Application No. 61/872,903 filed on Sep. 3, 2013, which is incorporated by reference, herein, in its entirety.

FIELD OF THE INVENTION

[0002] The present invention relates generally to medical imaging. More particularly, the present invention relates to a device for image guided placement of a central venous catheter.

BACKGROUND OF THE INVENTION

[0003] Central venous catheters have many uses and are used in patients of all ages, including pediatric patients. Central venous catheters are generally inserted using the Seldinger technique. First, a blunt guidewire is passed through a needle inserted into the vein. The progress and position of the guidewire can be monitored using fluoroscopy. After the guidewire is positioned, a stiff introducer is inserted, the guidewire is removed, and the catheter is passed into the vein within the introducer. Once the catheter is positioned, more fluoroscopic images are obtained to confirm correct placement of the catheter. However, the amount of radiation involved in this procedure is not ideal, particularly for small children.

[0004] Accordingly, there is a need in the art for an imaging device to guide placement of a central venous catheter that emits little to no ionizing radiation, especially for pediatric patients.

SUMMARY OF THE INVENTION

[0005] The foregoing needs are met, to a great extent, by the present invention which provides a system for intravascular transmission ultrasonography, including an intravascular probe having a proximal end and a distal end, wherein the intravascular probe is configured to produce ultrasonic energy. The system includes a catheter having a proximal end and a distal end, and also being configured to transmit ultrasonic energy. The system also includes a detection probe configured to detect ultrasonic energy from the intravascular probe and the catheter and a computing device configured to process and display information from the ultrasound probe.

[0006] In accordance with an aspect of the present invention, the intravascular probe includes a piezoelectric device. The piezoelectric device is disposed at a distal end of the intravascular probe. The catheter also includes a piezoelectric device that can be disposed at the distal end of the catheter. The detection probe takes the form of a blanket array, or alternately the detection probe takes the form of a single probe disposed on a robotic arm. The computing device can include a non-transitory computer readable medium. Additionally, the intravascular probe can take the form of a seldinger-type wire, and the catheter can take the form of a central venous catheter.

BRIEF DESCRIPTION OF THE DRAWINGS

[0007] The accompanying drawings provide visual representations, which will be used to more fully describe the representative embodiments disclosed herein and can be used by those skilled in the art to better understand them and their inherent advantages. In these drawings, like reference numerals identify corresponding elements and:

[0008] FIG. 1A illustrates a perspective view of a central venous catheter according to an embodiment of the present invention.

[0009] FIG. 1B illustrates a sectional view of the central venous catheter of FIG. 1A taken along a transverse axis of the catheter.

[0010] FIG. 2A illustrates a schematic diagram of a ultrasound imaging system for placement of a central venous catheter.

[0011] FIG. 2B illustrates a sectional view of a distal end of an intravascular probe, according to an embodiment of the present invention.

[0012] FIG. 3A illustrates a schematic diagram of a guide wire for a system for ultrasound imaging for placement of a central venous catheter, according to an embodiment of the present invention.

[0013] FIG. 3B illustrates a sectional view of a portion of a guide wire of FIG. 3A, according to an embodiment of the present invention.

[0014] FIG. 4A illustrates a schematic diagram of a stylet for a system for ultrasound imaging for placement of a central venous catheter, according to an embodiment of the present invention.

[0015] FIGS. 4B and 4C illustrate a miniature piezoelectric transducer disposed at a tip of the stylet of FIG. 4A, according to an embodiment of the present invention.

[0016] FIG. 5 illustrates a diagram of a proposed clinical use, according to an embodiment of the present invention.

[0017] FIG. 6 illustrates a schematic diagram of a circuit according to an embodiment of the present invention.

[0018] FIGS. 7A-7D illustrate an exemplary implementation of the present invention.

DETAILED DESCRIPTION

[0019] The presently disclosed subject matter now will be described more fully hereinafter with reference to the accompanying Drawings, in which some, but not all embodiments of the inventions are shown. Like numbers refer to like elements throughout. The presently disclosed subject matter may be embodied in many different forms and should not be construed as limited to the embodiments set forth herein; rather, these embodiments are provided so that this disclosure will satisfy applicable legal requirements. Indeed, many modifications and other embodiments of the presently disclosed subject matter set forth herein will come to mind to one skilled in the art to which the presently disclosed subject matter pertains having the benefit of the teachings presented in the foregoing descriptions and the associated Drawings. Therefore, it is to be understood that the presently disclosed subject matter is not to be limited to the specific embodiments disclosed and that modifications and other embodiments are intended to be included within the scope of the appended claims.

[0020] The present invention is directed to a system to enable ultrasound-guided placement of a central venous catheter (CVC). Ultrasound is typically performed with the use of

an external transcutaneous probe that emits ultrasonic energy and measures the timing of reflected waves, thus allowing measurement of fluid flow or formation of a two-dimensional image. Clinically, the modality is limited by attenuation of the signal with increasing depth of penetration of the ultrasound into tissues. The present invention includes a system in which an intravascular probe actively transmits ultrasound that can then be detected by in-line piezoelectric transducers without reflection. This signal can be overlaid onto traditional B-mode or Doppler representation. Furthermore, the present invention includes a signal processing system that will display a real-time graphical representation of the vascular anatomy in order to assist the surgeon or procedural radiologist in the placement of central venous catheters.

[0021] A system for transmission ultrasonography guided placement of a central venous catheter or other similar device, according to the present invention, includes a Seldinger-style wire configured to be capable of producing ultrasonic energy after intravascular placement with an introducer sheath. The system also includes a catheter also configured to be capable of producing ultrasonic energy after intravascular placement. Additionally, the system includes a detection probe of piezoelectric transducers, either in a blanket array or a single probe on a robotic arm and processing software that permits a stylized representation of the intravascular anatomy and wire/catheter location.

[0022] FIG. 1A illustrates a perspective view of a central venous catheter with ultrasonic capabilities, according to an embodiment of the present invention. As illustrated in FIG. 1A the central venous catheter 10 includes a proximal end 12 and a distal end 14. The proximal end 12 of the central venous catheter 10 includes at least two fluid ports 16, 18. These fluid ports are in fluid communication with fluid lumens 20, 22, illustrated in FIG. 1B. The fluid lumens 20, 22 extend from the proximal end 12 to the distal end 14 of the catheter 10. The fluid ports 16, 18 and fluid lumens 20, 22 are configured for the delivery of any substance known to or conceivable by one of skill in the art. The fluid ports 16, 18 can take any suitable form known to or conceivable by one of skill in the art, and the lumens 20, 22 can have equivalent diameters, as illustrated in FIG. 1B or can have different diameters, as is known to or conceivable by one of skill in the art. The catheter 10 also includes an electrode 24. The electrode 24 extends from the proximal end 12 to the distal end 14 of the catheter 10. The electrode 24 can have a proximal end 26 and a distal end 28. The proximal end 26 of the electrode 24 includes a detachable coupling 30, or any other suitable coupling known to or conceivable by one of skill in the art. The electrode 24 extends through the catheter 10, as illustrated in FIG. 1B. The electrode 24 can be embedded in the wall 32 of the catheter 10 or can be disposed within a third lumen 34 extending through the length of the catheter 10. A piezoelectric transducer 36 is embedded in or near the distal end 28 of the electrode 24.

[0023] FIG. 2A illustrates a schematic diagram of a system in accordance with the present invention. The system 50 includes an intravascular probe 52 configured to transmit detectable signals to ensure correct positioning of the intravascular probe 52. The intravascular probe 52 includes an intravascular portion 53, and can be configured to resemble a Seldinger-type wire. The intravascular probe 52 is coupled, preferably detachably to a power source 54. In turn the intravascular probe 52 is also coupled to a computing device 56 capable of receiving signal from the intravascular probe 52. While the probe 52 is shown in FIG. 2, the system also

includes a central venous catheter, as described in FIGS. 1A and 1B. The central venous catheter can be connected to the system in the same way as the intravascular probe 52. The system 50 also includes a standard handheld ultrasound probe 58, or any other suitable ultrasound device known to or conceivable by one of skill in the art. The ultrasound probe 58 is connected to the computing device 56, which is also capable of receiving signal from the ultrasound probe 58. The computing device 56 is further configured to overlay transmission from the intravascular probe 52 onto a B-mode ultrasound image 60 obtained using the ultrasound probe 58. The computing device 56 can include synchronization circuitry and software in order to implement the display of the information from the ultrasound probe 58 and the intravascular probe 52. Alternately, the computing device 56 can be wirelessly or wire networked to other computing devices capable of processing this information, such as a server. The computing device 56 can therefore take any form known to or conceivable by one of skill in the art as suitable for this purpose, such as but not limited to a PC, tablet computing device, or smartphone. The synchronization circuitry and software can take the form of a non-transitory computer readable medium.

[0024] FIG. 2B illustrates a distal end 62 of the intravascular probe 52. The distal end of the intravascular probe 52 includes an electrode 64, a piezoelectric transducer 66, and a nitinol wrapping 68 disposed around the electrode 64 and the piezoelectric transducer 66. As noted above, the distal end of the intravascular probe is inserted into the vasculature of the patient, and is detected by the ultrasound probe.

[0025] FIG. 3A illustrates a schematic diagram of a guide wire for a system for ultrasound imaging for placement of a central venous catheter, according to an embodiment of the present invention. As illustrated in FIG. 3A, a system for ultrasound imaging for placement of a central venous catheter 100, includes a guidewire 102. The guide wire 102 is configured to be threaded into the vasculature of a patient, ahead of placement of a central venous or other catheter. The guide wire 102 can take any form known to one of skill in the art. However, preferably the guide wire takes the form of a helically wrapped, shape memory metal, such as nitinol. The guide wire 102 is coupled to a detachable coupling 104. The detachable coupling 104 connects the guide wire 102 to a power/circuitry box 106. When the guide wire 102 is connected to the power/circuitry box 106, the guide wire 102 acts as a transmission ultrasonography probe. While FIG. 3A illustrates a detachable coupling 104 to couple the guide wire 102 to the power/circuitry box 106, the guide wire 102 could be coupled directly to the power/circuitry box 106 with an adapter, or any other mode of attachment known to or conceivable by one of skill in the art. The guide wire 102 can also include a "j" tip or any other suitable distal terminus known to or conceivable by one of skill in the art.

[0026] FIG. 3B illustrates a sectional view of a portion of a guide wire of FIG. 3B, according to an embodiment of the present invention. As illustrated in FIG. 3B, a piezoelectric transducer assembly 110 is positioned just proximal to the distal end of the guide wire 102, i.e. just proximal of the "j" tip. The piezoelectric transducer assembly includes a piezoelectric transducer and two insulated electrodes. As illustrated in FIG. 3B the helical coils 112 of the guide wire 102 surround the piezoelectric transducer assembly 110. It should be noted that when the guide wire 102 is coupled to the power/circuit box 106 it serves as a transmission ultrasonog-

raphy probe, and when it is not connected the guide wire 102 acts passively as a fully functional guide wire.

[0027] FIG. 4A illustrates a schematic diagram of a stylet for a system for ultrasound imaging for placement of a central venous catheter, according to an embodiment of the present invention. As illustrated in FIG. 4A the system 200 includes a stylet 202, a detachable coupling 204, and a power/circuit box 206. The detachable coupling 204 and the power/circuit box 206 can be separate from those described with respect to FIG. 3A, or the same detachable coupling 204 and power/circuit box 206 can be used with both the guide wire and the stylet. When the stylet 202 is connected to the power/circuitry box 206, the stylet 202 acts as a transmission ultrasonography probe. While FIG. 4A illustrates a detachable coupling 204 to couple the stylet 202 to the power/circuitry box 206, the stylet 202 could be coupled directly to the power/circuitry box 206 with an adapter, or any other mode of attachment known to or conceivable by one of skill in the art. The stylet 202 includes an outer diameter that is less than an internal lumen diameter of a catheter used for a central venous catheter, or any other catheter placement with which this system may be used. The stylet 202 is also configured to be sufficiently flexible in order to follow a path of the catheter through the vasculature. The stylet 202 includes a piezoelectric transducer assembly 208 at its distal end and a marking 210 adjacent to its proximal end, in order to have proper stylet 202 placement with respect to a catheter.

[0028] FIG. 4B illustrates a proximal end of the stylet of FIG. 4A being passed through a catheter hub and 4C illustrates a miniature piezoelectric transducer disposed at a tip of the stylet of FIG. 4A, according to an embodiment of the present invention. As illustrated in FIG. 4A, a marking 210 is placed near the proximal end of the stylet. This marking 210 is placed such that alignment of the marking with a rim of the catheter port 212 places the piezoelectric transducer assembly 208 at a distal tip of the catheter 214. FIG. 4C illustrates a piezoelectric transducer assembly 208 of the stylet 202. Similarly to the guide wire, the piezoelectric transducer assembly of the stylet 202 includes a piezoelectric transducer and two insulated electrodes.

[0029] It should be noted that a kit according to an embodiment of the present invention can include both a guide wire and a stylet, as described above, in order to facilitate performance of a central venous catheter, or other catheter, in accordance with the Seldinger technique. Other techniques for catheter placement could also be used, and therefore, the guide wire and stylet could also be used independently of one another. The guide wire and stylet are configured for use with any ultrasound system available for use. An adapter for connection of the guide wire and/or stylet could also be included with a kit, according to an embodiment of the present invention.

[0030] FIG. 5 illustrates a diagram of a proposed clinical use, according to an embodiment of the present invention. As illustrated in FIG. 5 a small infant is positioned on an operating room table. A guide wire and/or a catheter with stylet is placed through a left subclavian vein of the infant. The tip of the guide wire and/or stylet is disposed in a superior vena cava, for central venous catheter placement. Other placement could be contemplated with respect to placement of other types of catheters using the system of the present invention. A commercially available ultrasound system with B-mode

imaging capabilities is used to detect readout from the guide wire and or the stylet. The piezoelectric transducer assembly of the guide wire and stylet described above is configured only to transmit when it hears output from the ultrasound machine. There is no integration of the system of the present invention with the commercially available ultrasound system, and there is no need for tracking or registration of any component therein. The system of the present invention can therefore be used with any available ultrasound machine, making it very versatile.

[0031] FIG. 6 illustrates a schematic diagram of a circuit according to an embodiment of the present invention. As illustrated in FIG. 6, a piezoelectric transducer of the present invention is stimulated in a detection frequency bandwidth by an ultrasound probe. This interaction between the sound waves emitted by the ultrasound probe and the piezoelectric transducer creates an oscillating voltage. A D1 rectifier converts the oscillating voltage into a direct current and charges capacitor C1. U1 and logic gate detect charged capacitor C1 and signal input after stimulation. Voltage controlled switch S1 is closed by U1 output and drives alternating current across the piezoelectric transducer, via the insulated electrodes, described above with respect to the guide wire and stylet. The current across the piezoelectric transducer creates an ultrasound wave. Switch S1 closes when capacitor C1 is discharged under threshold voltage of AND gate, creating a refractory period during which the circuit resets to listen for a next pulse from the ultrasound wand.

Example

[0032] The follow exemplary implementation of an ultrasound probe according to an embodiment of the present invention is included merely as an example, and is not considered to be limiting. Any other implementation known to or conceivable by one of skill in the art could also be used.

[0033] An intravascular transmission ultrasonography probe was custom fabricated, in which a piezoelectric transducer actively emits signal that can be detected by a standard handheld probe, rather than relying solely on reflected acoustic waves to create an image. A miniaturized element was integrated into a flexible catheter that was introduced by vascular sheath into the central veins of an immature pig, as illustrated in FIG. 7A.

[0034] Catheter tip location was noted to blink on B-mode ultrasound with a standard handheld ultrasound probe, as illustrated in FIG. 7B. Tip location along the vessel axis was estimated using the probe freehand and marked with radiopaque beads within 1 cm of its superior/inferior position by digital fluoroscopy, as illustrated in FIG. 7C. With the probe on a fixed passive arm, 3-dimensional tomographic reconstructions demonstrated the catheter tip within 0.5-3 mm of the mid-plane of the ultrasound image, as illustrated in FIG. 7D. An intravascular transmission ultrasonography probe therefore safely allowed accurate and precise localization of relevant venous anatomy in a large animal model.

[0035] The many features and advantages of the invention are apparent from the detailed specification, and thus, it is intended by the appended claims to cover all such features and advantages of the invention which fall within the true spirit and scope of the invention. Further, since numerous modifications and variations will readily occur to those skilled in the art, it is not desired to limit the invention to the exact construction and operation illustrated and described,

and accordingly, all suitable modifications and equivalents may be resorted to, falling within the scope of the invention.

1. A system for intravascular transmission ultrasonography, comprising:

an intravascular probe having a proximal end and a distal end, wherein the intravascular probe is configured to produce ultrasonic energy;

a catheter having a proximal end and a distal end, and also being configured to transmit ultrasonic energy;

a detection probe configured to detect ultrasonic energy from the intravascular probe and the catheter; and

a computing device configured to process and display information from the ultrasound probe.

2. The system of claim 1 wherein the intravascular probe comprises a piezoelectric device.

3. The system of claim 2 wherein the piezoelectric device is disposed at the distal end of the intravascular probe.

4. The system of claim 1 wherein the catheter comprises a piezoelectric device.

5. The system of claim 4 wherein the piezoelectric device is disposed at the distal end of the catheter.

6. The system of claim 1 wherein the detection probe takes the form of a blanket array.

7. The system of claim 1 wherein the detection probe takes the form of a single probe disposed on a robotic arm.

8. The system of claim 1 wherein the computing device comprises a non-transitory computer readable medium.

9. The system of claim 1 wherein the intravascular probe comprises a seldinger-type wire.

10. The system of claim 1 wherein the catheter comprises a central venous catheter.

11. A kit for placement of a catheter comprising:

a guide wire having a proximal end, a distal end, and an elongate length extending therebetween;

a piezoelectric transducer assembly positioned just proximal to a distal end of the guide wire;

a source of power; and

circuitry in electrical communication with the piezoelectric transducer assembly, such that when the piezoelectric transducer assembly detects output from an ultrasound probe, the piezoelectric transducer is trigger to produce an ultrasound wave.

12. A kit for placement of a catheter comprising:

a stylet having a proximal end, a distal end, and an length extending therebetween;

a piezoelectric transducer assembly positioned at a distal end of the stylet;

a source of power; and

circuitry in electrical communication with the piezoelectric transducer assembly, such that when the piezoelectric transducer assembly detects output from an ultrasound probe, the piezoelectric transducer is trigger to produce an ultrasound wave.

13. A kit for placement of a catheter comprising:

a guide wire having a proximal end, a distal end, and an elongate length extending therebetween;

a first piezoelectric transducer assembly positioned just proximal to a distal end of the guide wire;

a stylet having a proximal end, a distal end, and an length extending therebetween;

a second piezoelectric transducer assembly positioned at a distal end of the stylet;

a source of power; and

circuitry in electrical communication with the first and second piezoelectric transducer assemblies, such that when the piezoelectric transducer assembly detects output from an ultrasound probe, the piezoelectric transducer is trigger to produce an ultrasound wave.

* * * * *

专利名称(译)	利用透射超声波检查以使超声引导放置中心静脉导管的装置		
公开(公告)号	US20160192900A1	公开(公告)日	2016-07-07
申请号	US14/916260	申请日	2014-08-01
[标]申请(专利权)人(译)	约翰霍普金斯大学		
申请(专利权)人(译)	约翰·霍普金斯大学		
当前申请(专利权)人(译)	约翰·霍普金斯大学		
[标]发明人	ABDULLAH FIZAN GOLDSTEIN SETH BOCTOR EMAD		
发明人	ABDULLAH, FIZAN GOLDSTEIN, SETH BOCTOR, EMAD		
IPC分类号	A61B8/12 A61B8/08 A61B8/00		
CPC分类号	A61B8/12 A61B8/4218 A61B8/445 A61B8/4483 A61B8/0841		
优先权	61/872903 2013-09-03 US		
外部链接	Espacenet USPTO		

摘要(译)

超声通常使用外部经皮探针进行，该外部经皮探针发射超声能量并测量反射波的定时，从而允许测量流体流动或形成二维图像。临床上，随着超声波穿透组织的深度增加，以及不同组织之间回声 - 生成的相似性，信号的衰减限制了模态。本发明包括一种系统，其中血管内探针主动发射超声波，然后可以通过在线压电换能器检测而无需反射。该信号可以覆盖在传统的B模式或多普勒表示上。此外，本发明包括信号处理系统，其将显示血管解剖结构的实时图形表示，以帮助外科医生或程序放射科医师放置中心静脉导管。

