



(19) **United States**

(12) **Patent Application Publication** (10) **Pub. No.: US 2006/0173337 A1**

Chen et al.

(43) **Pub. Date:**

Aug. 3, 2006

(54) **INTRAVASCULAR ULTRASOUND PROBING DEVICE**

Publication Classification

(51) **Int. Cl.**

A61B 8/06 (2006.01)

(52) **U.S. Cl.** **600/454**

(76) Inventors: **Yu Shih Chen**, Taoyuan City (TW);
Wen Pin Hsieh, Sanwan Township (TW);
Ih Yuan Kuo, Shengang Township (TW);
Pao Hung Lin, Changhua City (TW)

(57) **ABSTRACT**

The present invention provides an intravascular ultrasound probing device using Doppler effect. The intravascular ultrasound probing device comprises a first tube, a first ultrasound probe head positioned in the first tube, a second ultrasound probe head positioned in the first tube and an separating member positioned between the first ultrasound probe head and the second ultrasound probe head. Preferably, the first ultrasound probe head and the second ultrasound probe head are made of lead zirconate titanate (PZT), and can generate an ultrasound with a frequency between 1 MHz and 100 MHz. The first ultrasound probe head can measure the flow of the blood in a vessel, and the second ultrasound probe head can capture the image of the wall of the vessel. The separating member is preferably made of polymer for absorbing undesired reflection wave.

Correspondence Address:
VOLENTINE FRANCOS, P.L.L.C.
Suite 150
12200 Sunrise Valley Drive
Reston, VA 20191 (US)

(21) Appl. No.: **11/155,612**

(22) Filed: **Jun. 20, 2005**

(30) **Foreign Application Priority Data**

Dec. 29, 2004 (TW)..... 093141103

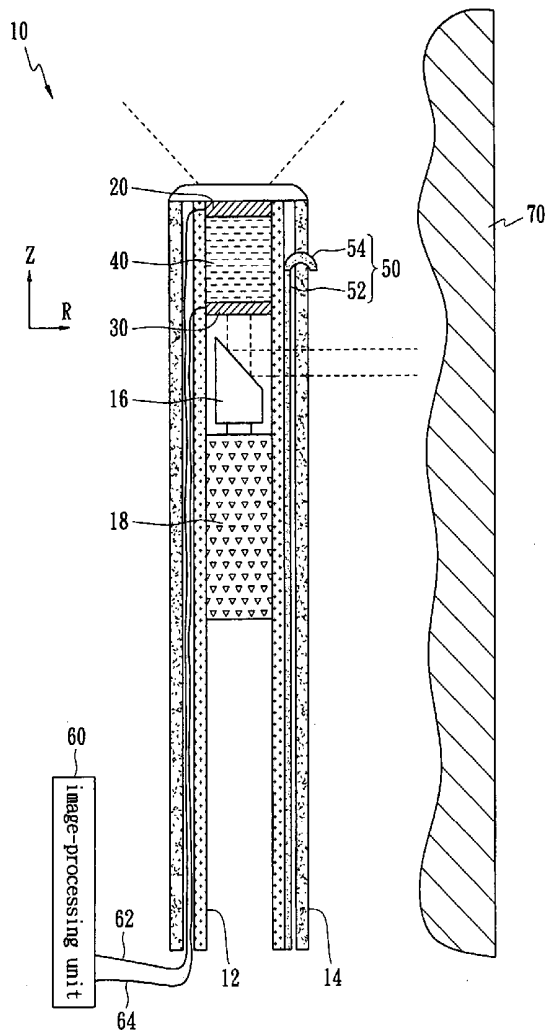

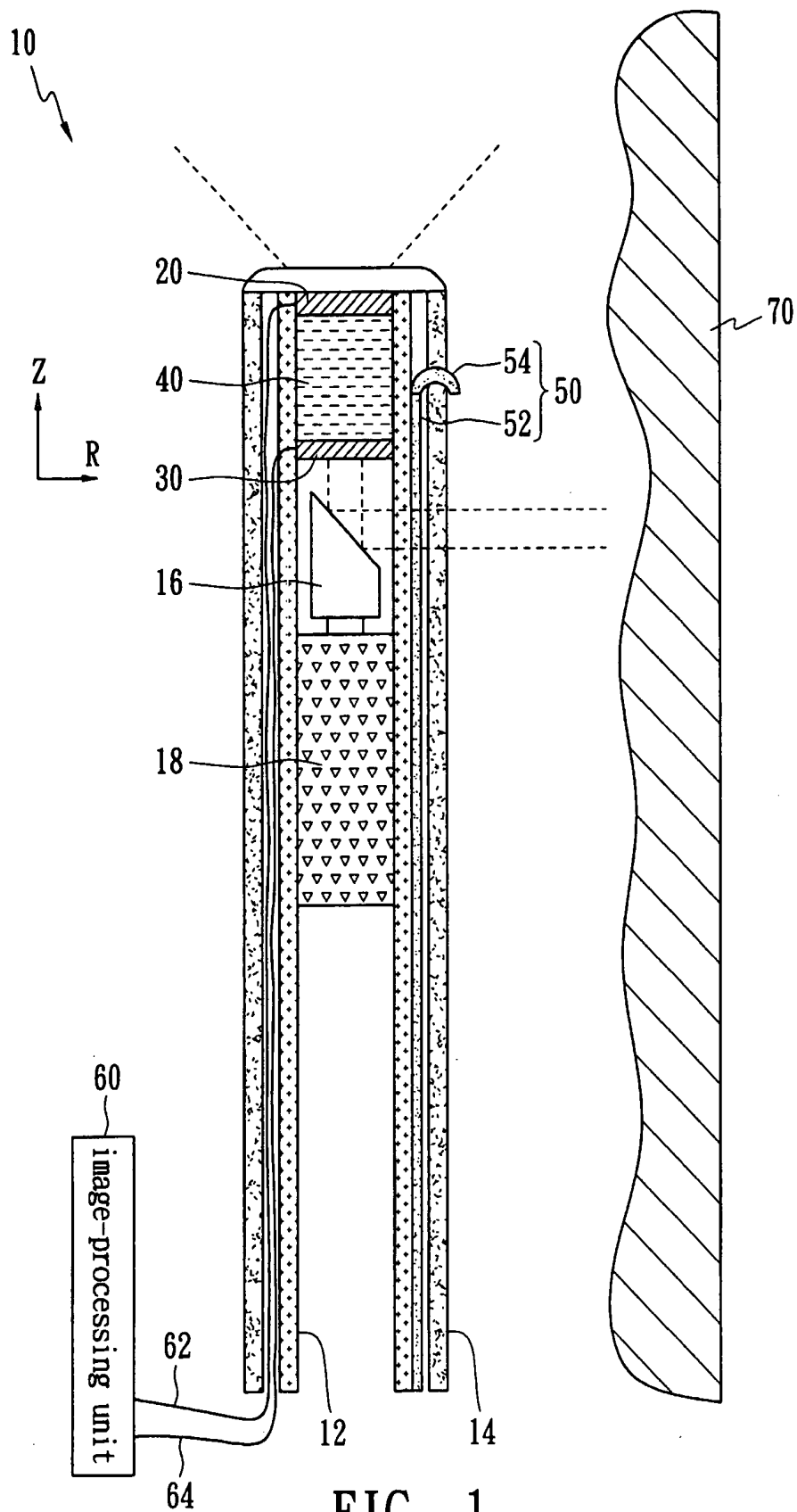

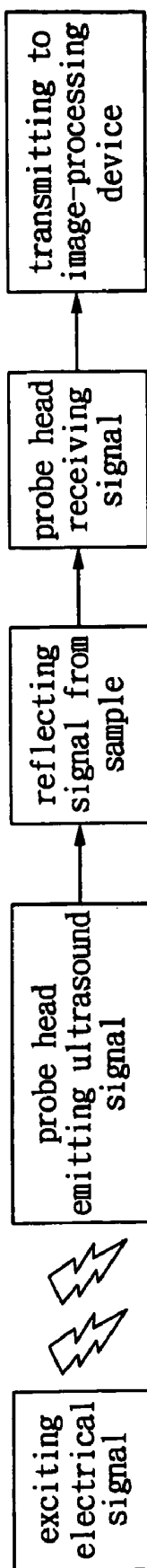

FIG. 2

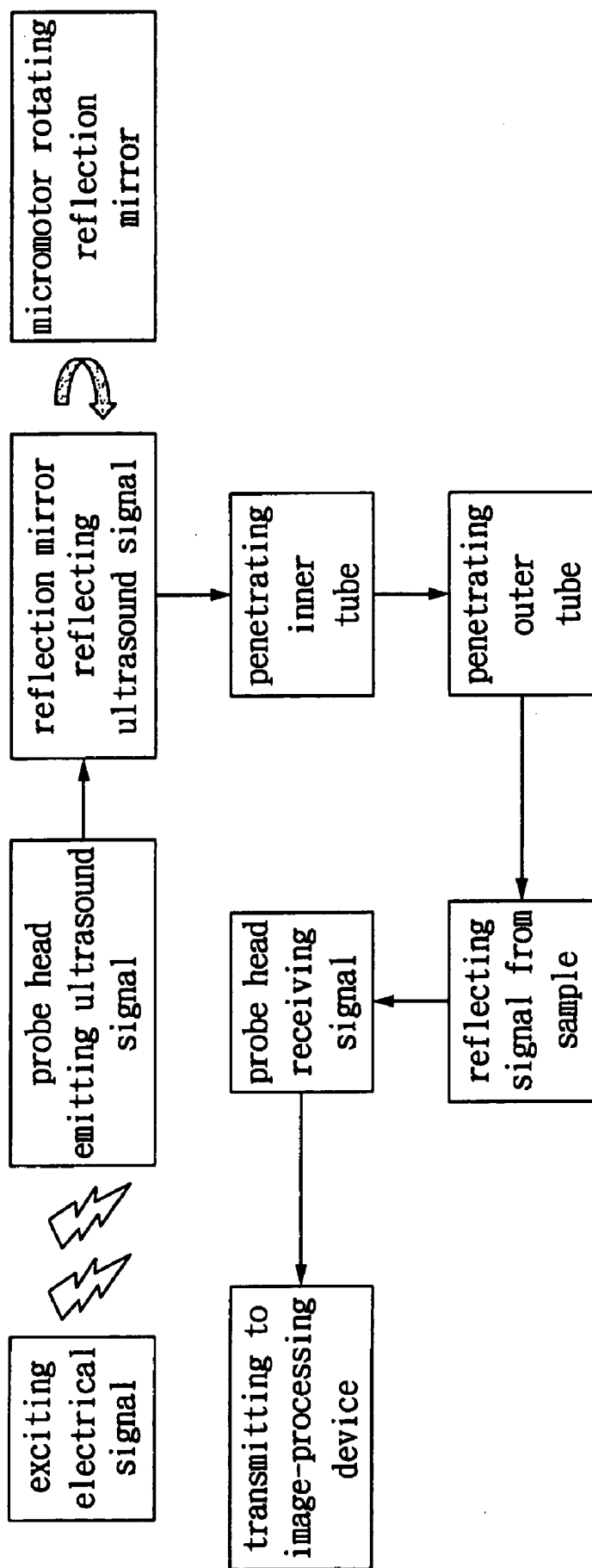

FIG. 3

INTRAVASCULAR ULTRASOUND PROBING DEVICE

BACKGROUND OF THE INVENTION

[0001] (A) Field of the Invention

[0002] The present invention relates to an intravascular ultrasound probing device, and more particularly, to an intravascular ultrasound probing device with Doppler effect.

[0003] (B) Description of the Related Art

[0004] Treatment of the intravascular diseases depends primarily on surgical operations. During the surgical operation, it is more important that instruments can help doctors to diagnose correctly. Therefore, an intravascular ultrasound system (IVUS) is widely used in the detecting apparatus for the intravascular disease operation.

[0005] U.S. Pat. No. 5,582,171 discloses an intravascular Doppler interference imaging system, which can acquire images around the wall of the blood vessel to assist in diagnosing the atherosclerosis, thrombus and intravascular obstruction. However, the intravascular Doppler interference imaging system disclosed in U.S. Pat. No. 5,582,171 cannot provide flow information of blood in the blood vessel, and therefore physicians cannot diagnose precisely.

SUMMARY OF THE INVENTION

[0006] The objective of the present invention is to provide an intravascular ultrasound probing device with Doppler effect.

[0007] In order to achieve the above-mentioned objective and avoid the problems of the prior skills, the present invention provides an intravascular ultrasound probing device with Doppler effect. The intravascular ultrasound probing device comprises a first tube, a first ultrasound probe head positioned in the first tube, a second ultrasound probe head positioned in the first tube and an separating member positioned between the first ultrasound probe head and the second ultrasound probe head. Preferably, the first ultrasound probe head and the second ultrasound probe head are made of lead zirconate titanate (PZT), and can generate an ultrasound with a frequency between 1 MHz and 100 MHz. The first ultrasound probe head can measure the flow of the blood in a vessel, and the second ultrasound probe head can capture the image of the wall of the vessel. The separating member is preferably made of polymer for absorbing undesired reflection wave.

[0008] The present intravascular ultrasound probing device uses piezoelectric material to make the probe head, which is used not only to generate an ultrasound for probing, but also to receive the ultrasound reflected by the sample to be measured. In other words, the present intravascular ultrasound probing device uses the same element as a signal generator and signal receiver. Consequently, it is possible to integrate two probe heads inside a single tube to probe both the blood flow and the image of the wall of the blood vessel at the same time. The prior art uses the laser beam as the probing signal, which can only penetrate the organization for about 2 to 3 mm and the intensity of the probing signal attenuates dramatically. On the contrary, the present invention uses the ultrasound as the probing signal, which can

penetrate the organization for about several centimeters and the intensity of the probing signal only attenuates slightly on penetrating the tube.

BRIEF DESCRIPTION OF THE DRAWINGS

[0009] The objectives and advantages of the present invention will become apparent upon reading the following description and upon reference to the accompanying drawings in which:

[0010] **FIG. 1** is a cross-sectional view of an intravascular ultrasound probing device according to the present invention; and

[0011] **FIG. 2** and **FIG. 3** are a signal flow diagram of the intravascular ultrasound probing device according to the present invention.

DETAILED DESCRIPTION OF THE INVENTION

[0012] **FIG. 1** is a cross-sectional view of an intravascular ultrasound probing device **10** according to the present invention. The intravascular ultrasound probing device **10** comprises a first tube **12**, a first ultrasound probe head **20** positioned in the first tube **12**, a second ultrasound probe head **30** positioned in the first tube **12** and a separating member **40** positioned between the first ultrasound probe head **20** and the second ultrasound probe head **30**. Preferably, the first ultrasound probe head **20** and the second ultrasound probe head **30** are made of piezoelectric material such as lead zirconate titanate (PZT), and can generate an ultrasound with a frequency between 1 MHz and 100 MHz. The separating member **40** is preferably made of polymer to absorb unwanted reflecting ultrasound.

[0013] The intravascular ultrasound probing device **10** can further comprise a reflection mirror **16** positioned in the first tube **12**, a driver **18** positioned in the first tube **12**, a second tube **14**, a guiding member **50** and an image-processing unit **60** (e.g. image processing circuit). The guiding member **50** comprises a body **52** positioned between the first tube **12** and the second tube **14**, and barb **54** connected to the body **52** and protruding the second tube **14**. When the intravascular ultrasound probing device **10** goes forward in a blood vessel of a human body and meets blood vessel branches, an operator can guide the intravascular ultrasound probing device **10** in the blood vessel via the guiding member **50** to any one of blood vessel branches.

[0014] The image-processing unit **60** is electrically connected to the first ultrasound probe head **20** and the second ultrasound probe head **30** via signal wires **62** and **64**, respectively. The first tube **12** is positioned inside the second tube **14**, i.e., the first tube **12** is an inner tube, while the second tube **14** is an outer tube, and a space between the inner tube and the outer tube is available for setting the signal wires **62** and **64**.

[0015] The driver **18** can be a micromotor for rotating the reflection mirror **16** in order to guide the ultrasound from the second ultrasound probe head **30** to the wall of the blood vessel **70**. In other words, the reflection mirror **16** will reflect the ultrasound from the second ultrasound probe head **30** from Z-axis to R-axis, while the driver **18** will rotate the reflection mirror **16** to allow the ultrasound from the second ultrasound probe head **30** to reach the wall of the blood vessel **70** at any angle.

[0016] FIG. 2 and FIG. 3 are a signal flow diagram of the intravascular ultrasound probing device 10 according to the present invention. As shown in FIG. 2, an exciting electrical signal drives the first ultrasound probe head 20, made of PZT, to emit an ultrasound in the positive direction of Z-axis, which can penetrate a sample to be measured (e.g. blood in the blood vessel 70) to a predetermined depth (about several centimeters), and then reflected by the sample to the first ultrasound probe head 20. The first ultrasound probe head 20 receives the ultrasound reflected by the blood, and is then transmitted to the image-processing unit 60 via the signal wire 62. The image-processing unit 60 will predict the blood flow in the blood vessel 70 according to the ultrasound reflected by the blood in the blood vessel 70 to diagnose whether or not an intravascular obstruction occurs.

[0017] As shown in FIG. 3, an exciting electrical signal drives the second ultrasound probe head 30, also made of PZT, to emit an ultrasound at the negative direction of Z-axis, which is reflected by the reflection mirror 16 to R-axis to reach the wall of the blood vessel 70 after penetrating the first tube 12 and the second tube 14. The ultrasound can penetrate the wall of the blood vessel 70 to a predetermined depth and can then be reflected to the reflection mirror 16, which will further reflect the ultrasound to the second ultrasound probe head 30. The second ultrasound probe head 30 receives the ultrasound from the wall of the blood vessel 70 via the reflection mirror 16, and transmits the reflected ultrasound to the image-processing unit 60 via the signal wire 64. The image-processing unit 60 picks up the image of the wall according to the reflected ultrasound from the wall of the blood vessel 70. The driver 18 can rotate the reflection mirror 16 360° to pick up all images of the blood vessel 70.

[0018] Compared to prior art, the intravascular ultrasound probing device 10 according to the present invention possesses advantages listed in the table below:

	Prior art	Present invention
Probe type	Optical	Ultrasound
Penetrating depth	Shallow: 2 to 3 mm	Deep: several centimeters
Operating frequency	~	1 MHz to 100 MHz
Reference end	Required	Not required
Exciting source	In the instrument	In the tube
Receiving end	In the instrument	In the tube
Efficiency	Attenuate dramatically	Attenuate on penetrating the tube only

[0019] As shown in the table above, the present intravascular ultrasound probing device 10 uses the probe head made of piezoelectric material, which is used not only to generate an ultrasound for probing, but also to receive the ultrasound reflected by the sample to be measured. In other words, the present intravascular ultrasound probing device 10 uses the same element as a signal generator and signal receiver. Consequently, it is possible to integrate two probe heads inside a single tube to probe both the blood flow and the image of the wall of the blood vessel at the same time. The prior art uses the laser beam as the probing signal, which can only penetrate the organization about 2 to 3 mm and the intensity of the probing signal attenuates dramatically. On the contrary, the present invention uses the ultrasound as the probing signal, which can penetrate the organization about several centimeters and the intensity of the probing signal only attenuates slightly on penetrating the tube.

[0020] The above-described embodiments of the present invention are intended to be illustrative only. Numerous alternative embodiments may be devised by those skilled in the art without departing from the scope of the following claims.

What is claimed is:

1. An intravascular ultrasound probing device, comprising:
 - a first tube;
 - a first ultrasound probe head positioned in the first tube for measuring the flow of the blood in a vessel;
 - a second ultrasound probe head positioned in the first tube for capturing the image of the wall of the vessel; and
 - a separating member positioned between the first ultrasound probe head and the second ultrasound probe head.
2. The intravascular ultrasound probing device of claim 1, wherein the first ultrasound probe head is made of lead zirconate titanate, and can generate an ultrasound with a frequency between 1 MHz and 100 MHz.
3. The intravascular ultrasound probing device of claim 1, wherein the second ultrasound probe head is made of lead zirconate titanate, and can generate an ultrasound with a frequency between 1 MHz and 100 MHz.
4. The intravascular ultrasound probing device of claim 1, further comprising:
 - a reflection mirror positioned in the first tube for guiding an ultrasound from the second ultrasound probe head to the wall of the vessel; and
 - a driver positioned in the first tube for rotating the reflection mirror.
5. The intravascular ultrasound probing device of claim 4, wherein the driver is a micromotor.
6. The intravascular ultrasound probing device of claim 1, further comprising a second tube, wherein the first tube is positioned in the second tube.
7. The intravascular ultrasound probing device of claim 6, further comprising a plurality of signal wires positioned between the first tube and the second tube for transmitting signals received by the first ultrasound probe head and the second ultrasound probe head.
8. The intravascular ultrasound probing device of claim 6, further comprising a guiding member positioned between the first tube and the second tube.
9. The intravascular ultrasound probing device of claim 8, wherein the guiding member comprises:
 - a body positioned between the first tube and the second tube; and
 - a barb connected to the body and protruding the second tube.
10. The intravascular ultrasound probing device of claim 1, further comprising an image-processing unit electrically connected to the first ultrasound probe head and the second ultrasound probe head.
11. The intravascular ultrasound probing device of claim 1, wherein the separating member is made of polymer.

专利名称(译)	血管内超声探测装置		
公开(公告)号	US20060173337A1	公开(公告)日	2006-08-03
申请号	US11/155612	申请日	2005-06-20
[标]申请(专利权)人(译)	振宇小号 谢文P KUO IHÿ LIN PAO ^ h		
申请(专利权)人(译)	振宇小号 谢文P KUO IHÿ LIN PAO ^ h		
当前申请(专利权)人(译)	工业技术研究院		
[标]发明人	CHEN YU SHIH HSIEH WEN PIN KUO IH YUAN LIN PAO HUNG		
发明人	CHEN, YU SHIH HSIEH, WEN PIN KUO, IH YUAN LIN, PAO HUNG		
IPC分类号	A61B8/06		
CPC分类号	A61B8/06 A61B8/12 A61B8/4461		
优先权	093141103 2004-12-29 TW		
外部链接	Espacenet USPTO		

摘要(译)

本发明提供一种使用多普勒效应的血管内超声探测装置。血管内超声探测装置包括第一管，位于第一管中的第一超声探头，位于第一管中的第二超声探头和位于第一超声探头和第二超声探头之间的分离构件。优选地，第一超声探头和第二超声探头由锆钛酸铅 (PZT) 制成，并且可以产生频率在1MHz和100MHz之间的超声波。第一超声探头可以测量血管中血液的流量，第二超声探头可以捕获血管壁的图像。分离构件优选地由聚合物制成，用于吸收不希望的反射波。

