



US009125589B2

(12) **United States Patent**  
**Sørnes**

(10) **Patent No.:** **US 9,125,589 B2**  
(45) **Date of Patent:** **Sep. 8, 2015**

(54) **SYSTEM AND METHOD FOR TISSUE CHARACTERIZATION USING ULTRASOUND IMAGING**

(75) Inventor: **Anders Rasmus Sørnes**, Oslo (NO)

(73) Assignee: **General Electric Company**,  
Schenectady, NY (US)

(\*) Notice: Subject to any disclaimer, the term of this patent is extended or adjusted under 35 U.S.C. 154(b) by 1622 days.

5,549,111 A *	8/1996	Wright et al. ....	600/443
5,606,971 A *	3/1997	Sarvazyan .....	600/438
5,810,731 A	9/1998	Sarvazyan et al.	
6,135,960 A	10/2000	Holmberg	
6,385,474 B1 *	5/2002	Rather et al. ....	600/407
6,702,745 B1	3/2004	Smythe	
6,876,928 B2 *	4/2005	Van Riel et al. ....	702/2
7,175,599 B2	2/2007	Hynynen et al.	
7,252,004 B2	8/2007	Fink et al.	
7,670,293 B2 *	3/2010	Dubberstein et al. ....	600/453
2004/0064050 A1 *	4/2004	Liu et al. ....	600/457
2004/0167403 A1 *	8/2004	Nightingale et al. ....	600/437
2004/0215075 A1 *	10/2004	Zagzebski et al. ....	600/442

FOREIGN PATENT DOCUMENTS

(21) Appl. No.: **11/801,322**

WO WO 2007021185 A1 \* 2/2007

(22) Filed: **May 9, 2007**

\* cited by examiner

(65) **Prior Publication Data**

US 2008/0281196 A1 Nov. 13, 2008

*Primary Examiner* — Rajeev Siripurapu

(74) *Attorney, Agent, or Firm* — Dean D. Small; The Small Patent Law Group, LLC

(51) **Int. Cl.**

**A61B 8/00** (2006.01)  
**A61B 8/08** (2006.01)  
**A61B 5/02** (2006.01)

(57) **ABSTRACT**

(52) **U.S. Cl.**

CPC ..... **A61B 8/08** (2013.01); **A61B 5/02007** (2013.01); **A61B 8/485** (2013.01)

An ultrasound system comprises an ultrasound probe for transmitting transmit beams and receiving receive beams. A processor controls the ultrasound probe to direct the transmit beams in a first direction to acquire a first incidence frame of data and a second direction to acquire a second incidence frame of data, wherein the first and second directions are different with respect to each other. A tissue characterization module compares the normal and oblique incidence frames of data to determine at least one property parameter of a scanned medium based on amplitude differences between the receive beams.

(58) **Field of Classification Search**

CPC ..... **A61B 8/085**; **A61B 5/02007**  
USPC ..... **600/443, 437, 438, 447, 459**  
See application file for complete search history.

(56) **References Cited**

U.S. PATENT DOCUMENTS

4,858,201 A *	8/1989	Goins et al. ....	367/75
5,197,475 A *	3/1993	Antich et al. ....	600/437

**31 Claims, 5 Drawing Sheets**

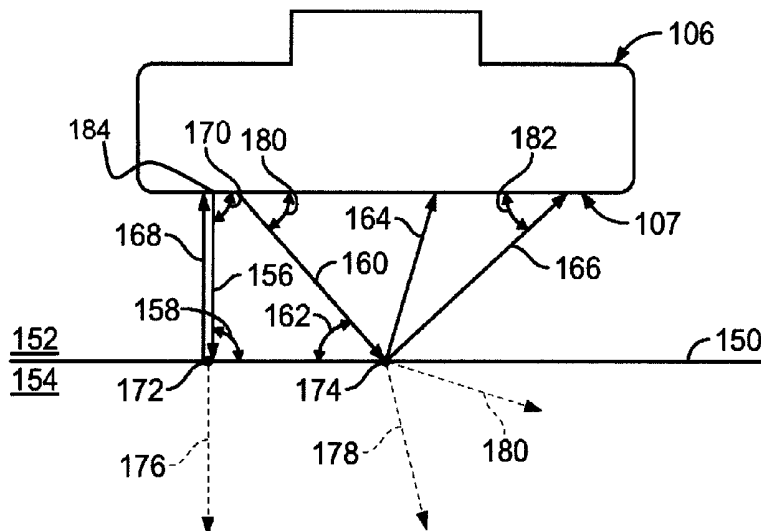

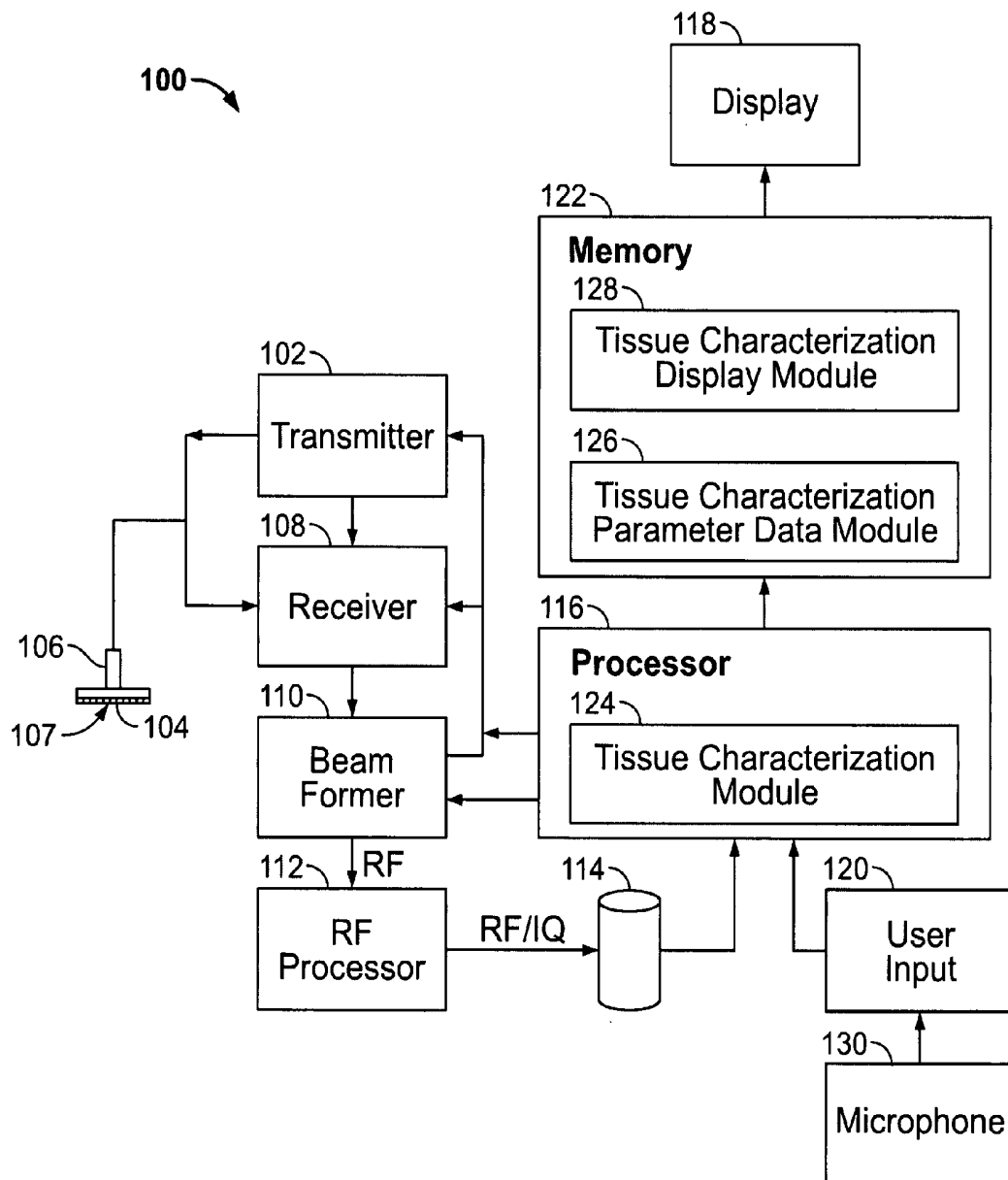

FIG. 1

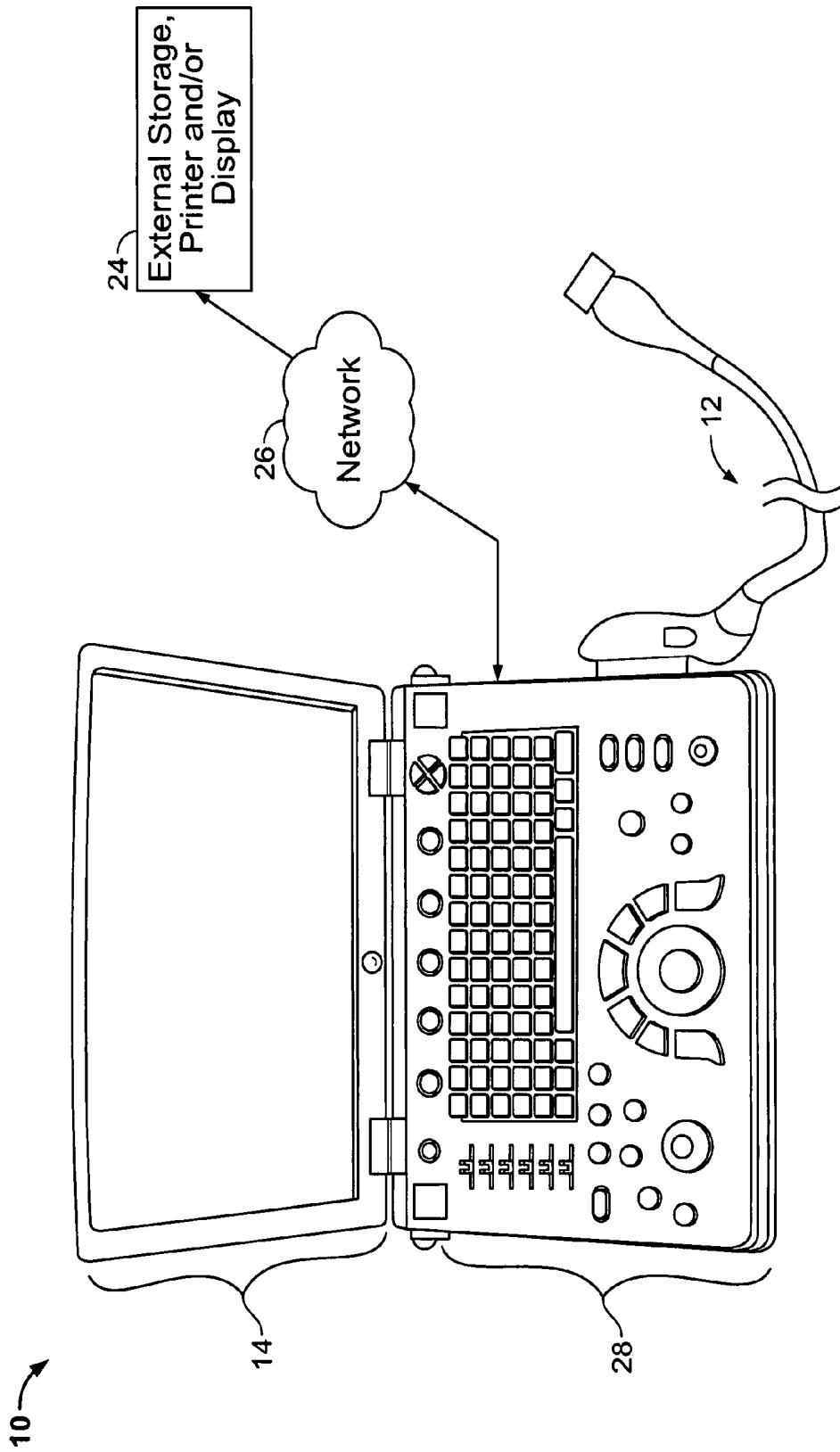

FIG. 2

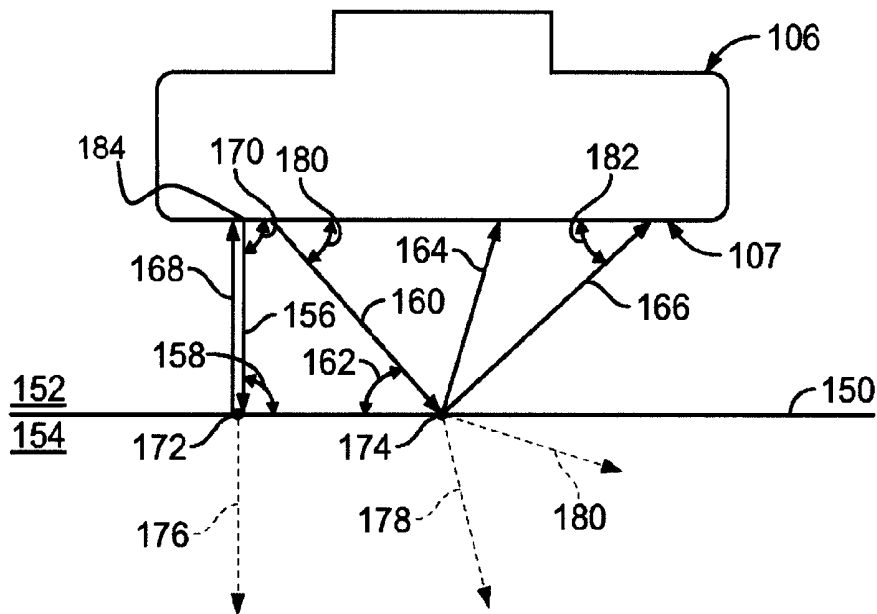

FIG. 3

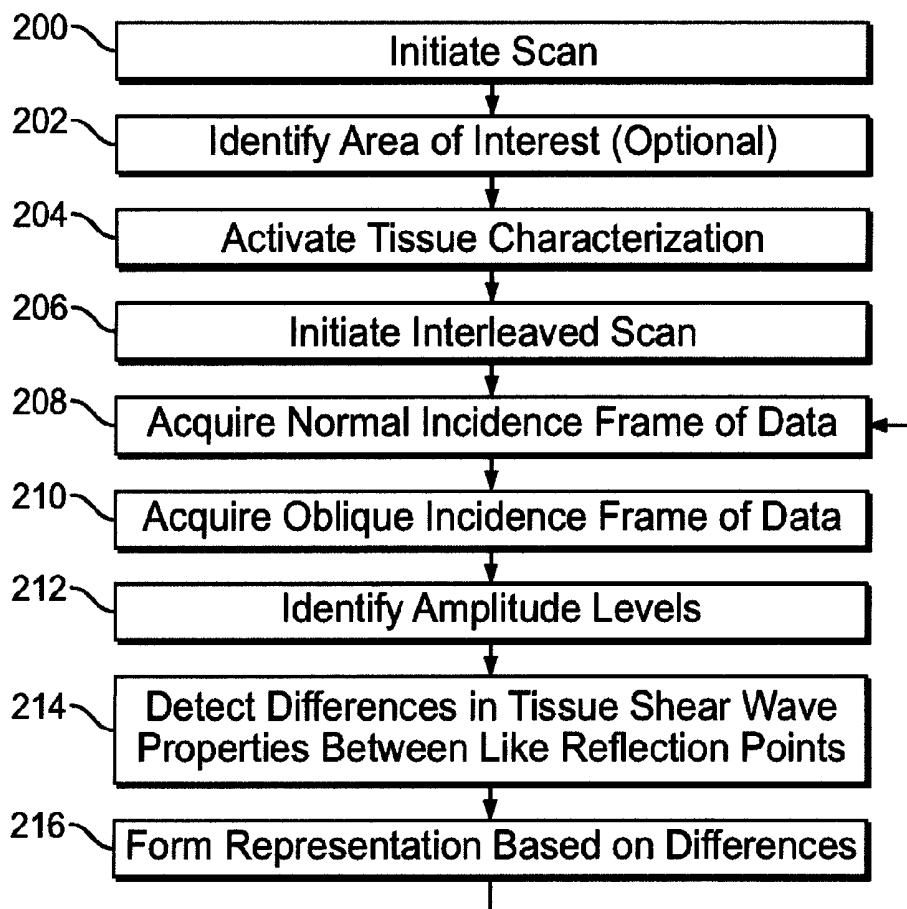

FIG. 4

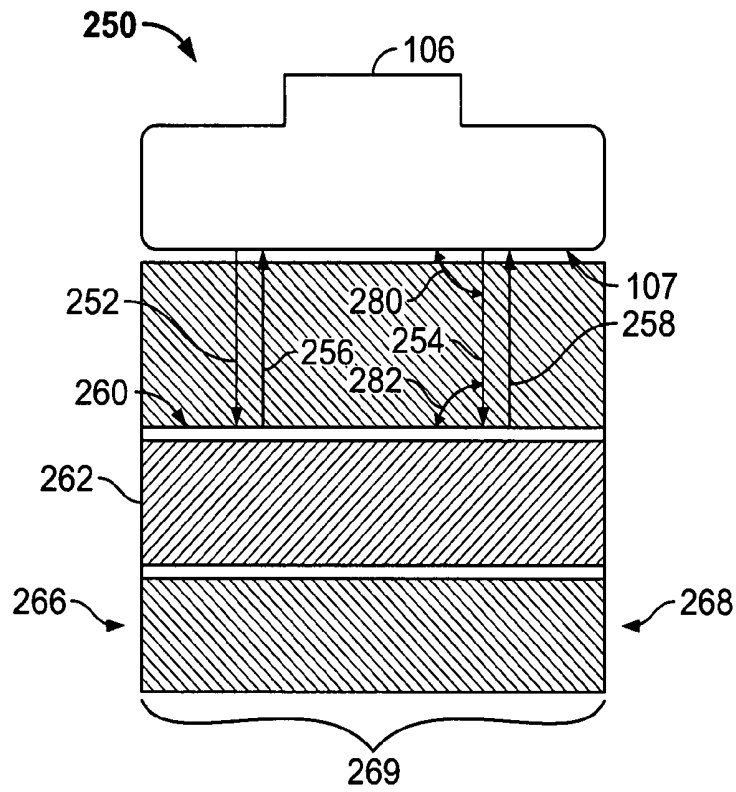

FIG. 5

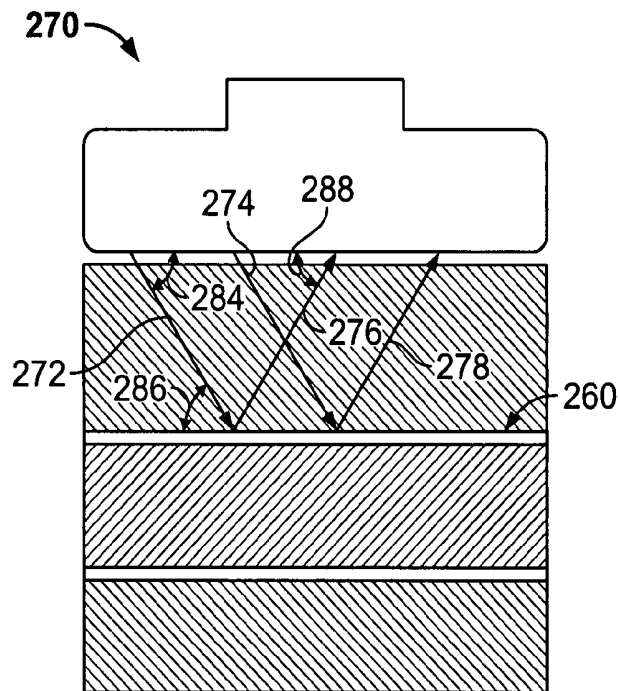

FIG. 6

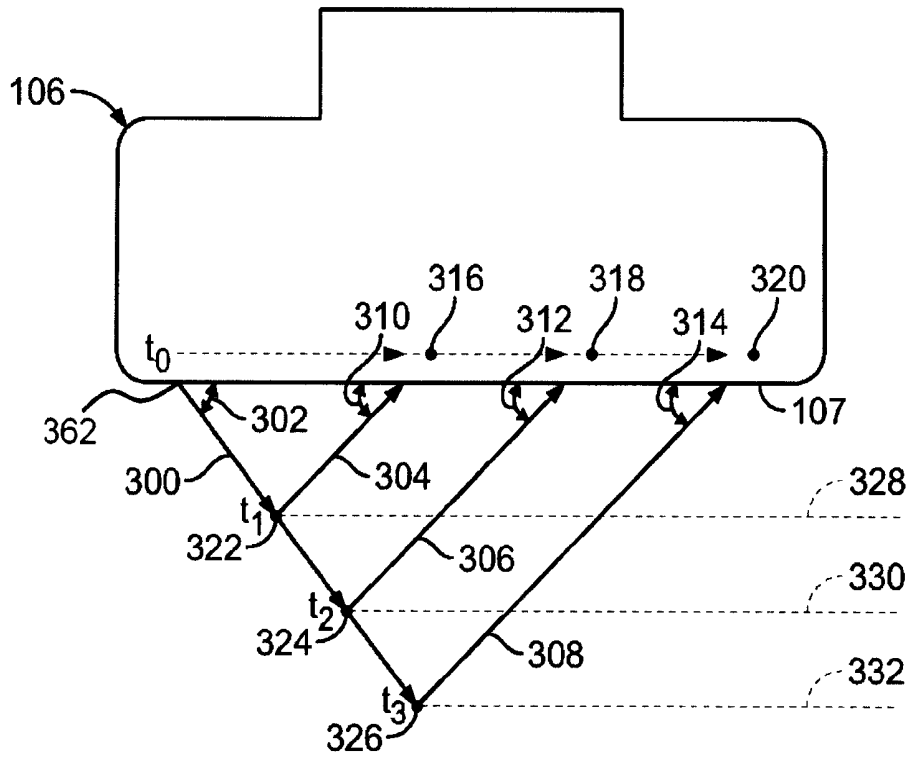

FIG. 7

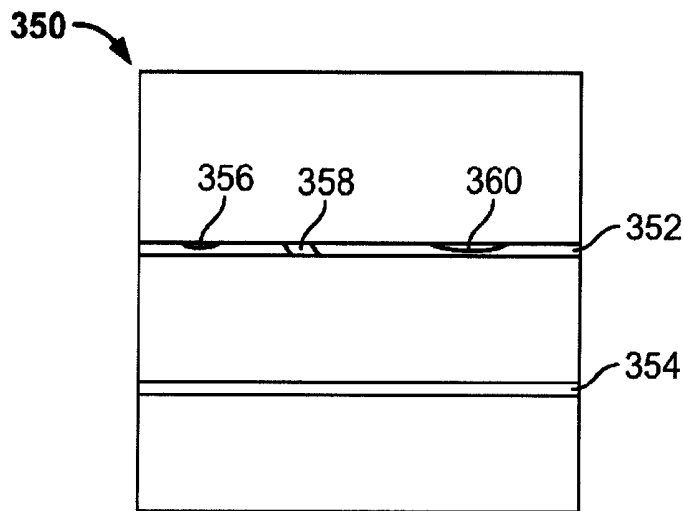

FIG. 8

## SYSTEM AND METHOD FOR TISSUE CHARACTERIZATION USING ULTRASOUND IMAGING

### BACKGROUND OF THE INVENTION

This invention relates generally to ultrasound imaging, and more particularly to detecting and indicating differences in tissue within an ultrasound image.

With current ultrasound imaging it is difficult to detect tissue properties such as tissue elasticity, stiffness, morphology or type. Tissue elasticity varies, for example, between different types of tissue, such as hard and soft plaque within the carotid artery. Also, a tumor or other mass will have tissue elasticity that is different compared to surrounding tissues. Having the ability to detect the elasticity or stiffness differences would improve the ability to detect dangerous plaque as well as other pathologies.

Shear modulus is a parameter related to the hardness or elasticity of a material or tissue. The shear modulus of various soft tissues ranges over several orders of magnitude. Previous methods for imaging elastic properties with ultrasound, such as radiation force ultrasound, rely on high amplitude, low frequency acoustic radiation fields or external vibration sources to generate shear waves in the tissue. Examples of imaging techniques are tissue velocity imaging (TVI) and strain imaging. Other techniques use multiple ultrasound transducers, thereby increasing the cost and complexity of a procedure.

Therefore, a need exists for detecting elasticity properties of tissues and indicating elasticity differences using standard ultrasound imaging with a single ultrasound probe.

### BRIEF DESCRIPTION OF THE INVENTION

In one embodiment, an ultrasound system comprises an ultrasound probe for transmitting transmit beams and receiving receive beams. A processor controls the ultrasound probe to direct the transmit beams in a first direction to acquire a first incidence frame of data and a second direction to acquire an second incidence frame of data, wherein the first and second directions are different with respect to each other. A tissue characterization module compares the first and second incidence frames of data to determine at least one property parameter of a scanned medium based on amplitude differences between the receive beams.

In another embodiment, a method for detecting differences in tissue comprises acquiring a normal incidence frame of data by transmitting transmit beams in a first direction that is approximately 90 degrees with respect to a probe face. An oblique incidence frame of data is acquired by transmitting transmit beams in a second direction that is different than the first direction. The second direction forms an oblique angle with respect to the probe face. Amplitude magnitude differences are determined between receive beams of the normal and oblique incidence frame of data, and a representation is displayed based on amplitude magnitude differences.

In yet another embodiment, a method for detecting differences in tissue comprises acquiring a normal incidence frame of data by transmitting transmit beams in a first direction that is approximately 90 degrees with respect to a probe face. An oblique incidence frame of data is acquired by transmitting transmit beams in a second direction that is different than the first direction. The second direction forms an oblique angle with respect to the probe face. An image is displayed based on at least the normal incidence frame, and a parametric overlay

is displayed on the image. The parametric overlay is based on amplitude differences between the normal and oblique incidence frames of data.

### BRIEF DESCRIPTION OF THE DRAWINGS

FIG. 1 illustrates a block diagram of an ultrasound system formed in accordance with an embodiment of the present invention.

FIG. 2 illustrates a miniaturized ultrasound system having a probe configured to acquire ultrasonic data in accordance with an embodiment of the present invention.

FIG. 3 illustrates an example of generating pressure waves and/or shear waves using diagnostic ultrasound scanning in accordance with an embodiment of the present invention.

FIG. 4 illustrates a method for detecting tissue elasticity characteristics using diagnostic ultrasound scanning in accordance with an embodiment of the present invention.

FIG. 5 illustrates a first scanning sequence used to acquire a normal incidence frame of data in accordance with an embodiment of the present invention.

FIG. 6 illustrates a second scanning sequence used to acquire an oblique incidence frame of data in accordance with an embodiment of the present invention.

FIG. 7 illustrates another example of transmitting and receiving beams to acquire an oblique incidence frame of data in accordance with an embodiment of the present invention.

FIG. 8 illustrates a parametric overlay that may be displayed over a corresponding B-mode image to display changes in stiffness in tissues in accordance with an embodiment of the present invention.

### DETAILED DESCRIPTION OF THE INVENTION

The foregoing summary, as well as the following detailed description of certain embodiments of the present invention, will be better understood when read in conjunction with the appended drawings. To the extent that the figures illustrate diagrams of the functional blocks of various embodiments, the functional blocks are not necessarily indicative of the division between hardware circuitry. Thus, for example, one or more of the functional blocks (e.g., processors or memories) may be implemented in a single piece of hardware (e.g., a general purpose signal processor or random access memory, hard disk, or the like). Similarly, the programs may be stand alone programs, may be incorporated as subroutines in an operating system, may be functions in an installed software package, and the like. It should be understood that the various embodiments are not limited to the arrangements and instrumentality shown in the drawings.

FIG. 1 illustrates a block diagram of an ultrasound system 100. The ultrasound system 100 includes a transmitter 102 that drives transducer elements 104 within a probe 106 to emit pulsed ultrasonic signals into a body. The probe 106 has a probe face 107 typically configured to rest on the skin of a patient or outer surface of the subject being scanned. The probe 106 may be a linear probe or other probe able to perform interleaved scanning as discussed below. The ultrasonic signals or transmit beams are back-scattered from structures in the body, like blood cells or muscular tissue, to produce echoes or receive beams that return to the transducer elements 104. The returning echoes are converted by the transducer elements 104 back to electrical energy that is received by a receiver 108. The received signals are passed through a beamformer 110 that performs beamforming (combining the transducer element signals to perform steering and focusing of the beam) and outputs an RF signal. The RF signal then passes

through an RF processor **112**. Alternatively, the RF processor **112** may include a complex demodulator (not shown) that demodulates the RF signal to form IQ data pairs representative of the echo signals. The RF or IQ signal data may then be routed directly to an RF/IQ buffer **114** for temporary storage.

A user input **120** may be used to control operation of the ultrasound system **100**, including, to control the input of patient data, scan parameters, select tissue characterization to detect elasticity properties during a current scan, select and/or change how the tissue characterization is displayed, and may also include using voice commands provided via a microphone **130**. Other various embodiments such as a set of user controls may be configured for controlling the ultrasound system **100** and may be provided, for example, as part of a touch screen or panel, and as manual inputs, such as user operable switches, buttons, and the like. The set of user controls may be manually operable or voice operated.

The ultrasound system **100** also includes a processor **116** to process the acquired ultrasound information (i.e., RF signal data or IQ data pairs) and prepare frames of ultrasound information for display on display **118**. The processor **116** is adapted to perform one or more processing operations according to a plurality of selectable ultrasound modalities on the acquired ultrasound information. Acquired ultrasound information may be processed in real-time during a scanning session as the echo signals are received.

A tissue characterization module **124**, a tissue characterization parameter data module **126** and a tissue characterization display module **128** may be used to detect property parameter differences such as stiffness that are present within tissues currently being scanned and to indicate the differences to the operator. The modules **124**, **126** and **128** may be implemented in hardware or software, or a combination thereof. Tissue differences may be detected within a predetermined area based on at least the size of the linear probe **106**, the depth of the image, and the like. Optionally, the operator may select a subset of the image by defining and/or modifying a region of interest (ROI) within which tissue characterization is accomplished. Optionally, the operator may input a specific depth(s) or point(s) of interest and the tissue characterization module **124** may process the image based on the operator input.

It should be understood that the functionality discussed with respect to the system **100** is not limited to any ultrasound system type. For example, the system **100** may be housed within a cart-based system or may be implemented in a smaller, portable system as shown in FIG. **2**.

FIG. **2** illustrates a miniaturized ultrasound system **10** having a probe **12** configured to acquire ultrasonic data. As used herein, "miniaturized" means that the ultrasound system is a handheld or hand-carried device or is configured to be carried in a person's hand, pocket, briefcase-sized case, or backpack. For example, the ultrasound system **100** may be a hand-carried device having a size of a typical laptop computer, for instance, having dimensions of approximately 2.5 inches in depth, approximately 14 inches in width, and approximately 12 inches in height. The ultrasound system **100** may weigh about ten pounds, and thus is easily portable by the operator. An integrated display **14** (e.g., an internal display) is also provided and is configured to display a medical image.

The ultrasonic data may be sent to external device **24** via a wired or wireless network (or direct connection, for example, via a serial or parallel cable or USB port) **26**. In some embodiments, external device **24** may be a computer or a workstation having a display. Alternatively, external device **24** may be a separate external display or a printer capable of receiving image data from the hand carried ultrasound imaging device

**10** and of displaying or printing images that may have greater resolution than the integrated display **14**.

A user interface **28** (that may also include integrated display **14**) is provided to receive commands from an operator. The acquired image data may be acquired in a higher resolution than that displayable on the integrated display **14**.

As another example, the ultrasound device **10** may be a pocket-sized ultrasound system. By way of example, the pocket-sized ultrasound system may be approximately 2 inches wide, approximately 4 inches in length, and approximately 0.5 inches in depth and weigh less than 3 ounces. The pocket-sized ultrasound system may include a display, a user interface (i.e., keyboard) and an input/output (I/O) port for connection to the probe (all not shown). It should be noted that the various embodiments may be implemented in connection with a miniaturized ultrasound system having different dimensions, weights, and power consumption.

FIG. **3** illustrates an example of using the probe **106** of FIG. **1** to transmit ultrasonic waves to generate pressure waves and/or shear waves. During an ultrasound examination, the operator may image tissues by transmitting beams of ultrasound energy at an approximately 90 degree angle with respect to the probe face **107**. The beams or portions of the beams may also be steered to different angles with respect to the probe face **107**. An interface **150** is illustrated between a first type of tissue **152** and a second type of tissue **154**. By way of example, the interface **150** indicates a definite boundary such as a wall of the carotid artery or an edge of a tumor. The interface **150** may be visualized using standard ultrasound imaging. However, plaque morphology within the artery may not be specifically determined, such as whether the plaque is soft or hard plaque. Other examples are tissue characteristics of the tumor to determine properties that may be related to cancerous lesions and imaging areas of burned or otherwise damaged tissues to help determine an extent of grafting needed. In this example, the interface **150** and at least a portion of the probe face **107** are approximately planar with respect to each other.

A transmitted P-wave **156** is transmitted at an approximately 90 degree angle **170** with respect to the probe face **107** and intersects the interface **150** at normal incidence or at a 90 degree angle **158**. The transmitted P-wave **156** may be, for example, a longitudinal or compressional wave. At normal incidence, reflected P-waves **168** are reflected back to the probe **106** with few or no shear waves (S-waves) being generated. Each of the reflected P-waves **168** have an amplitude component. Portions of the ultrasound energy of the transmitted P-wave **156** continue past the boundary **150** as P-wave **176**.

When a transmitted P-wave **160** is transmitted at an oblique transmit angle **180** to intersect the interface **150** at an oblique angle **162**, a reflected S-wave **164** and a reflected P-wave **166** result. Therefore, some of the ultrasound energy is converted to shear or S-waves. Each of the reflected P-waves **166** has an amplitude component. Portions of the ultrasound energy of the transmitted P-wave **160** continue past the boundary **150** as S-wave **178** and P-wave **180**. The reflected P-wave **166** may be received by the probe **106** at a receive angle **182** that is the same magnitude as the transmit angle **180**.

Although the transmitted P-wave **156**, originating from transmission point or transmit origin **184**, is illustrated as being located proximate to the reflected P-wave **168**, it should be understood that the transmitted P-wave **156** and the reflected P-wave **168** share a common reflection point or receive origin **172**. The transmitted P-wave **160**, reflected S-wave **164** and the reflected P-wave **166** also share a common reflection point or receive origin **174**. The common

reflection points or receive origins **172** and **174** each represent a single point within the anatomy that may be described with an X, Y or X, Y, Z coordinate.

FIG. 4 illustrates a method for detecting tissue elasticity characteristics using diagnostic ultrasound scanning. The method may be accomplished using the system **100** and does not rely on any external source of pressure or movement, or on an additional probe.

At **200**, the operator initiates an ultrasonic scan, such as with the system **100** of FIG. 1. An image, such as a B-mode image, is displayed on the display **118**. In one example, the carotid artery may be imaged. The operator may use a linear probe having a size that allows scanning of desired anatomy with oblique angles. For example, a larger probe may be needed to determine tissue elasticity of structures further from the probe face **107** compared to structures located closer to the probe face **107**.

At **202**, the operator may optionally identify areas or portions of anatomy within the displayed ultrasound image for tissue characterization. For example, the operator may define an ROI comprising a portion of the carotid artery and surrounding tissue, such as to determine whether calcified plaque is present. The operator may also define one or more depths within the image wherein the processor **116** defines an ROI based on the one or more depths, or within a predetermined range proximate to and/or surrounding the depth. Automatic image analysis may also be used, either alone or together with operator definitions.

At **204** the operator may use the user input **120** to select tissue characterization and thus activate the tissue characterization module **124**. Optionally, the tissue characterization module **124** may be activated automatically, such as based on a selected protocol. At **206**, the tissue characterization module **124** may instruct the processor **116** and/or beamformer **110** to initiate an interleaved scanning mode such that alternating frames of data may be acquired.

FIGS. 5 and 6 illustrate an example of acquiring interleaved scanning sequences to detect differences in stiffness within tissues being imaged. FIG. 5 generally illustrates a first scanning sequence **250** used to acquire a normal incidence frame of data and FIG. 6 generally illustrates a second scanning sequence **270** used to acquire an oblique incidence frame of data. The first and second scanning sequences **250** and **270** are accomplished with the probe **106** having the probe face **107** as shown. In this example, a carotid artery **262** may be imaged. A boundary **260** is indicated that marks a change in tissue characteristics, which in this example is an outer wall of the carotid artery **262**. As discussed previously, the wall is visible to the operator using traditional ultrasound scanning, however, the hardness or morphology of the plaque is not visible to the operator. The probe face **107** and boundary **160** are approximately planar with respect to each other.

In general, ultrasound beams are transmitted and received to and from points within field of view (FOV) **269** of the probe **106** at normal and oblique angles. Therefore, limitations on determining tissue differences near side edges **266** and **268** of the FOV **269** of the probe **106** may be encountered because of the necessary transmit and receive scanning angles. However, it should be understood that angles other than a normal angle may be used with the oblique angle.

Returning to FIG. 4, at **208**, the processor **116** acquires a normal incidence frame of data using the first scanning sequence **250** (as shown in FIG. 5) wherein ultrasound transmit beams **252** and **254** are transmitted having a transmit angle **280** of approximately 90 degrees with respect to the probe face **107**. Because the probe face **107** and the boundary **260** are approximately parallel to each other, the transmit

beams **252** and **254** interface the boundary **260** at normal incidence or at an approximate 90 degree angle **282**. Although the example herein describes an angle of normal incidence, other angles may be used. Receive beams **256** and **258**, respectively, are returned from the boundary **260** and detected by the probe **106**. The receive beams **256** and **258** each have an amplitude component. Although only two transmit beams **252** and **254** and two receive beams **256** and **258** are shown, it should be understood that more transmit beams and receive beams may be used. Also, as discussed previously, the transmit beam **252** and receive beam **256** share a common reflection point (not shown) and the transmit beam **254** and receive beam **258** share another common reflection point (not shown). Each of the reflection points has a known coordinate location within the image or frame of data. The normal incidence frame of data may be used to display the image, such as a B-mode image, on the display **116**, as well as to calculate the stiffness of the tissue associated with a particular reflection point.

At **210**, the processor **116** acquires the oblique incidence frame of data using the second scanning sequence **270** (FIG. 6). The normal and oblique incidence frames of data are of the same physical structures and orientation within the patient. To acquire the oblique incidence frame of data, transmit beams **272** and **274** are transmitted at a transmit angle **284** that is other than 90 degrees with respect to the probe face **107**. Therefore, the transmit beams **272** and **274** interface with the boundary **260** with oblique incidence at angle **286**. Receive beams **276** and **278** interface with the probe face **107** at an oblique receive angle **288**. The receive beams **276** and **278** each have an amplitude component. The beamformer **110** and processor **116** determine the transmit and receive apertures based on known transmit parameters. For example, the transmit beam **272** is transmitted at a known transmit or steer angle (the transmit angle **284**) and the processor **116** may calculate an angle of incidence (angle **286**) with the boundary **260** based on the assumption that the boundary **260** is planar with respect to the probe face **107**. The receive angle **288** is determined as the equal and opposite oblique angle with respect to the transmit angle **284**. The angle of incidence (angle **286**) associated with each receive beam may be determined and may be used as described further below. In one embodiment, the transmit angle **284** and oblique receive angle **286** may be determined based on a general direction of the object or point of interest determined previously at **202**.

FIG. 7 illustrates another example of transmitting and receiving beams to acquire an oblique incidence frame of data. The oblique incidence frame of data covers at least a portion of the B-mode image, detecting many reflection points within the image. A transmit beam **300** is transmitted, originating from a transmission point (transmit origin) **362**, at a steer angle **302**. The steer angle **302** may be fixed such that a single steer angle is used for many transmit beams (not shown) across the FOV of the probe **106**. For example, a steer angle **302** of approximately 45 degrees with respect to the probe face **107** may be used. Alternatively, another oblique angle may be based at least on the location of desired reflection point(s) within the FOV. It should be understood that although only one transmit beam **300** is illustrated, there are many transmit beams.

Receive beam(s) **304**, **306** and **308** are fixed at receive angles **310**, **312** and **314**, respectively, and receive reflected ultrasound data based on the transmit beam **300**. Each of the first, second, and third receive beams **304**, **306** and **308** is associated with a first, second and third reflection point or receive origin **322**, **324** and **326**, respectively, at first, second and third depths **328**, **330** and **332**, respectively. Although not

illustrated, many more receive beams are also used. The apex of the receive focus trajectory is dynamically moved to acquire the three received image samples from the reflection points or receive origin **322**, **324**, **326** and so on. In other words, the receive beams **304**, **306** and **308** are snapshots of the same receive focus trajectory at different times. The receive beams **304**, **306** and **308** comprise an amplitude component as discussed previously. The receive angles **310**, **312** and **314** are the same with respect to each other and are equal and opposite angles with respect to the transmit steer angle **302**. While dynamically focusing, a receive beam apex is translated dynamically (illustrated by apex **316**, **318** and **210** associated with the first, second and third receive beams **304**, **306** and **308**, respectively) by the appropriate speed (e.g., **t1**, **t2**, **t3**) to ensure that the dynamic receive focus coincides with the transmit beam trajectory at every depth **328**, **330** and **332** given the size of the probe **106**.

Returning to FIG. 4, at **212** the tissue characterization module **124** identifies amplitude levels of received beams in the normal and oblique incidence frames of data. At **214**, the tissue characterization module **124** detects differences in shear wave properties between reflection points that are spatially the same within the normal and oblique incidence frames of data.

In general, the magnitude of the difference between the amplitude levels represents an amount of change in shear wave properties. Receive beams or echoes returned from reflection points within tissue that is relatively the same in property, such as stiffness, will have only slight differences in amplitude when comparing the receive beam amplitudes between the normal and oblique incidence frames of data. Receive beams returned from reflection points that correspond to a boundary between tissues having different stiffnesses have greater differences in amplitude between the normal and oblique incidence frames of data. For example, a greater difference in amplitude is experienced between the carotid wall and a hard or calcified plaque deposit than between the carotid wall and a soft plaque deposit.

Detecting the differences in shear wave properties in tissues may be accomplished in multiple ways. In one embodiment, the tissue characterization module **124** may calculate a stiffness parameter using known equations associated with Amplitude versus Offset (AVO) processes. The stiffness parameter may be used as an indicator of the stiffness of the tissue at the reflection point. In another embodiment, weighted subtraction may be used, wherein the amplitudes of the second frame of data may be weighted to increase the detected difference in stiffness. The weighting may be uniform or may be based on a curve to weight greater and lesser amplitude differences differently.

In another embodiment, for each reflection point, the characterization module **124** may compare the amplitude component of the receive beams from the normal and oblique incidence frames of data to determine an amplitude magnitude difference. Variations exist within normal tissues, and thus small amplitude magnitude differences are expected even within tissues that do not experience significant changes in stiffness. Therefore, a minimum difference threshold may be predetermined, such that reflection points having amplitude magnitude differences below the minimum difference threshold may be considered as having substantially the same stiffness. The tissue characterization module **124** may then access the tissue characterization data module **126** that may be stored in the memory **122** (as shown in FIG. 1). The tissue characterization data module **126** may comprise look-up tables, charts, curves, databases and the like that take into account the amplitude magnitude differences of each of the

identified receive beams, and, optionally, the angle of incidence that was determined at **210**. The tissue characterization module **124** may determine a stiffness parameter for each reflection point that represents the stiffness at that point based on the predetermined data within the tissue characterization data module **126**.

At **216**, the tissue characterization module **124** forms a representation based on the stiffness parameter(s) and/or amplitude magnitude difference(s) determined above for each reflection point. The tissue characterization module **124** may access a tissue characterization display module **128** that may comprise look-up tables, charts, curves, databases and the like. The parameters and/or amplitude magnitude differences may be compared to previously determined values within the characterization display module **128** that each may be correlated with a display effect. For example, a parametric overlay may be formed over the current B-mode image and may use display effects such as color, intensity, patterns and/or other effects such as flashing to indicate changes in tissue stiffness.

By way of example only, a spectrum of colors may be used by the tissue characterization display module **128** to form the overlay, such that reflection points representing a low level of stiffness difference, but still above the minimum threshold (if used), are displayed in a predetermined first color such as green. The reflection points representing a high level of stiffness difference may be displayed in a predetermined second color such as red. The reflection points between the low and high levels may be represented by other colors on the spectrum.

Optionally, the stiffness parameters and/or amplitude magnitude differences may be scaled such that the least difference and the greatest difference are always displayed with the same indications, regardless of the actual range of stiffness differences. Therefore, if a small degree of difference exists between the last and greatest differences, the display effect may be used to magnify the differences, and or to weight the differences to make all differences more apparent.

The method of FIG. 4 returns to **208** to acquire additional normal and oblique incidence frames of data. Although the description herein uses two different frames, in another embodiment more than two frames with different incidence directions may be acquired and combined to detect tissue elasticity characteristics or other property parameter(s) of the scanned medium.

FIG. 8 illustrates a parametric overlay **350** that may be displayed on the display **118** over the B-mode image that is based on the first data frame of FIG. 5. The parametric overlay **350** may have first and second areas **352** and **354** indicated in a first color. The first area **352** may correspond to a vessel wall and/or layer of plaque along of the carotid artery **262**, the upper edge of which may correspond to the boundary **260** in FIG. 5 that was visible to the operator on the B-mode image. Additional areas within the first area **352** have been indicated, specifically, first, second and third plaque deposits **356**, **358** and **360**. In the B-mode image, the first, second and third plaque deposits **356**, **358** and **360** and the first area **352** may have been displayed in the same way. Therefore, the operator would not be able to determine from the B-mode image the stiffness of the plaque and does not know whether the plaque is calcified or soft plaque. The overlay **350** indicates the amount of stiffness such that hard and soft plaque deposits may be indicated differently. For example, the first plaque deposit **356** may be hard plaque and thus is more stiff than the first area **352** that indicates the vessel wall. The second plaque deposit **358** may be soft plaque, and although more stiff than the first area **352**, is less stiff than the first plaque deposit **356**.

The overlay 350 may thus indicate the first area 352, first plaque deposit 356 and second plaque deposits 358 differently, such as with different colors, patterns, intensity and the like.

It should be understood that the differences in tissue stiffness may be displayed in other ways as well. For example, the display of the data may be interactive such that the operator may move a cursor over a desired location and/or touch a location on a touch screen. The stiffness data associated with the identified location may then be displayed, such as in a numerical reference that may be scaled based on the current image or scaled based on predetermined data. Also, a report, chart or other graphical indication may be provided.

A technical effect of at least one embodiment is the ability to detect and display tissue differences related to stiffness using traditional ultrasound imaging. Frames of data are acquired at normal and oblique incidence with respect to structures in the body. The receive beams have an amplitude component that is compared between the normal and oblique incidence frames of data. A greater difference in amplitude between the two frames indicates a reflection point that creates a greater amount of shear or S-waves, indicating a tissue boundary that has a high change in stiffness between the tissues. A parametric overlay may be formed based on the amplitude differences to display the changes in stiffness to the operator.

It is to be understood that the above description is intended to be illustrative, and not restrictive. For example, the above-described embodiments (and/or aspects thereof) may be used in combination with each other. Although the descriptions herein primarily describe two different frames, it should be understood that more than two frames with different incidence directions may be acquired and combined to achieve a similar result. In addition, many modifications may be made to adapt a particular situation or material to the teachings of the invention without departing from its scope. While the dimensions and types of materials described herein are intended to define the parameters of the invention, they are by no means limiting and are exemplary embodiments. Many other embodiments will be apparent to those of skill in the art upon reviewing the above description. The scope of the invention should, therefore, be determined with reference to the appended claims, along with the full scope of equivalents to which such claims are entitled. In the appended claims, the terms “including” and “in which” are used as the plain-English equivalents of the respective terms “comprising” and “wherein.” Moreover, in the following claims, the terms “first,” “second,” and “third,” etc. are used merely as labels, and are not intended to impose numerical requirements on their objects. Further, the limitations of the following claims are not written in means-plus-function format and are not intended to be interpreted based on 35 U.S.C. §112, sixth paragraph, unless and until such claim limitations expressly use the phrase “means for” followed by a statement of function void of further structure.

What is claimed is:

1. An ultrasound system, comprising:

an ultrasound probe for transmitting transmit beams and receiving receive ultrasound beams;

a processor for controlling the ultrasound probe to direct a first plurality of transmit beams at a first angle to acquire a first incidence frame of data and a second plurality of transmit beams at a second angle to acquire a second incidence frame of data, wherein the first and second angles are different with respect to each other; and

a tissue characterization module for comparing the first and second incidence frames of data to determine relative

tissue stiffness of a scanned medium based on differences between the received ultrasound beams, wherein the tissue characterization module subtracts the first and second incident frames of data to determine the differences.

2. The system of claim 1, wherein the ultrasound probe comprises a probe face, wherein the first angle is 90 degrees with respect to the probe face and the second angle is an oblique angle with respect to the probe face.

3. The system of claim 1, further comprising:

a tissue characterization display module for forming a representation of the differences between received diagnostic ultrasound beams; and

a display for displaying the representation.

4. The system of claim 1, further comprising:

a display for displaying an image based at least on the first incidence frame of data; and

a tissue characterization display module for displaying a parametric overlay on the image based on the differences between the received diagnostic ultrasound beams.

5. The system of claim 1, wherein the processor acquires the first and second frames of data in an interleaved scanning mode.

6. The system of claim 1, wherein the ultrasound system is one of a cart-based system and a portable system.

7. A method for detecting differences in tissue, the method comprising:

acquiring a normal incidence frame of data by using an ultrasound probe to transmit ultrasound beams at a first angle 90 degrees with respect to an ultrasound probe face;

acquiring an oblique incidence frame of data by using the ultrasound probe to transmit ultrasound beams at a second angle that is different than the first angle, the second angle being an oblique angle with respect to the ultrasound probe face;

determining a relative tissue stiffness of a scanned medium based on differences between receive beams for the normal and oblique incidence frames of data, wherein the differences are determined by subtracting the normal and oblique incident frames of data; and

displaying a tissue representation based on the differences.

8. The method of claim 7, wherein acquiring the oblique incident frame of data further comprises:

transmitting the transmit beams at the first angle with respect to the probe face; and

receiving the receive beams at the second angle with respect to the probe face, the first and second angles being the same in magnitude and opposite in direction with respect to each other.

9. The method of claim 7, wherein the differences are associated with reflection points within each of the normal incidence frame of data and oblique incidence frame of data.

10. The method of claim 7, further comprising:

displaying an image based on at least the normal incidence frame of data;

determining an object boundary within the image based on one of automatic image analysis and an operator input; and

determining transmit and receive angles with respect to the probe face, the transmit and receive angles being associated with the transmit and receive beams, respectively, and forming incidence and reflection angles, respectively, with the object boundary that are opposite with respect to each other.

## 11

11. The method of claim 7, wherein acquiring an oblique incidence frame of data further comprises:

transmitting transmit beams from a transmit origin associated with the probe face to interface with reflection points that are at different depths from the probe face; dynamically shifting a receive origin associated with the probe face with respect to the transmit origin to form a plurality of receive origins; and receiving the receive beams reflected from the reflection points with the plurality of receive origins, the transmit and receive beams forming a nonzero angle at the reflection points.

12. The method of claim 7, wherein the differences comprise a range of differences, the representation displaying the range of differences with a range of indicators.

13. The method of claim 7, wherein the representation displays the differences using at least one of a parametric overlay, a color overlay, a chart, and a graphical indicator responsive to an operator controlled pointer.

14. The method of claim 7, wherein at least one of the differences indicates a stiffness parameter associated with at least one reflection point in the normal and oblique incidence frames of data.

15. A method for detecting differences in tissue, the method comprising:

acquiring a normal incidence frame of data by using an ultrasound probe to transmit ultrasound beams at 90 degrees with respect to a probe face;

acquiring an oblique incidence frame of data by using the ultrasound probe to transmit ultrasound beams at a second angle different than the first angle, the second angle being an oblique angle with respect to the probe face; displaying an image based on at least the normal incidence frame; and

displaying a tissue representation of relative tissue stiffness as a parametric overlay on the image, the parametric overlay being based on differences between the normal and oblique incidence frames of data, wherein the differences are determined by subtracting the normal and oblique incident frames of data.

16. The method of claim 15, the parametric overlay further displaying differences in a plurality of colors wherein each color represents a difference range.

17. The method of claim 15, wherein the parametric overlay further displaying the differences with a range of indicators.

18. The method of claim 15, further comprising determining amplitude differences between the normal and oblique incidence frames of data in order to determine the differences between the normal and oblique incidence frames of data.

19. The system of claim 1, wherein the tissue characterization module determines the relative tissue stiffness of the scanned medium without using a tissue elasticity model.

20. The system of claim 1, wherein the tissue characterization module determines the relative tissue stiffness of the

## 12

scanned medium by calculating differences between a plurality of reflection points that are spatially located in a same position within the first and second incidence frames of data by subtracting amplitudes of the first and second incidence frames of data.

21. The system of claim 1, wherein the tissue characterization module further (i) determines a stiffness parameter of the scanned medium for a plurality of reflection points using received ultrasound beams above a minimum threshold difference of a determined amplitude magnitude difference between the received ultrasound beams and (ii) forms a representation based on the stiffness parameter to indicate changes in tissue stiffness.

22. The system of claim 1, wherein the ultrasound probe is configured to operate at diagnostic imaging ultrasound amplitudes in an ultrasound imaging scan.

23. The method of claim 11, wherein dynamically shifting a receive origin associated with the probe face with respect to the transmit origin to form a plurality of receive origins comprises dynamically moving an apex of a receive focus trajectory to acquire a plurality of samples from the reflection points with the apex translated at a speed such that a dynamic receive focus coincides with a trajectory of the transmit beams at a plurality of focus depths.

24. The method of claim 15, further comprising indicating an amount of tissue stiffness with hard and soft plaque deposits indicated differently.

25. The system of claim 1, wherein the tissue characterization module determines the relative tissue stiffness using a stiffness parameter and without using simulated data.

26. The system of claim 1, wherein the ultrasound probe comprises a probe face and at least one of the transmit beams forms an oblique angle with the probe face and generates a reflected shear wave, and the processor is further configured to generate a B-mode image using the first and second incidence frames of data.

27. The system of claim 1, wherein the processor is further configured to process the incidence frames of data to generate an image for display and to calculate a tissue stiffness.

28. The system of claim 1, wherein the ultrasound probe is configured to perform diagnostic ultrasound scanning and determine the relative tissue stiffness using the transmit ultrasound beams from the diagnostic ultrasound scanning.

29. The system of claim 1, wherein at least some of the first and second plurality of transmit beams are not parallel to other ones of the first and second plurality of transmit beams.

30. The system of claim 1, wherein the transmit beams comprise ultrasound beams having an amplitude and energy for diagnostic ultrasound imaging to generate a B-mode image.

31. The method of claim 7, further comprising generating a B-mode image for display.

\* \* \* \* \*

专利名称(译)	使用超声成像进行组织表征的系统和方法		
公开(公告)号	<a href="#">US9125589</a>	公开(公告)日	2015-09-08
申请号	US11/801322	申请日	2007-05-09
[标]申请(专利权)人(译)	通用电气公司		
申请(专利权)人(译)	通用电气公司		
当前申请(专利权)人(译)	通用电气公司		
[标]发明人	SORNES ANDERS RASMUS		
发明人	SORNES, ANDERS RASMUS		
IPC分类号	A61B8/00 A61B8/08 A61B5/02		
CPC分类号	A61B8/08 A61B5/02007 A61B8/485		
其他公开文献	US20080281196A1		
外部链接	<a href="#">Espacenet</a>	<a href="#">USPTO</a>	

摘要(译)

超声系统包括用于发射发射波束和接收接收波束的超声探头。处理器控制超声探头以在第一方向上引导发射波束以获取第一入射数据帧和第二方向以获取第二入射数据帧，其中第一和第二方向相对于彼此不同。组织表征模块比较正常和倾斜入射的数据帧，以基于接收波束之间的幅度差来确定扫描介质的至少一个属性参数。

