



US 20140148699A1

(19) **United States**
(12) **Patent Application Publication**
SHIM et al.

(10) **Pub. No.: US 2014/0148699 A1**
(43) **Pub. Date: May 29, 2014**

(54) **ULTRASONIC PROBE APPARATUS AND CONTROL METHOD THEREOF**

Publication Classification

(71) Applicant: **SAMSUNG ELECTRONICS CO., LTD.**, Suwon-si (KR)

(51) **Int. Cl.**
A61B 8/08 (2006.01)

(72) Inventors: **Hwan SHIM**, Yongin-si (KR);
Hyun-woo KOH, Yongin-si (KR);
Seoung-hun KIM, Hwaseong-si (KR);
Young-tae KIM, Seongnam-si (KR)

(52) **U.S. Cl.**
CPC *A61B 8/5246* (2013.01); *A61B 8/488* (2013.01)
USPC **600/441**; **600/443**

(73) Assignee: **SAMSUNG ELECTRONICS CO., LTD.**, Suwon-si (KR)

(57) **ABSTRACT**

(21) Appl. No.: **14/092,193**

An ultrasonic probe apparatus includes an ultrasound transceiver adapted to receive ultrasonic echo signals reflected after transmitting unfocused or defocused ultrasonic signals having a first frame rate; a converter adapted to convert ultrasonic echo signals received by the ultrasound transceiver into digital signals; an image processor adapted to generate a plurality of image data by processing the digital signals; a combiner adapted to combine the plurality of image data having a first frame rate into a plurality of composite image data having a second frame rate; and a transmitter adapted to transmit the plurality of composite image data having the second frame rate.

(22) Filed: **Nov. 27, 2013**

(30) **Foreign Application Priority Data**

Nov. 29, 2012 (KR) 2012-0137219

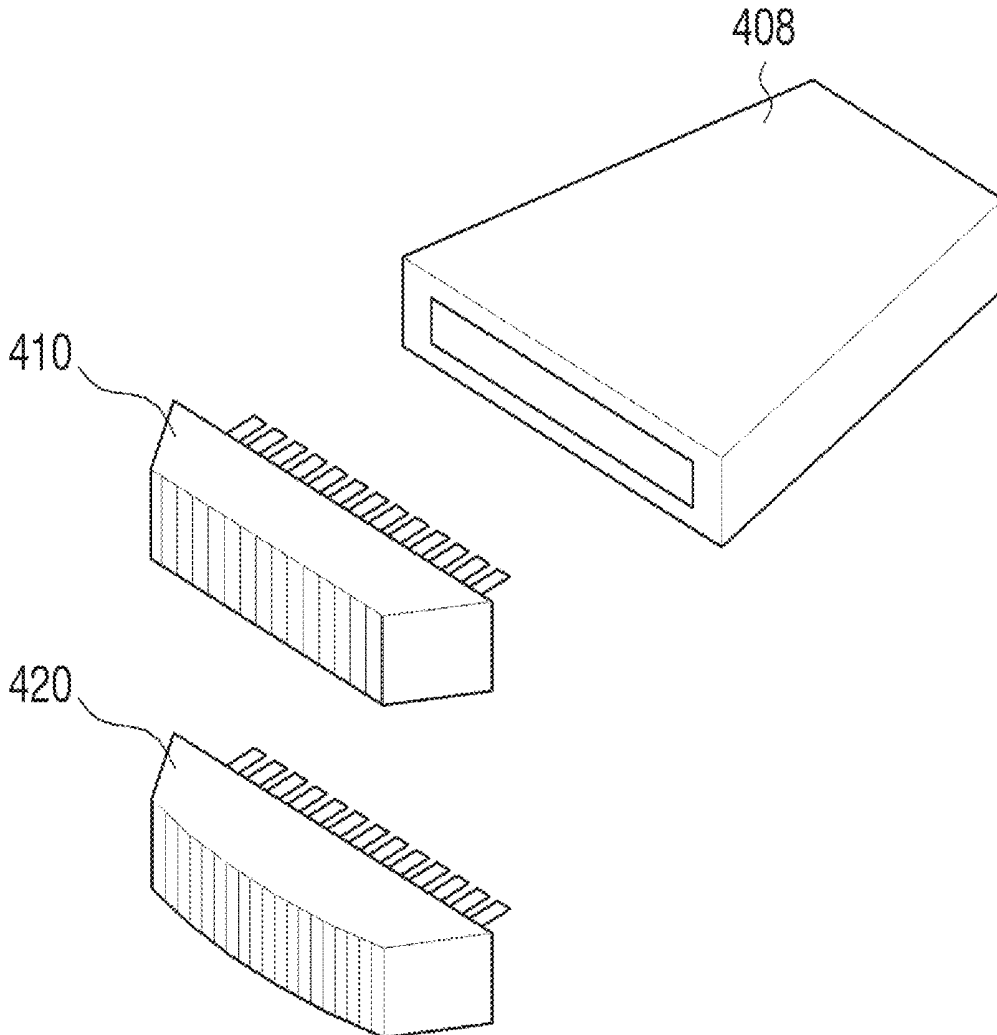

FIG. 1

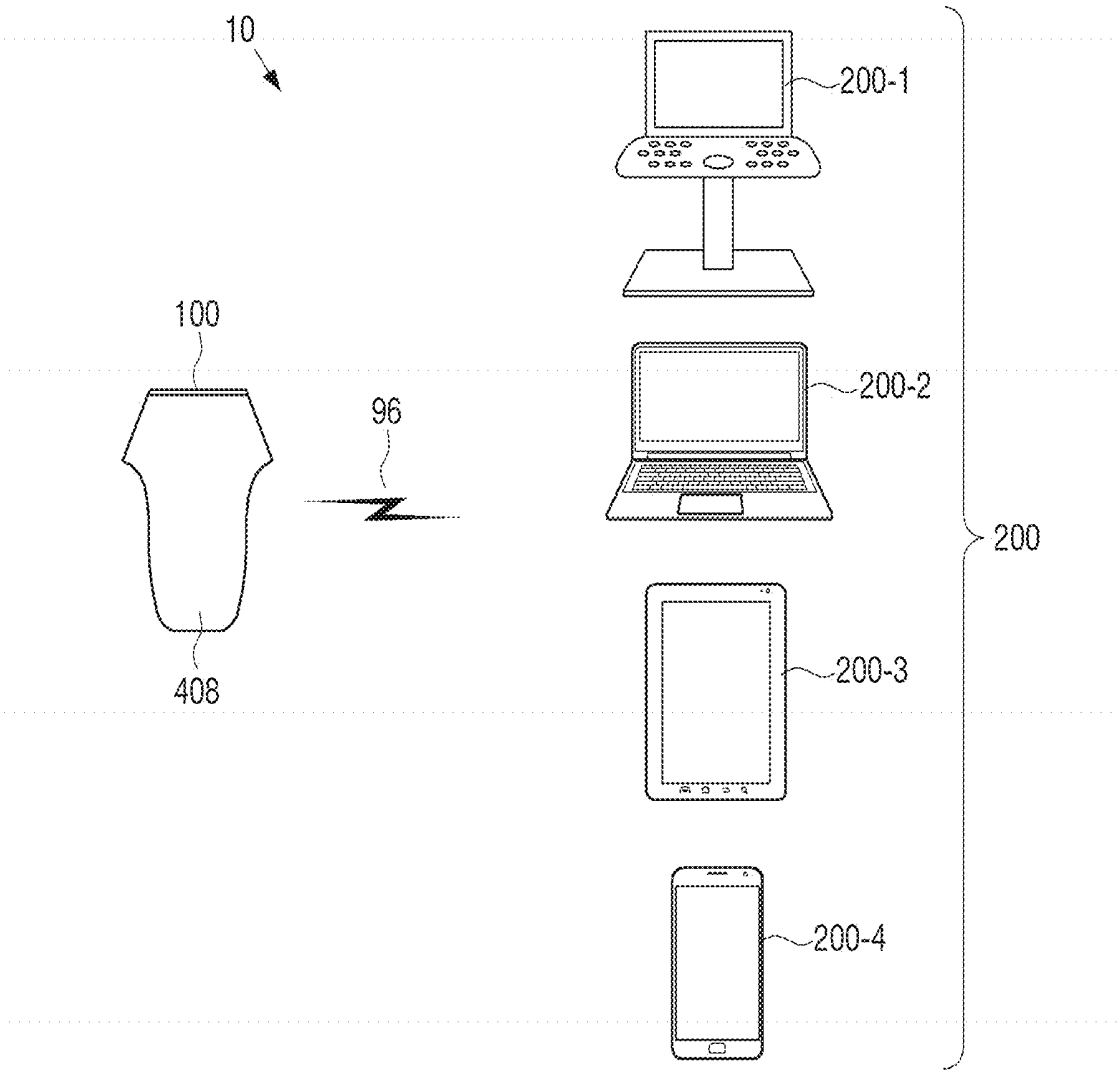

FIG. 2

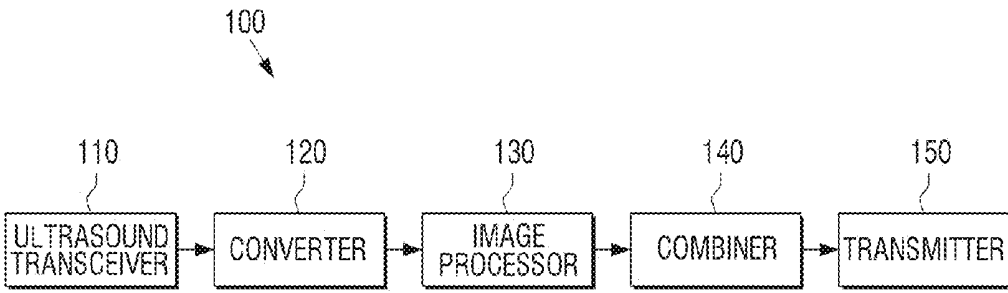

FIG. 3

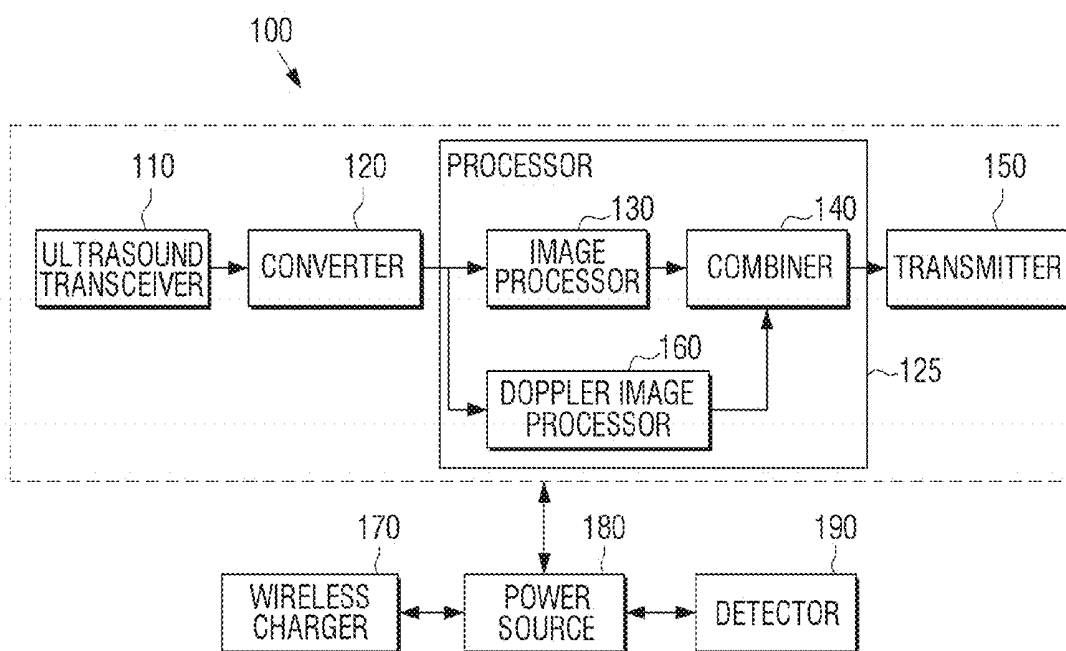

FIG. 4

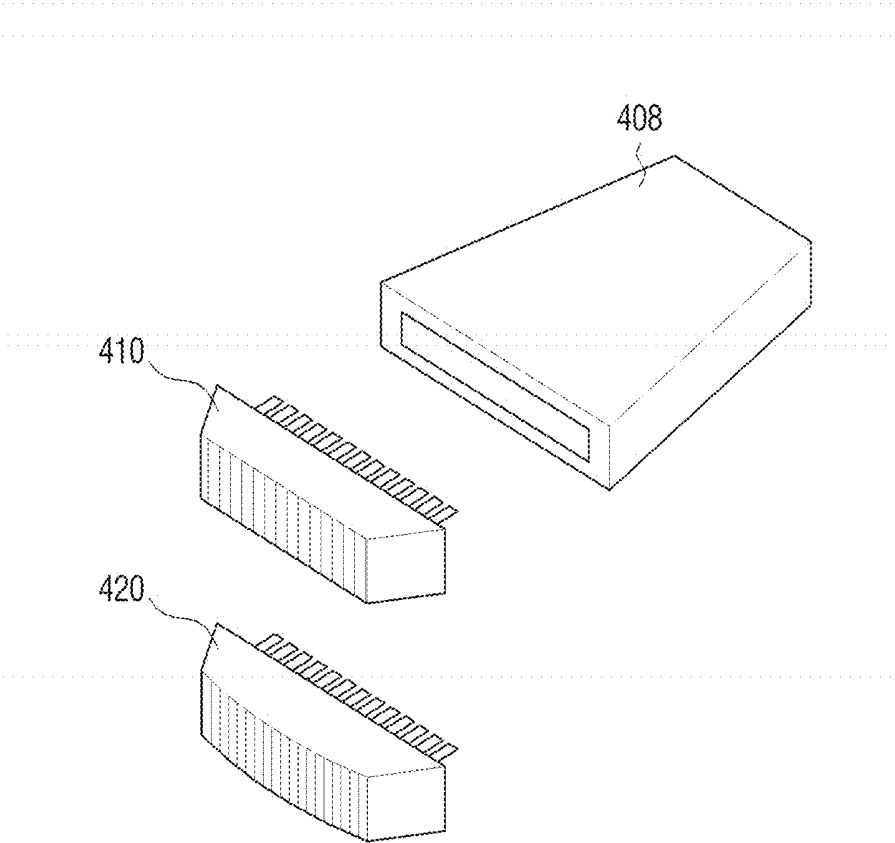

FIG. 5

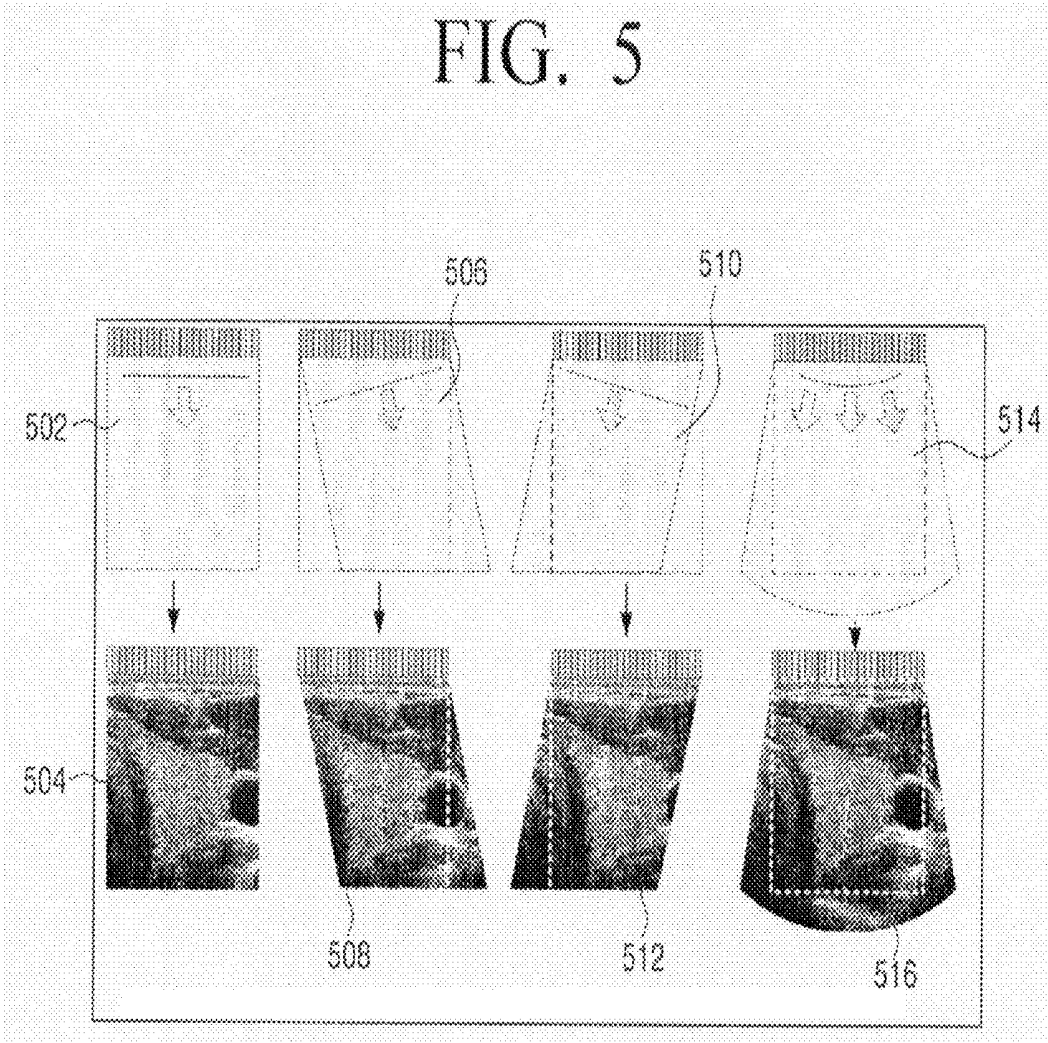

FIG. 6

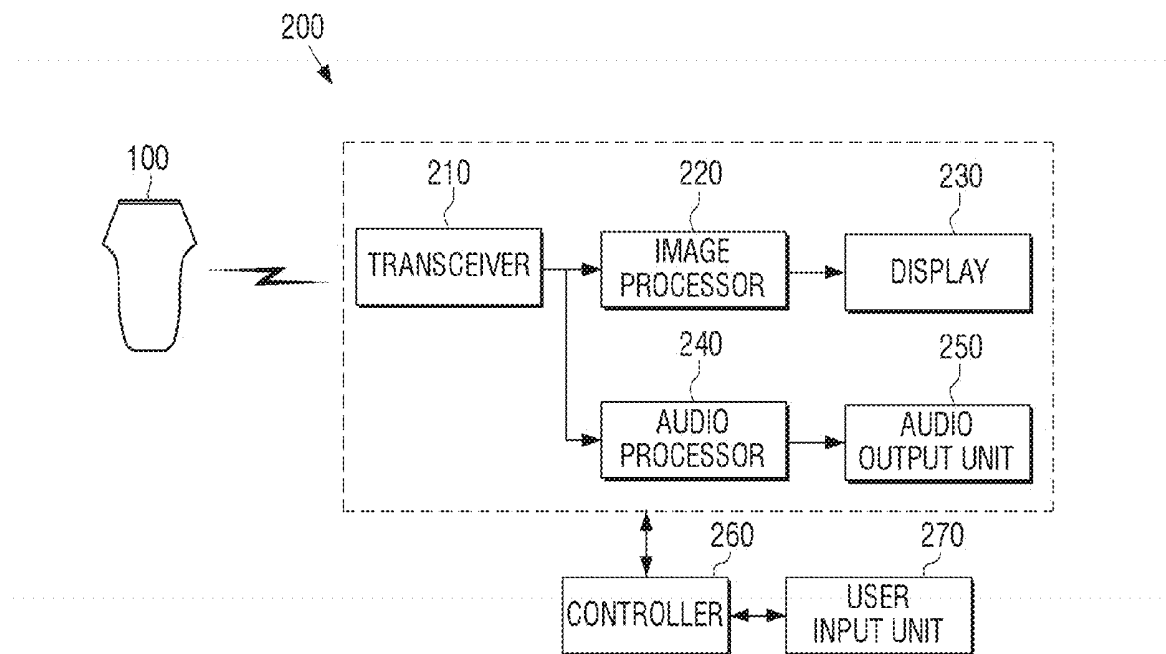

FIG. 7

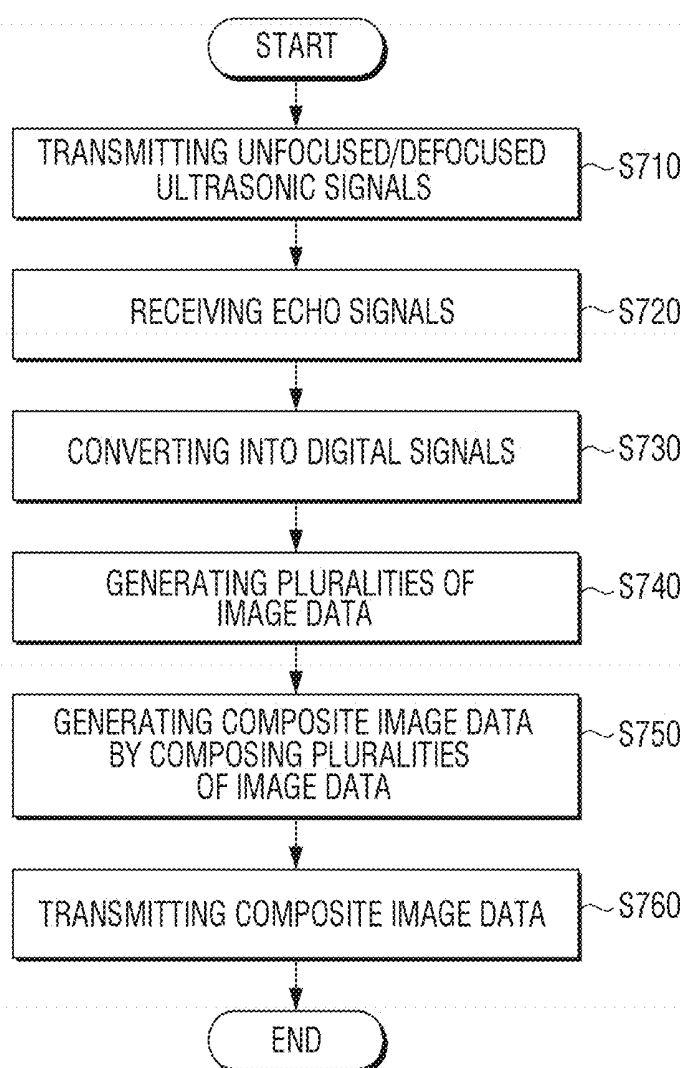
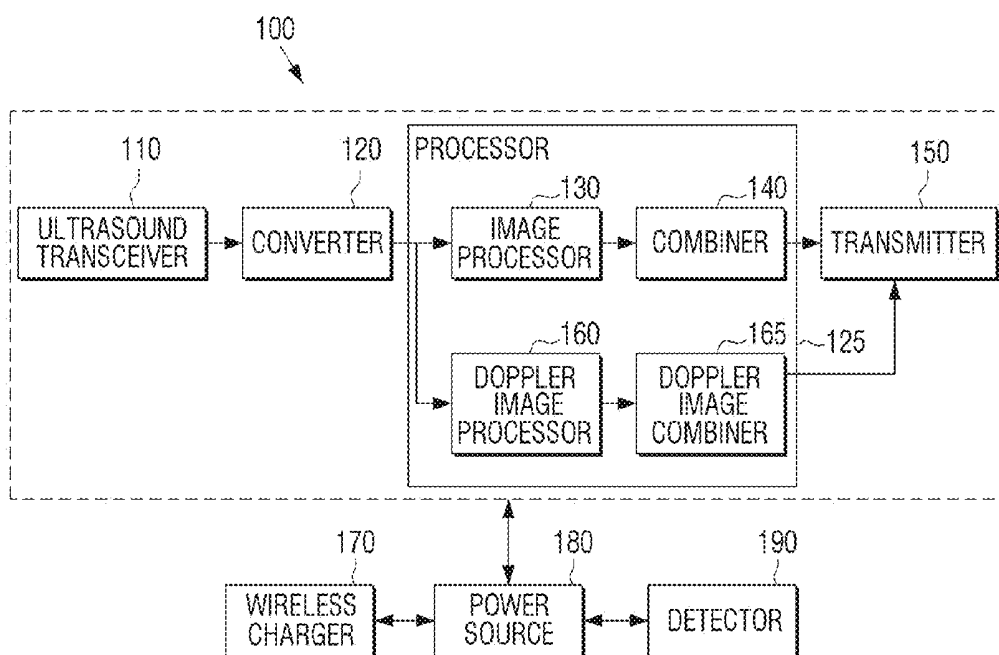

FIG. 8



ULTRASONIC PROBE APPARATUS AND CONTROL METHOD THEREOF

CROSS-REFERENCE TO RELATED APPLICATION

[0001] This application claims priority from Korean Patent Application No. 10-2012-0137219 filed Nov. 29, 2012 in the Korean Intellectual Property Office, the disclosure of which is incorporated herein by reference in its entirety.

BACKGROUND

[0002] 1. Field

[0003] Apparatuses and methods consistent with exemplary embodiments relate to an ultrasonic probe apparatus that can transmit ultrasonic image data, which are generated by using echo signals reflected in response to transmitting unfocused or defocused ultrasonic signals, to an external display apparatus and a control method thereof.

[0004] 2. Description of the Related Art

[0005] An ultrasound is widely used in the medical field to obtain the internal information of an object because of non-invasive and nondestructive characteristics. The ultrasonic diagnostic system is able to provide doctors in real-time with high-resolution images of the object without the need of a surgery, thereby being frequently used in the medical field.

[0006] The probe of the ultrasonic apparatus includes a transducer array to transmit ultrasonic signals and receive reflected ultrasonic signals as echo signals. The ultrasonic probe transmits the received echo signals to the external display apparatus as analog signals. However, the ultrasonic probe needs a heavy multi-conductor wire for transmitting analog electrical signals, which unduly increases the weight of the ultrasonic probe. Also, the analog signal contains a great amount of a signal noise, which may result in poor image quality.

[0007] Further, in the ultrasonic apparatus, there is a method to generate image data by transmitting and reflecting focused ultrasonic signals and a method to generate image data by transmitting and reflecting unfocused or defocused ultrasonic signals. If a method for generating the focused ultrasonic signals is used, a separate configuration such as a beamformer is needed to generate the focused ultrasonic signals and the frame rate is small, making it difficult to apply in a variety of applications.

[0008] Accordingly, there is a need for methods and apparatuses for transmitting digital image data generated by using unfocused or defocused ultrasonic signals to the external display apparatus.

SUMMARY

[0009] Exemplary embodiments may address at least the above problems and/or disadvantages and other disadvantages not described above. Also, the exemplary embodiments are not required to overcome the disadvantages described above, and an exemplary embodiment may not overcome any of the problems described above.

[0010] One or more exemplary embodiments provide an ultrasonic probe apparatus that can transmit digital image data generated by using unfocused or defocused ultrasonic signals to an external display apparatus and a control method thereof.

[0011] In accordance with an aspect of an exemplary embodiment, there is provided an ultrasonic probe apparatus,

which may include an ultrasound transceiver adapted to receive ultrasonic echo signals reflected by transmitting unfocused or defocused ultrasonic signals having a first frame rate; a converter adapted to convert each of the plurality of ultrasonic echo signals received by the ultrasound transceiver into a digital signal; an image processor adapted to generate a plurality of image data by processing a plurality of digital signals converted through the converter; a combiner adapted to combine the plurality of image data having a first frame rate into a plurality of composite image data to output them in a second frame rate; and a transmitter adapted to transmit the plurality of composite image data having the second frame rate to an external display apparatus.

[0012] The image processor may include a Doppler image processor adapted to generate a plurality of Doppler images by performing Doppler processing for each of the plurality of converted digital signals.

[0013] The Doppler processing may include at least one of color Doppler processing, B-mode image processing, and spectral Doppler processing.

[0014] If image data having different sizes are generated by receiving the echo signals that are the defocused ultrasonic signals reflected or changing of a steering angle of the ultrasonic probe apparatus, the image processor may edit the image data having different sizes into image data having a predetermined size.

[0015] The first frame rate may be determined depending on a measuring depth to be measured by using the ultrasonic probe apparatus.

[0016] The second frame rate may be determined depending on a frame rate which the transmitter can transmit.

[0017] The transmitter may transmit wirelessly the plurality of composite image data to the display apparatus.

[0018] The ultrasound transceiver may be detachable from the ultrasonic probe apparatus.

[0019] The ultrasonic probe apparatus may include a wireless charger adapted to charge power of the ultrasonic probe apparatus by using one of a magnetic induction method and a magnetic resonance method.

[0020] The ultrasonic probe apparatus may include a detector adapted to detect a user touch; and a power source adapted to apply power to the ultrasonic probe apparatus if the user touch is detected through the detector.

[0021] According to an aspect of an exemplary embodiment, a control method of an ultrasonic probe apparatus may include receiving a plurality of ultrasonic echo signals reflected by transmitting unfocused or defocused ultrasonic signals having a first frame rate; converting each of the plurality of received ultrasonic echo signals into a digital signal; generating a plurality of image data by processing the plurality of converted digital signals; composing the plurality of image data having the first frame into a plurality of composite image data to output them in a second frame rate; and transmitting the plurality of composite image data having the second frame rate to an external display apparatus.

[0022] The generating a plurality of image data by processing the plurality of converted digital signals may include generating a plurality of Doppler images by performing Doppler processing for each of the plurality of converted digital signals.

[0023] The Doppler processing may include at least one of color Doppler processing, B-mode image processing, and spectral Doppler processing.

[0024] The generating a plurality of image data by processing the plurality of converted digital signals may include, if image data having different sizes are generated by receiving the echo signals that are the defocused ultrasonic signals reflected or changing of a steering angle of the ultrasonic probe apparatus, editing the image data having different sizes into image data having a predetermined size.

[0025] The first frame rate may be determined depending on a measuring depth to be measured by using the ultrasonic probe apparatus.

[0026] The second frame rate may be determined depending on a frame rate which the transmitter can transmit.

[0027] The transmitting the plurality of composite image data having the second frame rate to an external display apparatus may include transmitting wirelessly the plurality of composite image data to the display apparatus.

[0028] The control method may include charging power of the ultrasonic probe apparatus by using one of a magnetic induction method and a magnetic resonance method.

[0029] The control method may include detecting a user touch; and applying, if the user touch is detected, power to the ultrasonic probe apparatus.

[0030] With an ultrasonic probe apparatus according to various exemplary embodiments, image data obtained by the ultrasonic probe apparatus can be applied to various applications, and, because configuration such as a beamformer and a mixer is not needed, a circuit can be easily integrated within the ultrasonic probe apparatus.

[0031] Also, because the ultrasonic probe apparatus processes echo signals and transmits image data, an external apparatus charges simple conversion of UI or scan, thereby requiring low computational complexity. Accordingly, the external apparatus may be implemented with various devices such as a personal computer, a smart phone, etc. in addition to a general ultrasonic display apparatus.

[0032] In addition, when transmitting image data wirelessly, the ease of use of the ultrasonic probe apparatus can be increased, and data distortion caused by analog wired connection can be minimized.

BRIEF DESCRIPTION OF THE DRAWINGS

[0033] The above and/or other aspects will become more apparent by describing certain exemplary embodiments, with reference to the accompanying drawings, in which:

[0034] FIG. 1 is a view illustrating an ultrasonic diagnostic system according to an exemplary embodiment;

[0035] FIG. 2 is a block diagram schematically illustrating a configuration of an ultrasonic probe apparatus according to an exemplary embodiment;

[0036] FIG. 3 is a block diagram illustrating a configuration of an ultrasonic probe apparatus according to an exemplary embodiment;

[0037] FIG. 4 is a view illustrating an ultrasound transceiver that can be detached according to an exemplary embodiment;

[0038] FIG. 5 is a view explaining an imaging method according to an exemplary embodiment;

[0039] FIG. 6 is a block diagram schematically illustrating a configuration of an external display apparatus according to an exemplary embodiment;

[0040] FIG. 7 is a flowchart for explaining a control method of an ultrasonic probe apparatus according to an exemplary embodiment; and

[0041] FIG. 8 is a block diagram illustrating a configuration of an ultrasonic probe apparatus according to an exemplary embodiment.

DETAILED DESCRIPTION OF EXEMPLARY EMBODIMENTS

[0042] Certain exemplary embodiments are described in greater detail below with reference to the accompanying drawings.

[0043] In the following description, the same drawing reference numerals are used for the same elements even in different drawings. The matters defined in the description, such as detailed construction and elements, are provided to assist in a comprehensive understanding of exemplary embodiments. Thus, it is apparent that exemplary embodiments can be carried out without those specifically defined matters. Also, well-known functions or constructions are not described in detail since they would obscure exemplary embodiments with unnecessary detail.

[0044] FIG. 1 is a view illustrating an ultrasonic diagnostic system according to an exemplary embodiment. An ultrasonic diagnostic system 10 includes an ultrasonic probe apparatus 100 and a display apparatus 200 which may be physically detached from the main body 408 of the ultrasonic probe apparatus 100.

[0045] The ultrasonic probe apparatus 100 generates unfocused or defocused ultrasonic signals, and transmits the generated ultrasonic signals to a diagnostic object. For example, the ultrasonic probe apparatus 100 may transmit the ultrasonic signals to generate image data with a first frame rate. For example, the ultrasonic probe apparatus 100 may transmit the ultrasonic signals so that three thousand sheets of image data are acquired per second.

[0046] The ultrasonic probe apparatus 100 may transmit the ultrasonic signals to generate image data with a first frame rate. For example, the ultrasonic probe apparatus 100 may transmit the ultrasonic signals so that three thousand sheets of image data are acquired per second.

[0047] The ultrasonic probe apparatus 100 obtains ultrasonic data by receiving echo signals reflected by the diagnostic object, and converts the analog ultrasonic data into digital signals.

[0048] The ultrasonic probe apparatus 100 generates a plurality of image data by performing image processes (e.g., demodulation, decimation) for the ultrasonic data converted into digital signals.

[0049] The ultrasonic probe apparatus 100 generates a plurality of composite image data by composing the plurality of image data to have a second frame rate in order to transmit the plurality of image data to the display apparatus 200. For example, if three thousand sheets of image data are generated per second, the ultrasonic probe apparatus 100 may generate hundred composite image data by composing thirty image data. For example, the ultrasonic probe apparatus 100 may generate a plurality of composite image data by composing the plurality of image data by considering the resolution of the image data and the frame rate with which it can communicate with the display apparatus 200.

[0050] The ultrasonic probe apparatus 100 may transmit the generated composite image data to the display apparatus 200. For example, because the ultrasonic probe apparatus 100 transmits the composite image data as the digital data to the display apparatus 200, the image data may be transmitted wirelessly via a network 96. Also, even though the ultrasonic probe apparatus 100 may use wires for transmitting and receiving signals, amount and weight of the wires may be

substantially reduced as compared to that of the related art ultrasound apparatus which transmits the image data as analog signals.

[0051] The display apparatus 200 outputs audio and/or video signals by processing the composite image data received from the ultrasonic probe apparatus 100. For example, the display apparatus 200 may control the size of the composite image data by considering the resolution of the display apparatus 200.

[0052] As illustrated in FIG. 1, the display apparatus 200 according to an exemplary embodiment may be implemented as at least one of an ultrasonic diagnostic system 200-1, a personal computer (PC) 200-2, a tablet computer 200-3, and a smart phone 200-4. However, this is only an exemplary embodiment, and the display apparatus 200 may be implemented with different devices.

[0053] The ultrasonic probe apparatus 100 can transmit the composite image data to a single display apparatus 200 or to multiple display apparatuses.

[0054] By the ultrasonic diagnostic system as described above, users will be able to receive more easily diagnostic services using ultrasonic waves.

[0055] The ultrasonic probe apparatus 100 is described below in detail with reference to FIGS. 2 to 5, and the display apparatus 200 is described below in detail with reference to FIG. 6.

[0056] FIG. 2 is a block diagram schematically illustrating a configuration of the ultrasonic probe apparatus 100 according to an exemplary embodiment. As illustrated in FIG. 2, the ultrasonic probe apparatus 100 includes an ultrasound transceiver 110, a converter 120, an image processor 130, a combiner 140, and a transmitter 150.

[0057] The ultrasound transceiver 110 generates unfocused or defocused ultrasonic signals, and transmits the generated ultrasonic signals to a diagnostic object (e.g., a human body). For example, the unfocused ultrasonic signal may be a plane wave, and the defocused ultrasonic signal may be a fan-shaped spherical wave.

[0058] The ultrasound transceiver 110 obtains ultrasonic data by receiving echo signals reflected by the diagnostic object, in an analog form.

[0059] The converter 120 converts the analog ultrasonic data into a digital data. For example, the converter 120 may include an analog to digital converter (ADC).

[0060] The image processor 130 obtains image data by image-processing the digital ultrasonic data. In detail, the image processor 130 may perform the image processing of the ultrasonic data by performing at least one of demodulation and decimation, thereby generating the plurality of image data.

[0061] If image data having different sizes are generated due to receiving echo signals that are the reflected in response to transmitting the defocused ultrasonic signals or changing of a steering angle of the ultrasonic probe apparatus, the image processor 130 may edit the image data having different sizes into image data of a predetermined size. In detail, when the combiner 140 combines the plurality of image data, if the plurality of image data is to take different areas, noise may occur. Therefore, the image processor 130 may edit the plurality of image data so that the plurality of image data becomes images for the same area and output the edited image data to the combiner 140.

[0062] The combiner 140 combines the plurality of image data into a plurality of composite image data in order to output the plurality of image data received with a first frame rate in a second frame rate.

[0063] In order to increase the resolution of images that will be displayed and to decrease signal-to-noise ratio, the combiner 140 may generate a plurality of composite image data by composing image data more than a predetermined number of frames. For example, the combiner 140 may generate composite image data by composing image data of more than 100 frames.

[0064] Also, the combiner 140 may combine the plurality of image data by considering a frame rate by which the ultrasonic probe apparatus 100 can communicate with the display apparatus 200. For example, if the ultrasonic probe apparatus 100 transmits image data of less than 100 frames per second to the display apparatus 200, the ultrasonic probe apparatus 100 may configure and combine the image data so that composite image data have a frame rate of less than 100 frames per second.

[0065] The transmitter 150 transmits the composite image data combined by the combiner 140 to the display apparatus 200 via a network 96, by using a wireless communication module such as WiFi, Bluetooth, UWB, WiGig, Zigbee, etc. As another example, the transmitter 150 may transmit the composite image data by using a wired communication module such as IEEE 1394, USB, etc.

[0066] By using the ultrasonic probe apparatus 100 as described above, the users may easily receive the portable ultrasonic diagnostic service.

[0067] FIG. 3 is a block diagram illustrating a configuration of an ultrasonic probe apparatus 100 according to an exemplary embodiment. As illustrated in FIG. 3, the ultrasonic probe apparatus 100 may include an ultrasound transceiver 110, a converter 120, a processor 125, a transmitter 150, a wireless charger 170, a power source 180, and a detector 190. The processor 125 may include an image processor 130, a combiner 140, and a Doppler image processor 160.

[0068] The ultrasound transceiver 110 generates unfocused ultrasonic signals as a plane wave or defocused ultrasonic signals as a spherical wave, transmits the generated ultrasonic signals to the object, and obtains ultrasonic data by receiving echo signals.

[0069] For example, the ultrasound transceiver 110 may transmit the ultrasonic signals so that image data having a first frame rate are generated. For example, the first frame rate may be determined depending on a measuring depth h to be measured by using the ultrasonic probe apparatus 100. For example, if the depth to be measured is 15 cm and a velocity of ultrasound in the abdomen of a person is about 1500m/s, it takes $\frac{1}{5000}$ seconds for the ultrasonic signal to be transmitted and reflected and, thus, the ultrasound transceiver 110 may transmit the ultrasonic signals to acquire 5000 sheets of image data per second.

[0070] With reference to FIG. 4, the ultrasound transceiver 110 according to an exemplary embodiment may be detachably connected to a main body 408 of the ultrasonic probe apparatus 100 and may include a transducer 410 to generate unfocused ultrasonic signals as a plane wave and a transducer 420 to generate defocused ultrasonic signals as a spherical wave. Because the ultrasound transceiver 110 is detachable, a transducer 410 and a transducer 420 may be fitted alternately into the ultrasonic probe apparatus 100. Accordingly, the user

may alternately insert different types of transducers depending on the diagnostic part, i.e., application.

[0071] The converter **120** converts the analog ultrasonic data acquired in the ultrasound transceiver **110** into a digital form by using an ADC.

[0072] The processor **125** may control overall operation of the ultrasonic probe apparatus **100**. Particularly, the processor **125** may control ultrasonic signal transmission timing of the ultrasound transceiver **110** in order to change the first frame rate depending on the measuring depth which the user wants to measure.

[0073] Also, the processor **125** may perform various image processing operations in order to transmit the composite image data to the display apparatus **200**. Particularly, the processor **125** may include the image processor **130**, the combiner **140**, and the Doppler image processor **160** for the image processing operation.

[0074] The image processor **130** may generate a plurality of image data by image-processing the digital ultrasonic data, as for example, performing the demodulation and/or decimation.

[0075] The image processor **130** may edit the digital image data as image data for the same area in order to combine the entered image data. In detail, image data for different areas may be obtained depending on the type and steering angle of the ultrasound transceiver **110**.

[0076] With reference to FIG. 5, if unfocused ultrasonic signals are transmitted and received and the steering angle is perpendicular to the target (reference numeral **502**), the image processor **130** may obtain an image datum as illustrated by reference numeral **504**. If the unfocused ultrasonic signals are transmitted and received and the steering angle is bent to the right (reference numeral **506**), the image processor **130** may obtain an image datum as illustrated by reference numeral **508**. If the unfocused ultrasonic signals are transmitted and received and the steering angle is bent to the left (reference numeral **510**), the image processor **130** may obtain an image datum as illustrated by reference numeral **512**. If defocused ultrasonic signals are transmitted and received (reference numeral **514**), the image processor **130** may obtain an image datum as illustrated by reference numeral **516**.

[0077] However, if the image data for the different areas determined by the type of the ultrasonic signal and the steering angle are combined as obtained, the composite image data may contain a great amount of noise.

[0078] Accordingly, in order to combine image data for the same area, the image processor **130** may edit the image data so that only the respective dotted area of FIG. 5 is left and the remaining area is cut off.

[0079] On the other hand, in FIG. 5, the image data are edited based on when the steering angle is a right angle, but this is only an exemplary embodiment. The rest of the image data may be edited based on a first image datum for generating a composite image datum. For example, if a first composite image datum is generated by composing from first image datum to 100th image datum and a second composite image datum is generated by composing from 101st image datum to 200th image datum, the image processor **130** may edit from second image datum to the 100th image datum based on the first image datum, and may edit from 102nd image datum to the 200th image datum based on the 101st image datum.

[0080] The combiner **140** may generate a plurality of composite image data by composing the plurality of image data generated in the image processor **130**.

[0081] For example, the combiner **140** may combine the image data by considering the resolution of the composite image data. In detail, if the image data may be generated by using the defocused or unfocused ultrasounds, image data having a lot of frames may be obtained, but the resolution thereof may be lower than that of image data that are generated by using focused ultrasonic signals. Accordingly, the plurality of image data is combined so that the resolution of the image data may be increased and the signal-to-noise ratio thereof may be lowered. Accordingly, the combiner **140** may generate composite image data by composing image data of more than a predetermined frame. For example, the combiner **140** may generate the composite image data by composing image data of more than 100 frames. For example, the combiner **140** may determine the number of frames of the image data to be combined according to the user input.

[0082] Also, the combiner **140** may combine the image data by considering a frame rate that can be transmitted to the display apparatus **200**. For example, if the transmitter **150** can transmit less than 100 frames per second to the display apparatus **200**, the combiner **140** may combine the image data so that composite image data have a frame rate of less than 100 frames per second.

[0083] For example, the number of composite frames considering the resolution and the frame rate that can be transmitted to the display apparatus **200** may be determined independently. For example, if 5000 sheets of image data can be generated per second and 100 sheets of composite image data per second can be transmitted to the display apparatus **200**, the combiner **140** does not need to combine 50 sheets of image data into a single composite image datum. In other words, the combiner **140** may generate 50 sheets of composite image data in a way of composing from first image datum to 50th image datum into a first composite image datum and composing from 51st image datum to 100th image datum into a second composite image datum. However, this is only an exemplary embodiment. Alternatively, the combiner **140** may generate 50 sheets of composite image data in a way of composing from the first image datum to 100th image datum into a first composite image datum and composing from 51st image datum to 150th image datum into a second composite image datum.

[0084] As described above, because composite image data having a variety of resolution and frame rates can be generated by composing the image data in various ways, it can be applied to various applications.

[0085] The Doppler image processor **160** generates a plurality of Doppler images by performing Doppler processing for each of ultrasonic data of a plurality of digital signals. For example, the Doppler processing may include at least one of color Doppler processing, B-mode image processing, and spectral Doppler processing.

[0086] For example, the Doppler image processor **160** may generate dynamic images by using a Doppler filter.

[0087] The Doppler image processor **160** may output the processed Doppler image data to the combiner **140** which may compose the Doppler image data to have a predetermined frame, and transmit the image data to the display apparatus **200**.

[0088] As described above, the Doppler image data are generated, and then the generated Doppler image data may be combined and transmitted to the display apparatus **200**. How-

ever, this is only an exemplary embodiment. The Doppler image data may be generated by using the composite image data.

[0089] The transmitter **150** transmits at least one of the composite image data and the Doppler image data to the display apparatus **200**. For example, the transmitter **150** may transmit the composite image data or the Doppler image data in a wired or wireless manner. For example, the transmitter **150** may transmit the composite image data by using a wireless communication module such as WiFi, Bluetooth, UWB, WiGig, Zigbee, etc., and/or by using a wired communication module such as IEEE 1394, USB, etc.

[0090] Also, the transmitter **150** may transmit the composite image data or the Doppler image data to an external cloud server or a hospital server as well as the display apparatus **200**.

[0091] As described above, the combiner **140** generates the plurality of composite image data by composing the plurality of image data generated in the image processor **130**. However, this is only an exemplary embodiment. The image processor **130** may generate a plurality of composite image data by directly composing the plurality of image data without configuration of the combiner **140**. In other words, the image processor **130** and the combiner **140** may be implemented as a single hardware device.

[0092] Also, as described above, the combiner **140** combines the Doppler images outputted from the Doppler image processor **160**. However, this is only an exemplary embodiment.

[0093] As illustrated in FIG. 8, a separate Doppler image combiner **165** may combine the Doppler images. In detail, the Doppler image processor **160** generates the Doppler images by using the Doppler filter, and then outputs them to the Doppler image combiner **165**. The Doppler image combiner **165** may generate the composite Doppler images by composing the Doppler image data to have a predetermined frame, and may output the composite Doppler images to the transmitter **150**.

[0094] The wireless charger **170** charges the power of the ultrasonic probe apparatus **100** by using one of a magnetic induction method and a magnetic resonance method, and supplies the electric power to the power source **180**. For example, the magnetic induction method is technology in that magnetic field generated in the primary coil of a charging pad by causing current to flow through electromagnetic induction is induced to the secondary coil disposed on an object to be charged, thereby supplying current. The magnetic resonance method is technology in that the charging pad and the object to be charged are equipped with resonance coils having the same frequency and the power is sent with the frequency by using the resonance. For example, the wireless charger **170** may include a coil for wireless charging in the main body of the ultrasonic probe apparatus **100**.

[0095] The power source **180** supplies the electric power to each component of the ultrasonic probe apparatus **100** by using the power charged by the wireless charger **170**.

[0096] The detector **190** detects the user touch. For example, the detector **190** may include a sensor that can detect the user touch, as for example, at least one of an electromagnetic sensor, a gyro sensor, a pressure-sensitive sensor, etc. For example, the power source **180** may supply power to the ultrasonic probe apparatus **100** only if a user touch is detected by the detector **190**.

[0097] In addition, the ultrasonic probe apparatus **100** may include a motion processor (not illustrated), a voice processor (not illustrated), a self-charger (not illustrated), etc., to increase ease-of-use.

[0098] In detail, the motion processor may detect a user's motion and match a detected motion pattern to one of pre-stored motion patterns by comparing a detected motion with the pre-stored motion patterns. The motion processor may perform a function corresponding to the detected and matched motion pattern. For example, when the user shakes the ultrasonic probe apparatus **100** multiple times, the motion processor may perform a function corresponding to the shaking motion by detecting the user's motion.

[0099] The voice processor may detect a user's voice and search for a voice that matches the recognized voice among the pre-stored voices by comparing the recognized voice with the pre-stored voices. The voice processor may perform a function corresponding to the detected and matched voice. For example, when the user utters a voice command of "power-on," the voice processor may perform a function to turn on the power the ultrasonic probe apparatus **100** by recognizing the user's voice command.

[0100] The self-charger may charge the power by using super-capacitors for self-generation in the form of fiber. For example, the super-capacitors may be provided with clothing, gloves, aprons, etc.

[0101] By using the ultrasonic probe apparatus **100** as described above, the user will be able to receive the ultrasonic diagnostic service easier.

[0102] FIG. 6 is a block diagram schematically illustrating a configuration of a display apparatus **200** according to an exemplary embodiment. As illustrated in FIG. 6, a display apparatus **200** includes a transceiver **210**, an image processor **220**, a display **230**, an audio processor **240**, an audio output unit **250**, a controller **260**, and a user input unit **270**.

[0103] The transceiver **210** receives the composite image data or the Doppler image data from the ultrasonic probe apparatus **100**. Also, the transceiver **210** may transmit setting information (e.g., the resolution of image data, etc.) inputted by the user input unit **270** to the ultrasonic probe apparatus **100**.

[0104] The image processor **220** may perform signal processing to display the composite image data or the Doppler image data. Particularly, if the resolution of the input composite image data does not match the resolution of the display **230**, the image processor **220** may perform a scan conversion function to adjust the size of the composite image data.

[0105] The display **230** displays the composite image data or Doppler image data processed in the image processor **220**.

[0106] The audio processor **240** performs signal processing so that signals can be output through the audio output unit **250** based on the audio data received from the ultrasonic probe apparatus **100**. For example, the audio processor **240** may perform the signal processing by using Hilbert transform, etc.

[0107] The audio output unit **250** outputs audio data that is signal-processed in the audio processor **240**. For example, the audio output unit **250** may include a speaker.

[0108] The controller **260** controls overall operation of the display apparatus **200**. Particularly, the controller **260** may control the image processor **220** and the display **230** to process and display the composite image data by the user setting inputted through the user input unit **270**.

[0109] A control method of the ultrasonic probe apparatus **100** is described below in detail with reference to FIG. 7.

[0110] The ultrasonic probe apparatus **100** transmits unfocused or defocused ultrasonic signals to a diagnostic object (operation **S710**).

[0111] The ultrasonic probe apparatus **100** receives echo signals that are reflected by the diagnostic object (operation **S720**).

[0112] The ultrasonic probe apparatus **100** converts the echo signals from an analog form into digital signals (operation **S730**).

[0113] The ultrasonic probe apparatus **100** generates a plurality of image data by performing signal processing of the digital signals (operation **S740**).

[0114] The ultrasonic probe apparatus **100** generates composite image data by composing the plurality of image data (operation **S750**).

[0115] The ultrasonic probe apparatus **100** transmits the composite image data to the display apparatus **200** (operation **S760**).

[0116] By the control method of the ultrasonic probe apparatus as described above, the user will be able to receive the ultrasonic diagnostic service easier.

[0117] Program codes for performing a control method according to various exemplary embodiments as described above may be stored in a non-transitory computer-readable medium. The non-transitory computer-readable medium may be a medium that can store data in a semi-permanent manner and that can be read by devices. In detail, the various applications or programs may be stored in and provided with the non-transitory computer readable medium such as a CD, a DVD, a hard disc, a Blu-ray disc, an USB, a memory card, a ROM, etc.

[0118] The described-above exemplary embodiments and advantages are merely exemplary and are not to be construed as limiting. The present teaching can be readily applied to other types of apparatuses. The description of exemplary embodiments is intended to be illustrative, and not to limit the scope of the claims, and many alternatives, modifications, and variations will be apparent to those skilled in the art.

What is claimed is:

1. An ultrasonic probe apparatus comprising:
 - an ultrasound transceiver adapted to transmit unfocused or defocused ultrasonic signals to an object and receive reflected ultrasonic echo signals having a first frame rate;
 - a converter adapted to convert the ultrasonic echo signals into digital signals;
 - an image processor adapted to generate a plurality of image data by processing the digital signals;
 - a combiner adapted to combine the plurality of image data having a first frame rate into a plurality of composite image data having a second frame rate; and
 - a transmitter adapted to transmit the plurality of composite image data having the second frame rate to an external display apparatus.
2. The ultrasonic probe apparatus of claim **1**, wherein the image processor comprises a Doppler image processor adapted to generate a plurality of Doppler images by performing Doppler processing on the digital signals.
3. The ultrasonic probe apparatus of claim **2**, wherein the Doppler processing comprises at least one of color Doppler processing, B-mode image processing, and spectral Doppler processing.

4. The ultrasonic probe apparatus of claim **1**, wherein the image data having different sizes are generated due to receiving the ultrasonic echo signals that are reflected in response to transmitting defocused ultrasonic signals or to changing a steering angle of the ultrasonic probe apparatus, and the image processor edits the image data having the different sizes into the image data having a predetermined size.
5. The ultrasonic probe apparatus of claim **1**, wherein the first frame rate is determined depending on a measuring depth to be measured by using the ultrasonic probe apparatus.
6. The ultrasonic probe apparatus of claim **1**, wherein the second frame rate is determined depending on a frame rate which the transmitter can transmit.
7. The ultrasonic probe apparatus of claim **1**, wherein the transmitter transmits the plurality of composite image data wirelessly to the external display apparatus.
8. The ultrasonic probe apparatus of claim **1**, wherein the ultrasound transceiver is detachable from the ultrasonic probe apparatus.
9. The ultrasonic probe apparatus of claim **1**, further comprising:
 - a wireless charger adapted to charge power of the ultrasonic probe apparatus by using one of a magnetic induction method and a magnetic resonance method.
10. The ultrasonic probe apparatus of claim **1**, further comprising:
 - a detector adapted to detect a user touch; and
 - a power source adapted to supply power to the ultrasonic probe apparatus when the user touch is detected.
11. An ultrasonic imaging method comprising:
 - transmitting unfocused or defocused ultrasonic signals to an object;
 - receiving reflected ultrasonic echo signals having a first frame rate;
 - converting the received ultrasonic echo signals into digital signals;
 - generating a plurality of image data by processing the converted digital signals;
 - combining the plurality of image data having the first frame rate into a plurality of composite image data having a second frame rate; and
 - transmitting the plurality of composite image data having the second frame rate to an external display apparatus.
12. The ultrasonic imaging method of claim **11**, wherein the generating the plurality of image data comprises generating a plurality of Doppler images by performing Doppler processing on the converted digital signals.
13. The ultrasonic imaging method of claim **12**, wherein the Doppler processing comprises at least one of color Doppler processing, B-mode image processing, and spectral Doppler processing.
14. The ultrasonic imaging method of claim **11**, wherein the generating the image data comprises generating the image data having different sizes due to receiving the ultrasonic echo signals that are reflected in response to transmitting the defocused ultrasonic signals or changing a steering angle of an ultrasonic probe, and editing the image data having the different sizes into the image data having a predetermined size.

15. The ultrasonic imaging method of claim 11, wherein the first frame rate is determined depending on a measuring depth of an ultrasound.
16. The ultrasonic imaging method of claim 11, wherein the second frame rate is determined depending on a frame rate which can be transmitted to the external display apparatus.
17. The ultrasonic imaging method of claim 11, wherein transmitting the plurality of composite image data comprises transmitting the plurality of composite image data wirelessly.
18. The ultrasonic imaging method of claim 11, further comprising:
charging power of an ultrasonic probe adapted to transmit and receive ultrasonic waves, by using one of a magnetic induction method and a magnetic resonance method.
19. The ultrasonic imaging method of claim 11, further comprising:
detecting a user touch; and
supplying electric power signal to an ultrasonic probe adapted to transmit and receive ultrasonic waves when the user touch is detected.

* * * * *

专利名称(译)	超声波探头装置及其控制方法		
公开(公告)号	US20140148699A1	公开(公告)日	2014-05-29
申请号	US14/092193	申请日	2013-11-27
[标]申请(专利权)人(译)	三星电子株式会社		
申请(专利权)人(译)	SAMSUNG ELECTRONICS CO. , LTD.		
当前申请(专利权)人(译)	SAMSUNG ELECTRONICS CO. , LTD.		
[标]发明人	SHIM HWAN KOH HYUN WOO KIM SEOUNG HUN KIM YOUNG TAE		
发明人	SHIM, HWAN KOH, HYUN-WOO KIM, SEOUNG-HUN KIM, YOUNG-TAE		
IPC分类号	A61B8/08		
CPC分类号	G01S15/8979 G01S7/52034 A61B8/4427 A61B8/4472 A61B8/4411 A61B8/488 G01S15/8995 A61B8/5246 G01S7/52096 A61B8/565 G01S7/5208 G01S7/52079 A61B8/56 G01S7/003 A61B8/5253		
优先权	1020120137219 2012-11-29 KR		
其他公开文献	US20170340313A9		
外部链接	Espacenet USPTO		

摘要(译)

超声波探头装置包括超声波收发器，其适于接收在发射具有第一帧速率的未聚焦或散焦的超声波信号之后反射的超声回波信号；转换器，适于将超声波收发器接收的超声回波信号转换成数字信号；图像处理器，适于通过处理数字信号产生多个图像数据；组合器，适于将具有第一帧速率的多个图像数据组合成具有第二帧速率的多个合成图像数据；发送器，适于发送具有第二帧速率的多个合成图像数据。

