



(19) **United States**

(12) **Patent Application Publication** (10) **Pub. No.: US 2007/0167763 A1**

**HYUN**

(43) **Pub. Date:**

**Jul. 19, 2007**

(54) **APPARATUS AND METHOD FOR DISPLAYING AN ULTRASOUND IMAGE**

(57) **ABSTRACT**

(75) Inventor: **Dong Gyu HYUN**, Seoul (KR)

Correspondence Address:

**OBLON, SPIVAK, MCCLELLAND, MAIER & NEUSTADT, P.C.  
1940 DUKE STREET  
ALEXANDRIA, VA 22314 (US)**

(73) Assignee: **Medison Co.,Ltd.**, Hongchun-gun (KR)

(21) Appl. No.: **11/566,851**

(22) Filed: **Dec. 5, 2006**

(30) **Foreign Application Priority Data**

Dec. 6, 2005 (KR)..... 10-2005-0117909

**Publication Classification**

(51) **Int. Cl.**  
**A61B 8/00** (2006.01)

(52) **U.S. Cl.** ..... **600/437**

Embodiments of the present invention may provide an apparatus and a method for displaying a 3-dimensional ultrasound image formed based on 2-dimensional ultrasound images. The method for displaying an ultrasound image, comprises: a) forming and storing a plurality of sequential 2-dimensional ultrasound images based on ultrasound echo signals reflected from a target object, each of said sequential 2-dimensional ultrasound images being assigned a serial number; b) selecting N numbers of 2-dimensional ultrasound images having consecutive serial numbers; c) superposing the N number of 2-dimensional ultrasound images to form a 3-dimensional ultrasound image; d) forming a flow direction marker indicating a first 2-dimensional ultrasound image from the N numbers of 2-dimensional ultrasound images; e) displaying the 3-dimensional ultrasound image together with the flow direction marker on a screen; f) removing the first 2-dimensional ultrasound image from the N numbers of 2-dimensional ultrasound images; g) selecting a (N+1)<sup>th</sup> 2-dimensional ultrasound image and superposing the selected 2-dimensional ultrasound image to the superposed 2-dimensional ultrasound images; and h) repeating the steps c) to h) as many as a predetermined number.

100

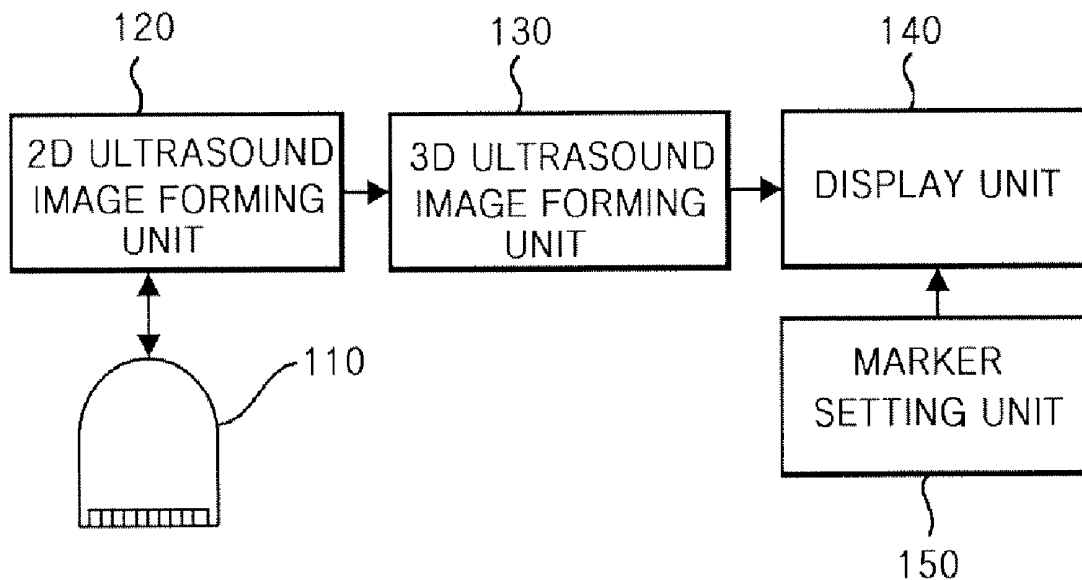

FIG. 1

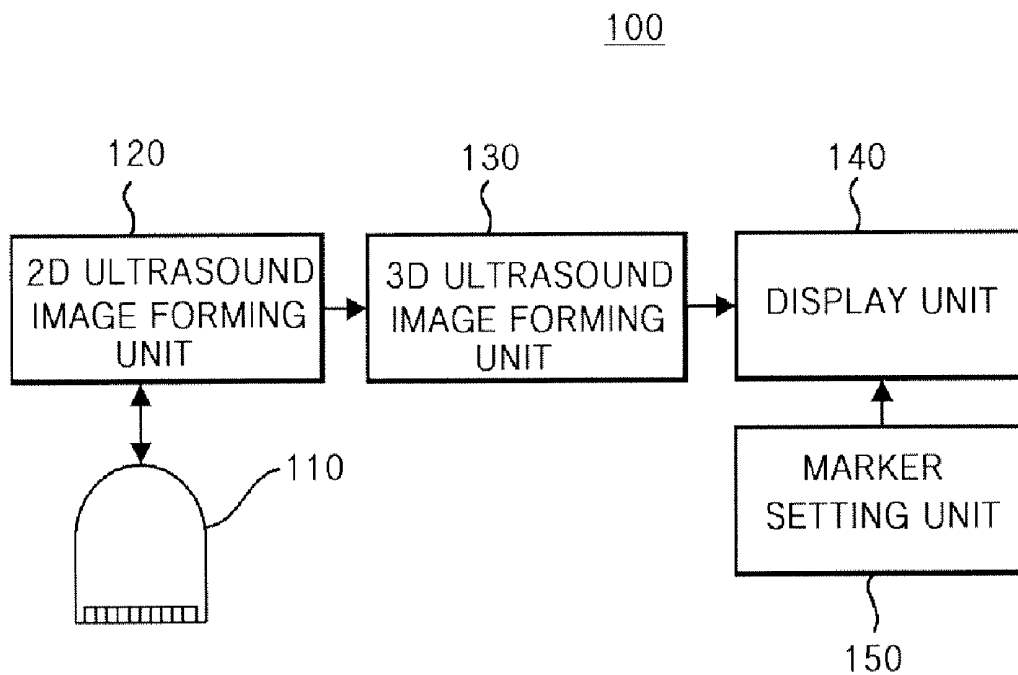

FIG. 2

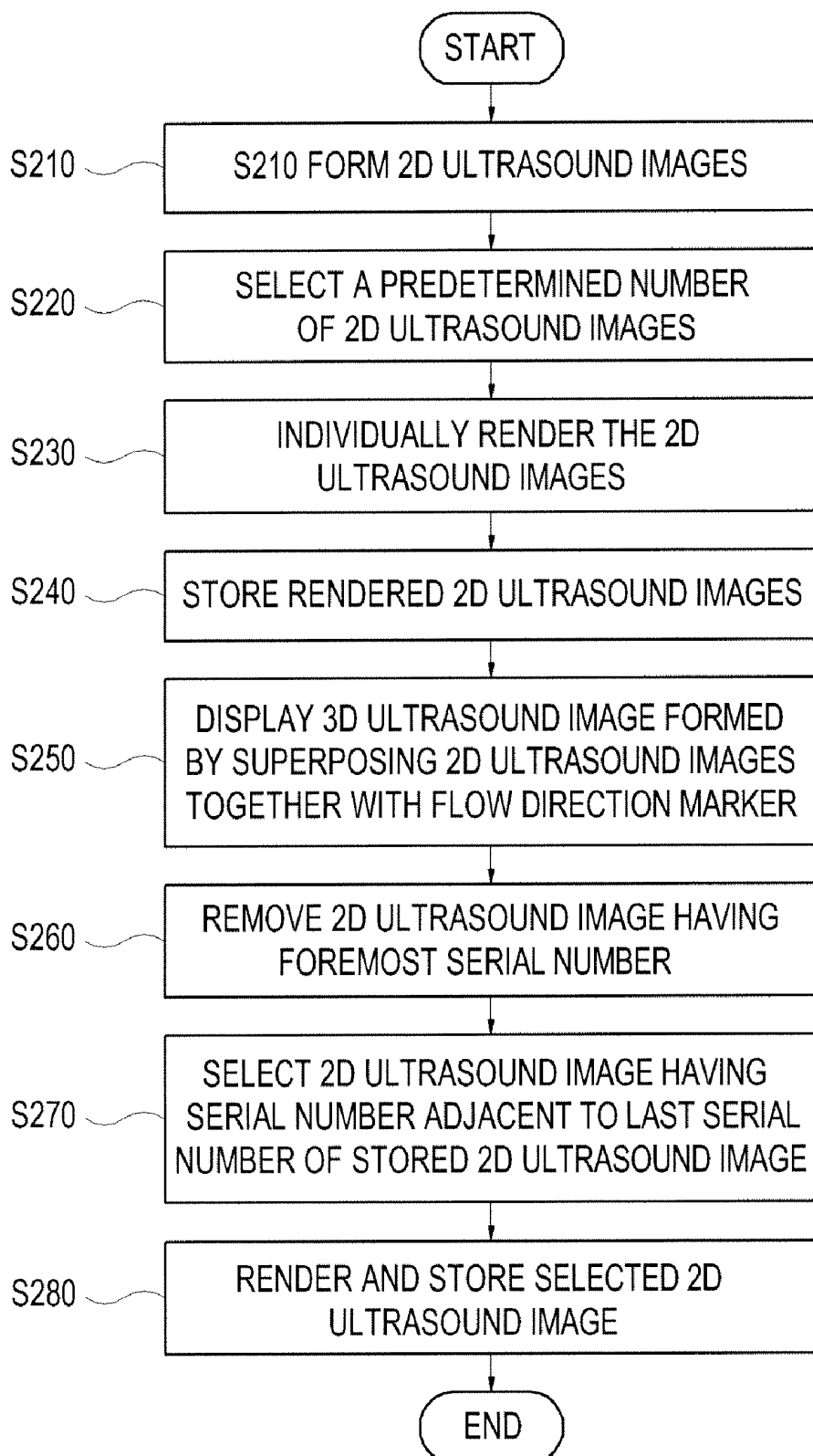

FIG. 3

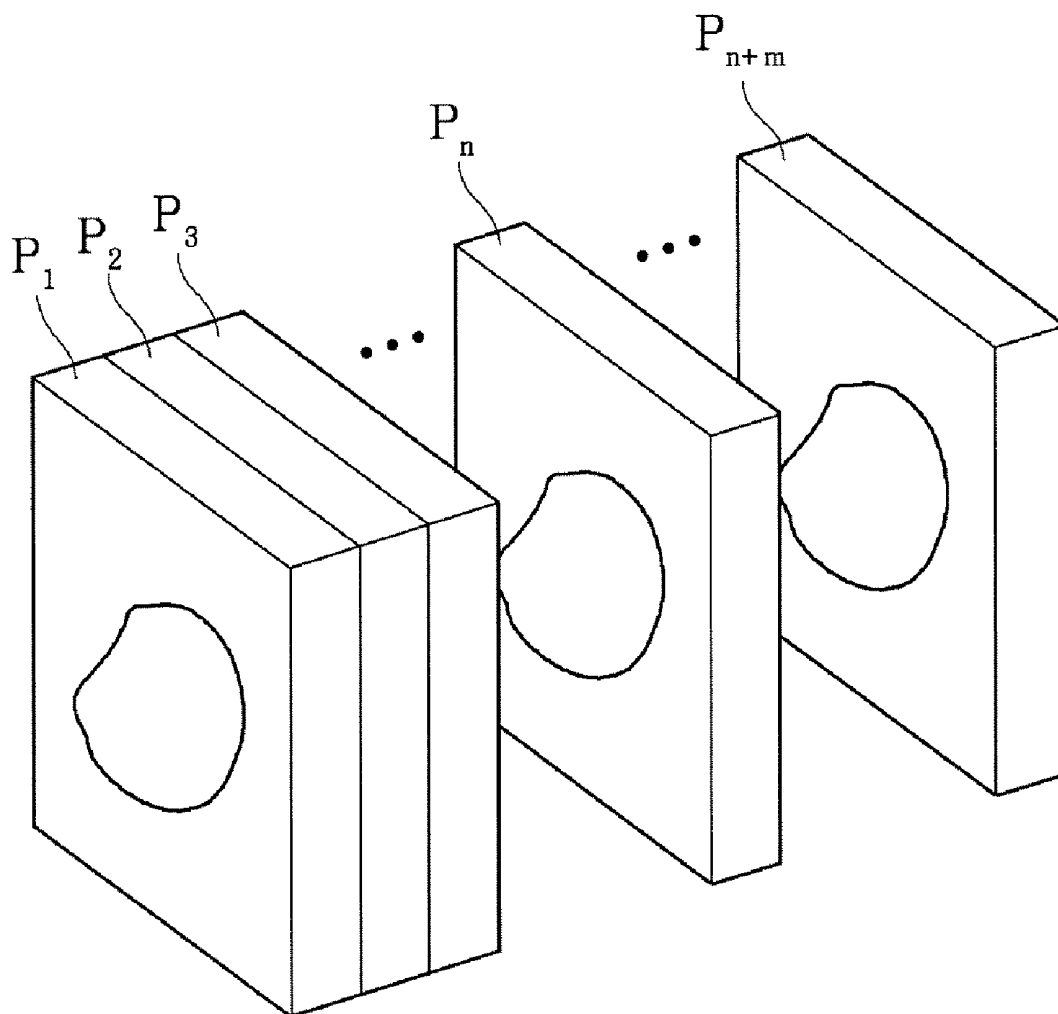

FIG. 4

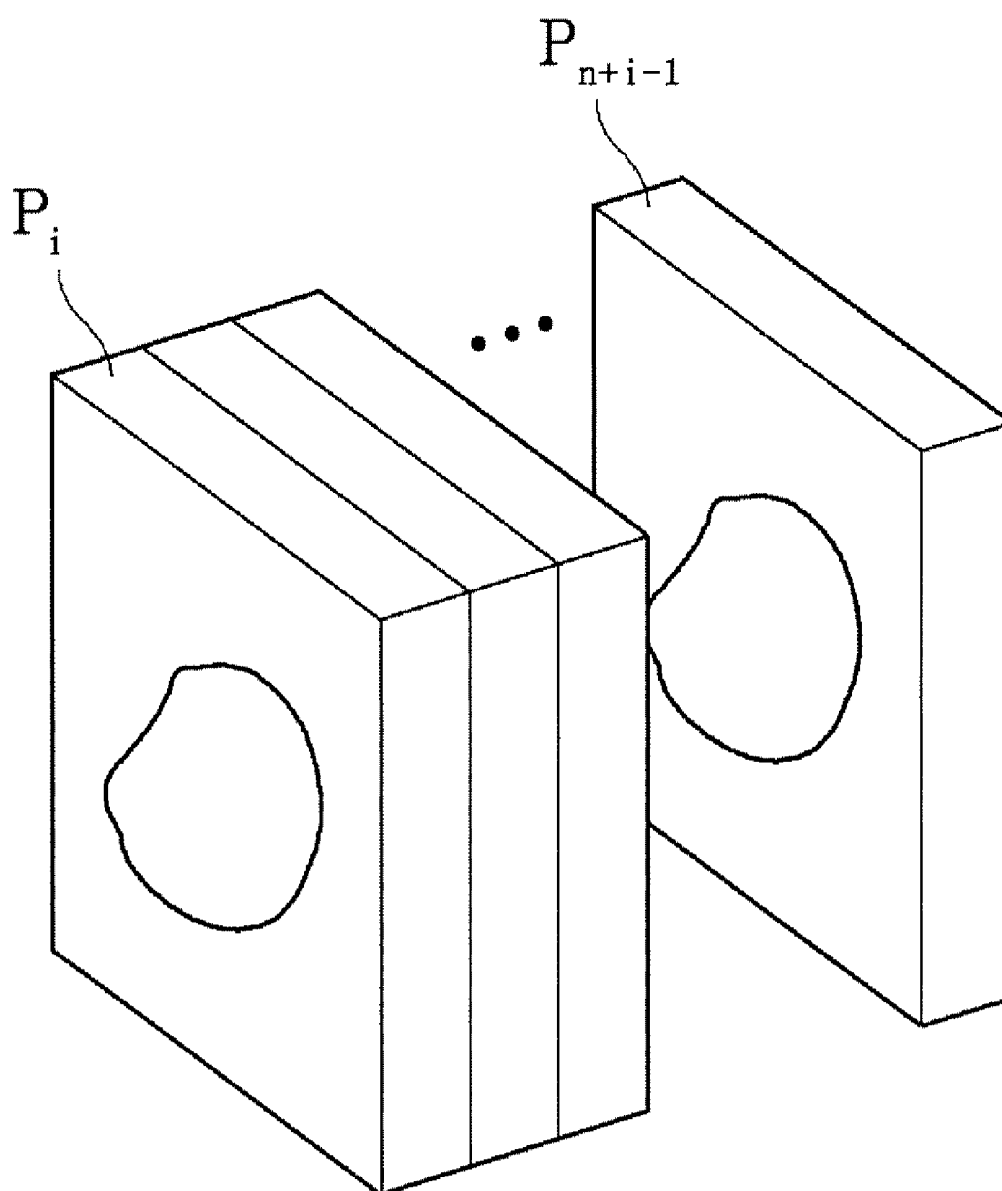

FIG. 5

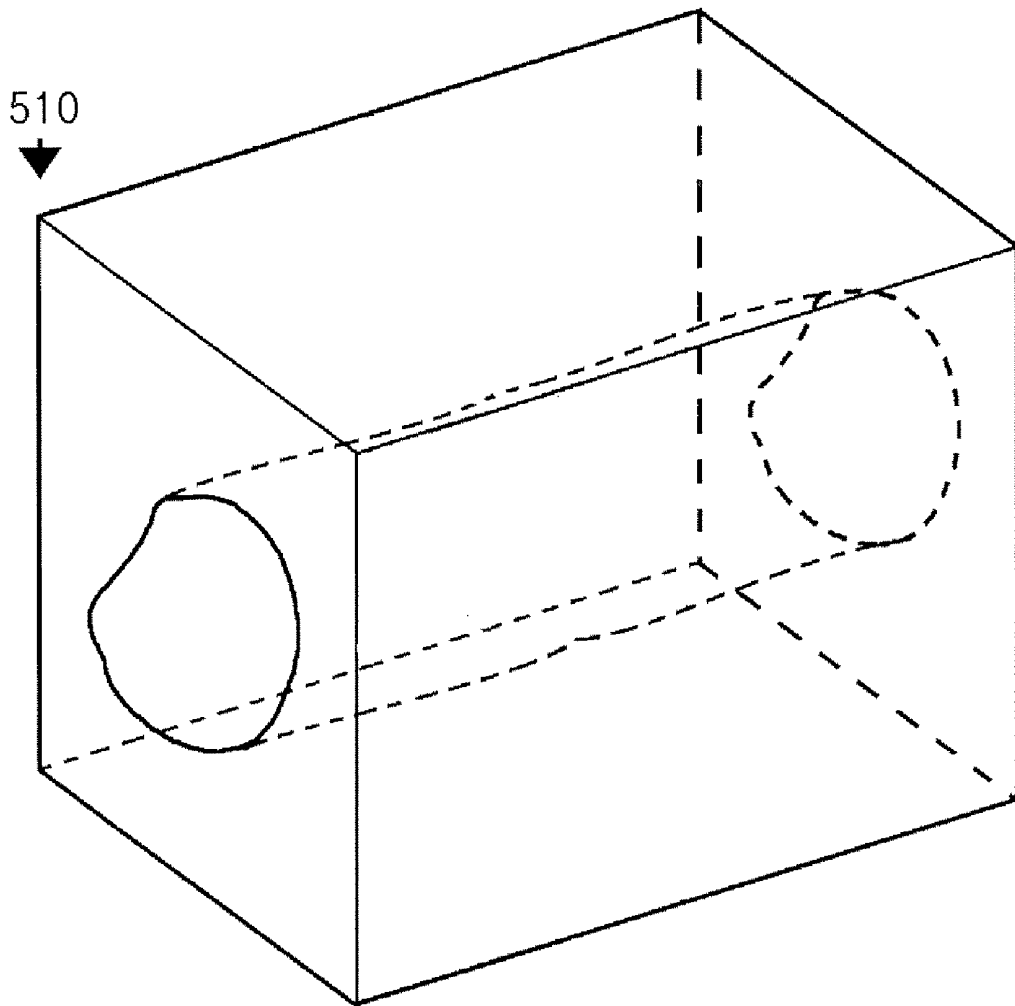

FIG. 6

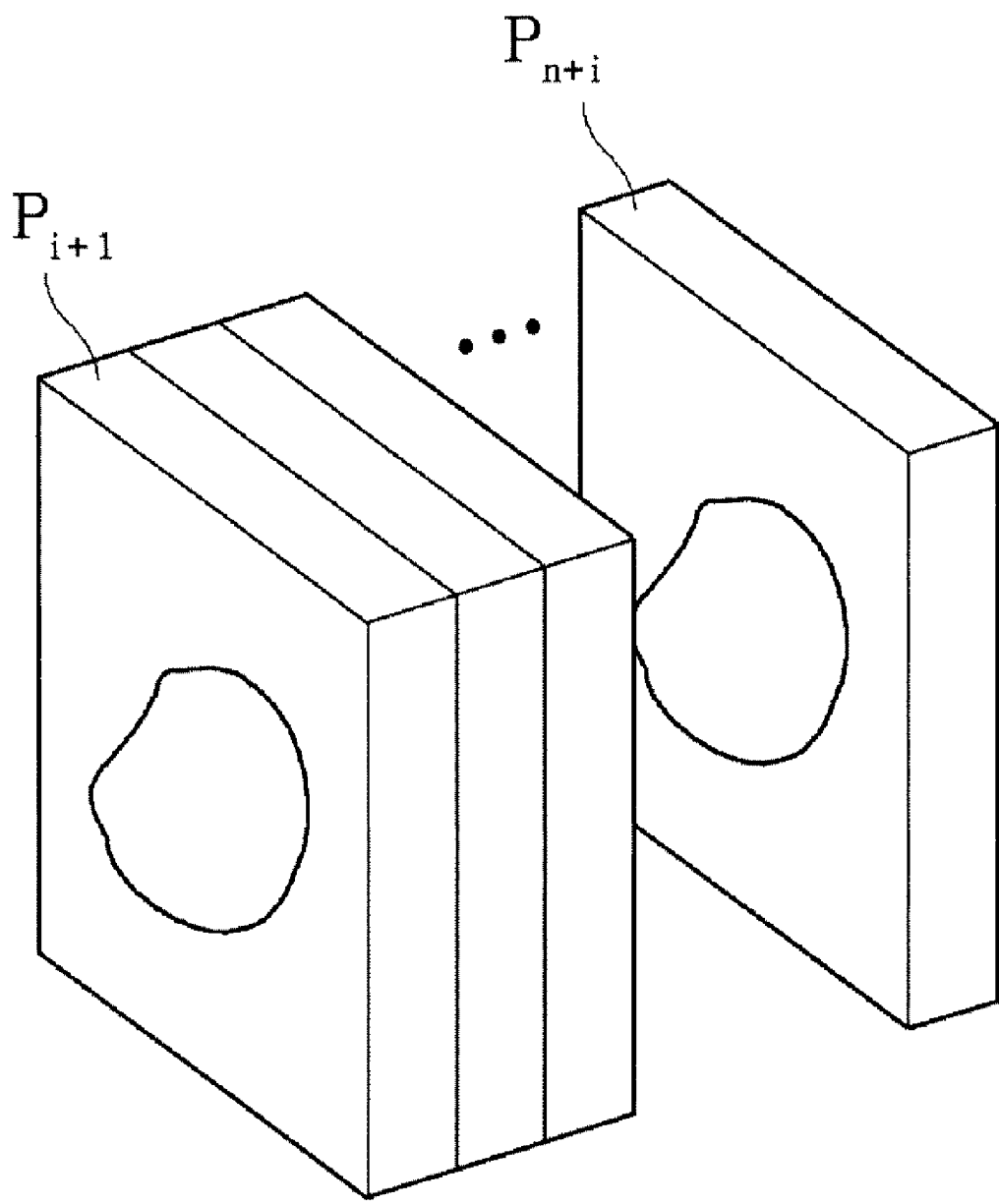

FIG. 7

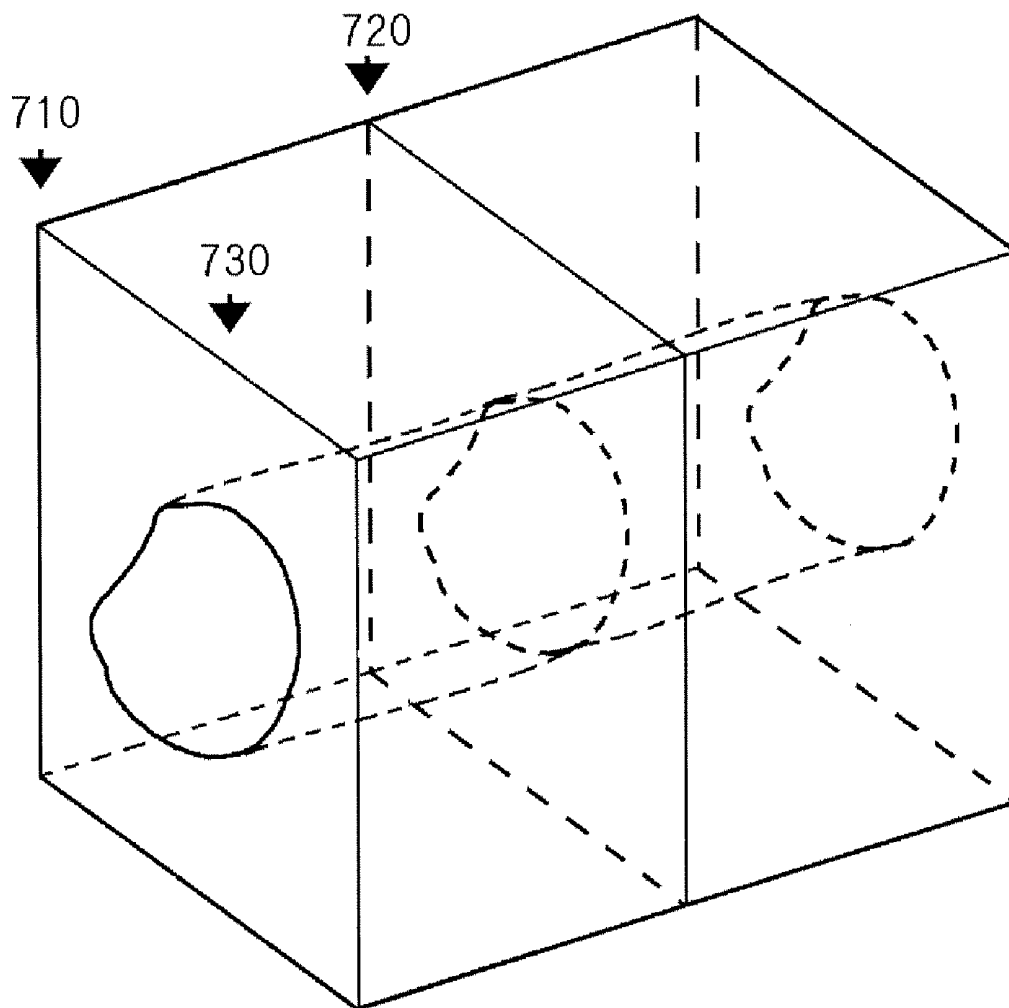

FIG. 8

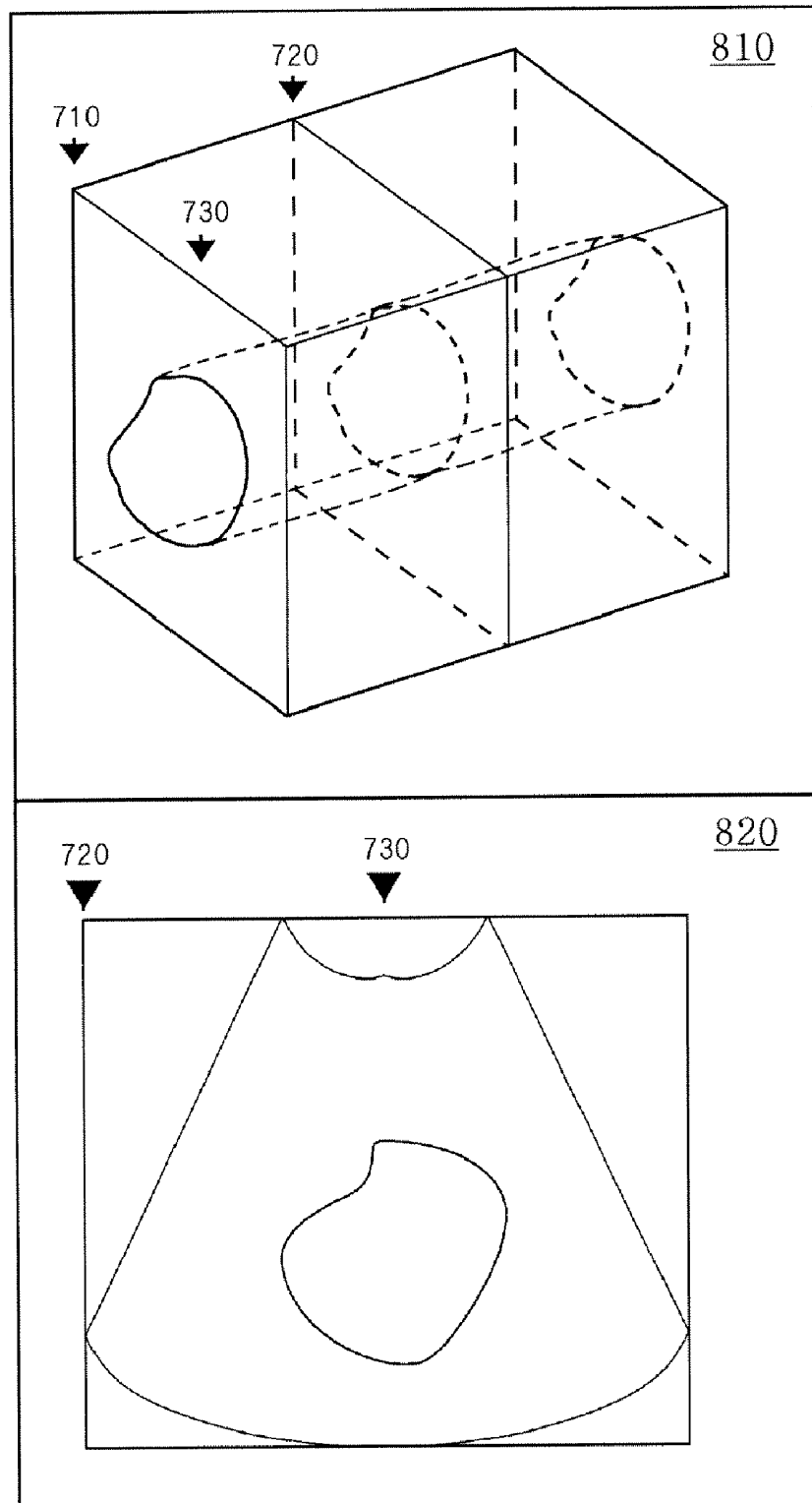

FIG. 9

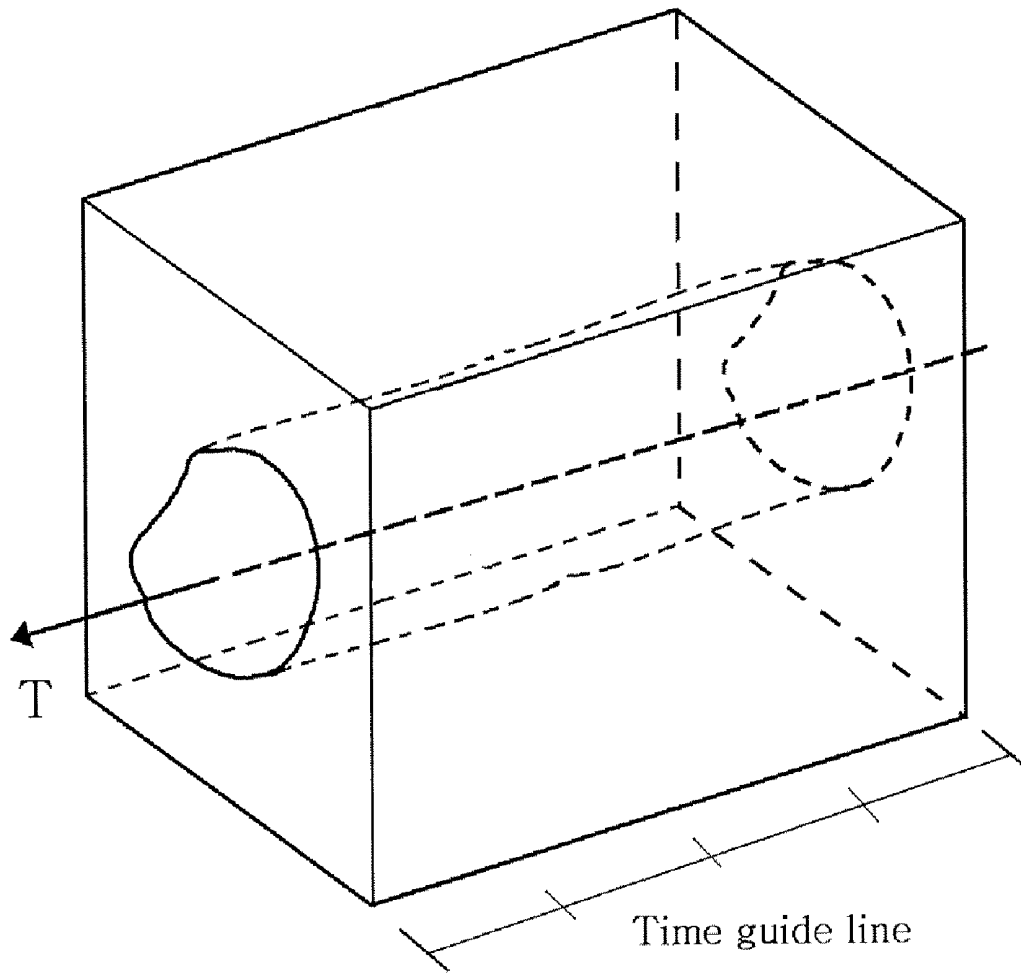

FIG. 10

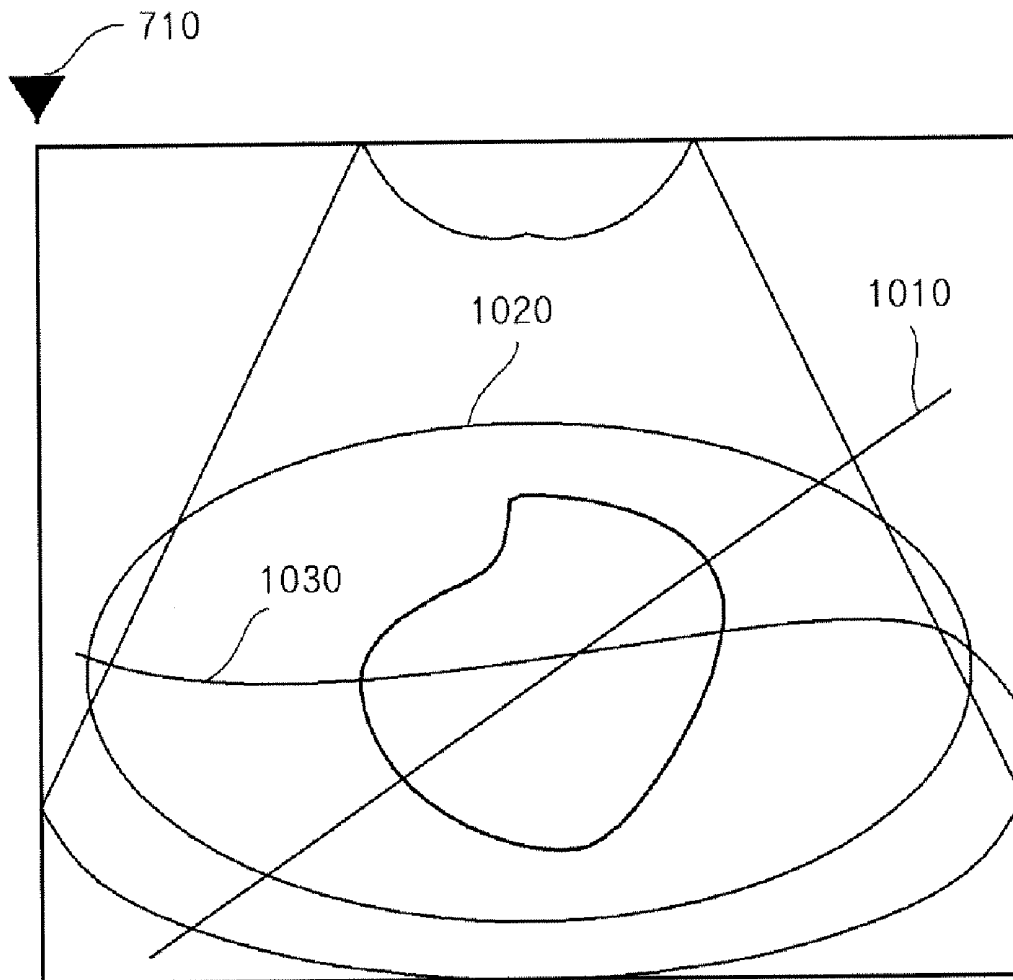

FIG. 11

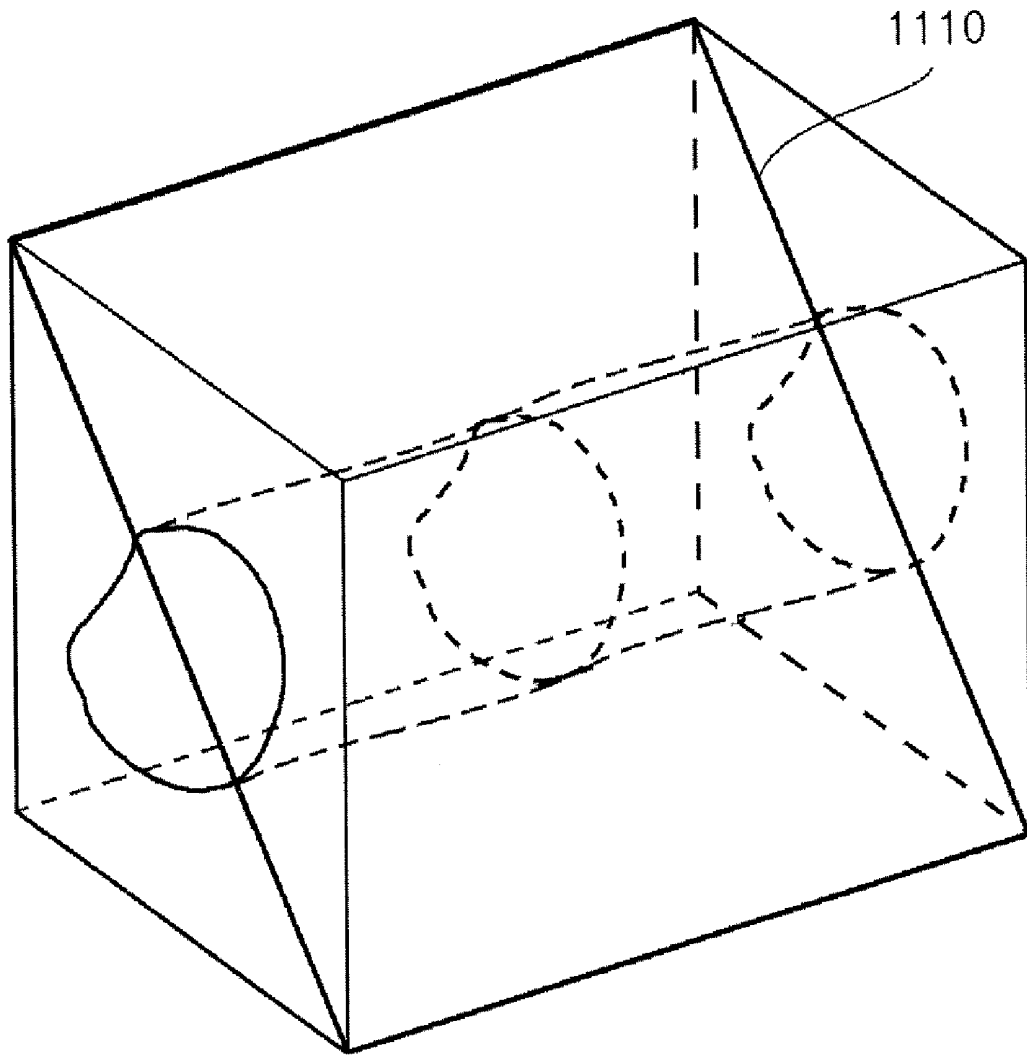
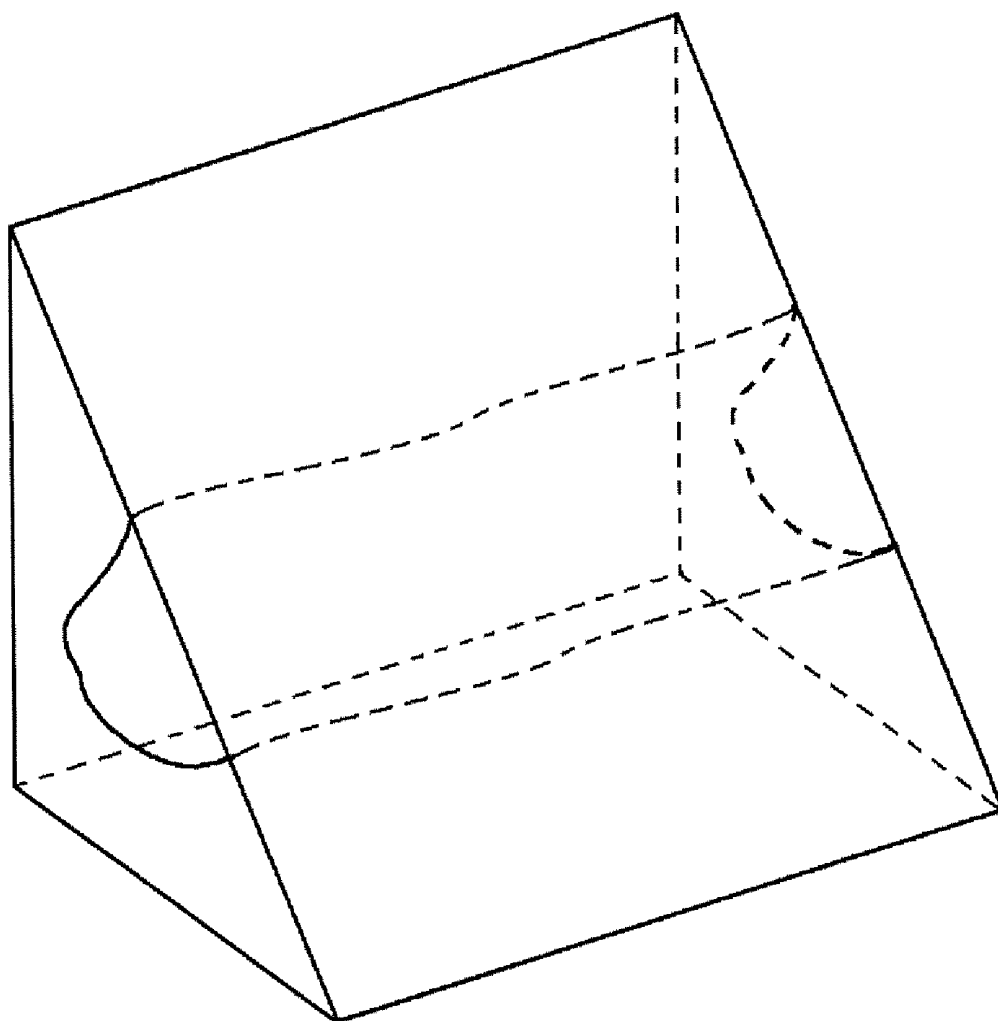

FIG. 12



## APPARATUS AND METHOD FOR DISPLAYING AN ULTRASOUND IMAGE

[0001] The present application claims priority from Korean Patent Application 10-2005-0117909 filed on Dec. 6, 2005, the entire subject matter of which is incorporated herein by reference.

### BACKGROUND

[0002] 1. Field

[0003] The present invention generally relates to ultrasound image processing, and more particularly to an apparatus and method for displaying a 3-dimensional ultrasound image formed based on 2-dimensional ultrasound images.

[0004] 2. Background

[0005] An ultrasound diagnostic system has become an important and popular diagnostic tool since it has a wide range of applications. Specifically, due to its non-invasive and non-destructive nature, the ultrasound diagnostic system has been extensively used in the medical profession. Modern high-performance ultrasound diagnostic systems and techniques are commonly used to produce two or three-dimensional diagnostic images of internal features of an object (e.g., human organs).

[0006] The ultrasound diagnostic system generally uses a wide bandwidth transducer to transmit and receive ultrasound signals. The ultrasound diagnostic system forms images of human internal tissues by electrically exciting an acoustic transducer element or an array of acoustic transducer elements to generate ultrasound signals that travel into the body. The ultrasound signals produce ultrasound echo signals since they are reflected from body tissues, which appear as discontinuities to the propagating ultrasound signals. Various ultrasound echo signals return to the transducer element and are converted into electrical signals, which are amplified and processed to produce ultrasound data for an image of the tissues. The ultrasound diagnostic system is very important in the medical field since it provides physicians with real-time and high-resolution images of human internal features without the need for invasive observation techniques such as surgery.

[0007] Generally, the ultrasound diagnostic system obtains raw 3D data (e.g., data on a coordinate system (x, y, z)) through a 3D probe regardless of acquisition time by stacking frames over one another at a uniform time interval to form consecutive frames. It then processes the consecutive frames using a 3D rendering technique, thereby producing 3D static images. By using the static 3D images for ultrasound diagnostic purposes, one may easily and accurately observe, diagnose and treat the internal state of a human body without performing any complicated procedures associated with invasive operations. Thus, the static 3D images are widely used. However, the static 3D images are not useful in observing a moving target object in real time, such as a fetus in the uterus.

[0008] In order to overcome this shortcoming, a live 3D imaging method and apparatus for providing a live 3D moving image (rather than static 3D images) have been developed. However, a 3-dimensional probe for forming a live 3D ultrasound image is disadvantageous since it is very complex and expensive.

[0009] Accordingly, it is highly desirable to form a 3-dimensional ultrasound image without using the 3-dimensional probe.

### BRIEF DESCRIPTION OF THE DRAWINGS

[0010] Arrangements and embodiments may be described in detail with reference to the following drawings in which like reference numerals refer to like elements and wherein:

[0011] FIG. 1 is a schematic block diagram illustrating an ultrasound diagnostic device constructed in accordance with one embodiment of the present invention;

[0012] FIG. 2 is a flowchart illustrating a method for displaying an ultrasound image in accordance with one embodiment of the present invention;

[0013] FIG. 3 is a schematic diagram illustrating a plurality of 2-dimensional ultrasound images;

[0014] FIG. 4 is a schematic diagram illustrating a predetermined number of 2-dimensional ultrasound images to form a 3-dimensional ultrasound image;

[0015] FIG. 5 is a schematic diagram illustrating a 3-dimensional ultrasound image formed by superposing the predetermined number of 2-dimensional ultrasound images in accordance with one embodiment of the present invention;

[0016] FIG. 6 is a schematic diagram illustrating superposed 2-dimensional ultrasound images;

[0017] FIG. 7 is a schematic diagram illustrating an example of setting a flow direction marker and a selection marker on a 3-dimensional ultrasound image in accordance with one embodiment of the present invention;

[0018] FIG. 8 is a schematic diagram illustrating an example of displaying a 3-dimensional ultrasound image and a 2-dimensional ultrasound image selected by a selection marker;

[0019] FIG. 9 is a schematic diagram illustrating an example of indicating a rotation axis and a time guide line on a 3-dimensional ultrasound image;

[0020] FIG. 10 is a schematic diagram illustrating examples of various cutting markers set on a 3-dimensional ultrasound image;

[0021] FIG. 11 is a schematic diagram illustrating an example of a cutting marker set on a 3-dimensional ultrasound image; and

[0022] FIG. 12 is a schematic diagram illustrating a cross-sectional plane formed along a cutting marker.

### DETAILED DESCRIPTION

[0023] A detailed description may be provided with reference to the accompanying drawings. One of ordinary skill in the art may realize that the following description is illustrative only and is not in any way limiting. Other embodiments of the present invention may readily suggest themselves to such skilled persons having the benefit of this disclosure.

[0024] FIG. 1 is a block diagram showing an ultrasound diagnostic device constructed in accordance with the present invention. As shown in FIG. 1, the ultrasound diagnostic

device **100** includes a probe **110**, a 2-dimensional ultrasound image forming unit **120**, a 3-dimensional ultrasound image forming unit **130**, a display unit **140** and a marker setting unit **150**. The probe **110** transmits ultrasound signals to a target object and receives ultrasound echo signals. The probe **110** may be any probe capable of acquiring a 2-dimensional ultrasound image.

[0025] The 2-dimensional ultrasound image forming unit **120** forms a plurality of 2-dimensional ultrasound images having serial numbers based on the ultrasound echo signals. The 2-dimensional ultrasound images may be one of B-mode images, Doppler images and color-mode images. The serial number may be set in an order of acquisition time of the 2-dimensional ultrasound images.

[0026] The 3-dimensional ultrasound image forming unit **130** forms a 3-dimensional ultrasound image based on the plurality of 2-dimensional ultrasound images. The 3-dimensional ultrasound image forming unit **130** selects a predetermined number of 2-dimensional ultrasound images and individually renders the selected 2-dimensional ultrasound images. The rendered 2-dimensional ultrasound images are sequentially buffered and then superposed, thereby forming the 3-dimensional ultrasound image.

[0027] The 3-dimensional ultrasound image forming unit **130** may provide a transparent 3-dimensional ultrasound image obtained by an appropriate transparency treatment for showing a volume of interest (VOI) in the 3-dimensional ultrasound image. The 3-dimensional ultrasound image or the transparent 3-dimensional ultrasound image formed in the 3-dimensional ultrasound image forming unit **130** is transmitted to the display unit and then displayed on a screen of the display unit **140**.

[0028] The marker setting unit **150** sets a plurality of markers on the 3-dimensional ultrasound image displayed on the screen of the display unit **140**. The markers may represent a rotation axis of the 3-dimensional ultrasound image, a direction along which the 2-dimensional ultrasound images are superposed, and the like. The markers may be set by using control keys provided on a control panel (not shown) of the ultrasound diagnostic device.

[0029] Hereinafter, a method for displaying an ultrasound image will be described in detail with reference to FIGS. 2 to 6. FIG. 2 is a flowchart illustrating a method for displaying the ultrasound image in accordance with an embodiment of the present invention.

[0030] Referring to FIG. 2, the 2-dimensional ultrasound image forming unit **120** forms a plurality of 2-dimensional ultrasound images in real time based on the ultrasound echo signals, which are reflected from a predetermined region of a target object as shown in FIG. 3 at step S210. Serial numbers P1, P2, . . . may be assigned to each 2-dimensional ultrasound image. The serial numbers assigned to the 2-dimensional ultrasound images may be set in an order of acquisition time of the 2-dimensional ultrasound images. The 3-dimensional ultrasound image forming unit **130** selects a predetermined number of 2-dimensional ultrasound images having consecutive serial numbers among the plurality of 2-dimensional ultrasound images at step S220.

[0031] The selected 2-dimensional ultrasound images are individually rendered at step S230. Then, the rendered 2-dimensional ultrasound images are stored at step S240.

Thereafter, the stored 2-dimensional ultrasound images are superposed to thereby form and display a 3-dimensional ultrasound image. The 3-dimensional ultrasound image may be displayed together with a flow direction marker indicating a position of a preset 2-dimensional ultrasound image at step S250. FIG. 5 schematically shows a 3-dimensional ultrasound image displayed on a screen. The flow direction marker **510** may be set to indicate a 2-dimensional ultrasound image having a foremost serial number.

[0032] Subsequently, a 2-dimensional ultrasound image having a foremost serial number is removed from the stored 2-dimensional ultrasound images at step S260. Then, a 2-dimensional ultrasound image having a serial number adjacent to the last serial number of the stored 2-dimensional ultrasound images is selected at step S270. The 2-dimensional ultrasound image selected at step S270 is rendered and stored at step S280.

[0033] FIG. 6 is a schematic diagram showing the superposed 2-dimensional ultrasound images. The 2-dimensional ultrasound image having the foremost serial number  $P_i$  is removed and the 2-dimensional ultrasound image having a serial number  $P_{n+i}$  adjacent to the last serial number of the stored 2-dimensional ultrasound images is superposed. Steps S240 to S280 are repeatedly performed for the plurality of 2-dimensional ultrasound images formed in the 2-dimensional ultrasound image forming unit, thereby forming and displaying 3-dimensional ultrasound sound images in real time.

[0034] Various types of markers may be set together with the flow direction marker on the 3-dimensional ultrasound image displayed on a screen of the display unit **140**. The markers may be used to indicate a viewing angle of the 3-dimensional ultrasound image, a position for selecting an arbitrary frame from the frames consisting of the 3-dimensional ultrasound image and a cross-sectional view of the 3-dimensional ultrasound image.

[0035] An inverse mode may be applied to the 3-dimensional ultrasound image formed according to the embodiment of the present invention to make the walls of blood vessels or a heart invisible in the 3-dimensional ultrasound image. This is so that a change in the amount of blood in the blood vessel or the heart according to a time change can be easily observed.

[0036] FIG. 7 is a schematic diagram illustrating an example of setting a flow direction marker **710** and a selection marker **720** on the 3-dimensional ultrasound image in accordance with the embodiment of the present invention. As shown in FIG. 7, the flow direction marker **710** indicating a 2-dimensional ultrasound image having a foremost serial number and the selection marker **720** indicating an arbitrary 2-dimensional ultrasound image are set on the 3-dimensional ultrasound image. A direction, along which the 2-dimensional ultrasound images are superposed, may be identified through the flow direction marker **710**. If the 2-dimensional ultrasound image having the foremost serial number is removed from the 3-dimensional ultrasound image, then the flow direction marker **710** automatically indicates a 2-dimensional ultrasound image having a next serial number.

[0037] The selection marker **720** may be replaced with the flow direction marker **710**. For example, if a user inputs a

setup instruction of the selection marker, then the marker setting unit 150 sets the flow direction marker 710 displayed on the 3-dimensional ultrasound image as a selection marker 720. If the user inputs a moving instruction of the selection marker 720, then the marker setting unit 150 moves the position of the selection marker 720 on the 3-dimensional ultrasound image in response to the moving instruction. Further, the screen of the display unit 140 is divided into a first region 810 and a second region 820, as shown in FIG. 8. The 3-dimensional ultrasound image is displayed on the first region 810 and a 2-dimensional ultrasound image position at the moved selection marker 720 is displayed on the second region 820. Further, an image direction marker 730 indicating a direction of a target object in the 3-dimensional ultrasound image may be displayed.

[0038] FIG. 9 is a schematic diagram illustrating an example of setting a rotation marker on the 3-dimensional ultrasound image in accordance with the embodiment of the present invention. A time axis may be used as a rotation marker T. The rotation axis T is used to rotate the 3-dimensional ultrasound image, thereby displaying the 3-dimensional ultrasound image in various directions. Also, if the rotation axis corresponds to the time axis, then a time guide line indication for a moving period of the target object such as a heart may be provided on the screen. It is preferable that the time guide line is displayed in parallel with an array direction of the 2-dimensional ultrasound images.

[0039] FIG. 10 is a schematic diagram showing an example of setting various cutting markers for showing cross-sectional views of the 3-dimensional ultrasound image. If the user inputs a cutting marker setting instruction, the marker setting unit 160 sets the cutting marker on the 2-dimensional ultrasound image displayed on the second region 820 so that the 2-dimensional ultrasound image is divided into at least two regions. Thereafter, if the user selects one of the regions by using an indicator (not shown), a cross-sectional plane image corresponding to the selected region is displayed on the screen. As shown in FIG. 10, the cutting marker may include a line cutting marker 1010, a curve cutting marker 1020, a free line cutting marker 1030 and the like.

[0040] FIG. 11 shows an example of indicating a line cutting marker 1110 on the 3-dimensional ultrasound image. FIG. 12 shows a cross-sectional plane obtained by cutting the 3-dimensional ultrasound image along the line cutting marker 1110.

[0041] As mentioned above, the 3-dimensional ultrasound image is formed by superposing the 2-dimensional ultrasound images in accordance with one embodiment of the present invention. This is so that the 3-dimensional ultrasound image can be provided without using an expensive 3-dimensional probe. Also, as the 3-dimensional ultrasound image is formed by individually rendering the 2-dimensional ultrasound images, a time for forming the 3-dimensional ultrasound image can be reduced, thereby providing the 3-dimensional ultrasound image in real time.

[0042] A method for displaying an ultrasound image, comprises: a) forming and storing a plurality of sequential 2-dimensional ultrasound images based on ultrasound echo signals reflected from a target object, each of said sequential 2-dimensional ultrasound images being assigned a serial number; b) selecting N numbers of 2-dimensional ultra-

sound images having consecutive serial numbers; c) superposing the N number of 2-dimensional ultrasound images to form a 3-dimensional ultrasound image; d) forming a flow direction marker indicating a first 2-dimensional ultrasound image from the N numbers of 2-dimensional ultrasound images; e) displaying the 3-dimensional ultrasound image together with the flow direction marker on a screen; f) removing the first 2-dimensional ultrasound image from the N numbers of 2-dimensional ultrasound images; g) selecting a (N+1)<sup>th</sup> 2-dimensional ultrasound image and superposing the selected 2-dimensional ultrasound image to the superposed 2-dimensional ultrasound images; and h) repeating the steps c) to h) as many as a predetermined number.

[0043] An apparatus of displaying an ultrasound image, comprises: a probe for transmitting ultrasound signals into a target object and receiving ultrasound echo signals; a 2-dimensional ultrasound image forming unit for forming a plurality of 2-dimensional ultrasound image based on the ultrasound image signals, each of the plurality of 2-dimensional ultrasound images being assigned a serial number; a 3-dimensional ultrasound image forming unit for selecting consecutive N numbers of 2-dimensional ultrasound images and superposing the N numbers of 2-dimensional ultrasound images, thereby forming a 3-dimensional ultrasound image; a marker setting unit for setting at least one marker on the 3-dimensional ultrasound image; and a displaying unit for displaying the 3-dimensional ultrasound image and the marker.

[0044] Any reference in this specification to "one embodiment," "an embodiment," "example embodiment," etc., means that a particular feature, structure or characteristic described in connection with the embodiment is included in at least one embodiment of the invention. The appearances of such phrases in various places in the specification are not necessarily all referring to the same embodiment. Further, when a particular feature, structure or characteristic is described in connection with any embodiment, it is submitted that it is within the purview of one skilled in the art to effect such feature, structure or characteristic in connection with other ones of the embodiments.

[0045] Although embodiments have been described with reference to a number of illustrative embodiments thereof, it should be understood that numerous other modifications and embodiments can be devised by those skilled in the art that will fall within the spirit and scope of the principles of this disclosure. More particularly, various variations and modifications are possible in the component parts and/or arrangements of the subject combination arrangement within the scope of the disclosure, the drawings and the appended claims. In addition to variations and modifications in the component parts and/or arrangements, alternative uses will also be apparent to those skilled in the art.

What is claimed is:

1. A method for displaying an ultrasound image, comprising:

- a) forming and storing a plurality of sequential 2-dimensional ultrasound images based on ultrasound echo signals reflected from a target object, each of said sequential 2-dimensional ultrasound images being assigned a serial number;

- b) selecting N numbers of 2-dimensional ultrasound images having consecutive serial numbers;
  - c) superposing the N number of 2-dimensional ultrasound images to form a 3-dimensional ultrasound image;
  - d) forming a flow direction marker indicating a first 2-dimensional ultrasound image from the N numbers of 2-dimensional ultrasound images;
  - e) displaying the 3-dimensional ultrasound image together with the flow direction marker on a screen;
  - f) removing the first 2-dimensional ultrasound image from the N numbers of 2-dimensional ultrasound images;
  - g) selecting a (N+1)<sup>th</sup> 2-dimensional ultrasound image and superposing the selected 2-dimensional ultrasound image to the superposed 2-dimensional ultrasound images; and
  - h) repeating the steps c) to h) as many as a predetermined number.
2. The method of claim 1, wherein the step c) includes individually rendering the selected 2-dimensional ultrasound images.
3. The method of claim 2, wherein the 2-dimensional ultrasound image selected at step g) is rendered and then superposed.
4. The method of claim 1, after forming the flow direction marker at step d), further comprising:
- d11) receiving a moving instruction from a user;
  - d12) moving the flow direction marker in response to the moving instruction; and
  - d13) displaying the 3-dimensional ultrasound image on a first region of the screen and a 2-dimensional ultrasound image positioned at the moved flow direction marker on a second region of the screen.
5. The method of claim 1, wherein the serial numbers are determined in an order of acquisition time of the 2-dimensional ultrasound images.
6. The method of claim 5, wherein the flow direction marker is set to indicate a first 2-dimensional ultrasound image among the superposed 2-dimensional ultrasound images.
7. The method of claim 6, wherein a time guide line parallel to a superposing direction of the 2-dimensional ultrasound images is displayed together with the 3-dimensional ultrasound image.
8. The method of claim 1, wherein the 3-dimensional ultrasound image is inversed and the inversed 3-dimensional ultrasound image is displayed.

9. The method of claim 1, after forming the 3-dimensional ultrasound image at step d), further comprising:

- d21) receiving a cutting marker setting instruction from a user;
- d22) setting at least one cutting marker on the 3-dimensional ultrasound image, thereby dividing the 3-dimensional ultrasound image into a plurality of regions;
- d23) selecting one of regions; and
- d24) displaying the selected region.

10. An apparatus of displaying an ultrasound image, comprising:

- a probe for transmitting ultrasound signals into a target object and receiving ultrasound echo signals;
- a 2-dimensional ultrasound image forming unit for forming a plurality of 2-dimensional ultrasound image based on the ultrasound image signals, each of the plurality of 2-dimensional ultrasound images being assigned a serial number;
- a 3-dimensional ultrasound image forming unit for selecting consecutive N numbers of 2-dimensional ultrasound images and superposing the N numbers of 2-dimensional ultrasound images, thereby forming a 3-dimensional ultrasound image;
- a marker setting unit for setting at least one marker on the 3-dimensional ultrasound image; and
- a displaying unit for displaying the 3-dimensional ultrasound image and the marker.

11. The apparatus of claim 10, wherein the 3-dimensional ultrasound image forming unit removes a first 2-dimensional ultrasound image from the N numbers of 2-dimensional ultrasound images, selects a (N+1)<sup>th</sup> 2-dimensional ultrasound image, and forms the 3-dimensional ultrasound image by superposing the selected 2-dimensional ultrasound images to the superposed 2-dimensional ultrasound images.

12. The apparatus of claim 11, wherein the selected 2-dimensional ultrasound images are individually rendered.

13. The apparatus of claim 11, wherein the serial numbers are determined in an order of acquisition time of the 2-dimensional ultrasound images.

14. The apparatus of claim 13, wherein the marker includes a flow direction marker indicating a first 2-dimensional ultrasound image among the superposed 2-dimensional ultrasound images and a cutting marker indicating a cutting position on the 3-dimensional ultrasound image.

\* \* \* \* \*

专利名称(译)	用于显示超声图像的设备和方法		
公开(公告)号	<a href="#">US20070167763A1</a>	公开(公告)日	2007-07-19
申请号	US11/566851	申请日	2006-12-05
申请(专利权)人(译)	MEDISON CO. , LTD.		
当前申请(专利权)人(译)	MEDISON CO. , LTD.		
[标]发明人	HYUN DONG GYU		
发明人	HYUN, DONG GYU		
IPC分类号	A61B8/00		
CPC分类号	A61B8/08 A61B8/465 A61B8/483 G01S15/8993 A61B8/523 G01S7/52073 A61B8/486		
优先权	1020050117909 2005-12-06 KR		
外部链接	<a href="#">Espacenet</a> <a href="#">USPTO</a>		

摘要(译)

本发明的实施例可以提供用于显示基于二维超声图像形成的三维超声图像的设备和方法。用于显示超声图像的方法包括：a) 基于从目标对象反射的超声回波信号形成和存储多个连续的2维超声图像，每个所述连续的2维超声图像被分配序列号；b) 选择N个具有连续序列号的二维超声图像；c) 叠加N个二维超声图像以形成三维超声图像；d) 从N个二维超声图像中形成指示第一个二维超声图像的流向标记；e) 在屏幕上显示三维超声图像和流向标记；f) 从N个二维超声图像中去除第一个二维超声图像；g) 选择第(N+1)个2维超声图像并将所选择的2维超声图像叠加到叠加的2维超声图像上；h) 重复步骤c) 至h) 多达预定数量。

