



US 20160324502A1

(19) **United States**

(12) **Patent Application Publication**

**Lu et al.**

(10) **Pub. No.: US 2016/0324502 A1**

(43) **Pub. Date: Nov. 10, 2016**

(54) **SYSTEMS AND METHODS WITH A SWELLABLE MATERIAL DISPOSED OVER A TRANSDUCER OF AN ULTRASOUND IMAGING SYSTEM**

(52) **U.S. Cl.**  
CPC ..... *A61B 8/12* (2013.01); *A61B 8/4483* (2013.01); *A61B 8/445* (2013.01); *A61B 8/4281* (2013.01)

(71) Applicant: **Boston Scientific SciMed, Inc.**, Maple Grove, MN (US)

(57) **ABSTRACT**

(72) Inventors: **Xin Lu**, Palo Alto, CA (US); **Eric Elliott**, San Francisco, CA (US)

A catheter assembly for an ultrasound system includes an elongated catheter for insertion into the cardiovascular system of a patient. The catheter includes a sheath that defines a lumen extending along the sheath. The catheter assembly also includes an imaging core for inserting into the lumen of the catheter. The imaging core includes an elongated, rotatable driveshaft and an imaging device coupled to the distal end of the driveshaft with rotation of the driveshaft causing a corresponding rotation of the imaging device. The imaging device includes at least one transducer for transforming applied electrical signals to acoustic signals and also for transforming received echo signals to electrical signals. The imaging core further includes a swellable material disposed on at least the at least one transducer and configured and arranged to rotate with rotation of the driveshaft and to swell upon exposure to a fluid.

(21) Appl. No.: **15/145,441**

(22) Filed: **May 3, 2016**

**Related U.S. Application Data**

(60) Provisional application No. 62/157,385, filed on May 5, 2015.

**Publication Classification**

(51) **Int. Cl.**  
*A61B 8/12* (2006.01)  
*A61B 8/00* (2006.01)

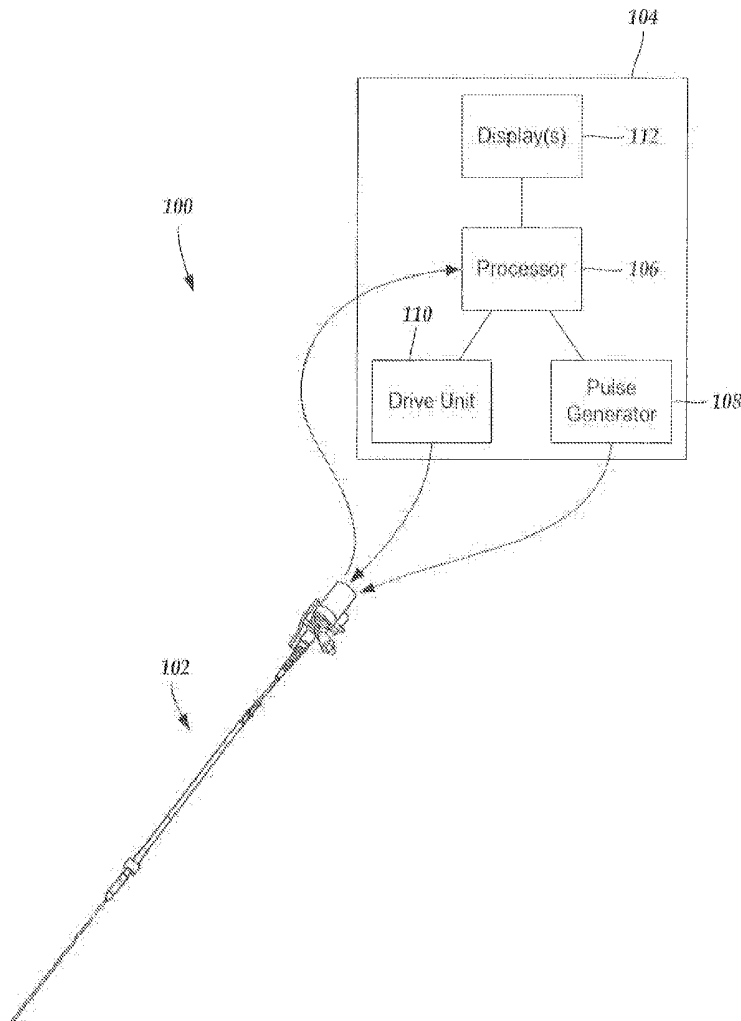

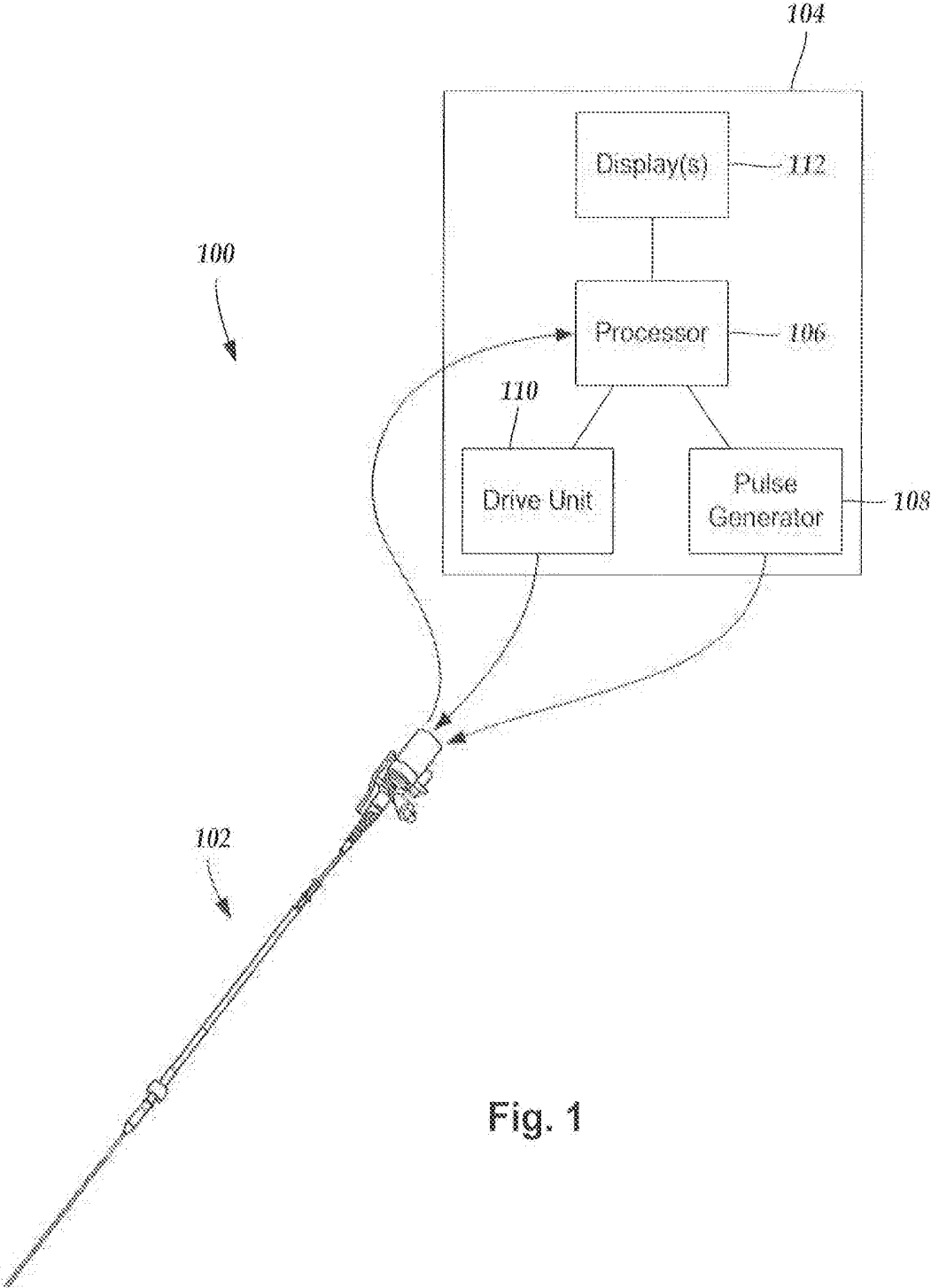

Fig. 1

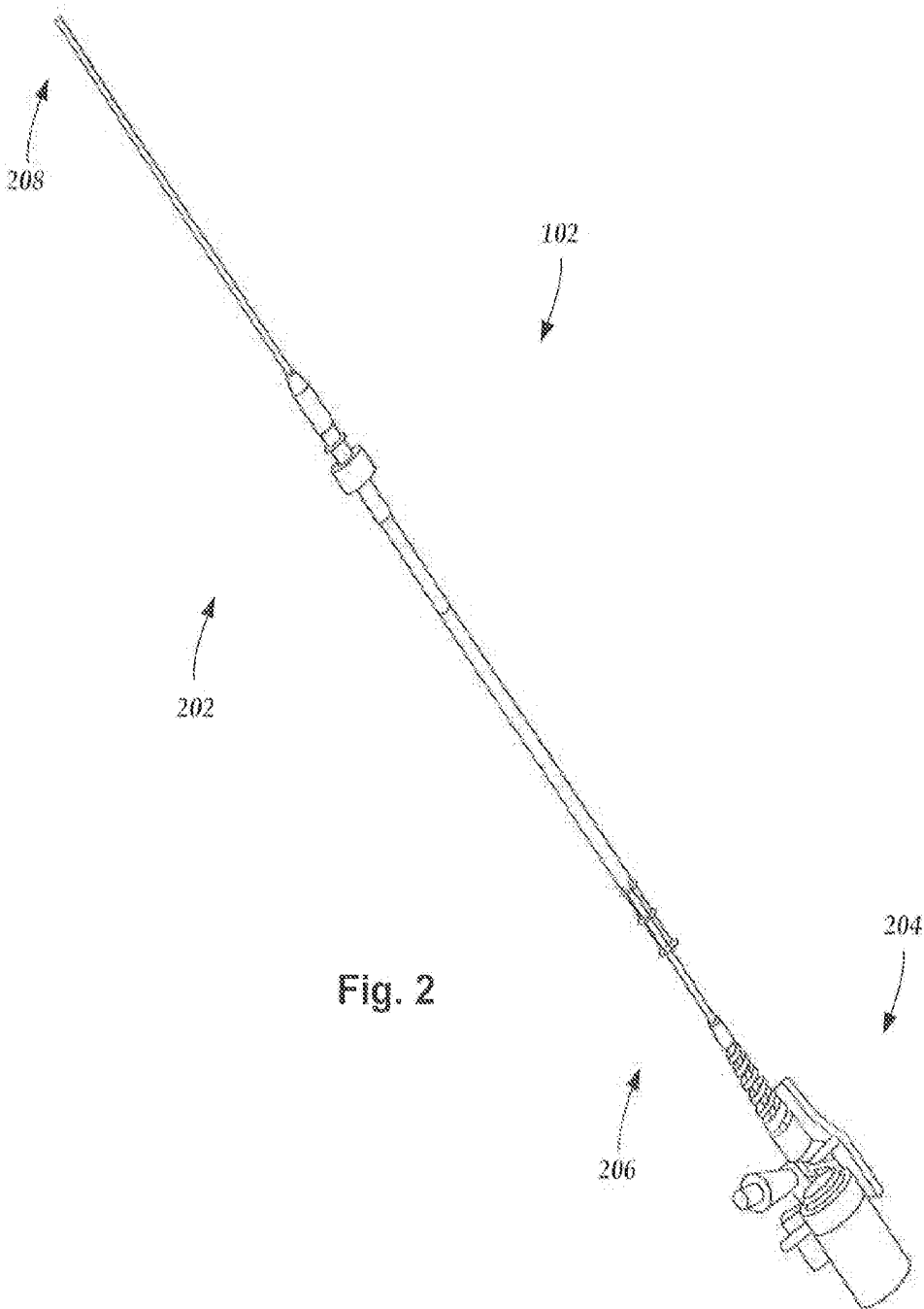

Fig. 2

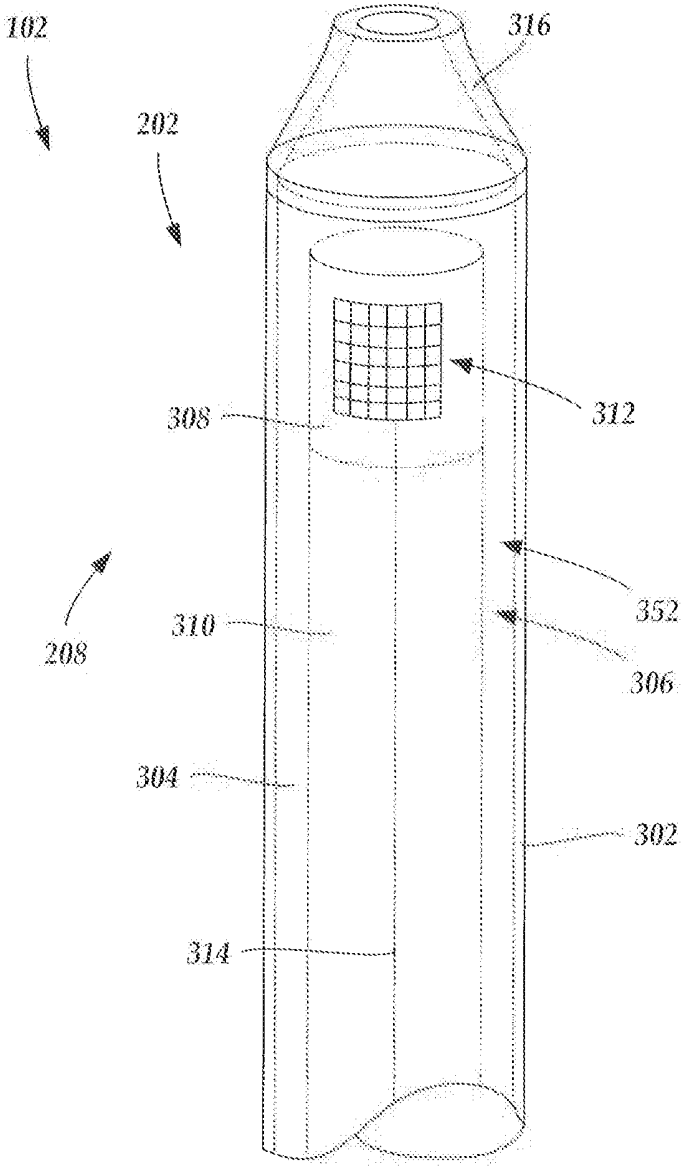

Fig. 3

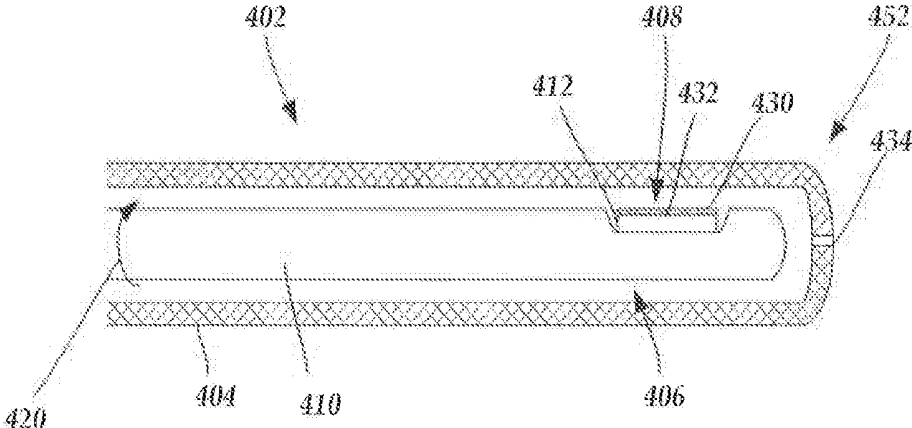

Fig. 4A

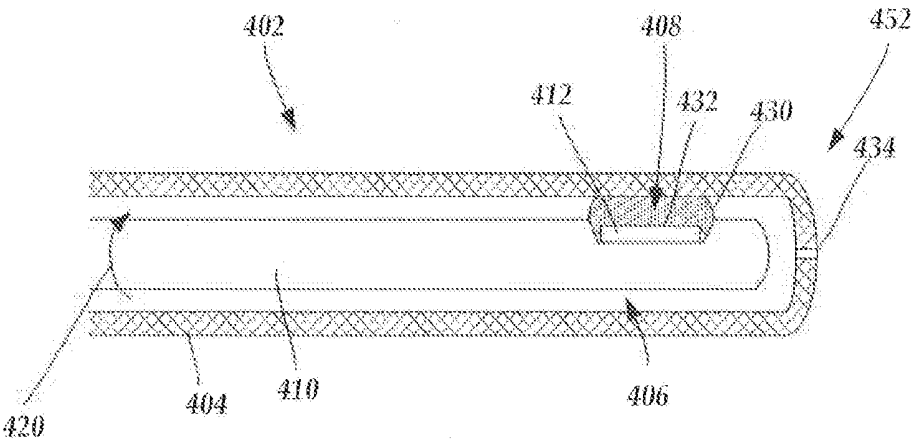

Fig. 4B

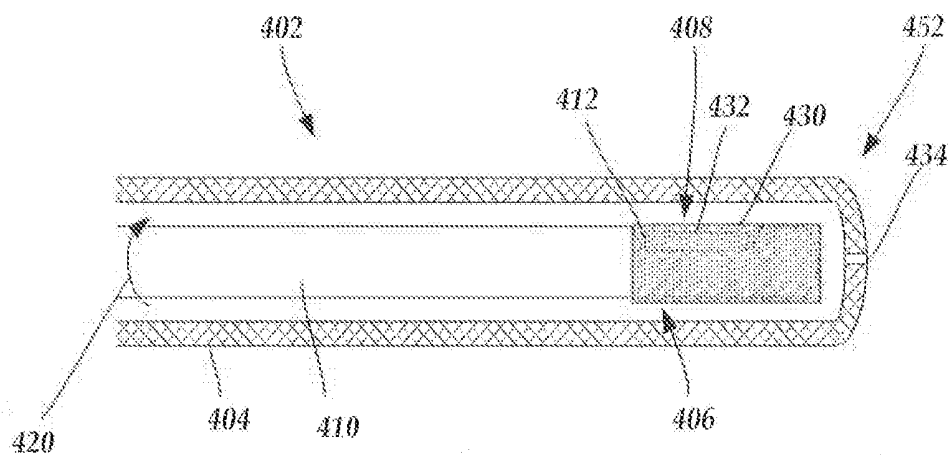

Fig. 5A

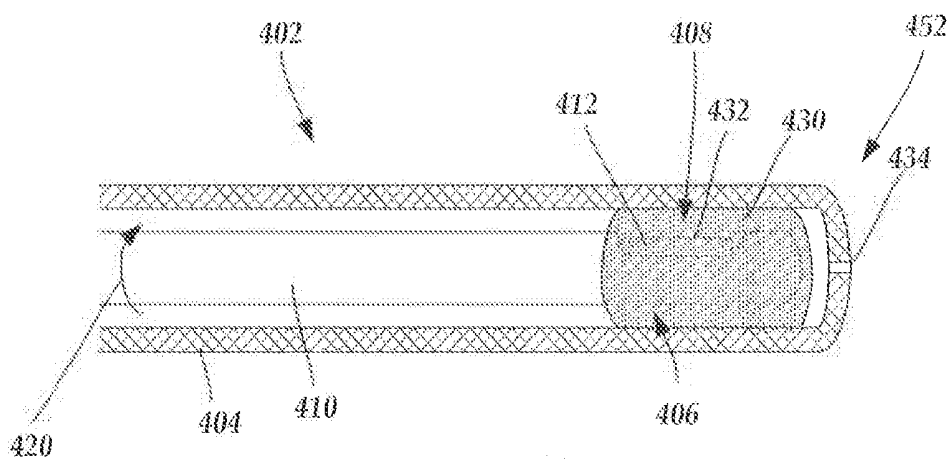

Fig. 5B

**SYSTEMS AND METHODS WITH A  
SWELLABLE MATERIAL DISPOSED OVER  
A TRANSDUCER OF AN ULTRASOUND  
IMAGING SYSTEM**

**CROSS-REFERENCE TO RELATED  
APPLICATIONS**

**[0001]** This application claims the benefit under 35 U.S.C. §119(e) of U.S. Provisional Patent Application Ser. No. 62/157,385, filed May 5, 2015, which is incorporated herein by reference.

**TECHNICAL FIELD**

**[0002]** The present invention is directed to the area of ultrasound imaging systems and methods of making and using the systems. The present invention is also directed to an ultrasound imaging system that includes a transducer disposed within a catheter and a swellable material disposed over the transducer, as well as methods of making and using the ultrasound systems, catheter, and transducer.

**BACKGROUND**

**[0003]** Ultrasound devices insertable into patients have proven diagnostic capabilities for a variety of diseases and disorders. For example, intravascular ultrasound (“IVUS”) imaging systems have been used as an imaging modality for diagnosing blocked blood vessels and providing information to aid medical practitioners in selecting and placing stents and other devices to restore or increase blood flow. IVUS imaging systems have been used to diagnose atheromatous plaque build-up at particular locations within blood vessels. IVUS imaging systems can be used to determine the existence of an intravascular obstruction or stenosis, as well as the nature and degree of the obstruction or stenosis. IVUS imaging systems can be used to visualize segments of a vascular system that may be difficult to visualize using other intravascular imaging techniques, such as angiography, due to, for example, movement (e.g., a beating heart) or obstruction by one or more structures (e.g., one or more blood vessels not desired to be imaged). IVUS imaging systems can be used to monitor or assess ongoing intravascular treatments, such as angiography and stent placement in real (or almost real) time. Moreover, IVUS imaging systems can be used to monitor one or more heart chambers.

**[0004]** IVUS imaging systems have been developed to provide a diagnostic tool for visualizing a variety of diseases or disorders. An IVUS imaging system can include a control module (with a pulse generator, an image processor, and a monitor), a catheter, and one or more transducers disposed in the catheter. The transducer-containing catheter can be positioned in a lumen or cavity within, or in proximity to, a region to be imaged, such as a blood vessel wall or patient tissue in proximity to a blood vessel wall. The pulse generator in the control module generates electrical signals that are delivered to the one or more transducers and transformed to acoustic signals that are transmitted through patient tissue. Reflected signals of the transmitted acoustic signals are absorbed by the one or more transducers and transformed to electric signals. The transformed electric signals are delivered to the image processor and converted to an image displayable on the monitor.

**[0005]** Intracardiac echocardiography (“ICE”) is another ultrasound imaging technique with proven capabilities for

use in diagnosing intravascular diseases and disorders. ICE uses acoustic signals to image patient tissue. Acoustic signals emitted from an ICE imager disposed in a catheter are reflected from patient tissue and collected and processed by a coupled ICE control module to form an image. ICE imaging systems can be used to image tissue within a heart chamber.

**BRIEF SUMMARY**

**[0006]** One embodiment is a catheter assembly for an ultrasound system. The catheter assembly includes an elongated catheter configured and arranged for insertion into the cardiovascular system of a patient, the catheter having a distal end, a proximal end, and a longitudinal length. The catheter includes a sheath with a proximal portion and a distal portion and the sheath defines a lumen extending along the sheath from the proximal portion to the distal portion. The catheter assembly also includes an imaging core configured and arranged for inserting into the lumen of the catheter. The imaging core includes an elongated, rotatable driveshaft having a proximal end and a distal end and an imaging device coupled to the distal end of the driveshaft with rotation of the driveshaft causing a corresponding rotation of the imaging device. The imaging device includes at least one transducer configured and arranged for transforming applied electrical signals to acoustic signals and also for transforming received echo signals to electrical signals. The imaging core further includes a swellable material disposed on at least the at least one transducer and configured and arranged to rotate with rotation of the driveshaft and to swell upon exposure to a fluid. In at least some embodiments, the swellable material is swollen.

**[0007]** In at least some embodiments, the swellable material is configured and arranged to swell upon exposure to at least one of water, saline, or blood. In at least some embodiments, the swellable material is a hydrogel. In at least some embodiments, the swellable material is configured and arranged to swell and fill a space immediately between the transducer and the sheath so that acoustic signals from the transducer pass from the transducer through the swellable material and directly into the sheath. In at least some embodiments, the swellable material is configured and arranged to swell and fill at least 90% of a space immediately between the transducer and the sheath. In at least some embodiments, the swellable material is mechanically or chemically attached to the imaging core. In at least some embodiments, the swellable material, when swollen, is lubricious.

**[0008]** In at least some embodiments, the catheter assembly further includes a drive unit coupled to the driveshaft, the drive unit configured and arranged for controlling rotation of the driveshaft. In at least some embodiments, the catheter assembly further includes a control module coupled to the imaging core, the control module including a pulse generator electrically coupled to the imaging core, the pulse generator configured and arranged for providing electrical signals to the at least one transducer, and a processor electrically coupled to the imaging core, the processor configured and arranged for processing received electrical signals from the at least one transducer to form at least one image.

**[0009]** Another embodiment is an imaging device that includes at least one transducer configured and arranged for transforming applied electrical signals to acoustic signals

and also for transforming received echo signals to electrical signals, and a swellable material disposed on the at least one transducer. In at least some embodiments, the swellable material is swollen.

**[0010]** In at least some embodiments, the swellable material is configured and arranged to swell upon exposure to at least one of water, saline, or blood. In at least some embodiments, the swellable material is a hydrogel. In at least some embodiments, the swellable material is mechanically or chemically attached to the at least one transducer.

**[0011]** A further embodiment is a method of forming any of the catheter assemblies or imaging devices described above. The method includes providing the at least one transducer; and disposing the swellable material on at least the at least one transducer or the imaging core.

**[0012]** In at least some embodiments, disposing the swellable material on the at least one transducer includes coating the at least one transducer with the swellable material or a precursor of the swellable material. In at least some embodiments, the method also includes crosslinking or curing the swellable material or the precursor of the swellable material to mechanically or chemically couple the swellable material to the at least one transducer or the imaging core.

**[0013]** Yet another embodiment is a method of using any of the catheter assemblies described above. The method includes inserting the imaging core into the sheath of the catheter; exposing the swellable material to the fluid causing the swellable material to swell within the sheath; and rotating the driveshaft with the swellable material swollen within the sheath.

**[0014]** In at least some embodiments, exposing the swellable material to the fluid includes injecting water or saline into the sheath of the catheter. In at least some embodiments, exposing the swellable material to the fluid includes allowing blood to flow into the sheath of the catheter. In at least some embodiments, exposing the swellable material to the fluid includes swelling the swellable material to fill a space immediately between the transducer and the sheath so that acoustic signals from the transducer pass from the transducer through the swellable material and directly into the sheath.

#### BRIEF DESCRIPTION OF THE DRAWINGS

**[0015]** Non-limiting and non-exhaustive embodiments of the present invention are described with reference to the following drawings. In the drawings, like reference numerals refer to like parts throughout the various figures unless otherwise specified.

**[0016]** For a better understanding of the present invention, reference will be made to the following Detailed Description, which is to be read in association with the accompanying drawings, wherein:

**[0017]** FIG. 1 is a schematic view of one embodiment of an intravascular ultrasound imaging system, according to the invention;

**[0018]** FIG. 2 is a schematic side view of one embodiment of a catheter of an intravascular ultrasound imaging system, according to the invention;

**[0019]** FIG. 3 is a schematic perspective view of one embodiment of a distal end of the catheter shown in FIG. 2 with an imaging core disposed in a lumen defined in the catheter, according to the invention;

**[0020]** FIG. 4A is a schematic longitudinal cross-sectional view of one embodiment of the distal end of the catheter of FIG. 3 with a swellable material, prior to swelling, disposed over the transducer, according to the invention;

**[0021]** FIG. 4B is a schematic longitudinal cross-sectional view of the embodiment of FIG. 4A with the swellable material, after swelling, disposed over the transducer, according to the invention;

**[0022]** FIG. 5A is a schematic longitudinal cross-sectional view of a second embodiment of the distal end of the catheter of FIG. 3 with a swellable material, prior to swelling, disposed over the transducer and imaging core, according to the invention; and

**[0023]** FIG. 5B is a schematic longitudinal cross-sectional view of the embodiment of FIG. 5A with the swellable material, after swelling, disposed over the transducer and imaging core, according to the invention.

#### DETAILED DESCRIPTION

**[0024]** The present invention is directed to the area of ultrasound imaging systems and methods of making and using the systems. The present invention is also directed to an ultrasound imaging system that includes a transducer disposed within a catheter and a swellable material disposed over the transducer, as well as methods of making and using the ultrasound systems, catheter, and transducer.

**[0025]** Suitable ultrasound imaging systems utilizing catheters include, for example, intravascular ultrasound (“IVUS”) and intracardiac echocardiography (“ICE”) systems. These systems may include one or more transducers disposed on a distal end of a catheter configured and arranged for percutaneous insertion into a patient. Examples of IVUS imaging systems with catheters are found in, for example, U.S. Pat. Nos. 6,945,938; 7,246,959; and 7,306,561; as well as U.S. Patent Application Publication Nos. 2006/0100522; 2006/0106320; 2006/0173350; 2006/0253028; 2007/0016054; and 2007/0038111; all of which are incorporated herein by reference.

**[0026]** FIG. 1 illustrates schematically one embodiment of an IVUS imaging system 100. An ICE imaging system is similar. The IVUS imaging system 100 includes a catheter 102 that is coupleable to a control module 104. The control module 104 may include, for example, a processor 106, a pulse generator 108, a drive unit 110, and one or more displays 112. In at least some embodiments, the pulse generator 108 forms electric signals that may be input to one or more transducers (312 in FIG. 3) disposed in the catheter 102. In at least some embodiments, mechanical energy from the drive unit 110 may be used to drive an imaging core (306 in FIG. 3) disposed in the catheter 102.

**[0027]** In at least some embodiments, electrical signals transmitted from the one or more transducers (312 in FIG. 3) may be input to the processor 106 for processing. In at least some embodiments, the processed electrical signals from the one or more transducers (312 in FIG. 3) may be displayed as one or more images on the one or more displays 112. In at least some embodiments, the processor 106 may also be used to control the functioning of one or more of the other components of the control module 104. For example, the processor 106 may be used to control at least one of the frequency or duration of the electrical signals transmitted from the pulse generator 108, the rotation rate of the imaging core (306 in FIG. 3) by the drive unit 110, the velocity or length of the pullback of the imaging core (306 in FIG. 3)

by the drive unit 110, or one or more properties of one or more images formed on the one or more displays 112.

[0028] FIG. 2 is a schematic side view of one embodiment of the catheter 102 of the IVUS imaging system (100 in FIG. 1). The catheter 102 includes an elongated member 202 and a hub 204. The elongated member 202 includes a proximal end 206 and a distal end 208. In FIG. 2, the proximal end 206 of the elongated member 202 is coupled to the catheter hub 204 and the distal end 208 of the elongated member is configured and arranged for percutaneous insertion into a patient. In some embodiments, the elongated member 202 and the hub 204 are formed as a unitary body. In other embodiments, the elongated member 202 and the catheter hub 204 are formed separately and subsequently assembled together.

[0029] FIG. 3 is a schematic perspective view of one embodiment of the distal end 208 of the catheter 102. The catheter 102 includes a sheath 302 having a distal portion 352 and a proximal portion (not shown). The sheath 302 defines a lumen 304 extending along the sheath. An imaging core 306 is disposed in the lumen 304. The imaging core 306 includes an imaging device 308 coupled to a distal end of a driveshaft 310.

[0030] The sheath 302 may be formed from any flexible, biocompatible material suitable for insertion into a patient. Examples of suitable materials include, for example, polyethylene, polyurethane, plastic, spiral-cut stainless steel, nitinol hypotube, and the like or combinations thereof.

[0031] One or more transducers 312 may be mounted to the imaging device 308 and employed to transmit and receive acoustic signals. In a preferred embodiment (as shown in FIG. 3), an array of transducers 312 are mounted to the imaging device 308. In other embodiments, a single transducer may be employed. In at least some embodiments, multiple transducers in an irregular-array may be employed. Any number of transducers 312 can be used. For example, there can be one, two, three, four, five, six, seven, eight, nine, ten, twelve, fifteen, sixteen, twenty, twenty-five, fifty, one hundred, five hundred, one thousand, or more transducers. As will be recognized, other numbers of transducers may also be used.

[0032] The one or more transducers 312 may be formed from one or more known materials capable of transforming applied electrical signals into pressure distortions on the surface of the one or more transducers 312, and vice versa. Examples of suitable materials include piezoelectric ceramic materials, piezocomposite materials, piezoelectric plastics, barium titanates, lead zirconate titanates, lead metaniobates, polyvinylidene fluorides, and the like.

[0033] The pressure distortions on the surface of the one or more transducers 312 form acoustic signals of a frequency based on the resonant frequencies of the one or more transducers 312. The resonant frequencies of the one or more transducers 312 may be affected by the size, shape, and material used to form the one or more transducers 312. The one or more transducers 312 may be formed in any shape suitable for positioning within the catheter 102 and for propagating acoustic signals of a desired frequency in one or more selected directions. For example, transducers may be disc-shaped, block-shaped, rectangular-shaped, oval-shaped, and the like. The one or more transducers may be formed in the desired shape by any process including, for example, dicing, dice and fill, machining, microfabrication, and the like.

[0034] In at least some embodiments, the one or more transducers 312 can be used to form a radial cross-sectional image of a surrounding space. Thus, for example, when the one or more transducers 312 are disposed in the catheter 102 and inserted into a blood vessel of a patient, the one or more transducers 312 may be used to form a composite image of the walls of the blood vessel and tissue surrounding the blood vessel by stitching together a plurality of individual image frames.

[0035] The imaging core 306 is rotated about a longitudinal axis of the catheter 102 while being disposed in the distal portion 352 of the sheath 302. As the imaging core 306 rotates, the one or more transducers 312 emit acoustic signal in different radial directions. When an emitted acoustic signal with sufficient energy encounters one or more medium boundaries, such as one or more tissue boundaries, a portion of the emitted acoustic signal is reflected back to the emitting transducer as an echo signal. Each echo signal that reaches a transducer with sufficient energy to be detected is transformed to an electrical signal in the receiving transducer. The one or more transformed electrical signals are transmitted to the control module (104 in FIG. 1) where the processor 106 processes the electrical-signal characteristics to generate a displayable image frame of the imaged region based, at least in part, on a collection of information from each of the acoustic signals transmitted and the echo signals received. In at least some embodiments, the rotation of the one or more transducers 312 is driven by the drive unit 110 disposed in the control module (104 in FIG. 1), via the driveshaft 310 extending along the sheath 302 of the catheter 102.

[0036] As the one or more transducers 312 rotate about the longitudinal axis of the catheter 102 emitting acoustic signals, a plurality of image frames are formed that collectively form a composite radial cross-sectional image of a portion of the region surrounding the one or more transducers 312, such as the walls of a blood vessel of interest and the tissue surrounding the blood vessel. In at least some embodiments, one or more of the image frames can be displayed on the one or more displays 112. In at least some embodiments, the radial cross-sectional composite image can be displayed on the one or more displays 112.

[0037] In at least some embodiments, the imaging core 306 may also move longitudinally (i.e., translate) along the blood vessel within which the catheter 102 is inserted so that a plurality of composite cross-sectional images may be formed into one or more larger composite images that include an axial length of the blood vessel. In at least some embodiments, during an imaging procedure the one or more transducers 312 may be retracted (i.e., pulled back) along the longitudinal length of the catheter 102. In at least some embodiments, the catheter 102 includes at least one section that can be retracted during pullback of the one or more transducers 312. In at least some embodiments, the drive unit 110 drives the pullback of the imaging core 306 within the catheter 102. In at least some embodiments, the drive unit 110 pullback distance of the imaging core is at least 5 cm, 10 cm, 15 cm, 20 cm, 25 cm or more. In at least some embodiments, the catheter 102 pullback occurs along one or more telescoping sections.

[0038] The quality of imaging at different depths from the one or more transducers 312 may be affected by one or more factors including, for example, bandwidth, transducer focus, beam pattern, as well as the frequency of the acoustic signal.

The frequency of the acoustic signal output from the one or more transducers 312 may also affect the penetration depth of the acoustic signal output from the one or more transducers 312. In general, as the frequency of an acoustic signal is lowered, the depth of the penetration of the acoustic signal within patient tissue increases. In at least some embodiments, the IVUS imaging system 100 operates within a frequency range of 5 MHz to 60 MHz.

[0039] One or more transducer conductors 314 electrically couple the transducers 312 to the control module 104 (See FIG. 1). In at least some embodiments, the one or more transducer conductors 314 extend along the driveshaft 310.

[0040] The imaging device 308 is inserted in the lumen of the catheter 102. In at least some embodiments, the catheter 102 (and imaging device 308) may be inserted percutaneously into a patient via an accessible blood vessel, such as the femoral artery or vein, at a site remote from a target imaging location. The catheter 102 may then be advanced through patient vasculature to the target imaging location, such as a portion of a selected blood vessel (e.g., a peripheral blood vessel, a coronary blood vessel, or other blood vessel), or one or more chambers of the patient's heart.

[0041] Acoustic signals propagating from the one or more transducers propagate through a portion of the lumen surrounding the imaging device before passing through the sheath to the region exterior of the catheter such as a blood vessel or a chamber of a heart. Likewise, echo signals reflected back to the one or more transducers from medium boundaries also propagate through a portion of the lumen. Typically, air is not a desirable transmission medium and image quality may, consequently, be reduced when acoustic signals or echo signals are required by catheter design to propagate through air. In the MHz range, acoustic signals may not propagate at all through air. Accordingly, it is typically advantageous, and in some cases necessary, to purge air from the lumen surrounding the one or more transducers prior to (or one or more times during) the performance of an imaging procedure.

[0042] One technique for purging air surrounding the one or more transducers is to flush the lumen with an acoustically-favorable medium, such as water or saline, through which acoustic signals more easily propagate than through air. When using a conventional IVUS imaging system, a lumen of a catheter can be manually flushed to remove air at the beginning of an IVUS imaging procedure. Additionally, the lumen of the catheter may also be manually flushed of air one or more additional times during the course of the IVUS imaging procedure. Unfortunately, each manual flushing of air from the catheter lumen can add to the amount of time it takes to perform an IVUS imaging procedure on a patient.

[0043] To reduce the need for repeated flushing during an imaging procedure, a swellable material can be disposed on the transducer. When exposed to fluid, such as water or saline, during, for example, preparation of the catheter for the imaging procedure, the swellable material swells to fill the space between the transducer and the sheath. This can provide an acoustically favorable transmission medium between the transducer and the sheath while eliminating or reducing air bubbles. In at least some embodiments, after the initial swelling of the swellable material there is no need during an imaging procedure to flush the catheter. Alternatively, additional fluid may be added during the imaging procedure to ensure that the swellable material remains

swollen. In at least some embodiments, the swellable material is already swollen prior to beginning the imaging procedure or during preparation for the imaging procedure.

[0044] FIGS. 4A and 4B are schematic longitudinal cross-sectional views of one embodiment of a distal end 452 of a catheter 402. Figures 5A and 5B illustrate a second embodiment of a distal end 452 of a catheter 402. In both embodiments, the catheter 402 includes a sheath 404 and a lumen 406 with an optional flush port 434. In both embodiments, the imaging core 408 is shown disposed in the lumen 406 of the sheath 404 at a distal portion 452 of the sheath 404. The imaging core 408 includes a rotatable driveshaft 410 with one or more transducers 412 coupled to a distal end of the driveshaft 410. The rotatable driveshaft 410 rotates the one or more transducers as illustrated by arrow 420.

[0045] A swellable material 430 is disposed on at least the one or more transducers 412. FIGS. 4A and 5A illustrate the swellable material 430 prior to swelling and FIGS. 4B and 5B illustrates the swellable material 430 after swelling. The swellable material 430 in the embodiment of FIGS. 4A and 4B is disposed on at least the acoustically active surface 432 of the one or more transducer 412 from which acoustic signals are emitted and received. In the embodiment of FIGS. 5A and 5B, the swellable material 430 is disposed over a portion of the imaging core 408 including the one or more transducers 412 and extending around the entire circumference of the core and may even extend over the distal end of the imaging core. It will be understood that other variations of the coverage of the swellable material 430 over the imaging core intermediate between the two illustrated embodiments can also be used, as well as variations where the swellable material extends further proximally or distally from the regions in the illustrated embodiments. Preferably, the swellable material 430 is disposed over at least the acoustically active surface 432 of the one or more transducer 412 and may extend over more of the imaging core 408 and further along the lumen 406 of the sheath 404.

[0046] In at least some embodiments, the swellable material 430 rotates, even when swollen, with the one or more transducers 412 upon rotation of the driveshaft 410. In some embodiments, a swellable material 430 is selected so that the swellable material, when swollen, forms a lubricious surface that facilitates rotation of the swellable material against the inner surface of the sheath 404. In at least some embodiments, the swellable material 430, when swollen, maintains structural integrity formed in the shape of the catheter lumen 406.

[0047] The swellable material 430 can be swollen using a fluid such as, for example, water, saline, or blood. In at least some embodiments, the fluid enters the catheter 402 during a flushing or other procedure. Alternatively or additionally, a fluid, such as blood, can enter the catheter 402 through flush port 434 or other port to swell the swellable material 430. In at least some embodiments, the swellable material 430 is swollen during manufacture and remains swollen thereafter.

[0048] As the swellable material 430 swells, the material displaces air bubbles within the lumen 406 of the catheter 402. Preferably, when the swellable material 430 is swollen, the material contacts the inner wall of the sheath 404. In other embodiments, the swellable material 430 fills at least 50%, 66%, 75%, 80%, 90%, 95%, or 99% of the space between the sheath 404 and the acoustically active surface 432 of the one or more transducer 412.

**[0049]** Any suitable swellable material can be used including, but not limited to, hydrogels which are often a hydrophilic network of polymer chains. Often, the polymer chains of a hydrogel are crosslinked, cured, or otherwise arranged to form the network. For example, a hydrogel can include covalent crosslinking between polymer chains, coordinate bonding between polymer chains and inorganic particles, or the like, or any combination thereof. Examples of suitable hydrogels include, but are not limited to, polyvinyl alcohol, acrylamide nano-composite hydrogel, polyvinylpyrrolidone hydrogel, or the like. A nano-composite hydrogel is a polymeric network reinforced with nanoparticles. Preferably, the swellable material is biocompatible for at least the length of time that the catheter is expected to be in contact with patient tissue (for example, at least 1, 2, 4, 8, 12, or 24 hours). In at least some embodiments, the swellable material is acoustically transparent.

**[0050]** In at least some embodiments, the swellable material **430**, or one or more precursors of the swellable material, are coated, or otherwise disposed, onto the transducer **412** (for example, on the acoustically active surface **432**) and then cross-linked or cured to mechanically or chemically adhere the swellable material to the transducer.

**[0051]** The above specification, examples and data provide a description of the manufacture and use of the composition of the invention. Since many embodiments of the invention can be made without departing from the spirit and scope of the invention, the invention also resides in the claims hereinafter appended.

What is claimed as new and desired to be protected by Letters Patent of the United States is:

1. A catheter assembly for an ultrasound system, the catheter assembly comprising:

an elongated catheter configured and arranged for insertion into the cardiovascular system of a patient, the catheter having a distal end, a proximal end, and a longitudinal length, the catheter comprising a sheath with a proximal portion and a distal portion, the sheath defining a lumen extending along the sheath from the proximal portion to the distal portion;

an imaging core configured and arranged for inserting into the lumen of the catheter, the imaging core comprising an elongated, rotatable driveshaft having a proximal end and a distal end,

an imaging device coupled to the distal end of the driveshaft with rotation of the driveshaft causing a corresponding rotation of the imaging device, the imaging device comprising at least one transducer configured and arranged for transforming applied electrical signals to acoustic signals and also for transforming received echo signals to electrical signals, and

a swellable material disposed on at least the at least one transducer and configured and arranged to rotate with rotation of the driveshaft and to swell upon exposure to a fluid, wherein, optionally, the swellable material is swollen.

2. The catheter assembly of claim 1, wherein the swellable material is configured and arranged to swell upon exposure to at least one of water, saline, or blood.

3. The catheter assembly of claim 1, wherein the swellable material is a hydrogel.

4. The catheter assembly of claim 1, wherein the swellable material is configured and arranged to swell and fill a space

immediately between the transducer and the sheath so that acoustic signals from the transducer pass from the transducer through the swellable material and directly into the sheath.

5. The catheter assembly of claim 1, wherein the swellable material is configured and arranged to swell and fill at least 90% of a space immediately between the transducer and the sheath.

6. The catheter assembly of claim 1, wherein the swellable material is mechanically or chemically attached to the imaging core.

7. The catheter assembly of claim 1, wherein the swellable material, when swollen, is lubricious.

8. The catheter assembly of claim 1, further comprising a drive unit coupled to the driveshaft, the drive unit configured and arranged for controlling rotation of the driveshaft.

9. The catheter assembly of claim 1, further comprising a control module coupled to the imaging core, the control module comprising

a pulse generator electrically coupled to the imaging core, the pulse generator configured and arranged for providing electrical signals to the at least one transducer, and

a processor electrically coupled to the imaging core, the processor configured and arranged for processing received electrical signals from the at least one transducer to form at least one image.

10. An imaging device, comprising:

at least one transducer configured and arranged for transforming applied electrical signals to acoustic signals and also for transforming received echo signals to electrical signals, and

a swellable material disposed on at least the at least one transducer, wherein, optionally, the swellable material is swollen.

11. The imaging device of claim 10, wherein the swellable material is configured and arranged to swell upon exposure to at least one of water, saline, or blood.

12. The imaging device of claim 10, wherein the swellable material is a hydrogel.

13. The imaging device of claim 10, wherein the swellable material is mechanically or chemically attached to the at least one transducer.

14. A method of forming the catheter assembly of claim 1, the method comprising:

providing the at least one transducer; and

disposing the swellable material on the at least one transducer.

15. The method of claim 14, wherein disposing the swellable material on the at least one transducer comprises coating the at least one transducer with the swellable material or a precursor of the swellable material.

16. The method of claim 15, further comprising cross-linking or curing the swellable material or the precursor of the swellable material to mechanically or chemically couple the swellable material to the imaging core.

17. A method of using the catheter assembly of claim 1, the method comprising:

inserting the imaging core into the sheath of the catheter;

exposing the swellable material to the fluid causing the swellable material to swell within the sheath; and

rotating the driveshaft with the swellable material swollen within the sheath.

18. The method of claim 17, wherein exposing the swellable material to the fluid comprises injecting water or saline into the sheath of the catheter.

19. The method of claim 17, wherein exposing the swellable material to the fluid comprises allowing blood to flow into the sheath of the catheter.

20. The method of claim 17, wherein exposing the swellable material to the fluid comprises swelling the swellable material to fill a space immediately between the transducer and the sheath so that acoustic signals from the transducer pass from the transducer through the swellable material and directly into the sheath.

\* \* \* \* \*

专利名称(译)	具有可溶胀材料的系统和方法设置在超声成像系统的换能器上		
公开(公告)号	<a href="#">US20160324502A1</a>	公开(公告)日	2016-11-10
申请号	US15/145441	申请日	2016-05-03
[标]申请(专利权)人(译)	波士顿科学西美德公司		
申请(专利权)人(译)	BOSTON SCIENTIFIC SCIMED , INC.		
当前申请(专利权)人(译)	BOSTON SCIENTIFIC SCIMED , INC.		
[标]发明人	LU XIN ELLIOTT ERIC		
发明人	LU, XIN ELLIOTT, ERIC		
IPC分类号	A61B8/12 A61B8/00		
CPC分类号	A61B8/12 A61B8/4281 A61B8/445 A61B8/4483		
优先权	62/157385 2015-05-05 US		
其他公开文献	US10456105		
外部链接	<a href="#">Espacenet</a> <a href="#">USPTO</a>		

摘要(译)

用于超声系统的导管组件包括用于插入患者的心血管系统中的细长导管。导管包括限定沿着护套延伸的内腔的护套。导管组件还包括用于插入导管的内腔中的成像芯。成像芯包括细长的可旋转驱动轴和耦合到驱动轴的远端的成像装置，其中驱动轴的旋转引起成像装置的相应旋转。成像装置包括至少一个换能器，用于将施加的电信号转换为声信号，并且还用于将接收到的回波信号转换为电信号。成像芯还包括设置在至少所述至少一个换能器上的可膨胀材料，并且构造和布置成随着驱动轴的旋转而旋转并且在暴露于流体时膨胀。

