



(19) **United States**  
(12) **Patent Application Publication**  
**Rankin et al.**

(10) **Pub. No.: US 2013/0197363 A1**  
(43) **Pub. Date: Aug. 1, 2013**

(54) **ABLATION PROBE WITH FLUID-BASED ACOUSTIC COUPLING FOR ULTRASONIC TISSUE IMAGING**

*A61B 8/12* (2006.01)  
*A61B 8/00* (2006.01)

(71) Applicants: **Darrell L. Rankin**, Milpitas, CA (US);  
**Josef V. Koblish**, Sunnyvale, CA (US);  
**Szabolcs Deladi**, Veldhoven (NL)

(52) **U.S. Cl.**  
CPC ..... *A61B 18/1492* (2013.01); *A61B 8/12* (2013.01); *A61B 8/445* (2013.01); *A61B 8/4477* (2013.01); *A61B 8/5207* (2013.01); *A61B 8/54* (2013.01); *A61B 18/1206* (2013.01); *A61M 5/00* (2013.01)

(72) Inventors: **Darrell L. Rankin**, Milpitas, CA (US);  
**Josef V. Koblish**, Sunnyvale, CA (US);  
**Szabolcs Deladi**, Veldhoven (NL)

USPC ..... **600/439**

(21) Appl. No.: **13/735,358**

(22) Filed: **Jan. 7, 2013**

**Related U.S. Application Data**

(60) Provisional application No. 61/592,908, filed on Jan. 31, 2012.

**Publication Classification**

(51) **Int. Cl.**  
*A61B 18/14* (2006.01)  
*A61M 5/00* (2006.01)  
*A61B 8/08* (2006.01)  
*A61B 18/12* (2006.01)

(57) **ABSTRACT**

Devices and systems for ultrasonically imaging tissue and performing ablation therapy are disclosed. An ablation probe for treating and imaging body tissue includes an ablation electrode tip with a number of acoustic openings and a plurality of ultrasonic imaging sensors disposed within an interior lumen of the tip. The ultrasonic imaging sensors are supported within the interior lumen via an insert equipped with a number of recesses that receive the ultrasonic imaging sensors. An acoustically transparent shell disposed between the ultrasonic imaging sensors and the acoustic openings forms a fluid channel in the acoustic pathway of the sensors. During an ablation procedure, cooling fluid from an external fluid source is delivered through the fluid channel, providing an acoustic coupling effect between the ultrasonic imaging sensors and the surrounding body tissue.

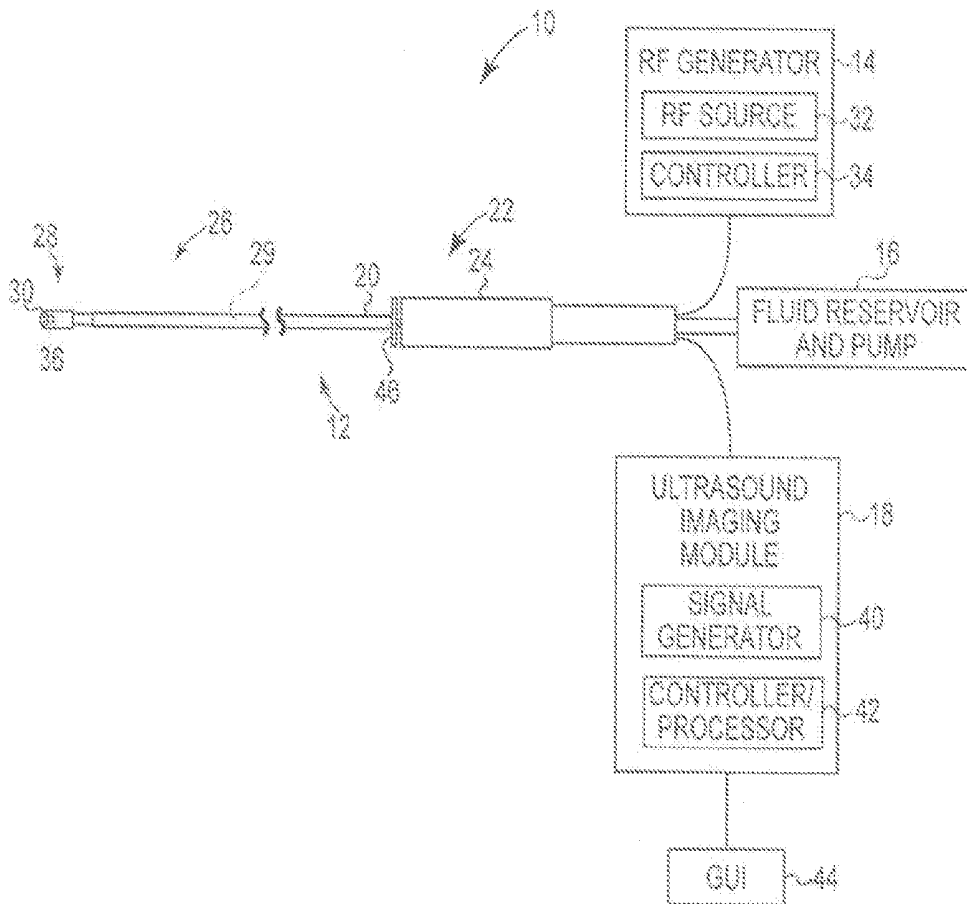

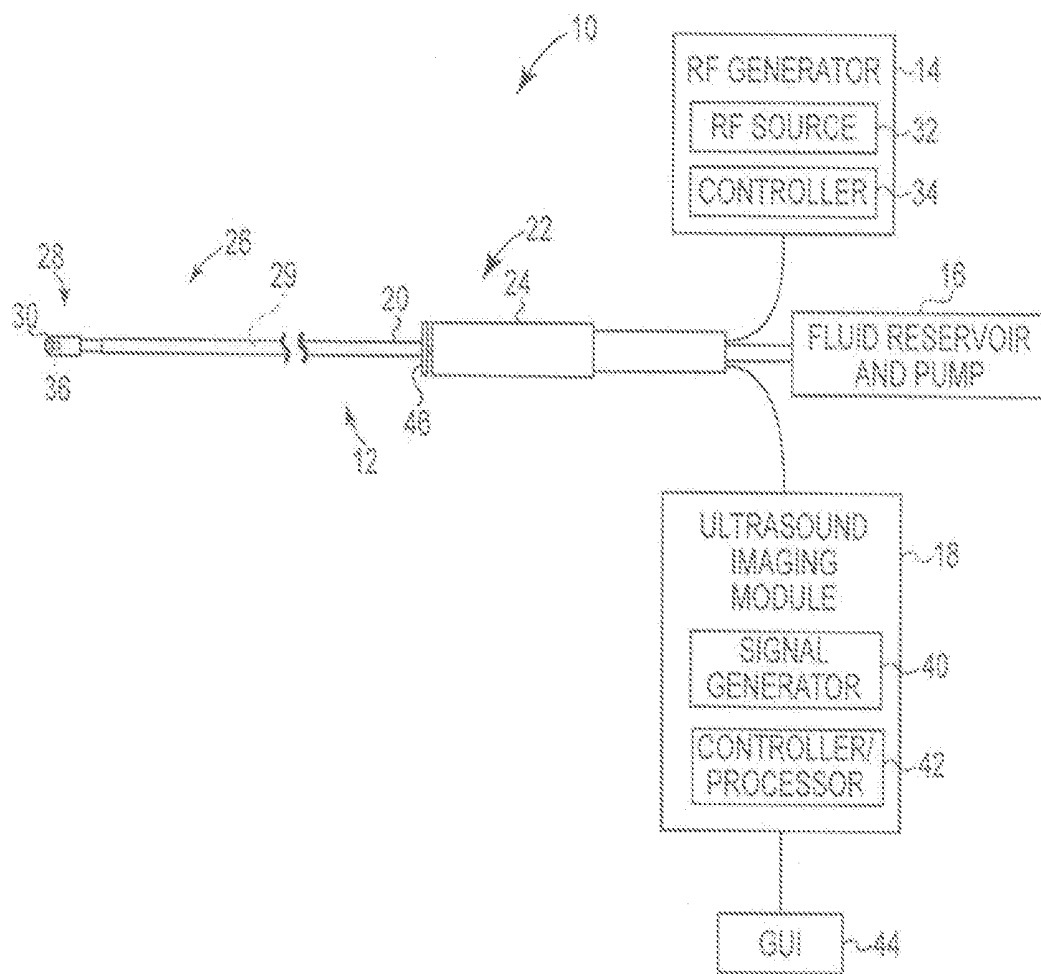

Figure 1

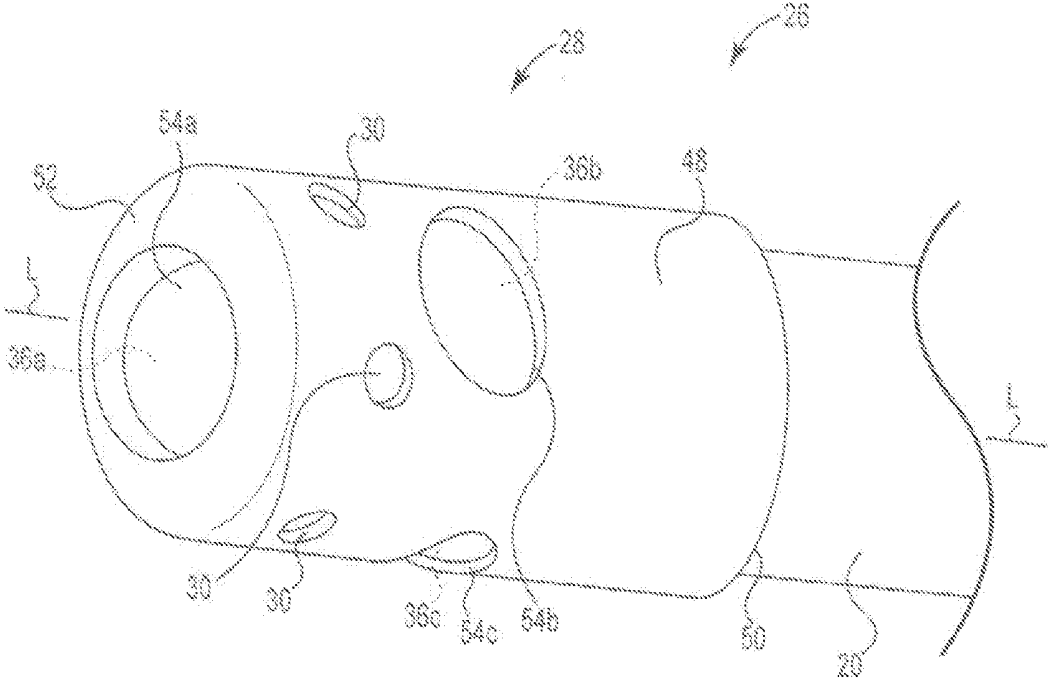

Figure 2



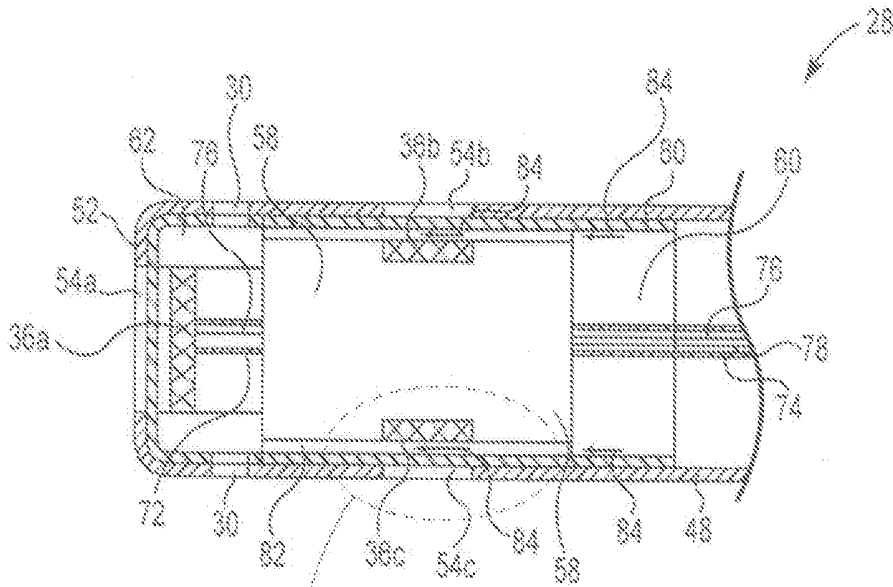

Figure 6

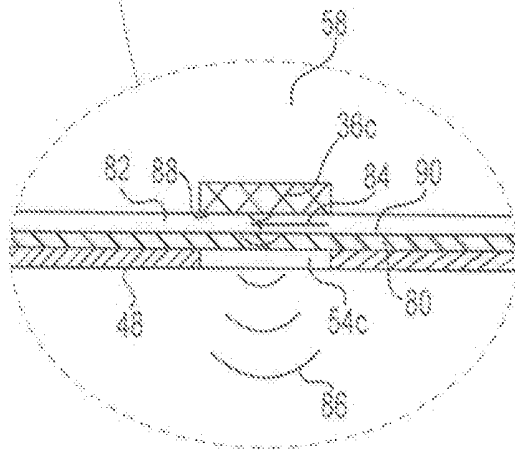

Figure 7

**ABLATION PROBE WITH FLUID-BASED  
ACOUSTIC COUPLING FOR ULTRASONIC  
TISSUE IMAGING**

CROSS-REFERENCE TO RELATED  
APPLICATION

[0001] This application claims priority to Provisional Application No. 61/592,908, filed Jan. 31, 2012, which is herein incorporated by reference in its entirety.

TECHNICAL FIELD

[0002] The present disclosure relates generally to devices and systems for imaging tissue within the body during an ablation procedure. More specifically, the present disclosure relates to an ablation probe with ultrasonic imaging capabilities.

BACKGROUND

[0003] In ablation therapy, it is often necessary to determine various characteristics of body tissue at a target ablation site within the body. In interventional cardiac electrophysiology (EP) procedures, for example, it is often necessary for the physician to determine the condition of cardiac tissue at a target ablation site in or near the heart. During some EP procedures, the physician may deliver a mapping catheter through a main vein or artery into an interior region of the heart to be treated. Using the mapping catheter, the physician may then determine the source of a cardiac rhythm disturbance or abnormality by placing a number of mapping elements carried by the catheter into contact with the adjacent cardiac tissue and then operate the catheter to generate an electrophysiology map of the interior region of the heart. Once a map of the heart is generated, the physician may then advance an ablation catheter into the heart, and position an ablation electrode carried by the catheter tip near the targeted cardiac tissue to ablate the tissue and form a lesion, thereby treating the cardiac rhythm disturbance or abnormality. In some techniques, the ablation catheter itself may include a number of mapping electrodes, allowing the same device to be used for both mapping and ablation.

[0004] Various ultrasound-based imaging catheters and probes have been developed for directly visualizing body tissue in applications such as interventional cardiology, interventional radiology, and electrophysiology. For interventional cardiac electrophysiology procedures, for example, ultrasound imaging devices have been developed that permit the visualization of anatomical structures of the heart directly and in real-time. In some electrophysiology procedures, for example, ultrasound catheters may be used to image the intra-atrial septum, to guide transseptal crossing of the atrial septum, to locate and image the pulmonary veins, and to monitor the atrial chambers of the heart for signs of a perforation and pericardial effusion.

[0005] Many ultrasound-based imaging systems comprise an imaging probe that is separate from the mapping and ablation catheters used to perform therapy on the patient. As a result, a position tracking system is sometimes used to track the location of each device within the body. In some procedures, it may be difficult for the physician to quickly and accurately determine the condition of tissue to be ablated. Moreover, the images obtained using many ultrasound-based imaging systems are often difficult to read and understand

without reference to images obtained from a separate imaging system such as a fluoroscopic imaging system.

SUMMARY

[0006] The present disclosure relates generally to devices and systems for imaging tissue within the body during an ablation procedure.

[0007] In Example 1, an ablation probe for treating and imaging body tissue comprises: an elongate probe body having a proximal section and a distal section; an ablation electrode tip coupled to the distal section of the elongate probe body, the ablation electrode tip configured for delivering ablation energy to body tissue; a plurality of acoustic openings disposed through the ablation electrode tip; a plurality of ultrasonic imaging sensors disposed within an interior lumen of the ablation electrode tip; an acoustically transparent member disposed between the ultrasonic imaging sensors and the acoustic openings; and a fluid channel interposed between the ultrasonic imaging sensors and the acoustically transparent member.

[0008] In Example 2, the probe according to Example 1, wherein each ultrasonic imaging sensor is configured to transmit ultrasonic waves through the fluid channel, the acoustically transparent member, and a corresponding one of the acoustic openings.

[0009] In Example 3, the probe according to any of Examples 1 or 2, wherein the ablation electrode tip comprises a tubular-shaped metal shell.

[0010] In Example 4, the probe according to any of Examples 1-3, wherein the acoustic openings are located circumferentially about the ablation electrode tip.

[0011] In Example 5, the probe according to any of Examples 1-4, wherein the ablation electrode tip further includes a plurality of irrigation ports.

[0012] In Example 6, the probe according to Example 5, wherein the irrigation ports are located circumferentially about the ablation electrode tip.

[0013] In Example 7, the probe according to any of Examples 5-6, wherein the irrigation ports are located distally and/or proximally of the acoustic openings.

[0014] In Example 8, the probe according to any of Examples 5-7, wherein the ultrasonic imaging sensors are located within the interior lumen of the ablation electrode tip at a location proximal to the irrigation ports.

[0015] In Example 9, the probe according to any of Examples 1-8, wherein the ultrasonic imaging sensors are each configured for transmitting laterally-directed ultrasonic waves from a side of the ablation electrode tip.

[0016] In Example 10, the probe of according to any of Examples 1-9, further comprising at least one additional ultrasonic imaging sensor disposed within the ablation electrode tip, the at least one additional ultrasonic imaging sensor configured for transmitting ultrasonic waves in a distal direction away from a distal end of the ablation electrode tip.

[0017] In Example 11, the probe according to Example 10, wherein the acoustically transparent member is further disposed between the at least one additional ultrasonic imaging sensor and a distal-facing acoustic opening disposed through the ablation electrode tip, and wherein the fluid channel is further interposed between the at least one additional ultrasonic imaging sensor and the distal-facing acoustic opening.

[0018] In Example 12, the probe according to any of Examples 1-10, wherein the acoustically transparent member comprises a tubular-shaped shell.

**[0019]** In Example 13, the probe according to any of Examples 1-12, wherein fluid within the fluid channel acoustically couples the ultrasonic imaging sensors to the body tissue.

**[0020]** In Example 14, the probe according to any of Examples 1-13, further comprising an insert configured for supporting the ultrasonic imaging sensors within the interior lumen of the ablation electrode tip.

**[0021]** In Example 15, the probe according to Example 14, wherein the insert comprises a cylindrically-shaped insert body including a plurality of recesses each configured for receiving an ultrasonic transducer therein.

**[0022]** In Example 16, the probe according to any of Examples 14-15, wherein a transmitting face of each ultrasonic imaging sensor is substantially flush with an outer surface of the insert body.

**[0023]** In Example 17, the probe according to any of Examples 14-16, wherein the interior lumen of the ablation electrode tip includes a proximal fluid chamber and a distal fluid chamber, wherein the proximal and distal fluid chambers are separated by the insert.

**[0024]** In Example 18, an ablation probe for treating and imaging body tissue comprises: an elongate probe body having a proximal section and a distal section; an ablation electrode tip coupled to the distal section of the elongate probe body, the ablation electrode tip configured for delivering ablation energy to body tissue; a plurality of acoustic openings disposed through a side of the ablation electrode tip; an insert disposed within an interior lumen of the ablation electrode tip; a plurality of lateral-facing ultrasonic imaging sensors coupled to the insert, the lateral-facing ultrasonic imaging sensors configured for transmitting ultrasonic waves from a side of the ablation electrode tip; an acoustically transparent member disposed between the lateral-facing ultrasonic imaging sensors and the acoustic openings; a fluid channel interposed between the lateral-facing ultrasonic imaging sensors and the acoustically transparent member; and at least one distal-facing ultrasonic imaging sensor disposed within the interior lumen of the ablation electrode, the distal-facing ultrasonic imaging sensor configured for transmitting ultrasonic waves in a distal direction away from a distal end of the ablation electrode tip.

**[0025]** In Example 19, an ablation and ultrasound imaging system comprises: an ablation probe including an ablation electrode tip configured for delivering ablation energy to body tissue, the ablation electrode tip comprising a plurality of acoustic openings disposed through the ablation electrode tip, a plurality of ultrasonic imaging sensors disposed within an interior lumen of the ablation electrode tip, an acoustically transparent member disposed between the ultrasonic imaging sensors and the acoustic openings, and a fluid channel interposed between the ultrasonic imaging sensors and the acoustically transparent member. The system further comprises a fluid source configured for delivering cooling fluid to the ablation electrode tip, the cooling fluid acoustically coupling the ultrasonic imaging sensors to the body tissue; an ablation therapy module configured for generating and supplying an electrical signal to the ablation electrode tip; and an ultrasound imaging module configured for processing ultrasonic imaging signals received from the ultrasonic imaging sensors.

**[0026]** In Example 20, the system according to Example 19, wherein the ultrasonic imaging module comprises a signal generator configured to generate control signals for control-

ling each ultrasonic imaging sensor; and an image processor configured for processing electrical signals received from each ultrasonic imaging sensor and generating a plurality of ultrasonic images.

**[0027]** While multiple embodiments are disclosed, still other embodiments of the present invention will become apparent to those skilled in the art from the following detailed description, which shows and describes illustrative embodiments of the invention. Accordingly, the drawings and detailed description are to be regarded as illustrative in nature and not restrictive.

#### BRIEF DESCRIPTION OF THE DRAWINGS

**[0028]** FIG. 1 is a schematic view of a combined ablation and imaging system in accordance with an illustrative embodiment;

**[0029]** FIG. 2 is a perspective view showing the distal section of the combined ablation and ultrasonic imaging probe of FIG. 1 in greater detail;

**[0030]** FIG. 3 is a schematic view showing an interior portion of the ablation electrode tip in accordance with an illustrative embodiment;

**[0031]** FIG. 4 is a perspective view of the tip insert of FIG. 3;

**[0032]** FIG. 5 is a cross-sectional view of the ablation electrode tip along line 5-5 in FIG. 3;

**[0033]** FIG. 6 is another schematic view of the ablation electrode tip showing the flow of cooling fluid across the surface of the ultrasonic imaging sensors; and

**[0034]** FIG. 7 is an enlarged view showing the transmission of ultrasonic waves from one of the ultrasonic imaging sensors through the cooling fluid, acoustically transparent shell, and acoustic opening of the ablation electrode tip.

**[0035]** While the invention is amenable to various modifications and alternative forms, specific embodiments have been shown by way of example in the drawings and are described in detail below. The intention, however, is not to limit the invention to the particular embodiments described. On the contrary, the invention is intended to cover all modifications, equivalents, and alternatives falling within the scope of the invention as defined by the appended claims.

#### DETAILED DESCRIPTION

**[0036]** FIG. 1 is a schematic view of a combined ablation and imaging system 10 in accordance with an illustrative embodiment. As shown in FIG. 1, the system 10 includes a combined ablation and ultrasonic imaging probe 12, an RF generator 14, a fluid reservoir and pump 16, and an ultrasonic imaging module 18. The probe 12 comprises an elongate probe body 20 having a proximal section 22 equipped with a handle assembly 24, and a deflectable distal section 26 including an ablation electrode tip 28. The probe body 20 includes an internal cooling fluid lumen 29 fluidly coupled to the fluid reservoir and pump 16, which supplies cooling fluid, such as saline, through the probe body 20 to a number of irrigation ports 30 in the ablation electrode tip 28. The probe body 20 may further include additional lumens or other tubular elements for supporting electrical conductors, additional fluid lumens, a thermocouple, an insertable stylet, as well as other components. In some embodiments, the probe body 20 comprises flexible plastic tubing with a braided metal mesh to increase the rotational stiffness of the body 20.

**[0037]** The RF generator **14** is configured for generating RF energy for performing ablation procedures using the ablation electrode tip **28**. The RF generator **14** includes an RF energy source **32** and a controller **34** for controlling the timing and level of the RF energy delivered by the tip **28**. During an ablation procedure, the RF generator **14** is configured to deliver ablation energy to the tip **28** in a controlled manner to ablate any sites identified or targeted for ablation. Other types of ablation sources in addition to or in lieu of the RF generator **14** can also be used for ablating target sites. Examples of other types of ablation sources can include, but are not limited to, microwave generators, acoustic generators, cryoablation generators, and laser/optical generators.

**[0038]** The ultrasonic imaging module **18** is configured for generating high resolution ultrasonic images (e.g., A, M, or B-mode images) of anatomical structures within the body based on signals received from several ultrasonic imaging sensors **36** located within the probe tip **28**. In the embodiment of FIG. 1, the ultrasonic imaging module **18** includes an ultrasonic signal generator **40** and an image processor **42**. The ultrasonic signal generator **40** is configured to provide electrical signals for controlling each of the ultrasonic imaging sensors **36**. The imaging signals received back from the ultrasonic imaging sensors **36**, in turn, are fed to the image processor **42**, which processes the signals and generates images that can be displayed on a graphical user interface (GUI) **44**. In certain embodiments, for example, the ultrasonic images displayed on the GUI **44** can be used to assist the physician with advancing the probe **12** through the body and to perform an ablation procedure. In cardiac ablation procedures, for example, the ultrasonic images generated from the ultrasound signals can be used to confirm tissue contact of the probe **12** within the heart or surrounding anatomy, to determine the orientation of the probe **12** within the body, to determine the tissue depth of the tissue at a target ablation site, and/or to visualize the progression of a lesion being formed in the tissue.

**[0039]** Various characteristics associated with the ultrasonic imaging sensors **36** as well as the circuitry within the ultrasonic imaging module **18** can be controlled to permit the sensors **36** to accurately detect tissue boundaries (e.g., blood or other bodily fluids), lesion formation and progression, as well as other characteristics of the tissue before, during, and/or after the ablation procedure. Example tissue characteristics that can be visualized using the probe **12** include, but are not limited to, the presence of fluid vaporization inside the tissue, the existence of a prior scar, the size and shape of a lesion being formed, as well as structures adjacent to heart tissue (e.g., lungs, esophagus). The depth at which the ultrasonic imaging sensors **36** can visualize anatomical structures within the body is dependent on the mechanical characteristics of the sensors **36**, the electrical characteristics of the sensor circuitry including the drive frequency of the signal generator **40**, the boundary conditions and degree of attenuation between the sensors **36** and the surrounding anatomy, as well as other factors.

**[0040]** In some embodiments, the probe **12** further includes a steering mechanism to permit the operator to deflect and steer the probe **12** within the body. In one embodiment, for example, a steering member such as a steering knob **46** rotatably coupled to the handle **24** can be used to deflect the ablation electrode tip **28** in one or multiple directions relative to a longitudinal axis of the probe body **20**. Rotational movement of the steering knob **46** in a first direction relative to the

handle **24** causes a steering wire within the probe body **20** to move proximally relative to the probe body **20**, which, in turn, bends the distal section **26** of the probe body **20** into a particular shape such as an arced shape. Rotational movement of the steering knob **46** in the opposite direction, in turn, causes the distal section **26** of the probe body **20** to return to its original shape, as shown. To assist in the deflection, and in some embodiments, the probe body **20** includes one or more regions made of a lower durometer material than the other portions of the probe body **20**.

**[0041]** Although the system **10** is described in the context of a medical system for use in intracardiac electrophysiology procedures for diagnosing and treating the heart, in other embodiments the system **10** may be used for treating, diagnosing, or otherwise visualizing other anatomical structures such as the prostate, brain, gall bladder, uterus, esophagus, and/or other regions in the body. Moreover, many of the elements in FIG. 1 are functional in nature, and are not meant to limit the structure that performs these functions in any manner. For example, several of the functional blocks can be embodied in a single device or one or more of the functional blocks can be embodied in multiple devices.

**[0042]** FIG. 2 is a perspective view showing the distal section **26** of the probe **12** of FIG. 1 in greater detail. As can be further seen in FIG. 2, the ablation electrode tip **28** includes an RF ablation electrode **48** configured for delivering ablation energy to body tissue surrounding the tip **28**. In the embodiment of FIG. 2, the RF ablation electrode **48** comprises a tubular-shaped metal shell that extends from a distal end **50** of the probe body **20** to a distal end **52** of the tip **28**. A number of exposed openings **54a**, **54b**, **54c**, **54d** disposed through the ablation electrode tip **28** form acoustic openings that permit ultrasonic waves transmitted by the ultrasonic imaging sensors **36a**, **36b**, **36c**, **36d** to pass through the tip **28** and into the surrounding tissue. The reflected ultrasonic waves received back from the tissue pass through the acoustic openings **54a**, **54b**, **54c**, **54d** and are sensed by the ultrasonic imaging sensors **36a**, **36b**, **36c**, **36d** operating in a receive mode. In some embodiments, the acoustic openings **54a**, **54b**, **54c**, **54d** comprise exposed openings or apertures formed through the wall of the ablation electrode tip **28**.

**[0043]** In addition to serving as an ablation electrode, the RF ablation electrode **48** also functions as a housing that contains the ultrasonic imaging sensors **36a**, **36b**, **36c**, **36d**, the electrical conductors coupling the RF ablation electrode **48** to the RF generator **14**, the electrical conductors coupling the ultrasonic imaging sensors **36a**, **36b**, **36c**, **36d** to the ultrasonic imaging module **18**, one or more steering wires of the steering mechanism, as well as other components. In certain embodiments, the RF ablation electrode **48** comprises an electrically conductive alloy such as platinum-iridium, which in addition to serving as an electrode for providing ablation therapy, is also used as a fluoroscopic marker to determine the location of the ablation electrode tip **28** within the body using fluoroscopy.

**[0044]** In the embodiment of FIG. 2, the probe **12** includes a distal-facing ultrasonic imaging sensor **36a** located at or near the distal end **52** of the ablation electrode tip **28**. The ultrasonic sensor **36a** is configured to transmit ultrasonic waves primarily in a forward or distal direction away from the distal end **52** of the ablation electrode tip **28**. A second set of ultrasonic imaging sensors **36b**, **36c**, **36d** disposed within the tip **28** at a location proximal to the distal-facing ultrasonic imaging sensor **36a** are configured to transmit ultrasonic

waves primarily in a lateral or side-facing direction away from the side of the ablation electrode tip 28. The reflected waves received back from the ultrasonic imaging sensors 36a, 36b, 36c, 36d produces signals that can be used by the ultrasonic imaging module 18 to generate images of the surrounding body tissue.

[0045] In some embodiments, the ultrasonic imaging sensors 36a, 36b, 36c, 36d each comprise piezoelectric transducers formed of a piezoceramic material such as lead zirconate titanate (PZT) or a piezoelectric polymer such as polyvinylidene fluoride (PVDF). In some embodiments, the ablation electrode tip 28 includes three laterally-facing ultrasonic imaging sensors 36b, 36c, 36d each oriented circumferentially at 120° intervals apart from each other about the tip 28 for use in imaging tissue located adjacent to the sides of the tip 28. In other embodiments, a greater or lesser number of laterally-facing ultrasonic imaging sensors are employed for imaging tissue adjacent to the sides of the probe tip 28.

[0046] In the embodiment of FIG. 2, the ablation electrode tip 28 has an open irrigated configuration including a number of irrigation ports 30 used to deliver cooling fluid to cool the tip 28 and the surrounding tissue. In other embodiments, the ablation electrode tip 28 has a closed irrigation configuration in which the cooling fluid is recirculated through the tip 28 without being ejected into the surrounding tissue. In some embodiments, the ablation electrode tip 28 comprises six irrigation ports 30 each disposed circumferentially at 60° intervals apart from each other about the tip 28 and at a location proximal to the distal-facing ultrasonic sensor 36a and distal to the location of the laterally-facing ultrasonic sensors 36b, 36c, 36d. In other embodiments, a greater or lesser number of fluid irrigation ports 30 are employed. In some embodiments, the fluid irrigation ports 30 are circular in shape, and have a diameter in the range of approximately 0.01 inches to 0.02 inches. The size, number, and/or positioning of the irrigation ports 30 can vary, however.

[0047] During ablation therapy, cooling fluid is used to control the temperature and reduce coagulum formation on the ablation electrode tip 28, thus preventing an impedance rise of the tissue in contact with the tip 28 and increasing the transfer of RF ablation energy delivered into the tissue. In certain embodiments, and as discussed further herein, the cooling fluid also serves as an impedance matching layer to acoustically couple the ultrasonic sensors 36a, 36b, 36c, 36d to the surrounding body tissue, thus decreasing reflections that can occur at the interface between the tissue and the sensors 36a, 36b, 36c, 36d.

[0048] FIG. 3 is a schematic view showing an interior portion of the ablation electrode tip 28 in accordance with an illustrative embodiment. As shown in FIG. 3, the ablation electrode tip 28 includes a distal tip insert 58 configured to divide the interior of the probe tip 28 into a proximal fluid chamber 60 and a distal fluid chamber 62. As can be further seen in conjunction with FIG. 4, the distal insert 58 comprises a cylindrically-shaped body 64 having an outer extent 66 with a number of recesses 68 each configured to receive a corresponding one of the lateral-facing ultrasonic imaging sensors 36b, 36c, 36d therein. In certain embodiments, for example, the distal insert 58 comprises a stainless steel body having recesses 68 sized and shaped to frictionally receive the ultrasonic imaging sensors 36b, 36c, 36d by press-fitting the sensors 36b, 36c, 36d into the recesses 68. In some embodiments, the depth of the recesses 68 are configured such that the transmitting face of the ultrasonic sensors 36b, 36c, 36d lie

substantially flush with the outer extent 66 of the insert body 64. In use, the insert body 64 separates the proximal fluid chamber 60 from the distal fluid chamber 62, creating a back pressure as fluid enters the proximal fluid chamber 60. This back pressure causes the fluid to circulate before being forced into the distal fluid chamber 62.

[0049] An internal bore 70 extending through the insert body 64 is configured to receive electrical conductors used for electrically coupling the ultrasonic sensors 36a, 36b, 36c, 36d to the ultrasonic imaging module 18. As can be further seen in FIG. 3, for example, the interior lumen 70 of the insert body 64 is connected at both ends to tubular members 72, 74 that contain electrical conductors 76, 78 for the ultrasonic sensors 36a, 36b, 36c, 36d.

[0050] FIG. 5 is a cross-sectional view of the ablation electrode tip 28 along line 5-5 of FIG. 3. As can be further seen in conjunction with FIGS. 4 and 5, a tubular-shaped shell 80 disposed radially about the tip insert body 64 defines an annular-shaped fluid channel 82 connecting the proximal fluid chamber 60 with the distal fluid chamber 62. In other embodiments, the shape of the fluid channel 82 is different from that shown. In some embodiments, the shell 80 comprises an acoustically transparent material such as clear acrylic, which has a relatively low acoustic impedance. The shell 80 also serves to fluidly seal the acoustic openings 54b, 54c, 54d from the surrounding body tissue and, in some embodiments, provides a desired acoustic coupling effect between the cooling fluid within the fluid channel 82 and the body tissue.

[0051] As can be further seen in FIG. 5, and in some embodiments, the ablation electrode tip 28 includes three laterally-facing ultrasonic imaging sensors 36b, 36c, 36d at equidistant angles of 120° about the circumference of the tip 28. Although three laterally-facing ultrasonic imaging sensors 36b, 36c, 36d are shown, a greater or lesser number of sensors may be employed in other embodiments. By way of example and not limitation, four ultrasonic imaging sensors may be disposed at equidistant angles of 90° about the circumference of the ablation electrode tip 28. In some embodiments, the laterally-facing ultrasonic imaging sensors 36b, 36c, 36d are configured to transmit ultrasonic waves in a direction perpendicular to the side of the ablation electrode tip 28. In other embodiments, the laterally-facing ultrasonic imaging sensors 36b, 36c, 36d are configured to transmit ultrasonic waves from the side of the ablation electrode tip 28 at a slight forward angle.

[0052] During imaging, the use of multiple ultrasonic imaging sensors 36b, 36c, 36d spaced about the circumference of the ablation electrode tip 28 ensures that at least one of the laterally-facing sensors 36b, 36c, 36d is in view of target tissue located to the side of the tip 28 irrespective of the tip orientation. Such configuration also permits the physician to easily visualize the target tissue without having to rotate the probe 12 once the probe 12 is in contact with the tissue.

[0053] FIG. 6 is another schematic view of the ablation electrode tip 28 showing the flow of cooling fluid 84 across the surface of the ultrasonic imaging sensors 36b, 36c, 36d. During an ablation procedure, cooling fluid 84 delivered through the probe body 20 enters into the proximal fluid chamber 60. The cooling fluid 84 then enters into the fluid channel 82 and passes across the ultrasonic imaging sensors 36b, 36c, 36d, providing an acoustic coupling effect between the sensors 36b, 36c, 36d and the shell 80. The cooling fluid

**84** then enters into the distal fluid chamber **62** and exits into the surrounding body tissue through the irrigation ports **30** shown in FIGS. 1-2.

**[0054]** FIG. 7 is an enlarged view showing the transmission of ultrasonic waves **86** from one of the ultrasonic imaging sensors **36c** through the cooling fluid **84**, shell **80**, and acoustic opening **54c** of the ablation probe tip **28**. As shown in FIG. 7, the cooling fluid **84** within the fluid channel **82** comes into contact with the transmitting/receiving surface **88** of the ultrasonic imaging sensor **30c** and the interior surface **90** of the shell **80**. The cooling fluid **84** is selected so as to have an acoustic impedance similar to that of the body tissue, which serves to facilitate transmission of the ultrasonic waves **86** into the shell **80**, through the acoustic opening **54c**, and into the tissue within minimal boundary reflection losses at each interface. A similar effect occurs for the fluid passing across the transmitting face or surface for other ultrasonic imaging sensors **36b**, **36c**.

**[0055]** Various modifications and additions can be made to the exemplary embodiments discussed without departing from the scope of the present invention. For example, while the embodiments described above refer to particular features, the scope of this invention also includes embodiments having different combinations of features and embodiments that do not include all of the described features. Accordingly, the scope of the present invention is intended to embrace all such alternatives, modifications, and variations as fall within the scope of the claims, together with all equivalents thereof.

What is claimed is:

1. An ablation probe for treating and imaging body tissue, the ablation probe comprising:

an elongate probe body having a proximal section and a distal section;

an ablation electrode tip coupled to the distal section of the elongate probe body, the ablation electrode tip configured for delivering ablation energy to body tissue;

a plurality of acoustic openings disposed through the ablation electrode tip;

a plurality of ultrasonic imaging sensors disposed within an interior lumen of the ablation electrode tip;

an acoustically transparent member disposed between the ultrasonic imaging sensors and the acoustic openings; and

a fluid channel interposed between the ultrasonic imaging sensors and the acoustically transparent member.

2. The probe of claim 1, wherein each ultrasonic imaging sensor is configured to transmit ultrasonic waves through the fluid channel, the acoustically transparent member, and a corresponding one of the acoustic openings.

3. The probe of claim 1, wherein the ablation electrode tip comprises a tubular-shaped metal shell.

4. The probe of claim 1, wherein the acoustic openings are located circumferentially about the ablation electrode tip.

5. The probe of claim 1, wherein the ablation electrode tip further includes a plurality of irrigation ports.

6. The probe of claim 5, wherein the irrigation ports are located circumferentially about the ablation electrode tip.

7. The probe of claim 5, wherein the irrigation ports are located distally and/or proximally of the acoustic openings.

8. The probe of claim 5, wherein the ultrasonic imaging sensors are located within the interior lumen of the ablation electrode tip at a location proximal to the irrigation ports.

9. The probe of claim 1, wherein the ultrasonic imaging sensors are each configured for transmitting laterally-directed ultrasonic waves from a side of the ablation electrode tip.

10. The probe of claim 9, further comprising at least one additional ultrasonic imaging sensor disposed within the ablation electrode tip, the at least one additional ultrasonic imaging sensor configured for transmitting ultrasonic waves in a distal direction away from a distal end of the ablation electrode tip.

11. The probe of claim 10, wherein the acoustically transparent member is further disposed between the at least one additional ultrasonic imaging sensor and a distal-facing acoustic opening disposed through the ablation electrode tip, and wherein the fluid channel is further interposed between the at least one additional ultrasonic imaging sensor and the distal-facing acoustic opening.

12. The probe of claim 1, wherein the acoustically transparent member comprises a tubular-shaped shell.

13. The probe of claim 1, wherein fluid within the fluid channel acoustically couples the ultrasonic imaging sensors to the body tissue.

14. The probe of claim 1, further comprising an insert configured for supporting the ultrasonic imaging sensors within the interior lumen of the ablation electrode tip.

15. The probe of claim 14, wherein the insert comprises a cylindrically-shaped insert body including a plurality of recesses each configured for receiving an ultrasonic transducer.

16. The probe of claim 14, wherein a transmitting face of each ultrasonic imaging sensor is substantially flush with an outer surface of the insert body.

17. The probe of claim 14, wherein the interior lumen of the ablation electrode tip includes a proximal fluid chamber and a distal fluid chamber, wherein the proximal and distal fluid chambers are separated by the insert.

18. An ablation probe for treating and imaging body tissue, the ablation probe comprising:

an elongate probe body having a proximal section and a distal section;

an ablation electrode tip coupled to the distal section of the elongate probe body, the ablation electrode tip configured for delivering ablation energy to body tissue;

a plurality of acoustic openings disposed through a side of the ablation electrode tip;

an insert disposed within an interior lumen of the ablation electrode tip;

a plurality of lateral-facing ultrasonic imaging sensors coupled to the insert, the lateral-facing ultrasonic imaging sensors configured for transmitting ultrasonic waves from a side of the ablation electrode tip;

an acoustically transparent member disposed between the lateral-facing ultrasonic imaging sensors and the acoustic openings;

a fluid channel interposed between the lateral-facing ultrasonic imaging sensors and the acoustically transparent member; and

at least one distal-facing ultrasonic imaging sensor disposed within the interior lumen of the ablation electrode, the distal-facing ultrasonic imaging sensor configured for transmitting ultrasonic waves in a distal direction away from a distal end of the ablation electrode tip.

19. An ablation and ultrasound imaging system, comprising:

an ablation probe including an ablation electrode tip configured for delivering ablation energy to body tissue, the ablation electrode tip comprising:

- a plurality of acoustic openings disposed through the ablation electrode tip;
  - a plurality of ultrasonic imaging sensors disposed within an interior lumen of the ablation electrode tip;
  - an acoustically transparent member disposed between the ultrasonic imaging sensors and the acoustic openings; and
  - a fluid channel interposed between the ultrasonic imaging sensors and the acoustically transparent member;
- a fluid source configured for delivering cooling fluid to the ablation electrode tip, the cooling fluid acoustically coupling the ultrasonic imaging sensors to the body tissue;
- an ablation therapy module configured for generating and supplying an electrical signal to the ablation electrode tip; and
- an ultrasound imaging module configured for processing ultrasonic imaging signals received from the ultrasonic imaging sensors.

**20.** The system of claim **19**, wherein the ultrasonic imaging module comprises:

- a signal generator configured to generate control signals for controlling each ultrasonic imaging sensor; and
- an image processor configured for processing electrical signals received from each ultrasonic imaging sensor and generating a plurality of ultrasonic images.

\* \* \* \* \*

专利名称(译)	用于超声组织成像的基于流体的声学耦合的消融探针		
公开(公告)号	<a href="#">US20130197363A1</a>	公开(公告)日	2013-08-01
申请号	US13/735358	申请日	2013-01-07
[标]申请(专利权)人(译)	RANKIN DARRELL大号 KOBISH约瑟夫V DELADI索博尔奇		
申请(专利权)人(译)	RANKIN, DARRELL L. KOBISH约瑟夫V. DELADI, 索博尔奇		
当前申请(专利权)人(译)	RANKIN, DARRELL L. KOBISH约瑟夫V. DELADI, 索博尔奇		
[标]发明人	RANKIN DARRELL L KOBISH JOSEF V DELADI SZABOLCS		
发明人	RANKIN, DARRELL L. KOBISH, JOSEF V. DELADI, SZABOLCS		
IPC分类号	A61B18/14 A61M5/00 A61B8/08 A61B18/12 A61B8/12 A61B8/00		
CPC分类号	A61B2019/5278 A61N2007/0078 A61B8/12 A61B8/445 A61B8/4477 A61B8/5207 A61B8/54 A61B18/1206 A61M5/00 A61B2018/00029 A61B8/4281 A61N7/00 A61B17/320068 A61N2007/0004 A61N2007/0043 A61B5/6852 A61B2017/00243 A61H23/0245 A61B5/6869 A61B8/4254 A61B2019/5276 A61N2007/0082 A61B8/0883 A61B5/0084 A61B2017/0237 A61B5/0044 A61B18/1492		
优先权	61/592908 2012-01-31 US		
其他公开文献	US8945015		
外部链接	<a href="#">Espacenet</a> <a href="#">USPTO</a>		

摘要(译)

公开了用于超声成像组织和执行消融治疗的装置和系统。用于治疗 and 成像身体组织的消融探针包括具有多个声学开口的消融电极尖端和设置在尖端的内腔内的多个超声成像传感器。超声成像传感器通过插入件支撑在内腔内，该插入件配备有接收超声成像传感器的多个凹槽。设置在超声成像传感器和声学开口之间的声学透明壳形成传感器的声学路径中的流体通道。在消融过程期间，来自外部流体源的冷却流体通过流体通道输送，从而在超声成像传感器和周围身体组织之间提供声耦合效应。

