



US 20090264769A1

(19) **United States**

(12) **Patent Application Publication**
Sadaka

(10) **Pub. No.: US 2009/0264769 A1**

(43) **Pub. Date: Oct. 22, 2009**

(54) **INTRAVASCULAR ULTRASOUND IMAGING SYSTEMS WITH SEALED CATHETERS FILLED WITH AN ACOUSTICALLY-FAVORABLE MEDIUM AND METHODS OF MAKING AND USING**

Publication Classification

(51) **Int. Cl.**
A61B 8/14 (2006.01)

(52) **U.S. Cl.** **600/463**

(75) **Inventor: Alain Sadaka, San Jose, CA (US)**

Correspondence Address:
Boston Scientific Corporation
Darby & Darby P.C.
P.O. Box 770, Church Street Station
New York, NY 10008-0770 (US)

(57) **ABSTRACT**

A catheter assembly for an intravascular ultrasound system includes a catheter and an imaging core. The catheter has a longitudinal length, a distal end, and a proximal end. The catheter includes a sealable lumen extending along the longitudinal length of the catheter from the proximal end to the distal end, and a movable plunger or a movable seal in fluid communication with the lumen. The movable plunger or the movable seal provides a gas-tight seal. The movable plunger or the movable seal is configured and arranged for adjusting to changes in volume of the lumen when the lumen is filled with an acoustically-favorable medium and sealed. The imaging core is configured and arranged for inserting into the sealable lumen and for coupling to a control module.

(73) **Assignee: Boston Scientific SciMed, Inc.,**
Maple Grove, MN (US)

(21) **Appl. No.: 12/425,191**

(22) **Filed: Apr. 16, 2009**

Related U.S. Application Data

(60) **Provisional application No. 61/045,904, filed on Apr. 17, 2008.**

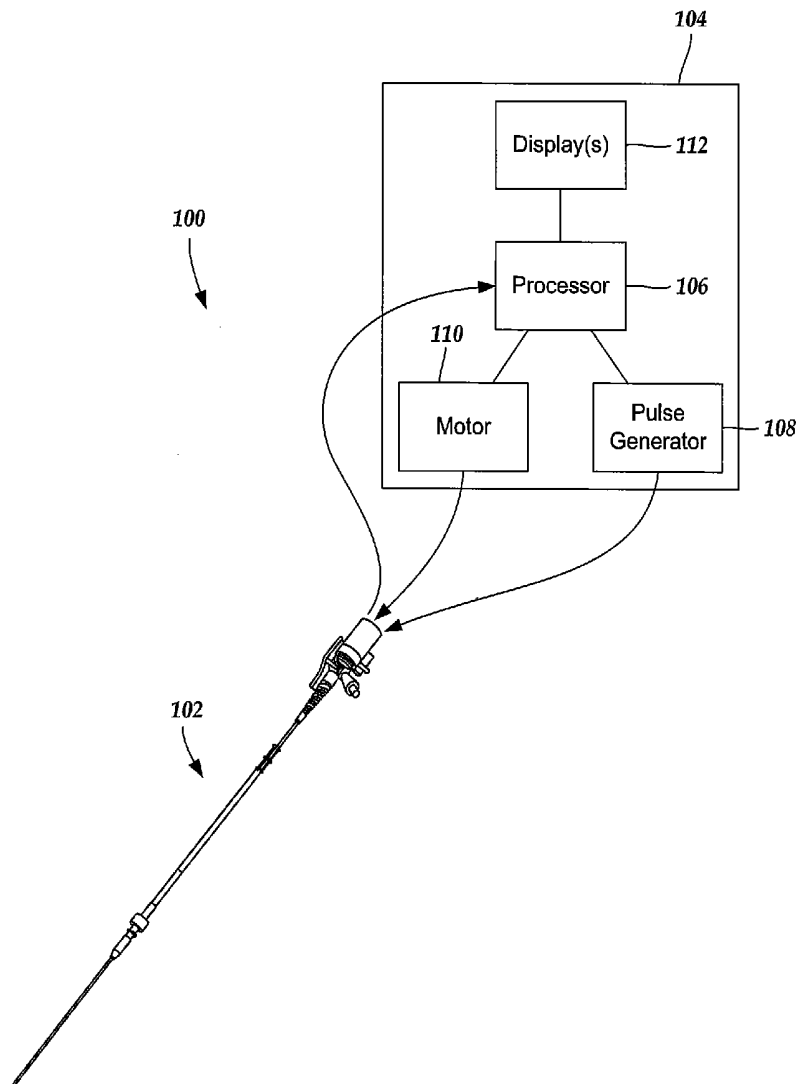

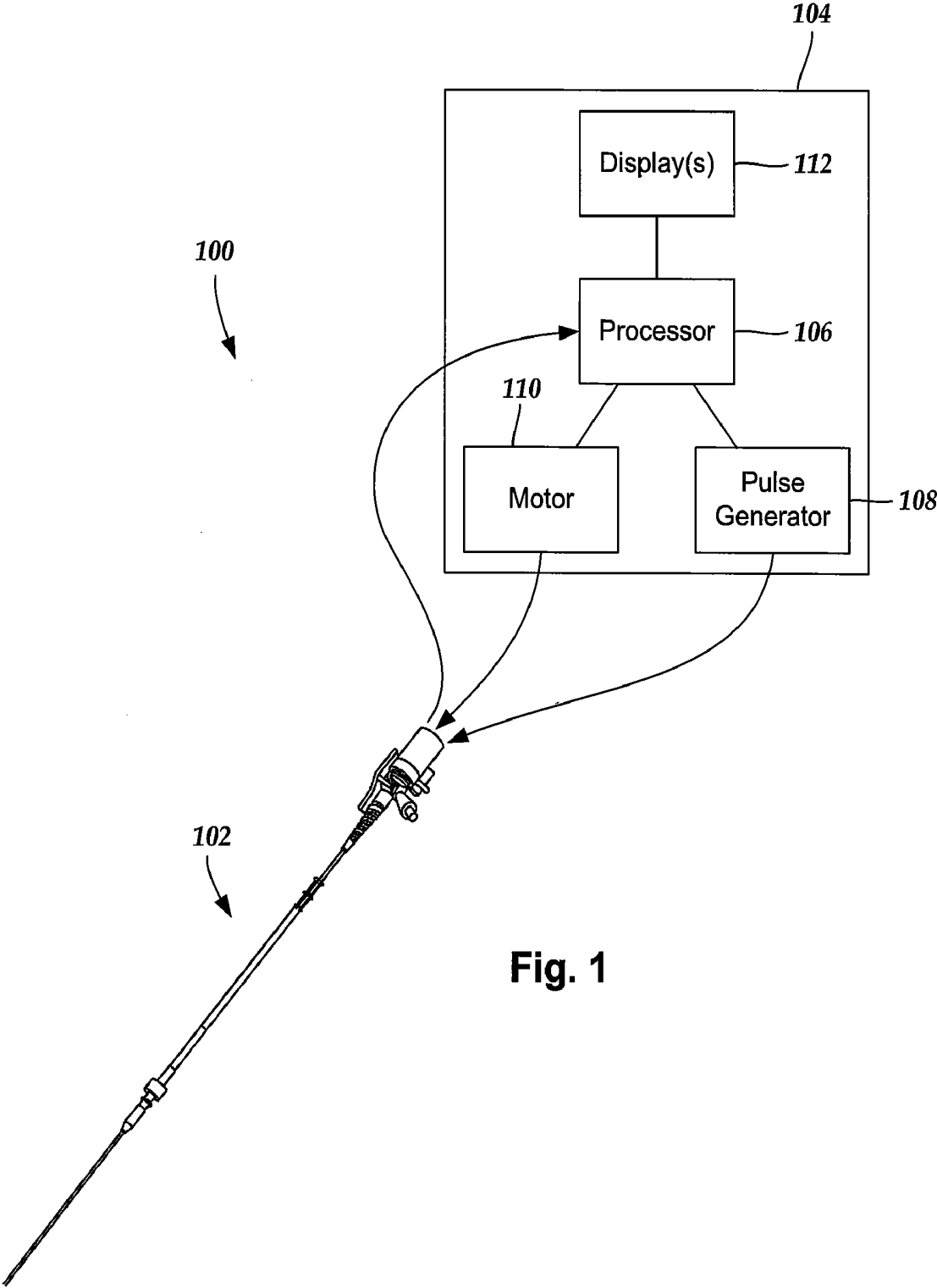

Fig. 1

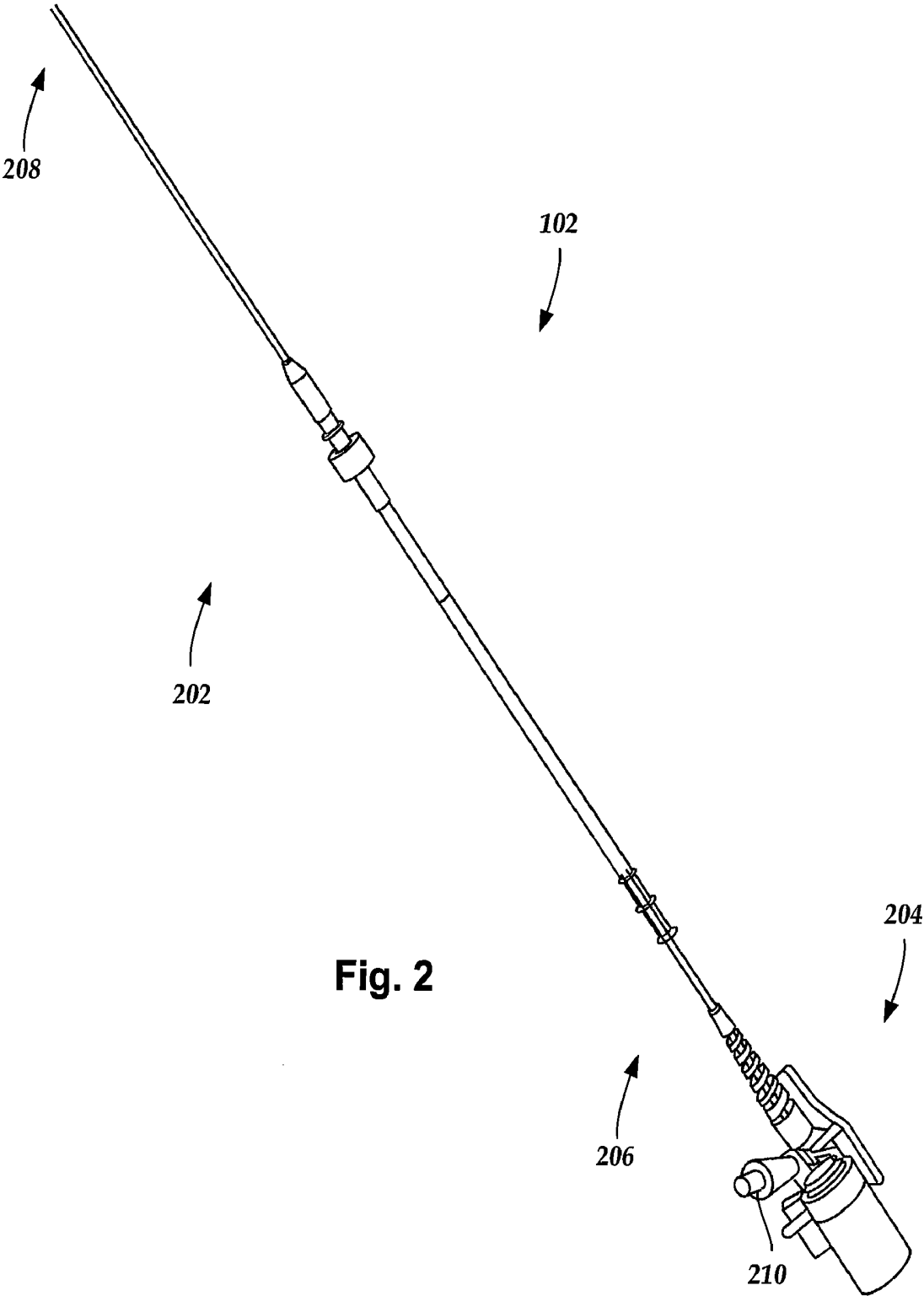

Fig. 2

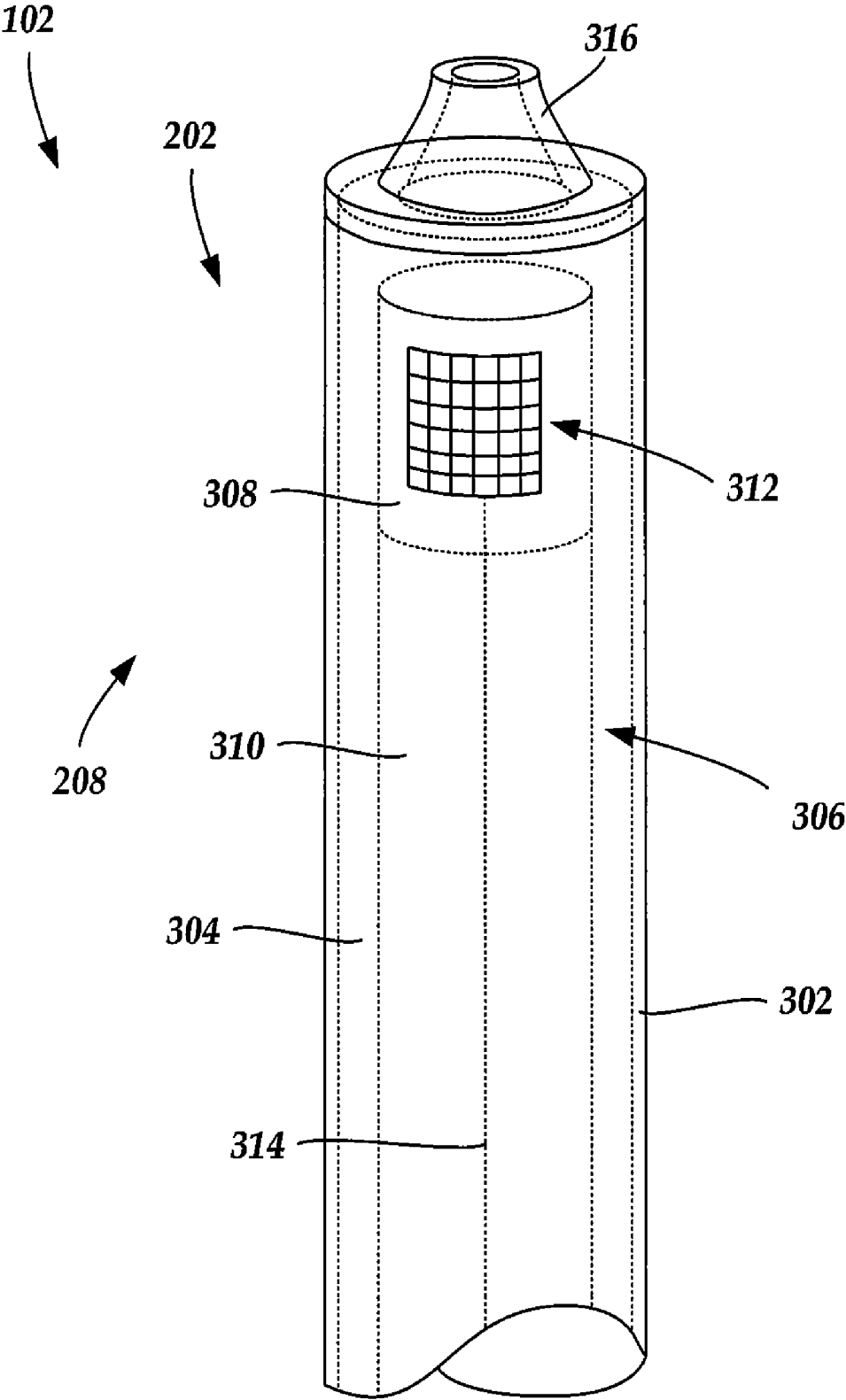

Fig. 3

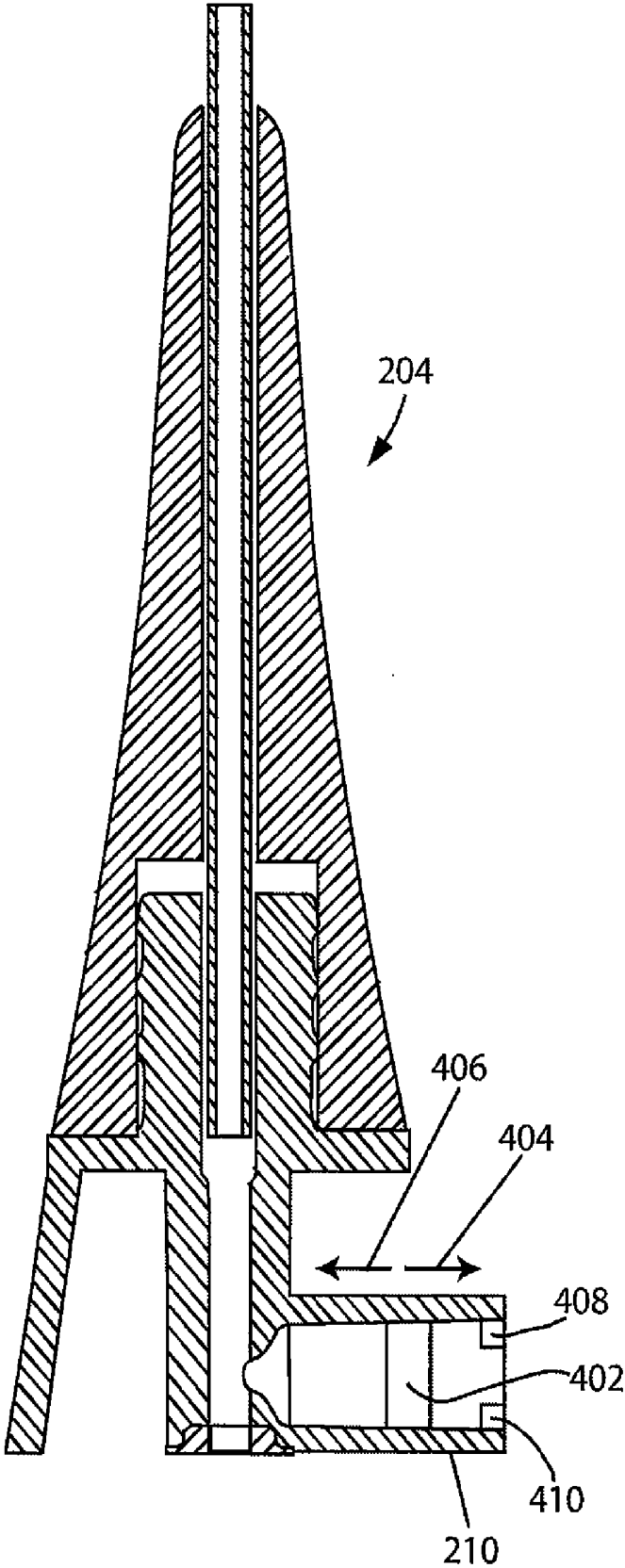

Fig. 4

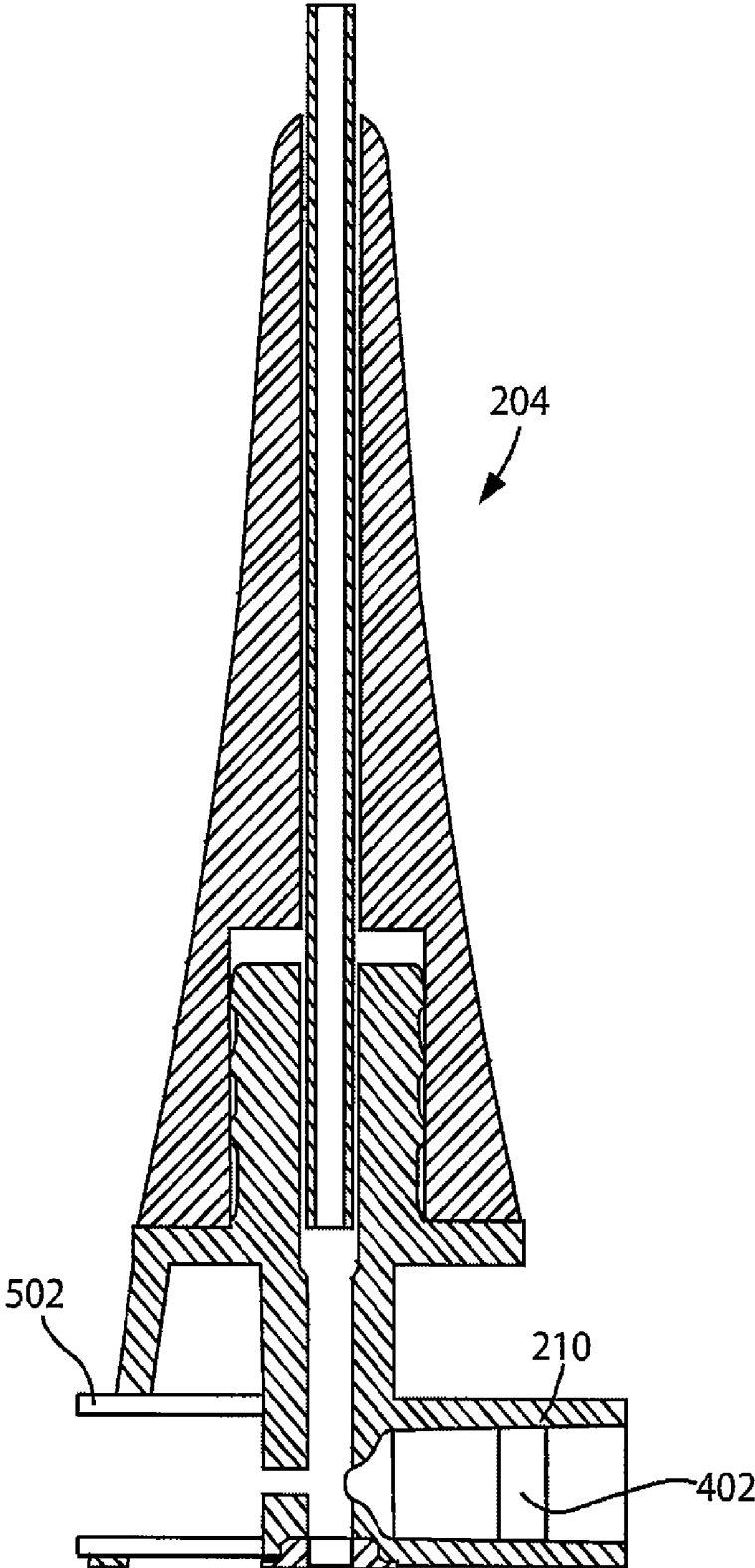

Fig. 5A

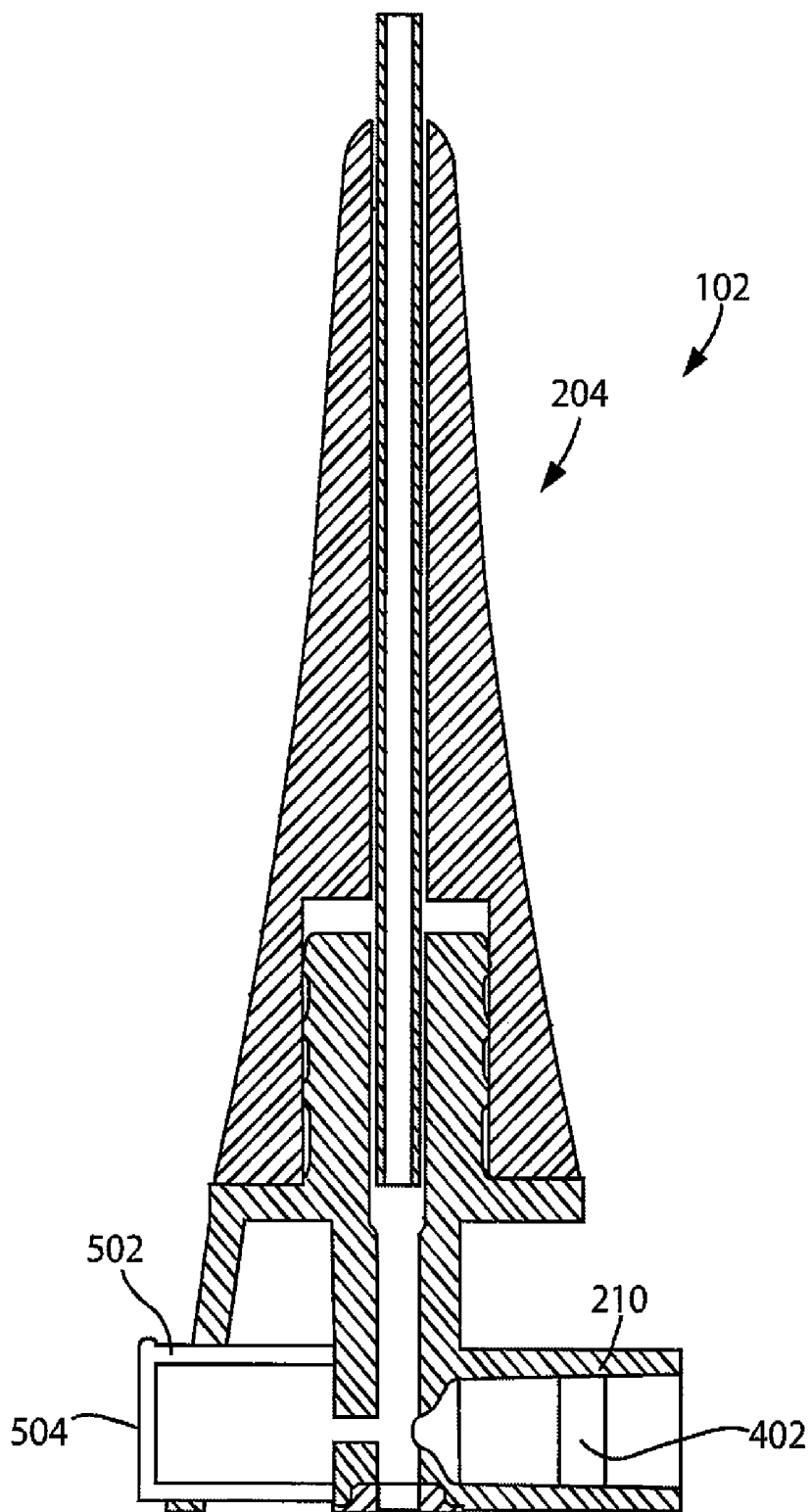

Fig. 5B

**INTRAVASCULAR ULTRASOUND IMAGING
SYSTEMS WITH SEALED CATHETERS
FILLED WITH AN
ACOUSTICALLY-FAVORABLE MEDIUM AND
METHODS OF MAKING AND USING**

CROSS REFERENCE TO RELATED
APPLICATION

[0001] This application claims the benefit of U.S. Provisional Patent Application Ser. No. 61/045,904, filed Apr. 17, 2008, the entire contents of which is incorporated by reference.

TECHNICAL FIELD

[0002] The present invention is directed to the area of intravascular ultrasound imaging systems and methods of making and using the systems. The present invention is also directed to an intravascular ultrasound imaging system with a catheter having a sealed lumen filled with an acoustically-favorable medium, as well as methods of making and using the intravascular ultrasound systems.

BACKGROUND

[0003] Intravascular ultrasound (“IVUS”) imaging systems have proven diagnostic capabilities for a variety of diseases and disorders. For example, IVUS imaging systems have been used as an imaging modality for diagnosing blocked blood vessels and providing information to aid medical practitioners in selecting and placing stents and other devices to restore or increase blood flow. IVUS imaging systems have been used to diagnose atheromatous plaque build-up at particular locations within blood vessels. IVUS imaging systems can be used to determine the existence of an intravascular obstruction or stenosis, as well as the nature and degree of the obstruction or stenosis. IVUS imaging systems can be used to visualize segments of a vascular system that may be difficult to visualize using other intravascular imaging techniques, such as angiography, due to, for example, movement (e.g., a beating heart) or obstruction by one or more structures (e.g., one or more blood vessels not desired to be imaged). IVUS imaging systems can be used to monitor or assess ongoing intravascular treatments, such as angiography and stent placement in real (or almost real) time. Moreover, IVUS imaging systems can be used to monitor one or more heart chambers.

[0004] IVUS imaging systems have been developed to provide a diagnostic tool for visualizing a variety of diseases and disorders. An IVUS imaging system can include a control module (with a pulse generator, an image processor, and a monitor), a catheter, and one or more transducers disposed in the catheter. The transducer-containing catheter can be positioned in a lumen or cavity within, or in proximity to, a region to be imaged, such as a blood vessel wall or patient tissue in proximity to a blood vessel wall. The pulse generator in the control module generates electrical pulses that are delivered to the one or more transducers and transformed to acoustic pulses that are transmitted through patient tissue. Reflected pulses of the transmitted acoustic pulses are absorbed by the one or more transducers and transformed to electric pulses.

The transformed electric pulses are delivered to the image processor and converted to an image displayable on the monitor.

BRIEF SUMMARY

[0005] In one embodiment, a catheter assembly for an intravascular ultrasound system includes a catheter and an imaging core. The catheter has a longitudinal length, a distal end, and a proximal end. The catheter includes a sealable lumen extending along the longitudinal length of the catheter from the proximal end to the distal end, and a movable plunger or a movable seal in fluid communication with the lumen. The movable plunger or the movable seal provides a gas-tight seal. The movable plunger or the movable seal is configured and arranged for adjusting to changes in volume of the lumen when the lumen is filled with an acoustically-favorable medium and sealed. The imaging core is configured and arranged for inserting into the sealable lumen and for coupling to a control module.

[0006] In another embodiment, an intravascular ultrasound imaging system includes a catheter, an imaging core, and a control module. The catheter has a longitudinal length, a distal end, and a proximal end. The catheter includes a sealable lumen extending along the longitudinal length of the catheter from the proximal end to the distal end, and a movable plunger or a movable seal in fluid communication with the lumen. The movable plunger or the movable seal provides an acoustically-favorable-medium-tight seal. The movable plunger or the movable seal is configured and arranged for adjusting to changes in volume of the lumen to maintain an acoustically-favorable-medium-filled environment within the lumen when the lumen is filled with an acoustically-favorable medium and sealed. The imaging core is disposed within the lumen. The control module is coupled to the imaging core. The control module includes a pulse generator and a processor. The pulse generator and the processor are both electrically coupled to the imaging core. The pulse generator is configured and arranged for providing electric pulses to the imaging core. The processor is configured and arranged for processing received electrical pulses from the imaging core to form at least one image.

[0007] In yet another embodiment, a method for forming a catheter of an intravascular ultrasound imaging system includes degassing a sealable lumen of the catheter, filling the sealable lumen with an acoustically-favorable medium through at least one flush port, and sealing the lumen using a movable plunger or a movable seal in fluid communication with the sealable lumen. The catheter includes at least one transducer mounted to a driveshaft extending along at least a portion of a longitudinal length of the sealable lumen. The movable plunger or the movable seal is configured and arranged to adjust to changes in volume of the lumen to maintain the substantially degassed environment in the lumen.

BRIEF DESCRIPTION OF THE DRAWINGS

[0008] Non-limiting and non-exhaustive embodiments of the present invention are described with reference to the following drawings. In the drawings, like reference numerals refer to like parts throughout the various figures unless otherwise specified.

[0009] For a better understanding of the present invention, reference will be made to the following Detailed Description, which is to be read in association with the accompanying drawings, wherein:

[0010] FIG. 1 is a schematic view of one embodiment of an intravascular ultrasound imaging system, according to the invention;

[0011] FIG. 2 is a schematic side view of one embodiment of a catheter of an intravascular ultrasound imaging system, according to the invention;

[0012] FIG. 3 is a schematic perspective view of one embodiment of a distal end of an elongated member of the catheter shown in FIG. 2 with an imaging core disposed in a lumen in the distal end of the elongated member, according to the invention;

[0013] FIG. 4 is a schematic longitudinal cross-sectional view of one embodiment of a hub of a catheter, the hub including a movable plunger disposed in a main flush port, according to the invention;

[0014] FIG. 5A is a schematic longitudinal cross-sectional view of one embodiment of a hub with a movable seal or a movable plunger disposed in a main flush port and an open auxiliary input port, according to the invention; and

[0015] FIG. 5B is a schematic longitudinal cross-sectional view of another embodiment of a hub with a movable seal or a movable plunger disposed in a main flush port and a seal disposed in an auxiliary input port, according to the invention.

DETAILED DESCRIPTION

[0016] The present invention is directed to the area of intravascular ultrasound imaging systems and methods of making and using the systems. The present invention is also directed to an intravascular ultrasound imaging system with a catheter having a sealed lumen filled with an acoustically-favorable medium, as well as methods of making and using the catheter and intravascular ultrasound system.

[0017] Suitable intravascular ultrasound (“IVUS”) imaging systems include, but are not limited to, one or more transducers disposed on a distal end of a catheter configured and arranged for percutaneous insertion into a patient. Examples of IVUS imaging systems with catheters are found in, for example, U.S. Pat. Nos. 7,306,561; and 6,945,938; as well as U.S. Patent Application Publication Nos. 20060253028; 20070016054; 20070038111; 20060173350; and 20060100522, all of which are incorporated by reference.

[0018] FIG. 1 illustrates schematically one embodiment of an IVUS imaging system 100. The IVUS imaging system 100 includes a catheter 102 that is coupleable to a control module 104. The control module 104 may include, for example, a processor 106, a pulse generator 108, a motor 110, and one or more displays 112. In at least some embodiments, the pulse generator 108 forms electric pulses that may be input to one or more transducers (312 in FIG. 3) disposed in the catheter 102. In at least some embodiments, mechanical energy from the motor 110 may be used to drive an imaging core (306 in FIG. 3) disposed in the catheter 102. In at least some embodiments, electric pulses transmitted from the one or more transducers (312 in FIG. 3) may be input to the processor 106 for processing. In at least some embodiments, the processed electric pulses from the one or more transducers (312 in FIG. 3) may be displayed as one or more images on the one or more displays 112. In at least some embodiments, the processor 106 may also be used to control the functioning of one or more of the other components of the control module 104. For

example, the processor 106 may be used to control at least one of the frequency or duration of the electrical pulses transmitted from the pulse generator 108, the rotation rate of the imaging core (306 in FIG. 3) by the motor 110, the velocity or length of the pullback of the imaging core (306 in FIG. 3) by the motor 110, or one or more properties of one or more images formed on the one or more displays 112.

[0019] FIG. 2 is a schematic side view of one embodiment of the catheter 102 of the IVUS imaging system (100 in FIG. 1). The catheter 102 includes an elongated member 202 and a hub 204. The elongated member 202 includes a proximal end 206 and a distal end 208. In FIG. 2, the proximal end 206 of the elongated member 202 is coupled to the catheter hub 204 and the distal end 208 of the elongated member is configured and arranged for percutaneous insertion into a patient. In at least some embodiments, the catheter 102 defines at least one flush port, such as flush port 210. In at least some embodiments, the flush port 210 is defined in the hub 204. In at least some embodiments, the hub 204 is configured and arranged to couple to the control module (104 in FIG. 1). In some embodiments, the elongated member 202 and the hub 204 are formed as a unitary body. In other embodiments, the elongated member 202 and the catheter hub 204 are formed separately and subsequently assembled together.

[0020] FIG. 3 is a schematic perspective view of one embodiment of the distal end 208 of the elongated member 202 of the catheter 102. The elongated member 202 includes a sheath 302 and a lumen 304. An imaging core 306 is disposed in the lumen 304. The imaging core 306 includes an imaging device 308 coupled to a distal end of a rotatable driveshaft 310.

[0021] The sheath 302 may be formed from any flexible, biocompatible material suitable for insertion into a patient. Examples of suitable materials include, for example, polyethylene, polyurethane, plastic, spiral-cut stainless steel, nitinol hypotube, and the like or combinations thereof.

[0022] One or more transducers 312 may be mounted to the imaging device 308 and employed to transmit and receive acoustic pulses. In a preferred embodiment (as shown in FIG. 3), an array of transducers 312 are mounted to the imaging device 308. In other embodiments, a single transducer may be employed. In yet other embodiments, multiple transducers in an irregular-array may be employed. Any number of transducers 312 can be used. For example, there can be two, three, four, five, six, seven, eight, nine, ten, twelve, fifteen, sixteen, twenty, twenty-five, fifty, one hundred, five hundred, one thousand, or more transducers. As will be recognized, other numbers of transducers may also be used.

[0023] The one or more transducers 312 may be formed from one or more known materials capable of transforming applied electrical pulses to pressure distortions on the surface of the one or more transducers 312, and vice versa. Examples of suitable materials include piezoelectric ceramic materials, piezocomposite materials, piezoelectric plastics, barium titanates, lead zirconate titanates, lead metaniobates, polyvinylidene fluorides, and the like.

[0024] The pressure distortions on the surface of the one or more transducers 312 form acoustic pulses of a frequency based on the resonant frequencies of the one or more transducers 312. The resonant frequencies of the one or more transducers 312 may be affected by the size, shape, and material used to form the one or more transducers 312. The one or more transducers 312 may be formed in any shape suitable for positioning within the catheter 102 and for propagating

acoustic pulses of a desired frequency in one or more selected directions. For example, transducers may be disc-shaped, block-shaped, rectangular-shaped, oval-shaped, and the like. The one or more transducers may be formed in the desired shape by any process including, for example, dicing, dice and fill, machining, microfabrication, and the like.

[0025] As an example, each of the one or more transducers **312** may include a layer of piezoelectric material sandwiched between a conductive acoustic lens and a conductive backing material formed from an acoustically absorbent material (e.g., an epoxy substrate with tungsten particles). During operation, the piezoelectric layer may be electrically excited by both the backing material and the acoustic lens to cause the emission of acoustic pulses.

[0026] In at least some embodiments, the one or more transducers **312** can be used to form a radial cross-sectional image of a surrounding space. Thus, for example, when the one or more transducers **312** are disposed in the catheter **102** and inserted into a blood vessel of a patient, the one or more transducers **312** may be used to form an image of the walls of the blood vessel and tissue surrounding the blood vessel.

[0027] In at least some embodiments, the imaging core **306** may be rotated about a longitudinal axis of the catheter **102**. As the imaging core **306** rotates, the one or more transducers **312** emit acoustic pulses in different radial directions. When an emitted acoustic pulse with sufficient energy encounters one or more medium boundaries, such as one or more tissue boundaries, a portion of the emitted acoustic pulse is reflected back to the emitting transducer as an echo pulse. Each echo pulse that reaches a transducer with sufficient energy to be detected is transformed to an electrical signal in the receiving transducer. The one or more transformed electrical signals are transmitted to the control module (**104** in FIG. 1) where the processor **106** processes the electrical-signal characteristics to form a displayable image of the imaged region based, at least in part, on a collection of information from each of the acoustic pulses transmitted and the echo pulses received. In at least some embodiments, the rotation of the imaging core **306** is driven by the motor **110** disposed in the control module (**104** in FIG. 1).

[0028] As the one or more transducers **312** rotate about the longitudinal axis of the catheter **102** emitting acoustic pulses, a plurality of images are formed that collectively form a radial cross-sectional image of a portion of the region surrounding the one or more transducers **312**, such as the walls of a blood vessel of interest and the tissue surrounding the blood vessel. In at least some embodiments, the radial cross-sectional image can be displayed on one or more displays **112**.

[0029] In at least some embodiments, the imaging core **306** may also move longitudinally along the blood vessel within which the catheter **102** is inserted so that a plurality of cross-sectional images may be formed along a longitudinal length of the blood vessel. In at least some embodiments, during an imaging procedure the one or more transducers **312** may be retracted (i.e., pulled back) along the longitudinal length of the catheter **102**. In at least some embodiments, the catheter **102** includes at least one telescoping section that can be retracted during pullback of the one or more transducers **312**. In at least some embodiments, the motor **110** drives the pullback of the imaging core **306** within the catheter **102**. In at least some embodiments, the motor **110** pullback distance of the imaging core is at least 5 cm. In at least some embodiments, the motor **110** pullback distance of the imaging core is at least 10 cm. In at least some embodiments, the motor **110**

pullback distance of the imaging core is at least 15 cm. In at least some embodiments, the motor **110** pullback distance of the imaging core is at least 20 cm. In at least some embodiments, the motor **110** pullback distance of the imaging core is at least 25 cm.

[0030] The quality of an image produced at different depths from the one or more transducers **312** may be affected by one or more factors including, for example, bandwidth, transducer focus, beam pattern, as well as the frequency of the acoustic pulse. The frequency of the acoustic pulse output from the one or more transducers **312** may also affect the penetration depth of the acoustic pulse output from the one or more transducers **312**. In general, as the frequency of an acoustic pulse is lowered, the depth of the penetration of the acoustic pulse within patient tissue increases. In at least some embodiments, the IVUS imaging system **100** operates within a frequency range of 5 MHz to 60 MHz.

[0031] In at least some embodiments, one or more conductors **314** electrically couple the transducers **312** to the control module **104** (See FIG. 1). In at least some embodiments, the one or more conductors **314** extend along a longitudinal length of the rotatable driveshaft **310**.

[0032] In at least some embodiments, the catheter **102** with one or more transducers **312** mounted to the distal end **208** of the imaging core **308** may be inserted percutaneously into a patient via an accessible blood vessel, such as the femoral artery, at a site remote from the selected portion of the selected region, such as a blood vessel, to be imaged. The catheter **102** may then be advanced through the blood vessels of the patient to the selected imaging site, such as a portion of a selected blood vessel.

[0033] Acoustic pulses propagating from the one or more transducers **312** propagate through the lumen of the catheter **102** before passing through the sheath **302** to the region exterior of the catheter **102**, such as a blood vessel or a chamber of a heart. Likewise, echo pulses reflected back to the one or more transducers **312** from medium boundaries also propagate through the lumen of the catheter **102**. Typically, air is not a desirable transmission medium and image quality may, consequently, be reduced when acoustic pulses or echo pulses are required by catheter design to propagate through air. In the MHz range, acoustic pulses may not propagate at all through air. Accordingly, it is typically advantageous, and in some cases necessary, to purge air from the lumen **304** surrounding the one or more transducers **312** prior to the performance of an imaging procedure. One technique for purging air surrounding the one or more transducers **312** is to flush the lumen **304** with an acoustically-favorable medium through which acoustic pulses more easily propagate than through air. Acoustically-favorable media may include one or more solvents such as, for example, water. An acoustically-favorable medium may include one or more solutes mixed with the one or more solvents such as, for example, one or more salts. In at least some embodiments, one or more agents may also be added, for example, to decrease the potential advancement of corrosion or microbial growth. In at least some embodiments, an acoustically-favorable medium may include a gel, and the like. In at least some embodiments, the acoustically-favorable medium may be input through the main flush port **210**. In at least some embodiments, the elongated member **202** also defines an output port **316** for outputting one or more gases.

[0034] When using a conventional IVUS imaging system, a lumen of a catheter may be flushed to remove air at the

beginning of an IVUS imaging procedure. Additionally, the lumen of the catheter may also need to be flushed of air one or more additional times during the course of the IVUS imaging procedure. Unfortunately, each flushing of air from the catheter lumen can add to the amount of time it takes for a healthcare professional to perform an IVUS imaging procedure on a patient. Moreover, the use of IVUS imaging systems often results in changes in volume of the lumen. For example, the volume of the lumen may change as the lumen twists and turns around tortuous blood vessels during placement of a catheter. Additionally, during an IVUS imaging procedure the volume of a lumen may change during pullback, as the imaging core 306 moves longitudinally along a longitudinal length of the catheter 102. As discussed above, in at least some embodiments the catheter 102 may include one or more telescoping sections that retract during pullback. In at least some embodiments, the retraction of the one or more telescoping sections may change the volume of the lumen. When the volume of a lumen changes, it may be the case that an air pocket develops across a portion of the path along which an acoustic pulse or an echo pulse propagates, thereby potentially reducing the quality of the IVUS image, or even prohibiting the IVUS imaging system 100 from forming an IVUS image.

[0035] To address these issues, in at least some embodiments the catheter 102 is filled with an acoustically-favorable medium and sealed so that the acoustically-favorable medium remains in the lumen 304. By sealing the catheter 102 with an acoustically-favorable medium, it is not necessary to flush the lumen 304 of air either before or during an IVUS imaging procedure. In at least some embodiments, the catheter 102 utilizes one or more movable seals or movable plungers in fluid communication with the lumen 304. The one or more movable seals or the movable plungers adjust to changes in the internal volume of the lumen 304 to maintain the lumen 304 of the catheter 102 filled with the acoustically-favorable medium. FIG. 4 is a schematic longitudinal cross-sectional view of one embodiment of the hub 204. The hub 204 includes a movable seal or a movable plunger 402 disposed in the main flush port 210. In at least some embodiments, the movable seal or the movable plunger 402 act like a piston moving up and down as the volume of the lumen 304 changes.

[0036] In at least some embodiments, the lumen 304 is degassed, filled with an acoustically-favorable medium, and sealed with the movable seal or the movable plunger 402. In at least some embodiments, degassing involves generating a vacuum in the lumen 304 and then filling the lumen 304 with an acoustically-favorable medium without introducing gas into the lumen 304. For example, in at least some embodiments, air in the lumen 304 is flushed out of the main flush port 210, an acoustically-favorable medium is input to the main flush port 210, and the main flush port 210 is sealed with the movable seal or the movable plunger 402. In at least some embodiments, the lumen 304 is degassed, filled with the acoustically-favorable medium, and the main flush port 210 is sealed all in one integrated step. In at least some embodiments, the operability of the imaging core 306 may be tested prior to sealing the main flush port 210.

[0037] Once the lumen 304 is filled with the acoustically-favorable medium and the main flush port 210 is sealed, the movable seal or the movable plunger 402 moves along a longitudinal length of the main flush port 210 in a direction shown by directional arrow 404 when the volume of the lumen 304 decreases. Conversely, when the volume of the

lumen 304 increases, the movable seal or the movable plunger 402 moves in a direction shown by directional arrow 406. In at least some embodiments, each seal in fluid contact with the lumen 304 is provided with a vacuum seal.

[0038] In at least some embodiments, the volume of the main flush port 210 should be sufficient to allow the movable seal or the movable plunger 402 full movement for volume changes. In at least some embodiments, the movement of the movable seal or the movable plunger 402 may be restricted to a given longitudinal movement, thereby corresponding to a given volume. For example, in at least some embodiments, one or more stops may be used to limit the longitudinal movement of the movable seal or the movable plunger 402 within the main flush port 210. In FIG. 4, stops 408 and 410 are shown for limiting the movement of the movable seal or the movable plunger 402 in the direction shown by the directional arrow 404. In other embodiments, additional stops may be employed instead of, or in addition to, the stops 408 and 410 to limit the movement of the movable seal or the movable plunger 402 in the direction shown by the directional arrow 406.

[0039] In at least some embodiments, air in the lumen 304 is flushed out of the output port 316 and an acoustically-favorable medium is input to the main flush port 210. Once the air is removed from the lumen 304 and the acoustically-favorable medium is input to the main flush port 210, the output port 316 may be sealed with a fixed seal. In some embodiments, the fixed seal is made permanent, for example, by fusing the output port 316 or plugging the output port 316 with a cap and applying epoxy around the edges of the cap. In other embodiments, the fixed seal is designed to be removable. In at least some embodiments, the output port 316 is sealed with a vacuum seal. In at least some embodiments, the lumen 304 is degassed, filled with the acoustically-favorable medium, and the main flush port 210 and the output port 316 are sealed all in one integrated step. In at least some embodiments, the imaging core 306 may be tested for operability prior to sealing the main flush port 210 and the output port 316.

[0040] In at least some embodiments, the catheter 102 may also define one or more auxiliary ports. For example, in at least some embodiments, the catheter 102 may define one or more auxiliary flush ports. FIG. 5A is a schematic longitudinal cross-sectional view of one embodiment of the hub 204. The hub 204 defines the main flush port 210 and an auxiliary flush port 502. In FIG. 5A, the movable seal or the movable plunger 402 is shown disposed in the main flush port 210 and the auxiliary flush port 502 is shown open.

[0041] In at least some embodiments, the movable seal or the movable plunger 402 may be disposed in the main flush port 210 and the auxiliary flush port 210 may be used to degas or flush the air out of the lumen 304, as described above. Once the lumen 304 is degassed and filled with an acoustically-favorable medium, the auxiliary flush port 502 may be sealed with a fixed seal (either permanent or removable), as described above. In at least some embodiments, the auxiliary flush port 502 is sealed with a vacuum seal.

[0042] FIG. 5B is a schematic longitudinal cross-sectional view of one embodiment of the hub 204 with the movable seal or the movable plunger 402 disposed in the main flush port 210 and a fixed seal 504 disposed in the auxiliary flush port 502. In at least some embodiments, the movable seal or the movable plunger 402 is disposed in the auxiliary flush port 502 and the fixed seal 504 is disposed in the main flush port

210. In at least some embodiments, a plurality of auxiliary flush ports are defined by the catheter **102**. In at least some embodiments, the fixed seal **504** or the movable seal or the movable plunger **402** is disposed in each of the auxiliary flush ports.

[0043] In at least some embodiments, one or more auxiliary output ports are defined in the catheter **102**. In at least some embodiments, the movable seal or the movable plunger **402** is disposed in the output port **316**. In at least some embodiments, the movable seal or the movable plunger **402** is disposed in one or more auxiliary output ports. In at least some embodiments, the movable seal or the movable plunger **402** is disposed in a reservoir in fluid communication with one or more of the main flush port **210**, the one or more of the auxiliary flush ports **502**, the output port **316**, or the one or more auxiliary output ports.

[0044] The above specification, examples and data provide a description of the manufacture and use of the composition of the invention. Since many embodiments of the invention can be made without departing from the spirit and scope of the invention, the invention also resides in the claims hereinafter appended.

What is claimed as new and desired to be protected by Letters Patent of the United States is:

1. A catheter assembly for an intravascular ultrasound system, the catheter assembly comprising:

a catheter having a longitudinal length, a distal end, and a proximal end, the catheter comprising
a sealable lumen extending along the longitudinal length of the catheter from the proximal end to the distal end, and

a movable plunger or a movable seal in fluid communication with the lumen, the movable plunger or the movable seal providing a gas-tight seal, the movable plunger or the movable seal configured and arranged for adjusting to changes in volume of the lumen when the lumen is filled with an acoustically-favorable medium and sealed; and

an imaging core configured and arranged for inserting into the sealable lumen and for coupling to a control module.

2. The catheter assembly of claim **1**, wherein the catheter defines a main flush port in fluid communication with the sealable lumen, the main flush port is configured and arranged for inputting the acoustically-favorable medium to the sealable lumen.

3. The catheter assembly of claim **2**, wherein the movable plunger or the movable seal is disposed in the main flush port.

4. The catheter assembly of claim **1**, further including at least one auxiliary flush port in fluid communication with the sealable lumen, the at least one auxiliary flush port configured and arranged for inputting the acoustically-favorable medium to the sealable lumen.

5. The catheter assembly of claim **4**, wherein the auxiliary flush port is configured and arranged to receive a fixed seal.

6. The catheter assembly of claim **4**, wherein the movable plunger or the movable seal is disposed in the auxiliary flush port.

7. The catheter assembly of claim **1**, wherein the catheter defines an output port in fluid communication with the sealable lumen, the output port configured and arranged for flushing out gas from the sealable lumen.

8. The catheter assembly of claim **7**, wherein the output port is configured and arranged to receive one of i) a fixed seal, or ii) the movable plunger or the movable seal.

9. The catheter assembly of claim **1**, wherein the catheter further defines at least one auxiliary output port in fluid communication with the sealable lumen, the at least one auxiliary output port configured and arranged for flushing out gas from the sealable lumen.

10. The catheter assembly of claim **1**, wherein the movable plunger or the movable seal is disposed in a reservoir in fluid communication with the sealable lumen.

11. The catheter assembly of claim **1**, wherein the movable plunger or the movable seal provides a vacuum seal.

12. The catheter assembly of claim **1**, wherein the catheter further comprises at least one telescoping section.

13. The catheter assembly of claim **1**, wherein the imaging core comprises

a rotatable driveshaft having a distal end; and
an imaging device mounted to the distal end of the rotatable driveshaft, the imaging device comprising at least one transducer mounted to the imaging device, the at least one transducer configured and arranged for transforming applied electrical pulses to acoustic pulses and also for transforming received echo pulses to electrical pulses.

14. An intravascular ultrasound imaging system comprising:

a catheter having a longitudinal length, a distal end, and a proximal end, the catheter comprising

a sealable lumen extending along the longitudinal length of the catheter from the proximal end to the distal end, and

a movable plunger or a movable seal in fluid communication with the lumen, the movable plunger or the movable seal providing an acoustically-favorable-medium-tight seal, the movable plunger or the movable seal configured and arranged for adjusting to changes in volume of the lumen to maintain an acoustically-favorable-medium-filled environment within the lumen when the lumen is filled with an acoustically-favorable medium and sealed;

an imaging core disposed within the lumen; and

a control module coupled to the imaging core, the control module comprising

a pulse generator electrically coupled to the imaging core, the pulse generator configured and arranged for providing electric pulses to the imaging core, and
a processor electrically coupled to the imaging core, the processor configured and arranged for processing received electrical pulses from the imaging core to form at least one image.

15. The intravascular ultrasound imaging system of claim **14**, wherein the catheter defines a main flush port in fluid communication with the lumen, the main flush port is configured and arranged for inputting the acoustically-favorable medium to the lumen.

16. The intravascular ultrasound imaging system of claim **15**, wherein the movable plunger or the movable seal is disposed in the main flush port.

17. The intravascular ultrasound imaging system of claim **14**, wherein the catheter defines an output port in fluid communication with the lumen, the at least one output port configured and arranged for flushing out gas from the lumen.

18. The intravascular ultrasound imaging system of claim **14**, wherein the catheter is sealed.

19. A method for forming a catheter of an intravascular ultrasound imaging system, the method comprising:

degassing a sealable lumen of the catheter comprising at least one transducer mounted to a driveshaft extending along at least a portion of a longitudinal length of the sealable lumen;

filling the sealable lumen with an acoustically-favorable medium through at least one flush port; and

sealing the lumen using a movable plunger or a movable seal in fluid communication with the sealable lumen, the movable seal or movable plunger configured and

arranged to adjust to changes in volume of the lumen to maintain the substantially degassed environment in the lumen.

20. The method of claim **19**, wherein sealing the lumen using the movable plunger or the movable seal in fluid communication with the sealable lumen comprises disposing the movable plunger or the movable seal in one of the at least one main flush ports.

* * * * *

专利名称(译)	具有填充有声学有利介质的密封导管的血管内超声成像系统以及制造和使用的方法		
公开(公告)号	US20090264769A1	公开(公告)日	2009-10-22
申请号	US12/425191	申请日	2009-04-16
[标]申请(专利权)人(译)	波士顿科学西美德公司		
申请(专利权)人(译)	BOSTON SCIENTIFIC SCIMED , INC.		
当前申请(专利权)人(译)	BOSTON SCIENTIFIC SCIMED , INC.		
[标]发明人	SADAKA ALAIN		
发明人	SADAKA, ALAIN		
IPC分类号	A61B8/14		
CPC分类号	A61B8/0833 A61B8/445 A61B8/4281 A61B8/12		
优先权	61/045904 2008-04-17 US		
其他公开文献	US9451929		
外部链接	Espacenet	USPTO	

摘要(译)

用于血管内超声系统的导管组件包括导管和成像核心。导管具有纵向长度，远端和近端。导管包括沿着导管的纵向长度从近端延伸到远端的可密封内腔，以及与内腔流体连通的可移动柱塞或可移动密封件。可移动柱塞或可移动密封件提供气密密封。可移动柱塞或可移动密封件被配置和布置成用于在内腔填充声学上有利的介质并密封时调节内腔体积的变化。成像芯被配置和布置成用于插入可密封的内腔中并且用于耦合到控制模块。

