



US010456105B2

(12) **United States Patent**
Lu et al.

(10) **Patent No.: US 10,456,105 B2**
(45) **Date of Patent: Oct. 29, 2019**

(54) **SYSTEMS AND METHODS WITH A SWELLABLE MATERIAL DISPOSED OVER A TRANSDUCER OF AN ULTRASOUND IMAGING SYSTEM**

(71) Applicant: **Boston Scientific SciMed, Inc.**, Maple Grove, MN (US)

(72) Inventors: **Xin Lu**, Palo Alto, CA (US); **Eric Elliott**, San Francisco, CA (US)

(73) Assignee: **BOSTON SCIENTIFIC SCIMED, INC.**, Maple Grove, MN (US)

(*) Notice: Subject to any disclaimer, the term of this patent is extended or adjusted under 35 U.S.C. 154(b) by 788 days.

(21) Appl. No.: **15/145,441**

(22) Filed: **May 3, 2016**

(65) **Prior Publication Data**
US 2016/0324502 A1 Nov. 10, 2016

Related U.S. Application Data

(60) Provisional application No. 62/157,385, filed on May 5, 2015.

(51) **Int. Cl.**
A61B 8/12 (2006.01)
A61B 8/00 (2006.01)

(52) **U.S. Cl.**
CPC **A61B 8/12** (2013.01); **A61B 8/4281** (2013.01); **A61B 8/445** (2013.01); **A61B 8/4483** (2013.01)

(58) **Field of Classification Search**
None
See application file for complete search history.

(56) **References Cited**

U.S. PATENT DOCUMENTS

4,817,015 A 3/1989 Insana et al.
4,858,124 A 8/1989 Lizzi et al.
(Continued)

FOREIGN PATENT DOCUMENTS

EP 1239774 A2 9/2002
EP 1739593 A1 1/2007
(Continued)

OTHER PUBLICATIONS

International Search Report & Written Opinion, International Application No. PCT/US2012/030707 dated Jun. 5, 2012, 11 pages.

(Continued)

Primary Examiner — Jason T Yen

(74) *Attorney, Agent, or Firm* — Lowe Graham Jones PLLC; Bruce E. Black

(57) **ABSTRACT**

A catheter assembly for an ultrasound system includes an elongated catheter for insertion into the cardiovascular system of a patient. The catheter includes a sheath that defines a lumen extending along the sheath. The catheter assembly also includes an imaging core for inserting into the lumen of the catheter. The imaging core includes an elongated, rotatable driveshaft and an imaging device coupled to the distal end of the driveshaft with rotation of the driveshaft causing a corresponding rotation of the imaging device. The imaging device includes at least one transducer for transforming applied electrical signals to acoustic signals and also for transforming received echo signals to electrical signals. The imaging core further includes a swellable material disposed on at least the at least one transducer and configured and arranged to rotate with rotation of the driveshaft and to swell upon exposure to a fluid.

15 Claims, 5 Drawing Sheets

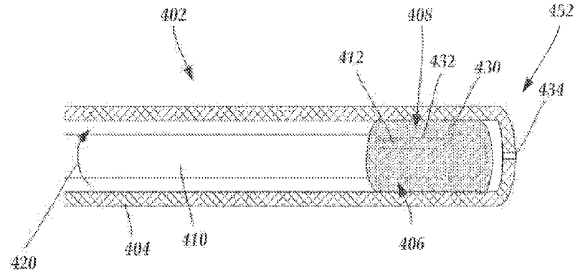
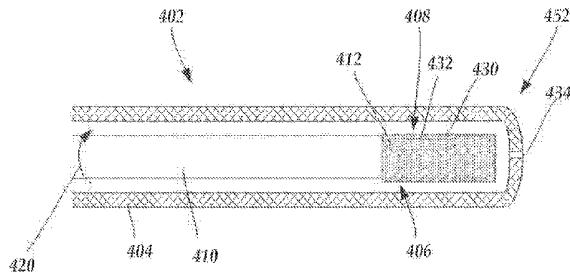

(56)

References Cited

U.S. PATENT DOCUMENTS

4,905,700 A 3/1990 Wokalek et al.
 5,081,993 A 1/1992 Kitney et al.
 5,115,814 A * 5/1992 Griffith A61B 5/06
 600/439
 5,375,602 A 12/1994 Lancee et al.
 5,400,785 A * 3/1995 Crowley A61B 8/12
 428/400
 5,406,951 A * 4/1995 ten Hoff A61B 8/12
 600/463
 5,497,770 A 3/1996 Morcos et al.
 6,019,724 A 2/2000 Gronningsaeter et al.
 6,192,360 B1 2/2001 Dumais et al.
 6,200,266 B1 3/2001 Vince et al.
 6,238,342 B1 5/2001 Feleppa et al.
 6,669,662 B1 * 12/2003 Webler A61B 8/12
 604/151
 6,945,938 B2 9/2005 Grunwald
 7,037,271 B2 5/2006 Crowley
 7,074,188 B2 7/2006 Nair et al.
 7,175,597 B2 2/2007 Vince et al.
 7,245,789 B2 7/2007 Bates et al.
 7,246,959 B2 7/2007 Nakatani
 7,306,561 B2 12/2007 Sathyanarayana
 7,447,388 B2 11/2008 Bates et al.
 7,622,853 B2 11/2009 Rehrig et al.
 7,672,706 B2 3/2010 Sathyanarayana
 7,729,533 B2 6/2010 Sathyanarayana
 7,892,175 B2 2/2011 Wakabayashi et al.
 2003/0220556 A1 11/2003 Porat et al.
 2004/0067000 A1 4/2004 Bates et al.
 2004/0146201 A1 7/2004 Sathyanarayana
 2004/0254463 A1 12/2004 Lehman
 2005/0043614 A1 2/2005 Huizenga et al.
 2005/0065426 A1 3/2005 Porat et al.
 2005/0154315 A1 7/2005 Nair et al.
 2005/0203410 A1 9/2005 Jenkins
 2005/0228254 A1 10/2005 Torp et al.
 2005/0249391 A1 11/2005 Kimmel et al.
 2005/0251116 A1 11/2005 Steinke et al.
 2006/0041199 A1 2/2006 Elmaleh et al.
 2006/0056703 A1 3/2006 Sathyanarayana
 2006/0058622 A1 3/2006 Tearney
 2006/0058653 A1 3/2006 Sathyanarayana
 2006/0100522 A1 5/2006 Yuan
 2006/0106320 A1 5/2006 Barbato
 2006/0120608 A1 6/2006 Luo et al.
 2006/0173350 A1 8/2006 Yuan
 2006/0222221 A1 10/2006 Sathyanarayana
 2006/0235286 A1 10/2006 Stone et al.
 2006/0253028 A1 11/2006 Lam
 2006/0271040 A1 11/2006 Horne et al.
 2006/0277998 A1 12/2006 Masotti
 2007/0003116 A1 1/2007 Yuan et al.
 2007/0005356 A1 1/2007 Perronnin
 2007/0016054 A1 1/2007 Cao
 2007/0038111 A1 2/2007 Rehg et al.
 2007/0049827 A1 3/2007 Donaldson
 2007/0055153 A1 3/2007 Simopoulos et al.
 2007/0078500 A1 4/2007 Ryan et al.
 2007/0083111 A1 4/2007 Hossack et al.
 2007/0100239 A1 5/2007 Nair et al.
 2007/0127789 A1 6/2007 Hoppel et al.
 2007/0133925 A1 6/2007 Bates et al.
 2007/0160275 A1 7/2007 Sathyanarayana
 2007/0165920 A1 7/2007 Gering et al.
 2007/0237371 A1 10/2007 Zhu et al.
 2007/0260141 A1 11/2007 Margolis et al.
 2007/0265521 A1 11/2007 Redel et al.
 2007/0282202 A1 12/2007 Maurice et al.
 2007/0299343 A1 12/2007 Waters
 2008/0039830 A1 2/2008 Munger et al.
 2008/0063265 A1 3/2008 Sathyanarayana
 2008/0125772 A1 5/2008 Kleymann
 2008/0234582 A1 9/2008 Nair et al.
 2008/0312673 A1 12/2008 Viswanathan et al.

2009/0059727 A1 3/2009 Bates et al.
 2009/0105579 A1 4/2009 Garibaldi
 2009/0137952 A1 5/2009 Ramamurthy et al.
 2009/0264769 A1 10/2009 Sadaka
 2009/0299195 A1 12/2009 Muller et al.
 2010/0249599 A1 * 9/2010 Hastings A61B 5/02007
 600/459
 2010/0249603 A1 9/2010 Hastings et al.
 2011/0009734 A1 * 1/2011 Foley A61N 7/02
 600/411
 2011/0071400 A1 3/2011 Hastings et al.
 2012/0108980 A1 * 5/2012 Shilling A61B 8/0883
 600/466
 2013/0123634 A1 * 5/2013 Tierney A61B 8/4281
 600/444
 2015/0148667 A1 * 5/2015 Mattrey A61B 8/481
 600/424

FOREIGN PATENT DOCUMENTS

EP 1780672 A1 5/2007
 JP 20110152274 A 8/2011
 JP 2014-064837 4/2014
 WO 9423652 A1 10/1994
 WO 9519135 A1 7/1995
 WO 9625881 A1 8/1996
 WO 9625882 A1 8/1996
 WO 9824065 A1 6/1998
 WO 9967728 A1 12/1999
 WO 2003075770 A1 9/2003
 WO 03096872 A2 11/2003
 WO 2004032746 A2 4/2004
 WO 2005033738 A1 4/2005
 WO 2005070300 A1 8/2005
 WO 2005071615 A1 8/2005
 WO 2005074804 A1 8/2005
 WO 2005107623 A2 11/2005
 WO 2006042077 A2 4/2006
 WO 2006105121 A2 10/2006
 WO 2006110830 A2 10/2006
 WO 2007041542 A2 4/2007
 WO 2007047404 A2 4/2007
 WO 2007047566 A2 4/2007
 WO 2007109771 A2 9/2007
 WO 2008022148 A2 2/2008
 WO 2008049084 A2 4/2008
 WO 2008107905 A2 9/2008
 WO 2009023626 A1 2/2009
 WO 2009023801 A1 2/2009
 WO 2009121067 A1 10/2009

OTHER PUBLICATIONS

Watson et al., "Classification of Arterial Plaque by Spectral Analysis of in Vitro Radio Frequency Intra Vascular Ultrasound Data," *UltraSound in Med. & Biol.*, vol. 26 No. 1, pp. 73-80, 2000.
 McLeod, Andrew L, et al., "Classification of Arterial Plaque by Spectral Analysis in Remodelled Human Atherosclerotic Coronary Arteries," *Ultrasound in Med. & Biol.*, (2004) vol. 30, No. 2, pp. 155-159.
 Official Communication for U.S. Appl. No. 12/563,754 dated Jun. 6, 2012, 43 pages.
 Official Communication for U.S. Appl. No. 12/563,754 dated Dec. 31, 2012, 11 pages.
 Official Communication for U.S. Appl. No. 12/563,754 dated May 22, 2013, 15 pages.
 Kawaguchi et al. Usefulness of Virtual Histology Intravascular Ultrasound to Predict Distal Embolization for ST—Segment Elevation Myocardial Infarction, *Journal of the American College of Cardiology*, vol. 50, No. 17, pp. 1641-1647, 2007.
 Caballero, et al. Using Reconstructed IVUS Images for Coronary Plaque Classification, *Proceedings of the 29th Annual International Conference of the IEEE EMBS*, Aug. 23-26, pp. 2167-2170, 2007.
 Sarkar, M. "Modular Pattern Classifiers: A Brief Survey" *Systems, Man, and Cybernetics*, 2000 IEEE International Conference in Nashville, TN, USA. vol. 4 pp. 2878-2883 (2000).

(56)

References Cited

OTHER PUBLICATIONS

Kittler, J. et al., "On Combining Classifiers," IEEE Transactions on Pattern Analysis and Machine Intelligence, Mar. 1998, 20(3):226-239.

Official Communication for U.S. Appl. No. 12/429,005 dated Feb. 14, 2012, 2 pages.

Official Communication for U.S. Appl. No. 12/429,005 dated Apr. 5, 2012, 5 pages.

Official Communication for U.S. Appl. No. 12/429,005 dated Jun. 29, 2012, 26 pages.

Official Communication for U.S. Appl. No. 12/429,005 dated Mar. 21, 2013, 31 pages.

Official Communication for U.S. Appl. No. 12/429,005 dated Nov. 9, 2011, 12 pages.

Official Communication for U.S. Appl. No. 12/429,005 dated Jun. 10, 2011, 10 pages.

International Search Report and Written Opinion for International Application No. PCT/US2016/030573 dated Aug. 4, 2016.

* cited by examiner

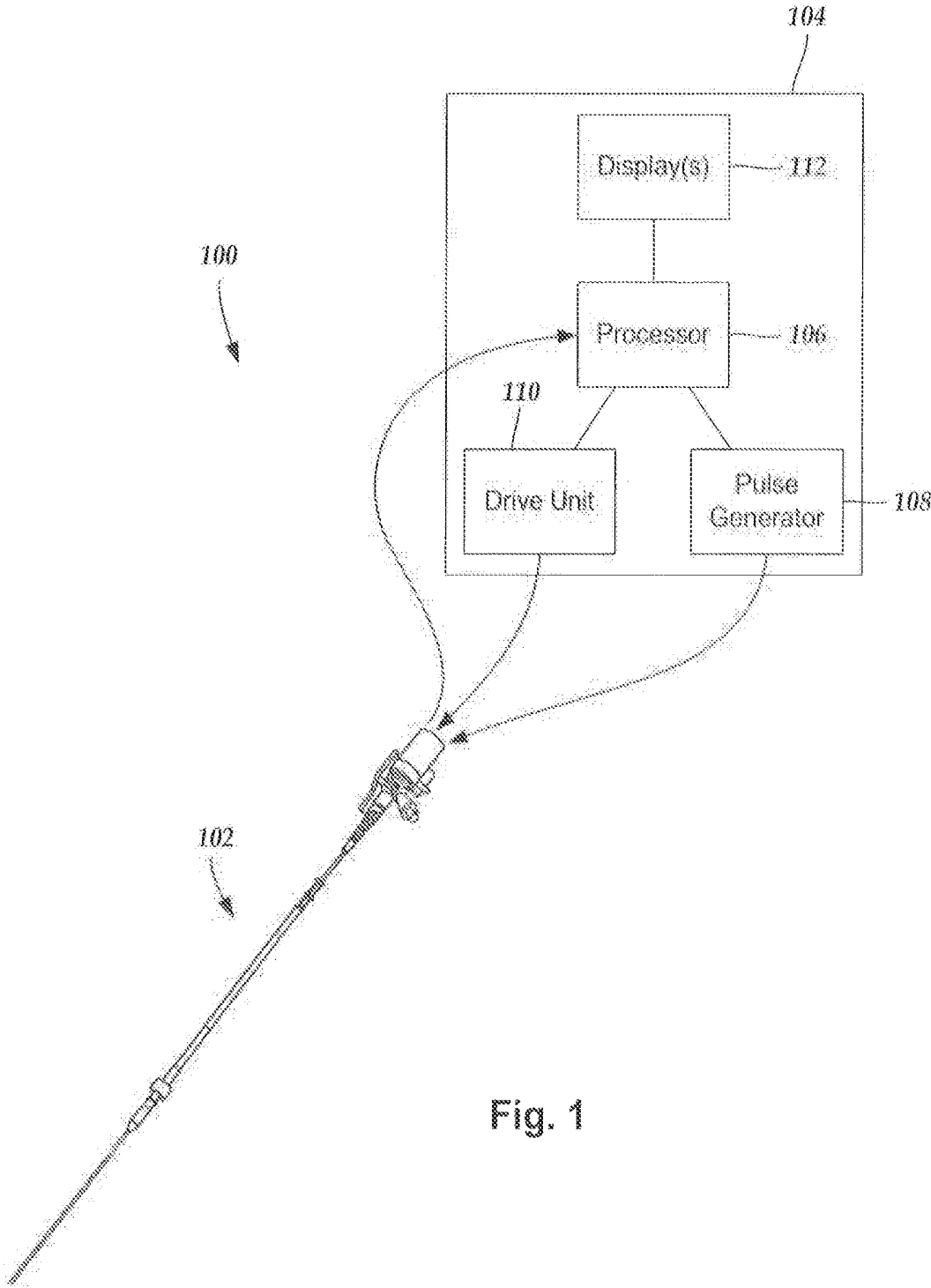

Fig. 1

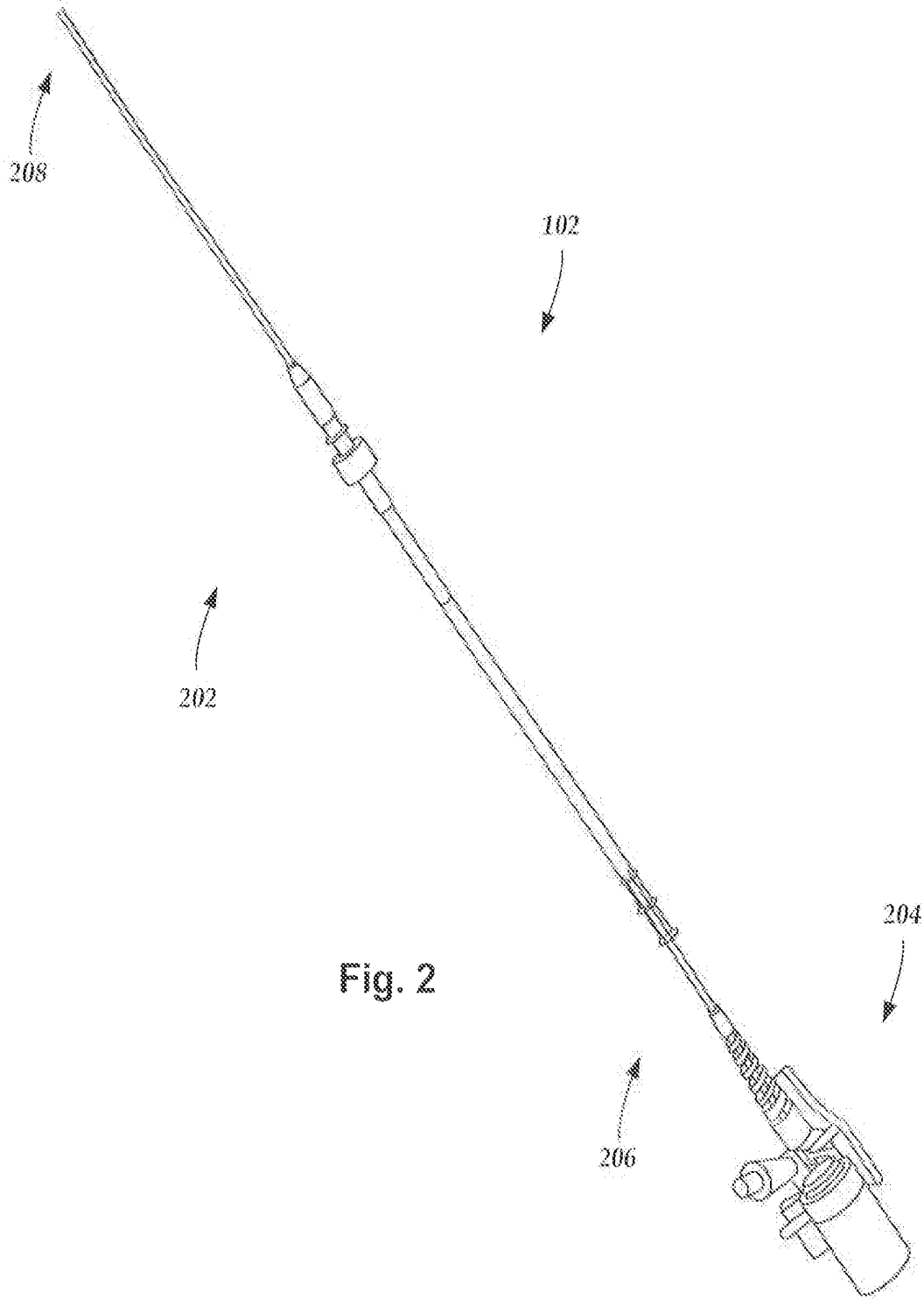

Fig. 2

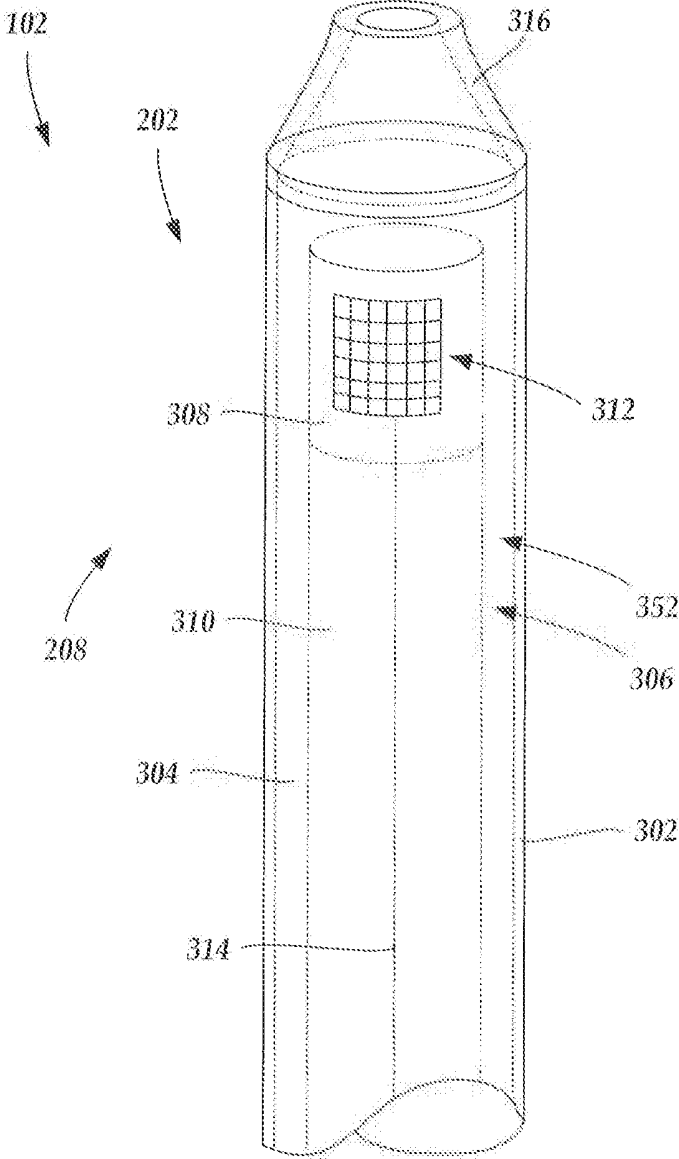

Fig. 3

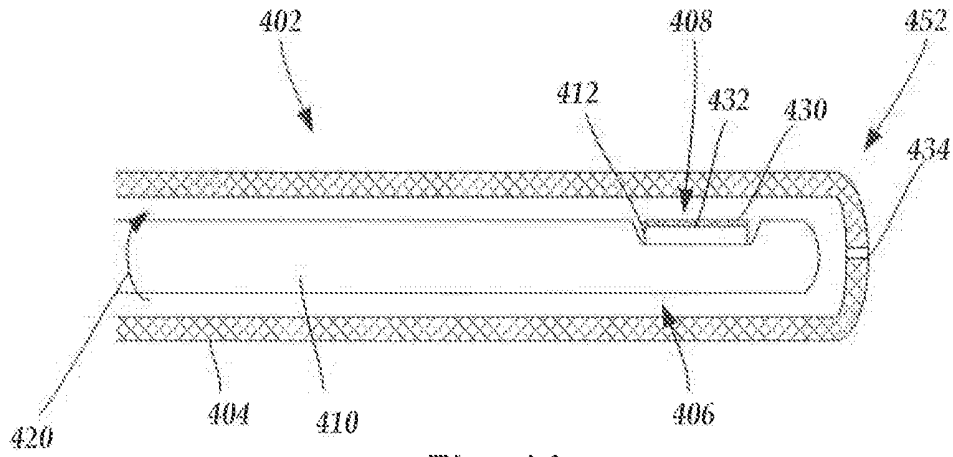

Fig. 4A

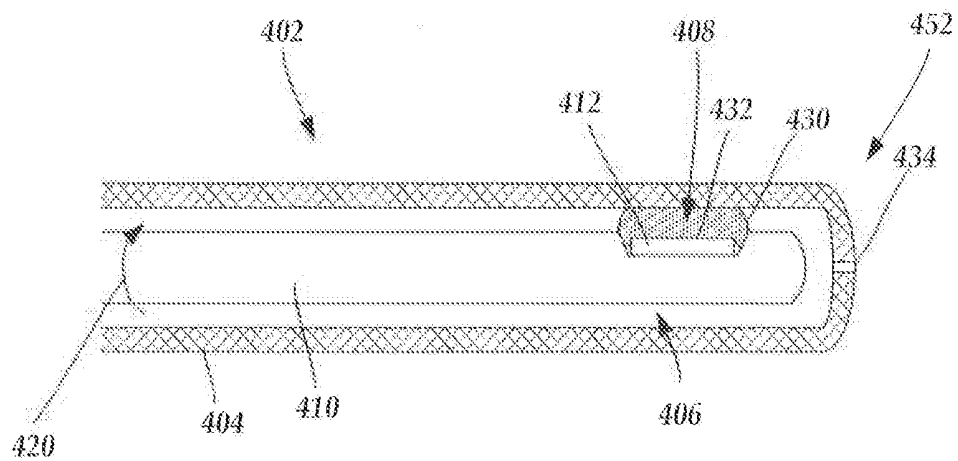

Fig. 4B

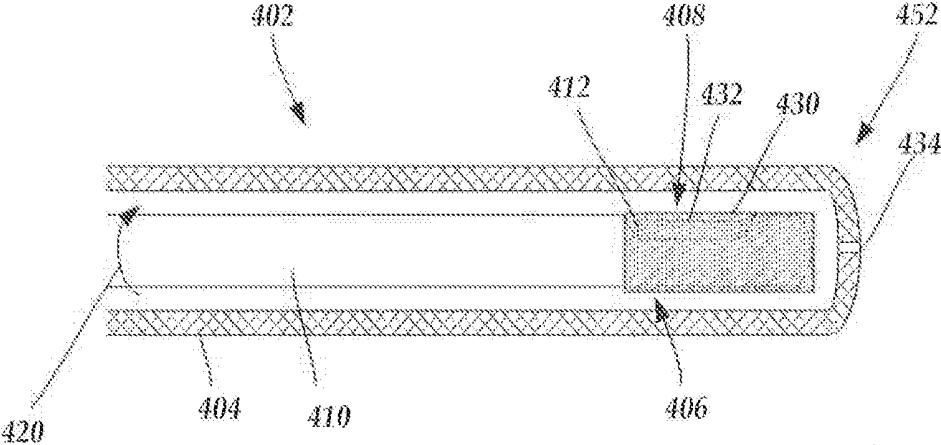

Fig. 5A

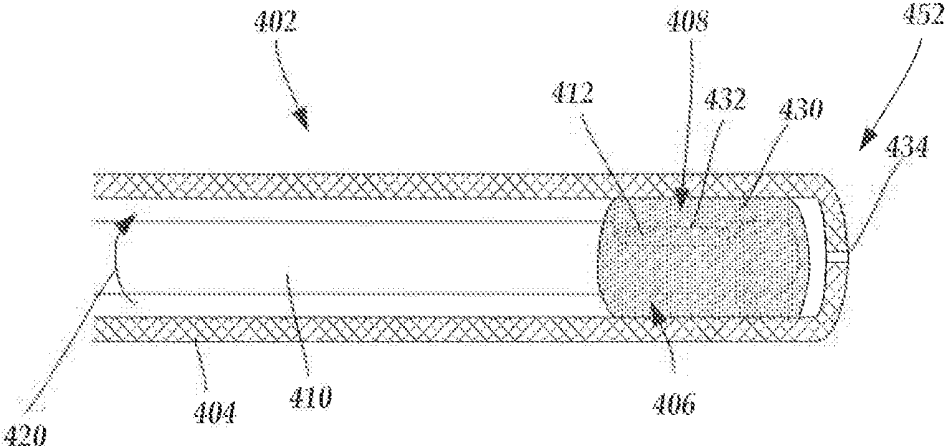

Fig. 5B

1

**SYSTEMS AND METHODS WITH A
SWELLABLE MATERIAL DISPOSED OVER
A TRANSDUCER OF AN ULTRASOUND
IMAGING SYSTEM**

**CROSS-REFERENCE TO RELATED
APPLICATIONS**

This application claims the benefit under 35 U.S.C. § 119(e) of U.S. Provisional Patent Application Ser. No. 62/157,385, filed May 5, 2015, which is incorporated herein by reference.

TECHNICAL FIELD

The present invention is directed to the area of ultrasound imaging systems and methods of making and using the systems. The present invention is also directed to an ultrasound imaging system that includes a transducer disposed within a catheter and a swellable material disposed over the transducer, as well as methods of making and using the ultrasound systems, catheter, and transducer.

BACKGROUND

Ultrasound devices insertable into patients have proven diagnostic capabilities for a variety of diseases and disorders. For example, intravascular ultrasound (“IVUS”) imaging systems have been used as an imaging modality for diagnosing blocked blood vessels and providing information to aid medical practitioners in selecting and placing stents and other devices to restore or increase blood flow. IVUS imaging systems have been used to diagnose atheromatous plaque build-up at particular locations within blood vessels. IVUS imaging systems can be used to determine the existence of an intravascular obstruction or stenosis, as well as the nature and degree of the obstruction or stenosis. IVUS imaging systems can be used to visualize segments of a vascular system that may be difficult to visualize using other intravascular imaging techniques, such as angiography, due to, for example, movement (e.g., a beating heart) or obstruction by one or more structures (e.g., one or more blood vessels not desired to be imaged). IVUS imaging systems can be used to monitor or assess ongoing intravascular treatments, such as angiography and stent placement in real (or almost real) time. Moreover, IVUS imaging systems can be used to monitor one or more heart chambers.

IVUS imaging systems have been developed to provide a diagnostic tool for visualizing a variety of diseases or disorders. An IVUS imaging system can include a control module (with a pulse generator, an image processor, and a monitor), a catheter, and one or more transducers disposed in the catheter. The transducer-containing catheter can be positioned in a lumen or cavity within, or in proximity to, a region to be imaged, such as a blood vessel wall or patient tissue in proximity to a blood vessel wall. The pulse generator in the control module generates electrical signals that are delivered to the one or more transducers and transformed to acoustic signals that are transmitted through patient tissue. Reflected signals of the transmitted acoustic signals are absorbed by the one or more transducers and transformed to electric signals. The transformed electric signals are delivered to the image processor and converted to an image displayable on the monitor.

Intracardiac echocardiography (“ICE”) is another ultrasound imaging technique with proven capabilities for use in diagnosing intravascular diseases and disorders. ICE uses

2

acoustic signals to image patient tissue. Acoustic signals emitted from an ICE imager disposed in a catheter are reflected from patient tissue and collected and processed by a coupled ICE control module to form an image. ICE imaging systems can be used to image tissue within a heart chamber.

BRIEF SUMMARY

One embodiment is a catheter assembly for an ultrasound system. The catheter assembly includes an elongated catheter configured and arranged for insertion into the cardiovascular system of a patient, the catheter having a distal end, a proximal end, and a longitudinal length. The catheter includes a sheath with a proximal portion and a distal portion and the sheath defines a lumen extending along the sheath from the proximal portion to the distal portion. The catheter assembly also includes an imaging core configured and arranged for inserting into the lumen of the catheter. The imaging core includes an elongated, rotatable driveshaft having a proximal end and a distal end and an imaging device coupled to the distal end of the driveshaft with rotation of the driveshaft causing a corresponding rotation of the imaging device. The imaging device includes at least one transducer configured and arranged for transforming applied electrical signals to acoustic signals and also for transforming received echo signals to electrical signals. The imaging core further includes a swellable material disposed on at least the at least one transducer and configured and arranged to rotate with rotation of the driveshaft and to swell upon exposure to a fluid. In at least some embodiments, the swellable material is swollen.

In at least some embodiments, the swellable material is configured and arranged to swell upon exposure to at least one of water, saline, or blood. In at least some embodiments, the swellable material is a hydrogel. In at least some embodiments, the swellable material is configured and arranged to swell and fill a space immediately between the transducer and the sheath so that acoustic signals from the transducer pass from the transducer through the swellable material and directly into the sheath. In at least some embodiments, the swellable material is configured and arranged to swell and fill at least 90% of a space immediately between the transducer and the sheath. In at least some embodiments, the swellable material is mechanically or chemically attached to the imaging core. In at least some embodiments, the swellable material, when swollen, is lubricious.

In at least some embodiments, the catheter assembly further includes a drive unit coupled to the driveshaft, the drive unit configured and arranged for controlling rotation of the driveshaft. In at least some embodiments, the catheter assembly further includes a control module coupled to the imaging core, the control module including a pulse generator electrically coupled to the imaging core, the pulse generator configured and arranged for providing electrical signals to the at least one transducer, and a processor electrically coupled to the imaging core, the processor configured and arranged for processing received electrical signals from the at least one transducer to form at least one image.

Another embodiment is an imaging device that includes at least one transducer configured and arranged for transforming applied electrical signals to acoustic signals and also for transforming received echo signals to electrical signals, and

a swellable material disposed on the at least one transducer. In at least some embodiments, the swellable material is swollen.

In at least some embodiments, the swellable material is configured and arranged to swell upon exposure to at least one of water, saline, or blood. In at least some embodiments, the swellable material is a hydrogel. In at least some embodiments, the swellable material is mechanically or chemically attached to the at least one transducer.

A further embodiment is a method of forming any of the catheter assemblies or imaging devices described above. The method includes providing the at least one transducer; and disposing the swellable material on at least the at least one transducer or the imaging core.

In at least some embodiments, disposing the swellable material on the at least one transducer includes coating the at least one transducer with the swellable material or a precursor of the swellable material. In at least some embodiments, the method also includes crosslinking or curing the swellable material or the precursor of the swellable material to mechanically or chemically couple the swellable material to the at least one transducer or the imaging core.

Yet another embodiment is a method of using any of the catheter assemblies described above. The method includes inserting the imaging core into the sheath of the catheter; exposing the swellable material to the fluid causing the swellable material to swell within the sheath; and rotating the driveshaft with the swellable material swollen within the sheath.

In at least some embodiments, exposing the swellable material to the fluid includes injecting water or saline into the sheath of the catheter. In at least some embodiments, exposing the swellable material to the fluid includes allowing blood to flow into the sheath of the catheter. In at least some embodiments, exposing the swellable material to the fluid includes swelling the swellable material to fill a space immediately between the transducer and the sheath so that acoustic signals from the transducer pass from the transducer through the swellable material and directly into the sheath.

BRIEF DESCRIPTION OF THE DRAWINGS

Non-limiting and non-exhaustive embodiments of the present invention are described with reference to the following drawings. In the drawings, like reference numerals refer to like parts throughout the various figures unless otherwise specified.

For a better understanding of the present invention, reference will be made to the following Detailed Description, which is to be read in association with the accompanying drawings, wherein:

FIG. 1 is a schematic view of one embodiment of an intravascular ultrasound imaging system, according to the invention;

FIG. 2 is a schematic side view of one embodiment of a catheter of an intravascular ultrasound imaging system, according to the invention;

FIG. 3 is a schematic perspective view of one embodiment of a distal end of the catheter shown in FIG. 2 with an imaging core disposed in a lumen defined in the catheter, according to the invention;

FIG. 4A is a schematic longitudinal cross-sectional view of one embodiment of the distal end of the catheter of FIG. 3 with a swellable material, prior to swelling, disposed over the transducer, according to the invention;

FIG. 4B is a schematic longitudinal cross-sectional view of the embodiment of FIG. 4A with the swellable material, after swelling, disposed over the transducer, according to the invention;

FIG. 5A is a schematic longitudinal cross-sectional view of a second embodiment of the distal end of the catheter of FIG. 3 with a swellable material, prior to swelling, disposed over the transducer and imaging core, according to the invention; and

FIG. 5B is a schematic longitudinal cross-sectional view of the embodiment of FIG. 5A with the swellable material, after swelling, disposed over the transducer and imaging core, according to the invention.

DETAILED DESCRIPTION

The present invention is directed to the area of ultrasound imaging systems and methods of making and using the systems. The present invention is also directed to an ultrasound imaging system that includes a transducer disposed within a catheter and a swellable material disposed over the transducer, as well as methods of making and using the ultrasound systems, catheter, and transducer.

Suitable ultrasound imaging systems utilizing catheters include, for example, intravascular ultrasound (“IVUS”) and intracardiac echocardiography (“ICE”) systems. These systems may include one or more transducers disposed on a distal end of a catheter configured and arranged for percutaneous insertion into a patient. Examples of IVUS imaging systems with catheters are found in, for example, U.S. Pat. Nos. 6,945,938; 7,246,959; and 7,306,561; as well as U.S. Patent Application Publication Nos. 2006/0100522; 2006/0106320; 2006/0173350; 2006/0253028; 2007/0016054; and 2007/0038111; all of which are incorporated herein by reference.

FIG. 1 illustrates schematically one embodiment of an IVUS imaging system **100**. An ICE imaging system is similar. The IVUS imaging system **100** includes a catheter **102** that is coupleable to a control module **104**. The control module **104** may include, for example, a processor **106**, a pulse generator **108**, a drive unit **110**, and one or more displays **112**. In at least some embodiments, the pulse generator **108** forms electric signals that may be input to one or more transducers (**312** in FIG. 3) disposed in the catheter **102**. In at least some embodiments, mechanical energy from the drive unit **110** may be used to drive an imaging core (**306** in FIG. 3) disposed in the catheter **102**.

In at least some embodiments, electrical signals transmitted from the one or more transducers (**312** in FIG. 3) may be input to the processor **106** for processing. In at least some embodiments, the processed electrical signals from the one or more transducers (**312** in FIG. 3) may be displayed as one or more images on the one or more displays **112**. In at least some embodiments, the processor **106** may also be used to control the functioning of one or more of the other components of the control module **104**. For example, the processor **106** may be used to control at least one of the frequency or duration of the electrical signals transmitted from the pulse generator **108**, the rotation rate of the imaging core (**306** in FIG. 3) by the drive unit **110**, the velocity or length of the pullback of the imaging core (**306** in FIG. 3) by the drive unit **110**, or one or more properties of one or more images formed on the one or more displays **112**.

FIG. 2 is a schematic side view of one embodiment of the catheter **102** of the IVUS imaging system (**100** in FIG. 1). The catheter **102** includes an elongated member **202** and a hub **204**. The elongated member **202** includes a proximal

end **206** and a distal end **208**. In FIG. 2, the proximal end **206** of the elongated member **202** is coupled to the catheter hub **204** and the distal end **208** of the elongated member is configured and arranged for percutaneous insertion into a patient. In some embodiments, the elongated member **202** and the hub **204** are formed as a unitary body. In other embodiments, the elongated member **202** and the catheter hub **204** are formed separately and subsequently assembled together.

FIG. 3 is a schematic perspective view of one embodiment of the distal end **208** of the catheter **102**. The catheter **102** includes a sheath **302** having a distal portion **352** and a proximal portion (not shown). The sheath **302** defines a lumen **304** extending along the sheath. An imaging core **306** is disposed in the lumen **304**. The imaging core **306** includes an imaging device **308** coupled to a distal end of a driveshaft **310**.

The sheath **302** may be formed from any flexible, bio-compatible material suitable for insertion into a patient. Examples of suitable materials include, for example, polyethylene, polyurethane, plastic, spiral-cut stainless steel, nitinol hypotube, and the like or combinations thereof.

One or more transducers **312** may be mounted to the imaging device **308** and employed to transmit and receive acoustic signals. In a preferred embodiment (as shown in FIG. 3), an array of transducers **312** are mounted to the imaging device **308**. In other embodiments, a single transducer may be employed. In at least some embodiments, multiple transducers in an irregular-array may be employed. Any number of transducers **312** can be used. For example, there can be one, two, three, four, five, six, seven, eight, nine, ten, twelve, fifteen, sixteen, twenty, twenty-five, fifty, one hundred, five hundred, one thousand, or more transducers. As will be recognized, other numbers of transducers may also be used.

The one or more transducers **312** may be formed from one or more known materials capable of transforming applied electrical signals into pressure distortions on the surface of the one or more transducers **312**, and vice versa. Examples of suitable materials include piezoelectric ceramic materials, piezocomposite materials, piezoelectric plastics, barium titanates, lead zirconate titanates, lead metaniobates, polyvinylidene fluorides, and the like.

The pressure distortions on the surface of the one or more transducers **312** form acoustic signals of a frequency based on the resonant frequencies of the one or more transducers **312**. The resonant frequencies of the one or more transducers **312** may be affected by the size, shape, and material used to form the one or more transducers **312**. The one or more transducers **312** may be formed in any shape suitable for positioning within the catheter **102** and for propagating acoustic signals of a desired frequency in one or more selected directions. For example, transducers may be disc-shaped, block-shaped, rectangular-shaped, oval-shaped, and the like. The one or more transducers may be formed in the desired shape by any process including, for example, dicing, dice and fill, machining, microfabrication, and the like.

In at least some embodiments, the one or more transducers **312** can be used to form a radial cross-sectional image of a surrounding space. Thus, for example, when the one or more transducers **312** are disposed in the catheter **102** and inserted into a blood vessel of a patient, the one more transducers **312** may be used to form a composite image of the walls of the blood vessel and tissue surrounding the blood vessel by stitching together a plurality of individual image frames.

The imaging core **306** is rotated about a longitudinal axis of the catheter **102** while being disposed in the distal portion **352** of the sheath **302**. As the imaging core **306** rotates, the one or more transducers **312** emit acoustic signal in different radial directions. When an emitted acoustic signal with sufficient energy encounters one or more medium boundaries, such as one or more tissue boundaries, a portion of the emitted acoustic signal is reflected back to the emitting transducer as an echo signal. Each echo signal that reaches a transducer with sufficient energy to be detected is transformed to an electrical signal in the receiving transducer. The one or more transformed electrical signals are transmitted to the control module (**104** in FIG. 1) where the processor **106** processes the electrical-signal characteristics to generate a displayable image frame of the imaged region based, at least in part, on a collection of information from each of the acoustic signals transmitted and the echo signals received. In at least some embodiments, the rotation of the one or more transducers **312** is driven by the drive unit **110** disposed in the control module (**104** in FIG. 1), via the driveshaft **310** extending along the sheath **302** of the catheter **102**.

As the one or more transducers **312** rotate about the longitudinal axis of the catheter **102** emitting acoustic signals, a plurality of image frames are formed that collectively form a composite radial cross-sectional image of a portion of the region surrounding the one or more transducers **312**, such as the walls of a blood vessel of interest and the tissue surrounding the blood vessel. In at least some embodiments, one or more of the image frames can be displayed on the one or more displays **112**. In at least some embodiments, the radial cross-sectional composite image can be displayed on the one or more displays **112**.

In at least some embodiments, the imaging core **306** may also move longitudinally (i.e., translate) along the blood vessel within which the catheter **102** is inserted so that a plurality of composite cross-sectional images may be formed into one or more larger composite images that include an axial length of the blood vessel. In at least some embodiments, during an imaging procedure the one or more transducers **312** may be retracted (i.e., pulled back) along the longitudinal length of the catheter **102**. In at least some embodiments, the catheter **102** includes at least one section that can be retracted during pullback of the one or more transducers **312**. In at least some embodiments, the drive unit **110** drives the pullback of the imaging core **306** within the catheter **102**. In at least some embodiments, the drive unit **110** pullback distance of the imaging core is at least 5 cm, 10 cm, 15 cm, 20 cm, 25 cm or more. In at least some embodiments, the catheter **102** pullback occurs along one or more telescoping sections.

The quality of imaging at different depths from the one or more transducers **312** may be affected by one or more factors including, for example, bandwidth, transducer focus, beam pattern, as well as the frequency of the acoustic signal. The frequency of the acoustic signal output from the one or more transducers **312** may also affect the penetration depth of the acoustic signal output from the one or more transducers **312**. In general, as the frequency of an acoustic signal is lowered, the depth of the penetration of the acoustic signal within patient tissue increases. In at least some embodiments, the IVUS imaging system **100** operates within a frequency range of 5 MHz to 60 MHz.

One or more transducer conductors **314** electrically couple the transducers **312** to the control module **104** (See FIG. 1). In at least some embodiments, the one or more transducer conductors **314** extend along the driveshaft **310**.

The imaging device **308** is inserted in the lumen of the catheter **102**. In at least some embodiments, the catheter **102** (and imaging device **308**) may be inserted percutaneously into a patient via an accessible blood vessel, such as the femoral artery or vein, at a site remote from a target imaging location. The catheter **102** may then be advanced through patient vasculature to the target imaging location, such as a portion of a selected blood vessel (e.g., a peripheral blood vessel, a coronary blood vessel, or other blood vessel), or one or more chambers of the patient's heart.

Acoustic signals propagating from the one or more transducers propagate through a portion of the lumen surrounding the imaging device before passing through the sheath to the region exterior of the catheter such as a blood vessel or a chamber of a heart. Likewise, echo signals reflected back to the one or more transducers from medium boundaries also propagate through a portion of the lumen. Typically, air is not a desirable transmission medium and image quality may, consequently, be reduced when acoustic signals or echo signals are required by catheter design to propagate through air. In the MHz range, acoustic signals may not propagate at all through air. Accordingly, it is typically advantageous, and in some cases necessary, to purge air from the lumen surrounding the one or more transducers prior to (or one or more times during) the performance of an imaging procedure.

One technique for purging air surrounding the one or more transducers is to flush the lumen with an acoustically-favorable medium, such as water or saline, through which acoustic signals more easily propagate than through air. When using a conventional IVUS imaging system, a lumen of a catheter can be manually flushed to remove air at the beginning of an IVUS imaging procedure. Additionally, the lumen of the catheter may also be manually flushed of air one or more additional times during the course of the IVUS imaging procedure. Unfortunately, each manual flushing of air from the catheter lumen can add to the amount of time it takes to perform an IVUS imaging procedure on a patient.

To reduce the need for repeated flushing during an imaging procedure, a swellable material can be disposed on the transducer. When exposed to fluid, such as water or saline, during, for example, preparation of the catheter for the imaging procedure, the swellable material swells to fill the space between the transducer and the sheath. This can provide an acoustically favorable transmission medium between the transducer and the sheath while eliminating or reducing air bubbles. In at least some embodiments, after the initial swelling of the swellable material there is no need during an imaging procedure to flush the catheter. Alternatively, additional fluid may be added during the imaging procedure to ensure that the swellable material remains swollen. In at least some embodiments, the swellable material is already swollen prior to beginning the imaging procedure or during preparation for the imaging procedure.

FIGS. **4A** and **4B** are schematic longitudinal cross-sectional views of one embodiment of a distal end **452** of a catheter **402**. FIGS. **5A** and **5B** illustrate a second embodiment of a distal end **452** of a catheter **402**. In both embodiments, the catheter **402** includes a sheath **404** and a lumen **406** with an optional flush port **434**. In both embodiments, the imaging core **408** is shown disposed in the lumen **406** of the sheath **404** at a distal portion **452** of the sheath **404**. The imaging core **408** includes a rotatable driveshaft **410** with one or more transducers **412** coupled to a distal end of the driveshaft **410**. The rotatable driveshaft **410** rotates the one or more transducers as illustrated by arrow **420**.

A swellable material **430** is disposed on at least the one or more transducers **412**. FIGS. **4A** and **5A** illustrate the swellable material **430** prior to swelling and FIGS. **4B** and **5B** illustrates the swellable material **430** after swelling. The swellable material **430** in the embodiment of FIGS. **4A** and **4B** is disposed on at least the acoustically active surface **432** of the one or more transducer **412** from which acoustic signals are emitted and received. In the embodiment of FIGS. **5A** and **5B**, the swellable material **430** is disposed over a portion of the imaging core **408** including the one or more transducers **412** and extending around the entire circumference of the core and may even extend over the distal end of the imaging core. It will be understood that other variations of the coverage of the swellable material **430** over the imaging core intermediate between the two illustrated embodiments can also be used, as well as variations where the swellable material extends further proximally or distally from the regions in the illustrated embodiments. Preferably, the swellable material **430** is disposed over at least the acoustically active surface **432** of the one or more transducer **412** and may extend over more of the imaging core **408** and further along the lumen **406** of the sheath **404**.

In at least some embodiments, the swellable material **430** rotates, even when swollen, with the one or more transducers **412** upon rotation of the driveshaft **410**. In some embodiments, a swellable material **430** is selected so that the swellable material, when swollen, forms a lubricious surface that facilitates rotation of the swellable material against the inner surface of the sheath **404**. In at least some embodiments, the swellable material **430**, when swollen, maintains structural integrity formed in the shape of the catheter lumen **406**.

The swellable material **430** can be swollen using a fluid such as, for example, water, saline, or blood. In at least some embodiments, the fluid enters the catheter **402** during a flushing or other procedure. Alternatively or additionally, a fluid, such as blood, can enter the catheter **402** through flush port **434** or other port to swell the swellable material **430**. In at least some embodiments, the swellable material **430** is swollen during manufacture and remains swollen thereafter.

As the swellable material **430** swells, the material displaces air bubbles within the lumen **406** of the catheter **402**. Preferably, when the swellable material **430** is swollen, the material contacts the inner wall of the sheath **404**. In other embodiments, the swellable material **430** fills at least 50%, 66%, 75%, 80%, 90%, 95%, or 99% of the space between the sheath **404** and the acoustically active surface **432** of the one or more transducer **412**.

Any suitable swellable material can be used including, but not limited to, hydrogels which are often a hydrophilic network of polymer chains. Often, the polymer chains of a hydrogel are crosslinked, cured, or otherwise arranged to form the network. For example, a hydrogel can include covalent crosslinking between polymer chains, coordinate bonding between polymer chains and inorganic particles, or the like, or any combination thereof. Examples of suitable hydrogels include, but are not limited to, polyvinyl alcohol, acrylamide nano-composite hydrogel, polyvinylpyrrolidone hydrogel, or the like. A nano-composite hydrogel is a polymeric network reinforced with nanoparticles. Preferably, the swellable material is biocompatible for at least the length of time that the catheter is expected to be in contact with patient tissue (for example, at least 1, 2, 4, 8, 12, or 24 hours). In at least some embodiments, the swellable material is acoustically transparent.

In at least some embodiments, the swellable material **430**, or one or more precursors of the swellable material, are

coated, or otherwise disposed, onto the transducer 412 (for example, on the acoustically active surface 432) and then cross-linked or cured to mechanically or chemically adhere the swellable material to the transducer.

The above specification, examples and data provide a description of the manufacture and use of the composition of the invention. Since many embodiments of the invention can be made without departing from the spirit and scope of the invention, the invention also resides in the claims hereinafter appended.

What is claimed as new and desired to be protected by Letters Patent of the United States is:

1. A method of using a catheter assembly, the method comprising:

providing a catheter assembly comprising

an elongated catheter configured and arranged for insertion into a cardiovascular system of a patient, the catheter having a distal end, a proximal end, and a longitudinal length, the catheter comprising a sheath with a proximal portion and a distal portion, the sheath defining a lumen extending along the sheath from the proximal portion to the distal portion, and

an imaging core configured and arranged for inserting into the lumen of the catheter, the imaging core comprising

an elongated, rotatable driveshaft having a proximal end and a distal end,

an imaging device coupled to the distal end of the driveshaft with rotation of the driveshaft causing a corresponding rotation of the imaging device, the imaging device comprising at least one transducer configured and arranged for transforming applied electrical signals to acoustic signals and also for transforming received echo signals to electrical signals, and

a swellable material disposed on at least the at least one transducer and configured and arranged to rotate with rotation of the driveshaft and to swell upon exposure to a fluid;

inserting the imaging core into the sheath of the catheter; exposing the swellable material to the fluid causing the swellable material to swell within the sheath; and rotating the driveshaft with the swellable material swollen within the sheath.

2. The method of claim 1, wherein exposing the swellable material to the fluid comprises injecting water or saline into the sheath of the catheter.

3. The method of claim 1, wherein exposing the swellable material to the fluid comprises allowing blood to flow into the sheath of the catheter.

4. The method of claim 1, wherein exposing the swellable material to the fluid comprises swelling the swellable material to fill a space immediately between the at least one transducer and the sheath so that acoustic signals from the at least one transducer pass from the at least one transducer through the swellable material and directly into the sheath.

5. The method of claim 1, wherein the swellable material is mechanically or chemically attached to the imaging core.

6. The method of claim 1, wherein the swellable material, when swollen, is lubricious.

7. The method of claim 1, wherein the swellable material is configured and arranged to swell upon exposure to at least one of water, saline, or blood.

8. The method of claim 1, wherein the swellable material is a hydrogel.

9. The method of claim 1, wherein the swellable material is configured and arranged to swell and fill at least 90% of a space immediately between the at least one transducer and the sheath.

10. The method of claim 1, wherein the catheter assembly further comprises a drive unit coupled to the driveshaft, the drive unit configured and arranged for controlling rotation of the driveshaft.

11. The method of claim 1, wherein the catheter assembly further comprises a control module coupled to the imaging core.

12. The method of claim 11, wherein the control module comprises a pulse generator electrically coupled to the imaging core, the pulse generator configured and arranged for providing electrical signals to the at least one transducer.

13. The method of claim 12, wherein the control module further comprises a processor electrically coupled to the imaging core, the processor configured and arranged for processing received electrical signals from the at least one transducer to form at least one image.

14. The method of claim 1, wherein the swellable material is coated on the at least one transducer.

15. The method of claim 1, wherein the swellable material is crosslinked on the at least one transducer to mechanically or chemically couple the swellable material to the imaging core.

* * * * *

| | | | |
|----------------|--|---------|------------|
| 专利名称(译) | 具有在超声成像系统的换能器上方布置的可溶胀材料的系统和方法 | | |
| 公开(公告)号 | US10456105 | 公开(公告)日 | 2019-10-29 |
| 申请号 | US15/145441 | 申请日 | 2016-05-03 |
| [标]申请(专利权)人(译) | 波士顿科学西美德公司 | | |
| 申请(专利权)人(译) | BOSTON SCIENTIFIC SCIMED , INC. | | |
| 当前申请(专利权)人(译) | BOSTON SCIENTIFIC SCIMED , INC. | | |
| [标]发明人 | LU XIN ELLIOTT ERIC | | |
| 发明人 | LU, XIN ELLIOTT, ERIC | | |
| IPC分类号 | A61B8/12 A61B8/00 | | |
| CPC分类号 | A61B8/12 A61B8/4483 A61B8/445 A61B8/4281 | | |
| 优先权 | 62/157385 2015-05-05 US | | |
| 其他公开文献 | US20160324502A1 | | |
| 外部链接 | Espacenet | | |

摘要(译)

用于超声系统的导管组件包括用于插入患者的心血管系统中的细长导管。导管包括护套，该护套限定了沿着护套延伸的内腔。导管组件还包括用于插入导管腔中的成像芯。成像芯包括细长的，可旋转的驱动轴和随着驱动轴的旋转而耦合到驱动轴的远端的成像装置，从而引起成像装置的相应旋转。该成像设备包括至少一个换能器，该换能器用于将施加的电信号转换为声信号并且还用于将接收到的回波信号转换为电信号。成像芯还包括可溶胀材料，该可溶胀材料设置在至少至少一个换能器上，并且被配置和布置成随着驱动轴的旋转而旋转并且在暴露于流体时溶胀。

