



US006478740B2

(12) **United States Patent**
Souney et al.

(10) **Patent No.:** **US 6,478,740 B2**
(45) **Date of Patent:** **Nov. 12, 2002**

(54) **PORTABLE HAND-CARRY SATELLITE
DIAGNOSTIC ULTRASOUND SYSTEM FOR
GENERAL AND CARDIAC IMAGING**

(58) **Field of Search** 600/437, 438,
600/443, 459, 460

(75) **Inventors:** **Sean Souney**, 230 Madeline Dr.
Lincoln Ave., Pasadena, CA (US)
91105; **Richard W. Roeder**, Tustin, CA
(US)

(56) **References Cited**

U.S. PATENT DOCUMENTS

5,758,649 A * 6/1998 Iwashita et al. 600/459
5,984,880 A * 11/1999 Lander et al. 600/595

(73) **Assignee:** **Sean Souney**, Pasadena, CA (US)

* cited by examiner

(*) **Notice:** Subject to any disclaimer, the term of this
patent is extended or adjusted under 35
U.S.C. 154(b) by 0 days.

Primary Examiner—Francis J. Jaworski
Assistant Examiner—Maulin Patel

(57) **ABSTRACT**

(21) **Appl. No.:** **09/964,722**

An ultrasound imaging system **18** for the generation of
image data at a first location **16** that sends said data to a main
ultrasound diagnostic imaging machine **10** for processing or
viewing of the image data. The data may be processed up to
the capabilities of the main machine **10** and then formatted
in the format capabilities of the main machine **10** (duplex
scan, color enhanced images, etc.) where the digital data can
be sent via hard wire or wireless transmission to a network
for viewing (image or processed data) or to the portable hand
carry satellite ultrasound imaging machine.

(22) **Filed:** **Sep. 26, 2001**

(65) **Prior Publication Data**

US 2002/0040186 A1 Apr. 4, 2002

Related U.S. Application Data

(60) Provisional application No. 60/235,481, filed on Sep. 26,
2001.

(51) **Int. Cl.⁷** **A61B 8/00**

(52) **U.S. Cl.** **600/437**

1 Claim, 2 Drawing Sheets

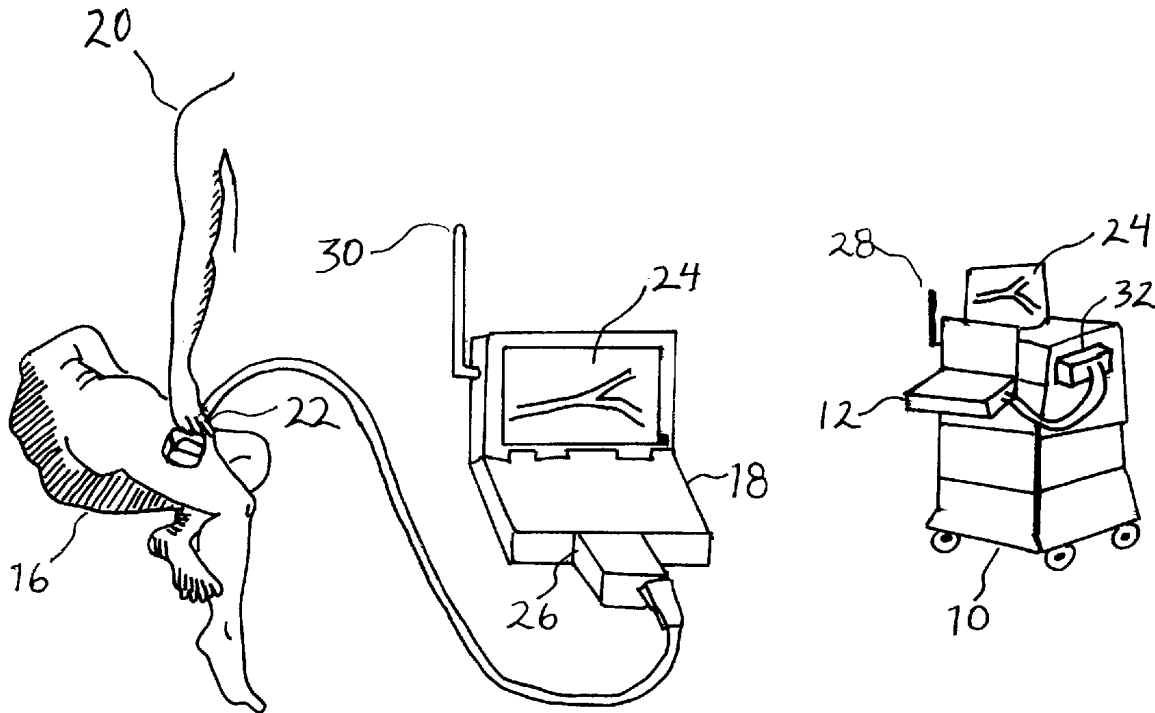

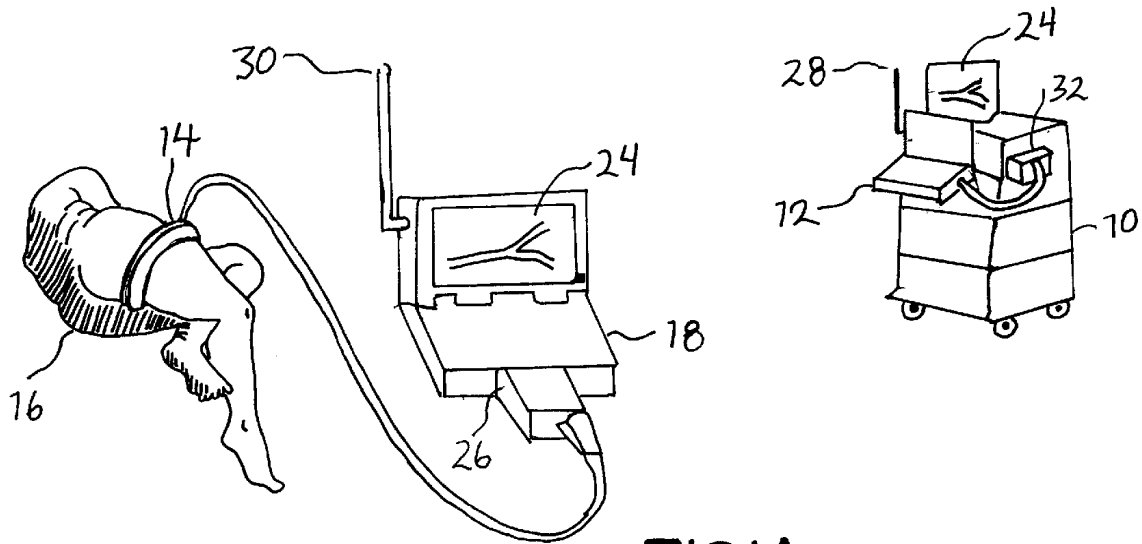

FIG. 1A

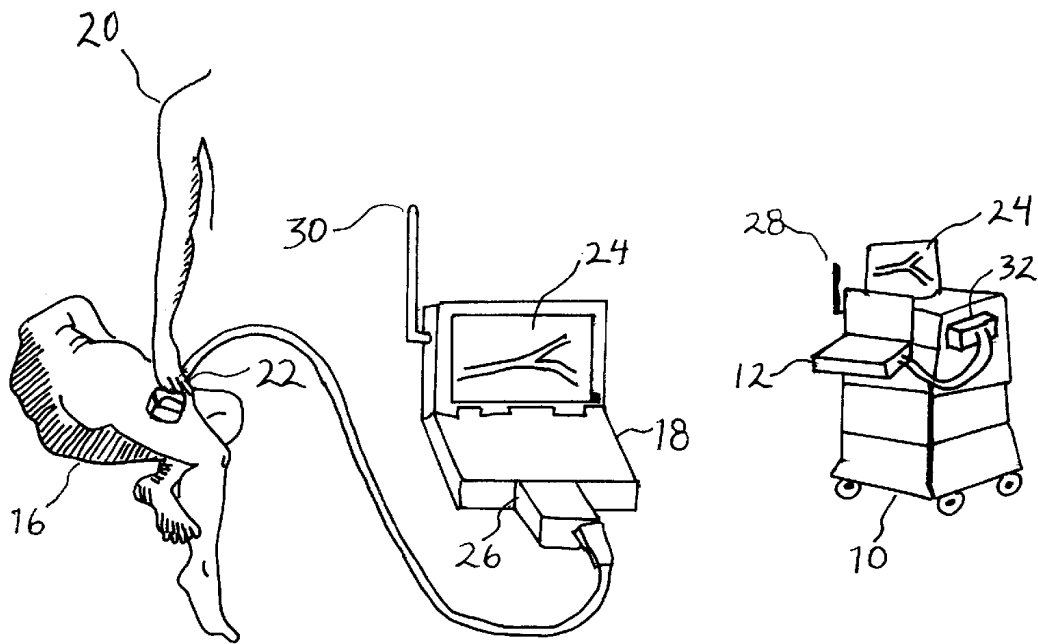

FIG. 1B

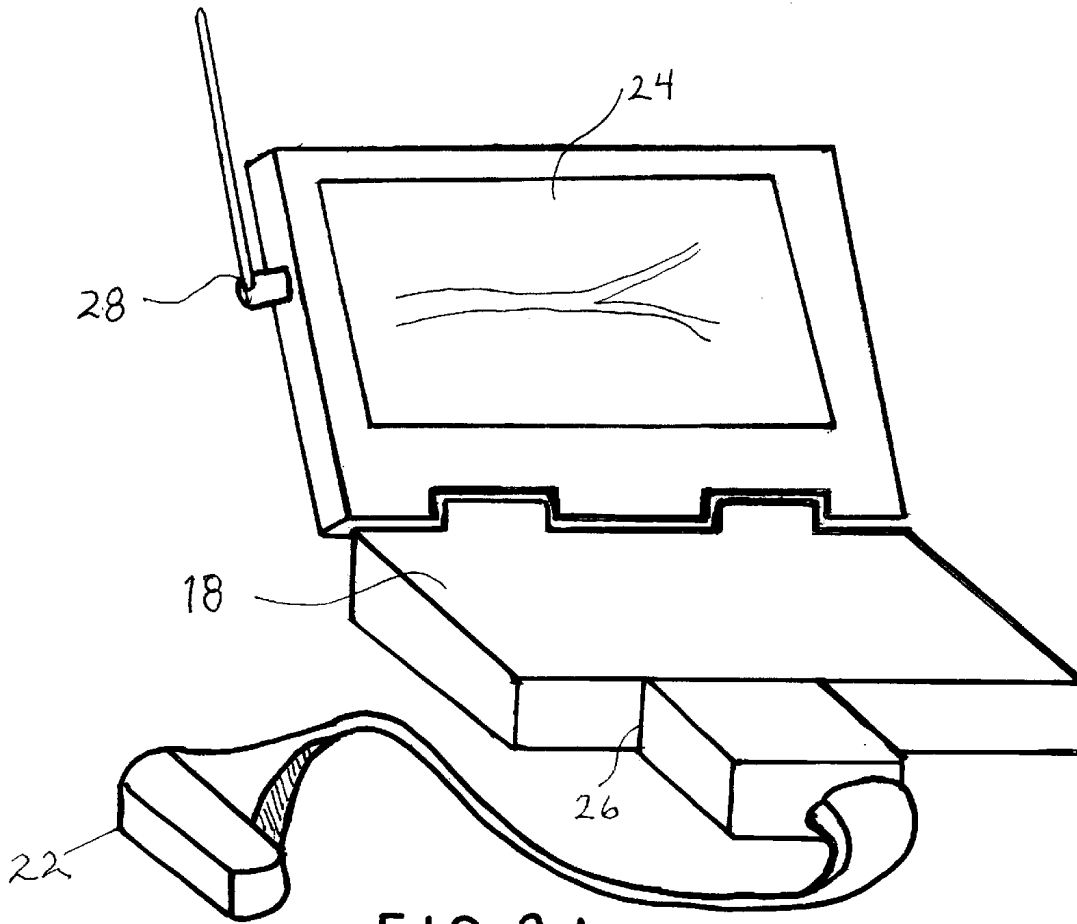

FIG. 2A

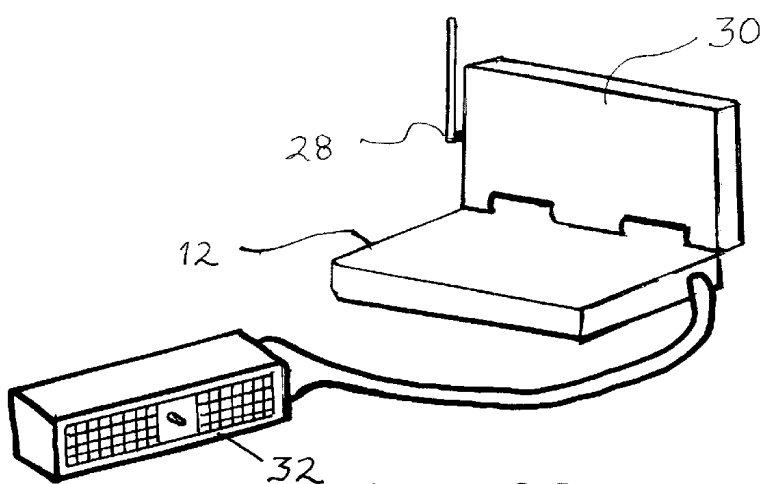

FIG. 2B

1

**PORTABLE HAND-CARRY SATELLITE
DIAGNOSTIC ULTRASOUND SYSTEM FOR
GENERAL AND CARDIAC IMAGING**

This application claims the benefit of U.S. provisional 5
Application No. 60/235,481, filed Sep. 26, 2001.

FEDERALLY SPONSORED RESEARCH

Not Applicable

SEQUENCE LISTING OR PROGRAM

Not Applicable

BACKGROUND—Field of Invention

This invention relates to diagnostic ultrasound, specifi- 15
cally to the machinery and the software processes that allow
data processing and communication of the processed data
between the main ultrasonic diagnostic imaging machine
(UDIM) and the portable hand carry satellite (peripheral)
imaging machine.

BACKGROUND—Description of Prior Art

Patients requiring diagnostic ultrasound must be physi- 25
cally brought to the large wheeled ultrasonic imaging
machine or the large wheeled ultrasonic imaging machine
must be physically brought to the patient's bedside. The
smallest of the units which are able to process image
information into diagnostic information, i.e. duplex scan-
ning (spectral doppler imaging) and that have features which
are diagnostic in nature, i.e. color flow imaging, three
dimensional imaging, etc. is over three hundred pounds and
still must travel in a specially made van between hospitals
and requires large very expensive crates when moved by rail
or plane.

The reason for this is that the amount of data that is 35
processed is great and even with the advances in surface
mount electronics, microelectronics and wireless
technology, the current data processing capabilities of these
units which include features such as duplex scanning
(spectral doppler) can not be miniaturized to the point that
they will fit in a hand held unit and generate the data
processing and analysis to make the digitized image of any
value to a physician, other than the image itself and basic
command functions that a coupled medical diagnostic imag-
ing system can have with an ultrasound peripheral. 45

U.S. Pat. No. 5,891,035 discloses an imaging system 50
capable of accessing images and information from internal
or external databases by means of a browser. This access
may be over a local network or over a worldwide network
such as the Internet. The browser may be used to pull in
system preset data or reference images from a reference
image library. This only helps as a comparative visual
reference to an image that one may request to view in
relation to a live image currently being viewed.

U.S. Pat. No. 5,384,494 describes the ability of an ultra- 55
sound system to control via wireless command the periph-
eral system and U.S. Pat. No. 6,120,447 deals with image
transmission through the use of a computer and routing
device.

None of the above mentioned patents describe the inven- 60
tion and its software processes which allow the satellite
imaging unit to essentially function at the same level of data
processing complexity as the host UDIM.

OBJECTS AND ADVANTAGES

Accordingly, the objects and advantages of the present 65
invention are:

2

- (a) to provide a satellite ultrasonic imaging machine that is
hand carried and has the ability of sending the ultrasonic
image data by digitally compressing it and sending it to
the main UDIM for processing and then returning the
processed data which will give complex information
which includes but is not limited to duplex scanning
(spectral doppler) images or statistical data related to the
ultrasonic image.
 - (b) To provide a motorized mechanical transducer probe the
movement of said probe can be commanded or moved
(linearly or rotated) about an area which it has circum-
scribed on a limb or body part allowing movement
commands from a main UDIM to change viewing images
at a peripheral site through probe movements.
 - (c) the use of a satellite device of this type allow complex
scans to be received after their image data is processed
with a portable device allowing rapid response time to
physicians requests and greater flexibility in scheduling
time (time and cost savings).
 - (d) The reduction of liability to the patient and the main
UDIM because, again, neither the patient has to be moved
to the UDIM or vice versa.
 - (e) The technical training level of the application specialist
can be reduced
 - (f) The treatment time can be minimized due to its simplified
application.
 - (g) the relief of the highly trained and limited number of
RVT's and/or physicians at the main UDIM of difficult
and many times impossible travel and setup time at the
patient's location.
 - (h) The extremely difficult physical problems of transporting
a large piece of equipment to the patient's bedside are
negated.
 - (i) Complex imaging and data processing features are avail-
able at any location that a hand carried unit can travel
(emergency field rescues, home or job site emergencies).
 - (j) The patient is more content and less anxious because of
the improved convenience.
 - (k) The diagnosis is completed rapidly and at less expense,
with a greater and more complex analysis which would
reduce patient mortality and long term treatment of
venous and arterial illnesses.
 - (l) With the reduction of educational requirements of the
ultrasound technician (as the data can be processed by
anyone in real time or at a later time) transport/setup time
are reduced and overall treatment costs are reduced.
 - (m) Features such as high definition imaging, color pulsed
doppler, greater than 256 gray shade 2 dimensional
imaging, color values from a 24 bit palette, digital coher-
ent processing(phase and amplitude information to opti-
mize resolution and frame rate), and spectral doppler
processing are accessible on the screen of the peripheral
unit.
 - (n) because of the portability of our satellite unit, accurate
and complex venous screening for Deep Vein Thrombosis
(Venous thromboembolism) and the resultant life threat-
ening pulmonary embolism before surgery and through-
out the patients risk period can now be performed at
minimal cost and time and with lifesaving results whereas
now this type of screening is avoided entirely for logis-
tical and financial reasons.
- Still further objects and advantages will become apparent
from a consideration of the ensuing description and draw-
ings.

SUMMARY

In accordance with the present invention a portable hand-
carry satellite diagnostic ultrasound system for general and

cardiac imaging comprises an ultrasound imaging machine, a satellite monitor which contains a CPU to digitize data for transmission, a satellite sending/receiving unit which functions as an airport for wireless or hardwire transmissions, and a main UDIM machine which also has a sending/receiving unit attached to the probe interface for the transmission or reception of wireless or hardwired data to or from the UDIM.

DRAWINGS

Drawing Figures

In the drawings, closely related figures have the same number but different alphabetic suffixes.

FIGS. 1A and 1B show the main aspects of the hand carried satellite ultrasonic imaging machine in relation to the main Ultrasonic Diagnostic Imaging Machine (UDIM) shown both with a manual and a motorized transducer probe.

FIGS. 2A and 2B show the hand-carried portable satellite ultrasonic imaging machine and satellite sending/receiving unit which are used to move the data between the two machines (portable and main ultrasonic imaging machine).

REFERENCE NUMERALS IN DRAWINGS

10 main UDIM (Ultrasonic diagnostic imaging machine)	12 base station for receiving/sending transmissions of data
14 probe transducer motorized	16 patient
18 hand carried portable ultrasonic imaging machine	20 imaging technician
22 probe transducer manual	24 display monitor
26 transducer probe hardwire connection	28 sending or receiving port (wireless or hardwired)
30 satellite sending/receiving unit	32 connection to UDIM probe

DETAILED DESCRIPTION

DESCRIPTION—FIGS. 1A and 1B—Preferred Embodiment

A preferred embodiment of the hand carried portable satellite diagnostic ultrasound system (PSDUS) is illustrated in FIGS. 1A and 1B. The PSDUS is attached to a portable Central processing unit which is a computer which is responsible for taking the images from the probe, digitizing them and compressing them so they can be sent via the airport by wireless or hardwire transmission to the main UDIM where the data is processed and can then be resent to the PSDUS in a format where the data has been processed, the image enhanced or selectively processed (duplex scanning values or graphs). At the main UDIM, where the data processing takes place there is a sending and receiving unit that works at the probe interface. Data is formatted to be acceptable and duplicate the process of data transmission as if there were the standard transducer probe sending the data back after the sonic penetration.

Duplex imaging and statistical analysis are only several of the higher level processing functions that these machines perform. The smaller units for imaging process only imaging data. The data is the same when digitized as the processed data from the larger UDIM which with the current technology of streaming video and airports (wireless data transmission) can be processed by the larger unit and sent for viewing by the smaller PSDUS unit. This enables a technician to actually take the readings with anatomical landmark knowledge and see the probe location. Slight rotations or

movements can either be accomplished by commanding a motorized (mechanical) transducer probe or instructing the movement since at the main UDIM the image seen by the technician can be viewed in real time.

Assessment of the data received at the main UDIM can begin and analysis (duplex scanning or other important data) can be finished at the main UDIM. A physician or higher level RVP technician working with the portable unit may require the analysis at the patient's bedside. The processed data is requested and sent down to the portable from the main UDIM after processing. Even simple processing functions like increased resolution now give the satellite hand-held unit a higher quality visual at the limits of the monitor quality because the channel inputs received from the hand-held unit have more refinement in their signal processing in the main UDIM.

Advantages

From the description above, a number of advantages of the present invention become evident:

- (a) The portable satellite hand carried ultrasonic imaging machine has the ability of processing the ultrasonic image data by digitally compressing it and sending it to the main UDIM for processing and then returning the processed data in the requested format (example: a duplex scanned image with a statistical average of ten flow measurements) which will give complex information which includes but is not limited to duplex scanning of images or statistical data processing related to the ultrasonic image information.
- (b) since digitized information can be sent between the units, the possibility of a mechanized transducer probe that could be placed over a general anatomical landmark, would allow a technician at the main UDIM to control the placement of the transducer probe at a location away from the main UDIM since the technician is able to view the information sent from the portable hand carried satellite ultrasonic imaging system. Exact placement from server motor movement of the transducer probe through this command function would require less technical expertise on the part of the technician at the bedside.
- (c) the use of a satellite device means that travel time to wheel the heavy main UDIM to the bedside is reduced. More rapid response time and the ability to take the image from the portable unit and send the data (image) for storage and eventual processing makes physician's time more flexible and results in both time and cost savings.
- (d) the liability to the patient (maybe not receiving the scan) and the main UDIM (movement of a large machine translates to wear and breakage) is reduced since neither the patient nor the UDIM need be moved.
- (e) the application specialists training can be reduced.
- (f) the treatment time can be minimized due to the simplified portable machine operation
- (g) now complex data analysis and not merely the interpretation of a grayscale image are available at any location that a hand carried portable unit can travel.
- (h) the patient is more content and less anxious because of the improved convenience.
- (i) the diagnosis is completed more rapidly and at less expense with a greater and more complex analysis which would reduce patient mortality and long term treatment of venous and arterial illnesses.
- (j) With the reduction of the educational requirements of the ultrasound technician and the expediency of the setup time costs to the hospitals and the patients are reduced.
- (k) Features such as high definition imaging, color pulsed doppler, greater than 256 gray shade two dimensional

imaging, color values from a 24 bit palette and digital coherent processing (phase and amplitude information to optimize resolution and frame rate).

- (l) Accurate and complex venous screening for Deep Vein Thrombosis (venous thromboembolism) and the resultant life threatening pulmonary embolism (PE) can now be performed on more patients at minimal cost and time with lifesaving results whereas now this type of screening is avoided entirely for logistical and financial reasons.

Operation

FIGS. 1 and 2 show the 18 hand carried portable ultrasonic imaging machine with its 26 connection which because of electrical signals is not capable of being wireless. The 28 sending/receiving port is responsible for wireless or hard T3 communications wiring transmission or reception of the data signals to and from the main UDIM and in the 30 satellite sending/receiving unit at the main UDIM 10. The satellite sending/receiving unit 30 is called a 12 base station because its power of transmission must be higher than the sending port 28 on the 18 hand carried portable ultrasonic imaging machine.

To operate, the technician with a transducer probe connected to the satellite unit generates an image of blood moving in a vein. The image is clear and in the correct viewing format to gather some complex diagnostic data such as a spectral doppler image. An interval of viewed time of the vein is then sent as digitized information to the main UDIM which is manned by a technician which takes the image data and processes it into a spectral doppler image (a duplex scan), the technician at the bedside commands that this processed data be sent to the bedside portable satellite ultrasonic imaging machine. The image then is transmitted and at bedside with a strictly imaging device can now view more diagnostic information for assessment and make a decision. This information is also viewable by the physician which could be stationed at the main UDIM which prevents his/her movement to the bedside or the information could be sent to a network where it could be accessed or downloaded at the physicians office for example. This has numerous advantages which are noted above.

CONCLUSION, RAMIFICATIONS, AND SCOPE

Accordingly, the reader will see the portable hand carried satellite diagnostic ultrasound system for use in conjunction

with a standard 128 or more channel main ultrasound system with complex data processing features such as duplex scanning technology is an important invention for the health industry as is will bring a major diagnostic tool to more bedsides because of its portability and reduce the cost of treatment as the main ultrasonic machine will not have to be transported to the bedside and minimal training will be needed to scan with the portable unit allowing many more people the use of this diagnostic tool in the hospital and in the field.

We claim:

1. In an ultrasound imaging system for generating image data at a first location in response to scanning of a subject under study, an improved apparatus for processing the transmitted data and transmitting the processed data comprising in combination of:

- a computer connected to the portable satellite hand carried ultrasonic imaging machine
- a network interface connected to the portable satellite hand carried ultrasonic imaging machine and computer that includes an air port function (network transmit module and network receive module) for the transmission and reception of data to and from the main ultrasound diagnostic imaging machine (UDIM)
- a network interface connected to the main ultrasound diagnostic imaging machine (UDIM) that includes an air port function (network transmit module and network receive module) for the transmission and reception of data to and from the portable satellite hand carried ultrasonic imaging machine
- an asynchronous network for transmitting the received data via an internet protocol, whereby image data generated by the hand carried portable ultrasound imaging system may be transmitted with or without wires to a network before storage or to main UDIM where the image data may be processed or refined and then transmitted back to the portable satellite hand carried ultrasonic imaging machine or to a network before storage.

* * * * *

专利名称(译)	便携式手提卫星诊断超声系统，用于一般和心脏成像		
公开(公告)号	US6478740	公开(公告)日	2002-11-12
申请号	US09/964722	申请日	2001-09-26
[标]申请(专利权)人(译)	SOUNEY SEAN ROEDER RICHARD W		
申请(专利权)人(译)	SOUNEY SEAN ROEDER RICHARD W.		
当前申请(专利权)人(译)	SOUNEY, SEAN		
[标]发明人	SOUNEY SEAN ROEDER RICHARD W		
发明人	SOUNEY, SEAN ROEDER, RICHARD W.		
IPC分类号	A61B8/00 A61B5/00		
CPC分类号	A61B8/00 A61B5/0022 A61B8/0883 A61B8/0891 A61B5/7232 G16H40/67		
助理审查员(译)	帕特尔MAULIN		
优先权	60/235481 2000-09-26 US		
其他公开文献	US20020040186A1		
外部链接	Espacenet USPTO		

摘要(译)

超声成像系统18，用于在第一位置16产生图像数据，该第一位置16将所述数据发送到主超声诊断成像机10，以处理或观察图像数据。可以将数据处理到主机10的能力，然后以主机10的格式能力（双面扫描，彩色增强图像等）格式化，其中数字数据可以通过硬线或无线传输发送。到用于观看的网络（图像或处理的数据）或便携式手持卫星超声成像机。

