



US010624610B2

(12) **United States Patent**
Yamakoshi

(10) **Patent No.:** **US 10,624,610 B2**
(45) **Date of Patent:** **Apr. 21, 2020**

(54) **ULTRASONIC IMAGING SYSTEM**

(71) Applicant: **National University Corporation
Gunma University, Maebashi-shi (JP)**

(72) Inventor: **Yoshiki Yamakoshi, Maebashi (JP)**

(73) Assignee: **National University Corporation
Gunma University, Maebashi-shi (JP)**

(*) Notice: Subject to any disclaimer, the term of this patent is extended or adjusted under 35 U.S.C. 154(b) by 458 days.

(21) Appl. No.: **15/301,283**

(22) PCT Filed: **Mar. 25, 2015**

(86) PCT No.: **PCT/JP2015/059207**

§ 371 (c)(1),

(2) Date: **Sep. 30, 2016**

(87) PCT Pub. No.: **WO2015/151972**

PCT Pub. Date: **Aug. 10, 2015**

(65) **Prior Publication Data**

US 2017/0014104 A1 Jan. 19, 2017

(30) **Foreign Application Priority Data**

Apr. 2, 2014 (JP) 2014-076527

(51) **Int. Cl.**

A61B 8/08 (2006.01)

A61B 8/14 (2006.01)

(Continued)

(52) **U.S. Cl.**

CPC **A61B 8/485** (2013.01); **A61B 8/06** (2013.01); **A61B 8/0833** (2013.01); **A61B 8/14** (2013.01);

(Continued)

(58) **Field of Classification Search**

CPC A61B 8/485; A61B 8/14; A61B 8/5223; A61B 8/488

See application file for complete search history.

(56) **References Cited**

U.S. PATENT DOCUMENTS

5,919,139 A 7/1999 Lin
7,444,875 B1 * 11/2008 Wu A61B 8/08
73/602

(Continued)

FOREIGN PATENT DOCUMENTS

JP 2008-154012 A 7/2008
JP 2012-249776 A 12/2012

(Continued)

OTHER PUBLICATIONS

Wu et al. "Sonoelastographic imaging of interference patterns for estimation of the shear velocity of homogeneous biomaterials" Phys. Med. Biol. 49 (2004) 911-922.*

(Continued)

Primary Examiner — Bill Thomson

Assistant Examiner — Aminah Asghar

(74) *Attorney, Agent, or Firm* — Oblon, McClelland, Maier & Neustadt, L.L.P.

(57) **ABSTRACT**

An existing ultrasonic diagnostic device is used to obtain a color flow image of a target object whose stiffness is to be measured. At this time, a vibration exciter applies a micro vibration with a frequency of $n/4$ (n represents an odd number equal to or larger than 1) to the target object with respect to a burst frequency of an ultrasonic pulse to generate a shear elastic wave. As a result, a striped pattern corresponding to the stiffness of the target object caused by the shear elastic wave appears on a display of the ultrasonic diagnostic device as a shear elastic wave detection image.

5 Claims, 9 Drawing Sheets

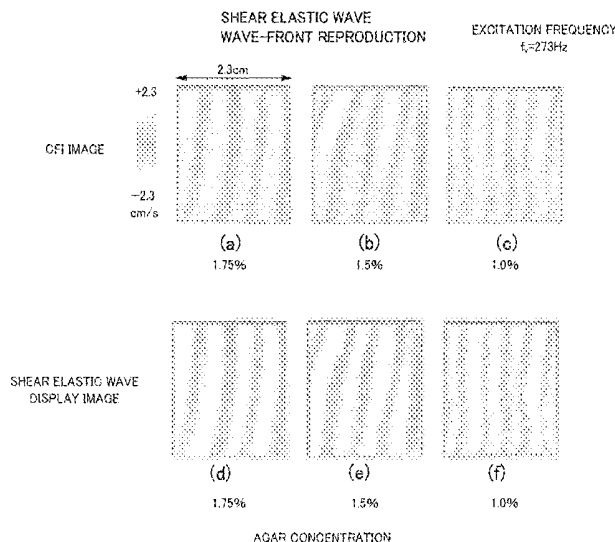

- (51) **Int. Cl.**
A61B 8/00 (2006.01)
A61B 8/06 (2006.01)
- (52) **U.S. Cl.**
 CPC *A61B 8/461* (2013.01); *A61B 8/488*
 (2013.01); *A61B 8/5223* (2013.01)

FOREIGN PATENT DOCUMENTS

JP	2014-42823 A	3/2014
WO	WO 2008/141220 A1	11/2008
WO	WO 2012/158877 A2	11/2012

(56) **References Cited**

U.S. PATENT DOCUMENTS

9,125,547 B2 *	9/2015	Xie	A61B 8/5223
9,986,973 B2 *	6/2018	Chen	A61B 8/48
2004/0040379 A1 *	3/2004	O'Donnell	A61B 5/0095
			73/627
2006/0052702 A1 *	3/2006	Matsumura	A61B 8/08
			600/443
2009/0056453 A1	3/2009	McAleavey	
2010/0185090 A1 *	7/2010	Suzuki	A61B 8/0858
			600/443
2012/0095323 A1 *	4/2012	Eskandari	A61B 5/0051
			600/411
2013/0165778 A1	6/2013	McAleavey	
2013/0245442 A1 *	9/2013	Hazard	G01S 7/52036
			600/438
2013/0261452 A1	10/2013	Tamura	
2013/0289402 A1 *	10/2013	Tabaru	A61B 8/08
			600/438
2014/0018679 A1 *	1/2014	Chen	A61B 8/085
			600/438
2014/0039317 A1	2/2014	Sato	
2014/0148697 A1	5/2014	Barry et al.	
2014/0180091 A1	6/2014	McAleavey	
2015/0272547 A1 *	10/2015	Freiburger	A61B 8/485
			600/438
2016/0051231 A1 *	2/2016	Kondo	A61B 8/485
			600/438
2017/0020486 A1 *	1/2017	Salcudean	A61B 8/485

OTHER PUBLICATIONS

Chen et al., "Shearwave Dispersion Ultrasound Vibrometry (SDUV) for Measuring Tissue Elasticity and Viscosity", IEEE Transactions on Ultrasonics, Ferroelectrics, and Frequency Control, vol. 56, No. 1, Jan. 2009 (Year: 2009).*

Bercoff et al., "Supersonic Shear Imaging: A New Technique for Soft Tissue Elasticity Mapping", IEEE Transactions on Ultrasonics, Ferroelectrics, and Frequency Control, vol. 51, No. 4, Apr. 2004 (Year: 2004).*

Raj Kumar Parajuli et al 2013 Jpn. J. Appl. Phys. 52 07H F22 (Year: 2013).*

N. Masuda, et al., "Low-Frequency Elastic Wave Imaging by Adaptive Combination of Fundamental and Tissue Harmonic Ultrasonic Waves," Japanese Journal of Applied Physics, vol. 42, Part 1, No. 5B, May 1, 2003, 5 pages (with English abstract).

International Search Report dated Jun. 23, 2015 in PCT/JP2015/059207 Filed Mar. 25, 2015.

Extended European Search Report dated Dec. 22, 2017 in Patent Application No. 15773342.9, citing documents AC-AF, AO, AP and AX therein, 8 pages.

Yoshiki Yamakoshi, et al., "Ultrasonic Imaging of Internal Vibration of Soft Tissue under Forced Vibration" IEEE, Transactions on Ultrasonics, Ferroelectrics and Frequency Control, vol. 37, No. 2, XP011438071, Mar. 1, 1990, pp. 45-53.

* cited by examiner

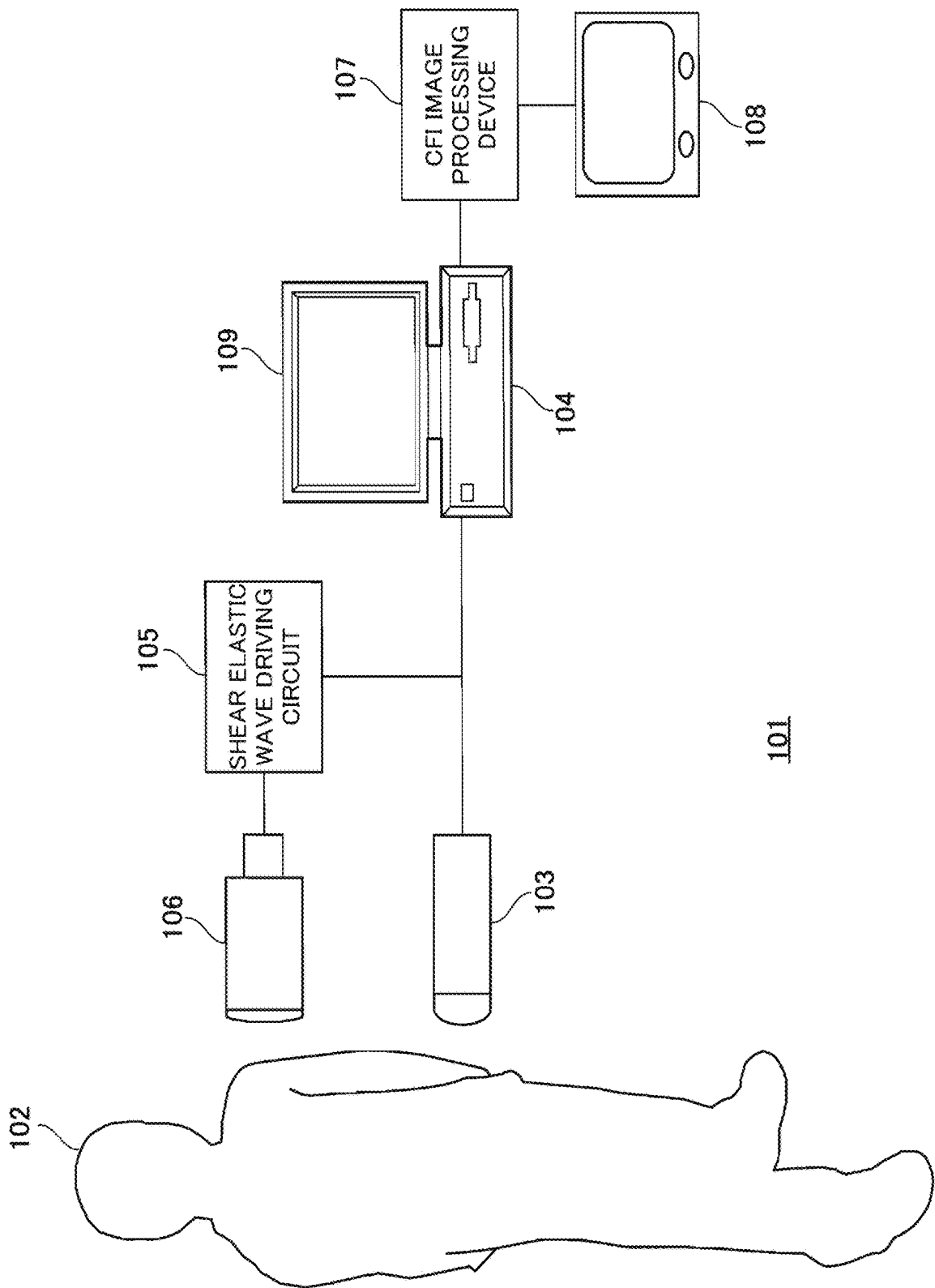

FIG. 1

FIG. 2

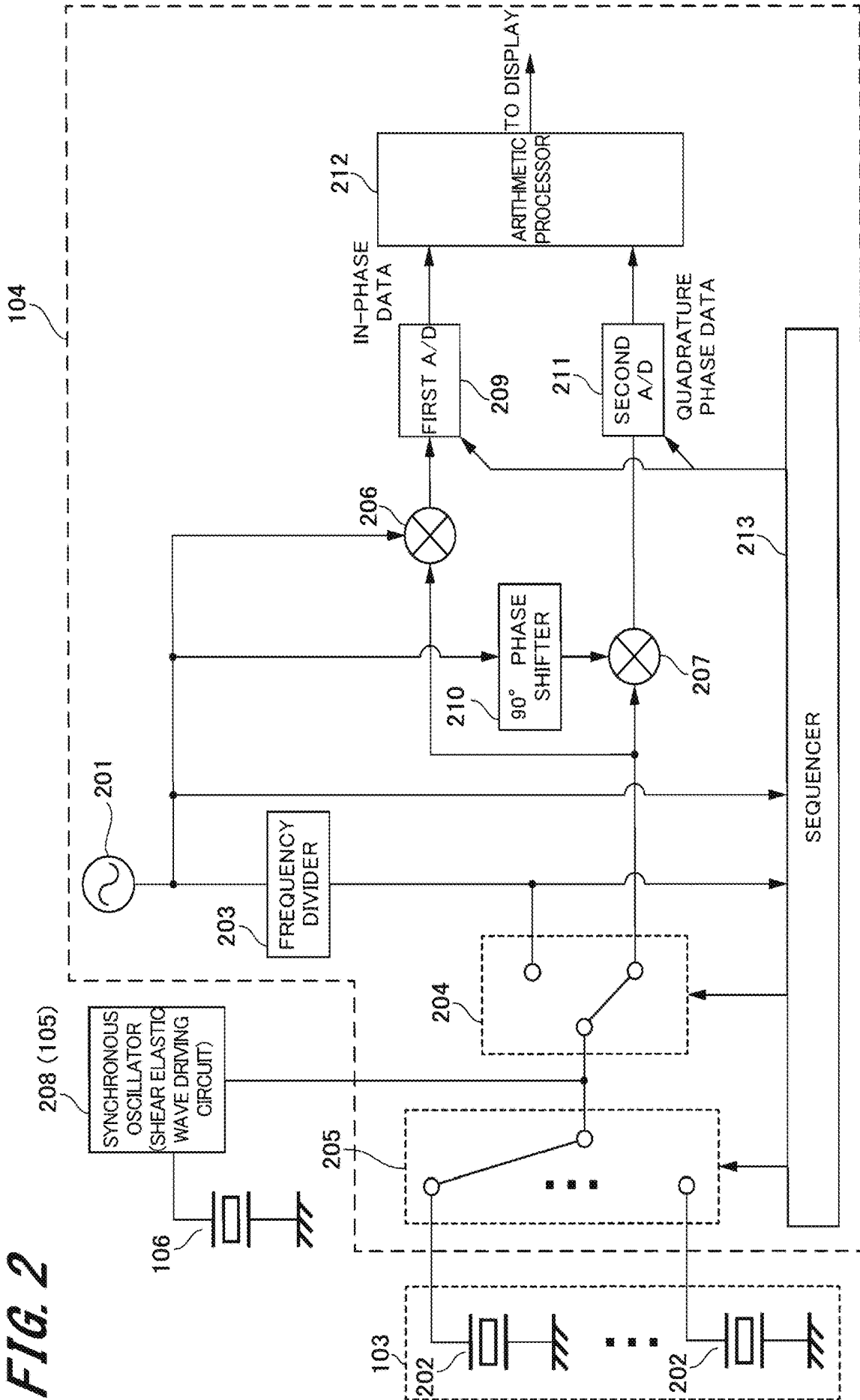

FIG. 3

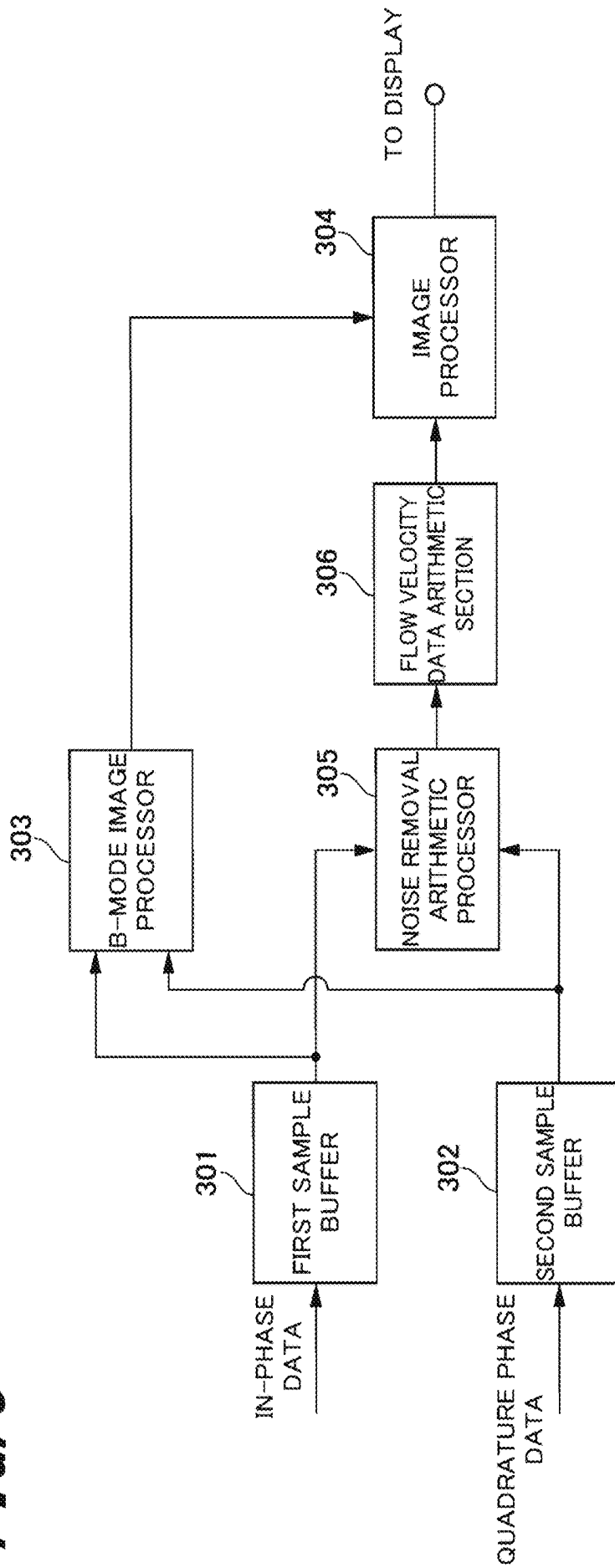

FIG. 4

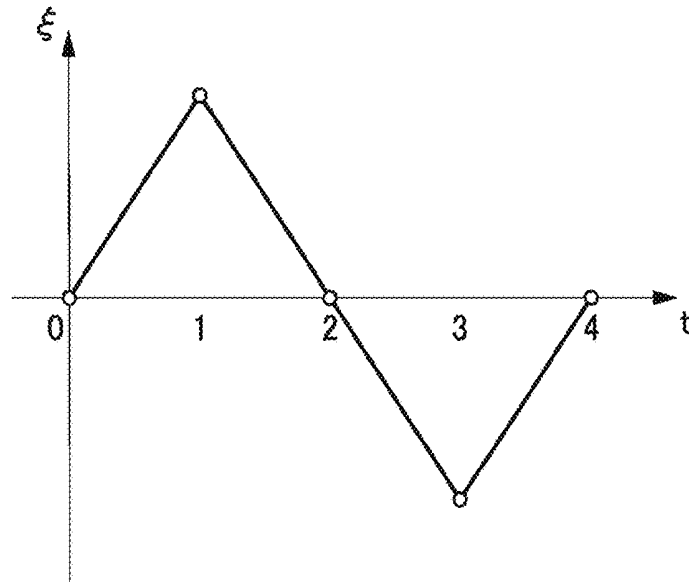

FIG. 5A

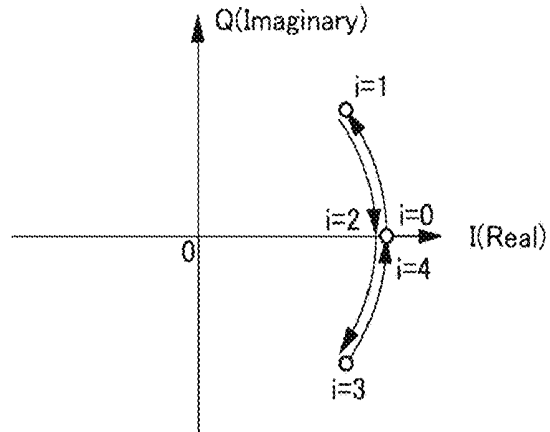

FIG. 5B

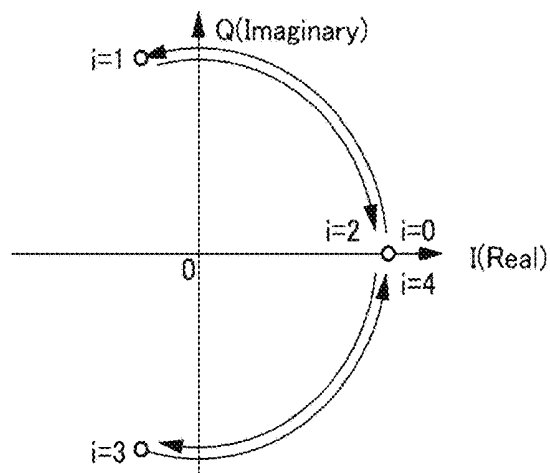

FIG. 6A

BASIC OPERATOR 1

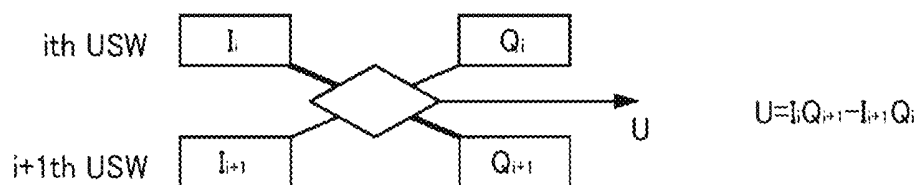

FIG. 6B

BASIC OPERATOR 2

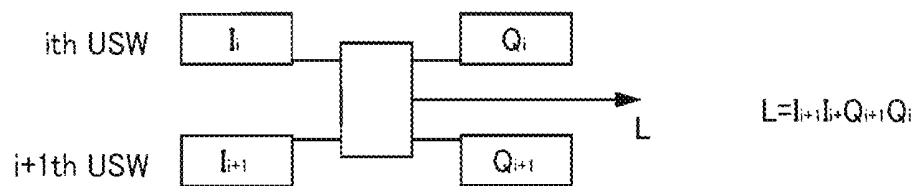

FIG. 7A

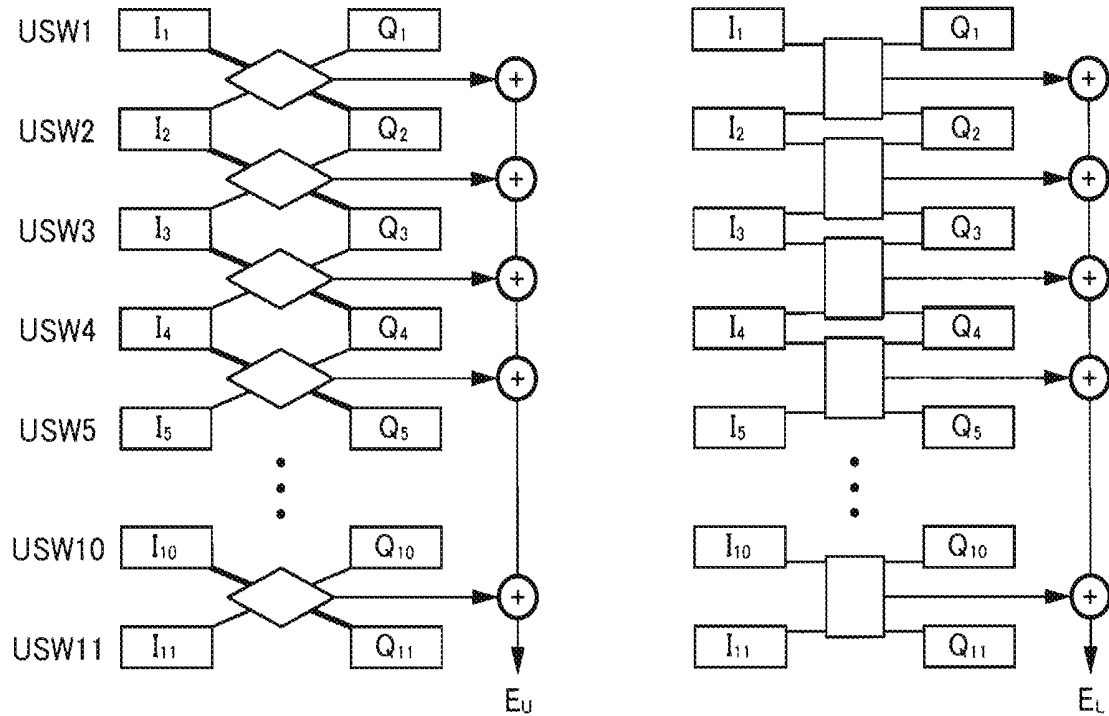

FIG. 7B

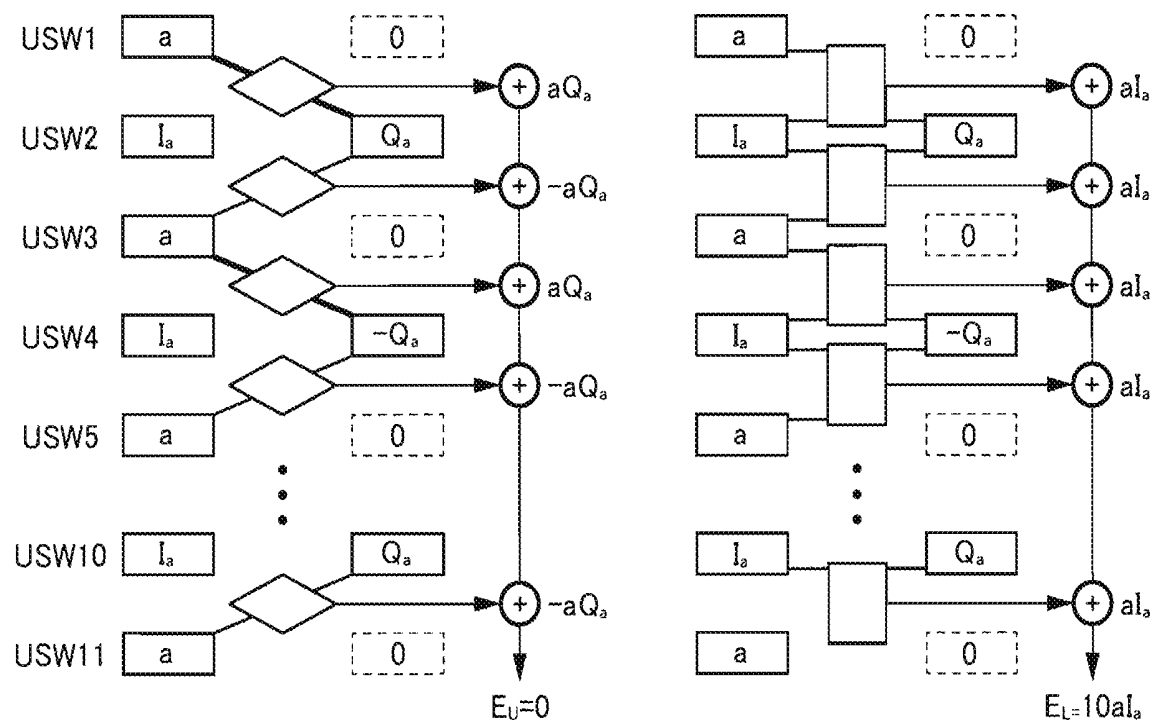
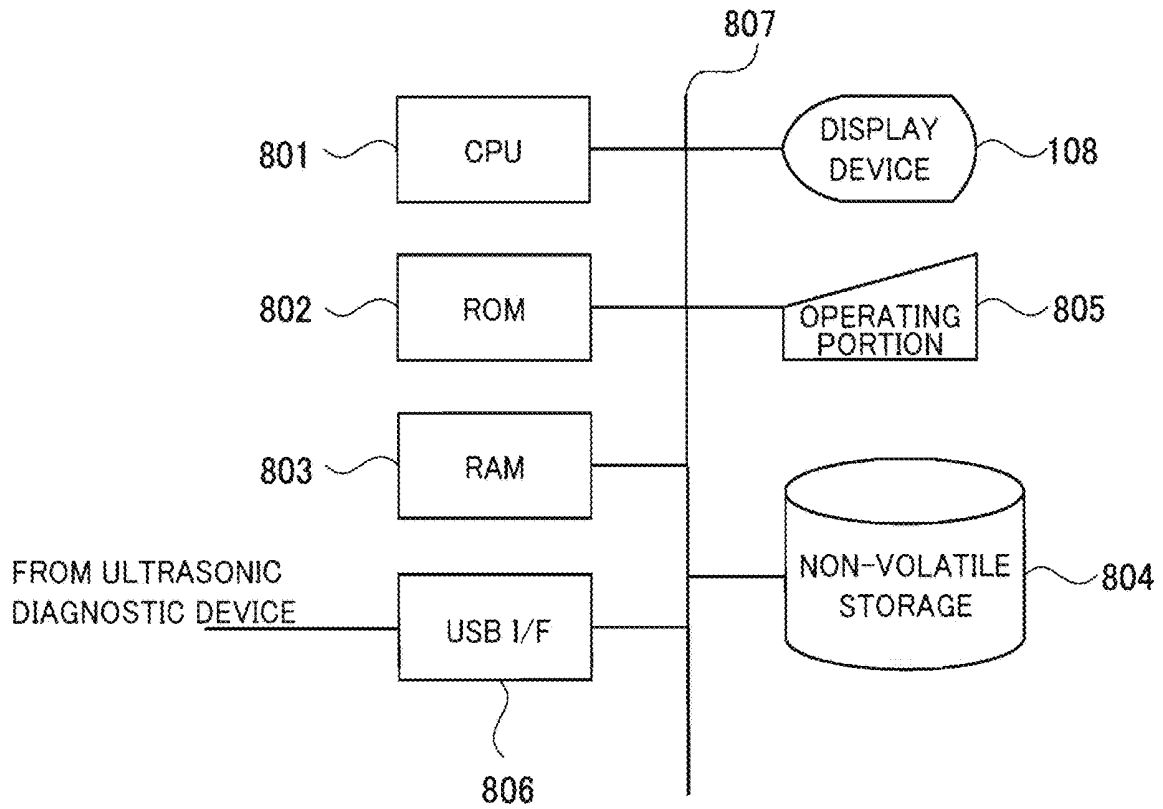
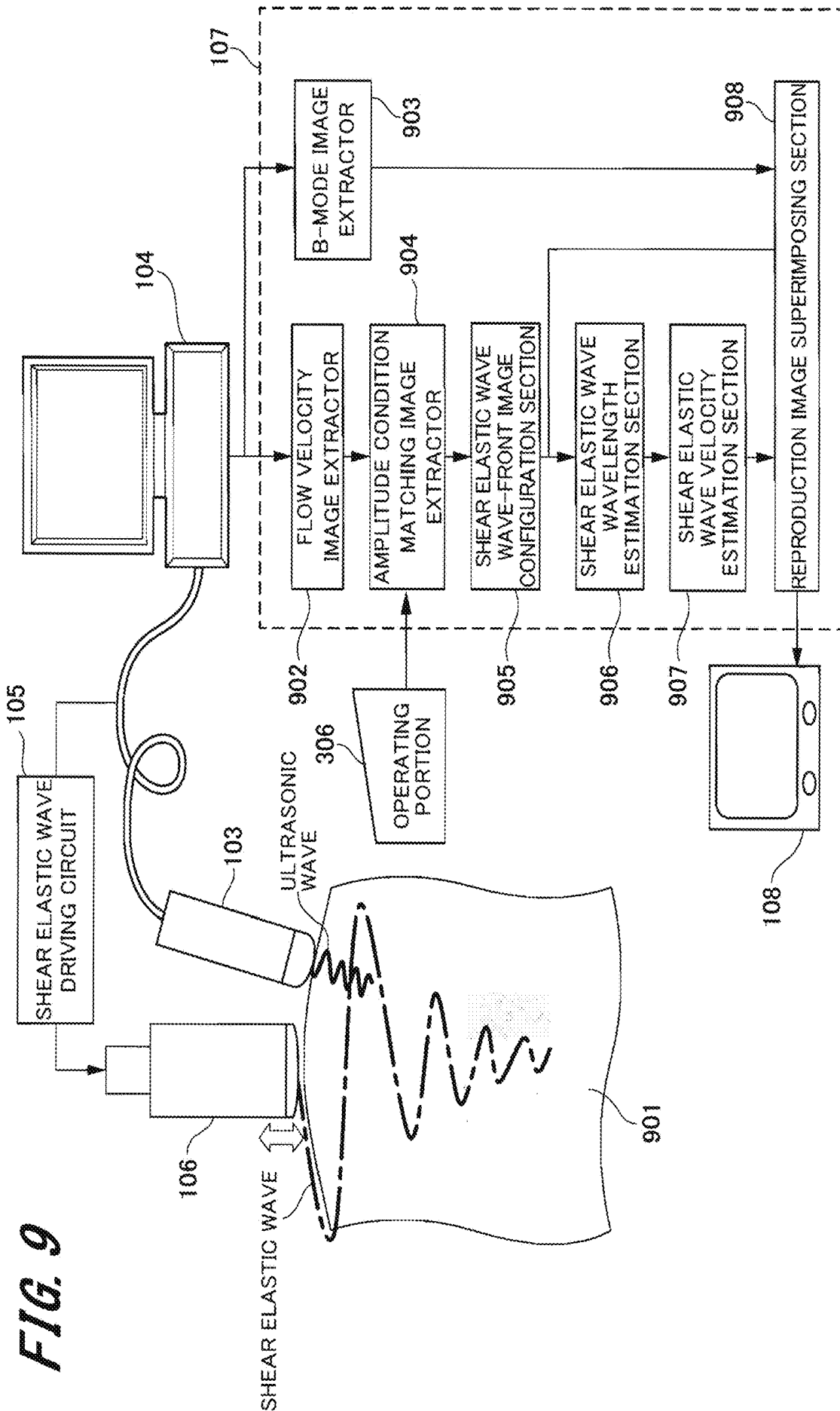
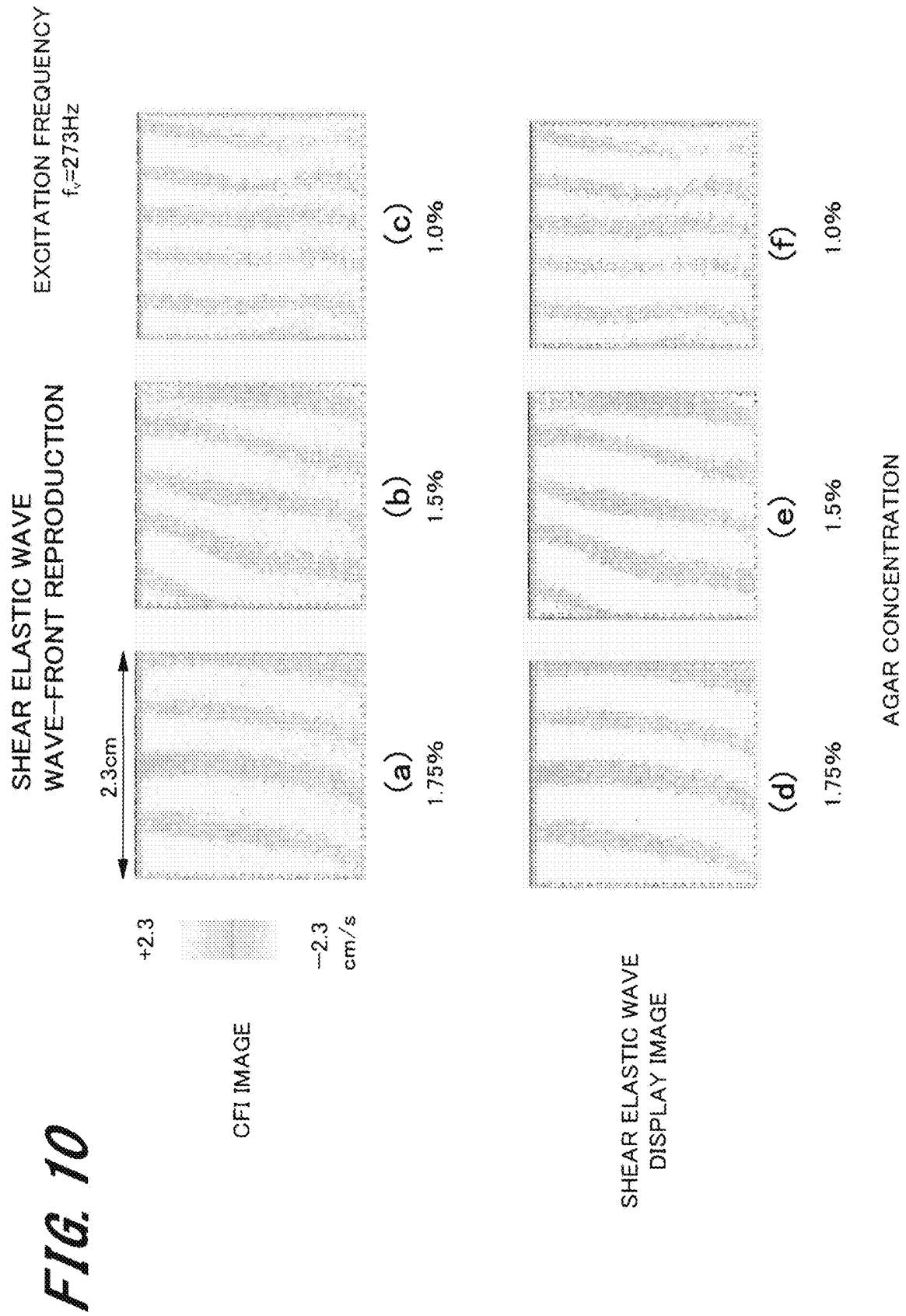

FIG. 8







ULTRASONIC IMAGING SYSTEM

TECHNICAL FIELD

The present invention relates to an ultrasonic imaging system mainly for medical application, the ultrasonic imaging system being adapted to use an ultrasonic wave to form a cross-sectional image of a subject in a non-invasive manner.

BACKGROUND ART

An ultrasonic diagnostic device emits an ultrasonic wave generated by an ultrasonic transducer built-in an ultrasonic probe toward a subject, and receives, with the ultrasonic transducer, a reflected signal generated due to the difference in acoustic impedance of the tissue of the subject. Further, the reflected signal is subjected to an arithmetic processing, such as Fourier transform, to form an image to be displayed on a display. Since such ultrasonic diagnostic device can easily observe a two-dimensional image of the tissue of the subject in real time by performing a simple and non-invasive operation of contacting the ultrasonic probe onto the surface of the subject, it is widely used for performing function test of a heart or the like, and shape diagnostics of various organs. Particularly, since almost no radiation injury is caused to the subject, such diagnostic imaging method is essential for performing fetus growth diagnostic.

The PLT 1 and NPL 1 listed below are prior arts close to the technical field of the present invention.

PLT 1 discloses technical contents of a method and system for imaging a three-dimensional ultrasonic scattering medium in a subject volume.

NPL 1 discloses technical contents of an exciting imaging method for estimating the propagation velocity of the phase change of a low-frequency vibration applied from outside.

CITATION LIST

Patent Literature

PTL 1: Japanese Unexamined Patent Application Publication No. 2008-154012

Non Patent Literature

NPL 1: "Elastic wave imaging by adaptive combination of fundamental and tissue harmonic ultrasonic waves" by Masuda Nobuyuki, Tsujita Takehiro, Ebuchi Tomoaki, Yamakoshi Yoshiki, published in a symposium on ultrasonic electronics (23), accessible at: <http://ci.nii.ac.jp/naid/110007464507> (searched on Apr. 23, 2013)

SUMMARY OF INVENTION

Technical Problem

Evaluation of stiffness of body tissue is attracting increasing attention, particularly in diagnostic areas of liver, mammary gland, prostate gland and the like where the stiffness of the tissue has close relationship with diseases. Further, in the orthopedic surgery, if function of skeletal muscle can be evaluated from the stiffness, it will be helpful for diagnosing diseases related to skeletal muscle, such as muscular dystrophy, and helpful for performing intraoperative evaluation for tendon repair treatment.

In a frequency of an ultrasonic wave, compressional elastic wave is predominant; therefore, almost all conventional ultrasonic diagnostic devices do not have a function to measure the stiffness of body tissue. The compressional elastic wave is a wave whose vibration direction is parallel to the transmission direction of the vibration in the medium. The compressional elastic wave is a wave accompanied by volume change of the medium, and is equivalent to a P-wave associated with vertical vibration, if taking earthquake as an analogy. Since the transmission speed of the compressional elastic wave almost does not depend on the stiffness of the medium, it is extremely difficult to detect the stiffness of the medium with an ultrasonic diagnostic device that uses an ultrasonic wave as it is.

In techniques for measuring the stiffness of the body tissue, there are two types of techniques known as below.

The first technique is called "elastography" that is a method in which the portion where the stiffness is to be measured of the subject is pressed by a hand or the like, and deformation of the tissue caused by the pressure is measured from an ultrasonic image.

The second technique is a method in which the portion where the stiffness is to be measured is irradiated by a high intensity ultrasonic pulse, and an acoustic radiation pressure caused by the pulse excites a shear elastic wave in the body tissue. Further, Doppler frequency shift signal of the ultrasonic wave caused by the shear elastic wave generated in the body tissue is detected to measure the stiffness of the body tissue. Incidentally, in the description of the present invention, such method is called "acoustic radiation pressure method". The shear elastic wave is also called "shear wave", and is a wave whose vibration direction is perpendicular to the propagation direction of the vibration in the medium. The shear elastic wave is a wave not accompanied by volume change of the medium, and is equivalent to an S-wave associated with lateral vibration, if taking earthquake as an analogy. The propagation speed of the shear elastic wave largely depends on the stiffness of the medium.

The advantage of the elastography method is that the measurement principle thereof is simple, and the disadvantage is that it has poor quantitiveness and that the measurement accuracy depends on the skill of the operator.

The advantage of the acoustic radiation pressure method is that it is possible to perform quantitative measurement; however, since heat will be generated in the body tissue due to the radiation of the high intensity ultrasonic wave, there is a safety concern for human body.

In view of the aforesaid problems, an object of the present invention is to provide an ultrasonic imaging system capable of imaging the stiffness of the object-to-be-measured easily and safely simply by adding an extremely simple device to a conventional ultrasonic diagnostic device.

Solution to Problem

To solve the aforesaid problems, an ultrasonic imaging system according to an aspect of the present invention comprises an ultrasonic image forming device capable of outputting a color flow image which renders a fluid existing within an object-to-be-measured by: outputting an ultrasonic pulse for measuring the inside structure of the object-to-be-measured in a non-invasive manner, emitting the ultrasonic pulse from an ultrasonic probe for receiving the ultrasonic pulse, and receiving the ultrasonic pulse; and a shear elastic

wave generator that applies a vibration with a predetermined frequency to the object-to-be-measured.

Advantageous Effects of Invention

According to the present invention, it is possible to image the stiffness of the object-to-be-measured easily and safely simply by adding an extremely simple device to a conventional ultrasonic diagnostic device.

Other problems, configurations and effects than those described above will be known from the description of the following embodiment.

BRIEF DESCRIPTION OF DRAWINGS

FIG. 1 is a block diagram showing the entire configuration of an ultrasonic imaging system according to an embodiment of the present invention;

FIG. 2 is a functional block diagram of the ultrasonic diagnostic device;

FIG. 3 is a functional block diagram of an arithmetic processor;

FIG. 4 is a graph showing a relationship between the cycle and displacement amplitude of a displacement vibration of a tissue caused by the propagation of a shear elastic wave;

FIGS. 5A and 5B are vector diagrams showing the relationship between amplitudes of an output signal of a quadrature detector for each i -th sample value;

FIGS. 6A and 6B are model diagrams respectively showing a first basic operator and a second basic operator;

FIGS. 7A and 7B are model diagrams of a flow velocity derivation algorithm of the ultrasonic diagnostic device in a case where ultrasonic pulse transmission/reception numbers $N=11$;

FIG. 8 is a block diagram showing a hardware configuration of a CFI image processing device;

FIG. 9 is a functional block diagram of the CFI image processing device; and

FIG. 10 is a view showing examples of a shear elastic wave detection image displayed on the ultrasonic diagnostic device and a shear elastic wave display image displayed on a display device of the ultrasonic imaging system of the present embodiment.

DESCRIPTION OF EMBODIMENTS

In a vibration, the ratio of compressional elastic wave to shear elastic wave varies according to the frequency of the vibration. The lower the frequency is, the more dominant the shear elastic wave will become.

Generally, the propagation velocity of the shear elastic wave is proportional to the square root of the stiffness of the medium. Therefore, it becomes possible to measure the stiffness of an object-to-be-measured if it is possible to apply a shear elastic wave to the object-to-be-measured and detect the propagation velocity of the shear elastic wave.

In an ultrasonic imaging system according to an embodiment of the present invention, a color flow image display function (which is adapted to detect existence and velocity of a fluid within a tissue) provided by an ultrasonic diagnostic device is used to display the wave front of the shear elastic wave as an image.

[Entire Configuration of Ultrasonic Imaging System 101]

FIG. 1 is a block diagram showing the entire configuration of an ultrasonic imaging system 101 according to the embodiment of the present invention.

The ultrasonic imaging system 101 is configured by adding a shear elastic wave driving circuit 105, a vibration exciter 106 (which is excited by the shear elastic wave driving circuit 105), a CFI image processing device 107, and a display device 108 to an ultrasonic diagnostic device 104 (i.e., an ultrasonic image forming device) which is provided with an ultrasonic probe 103 for emitting ultrasonic pulse to a subject 102. Incidentally, the CFI image processing device 107 and display device 108 may also be omitted, so that only the shear elastic wave driving circuit 105 and vibration exciter 106 are added to the ultrasonic diagnostic device 104. In such a case, an image including a characteristic striped pattern caused by the shear elastic wave is displayed on a display 109 of the ultrasonic diagnostic device 104, though the image is mixed with noises. The stiffness of the body tissue of the subject 102 can be estimated based on the intervals of the striped pattern. The image of the striped pattern caused by the shear elastic wave and displayed on the display 109 of the ultrasonic diagnostic device 104 is hereinafter referred to as a “shear elastic wave detection image”. An image obtained by processing the data of the shear elastic wave detection image with the CFI image processing device 107 and displaying the result as an image on the display device 108 is hereinafter referred to as a “shear elastic wave display image”.

The ultrasonic diagnostic device 104 has a function of outputting a “B-mode image” (i.e., a function of outputting an ultrasonic pulse from the ultrasonic probe 103, and shows the existence of the inside of the body tissue as a black-and-white image). In addition to the function of outputting the “B-mode image”, the ultrasonic diagnostic device 104 also has a function of outputting a “color flow image”, which is also called “color flow mapping” (i.e., a function of detecting Doppler effect generated by the bloodstream flowing in the blood vessels, dividing the bloodstream colors, and displaying the results over the B-mode image). The ultrasonic pulse is a burst wave obtained by outputting a high frequency ultrasonic wave with a frequency of about 1 MHz or higher at a cycle of, for example, 365 Hz. Hereinafter, a frequency corresponding to the cycle of the ultrasonic pulse is referred to as a “burst frequency”.

The vibration exciter 106 generates a low frequency micro vibration under a drive voltage outputted by the shear elastic wave driving circuit 105. The content of the vibration exciter 106 is a piezoelectric element, and the details of the vibration exciter 106 will be discussed later with reference to FIG. 2. Obviously, the vibration exciter may also be an electromagnetically driven vibration exciter similar to a widely known speaker.

The shear elastic wave driving circuit 105 generates a shear elastic wave with a frequency satisfying Equation (1) and an amplitude satisfying Equation (2), with respect to the burst frequency of the ultrasonic pulse supplied from the ultrasonic diagnostic device 104 to the ultrasonic probe 103.

[Mathematical Expression 1]

$$f_b = \frac{1}{2} \left(m + \frac{1}{2} \right) f_e \quad (1)$$

where:

m represents an integer equal to or greater than 0

f_e represents burst frequency

$$\frac{\lambda}{8} \leq \xi_0 \leq \frac{3\lambda}{8} \quad (2)$$

where:

λ represents wavelength of ultrasonic wave

ξ represents vibration amplitude of shear elastic wave

For example, in the case where the burst frequency is 365 Hz, the frequency of the shear elastic wave will be:

91.25 Hz, when $m=0$;

273.75 Hz, when $m=1$;

456.25 Hz, when $m=2$;

638.75 Hz, when $m=3$.

In other words, the frequency of the shear elastic wave is obtained by multiplying the burst frequency by a fraction: $\frac{1}{4}, \frac{3}{4}, \frac{5}{4}, \frac{7}{4} \dots$, where the denominator of the fraction is 4, and the numerator of the fraction is an odd number starting from 1.

For example, in the case where the center frequency of the ultrasonic pulse is 5 MHz, the amplitude of the shear elastic wave depends on the propagation velocity of the medium propagated by the shear elastic wave, and excellent shear elastic wave detection image and shear elastic wave display image can be obtained when the vibration exciter **106** is vibrated at an amplitude of 100 microns, for example.

When causing the vibration exciter **106** to generate a shear elastic wave having a frequency satisfying Equation (1) and abutting the vibration exciter **106** to a measurement part of the subject **102** (wherein the measurement part is near to a portion brought into contact with the ultrasonic probe **103**), a striped pattern depending on the stiffness of the body tissue appears on the color flow image (which shows blood-stream) displayed on the display **109** of the ultrasonic diagnostic device **104**. The interval of the striped pattern corresponds to the wavelength of the shear elastic wave within the body tissue. Since the propagation velocity of the shear elastic wave is generally proportional to the square root of the stiffness of the medium, the stiffness of the body tissue can be estimated by measuring the intervals of the striped pattern.

In order to display an excellent shear elastic wave detection image, the phase difference of the shear elastic wave outputted from the shear elastic wave driving circuit **105** with respect to the edges of the ultrasonic pulse may be maintained within a desired error range. FIGS. **1** and **2** are made based on an assumption that the shear elastic wave outputted from the shear elastic wave driving circuit **105** is synchronized with edges of the ultrasonic pulse; however, the shear elastic wave and the edges of the ultrasonic pulse do not have to be synchronized with each other if the burst frequency of the ultrasonic pulse and the frequency of the shear elastic wave have sufficient accuracy.

FIG. **2** is a functional block diagram of the ultrasonic diagnostic device **104**.

The oscillator **201** outputs a drive signal of the center frequency of the ultrasonic probe **103** coming from a plurality of ultrasonic transducers **202** provided within the ultrasonic probe **103**. The center frequency of the ultrasonic wave is 5 MHz, for example. The entity of each ultrasonic transducer **202** is a piezoelectric element. The piezoelectric element deforms when voltage is applied thereto, and the piezoelectric element generates a voltage when being deformed. The signal outputted from the oscillator **201** is supplied to a frequency divider **203**. The frequency divider **203** generates an ultrasonic pulse with a predetermined burst frequency based on the drive signal. The center frequency of

the ultrasonic pulse is 365 Hz, for example. The ultrasonic pulse outputted from the frequency divider **203** is selectively supplied to the plurality of ultrasonic transducers **202** through a first multiplexer **204** and a second multiplexer **205**.

The first multiplexer **204** is adapted to switch transmission and reception of the ultrasonic probe **103**. When performing transmission, the first multiplexer **204** connects the ultrasonic probe **103** to the frequency divider **203**; while when performing reception, the first multiplexer **204** connects the ultrasonic probe **103** to a first multiplier **206** and a second multiplier **207**.

The second multiplexer **205** is adapted to select one of the plurality of ultrasonic transducers **202** housed in the casing of the ultrasonic probe **103**.

On the other hand, the ultrasonic pulse is also supplied to a synchronous oscillator **208** through the first multiplexer **204**. The synchronous oscillator **208** is the entity of the shear elastic wave driving circuit **105**. The synchronous oscillator **208** outputs a drive voltage with a frequency satisfying the aforesaid Equation (1) with respect to the burst frequency of the ultrasonic pulse. The drive voltage drives the piezoelectric element built in the vibration exciter **106**.

Incidentally, a high voltage required to drive the piezoelectric element used for the ultrasonic probe **103** and the vibration exciter **106**; due to limited space of the drawings, description about the high voltage generating means is omitted in FIG. **2**.

The reception-side terminal of the first multiplexer **204** is connected to the first multiplier **206** and second multiplier **207** which configure a quadrature detector.

The first multiplier **206** multiplies a reception signal outputted from the ultrasonic probe **103** by the drive signal. The signal outputted from the first multiplier **206** is supplied to a first A/D converter **209** (which is referred to as "first A/D" in FIG. **2**) where the signal is subjected to an A/D conversion. The output data of the first A/D converter **209** is "in-phase data" corresponding to a real number component. The in-phase data is supplied to an arithmetic processor **212**.

The second multiplier **207** multiplies a reception signal outputted from the ultrasonic probe **103** by a drive signal whose phase has been delayed by 90° by a phase shifter **210**. The signal outputted from the second multiplier **207** is supplied to a second A/D converter **211** (which is referred to as "second A/D" in FIG. **2**) where the signal is subjected to an A/D conversion. The output data of the second A/D converter **211** is "quadrature phase data" corresponding to an imaginary component. The quadrature phase data is supplied to the arithmetic processor **212**.

FIG. **3** is a functional block diagram of the arithmetic processor **212**.

The in-phase data is once stored in a first sample buffer **301**, which is configured by a widely known RAM.

Similarly, the quadrature phase data is also once stored in a second sample buffer **302**, which is configured by a widely known RAM.

The in-phase data stored in the first sample buffer **301** and the quadrature phase data stored in the second sample buffer **302** are subjected to an arithmetic processing for generating a B-mode image performed by a B-mode image processor **303**, wherein the in-phase data and the quadrature phase data each have a predetermined duration. The arithmetic processing is a processing for generating a black-and-white image mainly by means of FFT (fast Fourier transform). The B-mode image data generated by the B-mode image processor **303** is supplied to an image processor **304**.

On the other hand, the in-phase data stored in the first sample buffer 301 and the quadrature phase data stored in the second sample buffer 302, each having a predetermined duration, are subjected to a noise removing processing performed by a noise removal arithmetic processor 305, and a signal component associated with Doppler effect of blood-stream is extracted. The signal component associated with Doppler effect is converted into color flow image data by a flow velocity data arithmetic section 306, and the color flow image data is supplied to the image processor 304.

The image processor 304 superimposes the B-mode image data and the color flow image data, and outputs the superimposed data to the display 109.

[Principle of Shear Elastic Wave Detection Image]

FIGS. 2 and 3 explain a functional block of a conventional ultrasonic diagnostic device 104 capable of using the ultrasonic pulse to output a color flow image. In the ultrasonic imaging system 101 of the present embodiment, a shear elastic wave detection image can be obtained simply by adding the vibration exciter 106 to the ultrasonic diagnostic device 104, wherein the vibration exciter 106 vibrates at a frequency satisfying Equation (1) and a vibration amplitude satisfying Equation (2). The principle of displaying the shear elastic wave detection image on the display 109 of the ultrasonic diagnostic device 104 is described below.

<Flow Velocity Estimation Algorithm of Color Flow Image>

A flow velocity estimation algorithm, which is the base of the color flow image outputted from the ultrasonic diagnostic device 104 and indicating the velocity of a fluid, will be described first.

Here, when N ultrasonic pulses are transmitted to an arbitrary fluid in the same direction, the phase Φ_i of a reception ultrasonic wave corresponding to the i-th ultrasonic pulse can be expressed as the following Equation (3).

[Mathematical Expression 2]

$$\phi_i = \phi_0 + \frac{2\pi f_0}{c} 2v_i \Delta t \quad (3)$$

where:

Φ_0 represents initial phase

f_0 represents center frequency of ultrasonic wave

c represents sound velocity

v represents flow velocity

Δt represents interval between two adjacent ultrasonic pulses

According to Equation (3), an i-th reception RF signal can be expressed as the following Equation (4).

[Mathematical Expression 3]

$$\begin{aligned} r_i &= r_0 \sin(2\pi f_0 t + \phi_i) \\ &= r_0 \sin\left(2\pi f_0 t + \phi_0 + \frac{2\pi f_0}{c} 2v_i \Delta t\right) \end{aligned} \quad (4)$$

When the reception RF signal of Equation (4) is subjected to a quadrature detection performed by a quadrature detector, its complex quadrature detection output \vec{Q}_i , as well as an in-phase signal I_i (which is a real part signal of \vec{Q}_i) and a quadrature phase signal Q_i (which is an imaginary part signal of \vec{Q}_i) can be expressed as the following Equation (5).

$$\vec{Q}_i = I_i + jQ_i \quad (5)$$

$$\begin{cases} I_i = a \cos\left(\phi_0 + \frac{2\pi f_0}{c} 2v_i \Delta t\right) \\ Q_i = a \sin\left(\phi_0 + \frac{2\pi f_0}{c} 2v_i \Delta t\right) \end{cases}$$

Equation (5) may also be written as the following Equation (6).

[Mathematical Expression 5]

$$\vec{Q}_i = a \exp\left(j\left(\phi_0 + \frac{2\pi f_0}{c} 2v_i \Delta t\right)\right) \quad (6)$$

Here, a difference $\Delta\Phi_0$ between the phase of the ultrasonic pulse and the phase of the (i+1)-th ultrasonic pulse can be estimated as the following Equation (7).

[Mathematical Expression 6]

$$\Delta\Phi_i = \arg(\vec{Q}_{i+1} \vec{Q}_i^*) \quad (7)$$

Since the difference $\Delta\Phi_i$ between the phases of the ultrasonic pulse can be estimated as Equation (7), the following Equation (8) can be obtained when Equation (6) is substituted into Equation (7).

[Mathematical Expression 7]

$$\begin{aligned} \Delta\Phi_i &= \arg\left(a^2 \exp\left(j\frac{2\pi f_0}{c} 2v \Delta t\right)\right) \\ &= \frac{2\pi f_0}{c} 2v \Delta t \end{aligned} \quad (8)$$

Thus, the flow velocity v can be obtained by the following Equation (9).

[Mathematical Expression 8]

$$v = \frac{c}{2\pi f_0 \cdot 2\Delta t} \Delta\Phi_i = \frac{c}{2\pi f_0 \cdot 2\Delta t} \arg(\vec{Q}_{i+1} \vec{Q}_i^*) \quad (9)$$

If an IQ signal is used, the part in the parentheses of Equation can be expressed as the following Equation (10).

[Mathematical Expression 9]

$$\begin{aligned} \vec{Q}_{i+1} \vec{Q}_i^* &= (I_{i+1} + jQ_{i+1})(I_i + jQ_i)^* \\ &= (I_{i+1} + jQ_{i+1})(I_i - jQ_i) \\ &= I_{i+1}I_i + Q_{i+1}Q_i + j(I_iQ_{i+1} - I_{i+1}Q_i) \end{aligned} \quad (10)$$

From Equation (10), the following Equation (11) can be derived as an equation for estimating flow velocity.

[Mathematical Expression 10]

$$v = \frac{c}{2\pi f_0 \cdot 2\Delta t} \arctan\left(\frac{I_i Q_{i+1} - I_{i+1} Q_i}{I_{i+1} I_i + Q_{i+1} Q_i}\right) \quad (11)$$

In the color flow image of the ultrasonic diagnostic device **104**, in order to increase S/N, a quadrature detection output signal obtained from N consecutive ultrasonic pulses is used to estimate the flow velocity with the following Equation (12).

[Mathematical Expression 11]

$$v = \frac{c}{2\pi f_0 \cdot 2\Delta t} \arctan\left(\frac{E_U}{E_L}\right) \quad (12)$$

$$\begin{cases} E_U = \sum_{i=1}^N I_i Q_{i+1} - I_{i+1} Q_i \\ E_L = \sum_{i=1}^N I_{i+1} I_i + Q_{i+1} Q_i \end{cases}$$

<Wave Front Detection of Shear Elastic Wave with Flow Velocity Estimation Algorithm of Color Flow Image>

Here, the flow velocity estimation algorithm of the ultrasonic diagnostic device **104** is applied to a case where the shear elastic wave causes a reflector vibrate sinusoidally.

When the shear elastic wave propagates so that the tissue vibrates sinusoidally, the tissue displacement ξ can be expressed as the following Equation (13).

[Mathematical Expression 12]

$$\xi = \xi_0 \sin(\omega_b t + \Phi_b) \quad (13)$$

Where

ω_b represents vibration angular frequency

Φ_b represents initial phase

At this time, the phase Φ_i of the i-th reception ultrasonic pulse can be expressed as the following Equation (14).

[Mathematical Expression 13]

$$\Phi_i = \Phi_0 + \frac{2\pi f_0}{c} 2\xi \quad (14)$$

Similar to Equation (5), the output of the quadrature detector can be expressed as the following Equation (15).

[Mathematical Expression 14]

$$\begin{cases} I_i = a \cos\left(\phi_0 + \frac{2\pi f_0}{c} 2\xi\right) \\ Q_i = a \sin\left(\phi_0 + \frac{2\pi f_0}{c} 2\xi\right) \end{cases} \quad (15)$$

Here, it is considered that a condition (frequency condition) expressed as the following Equation (16) is satisfied with respect to the angular frequency of the shear elastic wave.

[Mathematical Expression 15]

$$\omega_b = \frac{2\pi}{4\Delta t} \quad (16)$$

In other words, the frequency of the shear elastic wave can be expressed as the following Equation (17).

[Mathematical Expression 16]

$$f_b = \frac{1}{4\Delta t} \quad (17)$$

Further, the initial phase of the vibration satisfies the following Equation (18).

[Mathematical Expression 17]

$$\Phi_b = 0 \quad (18)$$

The aforesaid condition (i.e., Equations (17) and (18)) is a condition that the cycle of the displacement vibration of the tissue caused by the propagation of the shear elastic wave is equal to 4 pulses of the ultrasonic wave and that the initial phase is 0; such condition can be illustrated as FIG. 4.

FIG. 4 is a graph showing a relationship between the cycle and displacement amplitude of the displacement vibration of the tissue caused by the propagation of the shear elastic wave.

The vibration amplitude identical to that of FIG. 4 is also generated in the case where a shear elastic wave with high vibration frequency is folded in a low frequency by aliasing; and at this time, the vibration frequency can be expressed as the following Equation (19), which is Equation (1), where m represents an integer.

[Mathematical Expression 18]

$$f_b = \frac{1}{2} \left(m + \frac{1}{2} \right) \frac{1}{\Delta t} \quad (19)$$

Thus, since the following discussion is also applied to a case where Equation (19) is satisfied, the frequency of the shear elastic wave may satisfy Equation (19). Equation (19) (which is equal to Equation (1)) represents a frequency condition for imaging the shear elastic wave on the ultrasonic diagnostic device **104**.

At this time, the displacement can be expressed as the following Equation (20).

[Mathematical Expression 19]

$$\xi = \xi_0 \sin(2\pi f_b j \Delta t) \quad (20)$$

At this time, I, Q signals, which are the output signals of the quadrature detector, are expressed as the following Equation (21).

[Mathematical Expression 20]

$$\begin{cases} I_i = a \cos\left(\frac{4\pi f_0}{c} \xi\right) \\ Q_i = a \sin\left(\frac{4\pi f_0}{c} \xi\right) \end{cases} \quad (21)$$

Here, in the case where I=0, 1, 3, the output of the quadrature detector is obtained as the following Equations (22), (23), (24), (25), (26), and (27).

[Mathematical Expression 21]

When $i = 0$

$$\begin{cases} I_i = a \\ Q_i = 0 \end{cases}$$

When $i=1$

$$I_i = a \cos\left(\frac{4\pi f_0}{c} \xi_0\right)$$

however, if λ is wavelength of ultrasonic wave

① when $0 \leq \xi_0 \leq \frac{\lambda}{8}$ $\begin{cases} I_i \geq 0 \\ Q_i \geq 0 \end{cases}$

② when $\frac{\lambda}{8} \leq \xi_0 \leq \frac{3\lambda}{8}$ $\begin{cases} I_i \leq 0 \\ Q_i \geq 0 \end{cases}$

When $i=2$

$$\begin{cases} I_i = a \\ Q_i = 0 \end{cases}$$

When $i=3$

$$I_i = a \cos\left(\frac{4\pi f_0}{c} \xi_0\right)$$

however

① when $0 \leq \xi_0 \leq \frac{\lambda}{8}$ $\begin{cases} I_i \geq 0 \\ Q_i \leq 0 \end{cases}$

② when $\frac{\lambda}{8} \leq \xi_0 \leq \frac{3\lambda}{8}$ $\begin{cases} I_i \leq 0 \\ Q_i \leq 0 \end{cases}$

The relationship between Equations (23) to (27) can be expressed as vector diagrams shown in FIGS. 5A and 5B.

FIGS. 5A and 5B are vector diagrams showing the relationship between the amplitudes of the output signal of the quadrature detector for each i -th sample value.

FIG. 5A is a vector diagram in the case where the vibration amplitude ξ_0 satisfies " $0 \leq \xi_0 \leq \lambda/8$ ".

As shown in FIG. 5A, all vectors fall within the first and fourth quadrants.

FIG. 5B is a vector diagram in the case where the vibration amplitude ξ_0 satisfies " $\lambda/8 \leq \xi_0 \leq 3\lambda/8$ ".

As shown in FIG. 5B, when $i=1$ or 3 , the vector falls within the second or third quadrant.

The above discussion is compiled in Table 1.

TABLE 1

(22) 5

Output signal of quadrature detector		
i	I_i	Q_i
0	a	0
1	I_a	Q_a (positive)
2	a	0
3	I_a	$-Q_a$ (negative)

(23) 10

(24) 15

$$\begin{cases} \text{when } 0 \leq \xi_0 \leq \frac{\lambda}{8} & I_a \geq 0 \\ \text{when } \frac{\lambda}{8} \leq \xi_0 \leq \frac{3\lambda}{8} & I_a \leq 0 \end{cases}$$

Next, the estimated flow velocity of the ultrasonic diagnostic device 104 with respect to the patterns shown in the above Table 1 is obtained as below.

First, the flow velocity derivation algorithm expressed as Equation (12) is modeled with two basic operators.

FIG. 6A is a model diagram showing a first basic operator. FIG. 6B is a model diagram showing a second basic operator.

First, the i -th in-phase data and quadrature phase data and the $(i+1)$ -th in-phase data and quadrature phase data are prepared as the outputs of the quadrature detector.

The first basic operator is an operator of a stage before the summation for deriving E_U in Equation (12).

The second basic operator is an operator of a stage before the summation for deriving E_L in Equation (12).

FIG. 7A is a model diagram of the flow velocity derivation algorithm of the ultrasonic diagnostic device 104 in the case where the ultrasonic pulse transmission/reception numbers $N=11$.

FIG. 7E is a view showing a result of the flow velocity estimation in the ultrasonic diagnostic device 104, in a state where two conditions shown Equation (16) and Equation (18) are all satisfied.

In FIG. 7E, E_L is a value satisfying the following Table 2.

TABLE 2

(27) 45

$\begin{cases} \text{when } 0 \leq \xi_0 \leq \frac{\lambda}{8} & E_L \geq 0 \\ \text{when } \frac{\lambda}{8} \leq \xi_0 \leq \frac{3\lambda}{8} & E_L \leq 0 \end{cases}$

50

$E_U=0$ no matter what value E_L is. Thus, for a vector with E_L as the real axis and E_U as the imaginary axis, if E_L is a positive value, the vector will be a vector directed to the positive direction on the real axis, and the estimated flow velocity value will be 0. On the other hand, if E_L is a negative value, the vector will be a vector directed to the negative direction on the real axis, and the estimated flow velocity value will be a positive maximum value or a negative maximum value (a maximum flow velocity value determined by the Nyquist frequency).

In other words, the following conclusion can be derived.

<1> Condition that E_L becomes a positive value (in the case where the vibration amplitude caused by the shear elastic wave satisfies " $0 \leq \xi_0 \leq \lambda/8$ ")

The part of 0 flow velocity will appear on the shear elastic wave detection image when the phase of the vibration amplitude comes to positions of 0° and 180° .

<1> Condition that E_z becomes a negative value (in the case where the vibration amplitude caused by the shear elastic wave satisfies " $\lambda/8 \leq \xi_0 \leq 3\lambda/8$ ")

The part of maximum flow velocity will appear on the shear elastic wave detection image when the phase of the vibration amplitude comes to positions of 0° and 180° .

The above conditions show that, if the amplitude of the shear elastic wave is set to a value satisfying Equation (2), when the phase of the vibration amplitude caused by the shear elastic wave comes to positions of 0° and 180° , striped pattern will appear on the shear elastic wave detection image. The above two conditions are referred to as "amplitude condition" hereinafter.

When the shear elastic wave is propagating in the tissue, the phase (0° and 180°) of the shear elastic wave can be estimated by extracting the aforesaid characteristic part from the color flow image outputted by the ultrasonic diagnostic device **104**. Since the parts of the shear elastic wave having the same phase correspond to reproducing the wave front of the shear elastic wave, the wave front of the shear elastic wave can be reproduced from the color flow image by this method.

This method is for imaging the shear elastic wave, and focuses on a fact that when Equation (1)=Equation (19) is satisfied (which is the frequency condition for imaging the shear elastic wave on the ultrasonic diagnostic device **104**), the estimation algorithm of the ultrasonic diagnostic device **104** becomes a digital filter for detecting phases 0° and 180° of the shear elastic wave.

In other words, when applying a vibration with a frequency of $n/4$ (n represents an odd number equal to or larger than 1) to the object-to-be-measured with respect to the burst frequency corresponding to the repetition cycle of the ultrasonic pulse, the shear elastic wave will appear as a striped pattern on the ultrasonic diagnostic device **104**.

The frequency condition for imaging the shear elastic wave on the ultrasonic diagnostic device **104** is theoretically expressed as Equation (1)=Equation (19); however, actually the frequency of the shear elastic wave does not have to match the frequency condition of the shear elastic wave described above. If the frequency of the vibration becomes close to the frequency condition, the parts where the flow velocity value becomes maximum value or becomes 0 will appear on the display **109** of the ultrasonic diagnostic device **104**; therefore, even in such a case, the wave front (the striped pattern) of the shear elastic wave can be reproduced on the ultrasonic diagnostic device **104** by this method. The allowable frequency range in which the wave front of the shear elastic wave can be reproduced on the ultrasonic diagnostic device **104** is ± 10 Hz at a maximum. As long as the frame rate of the ultrasonic image is a constant, the allowable frequency range does not change even if the burst frequency changes. If more deviation of the frequency occurs, the striped pattern will not be able to be reproduced on the ultrasonic diagnostic device **104**. In the case where a vibration with a frequency matching the allowable frequency range is applied, the moving speed of the striped pattern displayed on the ultrasonic diagnostic device **104** will change in accordance with the change of the frequency.

Further, when a frequency of integral multiple of the frame rate of the ultrasonic diagnostic device **104** exists in the frequency range of the shear elastic wave, it looks as if the striped pattern displayed on the ultrasonic diagnostic device **104** is still at the frequency of integral multiple of the frame rate. In the case where it looks as if the striped pattern is still, if changing the frequency of the vibration from such

frequency, the moving direction of the striped pattern will change in accordance with the increasing/decreasing direction of frequency.

For example, in the case where the frequency of the frame rate of the ultrasonic diagnostic device **104** is 10 Hz and the burst frequency is 365 Hz, the frequency of the shear elastic wave will be 91.25 Hz when $n=1$, or 273.75 Hz when $n=2$. In the case where the frequency of the shear elastic wave is 273.75 Hz, the striped pattern can be reproduced on the ultrasonic diagnostic device **104** in a range of ± 5 Hz, i.e., within a range from 268.75 Hz to 278.75 Hz. Particularly, since 270 Hz, which is integral multiple of the frame rate, exists in such a frequency range, it looks as if the striped pattern displayed on the ultrasonic diagnostic device **104** is still when the frequency of the shear elastic wave is 270 Hz.

<Propagation Velocity Estimation of Shear Elastic Wave Based on Wave Front of Shear Elastic Wave>

When the frequency condition is satisfied, the estimated flow velocity value shows maximum value or 0 at two places near 0° and 180° of the phase of the shear elastic wave. In other words, the wavelength of the shear elastic wave can be obtained by performing image processing to extract such part, and thereby the propagation velocity of the shear elastic wave can be estimated. To be specific, the following two methods can be used.

Method 1 (Estimation Method Based on Spatial Distribution of Flow Velocity)

Two-dimensional autocorrelation of an image on which the wave front of the shear elastic wave is recorded is calculated. A distance d over which a phase rotation caused by the propagation of the shear elastic wave becomes 180° can be obtained based on the peak or the correlation or the gravity center position of correlation value. Thus, the propagation velocity v_s of the shear elastic wave can be calculated using the following Equation (28). More strictly, the distance d needs to be corrected with respect to the interval between the striped pattern appearing on the screen of the display device **108** when considering the delay of the transmission time inherent to the ultrasonic diagnostic device **104** occurring when transmitting the ultrasonic pulse from the ultrasonic probe **103**; and details about such correction is omitted herein.

[Mathematical Expression 22]

$$V_s = 2d * f_b \quad (28)$$

Method 2 (Estimation method based on movement of wave fronts of two past frames.)

Two-dimensional mutual correlation functions of two images separated from each other by time T are calculated. A distance over which a phase rotation caused by the propagation of the shear elastic wave becomes 180° can be obtained based on the peak or the correlation or the gravity center position of correlation value. Thus, the propagation velocity v_s of the shear elastic wave can be calculated using the above Equation (28).

[Configuration of CFI Image Processing Device **107**]

FIG. 8 is a block diagram showing a hardware configuration of the CFI image processing device **107**.

The CFI image processing device **107** configured by a widely known personal computer is formed by connecting a CPU **801**, a ROM **802**, a RAM **803**, a non-volatile storage **804** (such as a hard disk device), display device **108**, an operating portion **805**, and a USE interface **806** (referred to as "USE I/F" in FIG. 8) to a bus **807**.

FIG. 9 is a functional block diagram of the CFI image processing device **107**.

The ultrasonic probe **103** emits an ultrasonic pulse to a body tissue **901** of the subject **102**, and receives the ultrasonic pulse.

Similarly, the vibration exciter **106** driven by the shear elastic wave driving circuit **105** applies a shear elastic wave to the body tissue **901**.

The ultrasonic diagnostic device **104** outputs the color flow image.

The CFI image processing device **107** is formed by causing the widely known personal computer described above with reference to FIG. **8** to execute a program that allows the personal computer to act as the CFI image processing device **107**.

Digital image data (which is not only color flow image data, but also shear elastic wave detection image data) outputted from the ultrasonic diagnostic device **104** is inputted to a flow velocity image extractor **902** and a B-mode image extractor **903**.

The flow velocity image extractor **902** extracts the color flow image data from the digital image data. The flow velocity image extractor **903** extracts the B-mode image data from the digital image data. In many cases, the digital image data outputted from the ultrasonic diagnostic device **104** has a display area of the color flow image appearing in a center portion of the black-and-white B-mode image. Thus, the flow velocity image extractor **902** and the B-mode image extractor **903** can be integrally configured by extracting the color portion with the help of coordinate information. In other words, the flow velocity image extractor **902** and the B-mode image extractor **903** are in an exclusive relationship.

The color flow image data outputted from the flow velocity image extractor **902** is inputted to an amplitude condition matching image extractor **904**. The amplitude condition matching image extractor **904** extracts components of the image data that matches the amplitude condition (i.e., components of the image data that satisfies Equation (2)) from the color flow image data. The amplitude condition is provided to the amplitude condition matching image extractor **904** by inputting frequency information of the ultrasonic probe **103** and shear elastic wave driving circuit **105** (synchronous oscillator **208**) from the operating portion **805**. To be specific, for example, if the amplitude is a value matching the amplitude condition, since the maximum flow velocity value appears on the color flow image, the image matching the amplitude condition is extracted with the fact that the maximum flow velocity value appears on the image as a criterion.

The amplitude condition matching image data outputted from the amplitude condition matching image extractor **904** is inputted to a shear elastic wave wave-front image configuration section **905**. The shear elastic wave wave-front image configuration section **905** reproduces the wave front of the shear elastic wave from the amplitude condition matching image data outputted by the amplitude condition matching image extractor **904**. To be specific, for example, a flow velocity value equal to half of the maximum flow velocity is used as a threshold, and the wave front of the shear elastic wave is reproduced by performing a processing so that if the flow velocity value is equal to or larger than the threshold, the flow velocity value will be treated as 1; and if the flow velocity value is smaller than the threshold, the flow velocity value will be treated as 0.

The shear elastic wave wave-front image data outputted from the shear elastic wave wave-front image configuration section **905** is inputted to a shear elastic wave wavelength estimation section **906**. The shear elastic wave wavelength

estimation section **906** uses two-dimensional correlation from the shear elastic wave wave-front image data to estimate the wavelength of the shear elastic wave in the shear elastic wave wave-front image data.

The shear elastic wave wavelength data outputted from the shear elastic wave wavelength estimation section **906** is inputted to a shear elastic wave velocity estimation section **907**. The shear elastic wave velocity estimation section **907** estimates the propagation velocity of the shear elastic wave from the shear elastic wave wavelength data. The estimated propagation velocity data of the shear elastic wave is plotted into lines like contour lines of a map, for example.

The B-mode image data outputted from the B-mode image extractor **903**, the shear elastic wave wave-front image data outputted from the shear elastic wave wave-front image configuration section **905**, and the propagation velocity data of the shear elastic wave outputted from the shear elastic wave velocity estimation section **907** are inputted to a reproduction image superimposing section **908**. The reproduction image superimposing section **908** superimposes the B-mode image data, the shear elastic wave wave-front image data, and the propagation velocity data of the shear elastic wave onto each other to reconfigure integral image data.

The image data outputted from the reproduction image superimposing section **908** is inputted to the display device **108** where a shear elastic wave display image including the striped pattern of the shear elastic wave is displayed.

FIG. **10** is a view showing examples of a shear elastic wave detection image displayed on the ultrasonic diagnostic device **104** and the shear elastic wave display image displayed on the display device **108** of the ultrasonic imaging system **101** of the present embodiment. The images shown in FIG. **10** are shear elastic wave detection images and shear elastic wave display images obtained when measuring a pseudo living body phantom with the ultrasonic imaging system **101**, wherein the pseudo living body phantom is created by mixing graphite powder, which scatters the ultrasonic wave, into agar. Three pseudo living body phantoms with different agar concentration are created. The three pseudo living body phantoms have an agar concentration of 1.75%, 1.5% and 1% respectively.

Image (a) of FIG. **10** is a shear elastic wave detection image obtained when the agar concentration is 1.75%.

Image (b) of FIG. **10** is a shear elastic wave detection image obtained when the agar concentration is 1.5%.

Image (c) of FIG. **10** is a shear elastic wave detection image obtained when the agar concentration is 1%.

Image (d) of FIG. **10** is a shear elastic wave display image obtained when the agar concentration is 1.75%.

Image (e) of FIG. **10** is a shear elastic wave display image obtained when the agar concentration is 1.5%.

Image (f) of FIG. **10** is a shear elastic wave display image obtained when the agar concentration is 1%.

It can be known from images (a), (b) and (c) of FIG. **10** that, although each shear elastic wave detection image includes much noise, a characteristic striped pattern caused by the shear elastic wave appears on the image.

Higher agar concentration means the phantom has higher stiffness, and therefore the shear elastic wave has higher the propagation velocity. In other words, the shear elastic wave has longer wavelength. Conversely, lower agar concentration means the phantom has lower stiffness, and therefore the shear elastic wave has lower propagation velocity. In other words, the shear elastic wave has shorter wavelength. The results of FIG. **10** show that the difference in stiffness of the agar can be discriminated as the difference in wavelength of the shear elastic wave.

Further, it can be known images (d), (e) and (f) of FIG. 10 that, in a shear elastic wave display image, since noise component is remarkably removed compared with the shear elastic wave detection image, the intervals of the striped pattern can be more clearly recognized. Incidentally, it is preferred that, when measuring the intervals of the striped Pattern, the intervals of white (or light-colored) parts are measured. This is because the parts where the flow velocity is (the black or light-colored parts) are susceptible to the effect of the noise, and therefore it is expected to reduce the error by measuring the parts which show maximum flow velocity.

Further, the striped pattern actually moves on the screen, although such movement cannot be recognized in images shown in FIG. 10 as these images are still images. The moving speed varies depending on the frequency difference and phase difference between the frequency of the shear elastic wave satisfying Equation (1) and the frequency of the shear elastic wave actually supplied from the vibration exciter 106, and the phase difference. The transmission direction of the shear elastic wave can be visually recognized from the moving direction of the striped pattern. Further, the transmission direction of the shear elastic wave can be obtained as vector data by performing image analysis on the moving direction of the striped pattern. The transmission direction of the shear elastic wave can be visualized by displaying the vector data showing the transmission direction of the shear elastic wave as an illustration of arrow marks, for example, on the display device 108. Since the transmission direction of the shear elastic wave can be visualized, various abnormalities in body tissue can be clearly estimated. For example, tissue boundary surface can be clearly visualized from the refraction of the shear elastic wave. Further, in the case where tissue adhesion occurs, the same vibration is transmitted by two adherent tissues. Thus, information such as the facts that refraction is unlikely to occur, that the propagation direction does not change, and the like can be obtained. Further, in the case of diseases such liquefaction degeneration like fibroid, the propagation direction of the shear elastic wave will become locally uneven. Thus, the fact that the tissue is liquefaction degeneration can be clearly known from the propagation direction of the shear elastic wave.

The aforesaid embodiment includes the following applications.

(1) In the aforesaid embodiment, the ultrasonic imaging system 101 is built in which the existing ultrasonic diagnostic device 104 is used in its entirety; however, the present invention also includes a configuration in which the ultrasonic diagnostic device 104 includes the arithmetic function of the CFI image processing device 107.

(2) In the aforesaid embodiment, in order to further improve the clarity of the shear elastic wave display image, a shear elastic wave with two or more frequencies may be used to vibrate the object-to-be-measured.

In the reproduction of the wave front of the shear elastic wave by the ultrasonic diagnostic device 104, when the frequency matching the frequency condition satisfies the amplitude condition, characteristic flow velocity value is estimated near the phases 0° and 180° of the shear elastic wave; and such fact is used to reproduce the wave front of the shear elastic wave.

In other words, when the displacement amplitude becomes the data row shown in FIG. 4 with respect to ultrasonic pulse, the wave front of the shear elastic wave can be reproduced.

The pattern of the displacement amplitude for each ultrasonic pulse shown in FIG. 4 can be achieved not only in the case where there is one shear elastic wave with single frequency, but also in the case where a plurality of shear elastic waves matching the frequency condition are excited simultaneously while the summed vibration amplitudes satisfy the condition of FIG. 4.

In the excitation of the shear elastic wave with one frequency, in order to reach a maximum flow velocity value, the following Equation (29) is required to be satisfied.

[Mathematical Expression 23]

$$\frac{\lambda}{8} \leq \xi_0 \leq \frac{3\lambda}{8} \quad (29)$$

However, in the case where the plurality of shear elastic waves matching the frequency condition are excited simultaneously, the "sum of amplitudes" may satisfy the above condition when the ultrasonic pulse is being transmitted.

When using such fact, if the initial phases of the displacement amplitudes of two shear elastic waves (for example, one is a shear elastic wave whose vibration amplitude is $\xi_{0,0}$ at frequency $m=0$, and the other is a shear elastic wave whose vibration amplitude is $\xi_{0,1}$ at frequency $m=1$ with respect to the frequency condition Equation (19), which is equal to Equation (1)) are selected so that the displacement amplitudes of the two shear elastic waves at maximum amplitudes are in phase and overlapped with each other, the amplitude condition when the flow velocity becomes maximum can be rewritten into the following Equation (30).

[Mathematical Expression 24]

$$\frac{\lambda}{8} \leq \xi_{0,0} + \xi_{0,1} \leq \frac{3\lambda}{8} \quad (30)$$

The following are advantages of using the plurality of frequencies simultaneously.

<1> The higher the frequency of the shear elastic wave is, an image with the higher spatial resolution can be obtained; however, if the frequency of the shear elastic wave is increased, attenuation of the shear elastic wave will increase, and therefore it is difficult to obtain large vibration amplitude, so that it becomes difficult to satisfy the amplitude condition in which the estimated flow velocity becomes maximum. However, if a low frequency (vibration amplitude: $\xi_{0,0}$) with less attenuation and a high frequency (vibration amplitude: $\xi_{0,1}$) for imaging are excited simultaneously, since the amplitude condition is eased as Equation (30),

<2> Since simultaneously exciting the shear elastic waves with a plurality of frequencies with the phases matched each other corresponds to previously biasing the vibration amplitudes, even the wave fronts of the shear elastic waves with high frequencies and small vibration amplitudes can be reproduced with high sensitivity by using the present method of simultaneously exciting the plurality of frequencies.

(3) In the aforesaid embodiment, the object-to-be-measured is excited with the vibration exciter 106; however, the means for generating a shear elastic wave is not limited to the vibration exciter 106. The ultrasonic probe 103 may also be integrated with the vibration exciter 106.

It is also possible to cause one of the plurality of ultrasonic transducers **202** contained in the ultrasonic probe **103** to generate a strong ultrasonic wave using the acoustic radiation pressure method to thereby generates a shear elastic wave with the ultrasonic probe **103** alone by means of space division.

Further, it is also possible to alternately change over between the time while the strong ultrasonic wave is generated using the acoustic radiation pressure method and the time while the ultrasonic pulse for image reproduction is generated to thereby generates a shear elastic wave with the ultrasonic probe **103** alone by means of time division.

In other words, a concept of “shear elastic wave generator” is used a generic concept of the means for generating the shear elastic wave.

In the present embodiment, the ultrasonic imaging system **101** is described.

The existing ultrasonic diagnostic device **10** is used to obtain a color flow image of a target object whose stiffness is to be measured. At this time, the vibration exciter **106** applies micro vibration with a frequency of $n/4$ (n represents an odd number equal to or larger than 1) to the target object with respect to the burst frequency of the ultrasonic pulse to generate a shear elastic wave. As a result, a striped pattern corresponding to the stiffness of the target object caused by the shear elastic wave appears on the display **109** of the ultrasonic diagnostic device **104** as a shear elastic wave detection image. Further, a shear elastic wave display image with reduced noise can be obtained by performing a predetermined arithmetic processing on shear elastic wave detection image data.

Thus, according to the present embodiment, the stiffness of the object-to-be-measured can be easily measured by adding a relatively simple device.

The embodiment of the present invention is described as above; however, it is to be understood that the present invention is not limited to the embodiment described above, and various modifications and applications can be made without departing from the spirit described in the claims of the present invention.

For example, in the aforesaid embodiment, the configurations of the device and system are described in detail and concrete manner so that the present invention is easily understandable; however, the aforesaid configurations do not have to be fully included. Further, configurations of one embodiment can be partly substituted with configurations of other embodiments, and configurations of one embodiment can be added with a configuration(s) of other embodiments. Further, configurations of one embodiment can be partly omitted, or added with other configuration(s), or substituted with other configurations.

Further, the aforesaid each configuration, function, processor and the like can be partly or entirely achieved by hardware by being designed using an integrated circuit, for example. Further, the aforesaid each configuration, function and the like can be achieved by software whose processor explains and executes a program that achieves respective functions. Information such as the program, tables, files and the like for achieving each function can be stored in a volatile or non-volatile storage, such as a memory, a hard disk, a SSD (solid state drive) or the like, or a recording medium, such as an IC card, an optical disk or the like.

Further, a control line and an information line are shown because it is required for description, but the product does not necessarily show the control line and information line. It can be considered that almost all configurations are actually connected with each other.

REFERENCE SIGNS LIST

- 101** ultrasonic imaging system
- 102** subject
- 103** ultrasonic probe
- 104** ultrasonic diagnostic device
- 105** shear elastic wave driving circuit
- 106** vibration exciter
- 107** CFI image processing device
- 108** display device
- 109** display
- 201** oscillator
- 202** ultrasonic transducer
- 203** frequency divider
- 204** first multiplexer
- 205** second multiplexer
- 206** first multiplier
- 207** second multiplier
- 208** synchronous oscillator
- 209** first A/D converter
- 210** 90° phase shifter
- 211** second A/D converter
- 212** arithmetic processor
- 301** first sample buffer
- 302** second sample buffer
- 303** B-mode image processor
- 304** image processor
- 305** noise removal arithmetic processor
- 306** flow velocity data arithmetic section
- 801** CPU
- 802** ROM
- 803** RAM
- 804** non-volatile storage
- 805** operating portion
- 806** USB interface
- 807** bus
- 901** body tissue
- 902** flow velocity image extractor
- 903** B-mode image extractor
- 904** amplitude condition matching image extractor
- 905** shear elastic wave wave-front image configuration section
- 906** shear elastic wave wavelength estimation section
- 907** shear elastic wave velocity estimation section
- 908** reproduction image superimposing section

The invention claimed is:

1. An ultrasonic imaging system comprising:
 - an ultrasonic image forming device configured to generate an ultrasonic pulse for measuring an inside structure of an object-to-be-measured in a non-invasive manner, emit the ultrasonic pulse from an ultrasonic probe, and receive a reflected signal in response to the ultrasonic pulse emitted; and
 - a shear elastic wave generator configured to apply a vibration with a predetermined frequency to the object-to-be-measured, to thereby generate a shear elastic wave causing an image of a striped pattern depending on a stiffness of the object-to-be-measured, wherein a first position of the ultrasonic probe and a second position of the shear elastic wave generator are located differently from each other so that the ultrasonic pulse from the ultrasonic probe and the vibration from the shear elastic wave generator are transmitted to the object-to-be-measured from different positions, the ultrasonic image forming device images the stiffness of the object-to-be-measured based on the vibration and the ultrasonic pulse for diagnosing a disease,

wherein, the shear elastic wave generator applies the vibration with a frequency of $n/4$, wherein n represents an odd number equal to or greater than 1, as a center frequency to the object-to-be-measured, with respect to a burst frequency corresponding to a repetition cycle of the ultrasonic pulse. 5

2. The ultrasonic imaging system according to claim 1, wherein the shear elastic wave generator applies the vibration to the object-to-be-measured, wherein the predetermined frequency of the vibration falls in a range of ± 10 Hz at most with respect to the center frequency. 10

3. The ultrasonic imaging system according to claim 2 further comprising:

a color flow image (CFI) processing device configured to receive input data of a color flow image outputted from the ultrasonic image forming device and output image data including information about the stiffness of the object-to-be-measured. 15

4. The ultrasonic imaging system according to claim 3, wherein the CFI processing device is further configured to estimate the stiffness of the object-to-be-measured by estimating, based on the color flow image, a wavelength of a shear elastic wave generated in the object-to-be-measured based on a vibration frequency of the shear elastic wave generator. 20 25

5. The ultrasonic imaging system according to claim 4, wherein the CFI processing device is further configured to include information about a propagation direction of the shear elastic wave by estimating the wavelength of the shear elastic wave. 30

* * * * *

专利名称(译)	超声波成像系统		
公开(公告)号	US10624610	公开(公告)日	2020-04-21
申请号	US15/301283	申请日	2015-03-25
[标]申请(专利权)人(译)	国立大学法人群馬大学		
申请(专利权)人(译)	国立大学法人群馬大学		
当前申请(专利权)人(译)	国立大学法人群馬大学		
[标]发明人	YAMAKOSHI YOSHIKI		
发明人	YAMAKOSHI, YOSHIKI		
IPC分类号	A61B8/08 A61B8/14 A61B8/00 A61B8/06		
CPC分类号	A61B8/0833 A61B8/14 A61B8/06 A61B8/488 A61B8/461 A61B8/485 A61B8/5223		
优先权	2014076527 2014-04-02 JP		
其他公开文献	US20170014104A1		
外部链接	Espacenet		

摘要(译)

现有的超声诊断设备用于获得要测量其刚度的目标物体的彩色流图像。此时，振动激励器相对于超声波脉冲的猝发频率对目标物体施加频率为 $n/4$ (n 表示等于或大于1的奇数) 的微振动，以产生剪切弹性波。结果，对应于由剪切弹性波引起的目标物体的刚度的条纹图案作为剪切弹性波检测图像出现在超声诊断装置的显示器上。

