



(19) **United States**

(12) **Patent Application Publication**
Tripathi

(10) **Pub. No.: US 2012/0101388 A1**

(43) **Pub. Date: Apr. 26, 2012**

(54) **SYSTEM FOR LOCATING ANATOMICAL OBJECTS IN ULTRASOUND IMAGING**

(52) **U.S. Cl. 600/459**

(57) **ABSTRACT**

(76) **Inventor: Gaurav Tripathi, Lucknow (IN)**

(21) **Appl. No.: 13/153,726**

(22) **Filed: Jun. 6, 2011**

Related U.S. Application Data

(60) **Provisional application No. 61/394,793, filed on Oct. 20, 2010.**

Publication Classification

(51) **Int. Cl. A61B 8/00 (2006.01)**

An ultrasound imaging probe supports determination of the location of an object scanned within a 3D volume. A handheld movable ultrasound imaging device emits ultrasound waves and detects corresponding ultrasound waves reflected from an object. At least three light emitting elements are mounted on the ultrasound imaging device and are detectable by a camera located at a fixed position with respect to a 3D volume where the object is imaged. A motion detector provides data indicating detected movement of the ultrasound imaging device in at least one axis. The data indicating detected movement is used together with distance data indicating distance of the ultrasound imaging device from the camera derived using the light emitting elements and the camera, to determine a location of the object scanned within a 3D volume using the ultrasound imaging device.

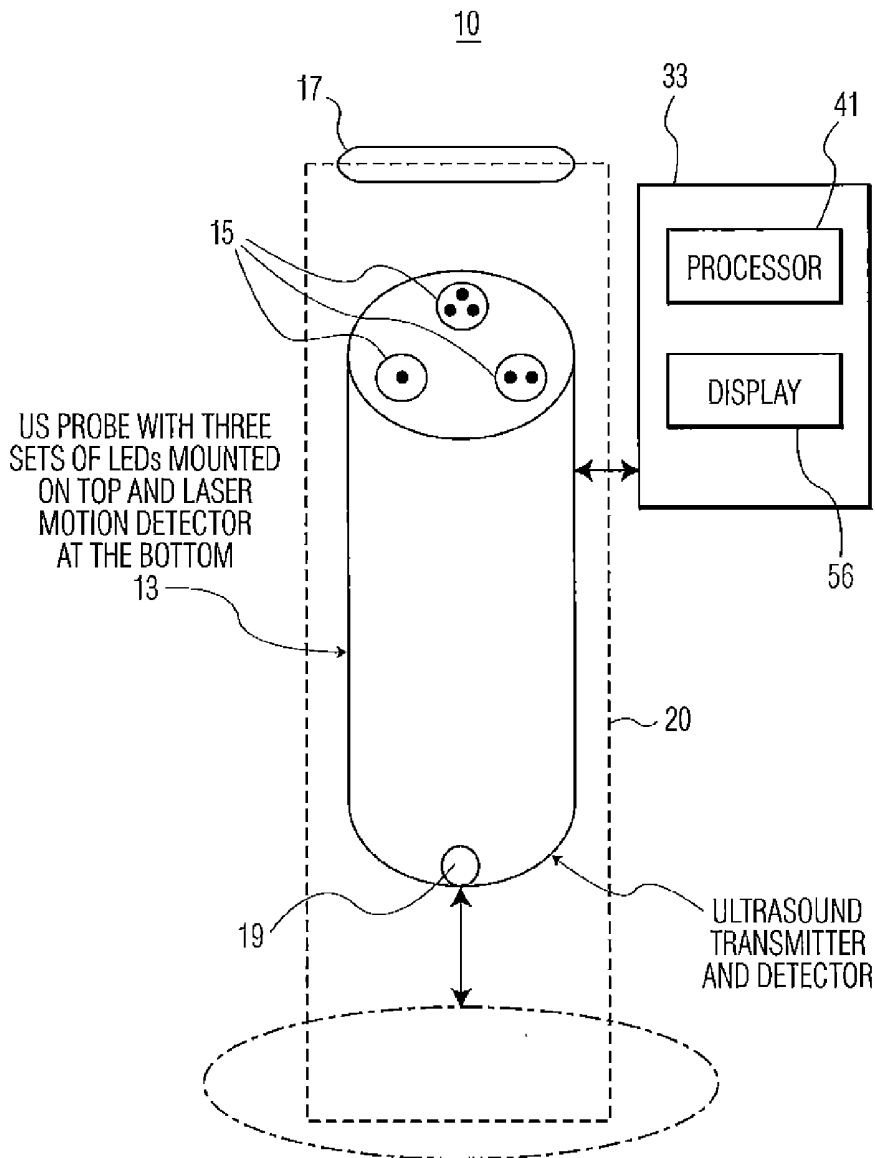

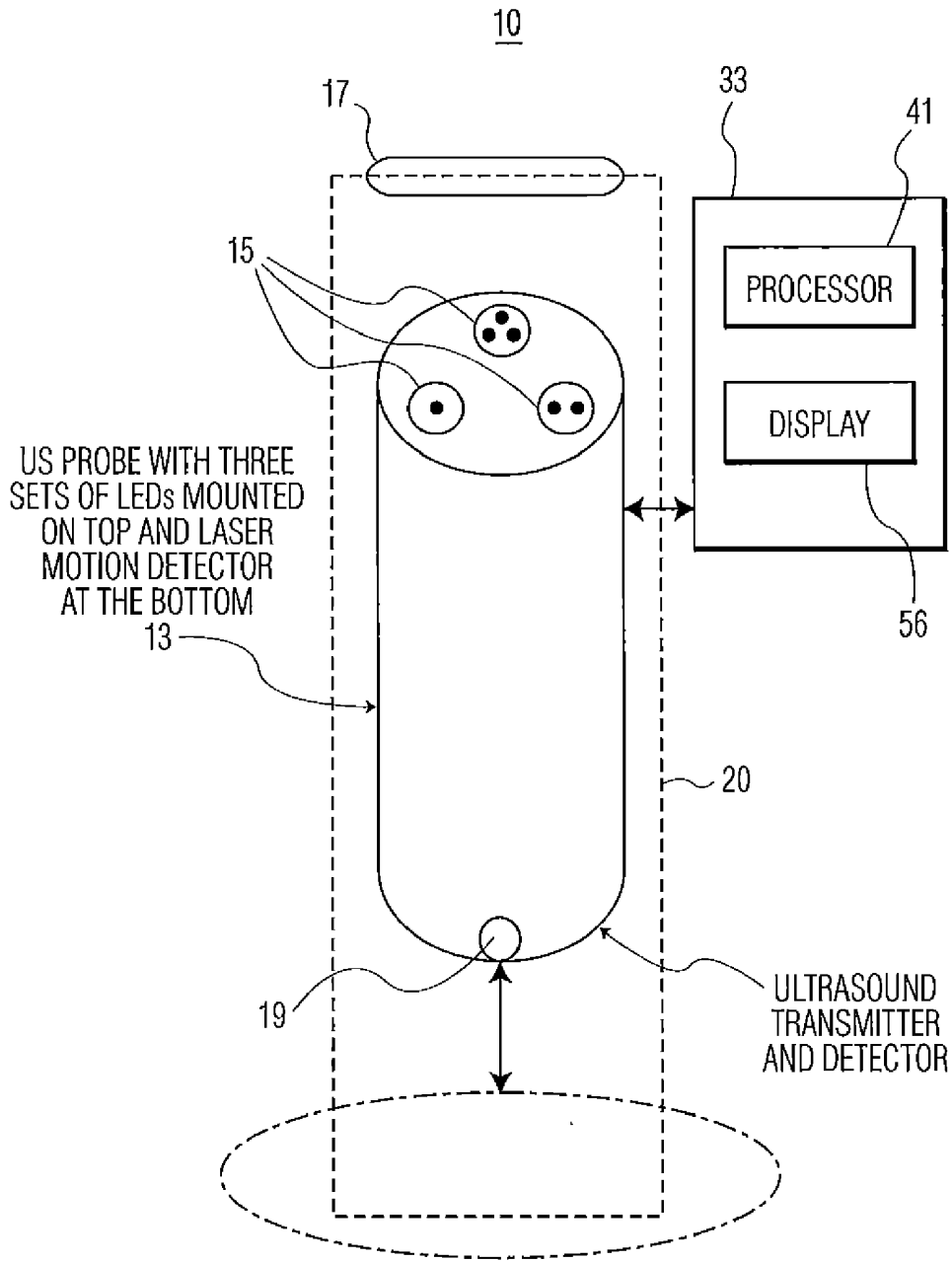

FIG. 1

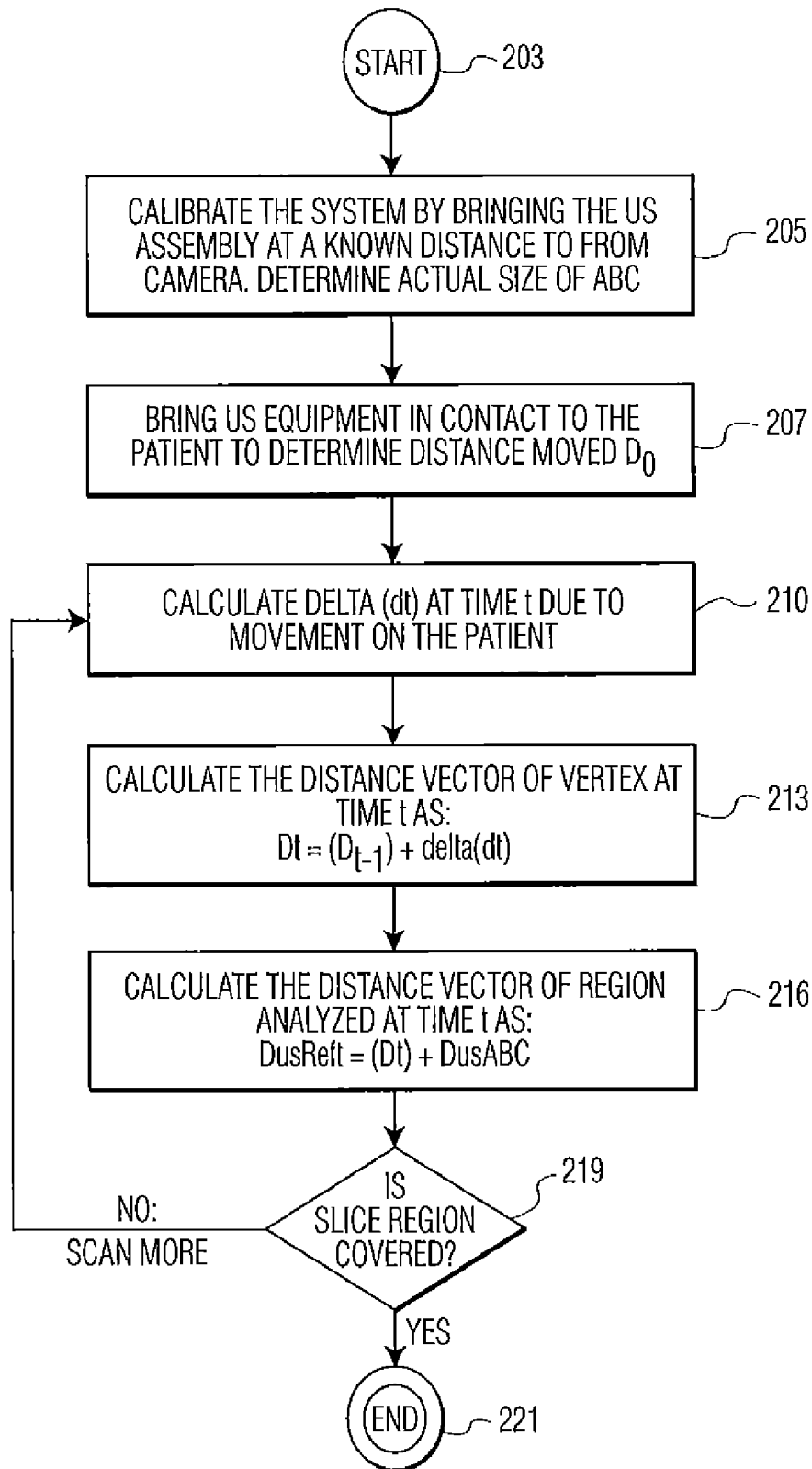

FIG. 2

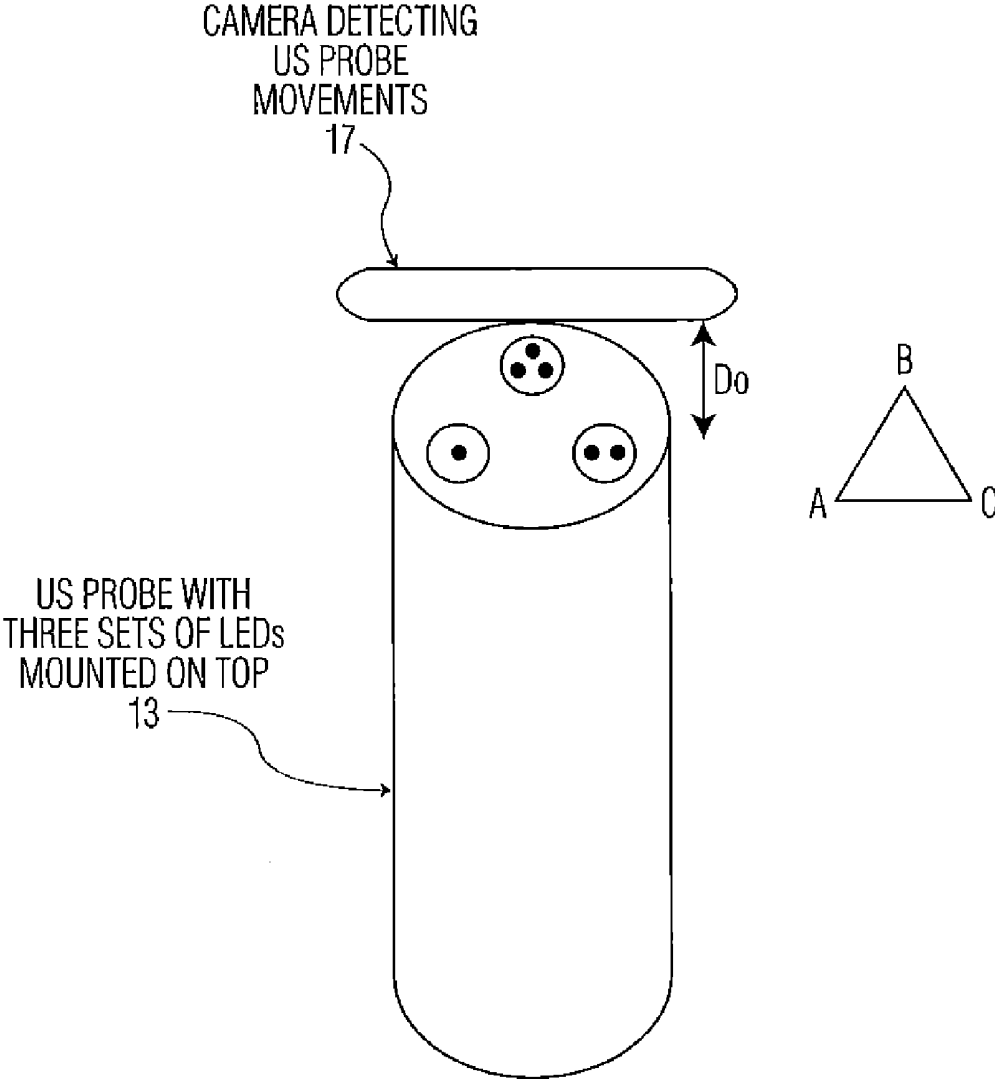

FIG. 3

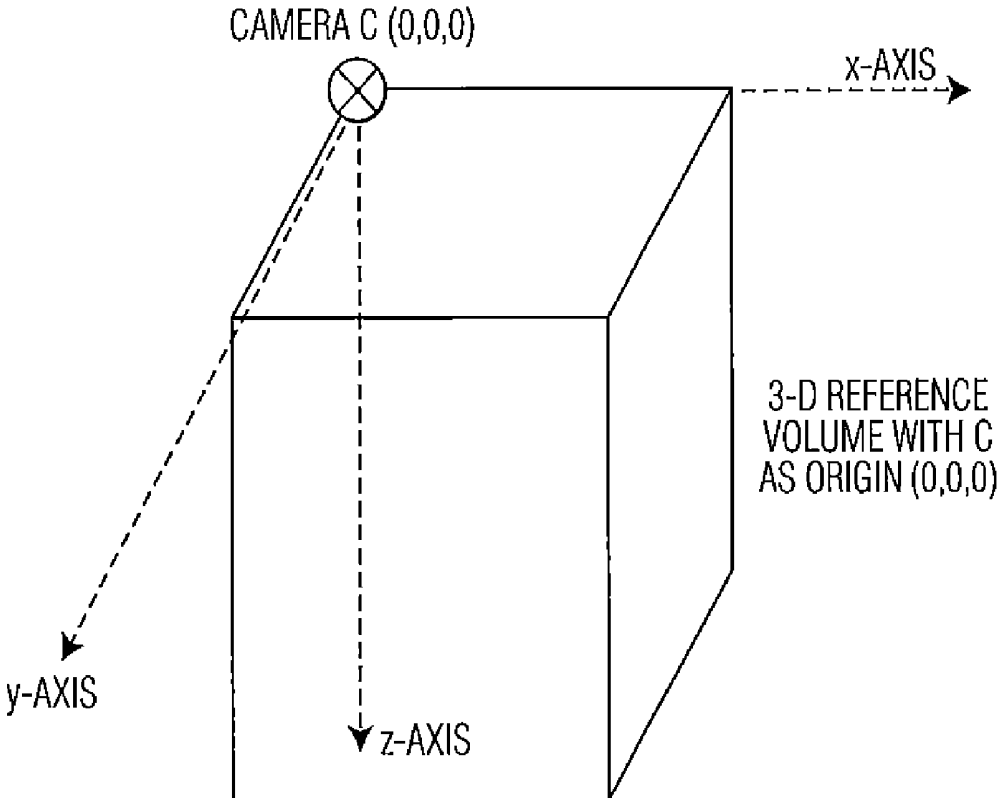

FIG. 4

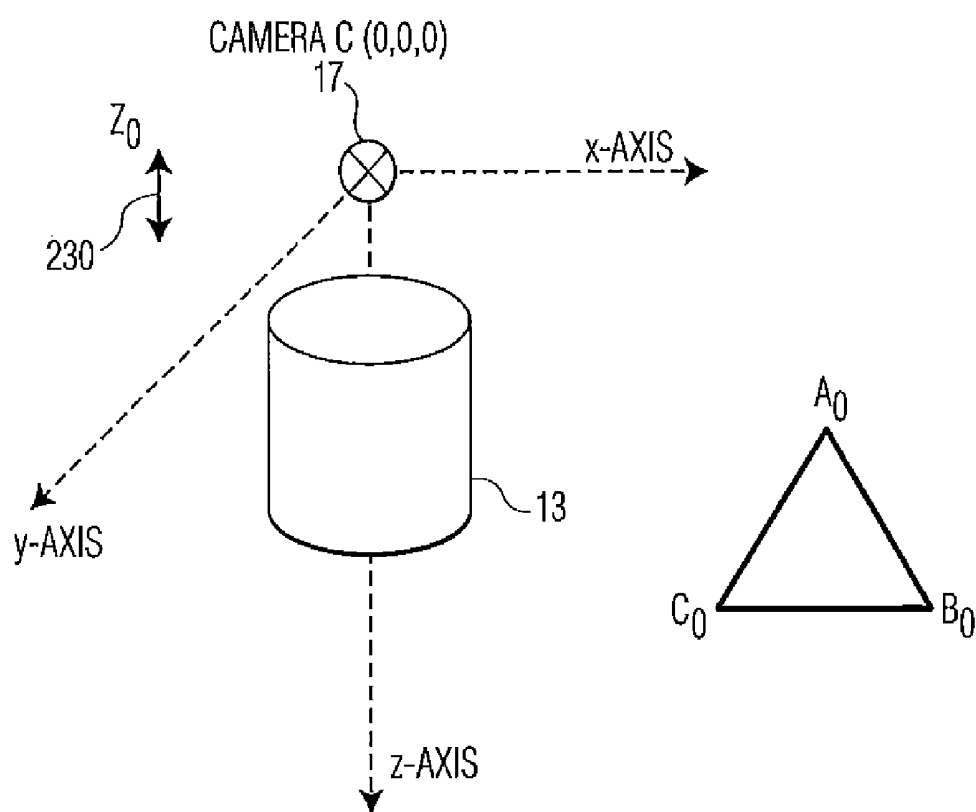

FIG. 5

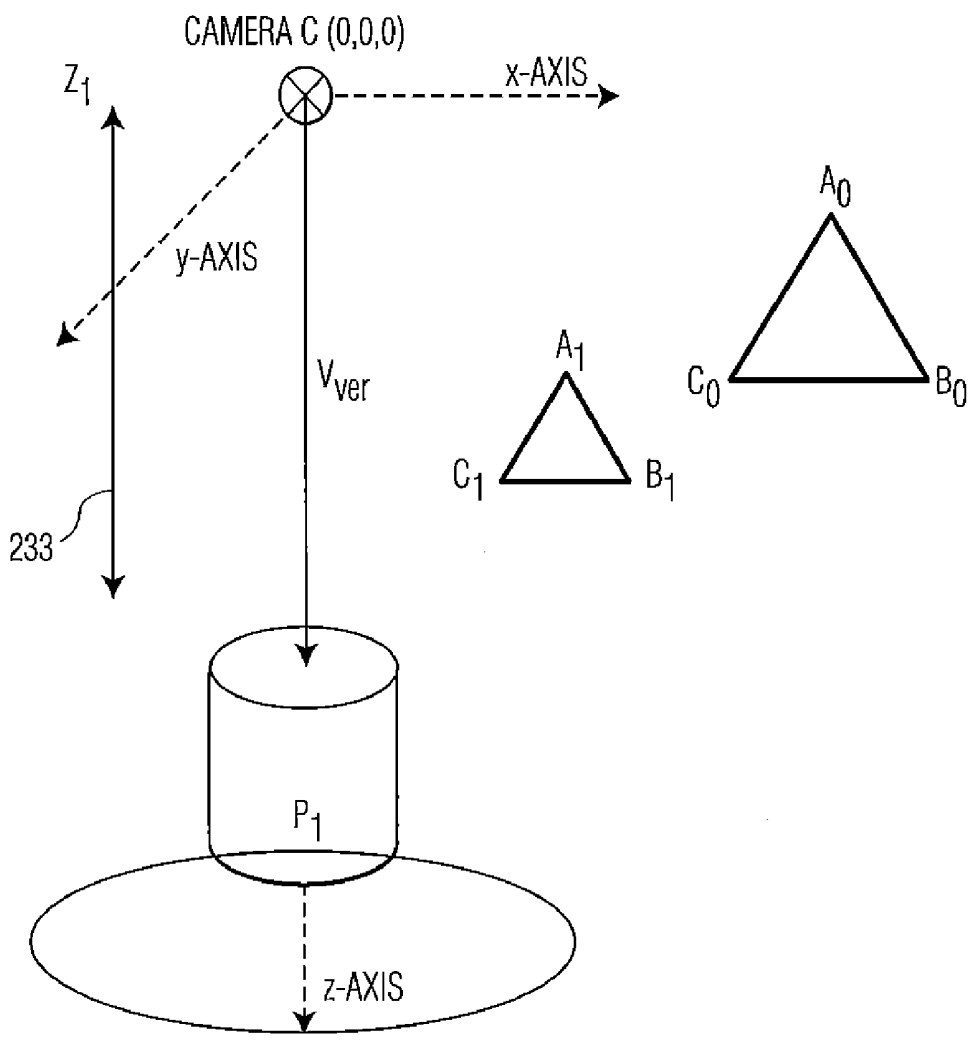

FIG. 6

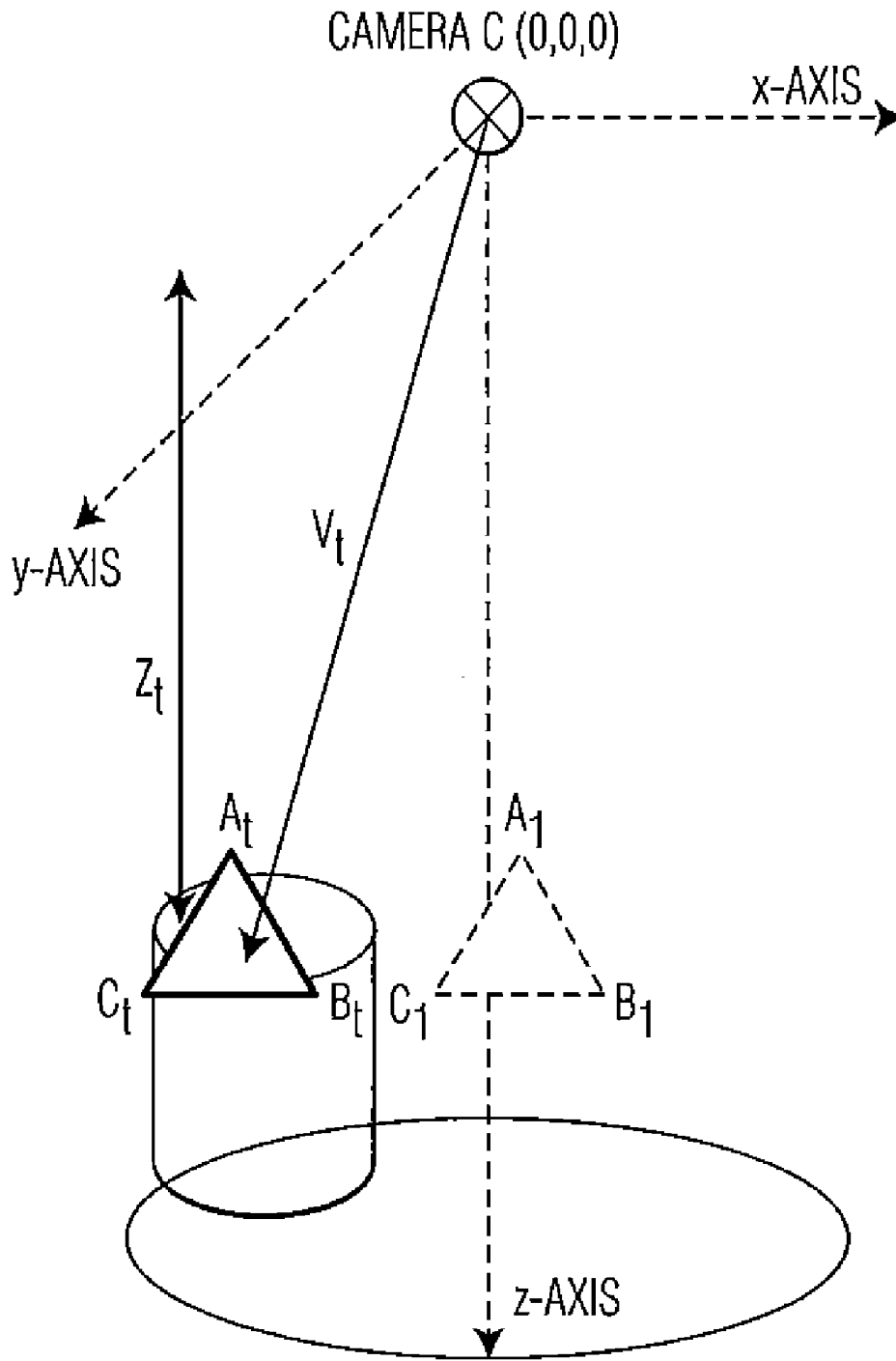

FIG. 7

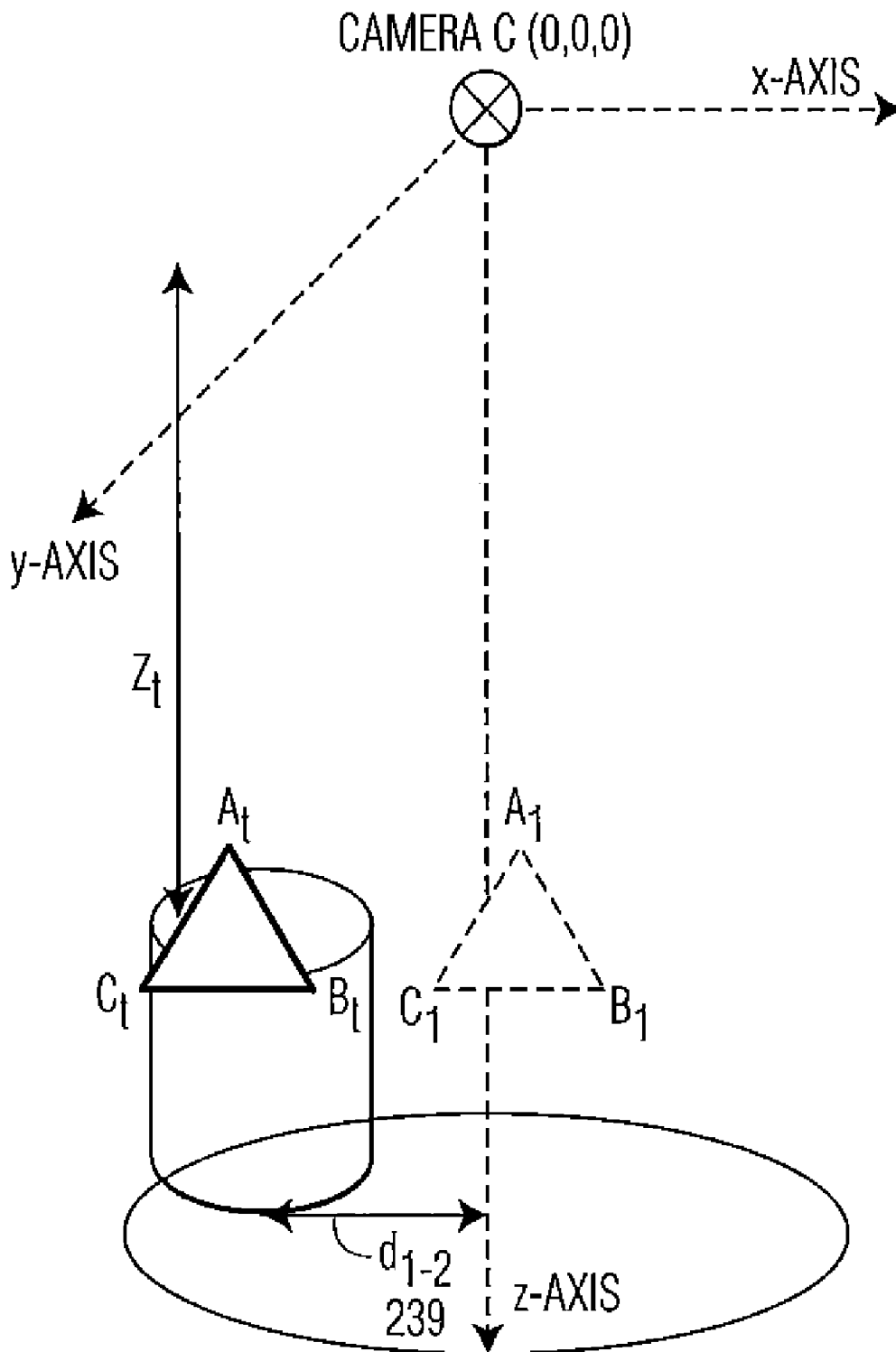

FIG. 8

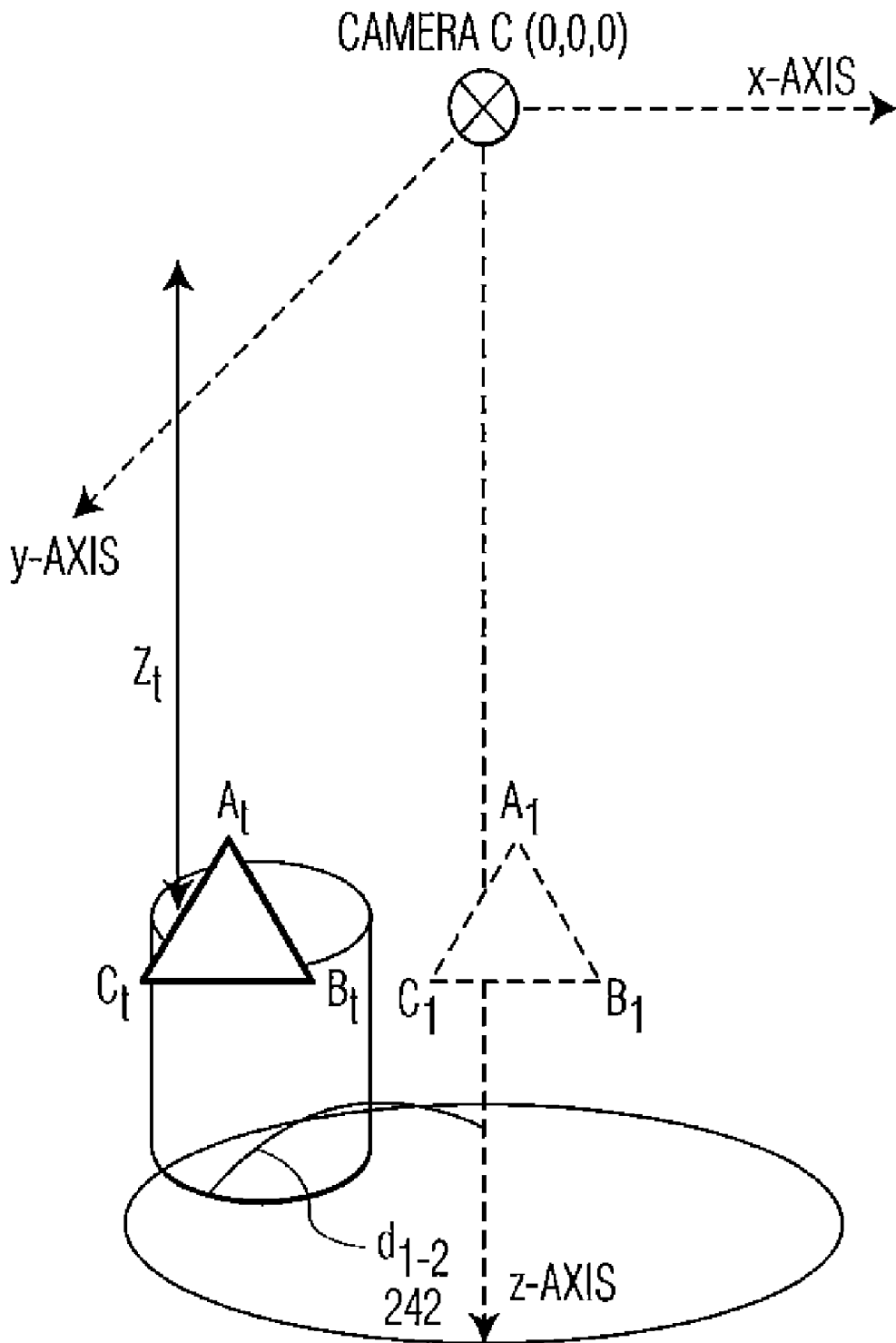

FIG. 9

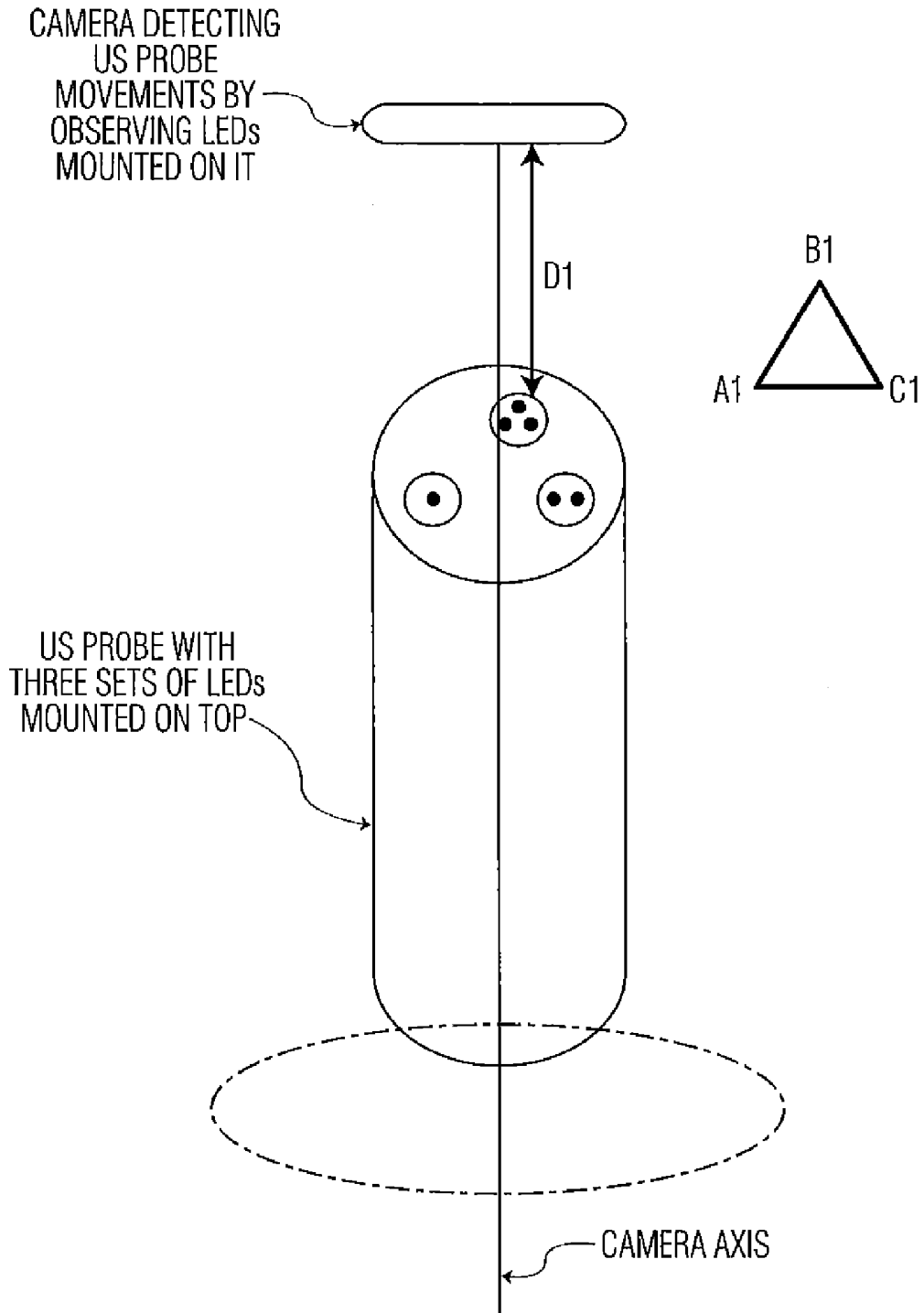

FIG. 10

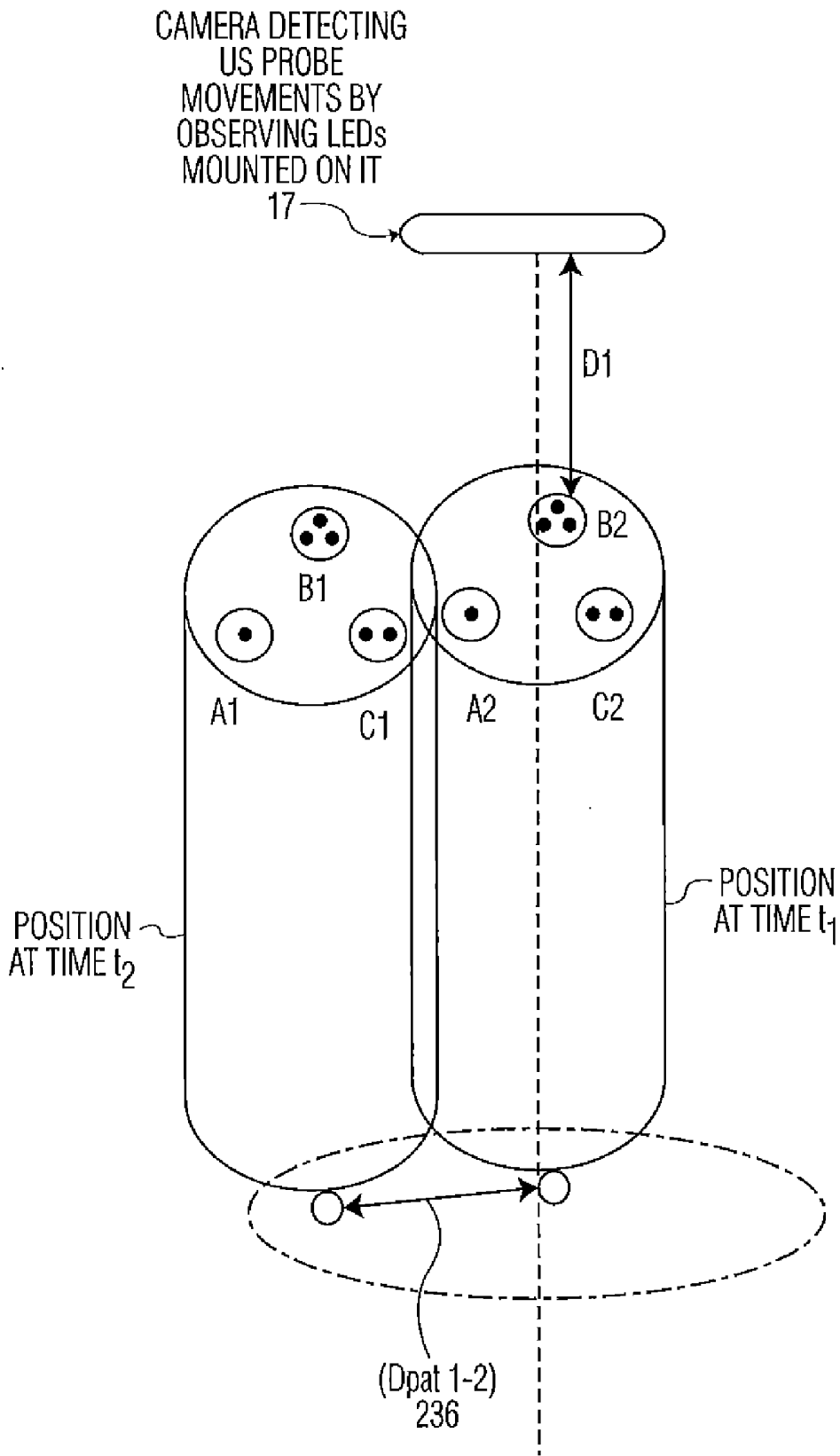

FIG. 11

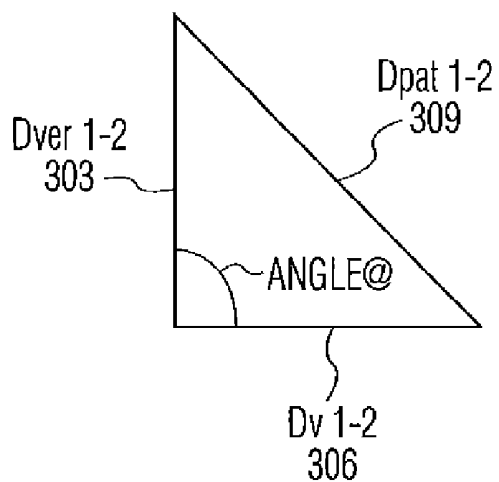

FIG. 12

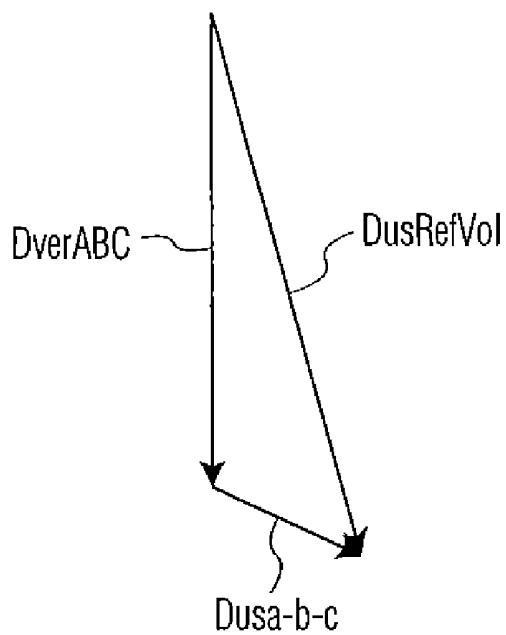

FIG. 13

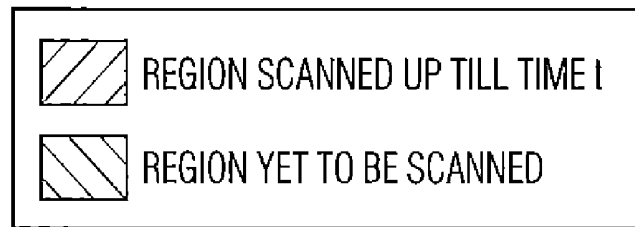
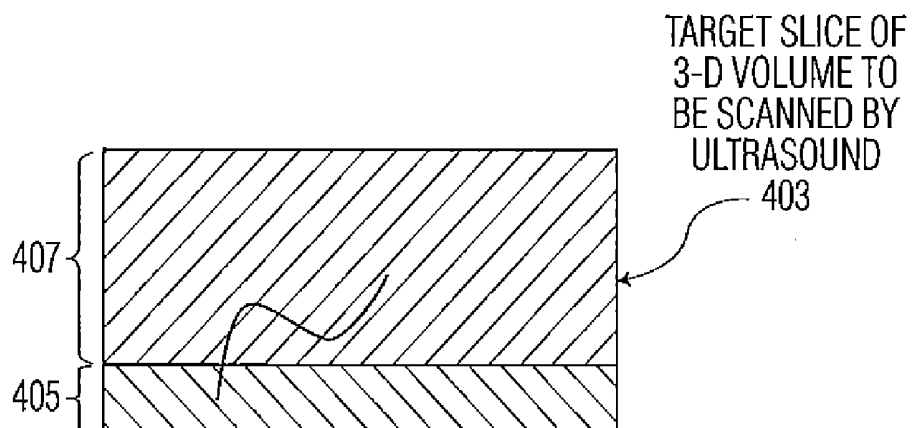

FIG. 14

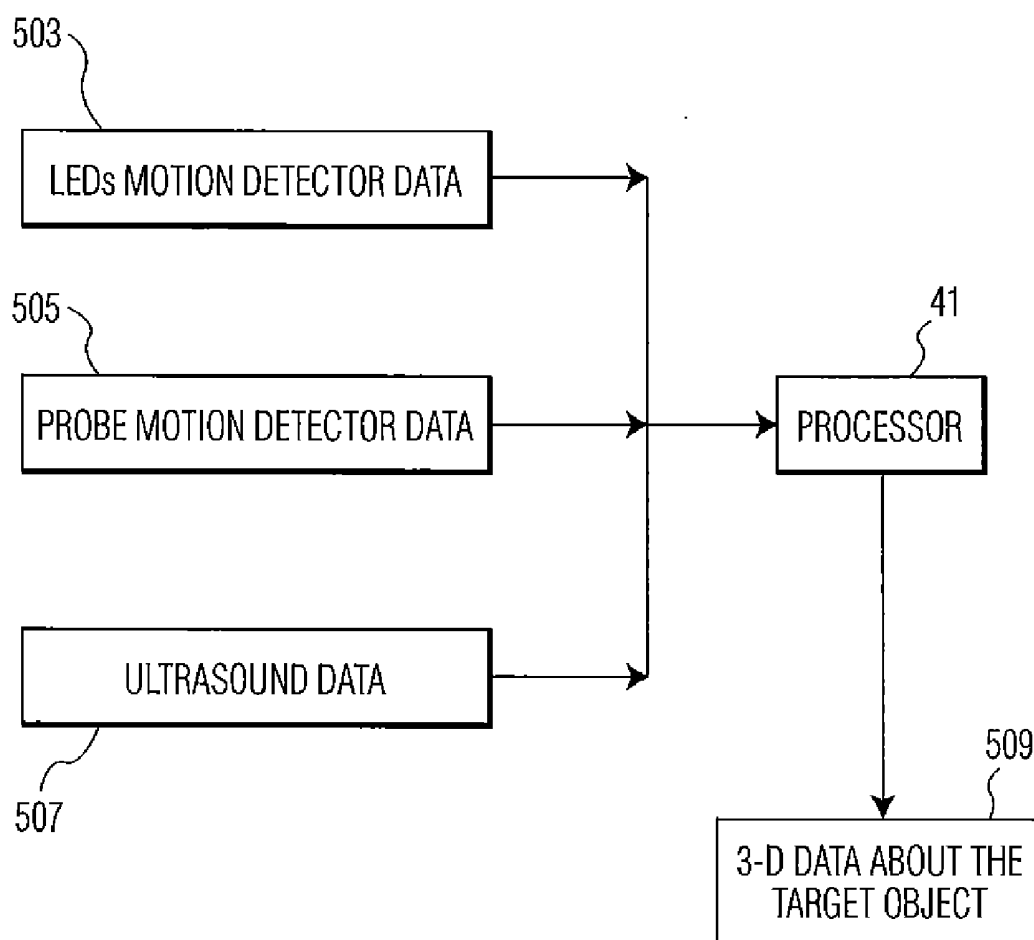

FIG. 15

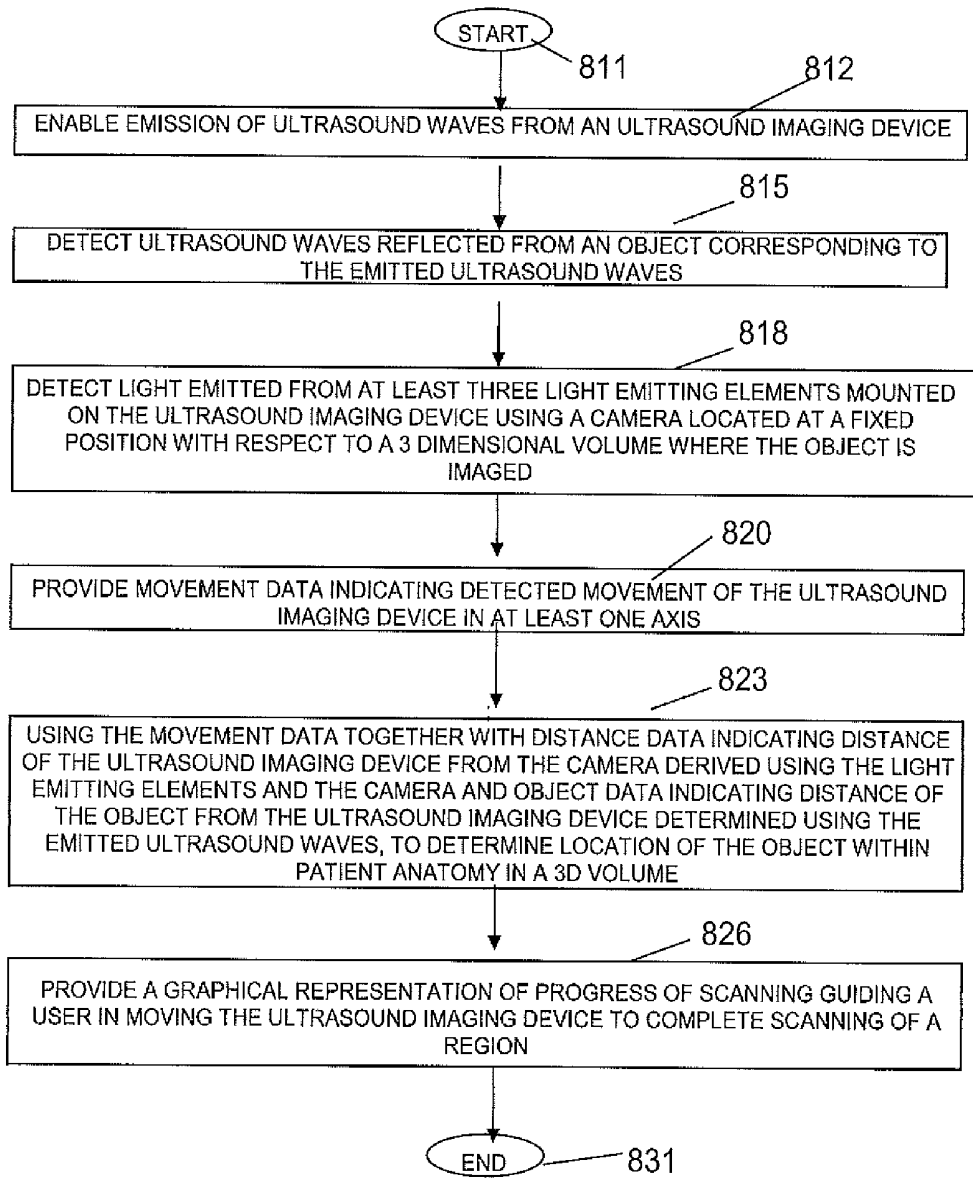

FIGURE 16

SYSTEM FOR LOCATING ANATOMICAL OBJECTS IN ULTRASOUND IMAGING

[0001] This is a non-provisional application of provisional application Ser. No. 61/394,793 filed Oct. 20, 2010, by G. Tripathi.

FIELD OF THE INVENTION

[0002] This invention concerns an ultrasound imaging device supporting determination of the location of an object scanned within a 3D volume by detecting movement of the object using the ultrasound imaging device and distance of the ultrasound imaging device from a camera derived using the camera and light emitting elements on the device.

BACKGROUND OF THE INVENTION

[0003] It is difficult to locate and observe anatomy of an object in a three dimensional (3D) volume through ultrasound waves. The problem becomes more significant when the object scanned is a body organ which reflects specific waves and the anatomy of the object needs to be determined by scanning all around it. A single view of imaging data populated using ultrasound gives a view of the object with reference to a position at which the technician performed the scan and placed the probe. The difficulty in locating and observing anatomy of an object in a 3D volume derives from the fact that a transmitter-detector assembly needs to be continuously moved (often in close proximity) of the object to obtain the reflection of the waves from its different surfaces. It is not possible to map the data captured from each view to one composite view of the object in the 3D space using the imaging system.

[0004] Known 3D ultrasound systems are used for fetal scanning. In 3D fetal scanning, instead of sound waves being directed straight down and reflected back, they are sent at different angles. The returning echoes are processed by a sophisticated computer program resulting in a reconstructed three dimensional volume image of a fetus surface or internal organs, in much the same way as a CT scan machine constructs a CT scan image from multiple X-rays. 3D ultrasound scans provide width, height and depth of images in much the same way as 3D movies but no movement is shown. Moreover the data obtained by 3D fetal scanning cannot be mapped for locating the fetal position inside a 3D volume. A system according to invention principles addresses these deficiencies and related problems.

SUMMARY OF THE INVENTION

[0005] A system captures ultrasound data from multiple different views and maps the data to one composite view of a 3D object under scan and advantageously distinguishes the target organ from its surrounding organs in response to transmitted ultrasound waves. An ultrasound imaging probe supports determination of the location of an object scanned within a 3D volume. A handheld movable ultrasound imaging device emits ultrasound waves and detects corresponding ultrasound waves reflected from an object. At least three light emitting elements are mounted on the ultrasound imaging device and are detectable by a camera located at a fixed position with respect to a 3D volume where the object is imaged. A motion detector provides data indicating detected movement of the ultrasound imaging device in at least one

axis. The data indicating detected movement is used together with distance data indicating distance of the ultrasound imaging device from the camera derived using the light emitting elements and the camera, to determine a location of the object scanned within a 3D volume using the ultrasound imaging device.

BRIEF DESCRIPTION OF THE DRAWING

[0006] FIG. 1 shows an ultrasound imaging system supporting determination of the location of an object scanned within a 3D volume, according to invention principles.

[0007] FIG. 2 shows a flowchart of a process used by an ultrasound imaging system supporting determination of the location of an object scanned within a 3D volume, according to invention principles.

[0008] FIG. 3 shows an initial step in determination of the location of an object scanned within a 3D volume in a system, according to invention principles.

[0009] FIG. 4 shows a reference frame used in determination of the location of an object scanned within a 3D volume in a system, according to invention principles.

[0010] FIG. 5 illustrates probe size calculation used in determination of the location of an object scanned within a 3D volume in a system, according to invention principles.

[0011] FIG. 6 illustrates calculation of vertical probe displacement used in determination of the location of an object scanned within a 3D volume in a system, according to invention principles.

[0012] FIG. 7 illustrates motion calculation used in determination of the location of an object scanned within a 3D volume in a system, according to invention principles.

[0013] FIG. 8 illustrates movement calculation of an ultrasound probe where orientation of the probe is unchanged, according to invention principles.

[0014] FIG. 9 illustrates movement calculation for correction for non-axial movement of an ultrasound (US) device where orientation of the device is changed, according to invention principles.

[0015] FIG. 10 illustrates calculating vertical movements of a hand held ultrasound device, according to invention principles.

[0016] FIG. 11 illustrates probe movement calculation used in determination of the location of an object scanned within a 3D volume in a system, according to invention principles.

[0017] FIG. 12 illustrates movement calculation for correction for non-axial movement of the ultrasound (US) device using both detected LED triangle location data and motion detector data, according to invention principles.

[0018] FIG. 13 illustrates a vector calculation in determination of the location of an object scanned within a 3D volume in a system, according to invention principles.

[0019] FIG. 14 shows a display image guiding a user in ultrasound scanning a region of interest (ROI) according to invention principles.

[0020] FIG. 15 shows data flow used in determination of the location of an object scanned within a 3D volume in a system, according to invention principles.

[0021] FIG. 16 shows a flowchart of a process used by an ultrasound imaging system supporting determination of the location of an object scanned within a 3D volume, according to invention principles.

DETAILED DESCRIPTION OF THE INVENTION

[0022] A system captures ultrasound image data from multiple different views and maps the data to one composite view

of a three dimensional (3D) object under scan. This advantageously distinguishes a target organ from surrounding organs in response to the ultrasound waves sent. During a contrast enhanced ultrasound scan the system facilitates understanding anatomical and physiological behavior of the organs and object. The system uses an ultrasound device which can be hand held by a technician or physician and moved over a patient body for scanning.

[0023] FIG. 1 shows ultrasound imaging system 10 supporting determination of the location of an object scanned within a 3D volume. System 10 advantageously uses ultrasound probe 13 having, in one embodiment, three distinguishable light sources such as LEDs 15 on top of the ultrasound probe and motion detector 19 on the bottom of the probe. LEDs 15 are located at points A, B and C making an equilateral triangle, for example. The LEDs at points A, B and C are fitted in a position on probe 13 so that distance measured from ultrasound probe 13 to an anatomical object within a patient is mapped to the plane represented by these points and the points facilitate determining location and orientation of probe 13 in reference volume 20. Camera 17 with a known focal length is fitted above a patient support table. Camera 17 continuously captures images of LEDs 15 and the images are processed by computer system 33 to locate the movement of points A, B, C 15 and therefore of ultrasound probe 13. Movement detector (e.g., laser) 19 is attached to a point on probe 13 which comes in contact with patient anatomy. In one embodiment, detector 19 is similar to a laser commonly found in a mouse and which detects movement relative to a surface in close proximity to a mouse.

[0024] Handheld movable ultrasound imaging device 13 emits ultrasound waves and detects corresponding ultrasound waves reflected from an object. At least three light emitting elements 15 are mounted on the ultrasound imaging device. Camera 17 is located at a fixed position with respect to 3D (three dimensional) volume 20 where the object is imaged and detects light from the at least three light emitting elements 15 for tracking movement of the light emitting elements. Motion detector 19 provides data indicating detected movement of ultrasound imaging device 13 in at least one axis. At least one processor 41 in computer 33 processes the data indicating detected movement and distance data indicating distance of ultrasound imaging device 13 from camera 17 derived using light emitting elements 15 and camera 17, to determine a location of the object scanned within 3D volume 20 using ultrasound imaging device 13. FIG. 4 shows a reference frame and 3D coordinate system used in determination of the location of an object scanned within 3D volume 20. Display 56 presents a graphical user interface (GUI) for operation of system 10 and presents ultrasound images and associated data and measurements for viewing by a user.

[0025] FIG. 2 shows a flowchart of a process used by an ultrasound imaging system supporting determination of the location of an object scanned within a 3D volume. In step 205 following the start at step 203, in order to initialize system 10 (FIG. 1), ultrasound probe 13 is placed at a known distance from camera 17 and processor 41 determines an accurate size of a triangle formed by LEDs A, B and C 15. FIG. 5 illustrates probe size calculation used in determination of the location of an object scanned within a 3D volume in a system. Processor 41 determines size of triangle $A_0B_0C_0$ from image data acquired by camera 17 in response to probe 13 being brought to known distance Z_0 230 from camera 17. The location of the target object in the 3d reference volume is performed by

determining a reference position of the ultrasound device 13. A user brings LEDs A, B and C 15, mounted on top of the ultrasound device, to a point which is at a known distance from camera 17. Processor 41 calculates size of triangle ABC drawn on the ultrasound probe using,

$$\frac{\text{Focal Length} \times \text{Object size}}{\text{Lens-to-object distance}} = \text{Image Size}$$

[0026] In step 207, processor 41 determines a distance moved by probe 13 D_0 , in response to probe 13 being brought in contact with patient anatomy. FIG. 6 illustrates calculation of vertical probe displacement used in determination of the location of an object scanned within a 3D volume in system 10. Processor 41 determines the magnification of $A_1B_1C_1$ with respect to $A_0B_0C_0$ using image data acquired by camera 17. LED triangle $A_1B_1C_1$ is shown in an image acquired by camera 17 at an unknown distance Z_1 233 from the origin at camera 17, when probe 13 touches patient point P_1 (at time $t=0$). Processor 41 uses a determined magnification factor to derive displacement Z_1 233 of probe 13 along the Z-axis upon the probe touching patient P_1 . Hence processor 41 determines vertical vector $V_{ver}=(0, 0, Z_1)$. FIG. 3 shows determination of vertical distance of each LED at time t using the previously described image size function, AB is actual length of side AB of the triangle as calculated, $AtBt$ is the length of side AB of triangle as seen at time t from vertical distance Dt. The location of centre of the triangle ABC at any point t is calculated as D_0 . FIG. 10 illustrates calculating vertical movements of hand held ultrasound device 13. Handheld ultrasound device 13 is moved along the axis of the lens, until it touches the patient body at the point where the examination is to be done. System 10 continues to capture images of LEDs and at any time t, from the images obtains a new triangle $A_1B_1C_1$.

[0027] In step 210 (FIG. 2), processor 41 determines a distance delta (dt) moved by a center point (a vertex of the 3 medians of a triangle) between LED triangle positions $A_1B_1C_1$ and $A_2B_2C_2$ of probe 13 as determined by motion detector 19 as illustrated in FIG. 11. Specifically, FIG. 11 illustrates probe 13 movement of distance $D_{pat_{1-2}}$ 236 in the camera axis as the probe is moved across patient anatomy between times t_1 and t_2 (of time difference dt). FIG. 7 similarly shows movement of the LED triangle center point between LED triangle positions $A_1B_1C_1$ and $A_tB_tC_t$ of probe 13 as determined by motion detector 19. LEDs form triangle $A_tB_tC_t$ at a point in time t at distance Z_t from the origin. The magnification in image of $A_tB_tC_t$ with respect to the triangle $A_0B_0C_0$ determined at the calibration position (previously shown in FIG. 6) gives the displacement of probe Z_t along the Z-axis. The shift of the center point of the triangle along the x-y plane, i.e. (X_t, Y_t) is determined by the shift in coordinates of center point at time t. Hence the location of the triangle center point at time t in reference volume 20 is determined by the vector $V_t=(X_t, Y_t, Z_t)$

[0028] In step 213, processor 41 calculates a distance vector of the LED triangle center point at time t as,

$$D_t=D_{t-1}+\text{delta}(\text{dt})$$

Where delta (dt) is distance moved by the center point at time t from initial distance D_{t-1} at prior time t_{-1} .

[0029] FIG. 8 illustrates movement calculation of probe 13 where orientation of probe 13 is unchanged. Distance (d_{1-2} 239) moved by the probe from time t_1 to t_2 is determined by

subtraction of vectors representing the LED triangle $A_1B_1C_1$ and $A_tB_tC_t$ center points at these times,

$$d_{1-2} = ((X_1 - X_2)^2 + (Y_1 - Y_2)^2 + (Z_1 - Z_2)^2)^{1/2}$$

[0030] FIG. 9 illustrates movement calculation for correction for non-axial movement of the ultrasound (US) device 13 where orientation of probe 13 is changed. Processor 41 determines how far probe 13 is moved from the line of sight axis through camera 17 by position of the three LED triangle ABC points along with the movement data captured by the movement detector 19. Distance d_{1-2} 242 changes when the orientation of LED triangle ABC is changed as probe 13 is moved on a patient. This is because upon change of orientation, points A, B and C are not lying on a plane perpendicular to camera 17 line of sight axis. Processor 41 compares distance d_{1-2} 242 as measured in FIG. 8 with distance d_{1-2} 242 determined using motion detector 19 fitted at the base of probe 13. If there is a difference, processor 41 corrects distance d_{1-2} 242 with movement data determined using motion detector 19. Specifically, processor 41 corrects displacement measurement due to change in orientation of probe 13. For example, in determination of location of probe 13 at time $t=1$, if a 3D coordinate vector representing the center point of triangle ABC is given by, $V_1 = (0 \text{ cm}, 0 \text{ cm}, 10 \text{ cm})$ and motion detector 19 detects distance moved on a patient at time $t=1$ as, 2 cm along x and 1 cm along y axis, processor 41 corrects the resultant location of point at time $t=1$ to be $V_t = (2 \text{ cm}, 1 \text{ cm}, 10 \text{ cm})$.

[0031] FIG. 12 illustrates movement calculation for correction for non-axial movement of the ultrasound (US) device 13 using both LED triangle and motion detector 19 data. Processor 41 determines vertical distance moved by probe 13 (Dver1-2 303) using a right angle triangle estimation comprising Dver1-2 303, Dv1-2 306 and Dpat1-2 309, where Dv1-2 306 comprises distance moved by the center point of triangle ABC as calculated in step 213 and Dpat1-2 309 comprises distance moved by probe 13 on the patient as captured by motion detector 19. In the calculation, for a short time where $t_2 - t_1$ tends towards zero, Dpat1-2 comprises a straight line. Hence the vertical movement of the ultrasound assembly is calculated by processor 41 using right angle triangle properties.

[0032] In step 216, processor 41 performs a vector calculation to determine location of an object inside reference volume 20 (FIG. 1). In response to three dimensional location of the LED triangle points of probe 13 in steps 205-213, the location of an anatomical object in volume 20 is determined. FIG. 13 illustrates a vector calculation in determination of the location of an object scanned within 3D volume 20. Specifically, processor 41 calculates a resultant distance vector (DusRefVol) of an object in volume 20 as,

$$\text{Vector}(\text{DusRefVol}) = \text{Vector}(\text{Dus}_{a-b-c}) + \text{Vector}(\text{Dvera-b-c})$$

Where,

[0033] Dus_{a-b-c} = a distance vector calculated by ultrasound system 10 (FIG. 1) and probe 13 of a target object (using reflected ultrasound waves) within patient anatomy and volume 20 with respect to the center point of triangle ABC as captured by the ultrasound probe 13 with respect to the plane on which points ABC lie and

[0034] Dvera-b-c = distance vector of the center point of triangle ABC with respect to 3D volume 20 as calculated in

step 213 (FIG. 2). The vertical component of vector DusRefVol provides a distance of each point of a target anatomical object comprising vertical locations of each pixel from a plane where camera 17 is placed.

[0035] In step 219, processor 41 determines whether an imaging slice region within reference volume 20 (FIG. 1) has been imaged and processed. Processor 41 processes data indicating movement of LED triangle ABC points and determines the section of a volume 20 slice scanned by ultrasound device 13 at a time t. This information assists a user in scanning a targeted portion of a slice of 3D volume 20 and directs a user to scan in a particular direction and also to stop scanning if probe 13 is being moved out of volume 20. FIG. 14 shows a display image guiding a user in ultrasound scanning a ROI. Processor 41 uses the calculated distance and vector data in determining that region 405 of slice 403 is already scanned and region 407 is yet to be scanned. Processor 41 provides a graphical representation of progress of scanning showing slice 403 and regions 405 and 407 for use in guiding a user in moving probe 13 to complete scanning of slice 403. The process of FIG. 2 terminates at step 221.

[0036] FIG. 15 shows data flow in determination of the location of an object scanned within 3D volume 20 in system 10 (FIG. 1). Processor 41 acquires ultrasound imaging data 507 from handheld movable ultrasound imaging device 13 indicating distance of an anatomical object from probe 13, data 505 indicating detected movement of ultrasound imaging device 13 in at least one axis from motion detector 19 and movement data 503 derived using camera 17 indicating movement of at least three light emitting elements mounted on ultrasound imaging device 13. Processor 41 processes acquired data, 503, 505 and 507 to calculate a resultant distance vector 509 of an object in volume 20 and provide a graphical representation of progress of scanning showing a slice for use in guiding a user in moving probe 13 to complete scanning of the slice.

[0037] Increasing the size of LED triangle ABC on ultrasound assembly probe 13 improves accuracy of detection of probe 13 movement. Also scanning is performed in such a way that the orientation of triangle ABC is visible and accurately detected by camera 17. System 10 advantageously integrates data captured through ultrasound scanning performed in close proximity of a target anatomical object at different time instances and associates that data with a 3D volume where the target object is located. The system supports real time observation and user performance of an imaging scan and detects movement of probe 13 in a 3D volume and makes measurement based on reflective rays compatible with other radiation imaging systems (transmitting or absorption radiations).

[0038] In another embodiment, instead of using LEDs, an ultrasound assembly is mounted with radio frequency transmitter/receiver, to detect movements to an acceptable accuracy. Movement of points A, B and C on the probe may also be detected by placing a laser emitter/detector that can detect the movement of reflecting points on the patient. An additional LED may be placed at the vertex of triangle ABC, to help in identifying the orientation of the assembly if the ultrasound is held at a position where the plane ABC is not perpendicular to axis of the camera lens.

[0039] FIG. 16 shows a flowchart of a process used by ultrasound imaging system 10 (FIG. 1) supporting determination of the location of an object scanned within 3D volume 20. In step 812 following the start at step 811, ultrasound

imaging probe **13** enables emission of ultrasound waves. In step **815**, probe **13** detects ultrasound waves reflected from an object corresponding to the emitted ultrasound waves. In step **818**, camera **17** located at a fixed position with respect to three dimensional volume **20** where the object is imaged, detects light emitted from at least three light emitting elements **15** mounted on ultrasound imaging device **13**. Camera **17** continuously periodically acquires images of the light emitting elements to track movement of the light emitting elements. Light emitting elements **15** lie in a plane having a known orientation with respect to direction of ultrasound wave emission by ultrasound imaging devices **15**. Light emitting elements **15** are individually distinguishable from each other by image data derived by the camera and comprise at least one of, (a) LEDs and (b) light reflective elements. Movement detector **19** provides movement data indicating detected movement of ultrasound imaging device **13** in at least one axis. The detected movement of the ultrasound imaging device is used to correct for movement of the ultrasound imaging device away from an axis parallel to direction of ultrasound wave emission.

[0040] Processor **41** in step **823** uses the movement data together with distance data indicating distance of ultrasound imaging device **13** from camera **17** derived using light emitting elements **15** and camera **17** and object data indicating distance of the object from ultrasound imaging device **13** determined using the emitted ultrasound waves, to determine a location of the object scanned within patient anatomy in 3D volume **20** with respect to camera **17** using ultrasound imaging device **13**. Processor **41** determines the distance data indicating distance of the ultrasound imaging device from the camera by geometrically processing image data acquired by the camera identifying relative location of the individual elements of the light emitting elements. In step **826**, processor **41** also uses the movement data, distance data and object data to provide a graphical representation of progress of scanning guiding a user in moving the ultrasound imaging device to complete scanning of a region (e.g., a slice.). The process of FIG. **16** terminates at step **831**.

[0041] A processor as used herein is a device for executing machine-readable instructions stored on a computer readable medium, for performing tasks and may comprise any one or combination of, hardware and firmware. A processor may also comprise memory storing machine-readable instructions executable for performing tasks. A processor acts upon information by manipulating, analyzing, modifying, converting or transmitting information for use by an executable procedure or an information device, and/or by routing the information to an output device. A processor may use or comprise the capabilities of a computer, controller or microprocessor, for example, and is conditioned using executable instructions to perform special purpose functions not performed by a general purpose computer. A processor may be coupled (electrically and/or as comprising executable components) with any other processor enabling interaction and/or communication therebetween. A user interface processor or generator is a known element comprising electronic circuitry or software or a combination of both for generating display images or portions thereof. A user interface comprises one or more display images enabling user interaction with a processor or other device.

[0042] An executable application, as used herein, comprises code or machine readable instructions for conditioning the processor to implement predetermined functions, such as

those of an operating system, a context data acquisition system or other information processing system, for example, in response to user command or input. An executable procedure is a segment of code or machine readable instruction, subroutine, or other distinct section of code or portion of an executable application for performing one or more particular processes. These processes may include receiving input data and/or parameters, performing operations on received input data and/or performing functions in response to received input parameters, and providing resulting output data and/or parameters. A user interface (UI), as used herein, comprises one or more display images, generated by a user interface processor and enabling user interaction with a processor or other device and associated data acquisition and processing functions.

[0043] The UI also includes an executable procedure or executable application. The executable procedure or executable application conditions the user interface processor to generate signals representing the UI display images. These signals are supplied to a display device which displays the image for viewing by the user. The executable procedure or executable application further receives signals from user input devices, such as a keyboard, mouth, light pen, touch screen or any other means allowing a user to provide data to a processor. The processor, under control of an executable procedure or executable application, manipulates the UI display images in response to signals received from the input devices. In this way, the user interacts with the display image using the input devices, enabling user interaction with the processor or other device. The functions and process steps herein may be performed automatically or wholly or partially in response to user command. An activity (including a step) performed automatically is performed in response to executable instruction or device operation without user direct initiation of the activity.

[0044] The system and processes of FIGS. **1-16** are not exclusive. Other systems, processes and menus may be derived in accordance with the principles of the invention to accomplish the same objectives. Although this invention has been described with reference to particular embodiments, it is to be understood that the embodiments and variations shown and described herein are for illustration purposes only. Modifications to the current design may be implemented by those skilled in the art, without departing from the scope of the invention. An ultrasound imaging system determines the location of an object scanned within a 3D volume by capturing ultrasound image data from multiple different views and maps the data to one composite view of a three dimensional (3D) object under scan. Further, the processes and applications may, in alternative embodiments, be located on one or more (e.g., distributed) processing devices on a network linking the units of FIG. **1**. Any of the functions and steps provided in FIGS. **1-16** may be implemented in hardware, software or a combination of both.

What is claimed is:

1. An ultrasound imaging probe supporting determination of the location of an object scanned within a 3D volume, comprising:

- a handheld movable ultrasound imaging device for emitting ultrasound waves and detecting corresponding ultrasound waves reflected from an object;
- at least three light emitting elements mounted on said ultrasound imaging device and being detectable by a camera

- located at a fixed position with respect to a 3 dimensional volume where said object is imaged; and
 a motion detector for providing data indicating detected movement of said ultrasound imaging device in at least one axis, said data indicating detected movement being used together with distance data indicating distance of said ultrasound imaging device from said camera derived using said light emitting elements and said camera, to determine a location of said object scanned within a 3D volume using said ultrasound imaging device.
- 2.** A system according to claim 1, wherein said light emitting elements be in a plane having a known orientation with respect to direction of ultrasound wave emission by said ultrasound imaging device.
- 3.** A system according to claim 1, wherein said light emitting elements are individually distinguishable from each other by image data derived by said camera and comprise at least one of, (a) LEDs and (b) light reflective elements.
- 4.** A system according to claim 1, wherein said detected movement of said ultrasound imaging device is used to correct for movement of said ultrasound imaging device away from an axis parallel to direction of ultrasound wave emission.
- 5.** An ultrasound imaging system supporting determination of the location of an object scanned within a 3D volume, comprising:
 a handheld movable ultrasound imaging device for emitting ultrasound waves and detecting corresponding ultrasound waves reflected from an object;
 at least three light emitting elements mounted on said ultrasound imaging device;
 a camera located at a fixed position with respect to a 3 dimensional volume where said object is imaged, for detecting light from said at least three light emitting elements for tracking movement of said light emitting elements;
 a motion detector for providing data indicating detected movement of said ultrasound imaging device in at least one axis; and
 at least one processor for processing
 said data indicating detected movement and
 distance data indicating distance of said ultrasound imaging device from said camera derived using said light emitting elements and said camera, to determine a location of said object scanned within a 3D volume using said ultrasound imaging device.
- 6.** A system according to claim 5, wherein said at least one processor determines said distance data indicating distance of said ultrasound imaging device from said camera by geometrically processing of image data acquired by said camera identifying relative location of said individual elements of said light emitting elements.
- 7.** A system according to claim 5, wherein said camera continuously acquires images of said light emitting elements to track movement of said light emitting elements.
- 8.** A system according to claim 5, wherein said detected movement of said ultrasound imaging device is used to correct for movement of said ultrasound imaging device away from an axis parallel to direction of ultrasound wave emission.
- 9.** A system according to claim 5, wherein said at least one processor processes
 said data indicating detected movement,
 said distance data indicating distance of said ultrasound imaging device from said camera and
 object data indicating distance of said object from said ultrasound imaging device determined using the emitted ultrasound waves, to determine location of said object within patient anatomy in a 3D volume.
- 10.** A system according to claim 5, wherein said at least one processor processes
 said data indicating detected movement and
 said distance data indicating distance of said ultrasound imaging device from said camera, to provide a graphical representation of progress of scanning guiding a user in moving said ultrasound imaging device to complete scanning of a region.
- 11.** A system according to claim 10, wherein said at least one processor processes object data indicating distance of said object from said ultrasound imaging device determined using the emitted ultrasound waves, to determine location of said object within patient anatomy in a 3D volume.
- 12.** A system according to claim 10, wherein said at least one processor provides a graphical representation of progress of scanning showing a region for use in guiding a user in moving said ultrasound imaging device to complete scanning of the region.
- 13.** A system according to claim 12, wherein said region comprises a slice.
- 14.** A method for ultrasound imaging and determination of location of an object scanned within a 3D volume, comprising:
 enabling emission of ultrasound waves from an ultrasound imaging device;
 detecting ultrasound waves reflected from an object corresponding to the emitted ultrasound waves;
 detecting light emitted from at least three light emitting elements mounted on said ultrasound imaging device using a camera located at a fixed position with respect to a 3 dimensional volume where said object is imaged; and
 providing movement data indicating detected movement of said ultrasound imaging device in at least one axis; and
 using the movement data together with distance data indicating distance of said ultrasound imaging device from said camera derived using said light emitting elements and said camera, to determine a location of said object scanned within a 3D volume using said ultrasound imaging device.
- 15.** A method according to claim 14, including the activity of
 using said data indicating detected movement, said distance data indicating distance of said ultrasound imaging device from said camera and object data indicating distance of said object from said ultrasound imaging device determined using the emitted ultrasound waves, to determine location of said object within patient anatomy in a 3D volume.
- 16.** A system according to claim 14, including the activity of

using said data indicating detected movement and said distance data indicating distance of said ultrasound imaging device from said camera, to provide a graphical representation of progress of scanning guiding a user in

moving said ultrasound imaging device to complete scanning of a region.

* * * * *

专利名称(译)	超声成像中定位对象的定位系统		
公开(公告)号	US20120101388A1	公开(公告)日	2012-04-26
申请号	US13/153726	申请日	2011-06-06
[标]申请(专利权)人(译)	TRIPATHI高拉夫		
申请(专利权)人(译)	TRIPATHI高拉夫		
当前申请(专利权)人(译)	西门子医疗GMBH		
[标]发明人	TRIPATHI GAURAV		
发明人	TRIPATHI, GAURAV		
IPC分类号	A61B8/00		
CPC分类号	A61B8/085 A61B8/4263 A61B8/4254		
优先权	61/394793 2010-10-20 US		
其他公开文献	US9113817		
外部链接	Espacenet	USPTO	

摘要(译)

超声成像探头支持确定在3D体积内扫描的物体的位置。手持式可移动超声成像设备发射超声波并检测从物体反射的相应超声波。至少三个发光元件安装在超声成像设备上，并且可以由位于相对于对象被成像的3D体积的固定位置的相机检测。运动检测器提供指示检测到的超声成像装置在至少一个轴上的运动的数据。指示检测到的移动的数据与指示超声成像设备相对于使用发光元件和相机导出的相机的距离的距离数据一起使用，以使用超声成像设备确定在3D体积内扫描的对象的位置。

