



(19) **United States**

(12) **Patent Application Publication**
Lashinski et al.

(10) **Pub. No.: US 2017/0086974 A1**
(43) **Pub. Date: Mar. 30, 2017**

(54) **METHODS FOR DELIVERY OF HEART VALVE DEVICES USING INTRAVASCULAR ULTRASOUND IMAGING**

A61B 8/12 (2006.01)
A61B 17/064 (2006.01)

(71) Applicant: **MILLIPEDE, INC.**, Santa Rosa, CA (US)

(52) **U.S. Cl.**
CPC *A61F 2/2427* (2013.01); *A61F 2/2412* (2013.01); *A61F 2/2466* (2013.01); *A61B 17/064* (2013.01); *A61B 8/0833* (2013.01); *A61B 8/12* (2013.01); *A61B 2017/0649* (2013.01); *A61B 2017/0647* (2013.01)

(72) Inventors: **Randall Lashinski**, Windsor, CA (US); **Kristian Kristoffersen**, Redding, CA (US); **Matthew Rust**, Windsor, CA (US); **Richard Glenn**, Santa Rosa, CA (US); **Michael Lee**, Santa Rosa, CA (US); **Patrick Macaulay**, Windsor, CA (US)

(57) **ABSTRACT**

(21) Appl. No.: **15/280,004**

(22) Filed: **Sep. 29, 2016**

Related U.S. Application Data

(60) Provisional application No. 62/234,592, filed on Sep. 29, 2015.

Publication Classification

(51) **Int. Cl.**
A61F 2/24 (2006.01)
A61B 8/08 (2006.01)

Methods related to delivery of various heart valve implants are described. The implant may be delivered using an ultrasound imaging delivery system. The ultrasound imaging delivery system may be used to deliver a variety of different devices, including mitral valve reshaping devices, mitral valve replacement valves, and others. A deployment catheter carrying an implant having a tissue anchor is advanced to a deployment site in a heart. An imaging element is positioned adjacent the implant and a relationship between the tissue anchor and an anatomical landmark in the heart is visualized. The implant is then attached by driving the tissue anchor into tissue in the heart.

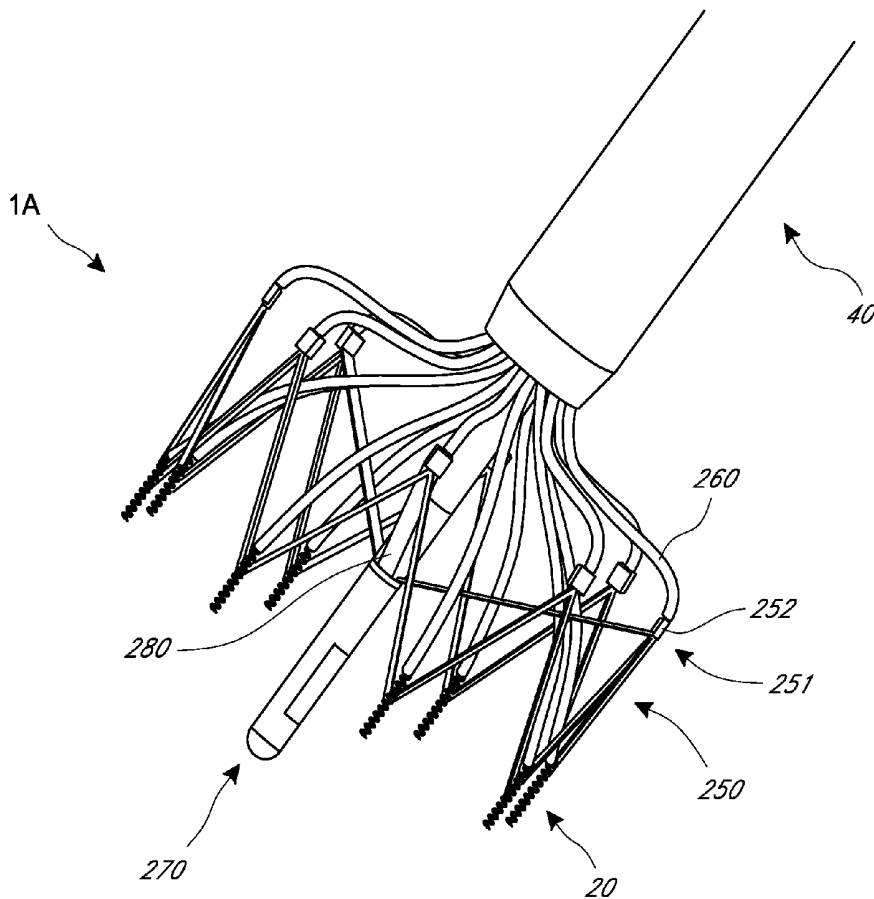

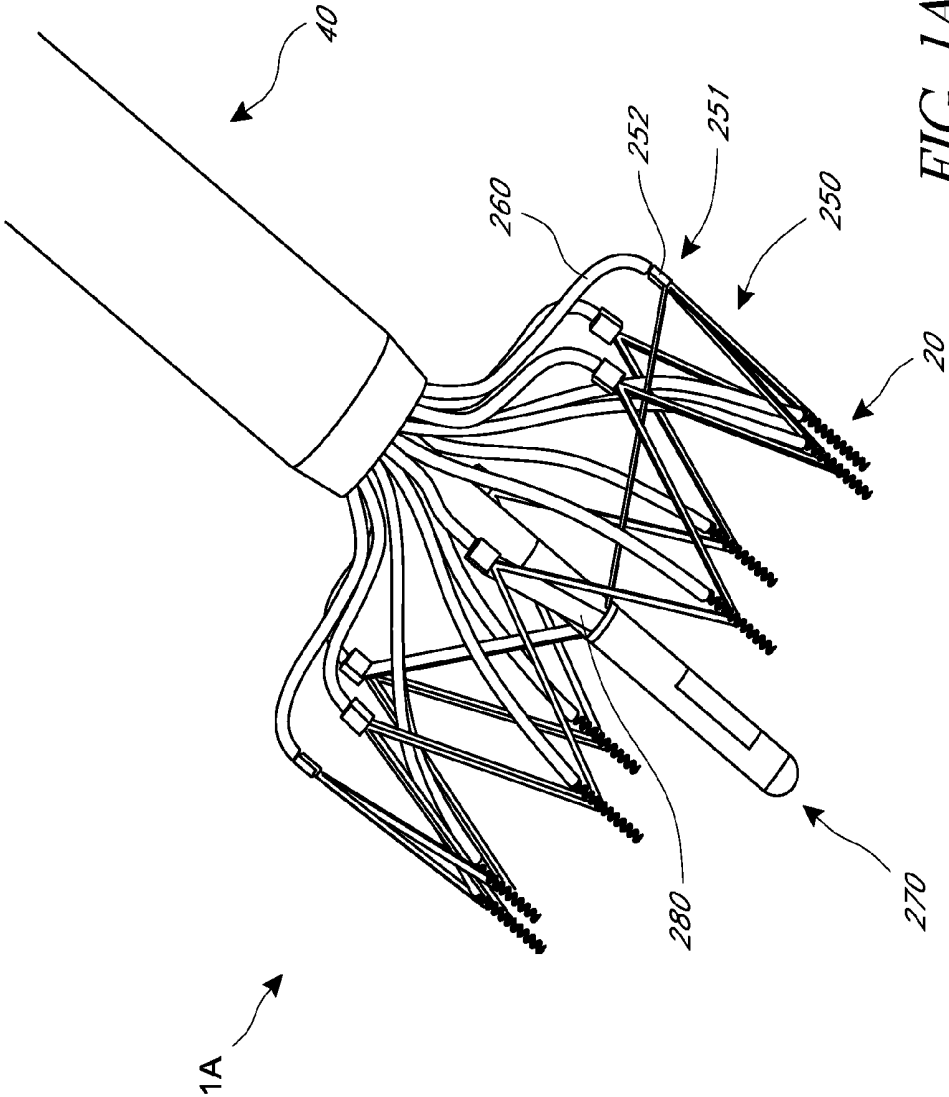

FIG. 1A

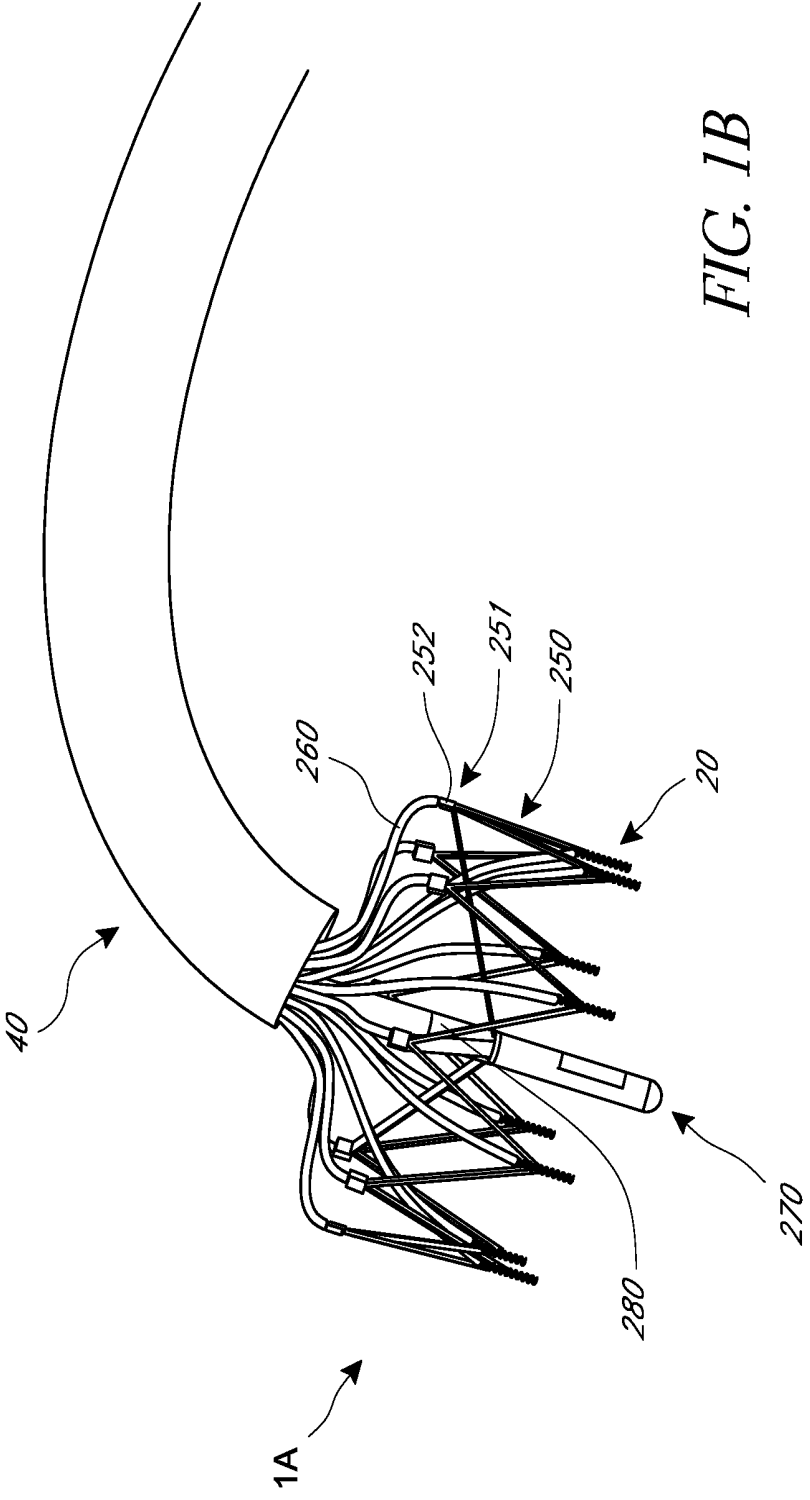

FIG. 1B

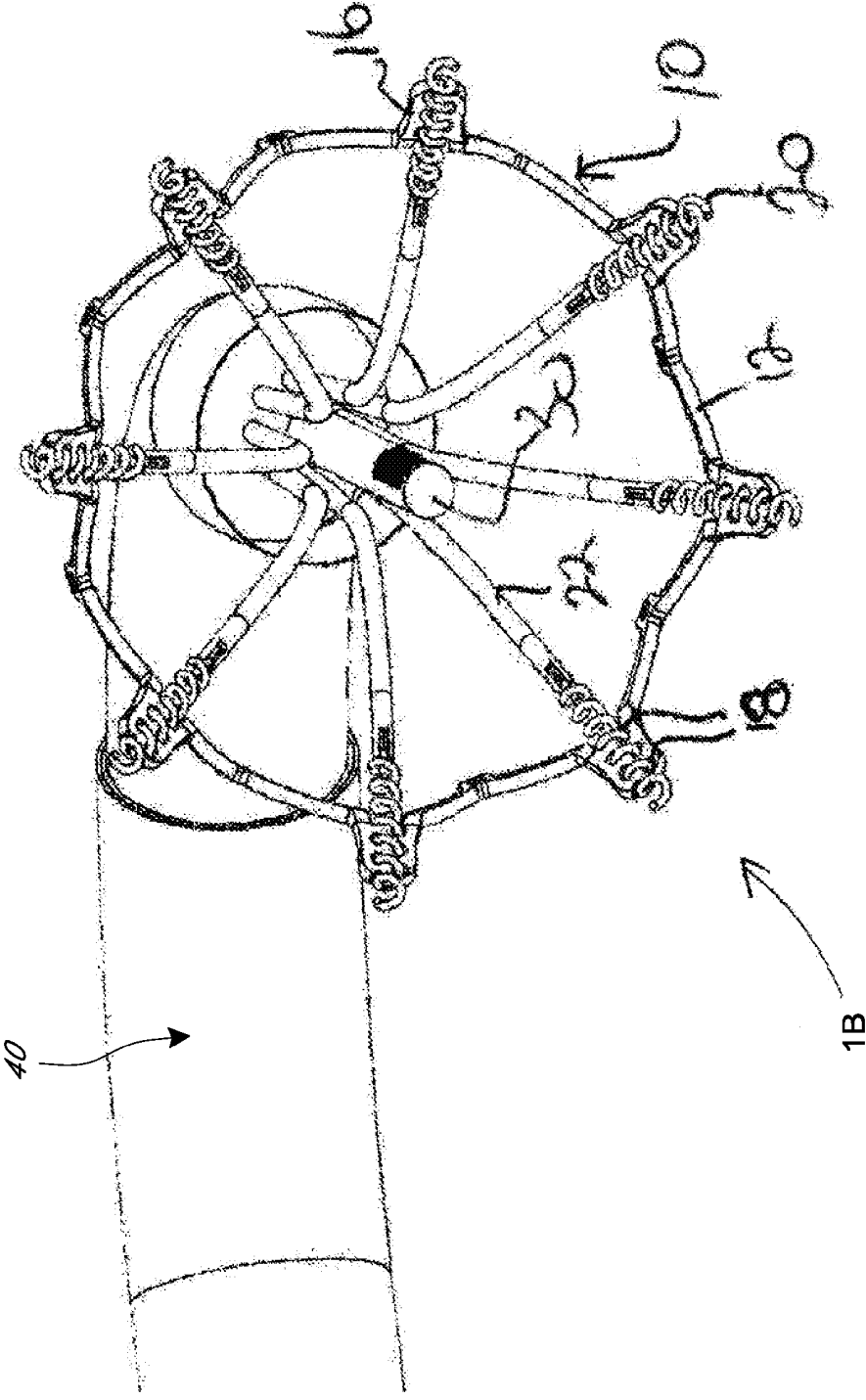
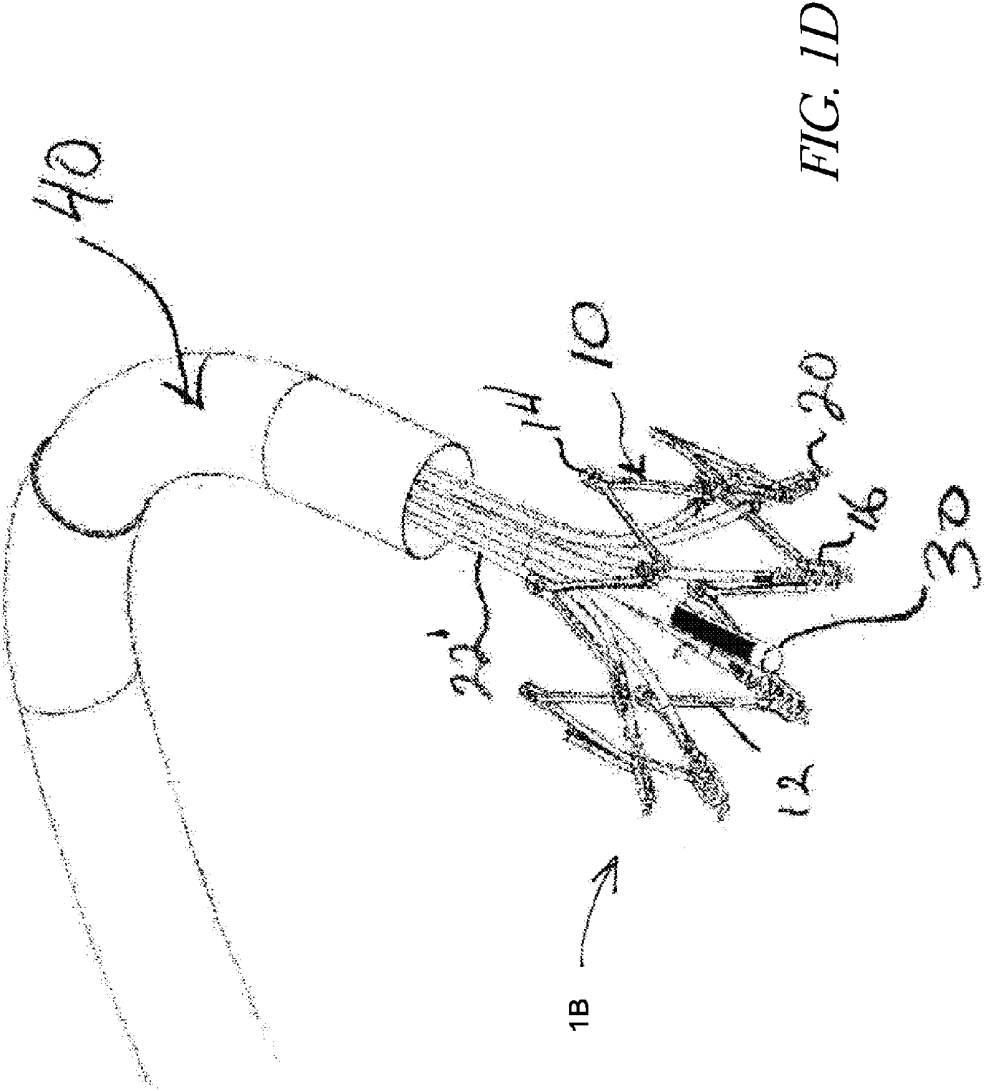

FIG. 1C



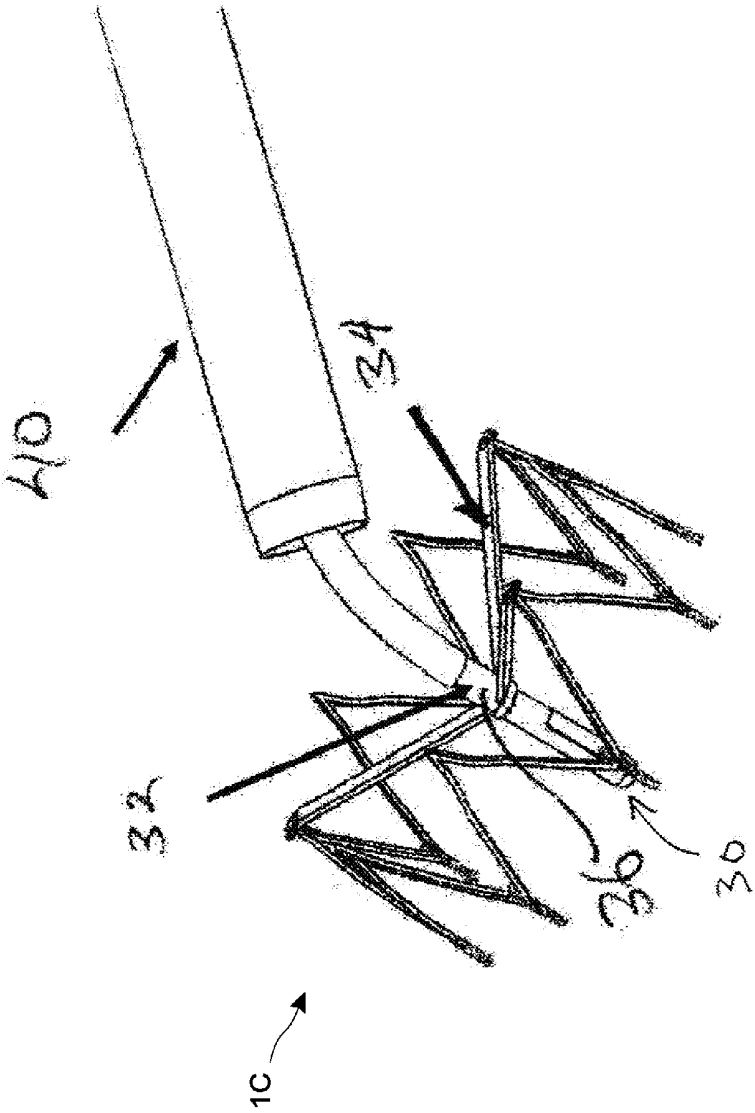

FIG. 1E

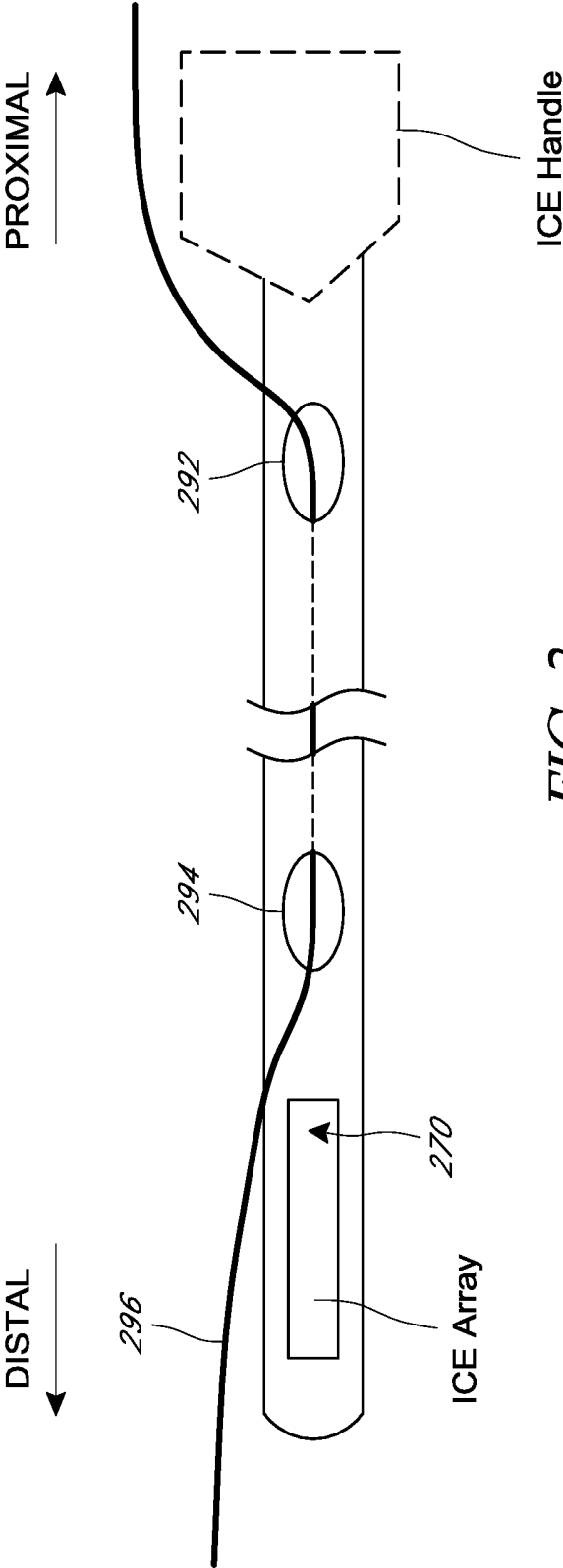

FIG. 2

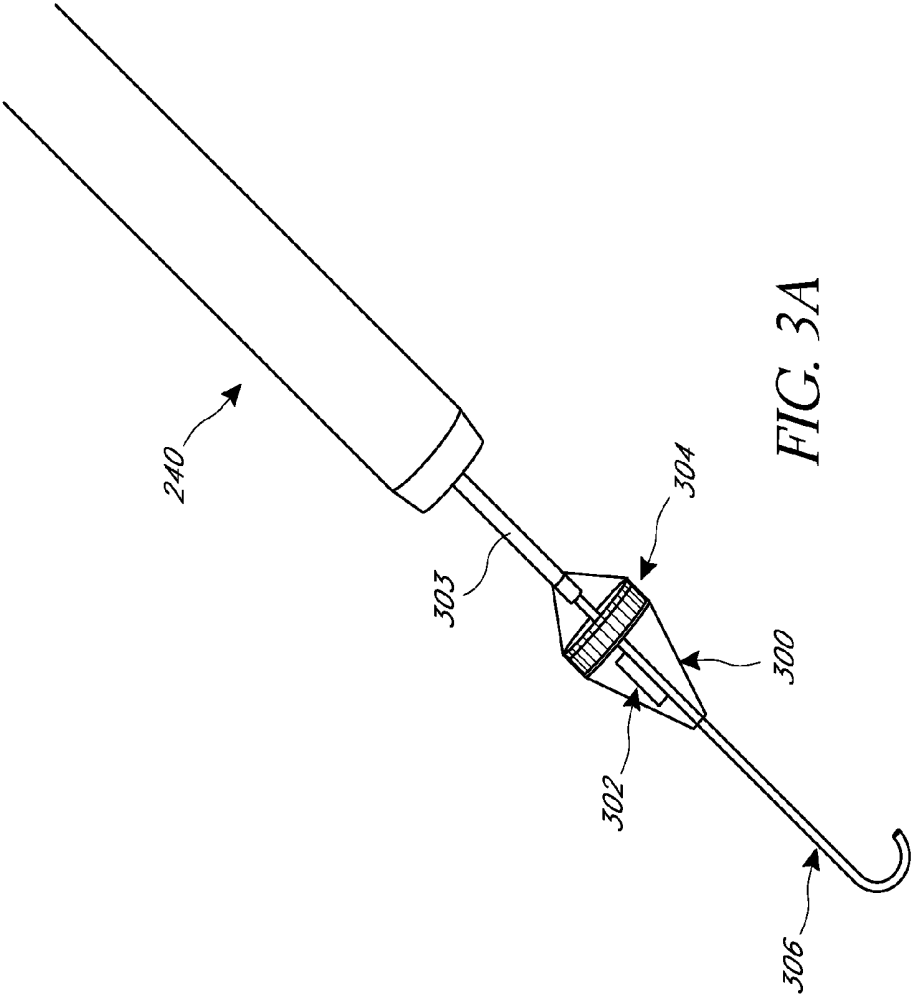

FIG. 3A

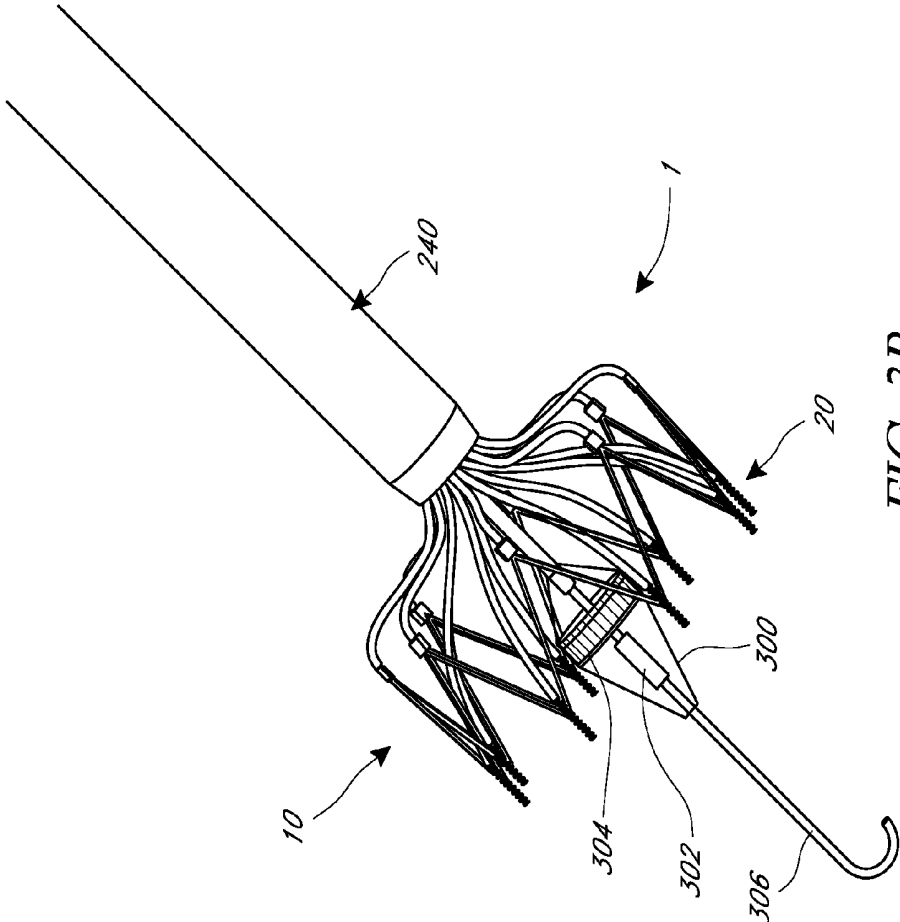

FIG. 3B

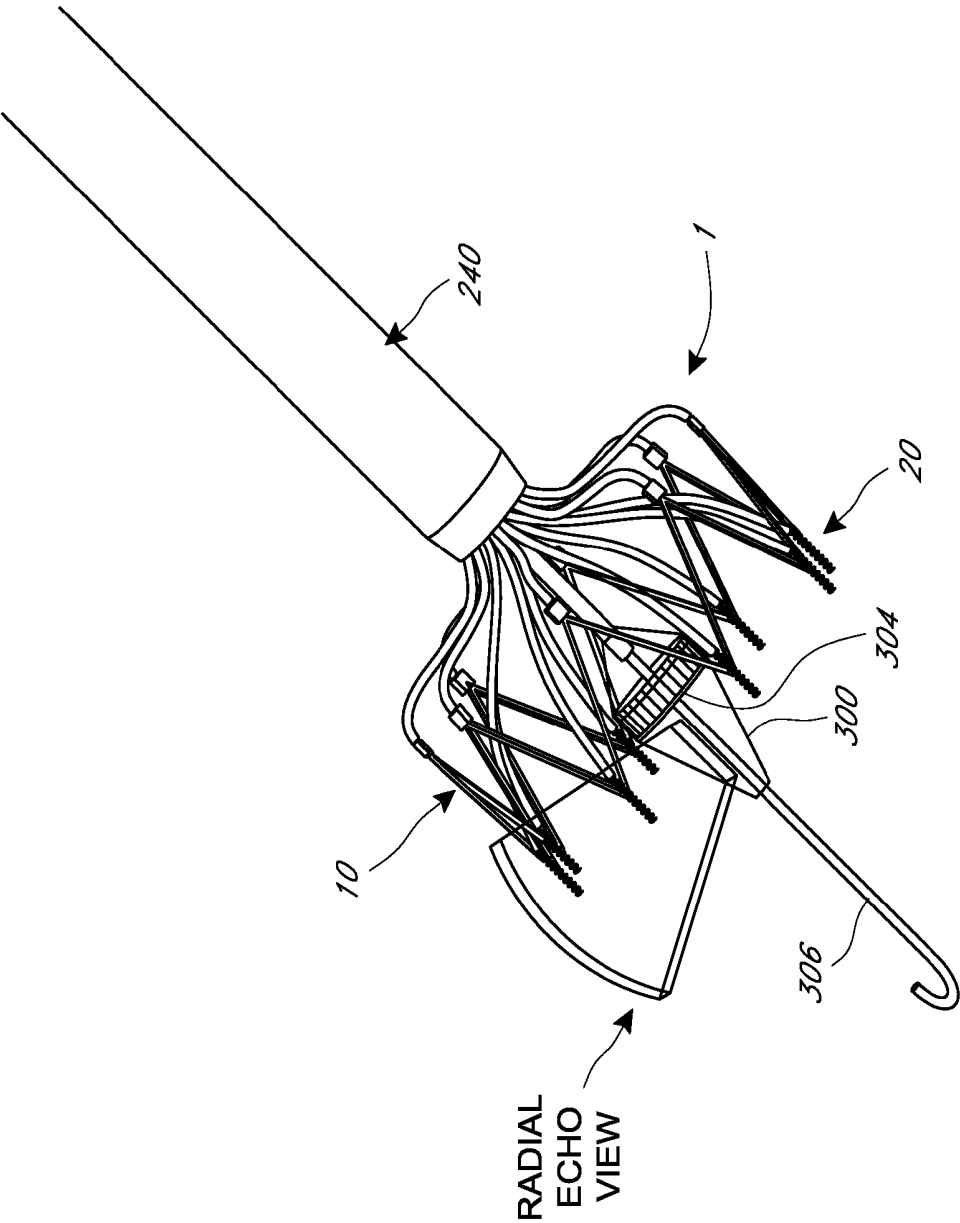

FIG. 3C

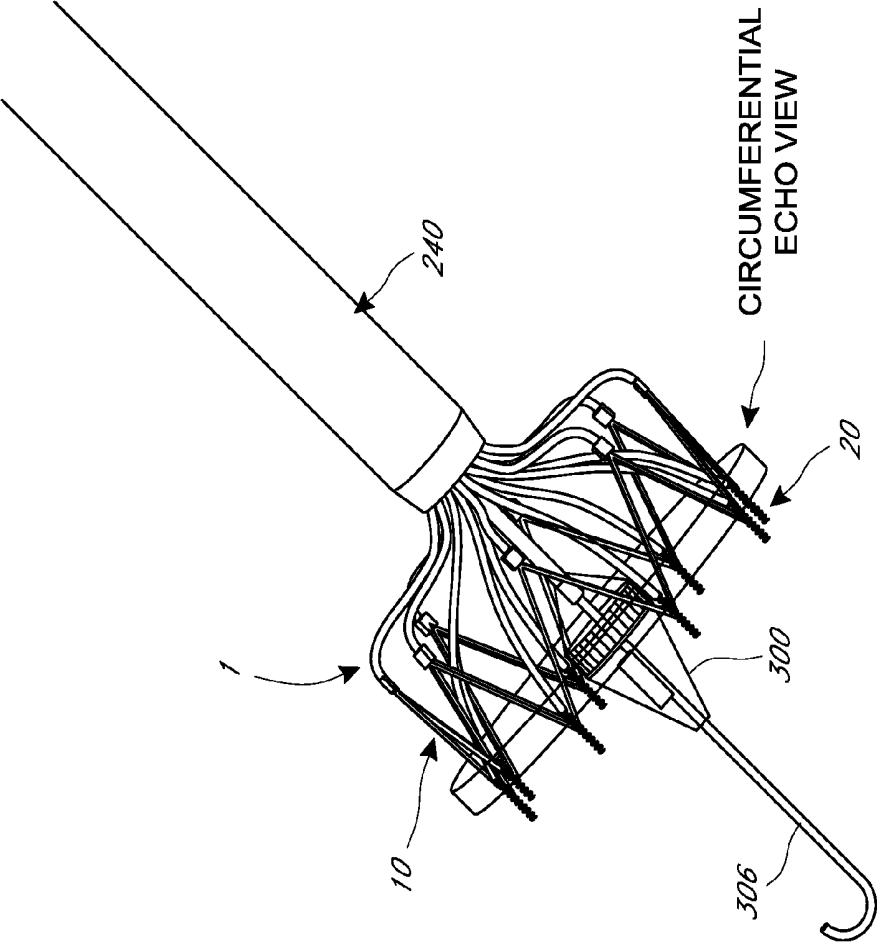

FIG. 3D

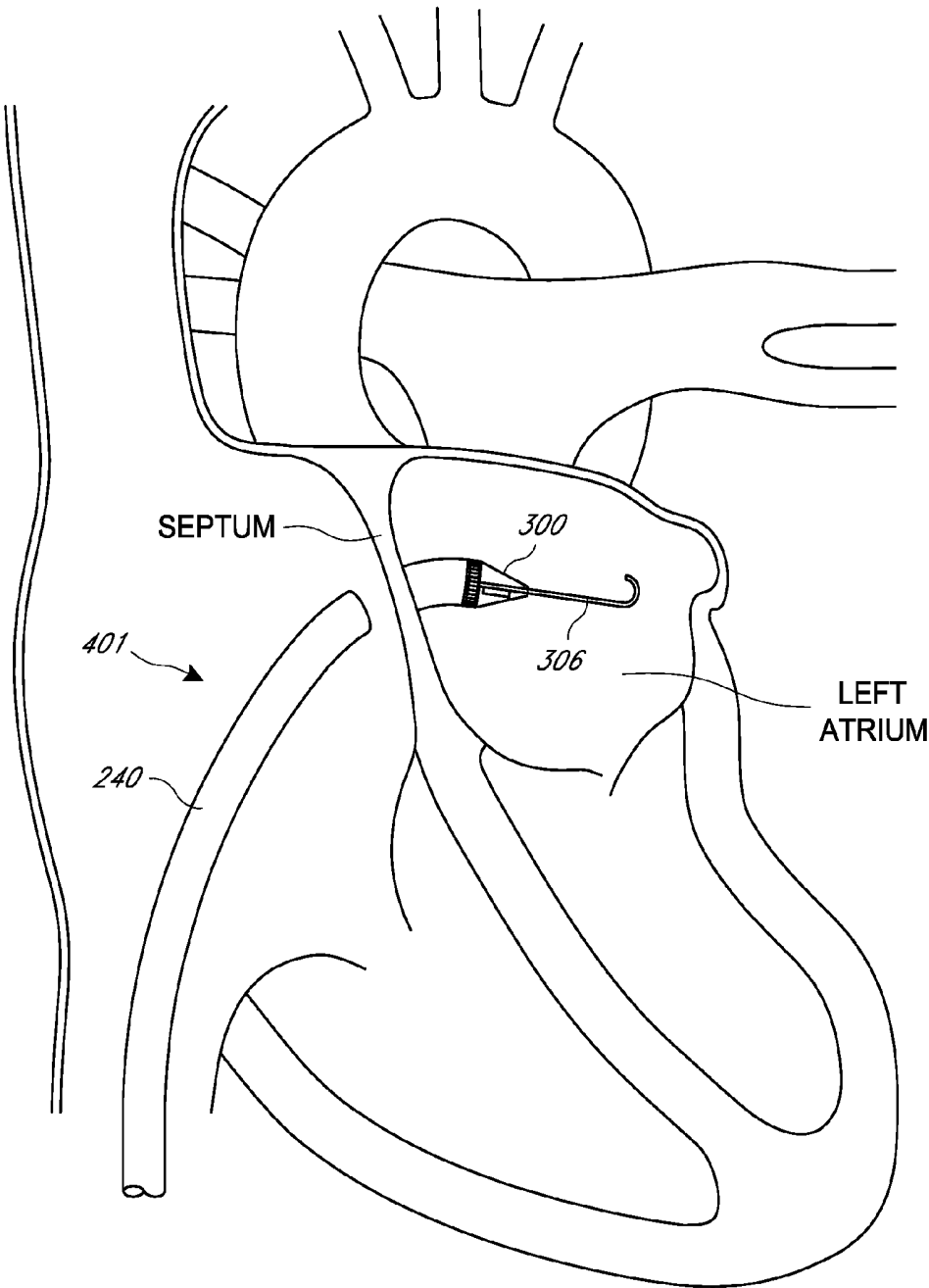

FIG. 4A

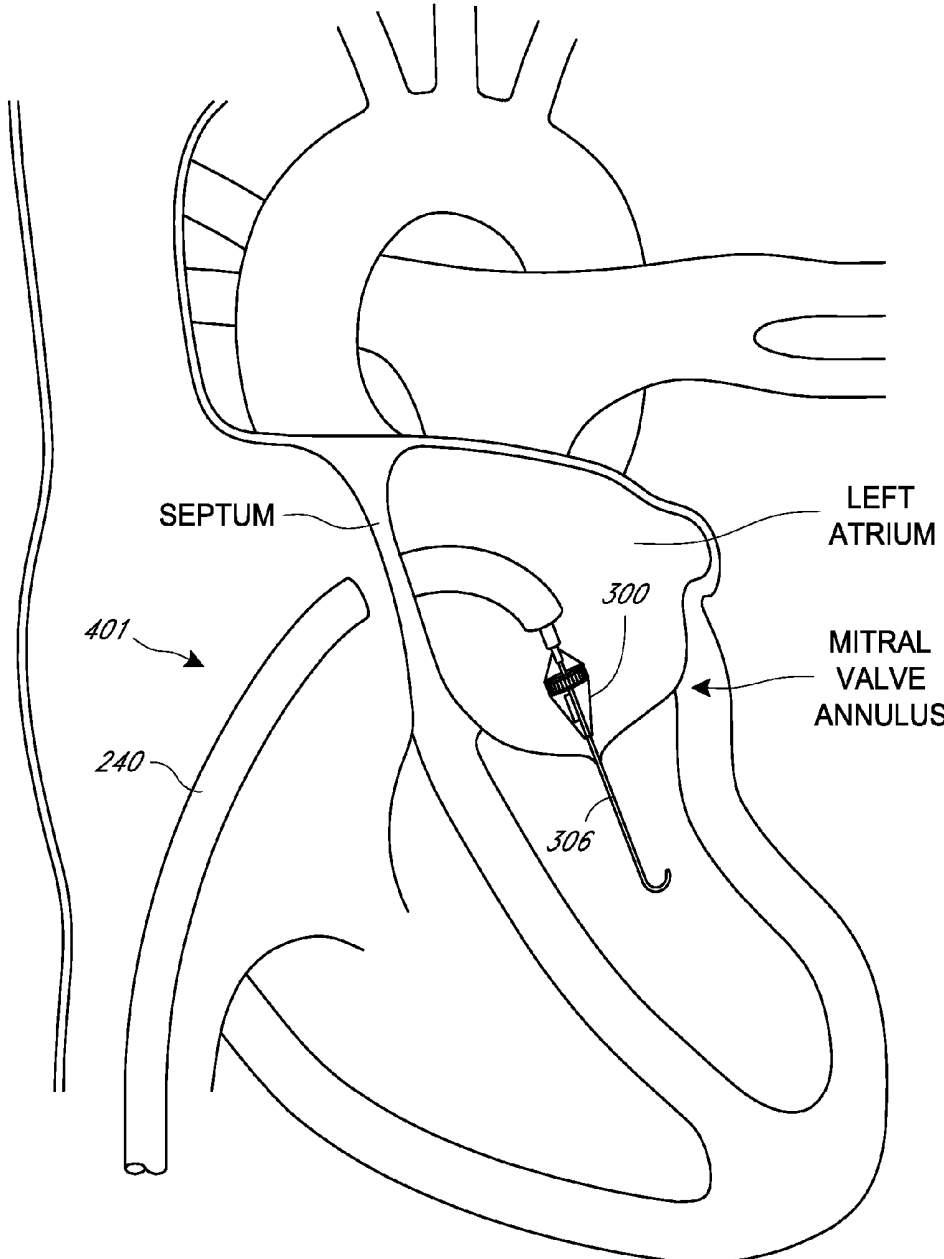

FIG. 4B

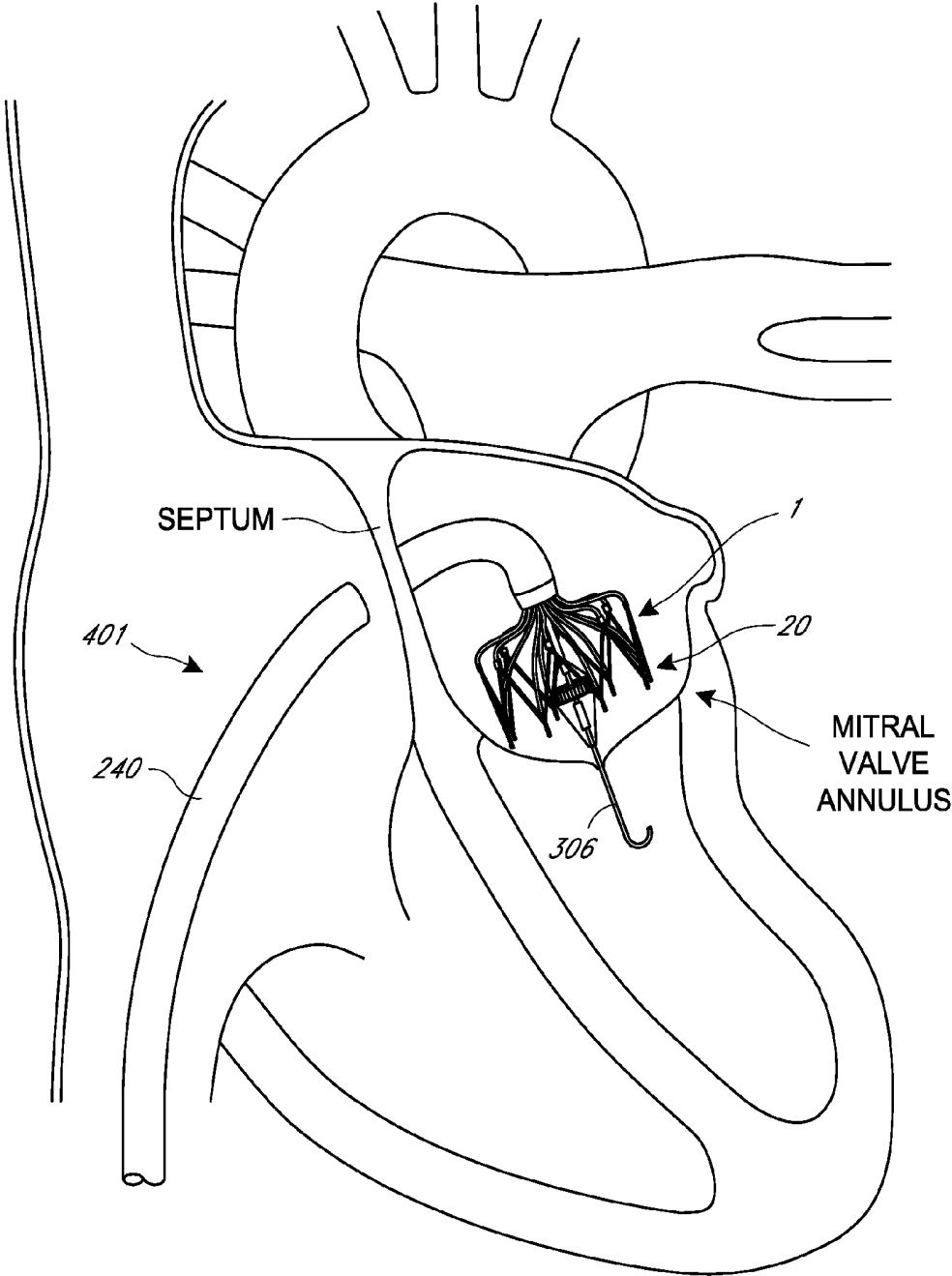

FIG. 4C

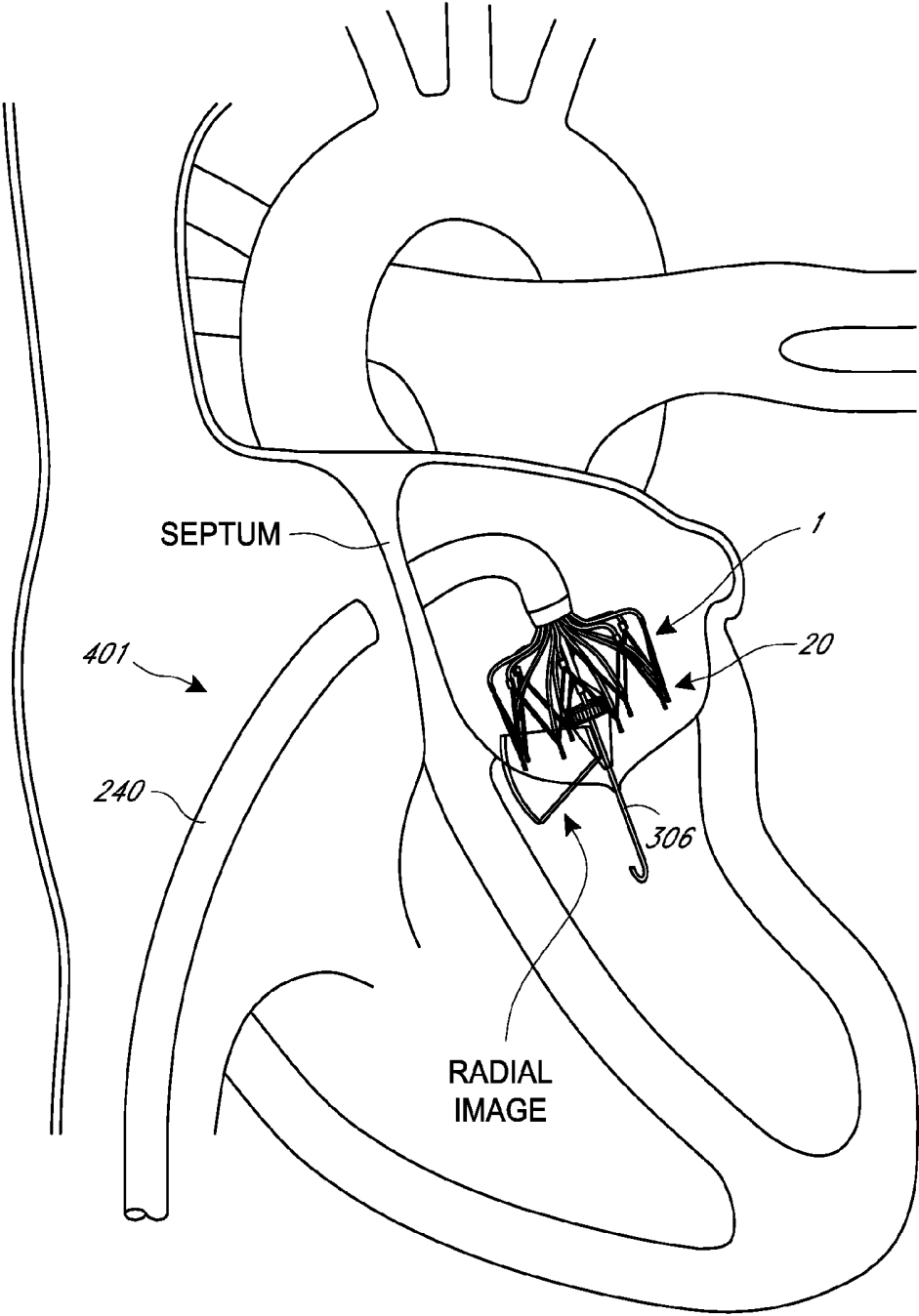

FIG. 4D

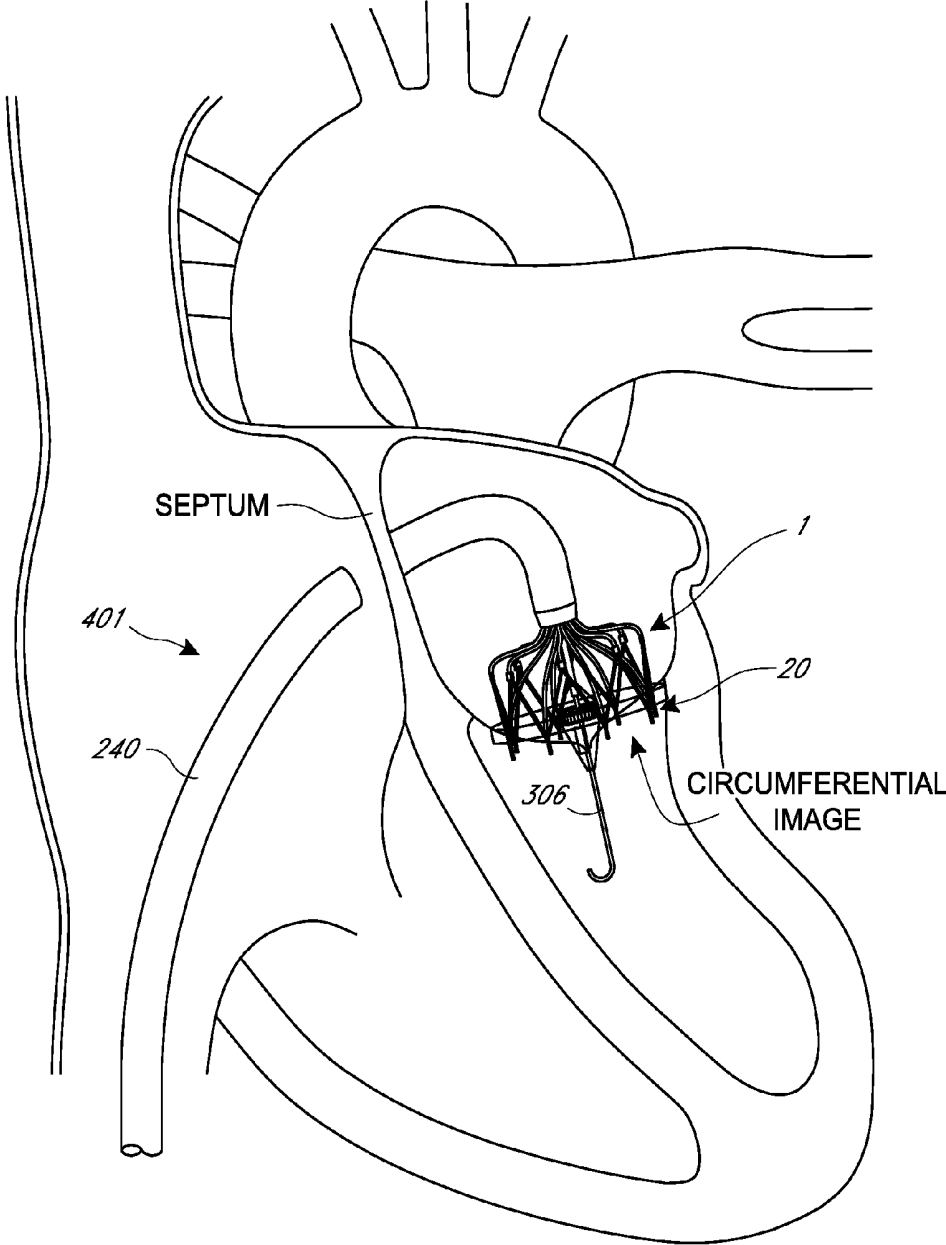

FIG. 4E

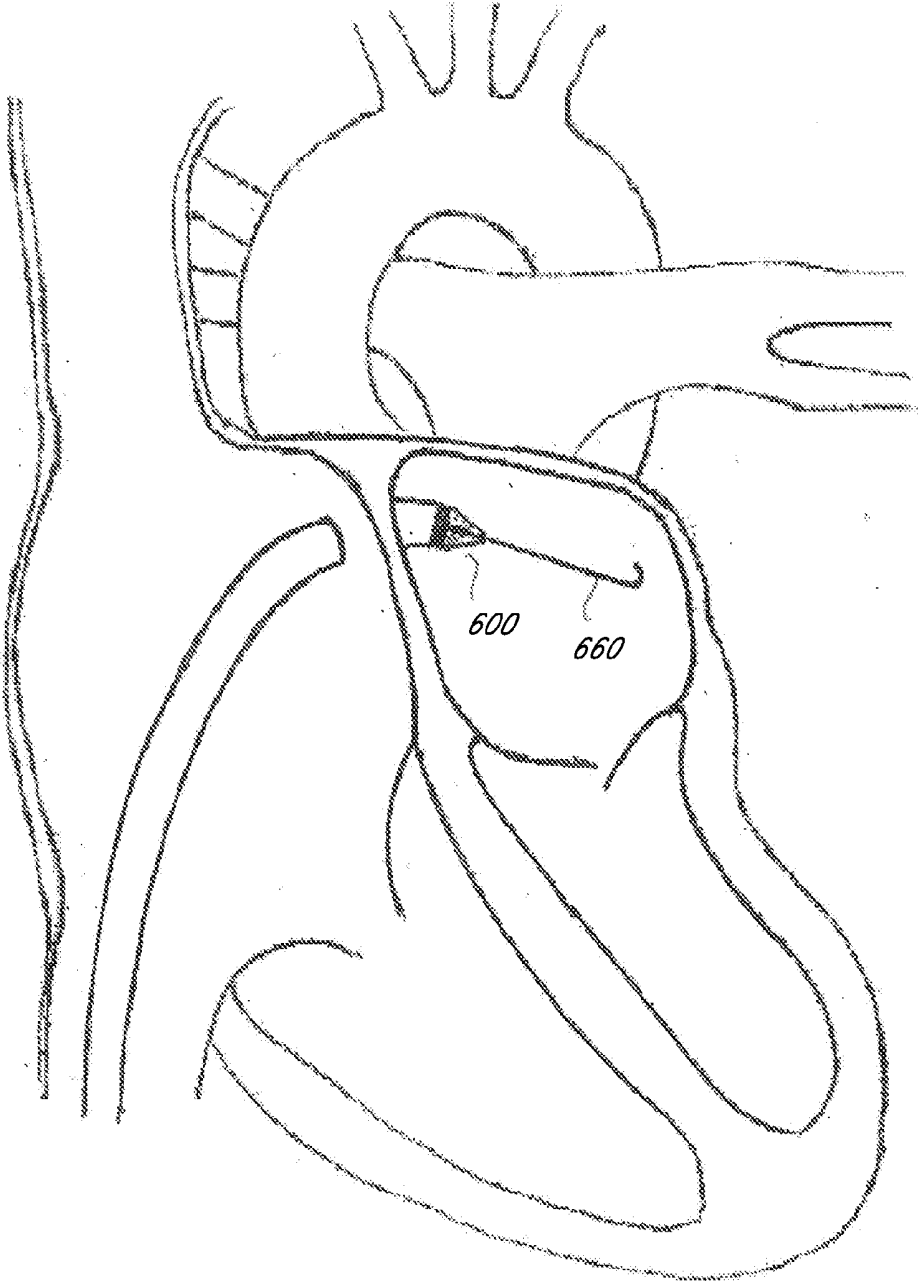

FIG. 5A

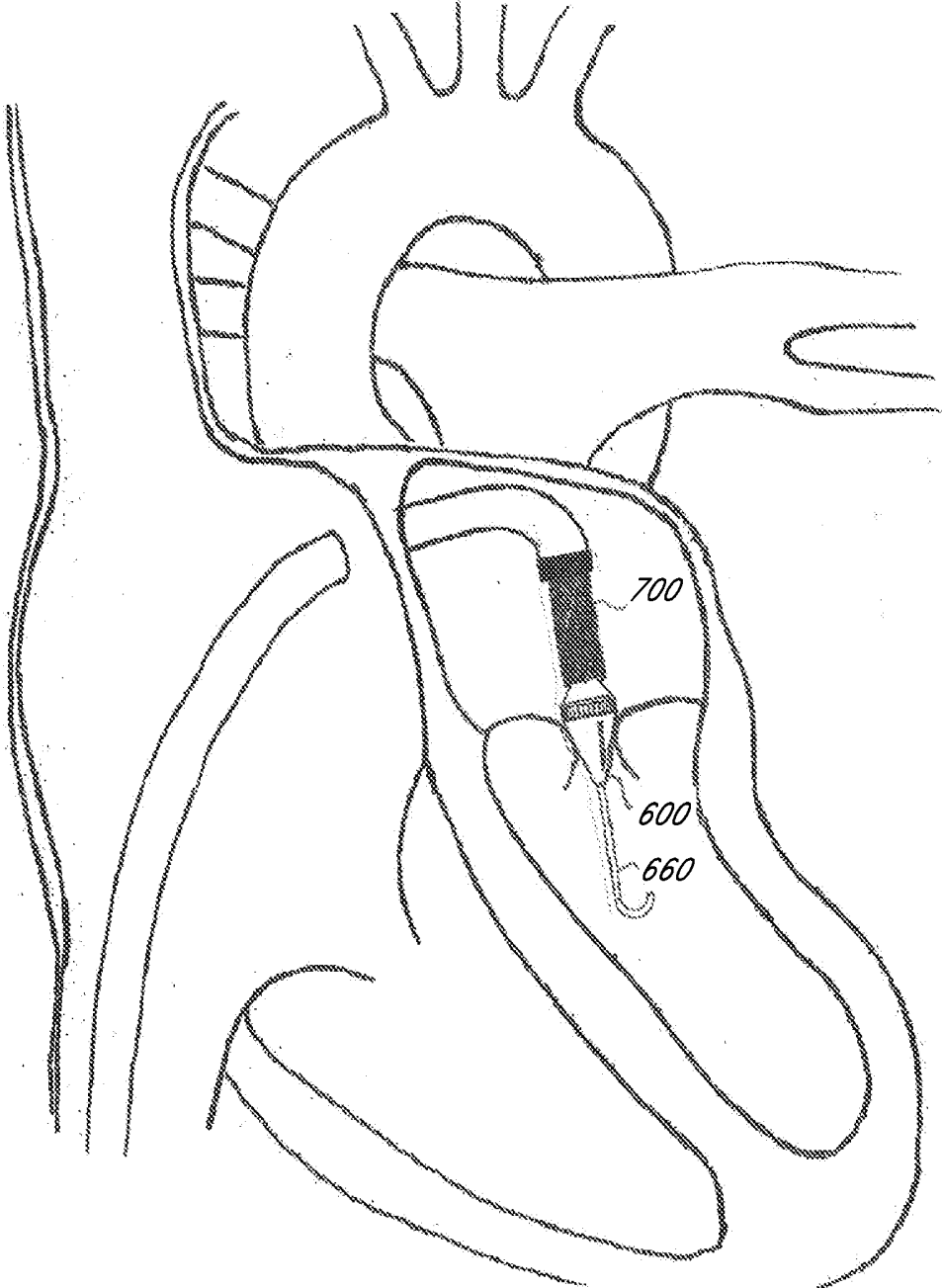

FIG. 5B

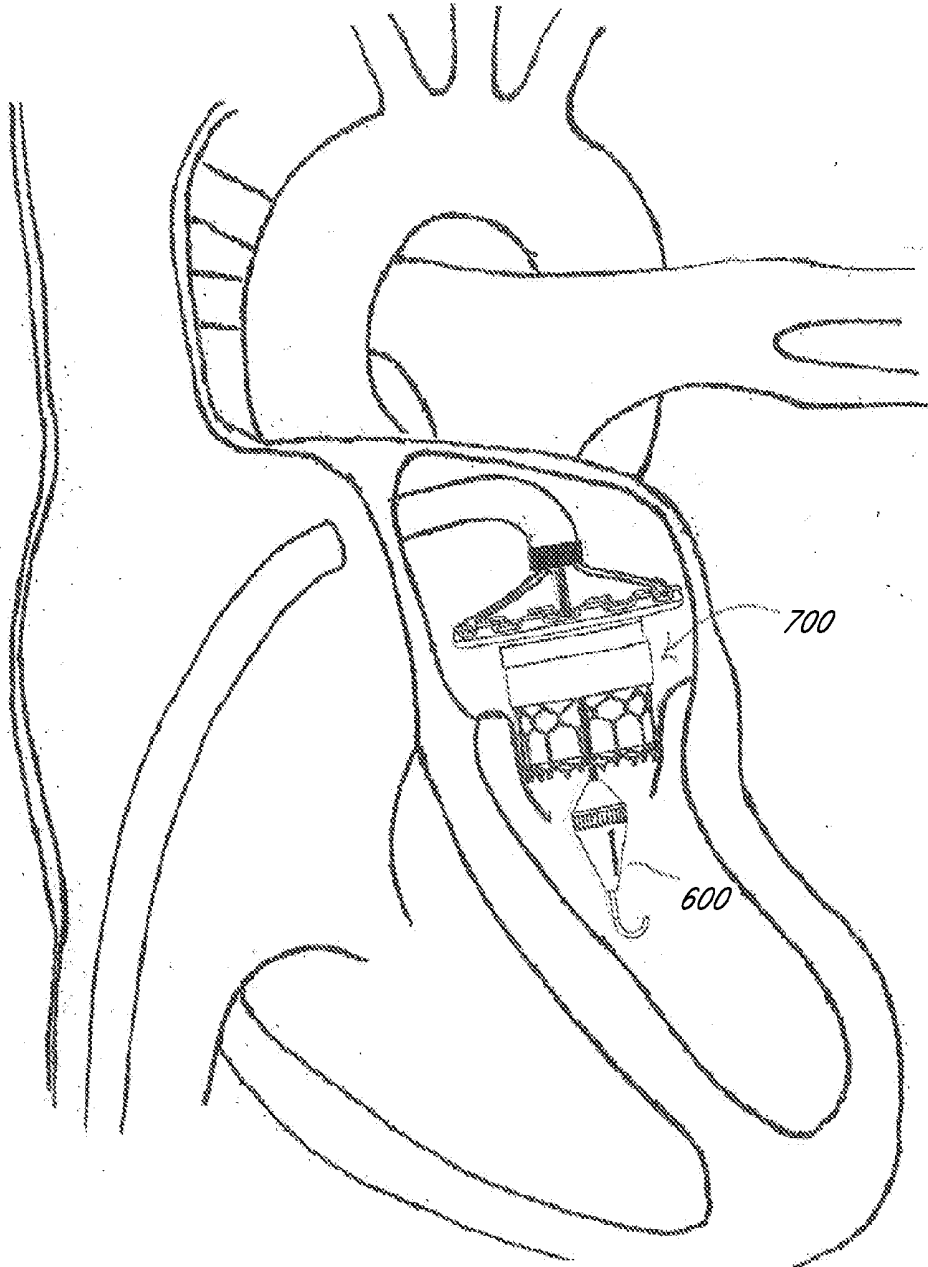

FIG. 5C

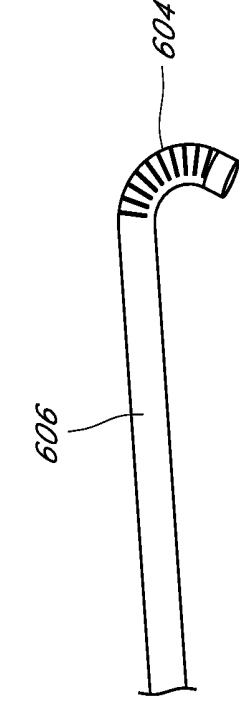

FIG. 6A

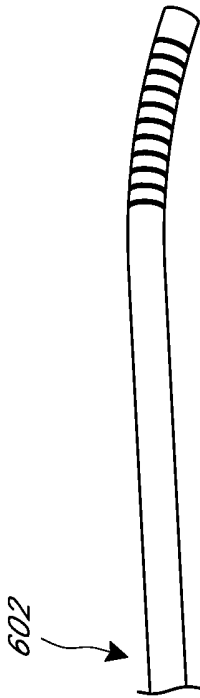

FIG. 6B

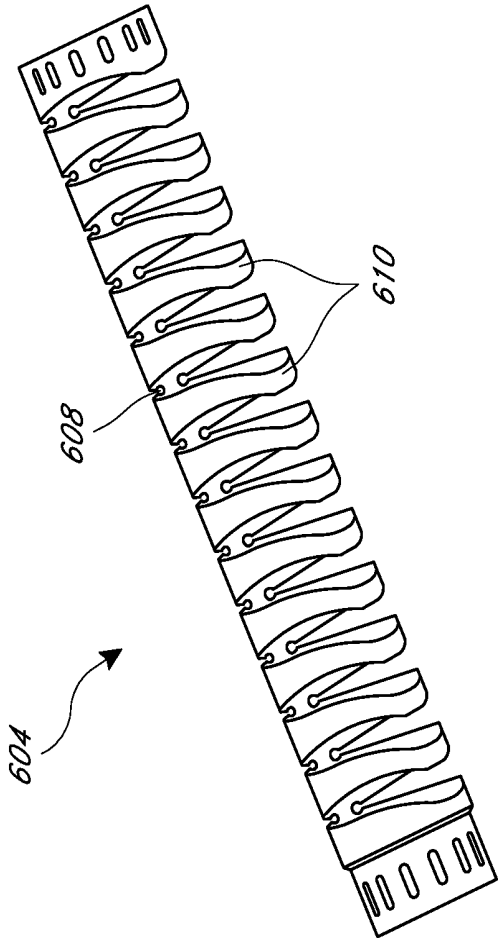

FIG. 7A

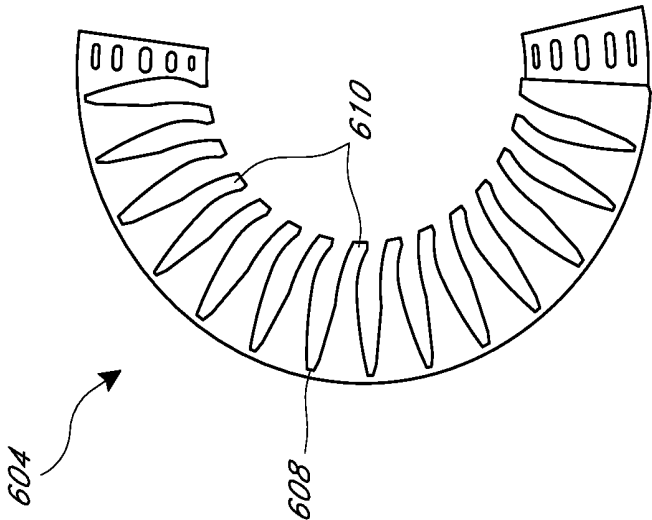

FIG. 7B

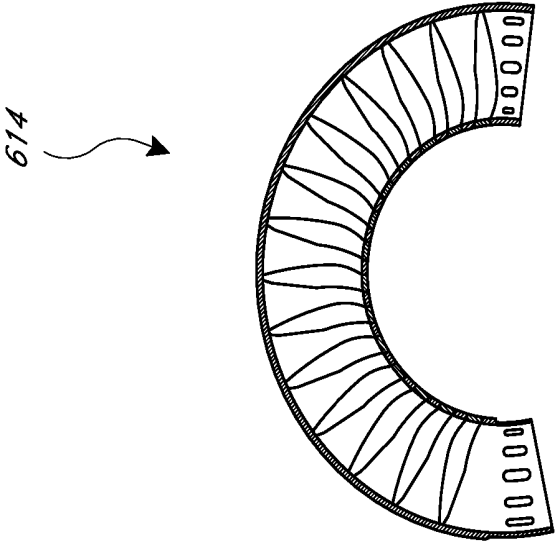

FIG. 8B

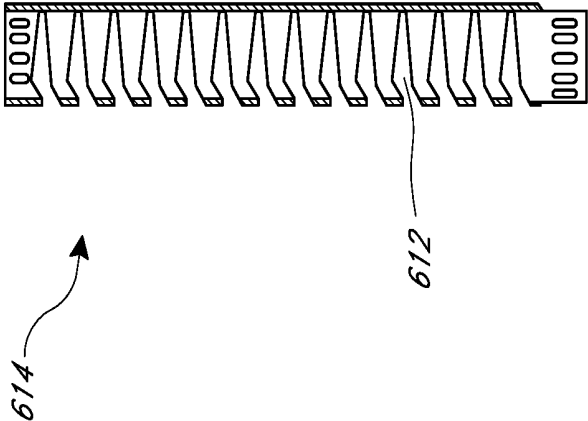

FIG. 8A

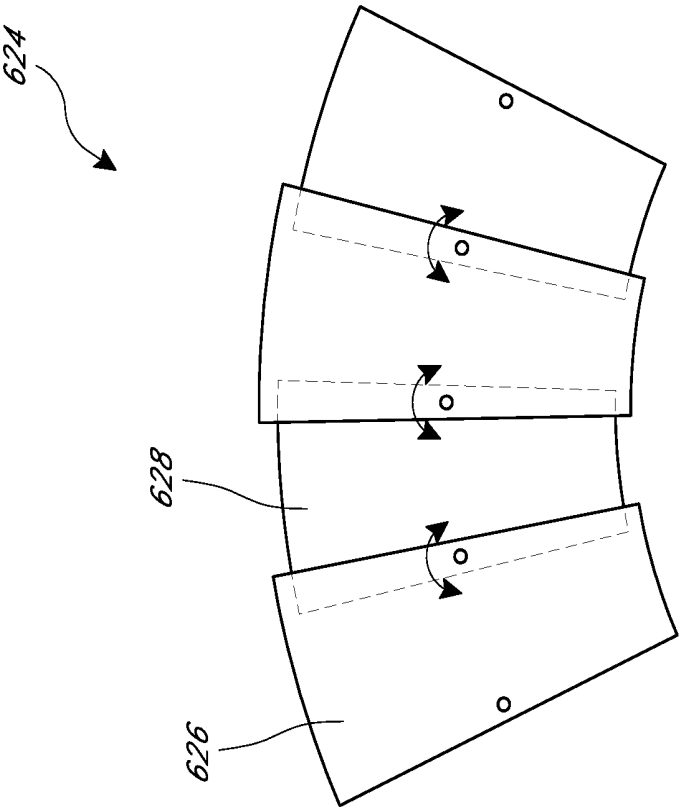

FIG. 9

**METHODS FOR DELIVERY OF HEART
VALVE DEVICES USING INTRAVASCULAR
ULTRASOUND IMAGING**

**INCORPORATION BY REFERENCE TO ANY
PRIORITY APPLICATIONS**

[0001] Any and all applications for which a foreign or domestic priority claim is identified in the Application Data Sheet as filed with the present application are hereby incorporated by reference under 37 CFR 1.57. For example, this application claims the benefit of priority under 35 U.S.C. §119(e) of U.S. Provisional Application No. 62/234,592 entitled “HEART VALVE DELIVERY SYSTEM WITH INTRAVASCULAR ULTRASOUND IMAGING CAPABILITY” and filed on Sep. 29, 2015, the entire disclosure of which is incorporated herein by reference for all purposes and forms a part of this specification.

BACKGROUND

[0002] Field

[0003] In general, features related to systems and methods of delivering implantable medical devices are described. For example, delivery and positioning systems and methods for implanting various devices in a heart valve, for example to treat cardiac valve insufficiency, are described.

[0004] Description of the Related Art

[0005] Heart valve incompetency is a serious problem. For example, heart disease can cause the chambers of the heart to expand and weaken. With specific reference to the mitral valve, as a result of aging or disease, the left ventricle dilates and the papillary muscles are displaced. Consequently, the annulus of the mitral heart valve dilates excessively. In this state of dilation, valve leaflets no longer effectively close, or coapt, during systolic contraction. Consequently, regurgitation (i.e. retrograde flow back across the valve that should be closed) of blood occurs during ventricular contraction. Cardiac output is thus decreased.

[0006] This condition is typically addressed by the surgical implantation of an annuloplasty ring. A surgeon positions the annuloplasty ring proximate the valve annulus and sutures it in place thereby restoring the valve annulus to approximately its native configuration. The valve leaflets can now function normally again.

[0007] This procedure is invasive as it is performed open chest and is also time consuming. In open heart surgery, the patient is put on cardiopulmonary bypass with its associated risks of morbidity and mortality due to stroke, thrombosis, heart attack and extended recovery time.

[0008] There is, therefore, a need for less invasive and more efficient solutions to these problems that avoid the aforementioned drawbacks.

SUMMARY

[0009] The embodiments disclosed herein each have several aspects no single one of which is solely responsible for the disclosure's desirable attributes. Without limiting the scope of this disclosure, its more prominent features will now be briefly discussed. After considering this discussion, and particularly after reading the section entitled “Detailed Description,” one will understand how the features of the embodiments described herein provide advantages over existing systems, devices and methods.

[0010] The following disclosure describes non-limiting examples of some embodiments. For instance, other embodiments of the disclosed systems and methods may or may not include the features described herein. Moreover, disclosed advantages and benefits can apply only to certain embodiments of the invention and should not be used to limit the disclosure.

[0011] Systems and methods of delivering a heart valve implant using ultrasound imaging are described. The implant is intended to be delivered in a minimally invasive percutaneous manner, such as transfemorally, transeptally, or transapically. The implant may instead be implanted surgically, in that it should reduce the duration of the procedure and, more particularly, the duration that the patient is on bypass. Furthermore, it should be recognized that the development can be directed to mitral valve or tricuspid valve procedures.

[0012] The development relates to the implant and delivery systems, and associated methods of use of each. The implant is a device capable of extending out to the dilated annulus of a heart valve, engaging the tissue of the heart valve annulus, and gathering or cinching it in to a smaller diameter. The implant includes a tubular frame with moveable struts, where pairs of adjacent struts form apexes. The apexes have collars at least partially surrounded the apex. After engaging heart valve annulus tissue with the implant, the collars can be moved down the apex to decrease the angle between the adjacent struts, causing the tubular frame to contract in width. This pulls the tissue of the heart valve annulus closer together. In some embodiments, the device has a ring-like member formed of a shape memory material that can be expanded, e.g. forcibly expanded, to engage and penetrate the tissue of the heart valve annulus. When the force is removed, the device moves, e.g. pulls, the tissue of the heart valve annulus closer together. The implant thus reconfigures the valve annulus down to a smaller diameter, reducing and/or eliminating problems associated with the valve, such as regurgitation.

[0013] A delivery system and associated methods are also disclosed that comprise a catheter and imaging and positioning features to maneuver the distal end of the catheter and the device into the desired position above and proximate the heart valve annulus. Additionally, the catheter can have modified distal and intermediate sections to facilitate the bending requirements encountered during intravascular or transeptal delivery of the device. Transeptal delivery may be used, for example, with procedures involving the mitral valve. The delivery system can be used with the implant described herein as well as other implantable devices.

[0014] Moreover, the development also provides an artificial heart valve with a modified ring-like structure that not only provides for reduction of the heart valve annulus, but also displaces one or more defective heart valve leaflets. The artificial valve may include the various implant devices described herein having the one or more leaflets attached thereto.

[0015] In one aspect, a method of anchoring an implant in the heart is described. The method comprises advancing a deployment catheter to a deployment site in a heart, the deployment catheter releasably carrying an implant having at least one tissue anchor, positioning an imaging element in the heart adjacent the implant, visualizing a relationship

between the tissue anchor and an anatomical landmark in the heart, and attaching the implant by driving the tissue anchor into tissue in the heart.

[0016] In some embodiments, the positioning an imaging element step comprises advancing the imaging element transvascularily along a same access path followed by the deployment catheter. In some embodiments, the positioning an imaging element step comprises advancing the imaging element through a lumen in the deployment catheter.

[0017] In some embodiments, the positioning an imaging element step comprises advancing the imaging element transvascularily along an access path that is different from an access path followed by the deployment catheter.

[0018] In some embodiments, the positioning an imaging element step comprises directing the imaging element to a predetermined relationship with the deployment catheter using an alignment structure. In some embodiments, the imaging element is carried by an imaging catheter and the positioning step comprises centering the imaging catheter within the implant using the alignment structure. In some embodiments, the centering step comprises inclining at least one alignment arm with respect to a longitudinal axis of the deployment catheter.

[0019] In some embodiments, the visualizing step comprises capturing at least one radial image. In some embodiments, the visualizing step comprises capturing at least one circumferential image. In some embodiments, the visualizing step comprises visualizing a heart valve annulus.

[0020] In some embodiments, the visualizing step comprises visualizing a Mitral valve annulus. In some embodiments, the attaching an implant step comprises attaching a Mitral valve annulus reshaping device. In some embodiments, the attaching an implant step comprises attaching a Mitral valve leaflet repair device. In some embodiments, the attaching an implant step comprises attaching a replacement Mitral valve.

[0021] In some embodiments, the attaching step comprises driving at least two anchors into tissue in the heart. In some embodiments, the attaching step comprises driving at least six anchors into tissue in the heart.

[0022] In some embodiments, the attaching step comprises rotating the anchor.

[0023] In some embodiments, the method further comprises the step of capturing a circumferential image following the attaching step. In some embodiments, the method further comprises the step of releasing the implant from the deployment catheter following the capturing a circumferential image step. In some embodiments, the method further comprises the step of manipulating at least one anchor following the capturing a circumferential image step.

[0024] In some embodiments, the visualizing step comprises capturing a field of view that includes at least a portion of the implant and of a Mitral valve leaflet.

[0025] In some embodiments, the deployment catheter has a central longitudinal axis and further comprising the step of deflecting the imaging element away from the central longitudinal axis. In some embodiments, the method comprises deflecting the imaging element in the direction of a tissue anchor.

[0026] In some embodiments, the method comprises capturing a first image of a first anchor, repositioning the imaging element, and capturing a second image of a second anchor. In some embodiments, the repositioning step comprises rotating the imaging element about an axis. In some

embodiments, the repositioning step comprises rotating the imaging element about an axis using a rotational drive mechanism. In some embodiments, the repositioning step comprises manually rotating the imaging element about the axis.

[0027] In some embodiments, the imaging element is carried by an imaging catheter, further comprising locking a proximal engagement structure on the imaging catheter to a complementary engagement structure on the deployment catheter.

[0028] In another aspect, a method of delivering an implant proximate a cardiac valve annulus is described. The method comprises advancing a distal end of a delivery catheter proximate the cardiac valve annulus, advancing the implant through the distal end of the delivery catheter proximate the cardiac valve annulus, advancing a distal end of an ultrasound catheter proximate the cardiac valve annulus, the distal end of the ultrasound catheter including one or more ultrasonic transducers, capturing an ultrasound image of the implant and the cardiac valve annulus with the one or more ultrasonic transducers, and anchoring the implant to the cardiac valve annulus.

[0029] In some embodiments, the method further comprises rotating the distal end of the ultrasound catheter proximate the cardiac valve annulus to a plurality of rotational positions; and capturing a series of ultrasound images of the implant and the cardiac valve annulus with the one or more ultrasonic transducers at the plurality of rotational positions.

[0030] In some embodiments, the one or more ultrasonic transducers includes a radial ultrasonic transducer, and wherein capturing the series of ultrasound images comprises capturing one or more radial images of the implant and the cardiac valve annulus to properly position anchors of the implant for insertion into the cardiac valve annulus. In some embodiments, the one or more ultrasonic transducers includes a circumferential ultrasonic transducer, and wherein capturing the series of ultrasound images further comprises capturing one or more circumferential images of the implant and the cardiac valve annulus before anchoring the implant to the cardiac valve annulus. In some embodiments, the one or more ultrasonic transducers includes a circumferential ultrasonic transducer, and wherein capturing the series of ultrasound images further comprises capturing one or more circumferential images of the implant and the cardiac valve annulus after anchoring the implant to the cardiac valve annulus.

[0031] In some embodiments, the method comprises advancing the distal end of the delivery catheter proximate the cardiac valve annulus via the femoral vein or the iliac vein. In some embodiments, the method comprises advancing the distal end of the ultrasound catheter proximate the cardiac valve annulus through the delivery catheter. In some embodiments, the method comprises advancing the distal end of the ultrasound catheter proximate the cardiac valve annulus separately from the delivery catheter. In some embodiments, the method comprises advancing the distal end of the ultrasound catheter proximate the cardiac valve annulus through the aortic valve.

[0032] In some embodiments, the ultrasound catheter comprises a proximal end having a guidewire entry port, a distal end having a guidewire exit port, and a guidewire extending through the entry and exit ports.

[0033] In some embodiments, the ultrasound catheter is an intravascular cardiac echography (ICE) catheter.

[0034] In some embodiments, the method comprises centering the ultrasound catheter relative to the implant before capturing the ultrasound image and anchoring the implant. In some embodiments, the method comprises the ultrasound catheter is centered relative to the implant by coupling the implant with the ultrasound catheter via a plurality of radial arms of a centering frame that extend from the implant to the ultrasound catheter.

[0035] In some embodiments, the implant comprises a series of struts defining a tubular frame and an axis and forming a plurality of upper and lower crowns, a plurality of anchors coupled with the lower crowns of the frame and configured to translate axially relative to the frame to engage cardiac tissue proximate the cardiac valve annulus, and a plurality of collars at least partially surrounding the upper crowns and configured to translate axially relative to the frame to adjust a width of the implant. In some embodiments, anchoring the implant to the cardiac valve annulus comprises rotating the plurality of anchors into the cardiac tissue. In some embodiments, the method comprises translating the plurality of collars axially relative to the frame to decrease the width of the implant.

[0036] In some embodiments, the implant is a cardiac valve replacement and comprises a series of struts defining a tubular frame and an axis and forming a plurality of lower crowns, a plurality of anchors coupled with the lower crowns of the frame and configured to translate axially relative to the frame to engage cardiac tissue proximate the cardiac valve annulus, and a plurality of valve leaflets coupled with the frame. In some embodiments, anchoring the implant to the cardiac valve annulus comprises rotating the plurality of anchors into the cardiac tissue. In some embodiments, the implant further comprises a housing coupled with the frame, and wherein the leaflets are coupled with the frame via the housing. In some embodiments, the implant further comprises a plurality of upper crowns defined by the series of struts, and a plurality of collars at least partially surrounding the upper crowns and configured to translate axially relative to the frame to adjust a width of the implant. In some embodiments, the implant further comprises an atrial flange.

[0037] In some embodiments, the cardiac valve annulus is a mitral valve annulus. In some embodiments, the cardiac valve annulus is a tricuspid valve annulus.

BRIEF DESCRIPTION OF THE DRAWINGS

[0038] The foregoing and other features of the present disclosure will become more fully apparent from the following description and appended claims, taken in conjunction with the accompanying drawings. Understanding that these drawings depict only several embodiments in accordance with the disclosure and are not to be considered limiting of its scope, the disclosure will be described with additional specificity and detail through use of the accompanying drawings. In the following detailed description, reference is made to the accompanying drawings, which form a part hereof. In the drawings, similar symbols typically identify similar components, unless context dictates otherwise. The illustrative embodiments described in the detailed description, drawings, and claims are not meant to be limiting. Other embodiments may be utilized, and other changes may be made, without departing from the spirit or

scope of the subject matter presented here. It will be readily understood that the aspects of the present disclosure, as generally described herein, and illustrated in the drawing, can be arranged, substituted, combined, and designed in a wide variety of different configurations, all of which are explicitly contemplated and make part of this disclosure.

[0039] FIGS. 1A through 1E are perspective views of various embodiments of delivery catheters having positioning and imaging capabilities and delivering various embodiments of heart valve implants for resizing the native valve annulus.

[0040] FIG. 2 is a side view of an embodiment of a modified intravascular cardiac echography (ICE) catheter for delivering, e.g. aligning and positioning, an implant and having a guidewire entering and exiting the catheter.

[0041] FIGS. 3A-3D are perspective views of another embodiment of an ICE catheter and delivery system for delivering, e.g. aligning and positioning, an implant and having a circular array of sensors at the tip of the catheter, e.g. for radial and/or circumferential echo views.

[0042] FIGS. 4A through 4E are sequential perspective views of an embodiment of a delivery system with imaging capability showing an embodiment of a method for the delivery, positioning and anchoring of an embodiment of an implant for resizing the native valve annulus.

[0043] FIGS. 5A-5C are sequential perspective views of an embodiment of a delivery system with imaging capability showing an embodiment of a method for the delivery, positioning and anchoring of an embodiment of a replacement heart valve implant.

[0044] FIGS. 6A and 6B are side views of an embodiment of a steerable catheter shown in straight and flexed states, respectively, that may be used in the various systems and methods described herein.

[0045] FIGS. 7A and 7B are side views of an embodiment of a distal section of a steerable catheter having a spine that may be used in the various systems and methods described herein.

[0046] FIGS. 8A and 8B are side views of another embodiment of a distal section of a steerable catheter having a thin film that may be used in the various systems and methods described herein.

[0047] FIG. 9 is a side view of another embodiment of a distal section of a steerable catheter having nesting elements that may be used in the various systems and methods described herein.

DETAILED DESCRIPTION

[0048] The following detailed description is directed to certain specific embodiments of the development. In this description, reference is made to the drawings wherein like parts or steps may be designated with like numerals throughout for clarity. Reference in this specification to “one embodiment,” “an embodiment,” or “in some embodiments” means that a particular feature, structure, or characteristic described in connection with the embodiment is included in at least one embodiment of the invention. The appearances of the phrases “one embodiment,” “an embodiment,” or “in some embodiments” in various places in the specification are not necessarily all referring to the same embodiment, nor are separate or alternative embodiments necessarily mutually exclusive of other embodiments. Moreover, various features are described which may be exhibited by some embodiments and not by others. Similarly, various require-

ments are described which may be requirements for some embodiments but may not be requirements for other embodiments.

[0049] Various heart valve implants may be delivered proximate to, above and/or within, the cardiac valve annulus. Unless otherwise stated, “valve” as used herein may refer to either the tricuspid or mitral valve of the heart. The implant may be subsequently implanted in the annular cardiac tissue just above the plane of the valve orifice. In some embodiments, the implant may be a heart valve replacement including valve leaflets, which can be implanted in annular cardiac tissue and extend into the valve annulus.

[0050] Particular features for various embodiments of an implant, of a delivery system, and of related systems and methods of use of the delivery system (either together or separately), are described herein. The implant, delivery system, and related systems and methods of use may have the same or similar features and/or functionalities as other implants, delivery systems, and related systems and methods of use as described, for example, in U.S. patent application Ser. No. 14/861,877 entitled “ADJUSTABLE ENDOLUMENAL IMPLANT FOR RESHAPING MITRAL VALVE ANNULUS and filed on Sep. 22, 2015, and as described, for example, in U.S. Provisional Application No. 62/234,592 entitled “HEART VALVE DELIVERY SYSTEM WITH INTRAVASCULAR ULTRASOUND IMAGING CAPABILITY” and filed on Sep. 29, 2015, the entire disclosure of each of which is incorporated herein by reference for all purposes and forms a part of this specification. Thus, the description of particular features and functionalities herein is not meant to exclude other features and functionalities, such as those described in the references incorporated herein by reference or others within the scope of the development.

[0051] FIGS. 1A and 1B are perspective views of an embodiment of a distal end of a delivery catheter 40 that may be used to deliver various implants. The delivery catheter 40 has various positioning and imaging capabilities. The distal end of the delivery catheter 40 is maneuvered into position above the heart valve annulus. An implant 1A shown being delivered in FIGS. 1A-1B is for resizing the heart valve annulus. It is understood that a variety of different implants may be delivered with the delivery system and methods described herein. As shown, this particular implant includes a frame 250. The frame 250 has anchors 20 attached to a lower or distal portion of the frame 250 and extending distally therefrom. The frame 250 has an upper or proximal portion with collars 252 extending over upper crowns 251 of the frame 250. Only some of the collars 252, upper crowns 251 and anchors 20 are labelled for clarity. The collars 252 may be moved, e.g. distally, along the frame 250 by driver tubes 260 to resize the frame 250.

[0052] The frame 250, driver tubes 260, and an intravascular cardiac echography (or “ICE”) catheter 270 may be extended from the distal end of the delivery catheter 40. The drive tubes 260 are shown engaging corresponding upper crowns 252 of the frame 250. A centering frame 280 maintains concentric positioning of the ICE catheter 270 relative to the frame 250 during deployment, alignment and positioning of the frame 250 above and proximate to the target heart valve annulus tissue. The centering frame 280 maintains a generally centered position of the catheter 270 relative to the frame 250. By centering the ICE catheter within the frame 250, the operator need only rotate the ICE

catheter 270 to view each anchor 20 and placement of the anchors 20. Further, the ICE catheter 270 could be used to view various other individual features of the implant 1A, such as the collars 252, for instance to view the extent to which each collar 252 is advanced down and over upper crowns 251 of the frame 250, to more precisely adjust the size of the frame 250. The ICE catheter 270 could also provide significant benefit to an embodiment where a singular cinching mechanism or driver tube needs to be landed on each crown 251 of the frame 250 to adjust the sizing of the frame 250. An indexing feature (not shown) may also be provided on the ICE catheter 270, for example, such that actuation of the indexing feature by the operator causes the ICE catheter 270 to automatically move, or rotate, to the next anchor 20 position.

[0053] FIGS. 1C and 1D are perspective views of an embodiment of an implant 1B being delivered and implanted by the delivery catheter 40. The implant 1B may be analogous to the implant 1A. By “analogous” it is meant the two features may have the same or similar features and/or functionalities. As shown in FIGS. 1C and 1D, the implant 1B includes a frame 10 with struts 12 forming upper apexes or crowns 14 and lower apexes or crowns 16. The lower crowns 16 have openings 18, such as holes, aligned to receive the anchors 20 there through. For clarity, only some of the upper crowns 14, lower crowns 16, struts 12 and anchors 20 are labelled in FIGS. 1C and 1D. The anchors 20 may be rotated to move distally through the openings 18. The implant 1B is intended to be delivered proximate to and above a cardiac valve (tricuspid, mitral) annulus, and subsequently implanted in the annular cardiac tissue just above the plane of the valve orifice.

[0054] Driver tubes 22, having proximal portions 22' extending out of the delivery catheter 40, are provided for rotationally engaging the anchors 20. Manipulation, for example rotation, of the driver tubes 22 by the operator causes the anchors 20 to advance towards, engage with and penetrate cardiac tissue to secure frame 10 into the annulus approximate and above the valve. The anchors 20 may be advanced individually one at a time, some advanced together, or all advanced together. In some embodiments, the driver tube 22 may rotate relative to the proximal portion 22'. In some embodiments, the driver tube 22 and proximal portion 22' are part of the same, continuous driver tube and/or the entire tube 22 and 22' may rotate together.

[0055] An embodiment of an ultrasound catheter 30, such as the Acuson IPX8 AcuNav catheter, is shown contained within and advanced down a central lumen of the delivery catheter 40. The ultrasound catheter 30 may be analogous to the ICE catheter 270. In some embodiments, by rotating the ultrasound catheter 30 around the inside of the valve annulus, the relative position of the frame 10, and of any valve leaflets, will be seen for accurate positioning of the anchors 20 around and above the valve annulus.

[0056] In some embodiments, the ultrasound catheter 30 is contained within and advanced down an offset, non-central lumen of the delivery catheter 40. In this manner, the ultrasound catheter 30 would not interfere with the frame 10, its attachments or other features, and the driver components. In some embodiments, the ultrasound catheter 30 may be located and steered to the side of the annulus to image, allowing for less rotation to more quickly view the anchor points of the frame 10. An offset lumen could exit more proximally with regard to the distal end of the delivery

catheter 40. This more proximal exit would reduce the overall profile or diameter of the distal end of the delivery catheter 40. In addition, this more proximal exit port would enable a view of the valve annulus from above. The offset lumen could also be compressible allowing for an even smaller profile until the ultrasound catheter 40 is advanced through the offset lumen.

[0057] While the ultrasound catheter 30 is shown integrated into the same delivery system as the delivery catheter 40, in some embodiments the ultrasound catheter 30 could otherwise be introduced secondarily through another entry site, such as through the aortic valve, and placed near or inside the implant for imaging and placement of the anchors 20.

[0058] FIG. 1E is a perspective view of an embodiment of a centering frame 32 coupled to the ultrasound catheter 30 and to an implant 1C. The implant 1C may be analogous the implants 1A and 1B. The centering frame 32 has centering arms 34 connected to a centering hub 36 that is mounted on the ultrasound catheter 30. As the distal end of the delivery catheter 40 is maneuvered into position above the heart valve annulus, the centering frame 32 maintains concentric positioning of the ultrasound catheter 30 relative to the frame 10 during deployment, alignment and positioning of the frame 10 above and proximate to the target heart valve annulus tissue. The centering aspect is desirable, for example, because if the ultrasound catheter 30 remains centered within the frame 10, the operator such as a surgeon or technician need only rotate the ultrasound catheter 30 to view each anchor 20 and placement of each anchor 20. There may also be an indexing feature (not shown) on the ultrasound catheter 30 such that actuation of the indexing feature by the operator causes the ultrasound catheter 30 to automatically move, or rotate, to the next anchor position. The centering frame 32 maybe used with delivery of the various implants described herein, such as the annulus resizing implants and/or the heart valve replacement implants.

[0059] FIG. 2 is a side view of an embodiment of the ICE catheter 270. The ICE catheter 270 as shown includes a guidewire entry port 292 and a guidewire exit port 294 which together accept the guidewire 296. This embodiment allows the ICE catheter 270 to be delivered separately from the frame 10 thereby reducing the overall diameter of the delivery catheter 40 (e.g. as shown in FIGS. 1A and 1B). An ICE handle may be located at a proximal end of the catheter 270. An ICE array may be located at the distal end of the catheter 270.

[0060] In some embodiments, a separately delivered ultrasound catheter 270 could be functionally linked to the distal end of the delivery catheter 40 and to the inside of the frame 10. The delivery catheter 40 could have mechanical docking and radiopaque features to aid in delivery and stability of the ultrasound catheter 270 relative to the delivery catheter 40.

[0061] FIGS. 3A, 3B, 3C and 3D depict an embodiment of an ICE catheter 300 that may be used with the various implant and delivery devices, systems and methods described herein. The ICE catheter 300 has radial ultrasonic transducers 302, circumferential ultrasonic transducers 304 and guidewire 306 passing centrally therethrough. In some embodiments, there may be one or more radial ultrasonic transducer and/or one or more circumferential ultrasonic transducers. A guidewire lumen 303 extends out from a delivery catheter 240. The delivery catheter 240 may be

analogous to the delivery catheter 40. The ICE catheter 300 extends out through the guidewire lumen 303. FIGS. 3B and 3C show an implant 1 deployed with the ICE catheter 300 tip. The implant 1 may be analogous to the implants 1A, 1B or 1C. FIG. 3C further shows the relationship of the ICE catheter 300 to the delivery catheter 240 while it is taking a radial echo view to properly position the anchor 20 for insertion into heart valve annulus tissue. FIG. 3D shows the ICE catheter 300 capturing a circumferential echo image for properly positioning the frame 10 in a plane above the heart valve and its leaflets. The features shown and described in FIGS. 3A-3D may be used to deliver various other implants, such as other resizing devices or heart valve replacement valves.

[0062] In some embodiments, software or electronic controls can be effective to cycle through the radial cross sectional images around the valve annulus perimeter, relieving the need to physically move, via rotation, translation or deflection, the ICE catheter 300. A larger circumferential transducer array could also be placed distal of the annulus to not interfere with space limitations of the delivery catheter 240, further decreasing the profile of the delivery catheter 240. In another embodiment, the transducers of the ICE catheter 300 could generate a three dimensional image of the annulus of frame 10. The user could then more readily see the relative alignment of the annulus, valve leaflets and the implant 1.

[0063] The implant 1 or other implants may be delivered, positioned and anchored to reshape the valve annulus or replace the entire valve. Particular embodiments of delivery methods are described in detail herein with reference to the figures.

[0064] Generally, the method includes advancing a deployment catheter, such as the delivery catheters described herein, to a deployment site in a heart, with the deployment catheter releasably carrying the implant, such as the implant 1 or other implants including heart valve replacements having valve leaflets. The implant has at least one tissue anchor, such as the anchors described herein. An imaging element, such as the ICE or ultrasound catheters described herein, is positioned in the heart adjacent the implant. A relationship is visualized between the tissue anchor and an anatomical landmark in the heart, and the implant is attached by driving the tissue anchor into tissue in the heart.

[0065] In some embodiments, the method generally includes advancing a distal end of a delivery catheter, such as the delivery catheters described herein, proximate the cardiac valve annulus in the heart. The implant, such as the implant 1 or other implants including heart valve replacements having valve leaflets or Mitral valve leaflet repair devices, is advanced through the distal end of the delivery catheter proximate the cardiac valve annulus. A distal end of an ultrasound catheter, such as the ICE or other ultrasound catheters described herein, is advanced proximate the cardiac valve annulus. The distal end of the ultrasound catheter includes one or more ultrasonic transducers. An ultrasound image is captured, the image being of the implant and the cardiac valve annulus, and captured with the one or more ultrasonic transducers, and the implant is anchored to the cardiac valve annulus. The images may be used to verify the position of, and/or re-position, the anchors before driving the anchors into the cardiac tissue.

[0066] These are general descriptions of some embodiments of methods that may be performed. Particular embodiments of delivering an annulus re-sizing implant are described with respect to FIGS. 4A-4E, and of delivering a heart valve replacement implant are described with respect to FIGS. 5A-5C.

[0067] As shown in FIG. 4A, the implant 1 may be inserted into the heart using a delivery system 401. The implant 1 may be inserted using the delivery system 401 via access to the vasculature of the leg, in particular the femoral vein or the iliac vein. The system 401 may include the various implants, catheters and other features described herein, for example the implant 1, a deployment catheter such as the delivery catheter 240, an imaging element such as the ICE catheter 300 and/or transducers thereon, the guidewire 306, etc. The system 401 may include any of the implants described herein, for example implants including valve annulus reshaping devices or valve replacements that include valve leaflets. The system 401 is then advanced across the septum separating the upper chambers of the heart.

[0068] As shown in FIG. 4B, the imaging element such as the ICE catheter 300 is advanced to a position above the heart valve annulus, for example, the mitral valve annulus. FIG. 4C shows the implant 1 expelled, i.e. deployed, from the distal end of the delivery catheter 240 above and proximate to the mitral valve annulus. In some embodiments, the implant 1 may be deployed before the ICE catheter 300.

[0069] The ICE catheter 300 may be positioned by advancing the ICE catheter 300 transvascularily along a same access path followed by the delivery catheter 240. The ICE catheter 300 may be positioned by advancing the ICE catheter 300 through a lumen in the delivery catheter 240. In some embodiments, the ICE catheter 300 may be positioned by advancing the ICE catheter 300 transvascularily along a different path than that followed by the delivery catheter 240. As further shown in FIG. 4B, the guidewire 306 may extend through the annulus and into the left ventricle.

[0070] In some embodiments, the delivery system 401 may be used to treat the tricuspid valve. For example, the delivery system 401 may be inserted for access through the jugular vein whereby the system 401 is then advanced down the superior vena cava and into the right atrium proximate and above the tricuspid valve annulus.

[0071] In some embodiments, the ICE catheter 300 is positioned by directing the ICE catheter 300 to a predetermined relationship with the deployment catheter 240 using an alignment structure, such as the centering frame 32 or 280. In some embodiments, the ICE catheter 300 is centered within the implant 1 using the alignment structure. In some embodiments, an alignment arm, such as the radial centering arm 34, of the alignment structure is inclined with respect to a longitudinal axis of the deployment catheter 240.

[0072] In some embodiments, the deployment catheter has a central longitudinal axis and the ICE catheter 300, for example the distal end and/or a transducer thereon, is deflected away from the central longitudinal axis. In some embodiments, the method comprises deflecting the ICE catheter 300 in the direction of one or more of the tissue anchors 20. In some embodiments, a first image of a first anchor 20 is captured, the ICE catheter 300 or portion thereof is then repositioned, and then a second image of a second anchor 20 is captured. In some embodiments, the

repositioning step comprises rotating the ICE catheter 300 about an axis. In some embodiments, the repositioning step comprises rotating the ICE catheter 300 about an axis using a rotational drive mechanism. In some embodiments, the repositioning step comprises manually rotating the ICE catheter 300 about the axis. In some embodiments, the ICE catheter 300 carries the imaging element such as a transducer, and the imaging element is rotated, deflected, etc. as described. In some embodiments, a proximal engagement structure on the ICE catheter 300 is locked to a complementary engagement structure on the delivery catheter 240.

[0073] As shown in FIG. 4D, at least one radial image is taken with the ICE catheter 300. A series of radial images may be taken. The radial images are used to properly position the anchors 20 for insertion into the mitral valve annulus tissue. The anchors 20 may be confirmed to be in the proper position, orientation, etc. and driven into the cardiac tissue, for example by rotating the anchors 20. In some embodiments, the implant is attached by driving at least two anchors into tissue in the heart. In some embodiments, the implant is attached by driving at least six anchors into tissue in the heart. In some embodiments, the implant is attached by driving at least eight anchors into tissue in the heart. Other amounts of the anchors may be used as well.

[0074] In some embodiments, the distal end of the ICE catheter 300 is rotated proximate the cardiac valve annulus to a plurality of rotational positions, and a series of ultrasound images are captured of the implant 1 and the cardiac valve annulus at the plurality of rotational positions.

[0075] As shown in FIG. 4E, a circumferential image is captured. In some embodiments, multiple circumferential images may be taken. The circumferential image is taken after the one or more radial images. In some embodiments, the circumferential image may be taken prior to the radial imaging. The circumferential image may be used to confirm that all anchors 20 are appropriately placed and anchored in the mitral valve annulus tissue above the mitral valve leaflets. If one or more anchors 20 are not positioned or anchored properly, they can be manipulated, for example rotationally retracted, repositioned and re-anchored, prior to removal of the driver tubes. In addition, a circumferential image can be taken prior to anchoring to confirm location of the lower crowns 16 of the frame 10 of the implant 1. The radial and/or circumferential images may be used to visualize various anatomical features of the heart, such as the heart valve annulus, the heart valve, valve leaflets, the Mitral valve, the Tricuspid valve, and/or other features. In addition or alternatively, the radial and/or circumferential images may be used to visualize various features of the delivery system 401, such as the implant 1, the anchors 20, etc. The implant 1 may be released from the delivery catheter 240 following capturing the circumferential image.

[0076] FIGS. 5A-5C are sequential perspective views of an embodiment of a delivery system with imaging capability showing an embodiment of a method for the delivery, positioning and anchoring of an artificial or replacement heart valve 700. The methods described with respect to FIGS. 5A-5C of delivering the replacement heart valve 700 may incorporate any of the features of the delivery method described with respect to FIGS. 4A-4E regarding delivery of the implant 1.

[0077] FIGS. 5A-5C show an ultrasound catheter 600 having a guidewire 660 used to guide or assist in the delivery and positioning of the replacement heart valve 700. The

replacement heart valve **700** may be a variety of suitable heart Mitral or Tricuspid heart valve replacements, such as the Edwards Lifesciences Fortis or the Medtronic Twelve transcatheter mitral valve. In some embodiments, the replacement heart valve **700** with valve leaflets may be delivered with the various ultrasound systems described herein. The delivery system is inserted via access to the vasculature of the leg, in particular the femoral vein or the iliac vein. The system is then advanced across the atrial-septal wall separating the upper chambers of the heart, as shown in FIG. **5A**. The ultrasound catheter **600** is advanced to a position above the heart valve annulus, or more specifically, the mitral valve annulus, as shown in FIG. **5B**. FIG. **5C** shows the valve **700** expelled from the delivery catheter across the mitral valve, excluding and replacing the function of the native valve. The method shown in FIGS. **5A-5C** may incorporate other features described herein, such as those described with respect to FIGS. **4A-4E**, for example the various imaging features, various other implants, other access points to the heart, etc.

[**0078**] Relatively large diameter catheter shafts are described herein that may be used to deliver the ring-like implants, such as the implant **1**, or valve replacements, such as the valve **700**, described herein. These large diameter catheter shafts may include features that mitigate or eliminate the tendency to kink, wrinkle or tear when attempting a sharp bend radius. FIGS. **6A** through **9** show various embodiments of sections of steerable catheters that improve the catheter's ability to maneuver tight bends to a position above and proximate and/or into the mitral valve annulus or tricuspid valve annulus.

[**0079**] FIGS. **6A** and **6B** show a steerable catheter **602** in somewhat straight and flexed states, respectively. The steerable catheter **602** may be used in the various delivery systems and methods described herein. The steerable catheter **602** has a distal section **604** and intermediate section **606**. The intermediate section **606** may take the form of a shaft section reinforced with a braid or slotted tubing.

[**0080**] FIGS. **7A** and **7B** depict an embodiment of the distal section **604** that may be used with the steerable catheter **602**, shown in straight and flexed states, respectively. The distal section **604** has a single spine **608** running along its outer curve, and a series of support ribs **610** formed or cut into the inner curve. The distal section **604** may be formed of a flexible metal tube, such as nitinol. The distal section **604** may incorporate pull wires for control of the delivery system. Alternatively, the pull wire may be looped around the distal section's distal tip and back toward the proximal part of the catheter **602**. The support ribs **610**, with voids therebetween, allow the distal section **604** to achieve a tight bend radius. This flexed state of the distal section **604** is realized with minimal protrusion of the support ribs **610** into the inner diameter or outer diameter of the distal section **604**. Moreover, the spine **608** provides a smooth surface on the outer curve of the distal section **604** minimizing friction or interference with heart tissue during delivery and positioning of the catheter and implant.

[**0081**] FIGS. **8A** and **8B** illustrate another embodiment of a distal section **614** that may be used with the steerable catheter **602**. Here, the distal section **614** may be a flexible metal tube that is wrapped or encased in a thin film **612** or polymeric material such as Teflon, pTfe, nylon or other thin material. This thin film **612** encapsulation does not restrict the flexibility of the distal section **614** but does provide for

smoother delivery and transition into and out of a guide catheter. The thin film **612** may be stretchable or designed to fold in on itself, somewhat similar to an accordion, when flexed as shown in FIG. **8B**.

[**0082**] FIG. **9** shows another embodiment of a distal section **624** that may be used with the steerable catheter **602**. Here, distal section **624** comprises a series of larger elements **626** and smaller elements **628**. The smaller elements **628** nest within the larger elements **626**. All elements may slide over one another. When the distal section **624** is in a straight state, the metal elements are most overlapped. As the distal section **624** is actuated towards the flexed state, as shown for example in FIG. **9**, there may be progressively less overlap of the elements particularly on the outer curve of the distal section **624**.

[**0083**] The embodiments of the distal and intermediate sections of the catheter **602** are intended for use in the delivery and implant of both the ring-like embodiments and the replacement valve embodiments described herein. In treating the mitral valve, for example, once the catheter is passed through the septum separating the right and left atria, it is guided slightly upwardly towards the upper reaches of the left atrial chamber. It is then bent significantly in a direction downward towards the mitral annulus, aligning the distal end and the implant with the mitral annulus. The devices, systems and methods described herein allow such bending to occur without kinking or wrinkling which would otherwise impede delivery of the implant.

[**0084**] Various modifications to the implementations described in this disclosure will be readily apparent to those skilled in the art, and the generic principles defined herein can be applied to other implementations without departing from the spirit or scope of this disclosure. Thus, the disclosure is not intended to be limited to the implementations shown herein, but is to be accorded the widest scope consistent with the claims, the principles and the novel features disclosed herein. The word "example" is used exclusively herein to mean "serving as an example, instance, or illustration." Any implementation described herein as "example" is not necessarily to be construed as preferred or advantageous over other implementations, unless otherwise stated.

[**0085**] Certain features that are described in this specification in the context of separate implementations also can be implemented in combination in a single implementation. Conversely, various features that are described in the context of a single implementation also can be implemented in multiple implementations separately or in any suitable sub-combination. Moreover, although features can be described above as acting in certain combinations and even initially claimed as such, one or more features from a claimed combination can in some cases be excised from the combination, and the claimed combination can be directed to a sub-combination or variation of a sub-combination.

[**0086**] Similarly, while operations are depicted in the drawings in a particular order, this should not be understood as requiring that such operations be performed in the particular order shown or in sequential order, or that all illustrated operations be performed, to achieve desirable results. Additionally, other implementations are within the scope of the following claims. In some cases, the actions recited in the claims can be performed in a different order and still achieve desirable results.

[0087] It will be understood by those within the art that, in general, terms used herein are generally intended as “open” terms (e.g., the term “including” should be interpreted as “including but not limited to,” the term “having” should be interpreted as “having at least,” the term “includes” should be interpreted as “includes but is not limited to,” etc.). It will be further understood by those within the art that if a specific number of an introduced claim recitation is intended, such an intent will be explicitly recited in the claim, and in the absence of such recitation no such intent is present. For example, as an aid to understanding, the following appended claims may contain usage of the introductory phrases “at least one” and “one or more” to introduce claim recitations. However, the use of such phrases should not be construed to imply that the introduction of a claim recitation by the indefinite articles “a” or “an” limits any particular claim containing such introduced claim recitation to embodiments containing only one such recitation, even when the same claim includes the introductory phrases “one or more” or “at least one” and indefinite articles such as “a” or “an” (e.g., “a” and/or “an” should typically be interpreted to mean “at least one” or “one or more”); the same holds true for the use of definite articles used to introduce claim recitations. In addition, even if a specific number of an introduced claim recitation is explicitly recited, those skilled in the art will recognize that such recitation should typically be interpreted to mean at least the recited number (e.g., the bare recitation of “two recitations,” without other modifiers, typically means at least two recitations, or two or more recitations). Furthermore, in those instances where a convention analogous to “at least one of A, B, and C, etc.” is used, in general such a construction is intended in the sense one having skill in the art would understand the convention (e.g., “a system having at least one of A, B, and C” would include but not be limited to systems that have A alone, B alone, C alone, A and B together, A and C together, B and C together, and/or A, B, and C together, etc.). In those instances where a convention analogous to “at least one of A, B, or C, etc.” is used, in general such a construction is intended in the sense one having skill in the art would understand the convention (e.g., “a system having at least one of A, B, or C” would include but not be limited to systems that have A alone, B alone, C alone, A and B together, A and C together, B and C together, and/or A, B, and C together, etc.). It will be further understood by those within the art that virtually any disjunctive word and/or phrase presenting two or more alternative terms, whether in the description, claims, or drawings, should be understood to contemplate the possibilities of including one of the terms, either of the terms, or both terms. For example, the phrase “A or B” will be understood to include the possibilities of “A” or “B” or “A and B.”

What is claimed is:

1. A method of anchoring an implant in the heart, comprising:

advancing a deployment catheter to a deployment site in a heart, the deployment catheter releasably carrying an implant having at least one tissue anchor;

positioning an imaging element in the heart adjacent the implant;

visualizing a relationship between the tissue anchor and an anatomical landmark in the heart; and

attaching the implant by driving the tissue anchor into tissue in the heart.

2. The method of claim 1, wherein the positioning an imaging element step comprises advancing the imaging element transvascularily along a same access path followed by the deployment catheter.

3. The method of claim 1, wherein the positioning an imaging element step comprises advancing the imaging element transvascularily along an access path that is different from an access path followed by the deployment catheter.

4. The method of claim 1, wherein the positioning an imaging element step comprises directing the imaging element to a predetermined relationship with the deployment catheter using an alignment structure.

5. The method of claim 4, wherein the imaging element is carried by an imaging catheter and the positioning step comprises centering the imaging catheter within the implant using the alignment structure.

6. The method of claim 5, wherein the centering step comprises inclining at least one alignment arm with respect to a longitudinal axis of the deployment catheter.

7. The method of claim 1, wherein the visualizing step comprises capturing at least one radial image.

8. The method of claim 1, wherein the visualizing step comprises capturing at least one circumferential image.

9. The method of claim 1, wherein the visualizing step comprises visualizing a Mitral valve annulus.

10. The method of claim 9, wherein the attaching an implant step comprises attaching a Mitral valve annulus reshaping device.

11. The method of claim 9, wherein the attaching an implant step comprises attaching a Mitral valve leaflet repair device.

12. The method of claim 9, wherein the attaching an implant step comprises attaching a replacement Mitral valve.

13. The method of claim 1, wherein the attaching an implant step comprises driving at least two anchors into tissue in the heart.

14. The method of claim 1, wherein the attaching step comprises rotating the anchor.

15. The method of claim 13, further comprising the step of capturing a circumferential image following the attaching step.

16. The method of claim 15, further comprising the step of releasing the implant from the deployment catheter following the capturing a circumferential image step.

17. The method of claim 15, further comprising the step of manipulating at least one anchor following the capturing a circumferential image step.

18. The method of claim 1, wherein the deployment catheter has a central longitudinal axis and further comprising the step of deflecting the imaging element away from the central longitudinal axis.

19. The method of claim 13, comprising capturing a first image of a first anchor, repositioning the imaging element, and capturing a second image of a second anchor.

20. A method of delivering an implant proximate a cardiac valve annulus, the method comprising:

advancing a distal end of a delivery catheter proximate the cardiac valve annulus;

advancing the implant through the distal end of the delivery catheter proximate the cardiac valve annulus;

advancing a distal end of an ultrasound catheter proximate the cardiac valve annulus, the distal end of the ultrasound catheter including one or more ultrasonic transducers;

capturing an ultrasound image of the implant and the cardiac valve annulus with the one or more ultrasonic transducers; and

anchoring the implant to the cardiac valve annulus.

21. The method of claim **20**, further comprising:

rotating the distal end of the ultrasound catheter proximate the cardiac valve annulus to a plurality of rotational positions; and

capturing a series of ultrasound images of the implant and the cardiac valve annulus with the one or more ultrasonic transducers at the plurality of rotational positions.

22. The method of claim **20**, wherein the one or more ultrasonic transducers includes a radial ultrasonic transducer, and wherein capturing the series of ultrasound images comprises capturing one or more radial images of the implant and the cardiac valve annulus to properly position anchors of the implant for insertion into the cardiac valve annulus.

23. The method of claim **22**, wherein the one or more ultrasonic transducers includes a circumferential ultrasonic transducer, and wherein capturing the series of ultrasound images further comprises capturing one or more circumferential images of the implant and the cardiac valve annulus.

24. The method of claim **20**, comprising advancing the distal end of the ultrasound catheter proximate the cardiac valve annulus separately from the delivery catheter.

25. The method of claim **24**, comprising advancing the distal end of the ultrasound catheter proximate the cardiac valve annulus through the aortic valve.

26. The method of claim **24**, wherein the ultrasound catheter comprises:

a proximal end having a guidewire entry port;
a distal end having a guidewire exit port; and
a guidewire extending through the entry and exit ports.

27. The method of claim **20**, further comprising centering the ultrasound catheter relative to the implant before capturing the ultrasound image and anchoring the implant.

28. The method of claim **20**, wherein the implant comprises:

a series of struts defining a tubular frame and an axis and forming a plurality of upper and lower crowns;

a plurality of anchors coupled with the lower crowns of the frame and configured to translate axially relative to the frame to engage cardiac tissue proximate the cardiac valve annulus; and

a plurality of collars at least partially surrounding the upper crowns and configured to translate axially relative to the frame to adjust a width of the implant.

29. The method of claim **20**, wherein the implant is a cardiac valve replacement and comprises:

a series of struts defining a tubular frame and an axis and forming a plurality of lower crowns;

a plurality of anchors coupled with the lower crowns of the frame and configured to translate axially relative to the frame to engage cardiac tissue proximate the cardiac valve annulus; and

a plurality of valve leaflets coupled with the frame.

* * * * *

专利名称(译)	使用血管内超声成像递送心脏瓣膜装置的方法		
公开(公告)号	US20170086974A1	公开(公告)日	2017-03-30
申请号	US15/280004	申请日	2016-09-29
[标]申请(专利权)人(译)	米利佩德有限责任公司		
申请(专利权)人(译)	千足虫, INC.		
当前申请(专利权)人(译)	千足虫, INC.		
[标]发明人	LASHINSKI RANDALL KRISTOFFERSEN KRISTIAN RUST MATTHEW GLENN RICHARD LEE MICHAEL MACAULAY PATRICK		
发明人	LASHINSKI, RANDALL KRISTOFFERSEN, KRISTIAN RUST, MATTHEW GLENN, RICHARD LEE, MICHAEL MACAULAY, PATRICK		
IPC分类号	A61F2/24 A61B8/08 A61B8/12 A61B17/064		
CPC分类号	A61F2/2427 A61F2/2412 A61F2/2466 A61B2017/0647 A61B8/0833 A61B8/12 A61B2017/0649 A61B17/064		
优先权	62/234592 2015-09-29 US		
其他公开文献	US10335275		
外部链接	Espacenet USPTO		

摘要(译)

描述了与各种心脏瓣膜植入物的输送相关的方法。可以使用超声成像递送系统递送植入物。超声成像输送系统可用于输送各种不同的装置,包括二尖瓣再成形装置,二尖瓣置换瓣膜等。携带具有组织锚的植入物的展开导管前进到心脏中的展开部位。成像元件定位在植入物附近,并且可视化组织锚和心脏中的解剖学界标之间的关系。然后将组织锚固件驱动到心脏组织中来附接植入物。

