



(19) **United States**

(12) **Patent Application Publication**
Hsieh et al.

(10) **Pub. No.: US 2011/0218423 A1**

(43) **Pub. Date: Sep. 8, 2011**

(54) **WEARABLE ULTRASOUND PROBE ASSEMBLY AND METHOD OF MANUFACTURING SAME**

Publication Classification

(51) Int. Cl.	
<i>A61B 8/00</i>	(2006.01)
<i>A61B 6/03</i>	(2006.01)
<i>A61B 5/055</i>	(2006.01)
<i>G03B 42/02</i>	(2006.01)
<i>B23P 17/04</i>	(2006.01)

(76) Inventors: **Jiang Hsieh**, Brookfield, WI (US); **Michael John Barber**, Mequon, WI (US); **Brian J. Kost**, Waukesha, WI (US); **William R. Clarke**, Colgate, WI (US); **Michael A. Juhl**, Waukesha, WI (US); **Anne Lindsay Hall**, New Berlin, WI (US)

(52) **U.S. Cl. 600/411; 600/459; 600/427; 29/428**

(21) Appl. No.: **13/111,117**

(57) **ABSTRACT**

(22) Filed: **May 19, 2011**

A wearable ultrasound probe apparatus includes a wearable membrane. An ultrasound transducer is also included that is integrated into the wearable membrane and configured to maintain a substantially consistent contact with a surface of an object to be imaged when the object has the wearable membrane disposed thereon.

Related U.S. Application Data

(62) Division of application No. 11/276,195, filed on Feb. 17, 2006.

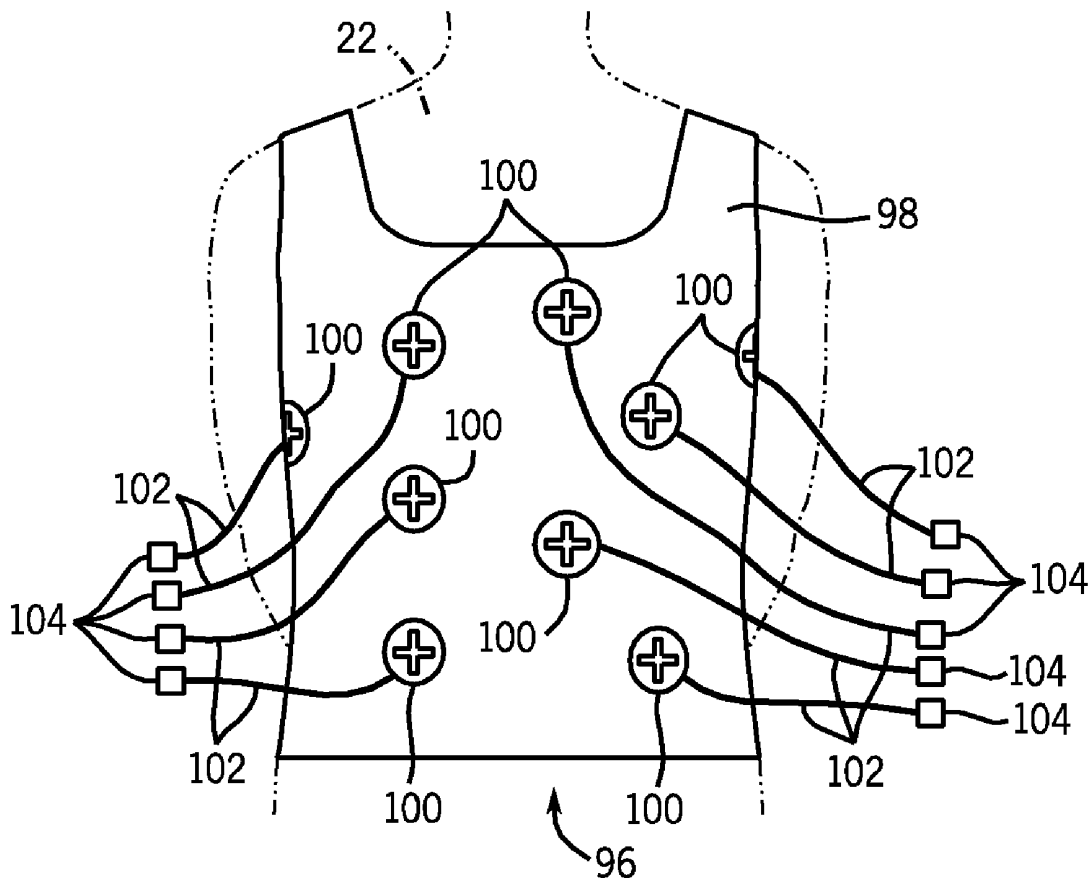

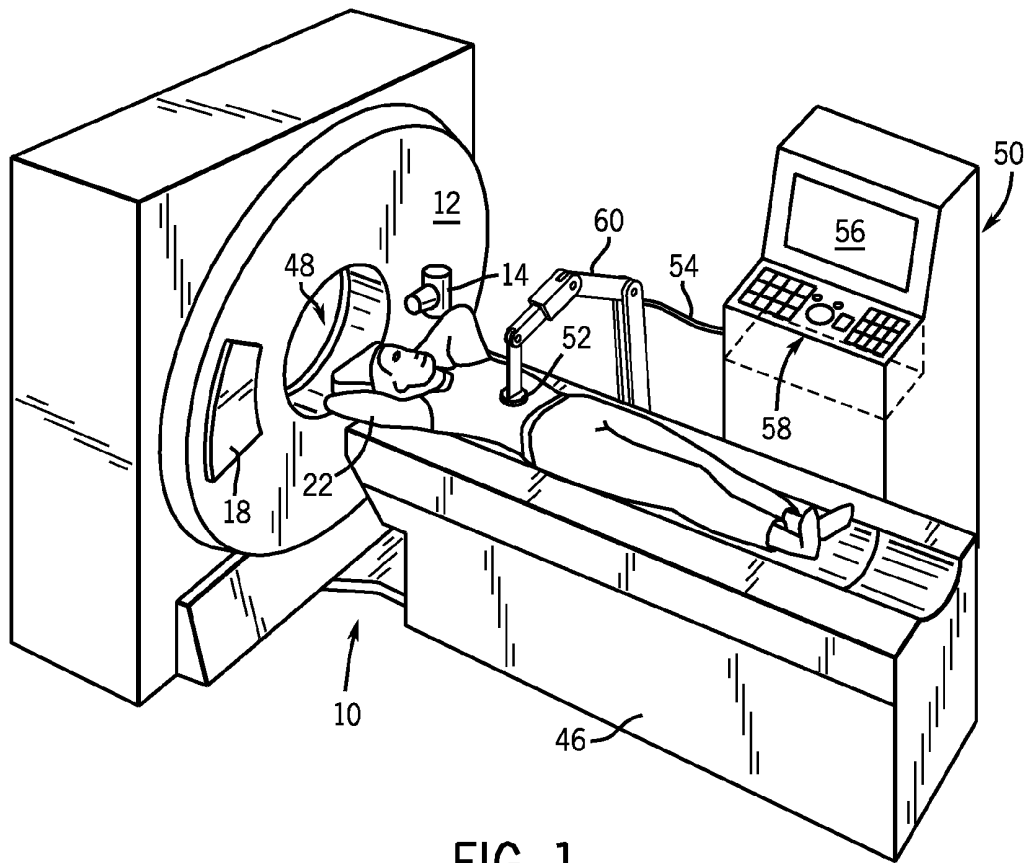

FIG. 1

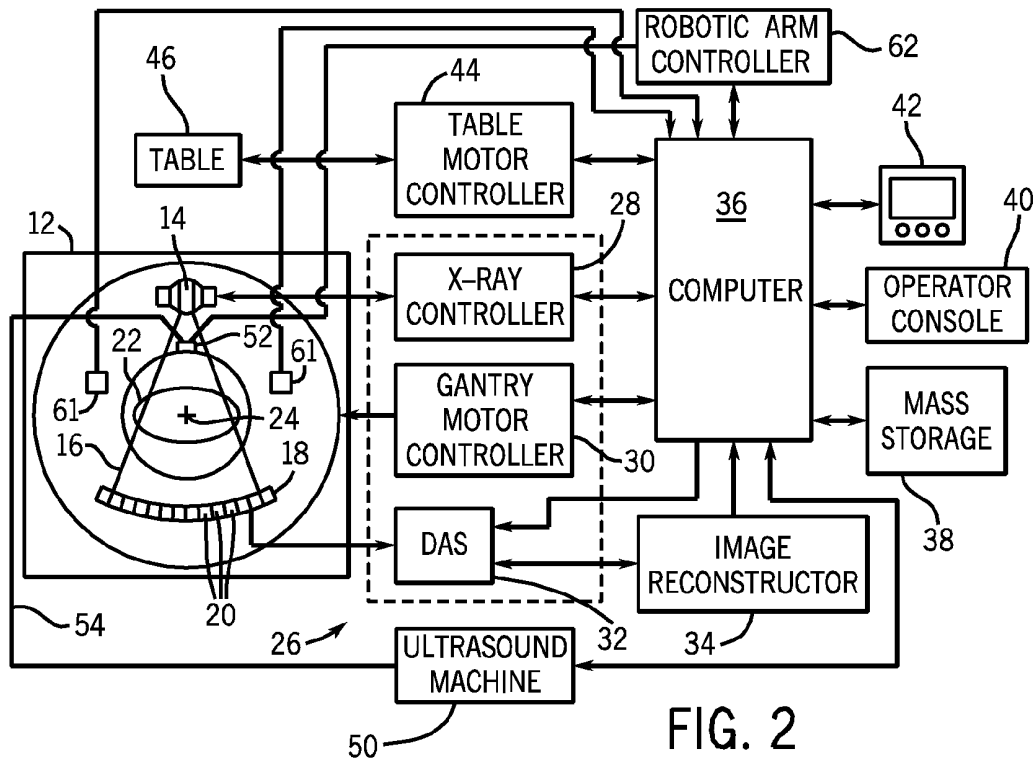

FIG. 2

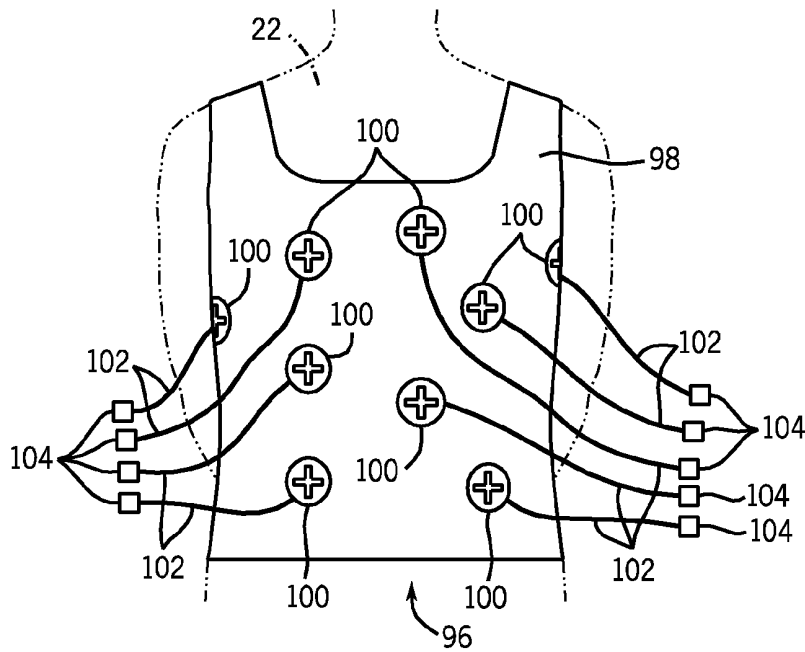

FIG. 5

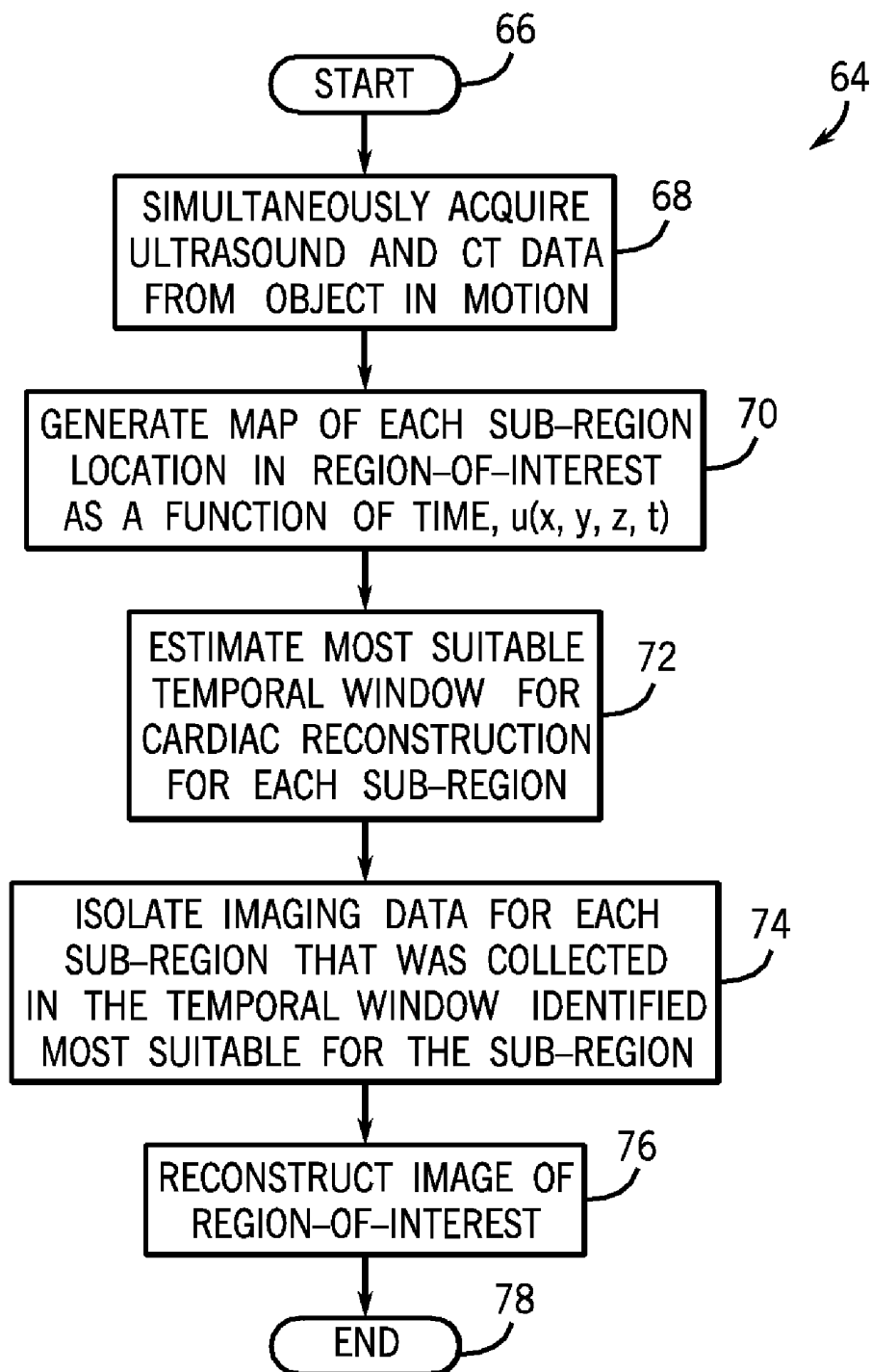

FIG. 3

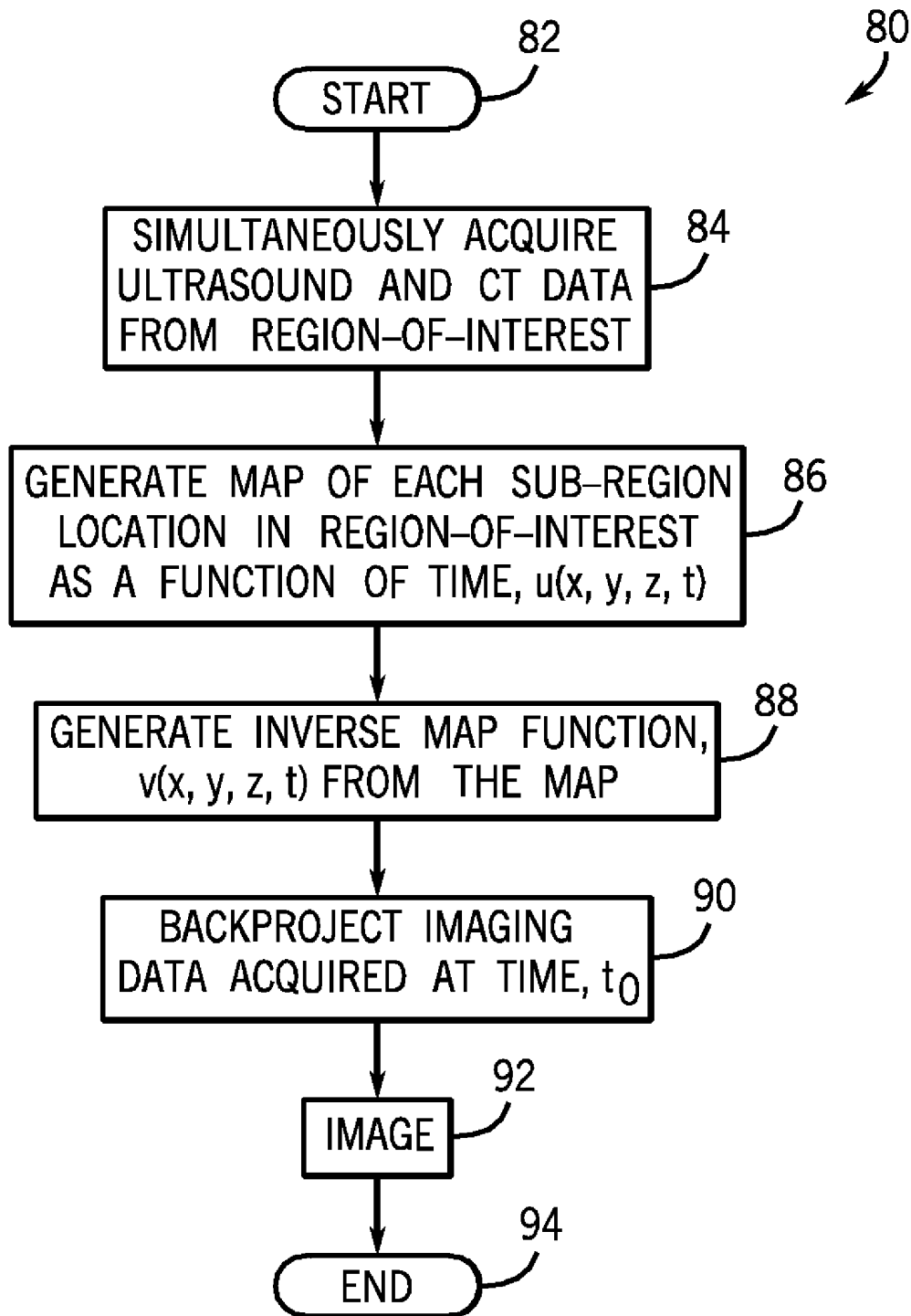

FIG. 4

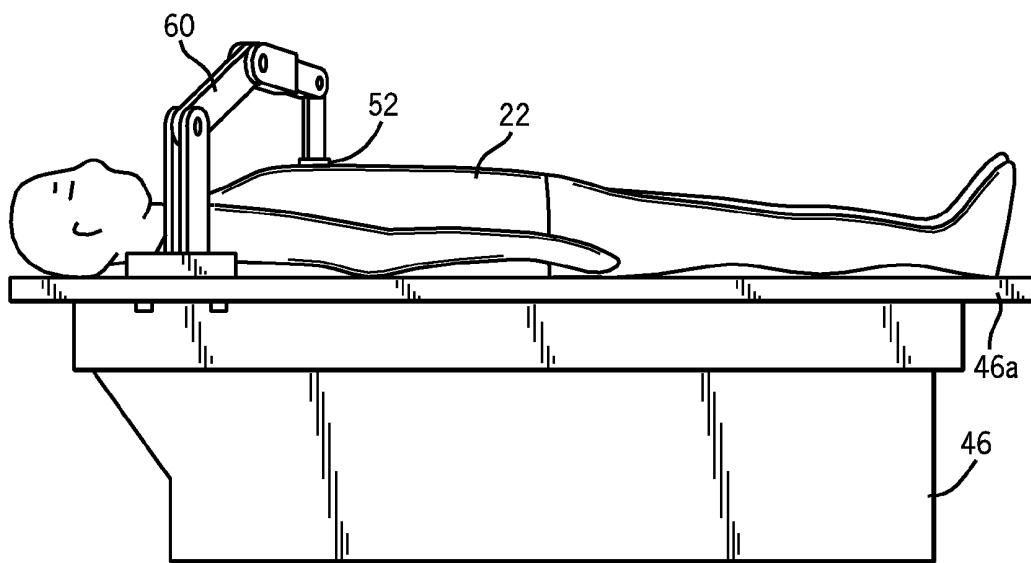

FIG. 6

**WEARABLE ULTRASOUND PROBE
ASSEMBLY AND METHOD OF
MANUFACTURING SAME**

**CROSS-REFERENCE TO RELATED
APPLICATION**

[0001] The present application is a divisional of and claims priority to U.S. Ser. No. 11/276195, filed Feb. 17, 2006, the disclosure of which is incorporated herein by reference.

BACKGROUND OF THE INVENTION

[0002] Embodiments of the present invention relate generally to diagnostic imaging and, more particularly, to a method and apparatus capable of correcting motion errors in imaging data acquired from an object prone to motion. This motion correction is advantageously achieved by using mechanical motion data acquired from the object with one modality coincident with imaging data acquisition from the object with another and different modality.

[0003] Various imaging modalities are often used to image objects in or prone to motion, such as the heart in cardiac studies. For example, in cardiac computed tomography (CT), magnetic resonance imaging (MRI) and other imaging modalities directed to the acquisition of data from an object prone to motion, one or more motion correction techniques are generally used to reduce motion-induced artifacts in the reconstructed images. In known studies, this motion correction or compensation can add significant complexity in post processing of the images.

[0004] In one specific example, CT imaging requires more than 180 degrees of projections to formulate an image. Because of various limitations in conventional CT scanners, the time necessary to collect a complete set of projections is significant relative to object motion. For example, cardiac CT imaging is typically performed with the aid of an electrocardiogram (EKG) signal which is used to synchronize data acquisition and image reconstruction with the phase of cardiac motion. The EKG signal collected from the patient represents the electrical properties of the heart and is helpful in identifying the quiescent period of cardiac activity, which is preferred for data acquisition. Moreover, the EKG signal assists in identifying this quiescent period over several cardiac cycles. By synchronizing data collection with the quiescent period of the cardiac cycle, image artifacts and spatial resolution due to heart motion are reduced. Additionally, by consistently identifying this quiescent period in successive cardiac cycles, inconsistency between images acquired at different cardiac cycles is reduced. EKG signals can be used similarly in MR and other imaging modalities.

[0005] Although this EKG gating performs satisfactorily in most cases, there is room for improvement. Specifically, conventional EKG gating does not provide mechanical motion detection. While an EKG signal can indicate that motion is occurring or is about to occur, it cannot provide accurate real-time placement data of the heart. This is primarily a function of EKG's measuring the electrical activity of the heart and inferring mechanical motion from this electrical activity. As it is the actual mechanical motion of the heart that contributes to sub-optimal image quality, cardiac images that depend on EKG signals either require significant post processing to correct for motion artifacts or require a very high slice acquisition rate.

[0006] That is, CT reconstruction does not have a priori information on heart motion. In conventional EKG gated cardiac CT studies, the heart is presumed to be a stationary object during most of the short acquisition period identified as the quiescent period in the acquired EKG signal. Conventionally, half-scan weighting is used to suppress the impact of motion; however, its effectiveness is less than optimal since half-scan weighting reduces the contribution of CT data acquired at both ends near the 180 degree projection angular range. The amount of data to be suppressed at both ends of the dataset remains constant and therefore does not change based on each data acquisition, since there is no a priori information available. However, the amount of data to be suppressed should change based on the motion characteristics of the scanned object. For data collected roughly in the center of the 180 degree projection angular range, the data is treated in an identical manner without any weighting. Further, even with a gantry speed of 0.3 s/rotation, the central region of the projection range constitutes a 150 ms temporal window, which is prohibitively slow to completely "freeze" cardiac motion. The data acquisition window for CT systems having dual tube-detector assemblies is still between 70-80 ms which is not sufficient to eliminate heart motion. It is generally recognized that 10-15 ms temporal resolution is necessary to acquire a motion-free dataset.

[0007] It would therefore be desirable to design an apparatus and method of acquiring mechanical motion data, rather than inferring mechanical motion data, for physiologically gating CT and other image modality acquisitions to acquire motion-free datasets. It would also be desirable to incorporate the mechanical motion data into the image reconstruction process to compensate for the motion. It would also be desirable to use elasticity and other information obtained from ultrasound to map to the CT images to provide additional functional information, such as the viability of tissue. It would also be desirable to use ultrasound information to assist in identifying calcium in a CT scan and conversely use the CT anatomical information gathered in a CT scan to correct for noise in an ultrasound image. It would also be desirable to use the ultrasound tissue Doppler mode to acquire the velocity map to characterize the wall motion and map it to the CT images to provide functional information.

BRIEF DESCRIPTION OF THE INVENTION

[0008] Embodiments of the present invention are directed to a method and apparatus for simultaneously acquiring imaging data with real-time motion data from an object prone to motion, and using the motion data for motion compensation in the imaging data.

[0009] Motion data is acquired simultaneously and in real-time with image data. The motion data is acquired with a scanner of one modality and provides accurate and near-instant information as to the state and position of an object prone to motion. The image data is acquired with a scanner of a different modality than that used to acquire the motion data. In this regard, embodiments of the present invention are particularly applicable for cardiac CT and MR imaging and other physiologically gated acquisitions. It is also advantageous to overcome peristaltic motion of the patient. In the context of cardiac imaging, the mechanical motion data includes information regarding size, shape, and location of the heart during the cardiac phases (diastole, systole, etc.) during each cardiac cycle. Such detailed information is generally not attainable from EKG signals.

[0010] Therefore, in accordance with one aspect of the present invention, a wearable ultrasound probe apparatus includes a wearable membrane. An ultrasound transducer is also included that is integrated into the wearable membrane and configured to maintain a substantially consistent contact with a surface of an object to be imaged when the object has the wearable membrane disposed thereon.

[0011] In accordance with a further aspect, a wearable ultrasound probe assembly includes an ultrasound transducer array comprising a plurality of ultrasound transducers and a wearable membrane having the plurality of ultrasound transducers disposed thereabout. The wearable membrane is configured to cause the plurality of ultrasound transducers to maintain a substantially consistent contact with a surface of an object to be imaged when the object has the wearable membrane disposed thereon.

[0012] In accordance with another aspect of the present invention, a method of manufacturing a wearable ultrasound probe assembly includes providing a wearable membrane configured to maintain a substantially consistent contact with a surface of an object to be imaged when the object has the wearable membrane disposed thereon. The method also includes coupling a plurality of ultrasound transducers to the wearable membrane.

[0013] Various other features and advantages of the present invention will be made apparent from the following detailed description and the drawings.

BRIEF DESCRIPTION OF THE DRAWINGS

[0014] The drawings illustrate one preferred embodiment presently contemplated for carrying out the invention.

[0015] In the drawings:

[0016] FIG. 1 is a pictorial perspective view of a CT imaging system.

[0017] FIG. 2 is a block schematic diagram of the system illustrated in FIG. 1.

[0018] FIG. 3 is a flowchart setting forth the steps of a motion compensation technique according one aspect of the present invention.

[0019] FIG. 4 is a flowchart setting forth the steps of a modified backprojection technique according to another aspect of the present invention.

[0020] FIG. 5 is a pictorial view of a wearable ultrasound transducer apparatus according to an aspect of the present invention.

[0021] FIG. 6 is a side view of a movable patient table operably connected or integrated with an ultrasound transducer according to another aspect of the invention.

DETAILED DESCRIPTION OF THE PREFERRED EMBODIMENT

[0022] Embodiments of the present invention will be described with respect to a "third generation" CT scanner, but is equally applicable with other image modalities. Moreover, the embodiments of the present invention will be described with respect to an imaging system that includes a CT scanner that acquires image data and an ultrasound machine that acquires motion data from a patient. The CT scanner and ultrasound machine are stand-alone devices that can be used independently from one another, but, as will be described, can operate in tandem to acquire CT data and ultrasound data simultaneously. It is also contemplated that the embodiments of the present invention are applicable with an integrated

CT/ultrasound system. It is further contemplated that the invention may be embodied in a combination ultrasound/MR system or a stand-alone ultrasound and a stand-alone MR scanner that work in tandem to acquire motion and image data.

[0023] Referring to FIGS. 1 and 2, a computed tomography (CT) imaging system 10 is shown as including a gantry 12 representative of a "third generation" CT scanner. Gantry 12 has an x-ray source 14 that projects a beam of x-rays 16 toward a detector array 18 on the opposite side of the gantry 12. Detector array 18 is formed by a plurality of detectors 20 which together sense the projected x-rays that pass through a medical patient 22. Each detector 20 produces an electrical signal that represents the intensity of an impinging x-ray beam and hence the attenuated beam as it passes through the patient 22. During a scan to acquire x-ray projection data, gantry 12 and the components mounted thereon rotate about a center of rotation 24.

[0024] Rotation of gantry 12 and the operation of x-ray source 14 are governed by a control mechanism 26 of CT system 10. Control mechanism 26 includes an x-ray controller 28 that provides power and timing signals to an x-ray source 14 and a gantry motor controller 30 that controls the rotational speed and position of gantry 12. A data acquisition system (DAS) 32 in control mechanism 26 samples analog data from detectors 20 and converts the data to digital signals for subsequent processing. An image reconstructor 34 receives sampled and digitized x-ray data from DAS 32 and performs high speed reconstruction. The reconstructed image is applied as an input to a computer 36 which stores the image in a mass storage device 38.

[0025] Computer 36 also receives commands and scanning parameters from an operator via console 40 that has a keyboard. An associated cathode ray tube display 42 allows the operator to observe the reconstructed image and other data from computer 36. The operator supplied commands and parameters are used by computer 36 to provide control signals and information to DAS 32, x-ray controller 28 and gantry motor controller 30. In addition, computer 36 operates a table motor controller 44 which controls a motorized table 46 to position patient 22 and gantry 12. Particularly, table 46 moves portions of patient 22 through a gantry opening 48.

[0026] Still referring to FIGS. 1-2, in an exemplary embodiment, an ultrasound machine 50 having one or more ultrasound transducers 52 linked thereto by control and read-out cable 54 is used to acquire mechanical motion data coincident with the acquisition of imaging data. The ultrasound machine includes a printer (not shown) for printing images displayed on monitor 56 as well as a keyboard and other input devices 58 to carry out an ultrasound study. In a preferred embodiment, the ultrasound machine is remotely positioned from the patient 22 and located at or near the operator console 40 of the CT scanner.

[0027] As will be described more fully below, the combined imaging system includes a robot arm 60 that controls positioning of the ultrasound transducer 52. The robot arm 60 is controlled by a robot arm controller 62 that is operably linked to the computer 36 or ultrasound machine 50.

[0028] Embodiments of the present invention are directed to a method and apparatus of simultaneously acquiring motion data of an object in motion and imaging data of that object. The mechanical motion data is used for motion correction or compensation of the imaging data. Preferably, the mechanical motion data is acquired with an ultrasound trans-

ducer. Ultrasound is preferred because it is a real-time imaging modality. Ultrasound provides accurate and near-instant information on the mechanical state of an object in motion, such as the heart. Since the ultrasound image depicts a cross-section of the object, rather than projection or integrated views, ultrasound imaging supplies sufficient information on object motion characteristics. For example, in the context of cardiac imaging, ultrasound can provide real-time information as to the size, shape, and location of the heart when it is in diastole, systole, or other phase of the cardiac cycle. As will be described, this advantage of ultrasound is exploited by simultaneously acquiring an ultrasound dataset and an imaging (such as CT) dataset, and using the ultrasound dataset for information on the shape and location of the heart to reduce motion induced artifacts in the imaging data set.

[0029] Accordingly, referring now to FIG. 3, a flowchart setting forth steps of one exemplary technique for motion compensation is shown. The technique **64** begins at **66** with the simultaneous acquisition **68** of mechanical motion and imaging data from a volume of interest having an object experiencing motion therein. For purposes of illustration, the technique will be described with respect to the acquisition of the mechanical motion data of a heart using ultrasound and the acquisition of imaging data from the heart using CT.

[0030] The ultrasound data acquired at **68** provides near-instant information on the mechanical state of the heart. As such, cardiac motion of the heart under inspection is known from the ultrasound data. The technique then uses this knowledge of cardiac motion to generate a map that describes each voxel (sub-volume) of the heart volume as a function of time **70**. Generally, the map can be characterized as a four dimensional function, $u(x,y,z,t)$, where (x,y,z) represents the coordinate of a reconstructed voxel in the heart volume, and t represents time.

[0031] Since the map provides an indication of each voxel or sub-volume of the heart volume as a function of time, the optimal temporal window for reconstruction for each voxel may be readily determined **72**. This is particularly advantageous for cardiac CT imaging as it is well-known that different portions of the heart move differently. For example, the optimal temporal window to effectively freeze motion in the right ventricle of the heart is different than the optimal temporal window to effectively freeze motion in the right coronary.

[0032] The cone-parallel geometry reconstruction algorithm can be described as:

$$f(x, y, z) = \int_0^{\pi} \frac{R \cdot w(x, y, z, \beta)}{\sqrt{R^2 + Z^2}} \hat{s}(\alpha, \beta, t) d\beta, \quad (\text{Eqn. 1})$$

where:

$$\hat{s}(\alpha, \beta, t) = s(\alpha, \beta, t) \otimes h(t). \quad (\text{Eqn. 2})$$

[0033] Here, $w(x, y, z, \beta)$ is a weighting function that controls the contribution of the projection to each voxel, and π is the projection angular range required for reconstruction. One skilled in the art will appreciate that the weighting function shapes the temporal window for each voxel or sub-volume. In this regard, the technique effectively determines a temporal window best suited for freezing motion in the imaging volume on a per-voxel basis. As such, the technique isolates imaging data for each voxel **74** that falls within the temporal

window determined for the voxel at **72**. An image for the heart volume is then reconstructed in accordance with known reconstruction techniques at **76**.

[0034] The reconstructed image is substantially free of motion artifacts as the ultrasound data acquired simultaneously with the imaging data has been used to effectively determine a temporal window on a per-voxel basis. In this regard, motion is effectively “frozen” in each voxel of the heart volume. By reconstructing an image wherein each voxel contains motion free data, the image, as a whole, will also be free of motion. Following image reconstruction, the technique ends at **78**.

[0035] Referring now to FIG. 4, the information garnered from the mapping function, $u(x,y,z,t)$, may be used in the backprojection process to correct for errors caused by cardiac motion. It is contemplated that the technique of FIG. 4 may be carried out independently or in conjunction with the technique of FIG. 3. For purposes of illustration, the technique of FIG. 4 will be described independently. In this regard, technique **80** begins at **82** with the simultaneous acquisition of ultrasound and imaging data at **84**. A 4D map that provides an indication of the coordinate transformation as a function of time for each voxel of the heart volume is generated at **86**. The ultrasound information, as noted above, can then be used during backprojection to correct for motion errors.

[0036] To this end, an inverse mapping function, $v(x,y,z,t)$, which translates each voxel at time t back to voxel location at a specific reference time t_0 , is generated at **88**. This inverse mapping supplements the cone beam backprojection process **90**, as defined by the following expression:

$$f(x, y, z) = \int_0^{\pi} w(x, y, z, \beta) \times v \left[\frac{R}{\sqrt{R^2 + Z^2}} \hat{s}(\alpha, \beta, t) \right] d\beta, \quad (\text{Eqn. 3})$$

where:

$$\hat{s}(\alpha, \beta, t) = s(\alpha, \beta, t) \otimes h(t). \quad (\text{Eqn. 4})$$

[0037] It should be noted that the weighting function, $w(x, y, z, \beta)$, in Eqn. 3 is different from the weighting function in Eqn. 1. The weighting function of Eqn. 3 represents a “confidence” weighting based on the degree of certainty that is placed on the belief that the inverse mapping function properly characterizes heart motion.

[0038] Still referring to FIG. 4, the backprojection process yields an image **92** whereupon the technique ends at **94**. By taking advantage of the inverse map, the resulting image is a true image of the state of the heart at time t_0 .

[0039] In addition to motion correction, the acquisition of complementary ultrasound and imaging data can also be used to assess the viability of tissues. That is, the ultrasound data can be used to generate an elasticity map. This elasticity map, in conjunction with the imaging data, can be used in conjunction with CT perfusion data to provide information regarding tissue viability. Specifically, the ultrasound and CT images can be fused together to provide a cardiac viability map. This is particularly advantageous in reducing radiation dose to a patient relative to conventional approaches in determining cardiac viability.

[0040] In conventional CT perfusion studies, the heart volume of a patient is scanned repeatedly to acquire functional information. This repeated data acquisition from the patient

translates to significant levels of x-ray dose to the patient. However, with the embodiments of the present invention, because the ultrasound data is acquired coincident with the imaging data, the ultrasound data may be used to identify the viability of tissue. As a result, the customary repeated scans may be replaced by a single or a few scans, which yields a significant dose reduction. This dose reduction allows the single or few scans to be carried out at higher dose levels which increases SNR and CNR in the resulting images.

[0041] Moreover, the complimentary ultrasound and imaging data can be used to improve the detection and classification of plaques. Typically, several scans are required to classify a given plaque. The embodiments of the present invention reduce the need for such numerous scans, which provides a dose reduction for such studies.

[0042] In a further embodiment of the invention, the complimentary ultrasound and imaging data is used for image noise reduction. Specifically, the ultrasound data provides additional boundary and anatomical information to supplement that gathered with CT. As such, during application of noise reduction algorithms, more information is known as to the structure of the tissue. In this regard, noise reduction can be carried out without impacting small anatomical structures that were identified with the ultrasound images but undetected or partially detected with CT.

[0043] The simultaneous acquisition of ultrasound and imaging data, i.e., CT data, is also effective in reducing "calcium blooming" and separating calcium from iodine or other marker. More particularly, the ultrasound images are used to further demarcate calcium from the iodine marker in the volume being imaged. Specifically, the ultrasound reflection of calcium is significantly different than the ultrasound reflection of iodine. As such, these reflection differences can be readily identified using ultrasound which aids in detecting the corresponding calcium deposits or plaques in the CT images.

[0044] Although the embodiments of the present invention has been described with respect to cardiac CT studies, one skilled in the art will appreciate that the embodiments of the present invention can be applied to correct other physiologically induced motion.

[0045] For example, it is well known that CT images can be corrupted by the peristaltic motion of the patient. Conventional compensation techniques utilize a fixed weighting function to suppress contributions of the projection samples at both ends of the datasets. This approach has two shortcomings. The first is the increased noise and the second is the lack of effectiveness when the motion is large. With the ultrasound information, the weighting function can be modified based on the motion characteristics or the backprojection process can be changed to compensate for the motion. For example, when little motion is present, the weighting function can be nearly constant to minimize the noise. When the motion increases, the "underscan angle" can be increased accordingly to reduce the motion artifacts.

[0046] It is also understood that the motion compensation techniques described above, in the context of CT, can be used to reduce the requirements on acquisition speed. In conventional cardiac CT studies, the gantry rotation speed is typically 0.35 s per rotation. This places significant constraints on the mechanical, detector, and tube design. If the gantry speed can be reduced to 0.5 s while maintaining the same image quality, the CT system design can be simplified. Additionally, since the complimentary ultrasound data can be used to more fully characterize heart motion, the need for short scan times

is reduced with the embodiments of the present invention. For example, it is recognized that the embodiments of the present invention enable heart studies to be conducted with a four-slice scanner that otherwise requires a 64-slice scanner, for example.

[0047] Referring back to FIGS. 1-2, in one embodiment to simultaneously acquire ultrasound and CT images without a technician moving the transducer, the ultrasound transducer **52** is robotically controlled by the robot arm **60**. This allows for positioning of the transducer without operator presence in or near the imaging bore **48**. In a preferred embodiment, the robot arm **60** is telescoping and therefore moves the transducer freely about the patient during data acquisition and/or during indexing of the patient through the bore. Preferably, the robot arm is controlled by the robot arm controller **62** that positions and controls the robot arm based on positioning controls manifested in user-inputs to the ultrasound machine **50** or, alternatively, the CT scanner operator console **40**. It is also contemplated that the robotic arm may be automatically controlled based on user-inputs identifying those regions of the patient where it is desired to acquire ultrasound data. It is also contemplated that a robotic arm may be controlled by a user making arm and hand movements that are sensed by a sensory array, and processed and transmitted as control commands to the robotic arm that cause the robotic arm to simulate the arm and hand movements of the user in near real-time. Alternatively, as shown in FIG. 6, the ultrasound probe can be integrated with the patient table **46(a)** such that the probe **52** and patient **22** remain relatively stationary even when the patient **22** is indexed to different locations to scan different portions of the anatomy.

[0048] It is preferred that the ultrasound transducer and the robotic arm be fabricated so as to limit the metallic content thereof. By reducing the metallic content of the transducer or probe and the robotic arm, artifacts attributable to these devices in the reconstructed images are reduced. Furthermore, in one exemplary embodiment, the position of the ultrasound transducer is automatically determined and is used to register the acquired ultrasound images with the CT images. In this regard, it is contemplated that the ultrasound transducer may be included in a GPS network (not shown) that provides positional and orientation feedback to the ultrasound machine and/or CT scanner for image registration. It is also contemplated that various sensors, such as infrared sensors or laser positioning devices **61**, FIG. 2, may be used to provide transducer position feedback to ultrasound machine **50** or CT computer **36**.

[0049] In an alternate embodiment, ultrasound data is acquired with a plurality of ultrasound transducers integrally formed with a wearable membrane, as illustrated in the wearable ultrasound probe assembly **96** shown in FIG. 5. The assembly **96** is constructed to allow imaging through the membrane and without appreciable noise in resulting images by a medical imaging scanner. As illustrated, the wearable membrane **98** includes ultrasound transducers **100** that are disposed about the wearable membrane **98**. The wearable assembly is designed to be worn by a patient **22**. In this regard, the wearable assembly **96** can be worn by the patient when the patient is not positioned on an imaging table. Each ultrasound transducer produces an ultrasonic beam and acquires ultrasound data from the patient. Each transducer has a readout lead **102** with a quick-connect jumper **104**. The quick-connect jumpers **104** allow the assembly or jacket to be quickly connected/disconnected from the ultrasound machine. It is

also contemplated that each readout lead may be routed through the wearable membrane to a common multi-pin port (not shown) so that a single cable (not shown) can be used to connect the transducers to the ultrasound machine.

[0050] It is contemplated that the transducers can be collectively or independently controlled. In this regard, it is contemplated that one transducer may be enabled for data collection whereas another transducer is disabled. It is contemplated that the wearable assembly may take the form of a vest, belt, wrap, or other article. In any event, it is preferred that the membrane be snugly fit to the patient to ensure that the transducers are in contact with the skin of the patient. Accordingly, it is contemplated that the membrane may be formed of elastic material so that one size fits all or multiple sized membranes may be used to accommodate variations in patient population.

[0051] Preferably, the wearable membrane is formed of non-metallic material, such as fabric. It is also preferred the membrane being relatively comfortable for the patient. One skilled in the art will appreciate that the principles of the wearable assembly shown and described with respect to FIG. 5 may be adopted to be more appropriately shaped for other anatomical regions of the patient. It is also preferred that the wearable membrane include a sufficient number of transducers so that desired structures may be imaged without requiring repositioning of the membrane on the patient.

[0052] Therefore, in accordance with one embodiment of the present invention, a wearable ultrasound probe apparatus includes a wearable membrane. An ultrasound transducer is also included that is integrated into the wearable membrane and configured to maintain a substantially consistent contact with a surface of an object to be imaged when the object has the wearable membrane disposed thereon.

[0053] In accordance with a further embodiment, a wearable ultrasound probe assembly includes an ultrasound transducer array comprising a plurality of ultrasound transducers and a wearable membrane having the plurality of ultrasound transducers disposed thereabout. The wearable membrane is configured to cause the plurality of ultrasound transducers to maintain a substantially consistent contact with a surface of an object to be imaged when the object has the wearable membrane disposed thereon.

[0054] In accordance with another embodiment of the present invention, a method of manufacturing a wearable ultrasound probe assembly includes providing a wearable membrane configured to maintain a substantially consistent contact with a surface of an object to be imaged when the object has the wearable membrane disposed thereon. The method also includes coupling a plurality of ultrasound transducers to the wearable membrane.

[0055] This written description uses examples to disclose the invention, including the best mode, and also to enable any person skilled in the art to practice the invention, including making and using any devices or systems and performing any incorporated methods. The patentable scope of the invention is defined by the claims, and may include other examples that occur to those skilled in the art. Such other examples are intended to be within the scope of the claims if they have structural elements that do not differ from the literal language of the claims, or if they include equivalent structural elements with insubstantial differences from the literal languages of the claims.

What is claimed is:

1. A wearable ultrasound probe apparatus comprising: a wearable membrane; and an ultrasound transducer integrated into the wearable membrane and configured to maintain a substantially consistent contact with a surface of an object to be imaged when the object has the wearable membrane disposed thereon.
2. The apparatus of claim 1 wherein the membrane is constructed to allow imaging therethrough and without appreciable noise to resulting images by a medical imaging scanner.
3. The apparatus of claim 1 wherein the wearable membrane is formed of non-metallic material.
4. The apparatus of claim 3 wherein the non-metallic material is fabric.
5. The apparatus of claim 1 further comprising a plurality of ultrasound transducers integrated into the wearable membrane.
6. The apparatus of claim of claim 1 wherein the ultrasound transducer is a hands-free device.
7. The apparatus of claim 1 wherein the ultrasound transducer is substantially free of image-artifact inducing material.
8. The apparatus of claim 7 wherein the ultrasound transducer is configured to acquire ultrasound data simultaneously with acquisition of imaging data, the imaging data acquired with one of a CT machine, an x-ray machine, an MR machine, and a PET machine.
9. A wearable ultrasound probe assembly comprising: an ultrasound transducer array comprising a plurality of ultrasound transducers; and a wearable membrane having the plurality of ultrasound transducers disposed thereabout; wherein the wearable membrane is configured to cause the plurality of ultrasound transducers to maintain a substantially consistent contact with a surface of an object to be imaged when the object has the wearable membrane disposed thereon.
10. The apparatus of claim 9 wherein the membrane is constructed to allow imaging therethrough and without appreciable noise to resulting images by a medical imaging scanner.
11. The apparatus of claim 9 wherein the wearable membrane is formed of non-metallic material.
12. The apparatus of claim 11 wherein the non-metallic material is fabric.
13. The apparatus of claim 9 further comprising: a plurality of readout leads coupled to the plurality of ultrasound transducers; and a plurality of quick-connect jumpers coupled to the plurality of readout leads, wherein the plurality of quick-connect jumpers is configured to quickly connect the plurality of readout leads to an ultrasound machine.
14. The apparatus of claim of claim 9 wherein the plurality of ultrasound transducers is independently controllable such that less than all of the plurality of ultrasound transducers may be enabled for data collection.
15. The apparatus of claim 9 wherein the wearable membrane comprises one of a vest, a belt, and a wrap.
16. The apparatus of claim 15 wherein the wearable membrane is configured to cause the plurality of ultrasound transducers to maintain a substantially consistent contact with a skin of the object.
17. A method of manufacturing a wearable ultrasound probe assembly comprising:

providing a wearable membrane configured to maintain a substantially consistent contact with a surface of an object to be imaged when the object has the wearable membrane disposed thereon; and
coupling a plurality of ultrasound transducers to the wearable membrane.

18. The method of claim **17** wherein providing the wearable membrane comprises providing an elastic membrane.

19. The method of claim **17** wherein coupling the plurality of ultrasound transducers to the wearable membrane comprises coupling a plurality of ultrasound transducers such that

a desired structure of the object may be imaged without requiring repositioning of the membrane on the object.

20. The method of claim **17** further comprising:
coupling a plurality of readout leads to the plurality of ultrasound transducers; and

coupling a plurality of quick-connect jumpers to the plurality of readout leads, wherein the plurality of quick-connect jumpers is configured to quickly connect the plurality of readout leads to an ultrasound machine.

* * * * *

专利名称(译)	可穿戴式超声探头组件及其制造方法		
公开(公告)号	US20110218423A1	公开(公告)日	2011-09-08
申请号	US13/111117	申请日	2011-05-19
[标]申请(专利权)人(译)	HSIEH姜 BARBER迈克尔·约翰· KOST BRIAN J CLARKE WILLIAM - [R JUHL迈克尔 HALL ANNE LINDSAY		
申请(专利权)人(译)	HSIEH姜 BARBER迈克尔·约翰· KOST BRIAN J CLARKE WILLIAM - [R JUHL迈克尔 HALL ANNE LINDSAY		
当前申请(专利权)人(译)	HSIEH姜 BARBER迈克尔·约翰· KOST BRIAN J CLARKE WILLIAM - [R JUHL迈克尔 HALL ANNE LINDSAY		
[标]发明人	HSIEH JIANG BARBER MICHAEL JOHN KOST BRIAN J CLARKE WILLIAM R JUHL MICHAEL A HALL ANNE LINDSAY		
发明人	HSIEH, JIANG BARBER, MICHAEL JOHN KOST, BRIAN J. CLARKE, WILLIAM R. JUHL, MICHAEL A. HALL, ANNE LINDSAY		
IPC分类号	A61B8/00 A61B6/03 A61B5/055 G03B42/02 B23P17/04		
CPC分类号	A61B5/0073 Y10T29/49826 A61B5/1075 A61B5/6805 A61B5/721 A61B5/7285 A61B6/032 A61B6/503 A61B6/5247 A61B8/08 A61B8/0858 A61B8/0883 A61B8/42 A61B8/4218 A61B8/4281 A61B8/4416 A61B8/485 A61B19/2203 A61B19/5244 A61B2017/00694 A61B2017/00991 A61B2019/5236 A61B2019 /524 A61B2019/5263 A61B2019/5276 G01T1/1603 G01T1/1648 A61B6/4417 A61B5/02007 A61B34/20 A61B34/30 A61B2034/2063 A61B2090/374 A61B2090/3762 A61B2090/378		
外部链接	Espacenet USPTO		

摘要(译)

可穿戴超声探头设备包括可穿戴膜。还包括超声换能器，其被集成到可穿戴膜中并且被配置为当物体具有设置在其上的可穿戴膜时保持与待成像物体的表面基本一致的接触。

