



US010335275B2

(12) **United States Patent**  
**Lashinski et al.**

(10) **Patent No.:** **US 10,335,275 B2**  
(45) **Date of Patent:** **Jul. 2, 2019**

(54) **METHODS FOR DELIVERY OF HEART VALVE DEVICES USING INTRAVASCULAR ULTRASOUND IMAGING**

(58) **Field of Classification Search**  
CPC .... A61F 2/2427; A61F 2/2466; A61F 2/2412;  
A61B 8/455; A61B 8/085; A61B 8/0841;  
(Continued)

(71) Applicant: **MILLIPEDE, INC.**, Santa Rosa, CA (US)

(56) **References Cited**

(72) Inventors: **Randall Lashinski**, Windsor, CA (US);  
**Kristian Kristoffersen**, Redding, CA (US);  
**Matthew Rust**, Windsor, CA (US);  
**Richard Glenn**, Santa Rosa, CA (US);  
**Michael Lee**, Santa Rosa, CA (US);  
**Patrick Macaulay**, Windsor, CA (US)

U.S. PATENT DOCUMENTS

3,143,742 A 8/1964 Cromie  
4,042,979 A 8/1977 Angell  
(Continued)

(73) Assignee: **MILLIPEDE, INC.**, Santa Rosa, CA (US)

FOREIGN PATENT DOCUMENTS

EP 0 624 080 12/2001  
EP 2 047 824 5/2012  
(Continued)

(\* ) Notice: Subject to any disclaimer, the term of this patent is extended or adjusted under 35 U.S.C. 154(b) by 108 days.

OTHER PUBLICATIONS

International Search Report dated Oct. 8, 2015 in PCT/US2015/040622.

(21) Appl. No.: **15/280,004**

(Continued)

(22) Filed: **Sep. 29, 2016**

*Primary Examiner* — Julian W Woo

(65) **Prior Publication Data**

US 2017/0086974 A1 Mar. 30, 2017

**Related U.S. Application Data**

(63) Continuation of application No. 62/234,592, filed on Sep. 29, 2015.

(57) **ABSTRACT**

Methods related to delivery of various heart valve implants are described. The implant may be delivered using an ultrasound imaging delivery system. The ultrasound imaging delivery system may be used to deliver a variety of different devices, including mitral valve reshaping devices, mitral valve replacement valves, and others. A deployment catheter carrying an implant having a tissue anchor is advanced to a deployment site in a heart. An imaging element is positioned adjacent the implant and a relationship between the tissue anchor and an anatomical landmark in the heart is visualized. The implant is then attached by driving the tissue anchor into tissue in the heart.

(51) **Int. Cl.**  
*A61F 2/24* (2006.01)  
*A61B 17/064* (2006.01)  
(Continued)

**31 Claims, 23 Drawing Sheets**

(52) **U.S. Cl.**  
CPC ..... *A61F 2/2427* (2013.01); *A61B 8/085* (2013.01); *A61B 8/0841* (2013.01);  
(Continued)

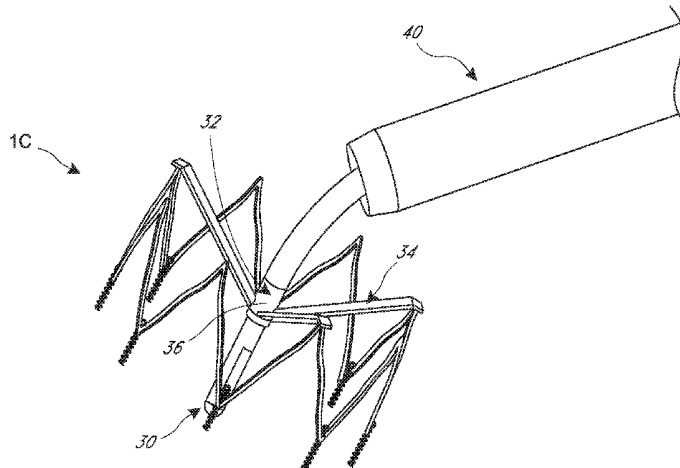

(51)	<b>Int. Cl.</b>		7,329,278 B2	2/2008	Seguin et al.	
	<i>A61B 8/08</i>	(2006.01)	7,329,280 B2	2/2008	Bolling et al.	
	<i>A61B 8/12</i>	(2006.01)	7,335,213 B1	2/2008	Hyde et al.	
	<i>A61B 8/00</i>	(2006.01)	7,357,815 B2	4/2008	Shaoulian et al.	
(52)	<b>U.S. Cl.</b>		7,361,190 B2	4/2008	Shaoulian et al.	
	CPC .....	<i>A61B 8/0883</i> (2013.01); <i>A61B 8/12</i>	7,381,218 B2	6/2008	Schreck	
		(2013.01); <i>A61B 8/445</i> (2013.01); <i>A61B</i>	7,404,824 B1	7/2008	Webler et al.	
		<i>17/064</i> (2013.01); <i>A61F 2/2412</i> (2013.01);	7,455,690 B2	11/2008	Cartledge et al.	
		<i>A61F 2/2466</i> (2013.01); <i>A61B 2017/0647</i>	7,482,936 B2	1/2009	Bolling	
		(2013.01); <i>A61B 2017/0649</i> (2013.01)	7,485,142 B2	2/2009	Milo	
(58)	<b>Field of Classification Search</b>		7,507,252 B2	3/2009	Lashinski et al.	
	CPC .....	A61B 8/0883; A61B 8/12; A61B 17/064;	7,527,646 B2	5/2009	Randert et al.	
		A61B 2017/0647; A61B 2017/0649	7,534,204 B2 *	5/2009	Starksen .....	A61B 17/00234
	USPC .....	623/2.11				600/116
	See application file for complete search history.					
(56)	<b>References Cited</b>					
	U.S. PATENT DOCUMENTS					
	4,290,151 A	9/1981 Massana				
	4,602,911 A	7/1986 Ahmadi et al.				
	4,820,299 A	4/1989 Philippe et al.				
	5,064,431 A	11/1991 Gilbertson et al.				
	5,254,127 A	10/1993 Wholey et al.	7,887,582 B2	2/2011	Mathis et al.	
	5,370,685 A	12/1994 Stevens	7,896,913 B2	3/2011	Damm et al.	
	5,674,279 A	10/1997 Wright et al.	7,914,576 B2	3/2011	Navia et al.	
	5,674,280 A	10/1997 Davidson et al.	7,914,577 B2	3/2011	Cox	
	5,769,816 A	6/1998 Barbut et al.	7,927,371 B2	4/2011	Navia et al.	
	5,772,590 A	6/1998 Webster, Jr.	7,935,145 B2	5/2011	Alfieri et al.	
	5,810,882 A	9/1998 Bolduc	7,959,673 B2	6/2011	Carpentier et al.	
	5,824,066 A	10/1998 Gross	7,972,378 B2	7/2011	Tabor et al.	
	5,968,053 A	10/1999 Revelas	7,988,725 B2	8/2011	Gross et al.	
	5,984,959 A	11/1999 Robertson et al.	7,993,395 B2	8/2011	Vanermen et al.	
	6,001,127 A	12/1999 Schoon et al.	8,012,202 B2	9/2011	Alameddine	
	6,059,731 A	5/2000 Seward et al.	8,016,877 B2	9/2011	Seguin et al.	
	6,074,418 A	6/2000 Buchanan et al.	8,052,751 B2	11/2011	Aklog et al.	
	6,176,877 B1	1/2001 Buchanan et al.	8,128,641 B2	3/2012	Wardle	
	6,210,432 B1	4/2001 Solem et al.	8,142,494 B2	3/2012	Randert et al.	
	6,254,642 B1	7/2001 Taylor	8,142,496 B2	3/2012	Berrekouw	
	6,355,030 B1	3/2002 Aldrich et al.	8,157,853 B2	4/2012	Laske et al.	
	6,402,780 B2	6/2002 Williamson et al.	8,163,013 B2	4/2012	Machold et al.	
	6,582,460 B1	6/2003 Cryer	8,182,528 B2	5/2012	Salahieh et al.	
	6,629,534 B1	10/2003 Deem et al.	8,187,207 B2	5/2012	Machold et al.	
	6,652,537 B2	11/2003 Mercereau et al.	8,187,324 B2	5/2012	Webler et al.	
	6,676,692 B2	1/2004 Rabkin et al.	8,211,171 B2	7/2012	Kim et al.	
	6,695,878 B2	2/2004 McGuckin et al.	8,226,707 B2	7/2012	White	
	6,702,826 B2	3/2004 Liddicoat et al.	8,277,502 B2	10/2012	Miller et al.	
	6,726,716 B2	4/2004 Marquez	8,287,555 B2	10/2012	Starksen et al.	
	6,730,121 B2	5/2004 Ortiz et al.	8,287,591 B2	10/2012	Keidar et al.	
	6,776,791 B1	8/2004 Stallings et al.	8,333,777 B2	12/2012	Schaller et al.	
	6,786,925 B1	9/2004 Schoon et al.	8,349,002 B2	1/2013	Haifa et al.	
	6,790,231 B2	9/2004 Liddicoat et al.	8,357,195 B2	1/2013	Kuehn	
	6,805,710 B2	10/2004 Bolling et al.	8,366,766 B2	2/2013	Berrekouw	
	6,824,562 B2	11/2004 Mathis et al.	8,382,653 B2	2/2013	Dubi et al.	
	6,875,231 B2	4/2005 Anduiza et al.	8,430,926 B2	4/2013	Kirson	
	6,913,608 B2	7/2005 Liddicoat et al.	8,449,604 B2	5/2013	Moaddeb et al.	
	6,942,641 B2	9/2005 Seddon	8,454,683 B2	6/2013	Rafiee et al.	
	6,942,694 B2	9/2005 Liddicoat et al.	8,480,733 B2	7/2013	Navia et al.	
	6,951,571 B1	10/2005 Srivastava	8,512,403 B2	8/2013	Navia et al.	
	6,964,684 B2	11/2005 Ortiz et al.	8,551,161 B2	10/2013	Dolan	
	6,974,476 B2	12/2005 McGuckin et al.	8,551,162 B2	10/2013	Fogarty et al.	
	6,986,775 B2	1/2006 Morales et al.	8,560,009 B2	10/2013	Etamad	
	7,063,722 B2	1/2006 Marquez	8,579,964 B2	11/2013	Lane et al.	
	7,007,698 B2	3/2006 Thornton	8,603,159 B2	12/2013	Seguin et al.	
	7,041,120 B2	5/2006 Li et al.	8,608,797 B2	12/2013	Gross et al.	
	7,081,131 B2	7/2006 Thornton	8,668,713 B2	3/2014	Horan et al.	
	7,087,064 B1	8/2006 Hyde	8,673,001 B2	3/2014	Cartledge et al.	
	7,112,219 B2	9/2006 Vidlund et al.	8,685,080 B2	4/2014	White	
	7,160,322 B2	1/2007 Gabbay	8,690,858 B2	4/2014	Machold et al.	
	7,166,127 B2	1/2007 Spence et al.	8,690,939 B2	4/2014	Miller et al.	
	7,192,442 B2	3/2007 Solam et al.	8,715,342 B2	5/2014	Zipory et al.	
	7,247,134 B2	7/2007 Vidlund et al.	8,721,681 B2	5/2014	Leung et al.	
	7,297,150 B2	11/2007 Cartledge et al.	8,721,718 B2	5/2014	Kassab	
	7,323,004 B2	1/2008 Parihar	8,758,372 B2	6/2014	Cartledge et al.	

(56)

## References Cited

## U.S. PATENT DOCUMENTS

8,778,021 B2	7/2014	Cartledge	2003/0093148 A1	5/2003	Bolling
8,784,482 B2	7/2014	Randert et al.	2003/0158570 A1	8/2003	Ferrazzi
8,808,371 B2	8/2014	Cartledge	2003/0199974 A1	10/2003	Lee et al.
8,858,622 B2	10/2014	Machold et al.	2003/0199975 A1	10/2003	Gabbay
8,864,823 B2	10/2014	Cartledge et al.	2003/0199987 A1	10/2003	Berg et al.
8,882,830 B2	11/2014	Cartledge et al.	2003/0212453 A1	11/2003	Mathis et al.
8,906,046 B2	12/2014	Anderson	2003/0225420 A1	12/2003	Wardle
8,926,696 B2	1/2015	Cabiri et al.	2003/0233142 A1	12/2003	Morales et al.
8,940,042 B2	1/2015	Miller et al.	2004/0010275 A1	1/2004	Jacobs et al.
8,945,210 B2	2/2015	Cartledge et al.	2004/0049266 A1	3/2004	Anduiza et al.
8,956,407 B2	2/2015	Macoviak et al.	2004/0067544 A1	4/2004	Vogel et al.
8,979,923 B2	3/2015	Spence et al.	2004/0092965 A1	5/2004	Parihar
8,979,925 B2	3/2015	Chang et al.	2004/0122516 A1	6/2004	Fogarty et al.
8,992,604 B2	3/2015	Gross et al.	2004/0127982 A1	7/2004	Machold et al.
8,998,979 B2	4/2015	Seguin	2004/0133274 A1	7/2004	Webler et al.
9,005,272 B2	4/2015	White	2004/0148019 A1	7/2004	Vidlund et al.
9,011,520 B2	4/2015	Miller et al.	2004/0148020 A1	7/2004	Vidlund et al.
9,023,065 B2	5/2015	Bolduc et al.	2004/0148021 A1	7/2004	Cartledge et al.
9,040,092 B2	5/2015	Edelman et al.	2004/0167620 A1	8/2004	Ortiz et al.
9,044,221 B2	6/2015	Zentgraf et al.	2004/0172063 A1	9/2004	Li et al.
9,084,677 B2	7/2015	Cartledge et al.	2004/0186565 A1	9/2004	Schreck
9,095,277 B2 *	8/2015	House ..... A61B 8/0883	2004/0193191 A1	9/2004	Starksen et al.
9,101,338 B2	8/2015	Hindrichs et al.	2004/0193261 A1	9/2004	Berrekouw
9,107,749 B2	8/2015	Bobo et al.	2004/0236419 A1	11/2004	Milo
9,107,750 B2	8/2015	Cartledge et al.	2004/0243104 A1	12/2004	Seddon
9,119,718 B2	9/2015	Keranen	2004/0243227 A1	12/2004	Starksen et al.
9,138,315 B2	9/2015	Straubinger et al.	2004/0243230 A1	12/2004	Navia et al.
9,180,005 B1	11/2015	Lashinski et al.	2004/0249400 A1	12/2004	Vargas et al.
9,192,471 B2	11/2015	Bolling	2004/0249453 A1	12/2004	Cartledge et al.
9,192,472 B2	11/2015	Gross et al.	2004/0260394 A1	12/2004	Douk et al.
9,198,755 B2	12/2015	Shaolain et al.	2005/0004665 A1	1/2005	Aklog
9,204,956 B2	12/2015	Chanduszko et al.	2005/0004668 A1	1/2005	Aklog et al.
9,204,964 B2	12/2015	Dahlgren et al.	2005/0038508 A1	2/2005	Gabbay
9,265,608 B2	2/2016	Miller et al.	2005/0049692 A1	3/2005	Numamoto
9,301,756 B2	4/2016	Wardle	2005/0075713 A1	4/2005	Biancucci et al.
9,301,860 B2	4/2016	White	2005/0080454 A1	4/2005	Drews et al.
9,314,336 B2	4/2016	Furnish et al.	2005/0119734 A1	6/2005	Spence et al.
9,326,859 B2	5/2016	Cartledge et al.	2005/0131533 A1	6/2005	Alfieri et al.
9,339,379 B2	5/2016	Quadri et al.	2005/0137701 A1	6/2005	Salahieh et al.
9,351,830 B2	5/2016	Gross et al.	2005/0177180 A1	8/2005	Kaganov et al.
RE46,126 E	8/2016	Kirson	2005/0182290 A1	8/2005	Lau et al.
RE46,127 E	8/2016	Kirson	2005/0182486 A1	8/2005	Gabbay
9,421,099 B2	8/2016	Dolan	2005/0192629 A1	9/2005	Saadat et al.
9,427,215 B2	8/2016	Cartledge et al.	2005/0197696 A1	9/2005	Gomez
9,439,763 B2	9/2016	Geist et al.	2005/0234508 A1	10/2005	Cummins et al.
9,474,606 B2	10/2016	Zipory et al.	2005/0250986 A1	11/2005	Rothe et al.
9,492,276 B2	11/2016	Lee et al.	2005/0267560 A1	12/2005	Bates
9,504,572 B2	11/2016	Mauch et al.	2005/0267572 A1	12/2005	Schoon et al.
9,566,178 B2	2/2017	Cartledge et al.	2005/0288776 A1	12/2005	Shaoulian et al.
9,585,747 B2	3/2017	Quadri et al.	2005/0288783 A1	12/2005	Shaoulian et al.
9,592,122 B2	3/2017	Zipory et al.	2006/0015178 A1	1/2006	Moaldeb et al.
9,597,184 B2	3/2017	Machold et al.	2006/0020332 A1	1/2006	Lashinsky et al.
9,610,156 B2	4/2017	Lashinski	2006/0025854 A1	2/2006	Lashinski et al.
9,616,197 B2 *	4/2017	Serina ..... A61M 25/0043	2006/0025855 A1	2/2006	Lashinski et al.
9,713,530 B2	7/2017	Cabiri et al.	2006/0025858 A1	2/2006	Alameddine
9,730,790 B2	8/2017	Quadri et al.	2006/0100699 A1	5/2006	Vidlund et al.
9,744,038 B2	8/2017	Dahlgren et al.	2006/0106305 A1	5/2006	Lau
9,775,709 B2	10/2017	Miller et al.	2006/0106456 A9	5/2006	Machold et al.
9,788,941 B2	10/2017	Hacohen	2006/0129235 A1	6/2006	Seguin et al.
9,801,714 B2	10/2017	White	2006/0149349 A1	7/2006	Garbe
9,827,093 B2	11/2017	Cartledge et al.	2006/0149368 A1	7/2006	Spence
9,848,983 B2	12/2017	Lashinski et al.	2006/0178733 A1	8/2006	Pinchuk et al.
9,861,475 B2	1/2018	Machold et al.	2006/0184240 A1	8/2006	Jimenez et al.
9,872,769 B2 *	1/2018	Gross ..... A61F 2/2445	2006/0184241 A1	8/2006	Marquez
9,883,943 B2	2/2018	Gross et al.	2006/0195012 A1	8/2006	Mortier et al.
2001/0044637 A1	11/2001	Jacobs et al.	2006/0206203 A1	9/2006	Yang et al.
2002/0002401 A1	1/2002	McGuckin et al.	2006/0229708 A1	10/2006	Powell et al.
2002/0042621 A1	4/2002	Liddicoat et al.	2006/0241746 A1	10/2006	Shaoulian et al.
2002/0151961 A1	10/2002	Lashinski et al.	2006/0241747 A1	10/2006	Shaoulian et al.
2002/0161377 A1	10/2002	Rabkin	2006/0241748 A1	10/2006	Lee et al.
2002/0173841 A1	11/2002	Ortiz et al.	2006/0282161 A1	12/2006	Huynh et al.
2002/0183837 A1	12/2002	Streeter et al.	2006/0282162 A1	12/2006	Nguyen et al.
2003/0040793 A1	2/2003	Marquez	2007/0005129 A1	1/2007	Damm et al.
2003/0050693 A1	3/2003	Quijano et al.	2007/0016287 A1	1/2007	Cartledge et al.
2003/0083742 A1	5/2003	Spence et al.	2007/0016288 A1	1/2007	Gurskis et al.
			2007/0027533 A1	2/2007	Douk
			2007/0027536 A1	2/2007	Mihaljevic et al.
			2007/0049942 A1	3/2007	Hindrichs et al.
			2007/0050019 A1	3/2007	Hyde



(56)

## References Cited

## FOREIGN PATENT DOCUMENTS

WO	WO 01/89440	11/2001
WO	WO 02/034121	5/2002
WO	WO 02/094132	11/2002
WO	WO 03/017874	3/2003
WO	WO 03/053289	7/2003
WO	WO 03/080150	10/2003
WO	WO 03/105670	12/2003
WO	WO 03/105730	12/2003
WO	WO 04/014282	2/2004
WO	WO 04/019816	3/2004
WO	WO 04/019826	3/2004
WO	WO 04/030569	4/2004
WO	WO 04/031717	4/2004
WO	WO 04/032717	4/2004
WO	WO 04/082538	9/2004
WO	WO 04/103223	12/2004
WO	WO 04/112657	12/2004
WO	WO 05/002424	1/2005
WO	WO 05/007037	1/2005
WO	WO 05/046488	5/2005
WO	WO 05/087139	9/2005
WO	WO 06/011275	2/2006
WO	WO 06/052687	5/2006
WO	WO 06/086135	8/2006
WO	WO 06/086434	8/2006
WO	WO 06/105084	10/2006
WO	WO 06/116129	11/2006
WO	WO 06/116357	11/2006
WO	WO 07/021834	2/2007
WO	WO 07/103562	9/2007
WO	WO 07/136783	11/2007
WO	WO 08/15257	2/2008
WO	WO 08/068756	6/2008
WO	WO 08/088716	7/2008
WO	WO 09/120764	10/2009
WO	WO 09/126629	10/2009
WO	WO 09/140268	11/2009
WO	WO 10/011699	1/2010
WO	WO 10/048151	4/2010
WO	WO 12/027116	3/2012
WO	WO 12/167095	12/2012
WO	WO 13/088327	6/2013
WO	WO 15/77599	5/2015

## OTHER PUBLICATIONS

International Search Report dated Jul. 1, 2008 for Application No. PCT/US2008/050224.

International Search Report dated Jul. 13, 2010 for PCT/US2010/027943.

International Search Report dated Sep. 22, 2011 for PCT/US2011/039022.

International Search Report dated Dec. 7, 2011 for PCT/US2011/047345.

International Search Report dated Dec. 11, 2013 for PCT/US2013/059751.

International Search Report dated Jul. 21, 2014 for PCT/US2014/026333.

International Search Report dated May 5, 2016 in PCT/US2016/017866.

International Search Report dated Apr. 19, 2017 in PCT/US16/062107.

International Search Report and Written Opinion dated May 26, 2017 for PCT/US2017/016284.

B. Braun Medical Inc., "Pulmonary Embolism: IVC Filters." Retrieved from the Internet: <http://www.bbraunusa.com/pe/pe05a.html>, 2004, 2 pages.

Bonow et al., "ACC/AHA 2006 Guidelines for the Management of Patients with Valvular Heart Disease," *J. American College of Cardiology*, 48(3):e1-148 (2006).

Boston Scientific, "Device Details." Retrieved from the Internet: [http://bostonscientific.com/rned\\_specialty/deviceDetail.jsp](http://bostonscientific.com/rned_specialty/deviceDetail.jsp) [retrieved on Aug. 31, 2006], 1 page.

Braunberger et al., "Very Long-Term Results (More Than 20 years) of Valve Repair with Carpentier's Techniques in Nonrheumatic Mitral Valve Insufficiency," *Circulation*, 104:18-111 (2001).

Braunwald et al., "Conservative Management of tricuspid Regurgitation in Patients Undergoing Mitral Valve Replacement," *Circulation*, XXXV and XXXVI:163-169 (1967).

Carpentier et al., "Surgical Management of Acquired Tricuspid Valve Disease," *J. Thoracic and Cardiovascular Surgery*, 67(1):53-65 (1974).

Center for Devices and Radiological Health, U.S. Dept. of Health and Human Services Food and Drug Administration "Guidance for Annuloplasty Rings 510(k) Submissions; Final Guidance for Industry and FDA Staff," 1-15 (2001).

Cosgrove et al., "Mitral Valvuloplasty," *Curro. Probl. Cardiol.*, 359-405 (1989).

Dreyfus et al., "Secondary Tricuspid Regurgitation or Dilatation: Which Should Be the Criteria for Surgical Repair?," *Ann. Thorac. Surg.*, 79:127-32 (2005).

Google Images, Recurved Hooks. Retrieved from the Internet: [www.implementology.org/pf](http://www.implementology.org/pf) and [personal.cityu.edu.hk](http://personal.cityu.edu.hk) [retrieved on Dec. 14, 2006], 1 page.

Leung et al., "Barbed, Bi-directional Surgical Sutures: In Vivo Strength and Histopathology Evaluations," *Society for Biomaterials 28th Annual Meeting Transactions*, #724 (2003) 1 page.

Magovern et al., "Sutureless Artificial Heart Valves," *Circulation*, 27:784-788 (1963).

McCarthy et al., "Tricuspid Valve Repair: Durability and Risk Factors for Failure," *J. Thoracic and Cardiovascular Surgery*, 127:674-85 (2004).

Nath et al., "Impact of Tricuspid Regurgitation on Long-Term Survival," *J. American College of Cardiology*, 43(3):405-409 (2004).

Navia et al., "Surgical Management of Secondary Tricuspid Valve Regurgitation: Anulus, Commissure, or Leaflet Procedure?," Abstract presented at American Association for Thoracic Surgery Annual Meeting (2009).

Rogers et al., "The Tricuspid Valve: Current Perspective and Evolving Management of Tricuspid Regurgitation," *Circulation*, 119:2718-2725 (2009).

Sagie et al., "Determinants of Functional Tricuspid Regurgitation in Incomplete Tricuspid Valve Closure: Doppler Color Flow Study of 109 Patients," *J. American College of Cardiology*, 24:446-53 (1994).

Savage et al., "Use of Mitral Valve Repair: Analysis of Contemporary United States Experience Reported to the Society of Thoracic Surgeons National Cardiac Database," *Ann. Thorac Surg.*, 75:820-825 (2003).

Shiran et al., "Tricuspid Regurgitation in Mitral Valve Disease," *J. American College of Cardiology*, 53(5):401-408 (2009).

Song et al., "Factors Associated with Development of Late Significant Tricuspid Regurgitation after Successful Left-Sided Valve Surgery," *Heart*, 95:931-936 (2009).

Tang et al., "Tricuspid Valve Repair with an Annuloplasty Ring Results in Improved Long-Term Outcomes," *Circulation*, 114:1577-1581 (2006).

Thompson, "Percutaneous Heart Valve Technology: The Mitral Challenge," *Medtech Insight*, 11(2):38-52 (2009).

Zlotnick et al., "A Perfectly Functioning Magovern-Cromie Sutureless Prosthetic Aortic Valve 42 Years After Implantation," *Circulation*, 117:e1-e2 (2008).

\* cited by examiner

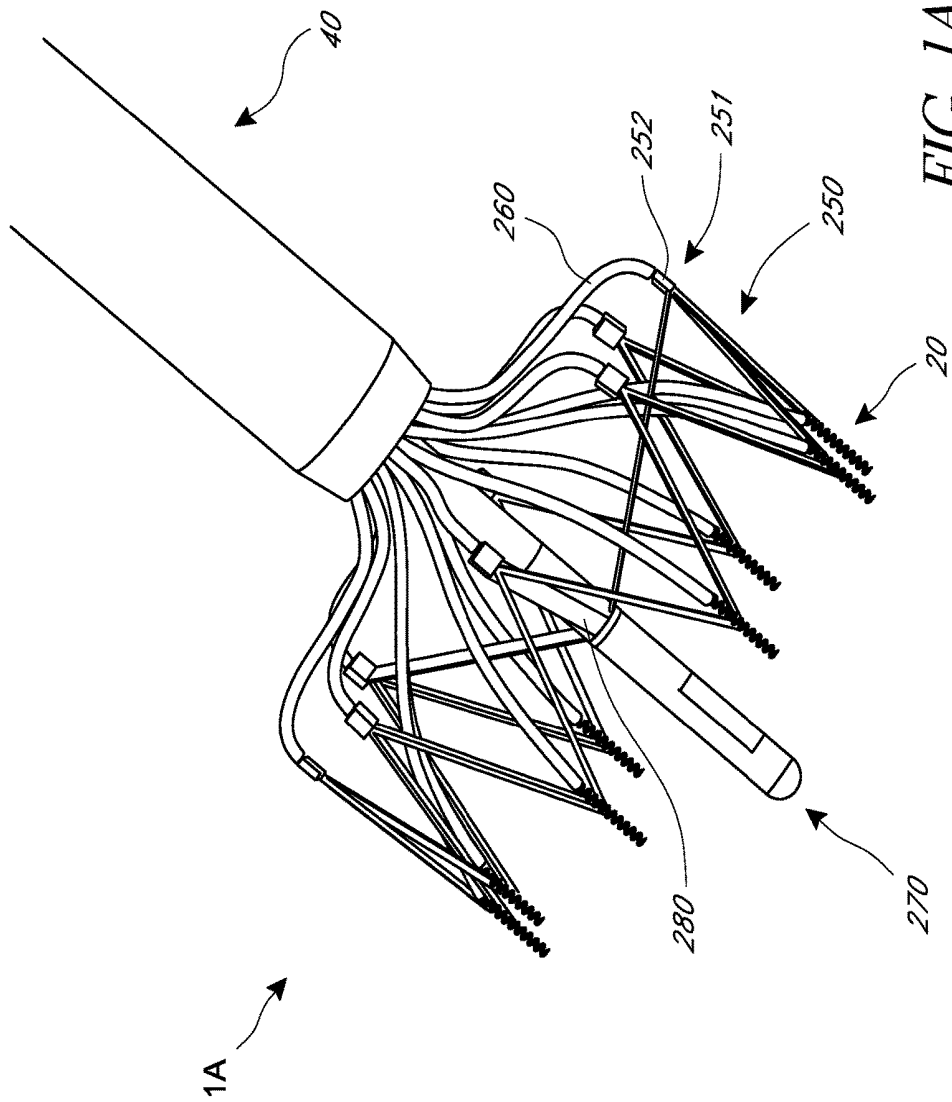

FIG. 1A

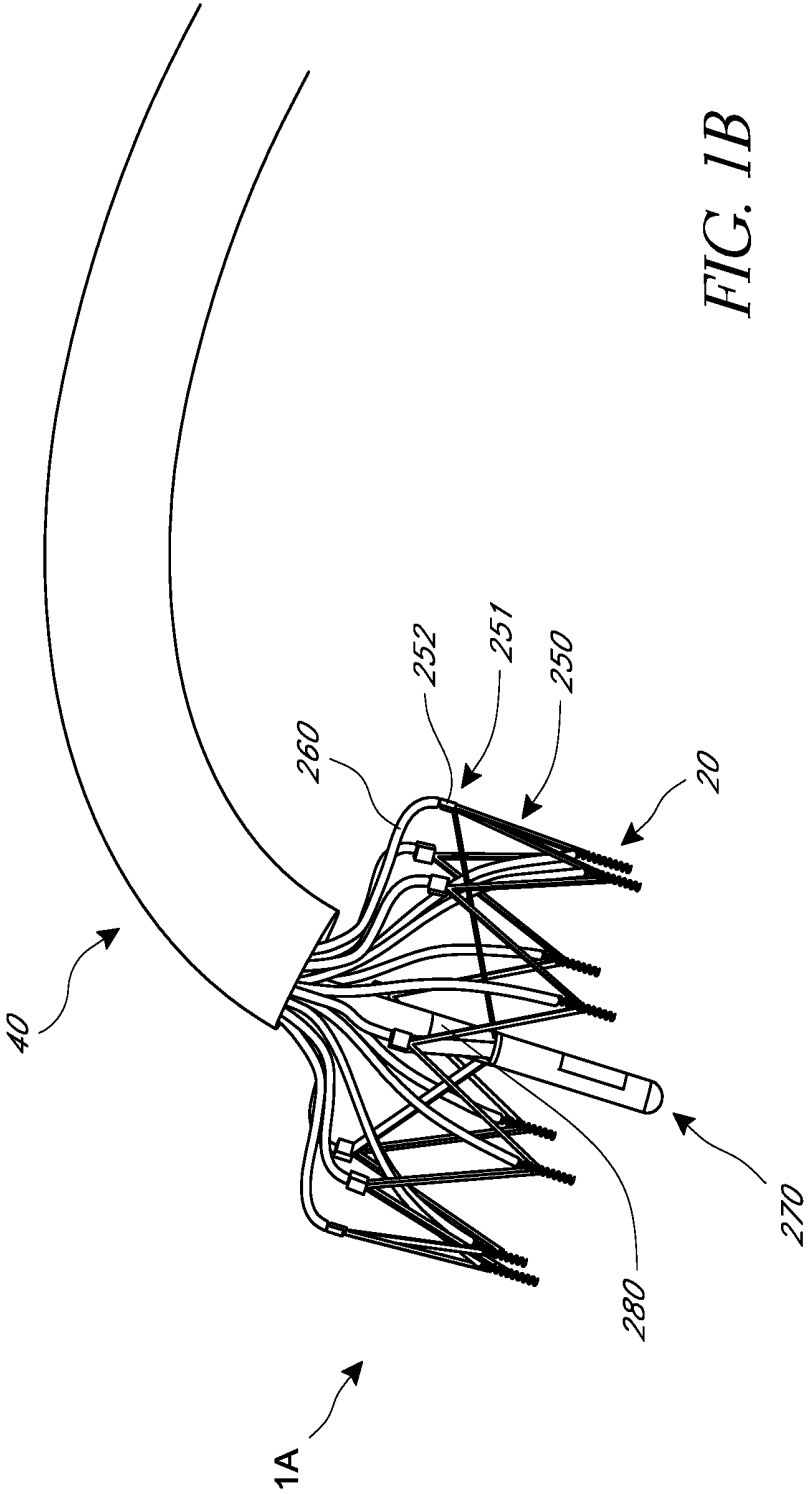

FIG. 1B

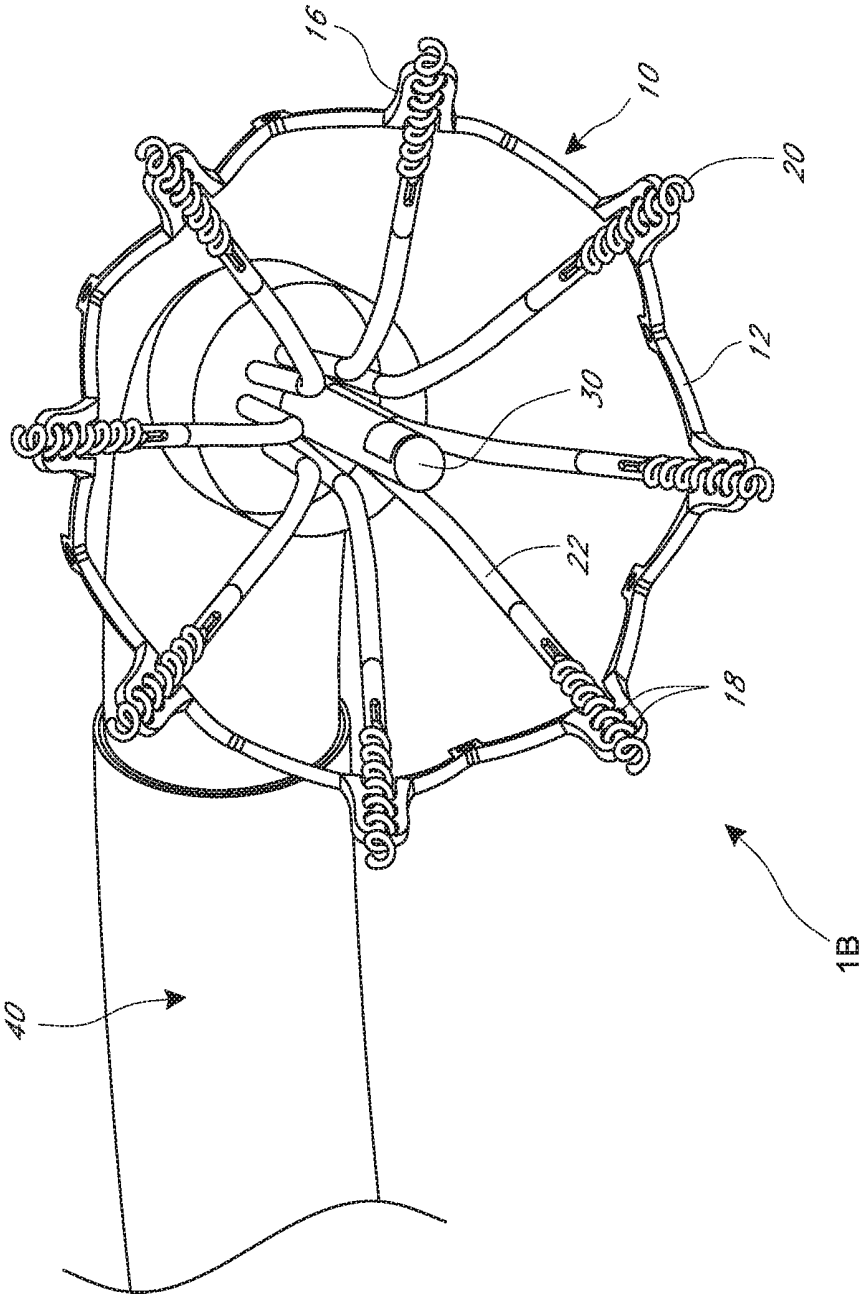

FIG. 1C

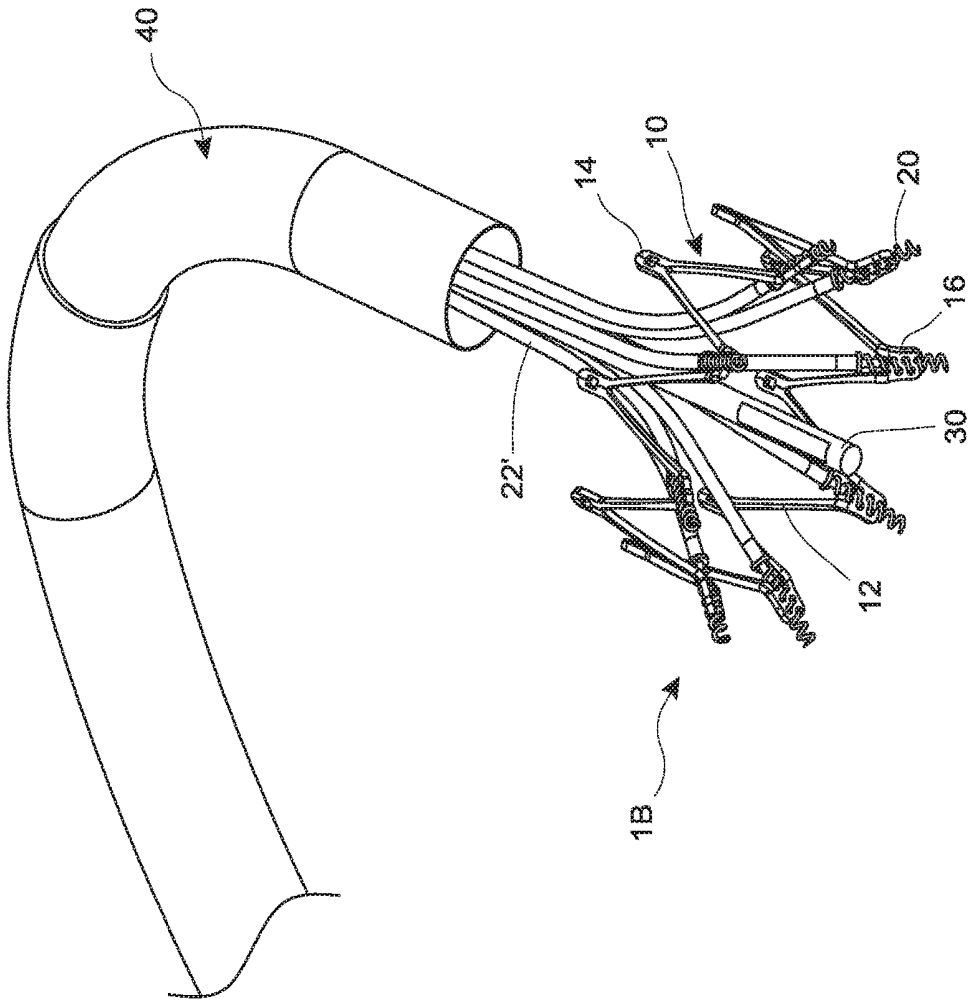

FIG. 1D

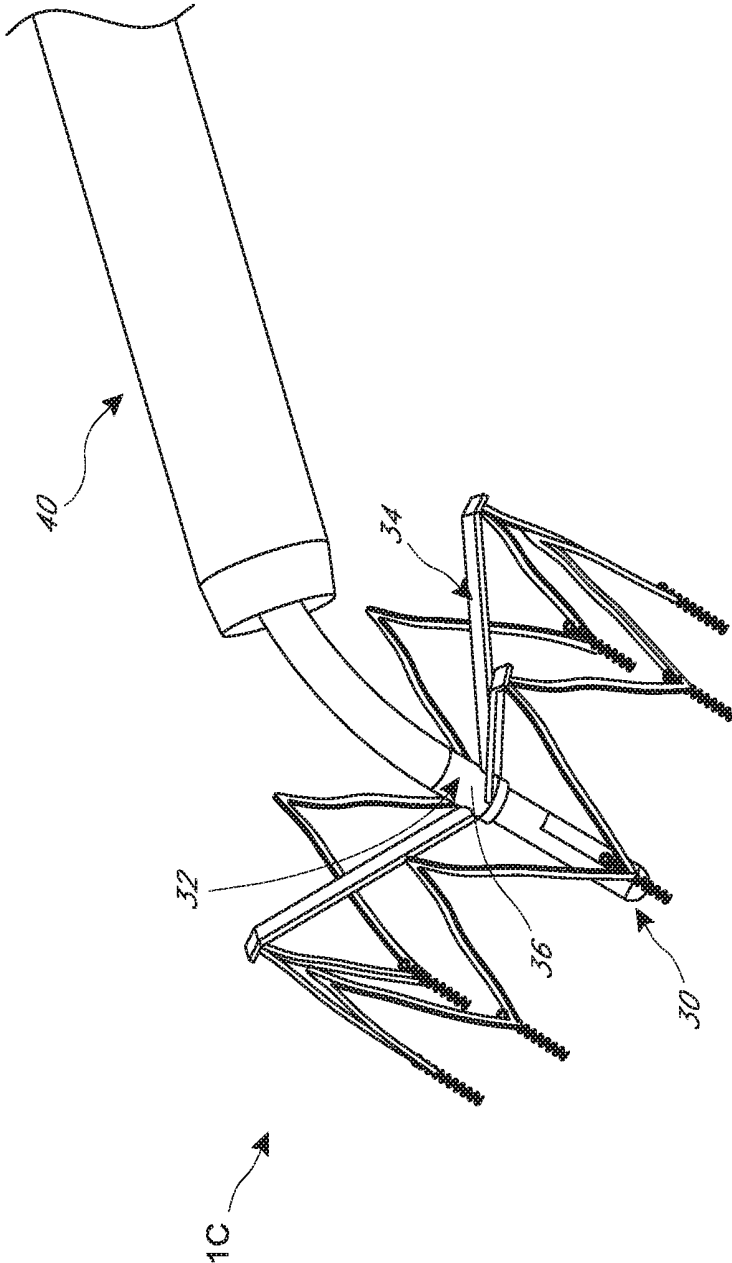

FIG. 1E

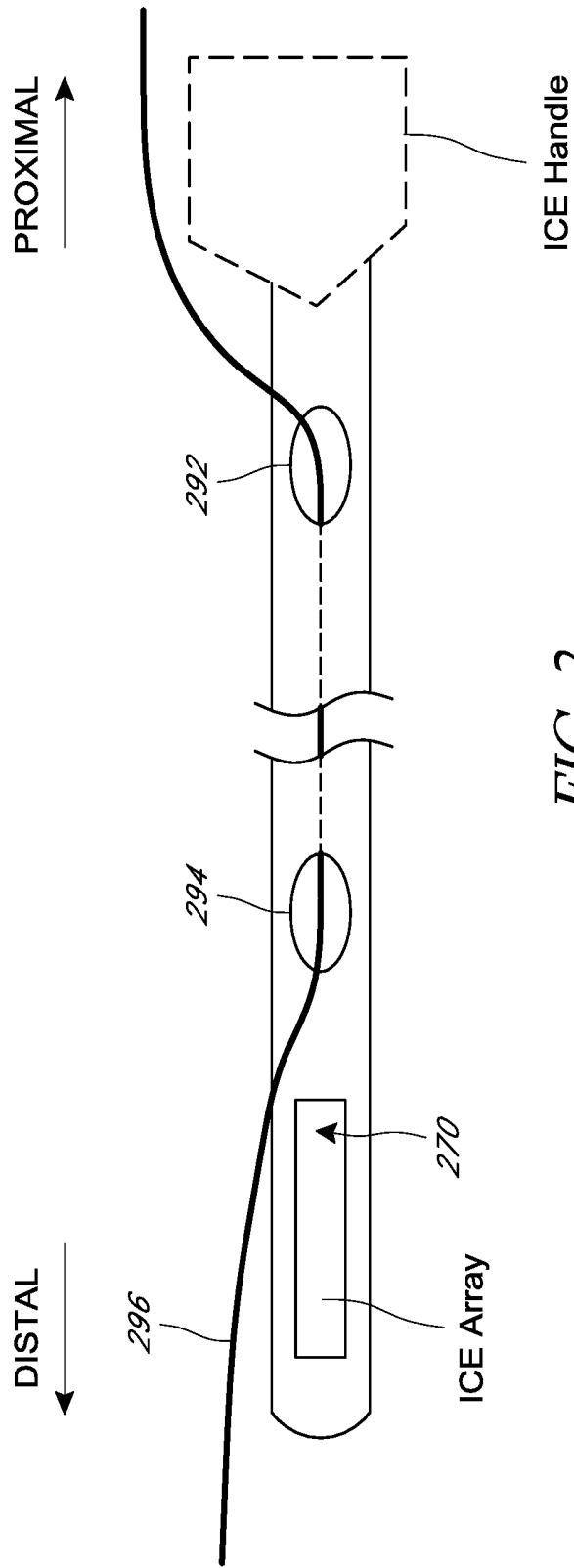
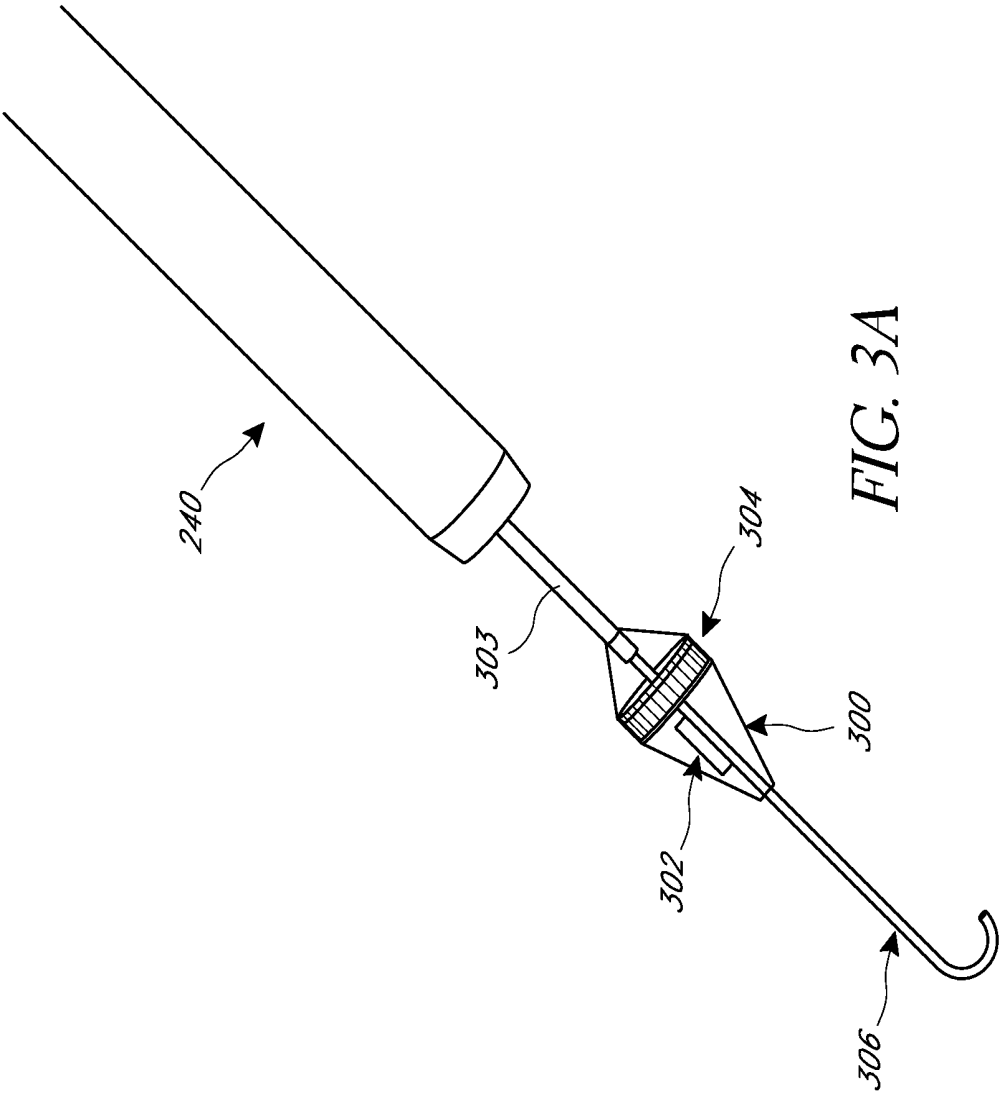

FIG. 2



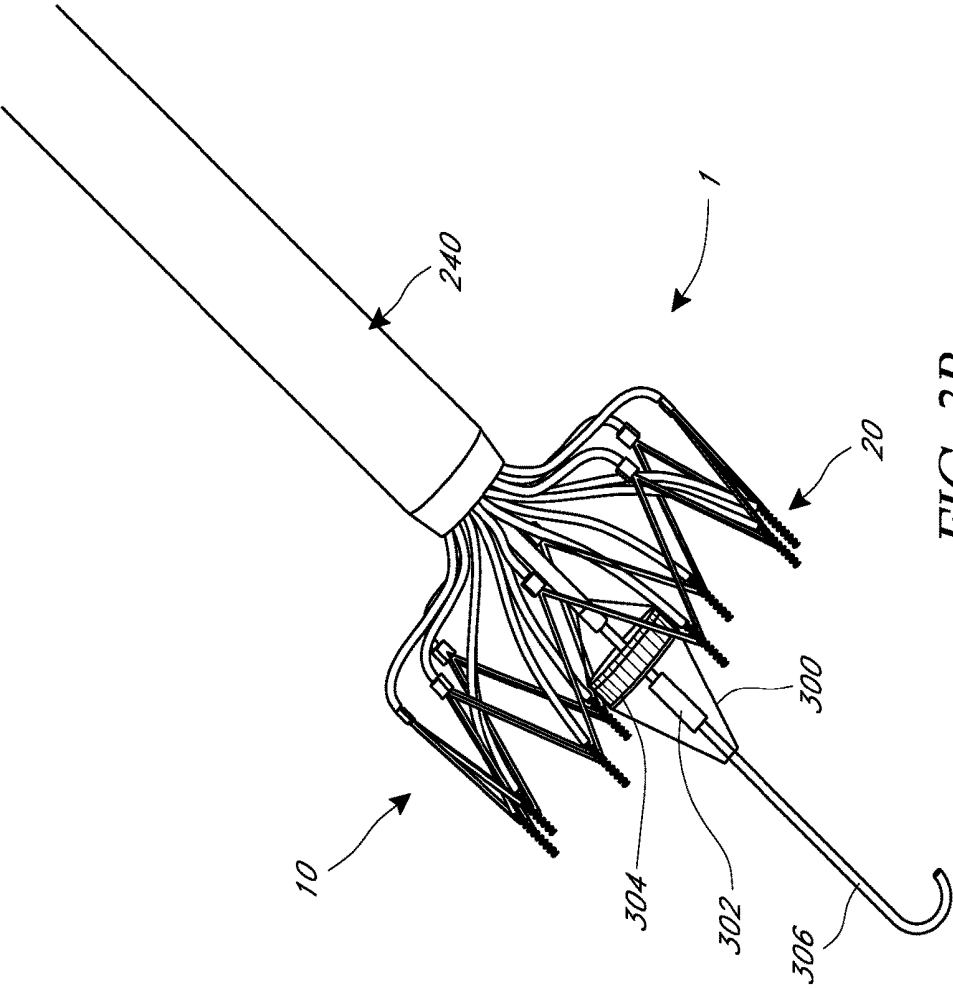

FIG. 3B

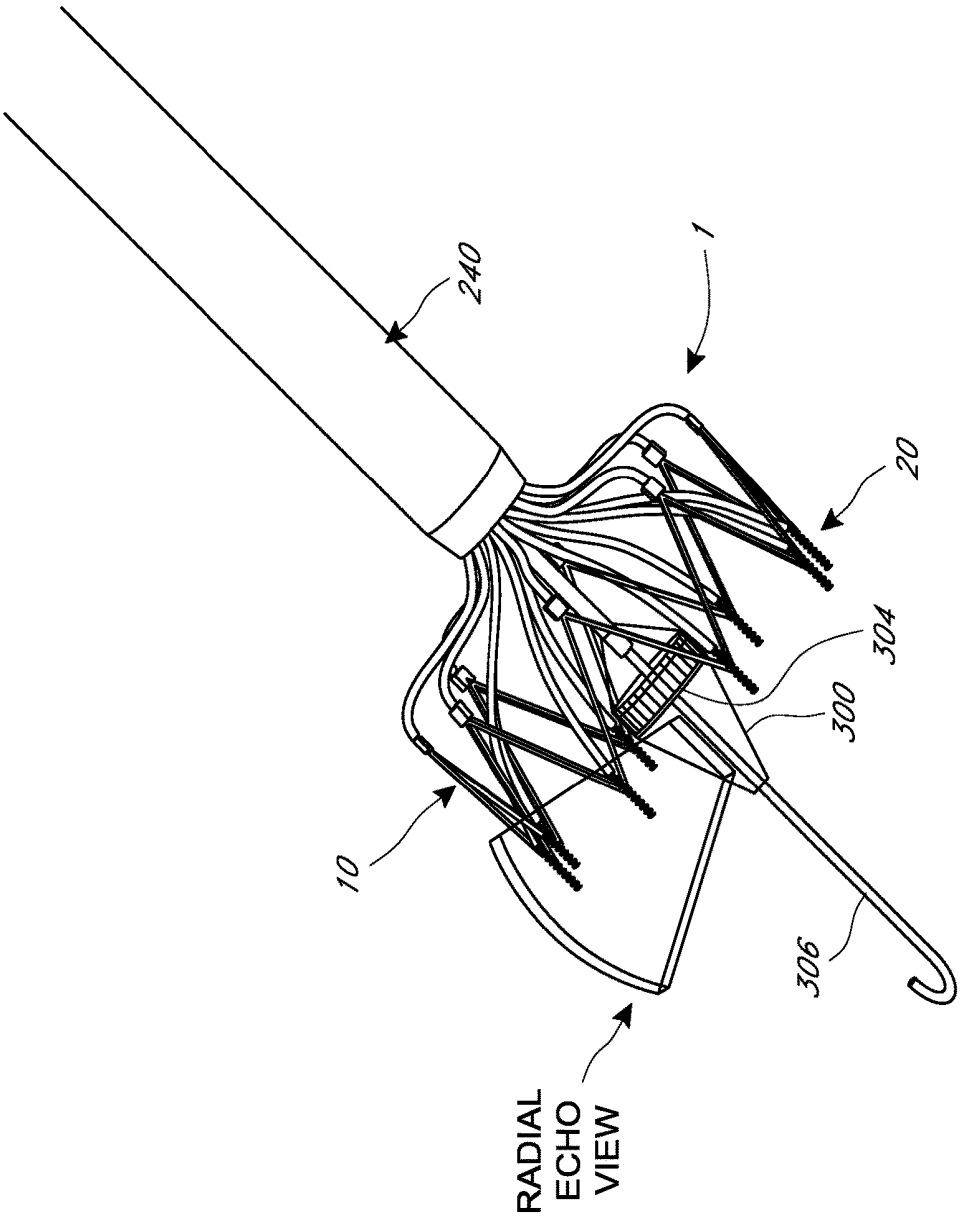

FIG. 3C

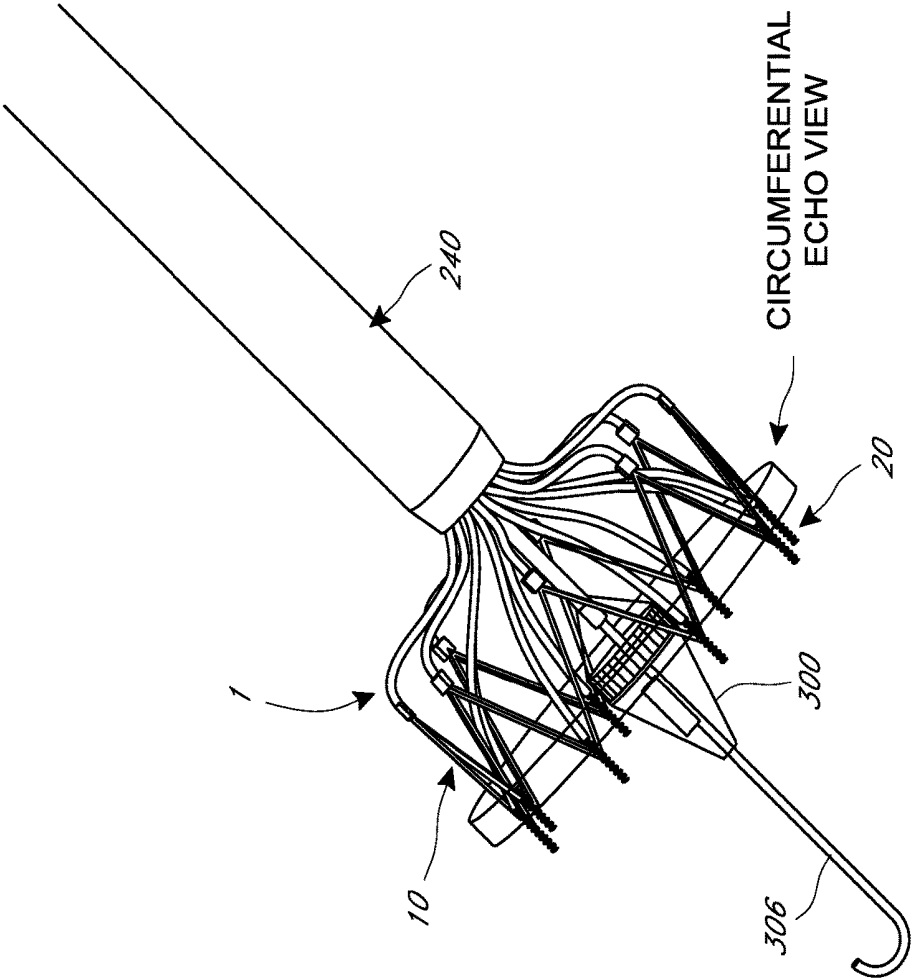

FIG. 3D

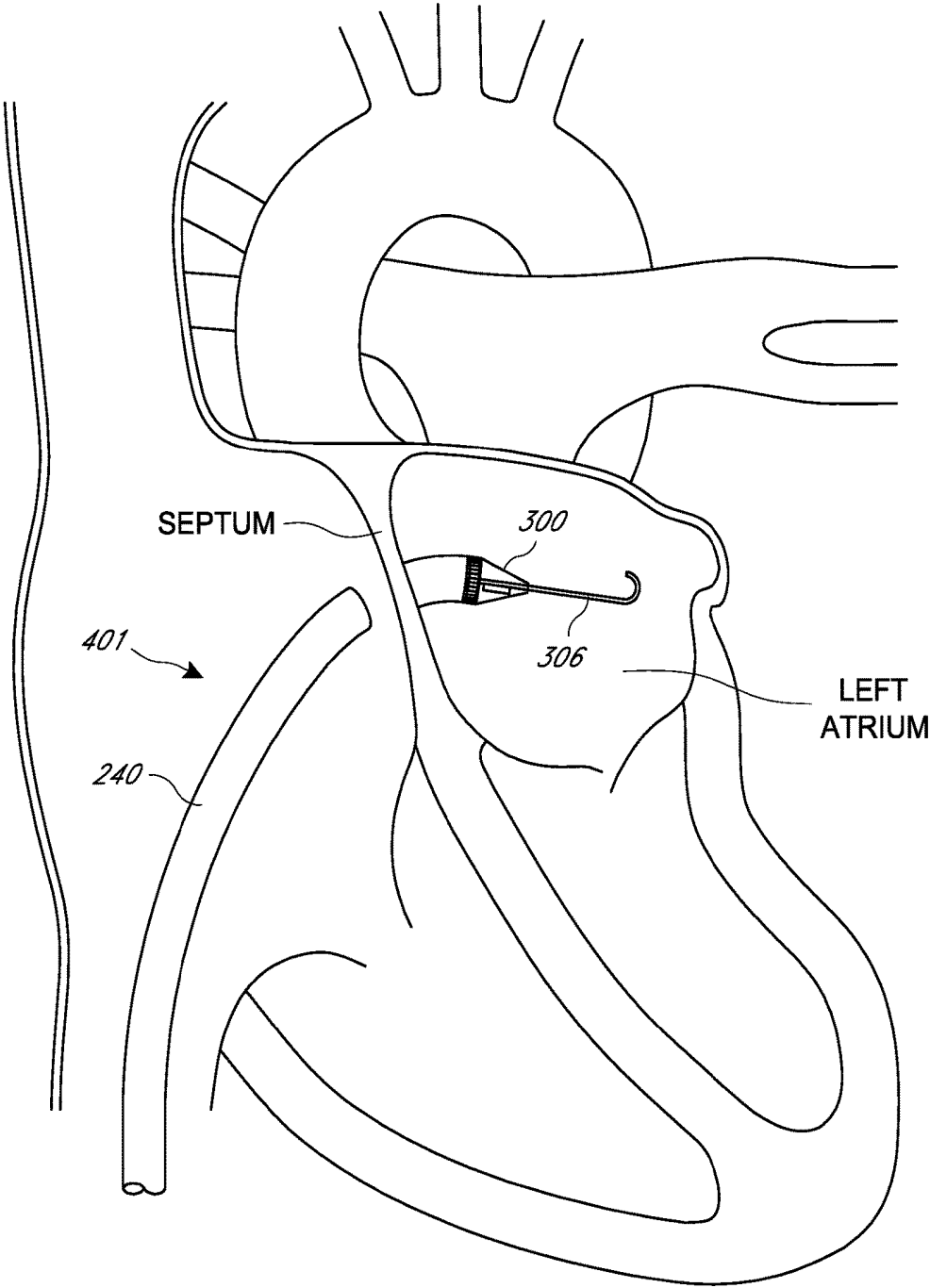

FIG. 4A

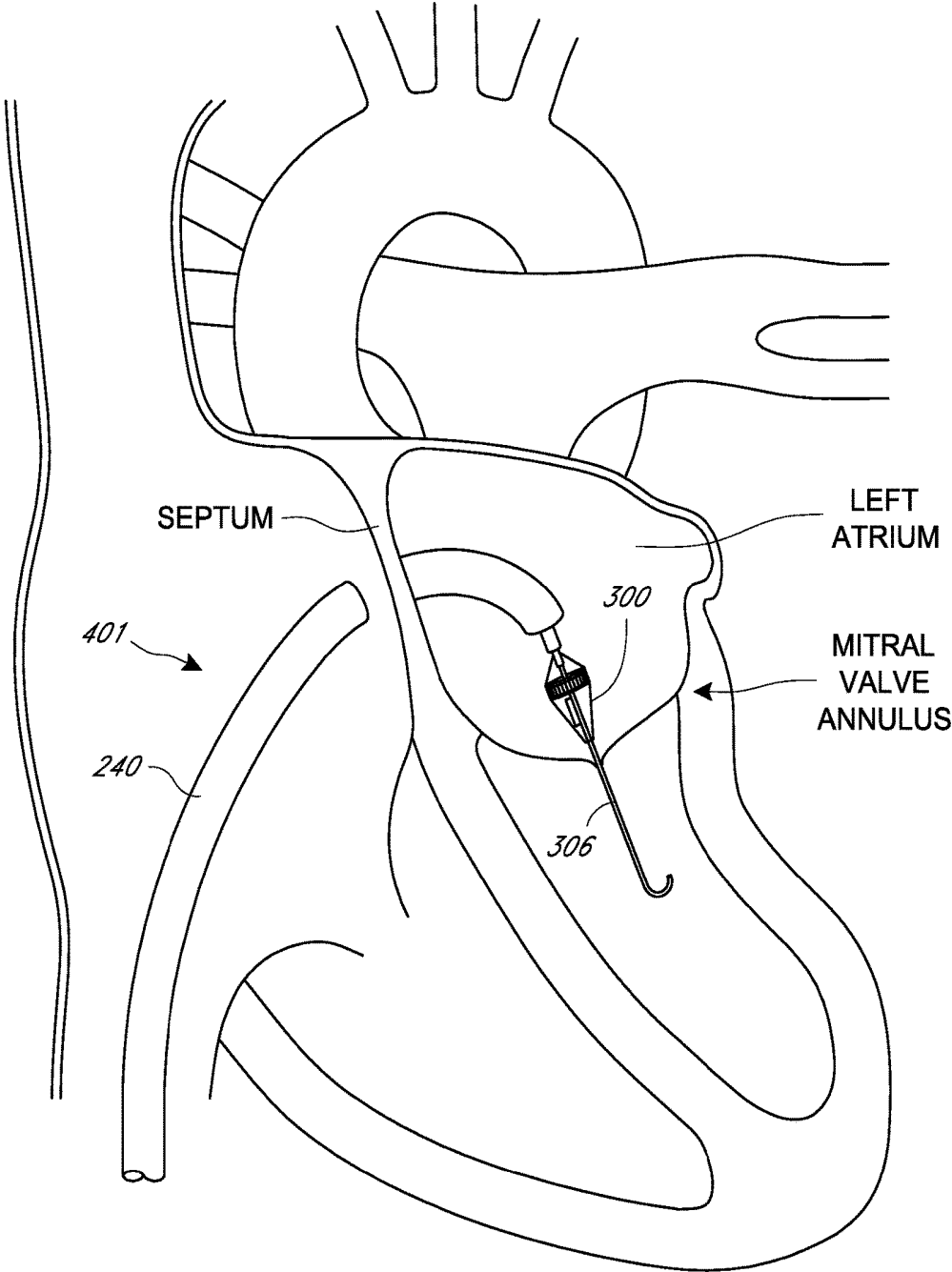

FIG. 4B

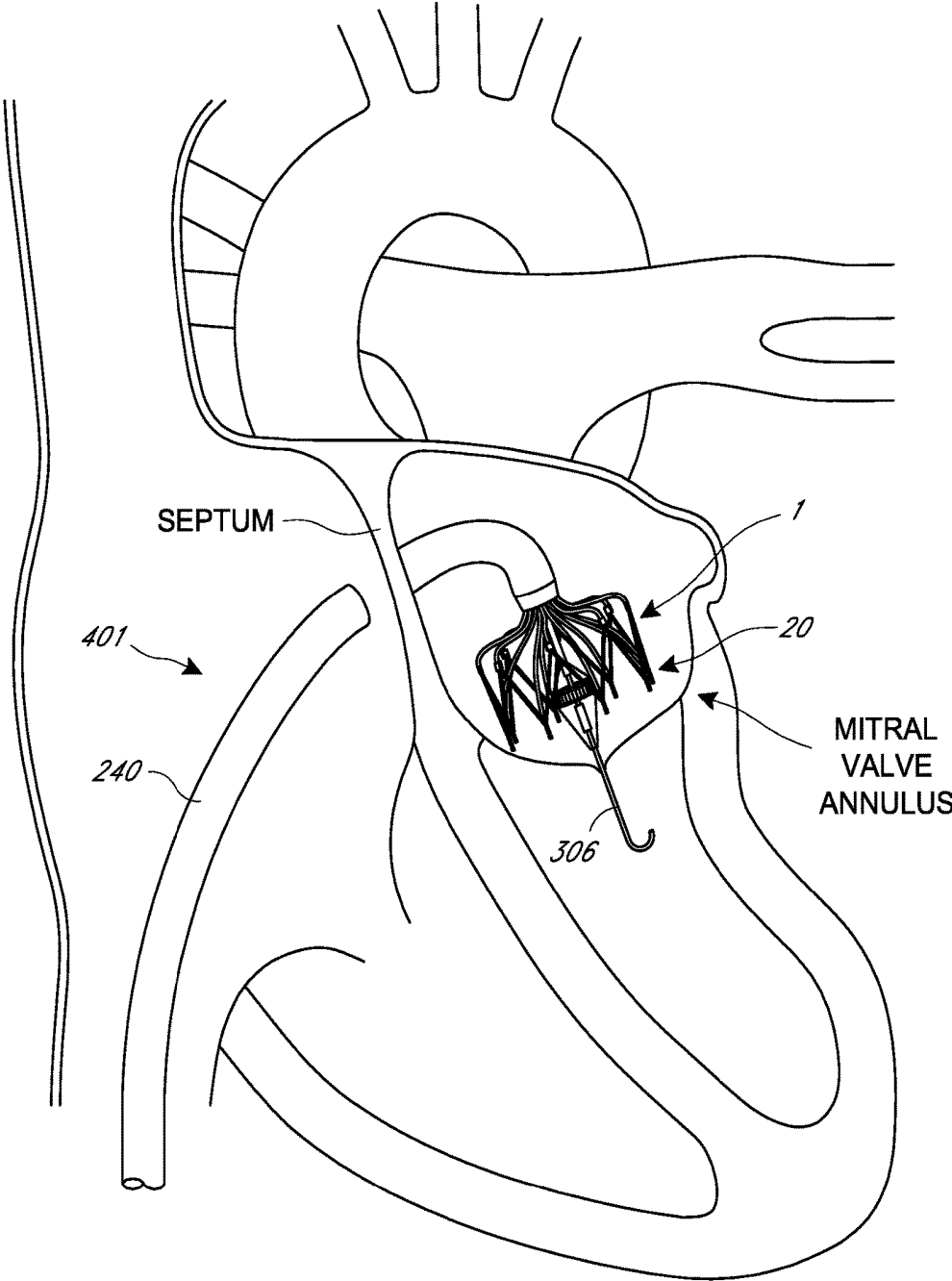

FIG. 4C

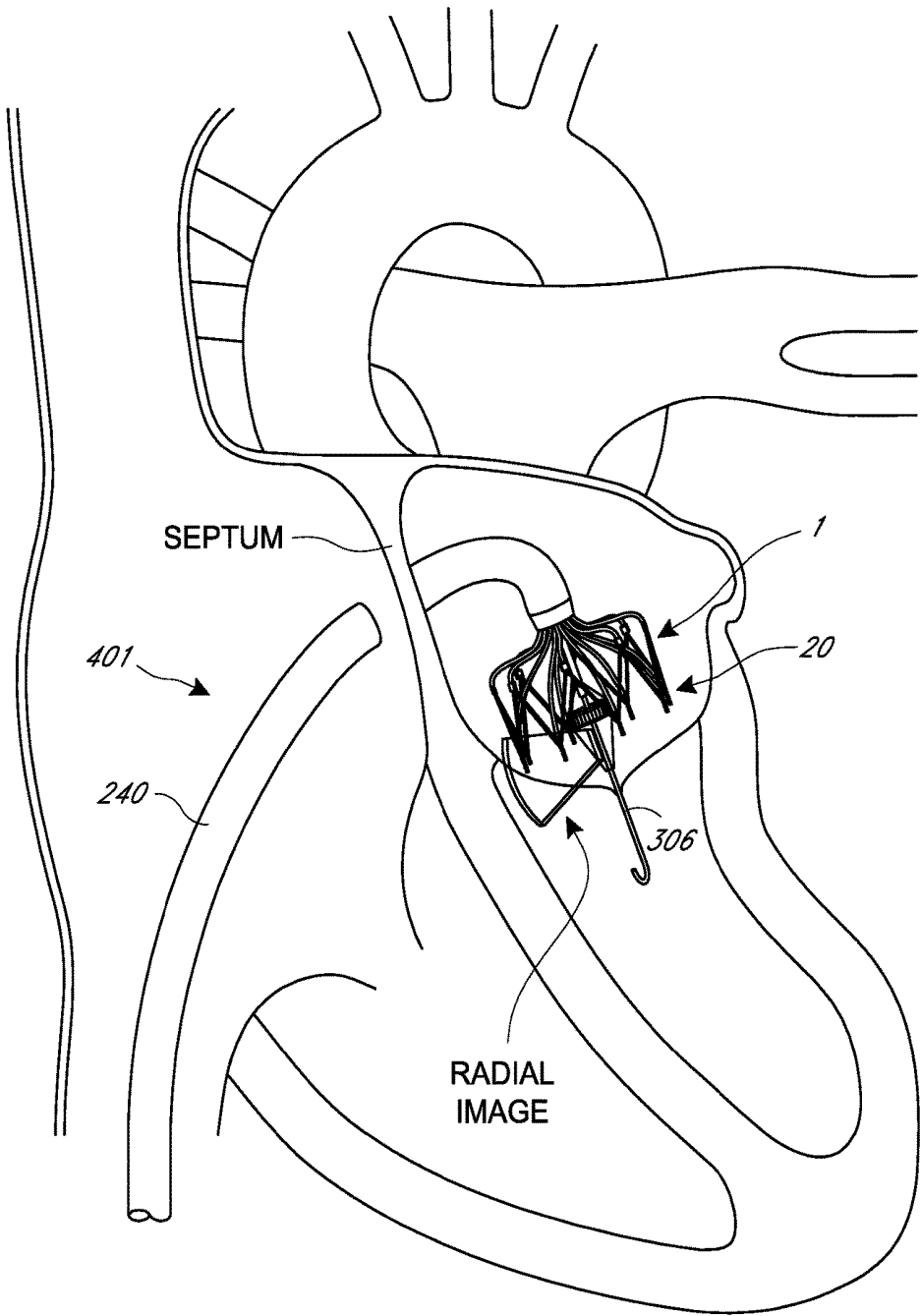

FIG. 4D

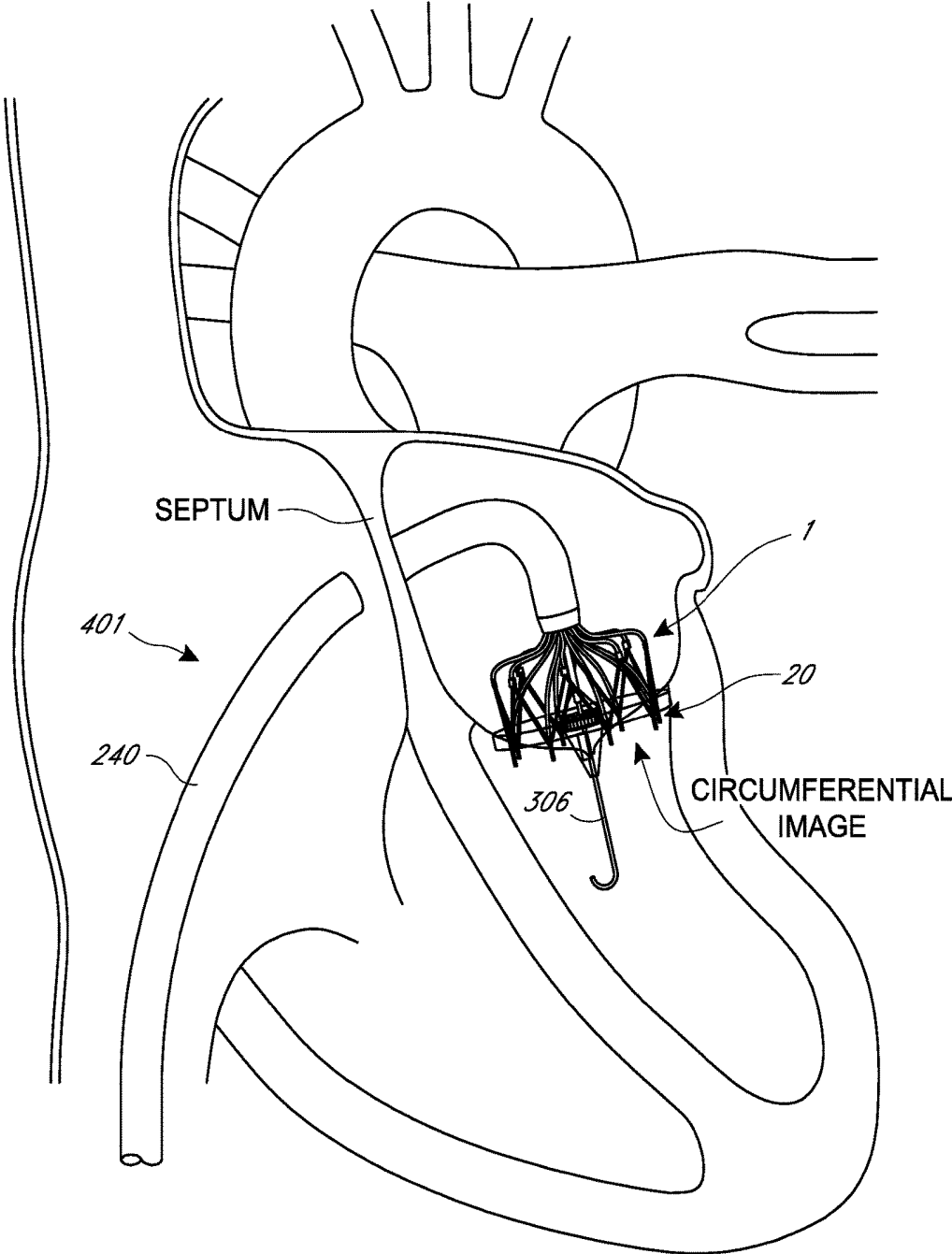

FIG. 4E

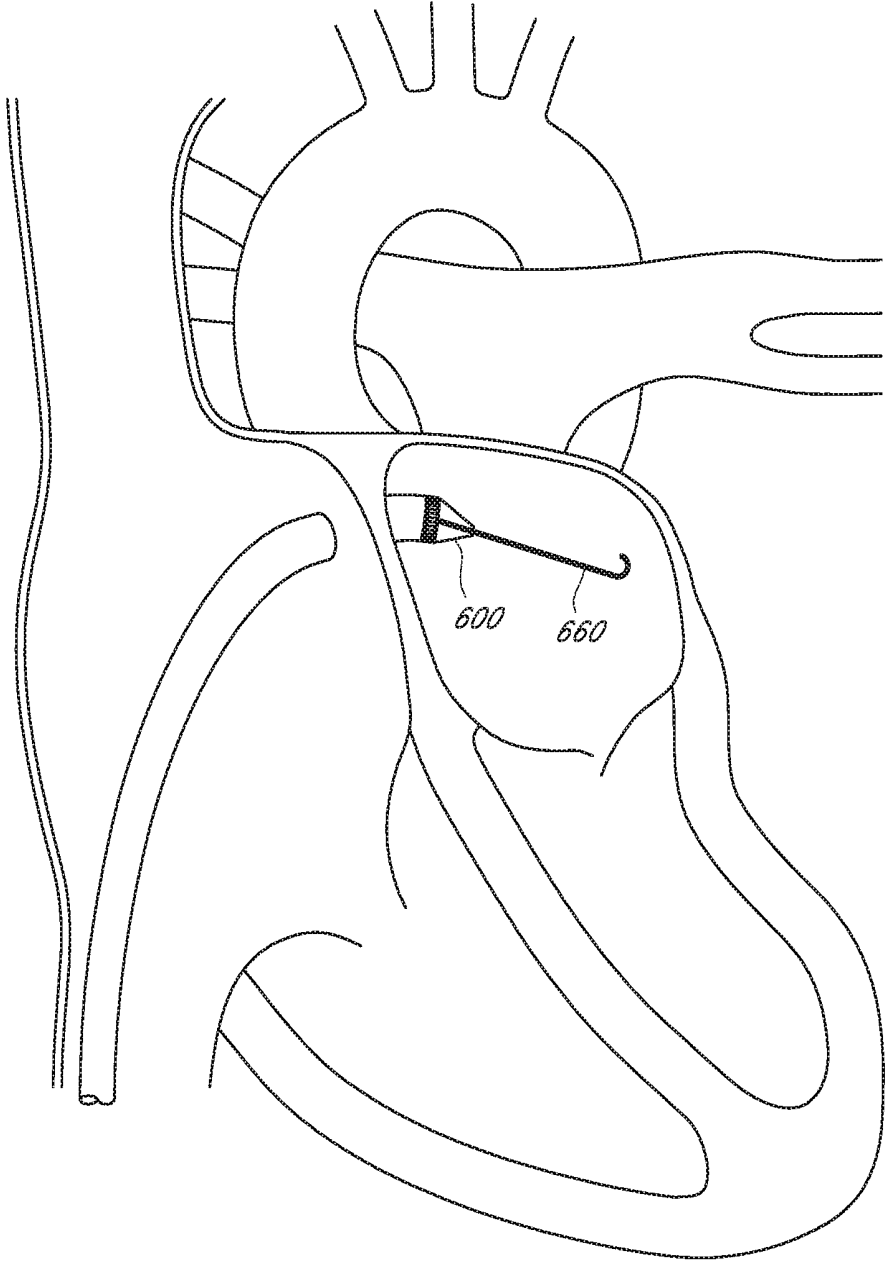

FIG. 5A

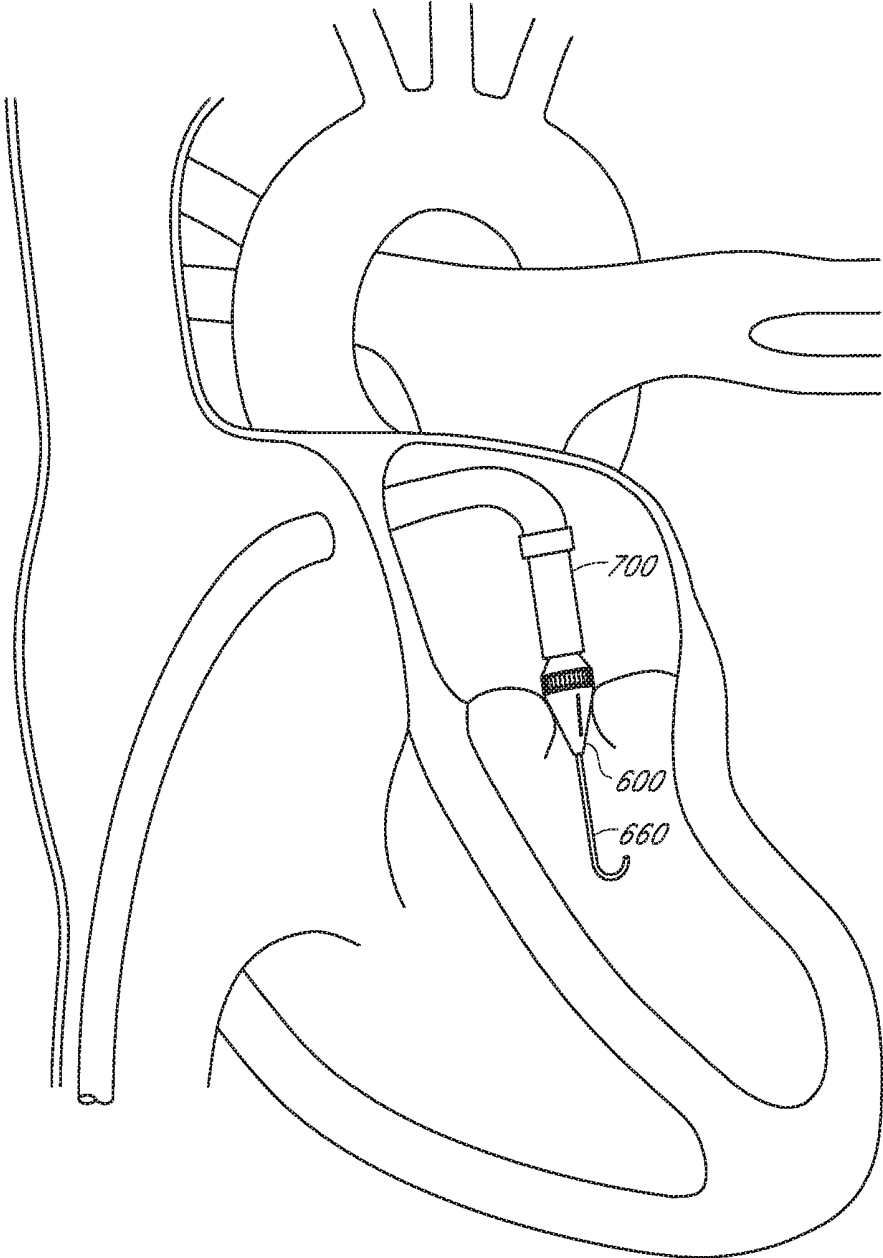

FIG. 5B

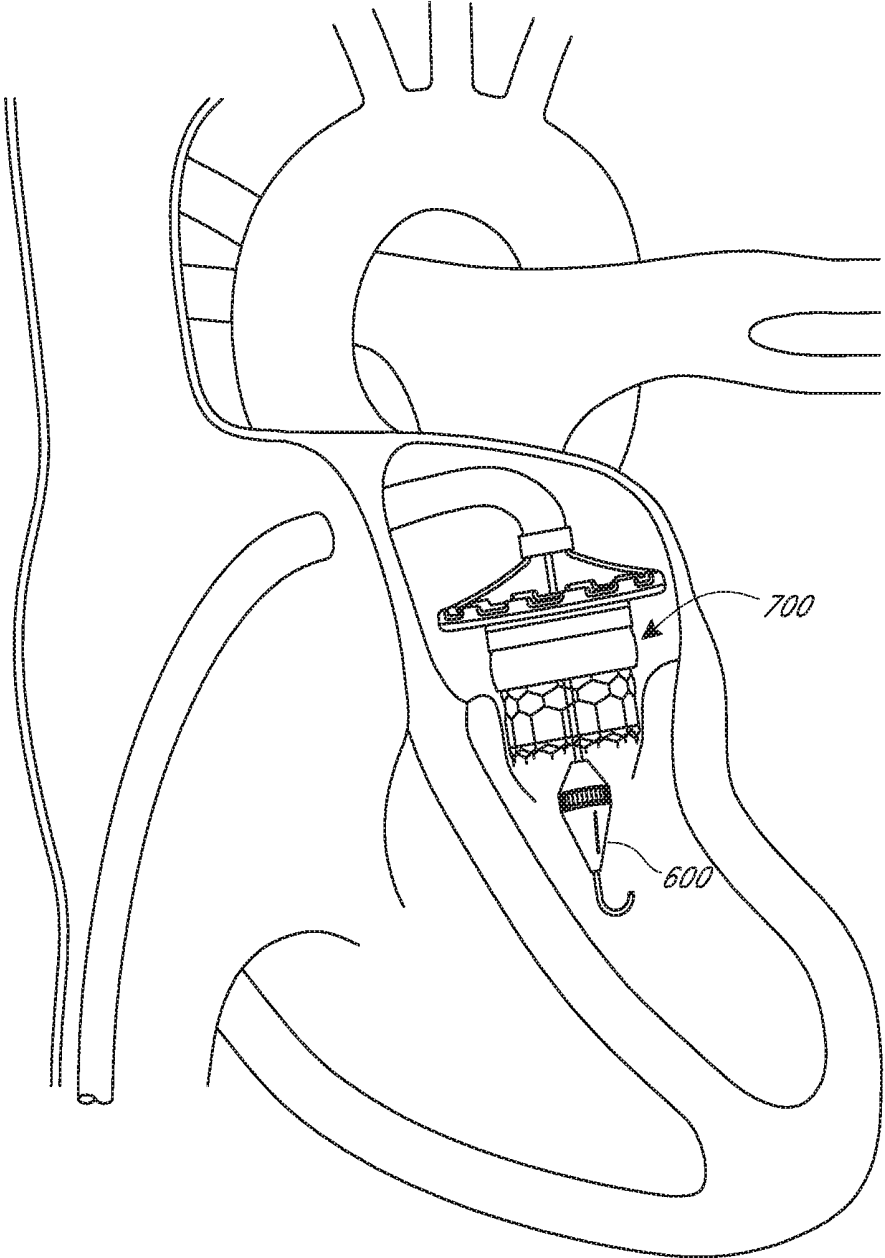

FIG. 5C

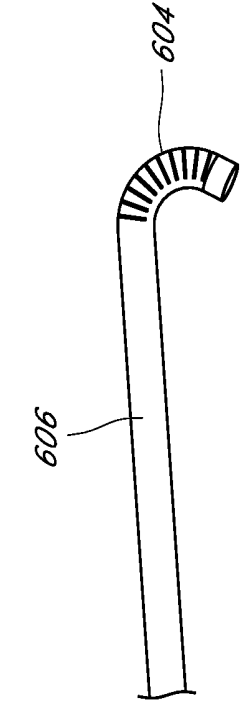

FIG. 6A

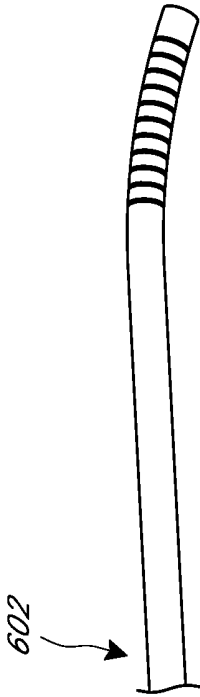

FIG. 6B

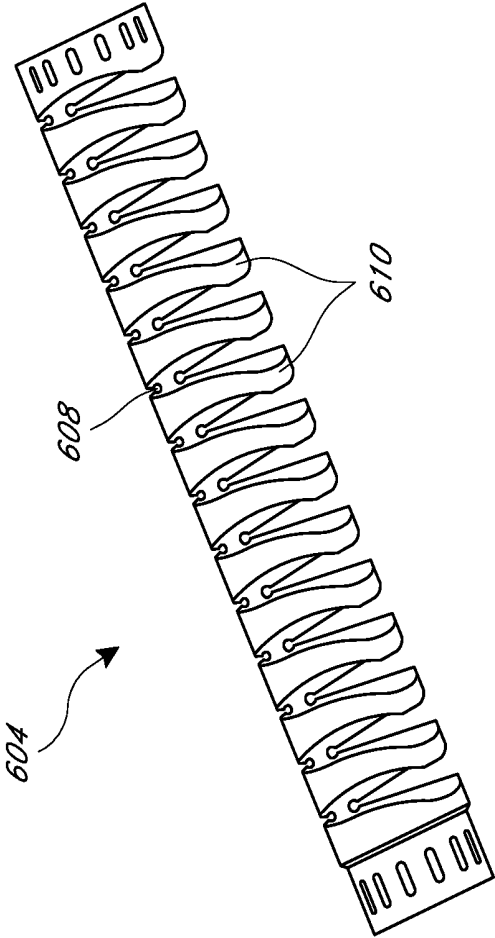

FIG. 7A

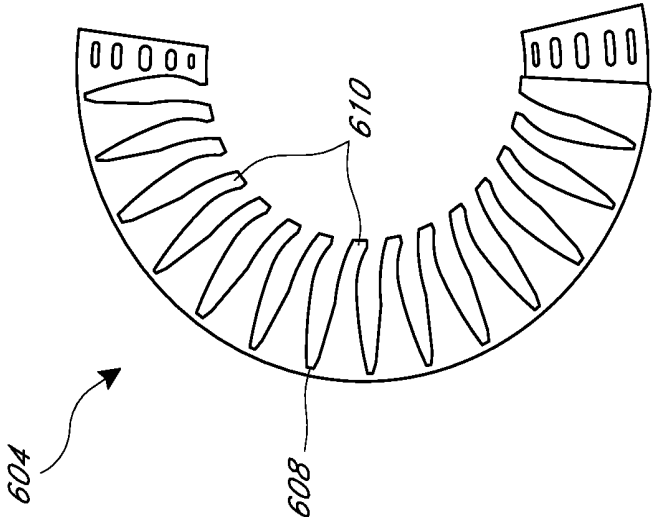

FIG. 7B

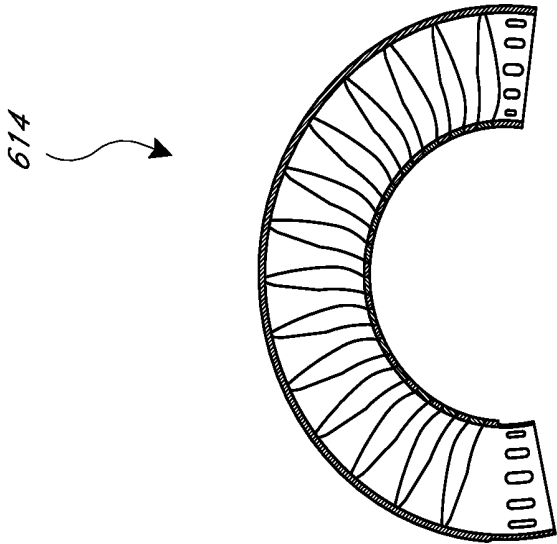

FIG. 8A

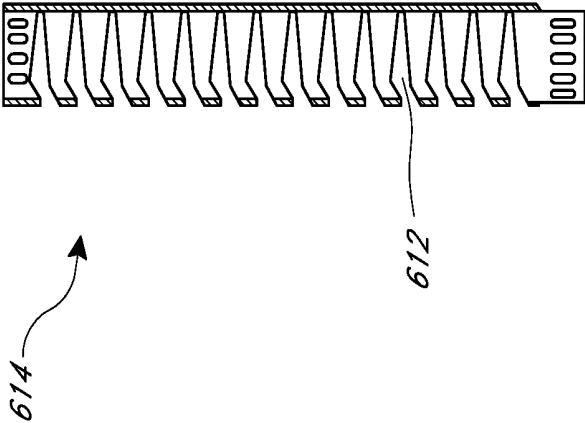

FIG. 8B

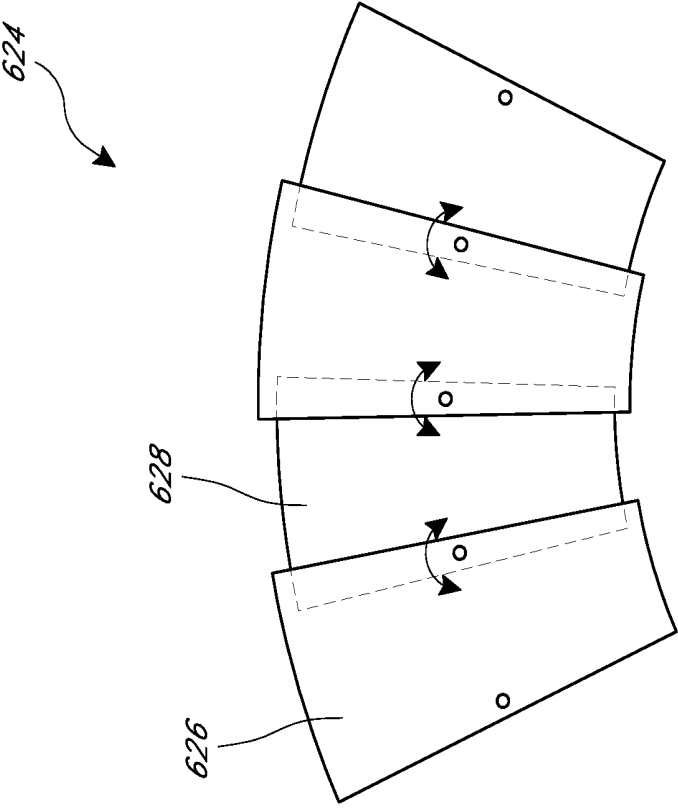

FIG. 9

## METHODS FOR DELIVERY OF HEART VALVE DEVICES USING INTRAVASCULAR ULTRASOUND IMAGING

### INCORPORATION BY REFERENCE TO ANY PRIORITY APPLICATIONS

Any and all applications for which a foreign or domestic priority claim is identified in the Application Data Sheet as filed with the present application are hereby incorporated by reference under 37 CFR 1.57. For example, this application claims the benefit of priority under 35 U.S.C. § 119(e) of U.S. Provisional Application No. 62/234,592 entitled "HEART VALVE DELIVERY SYSTEM WITH INTRAVASCULAR ULTRASOUND IMAGING CAPABILITY" and filed on Sep. 29, 2015, the entire disclosure of which is incorporated herein by reference for all purposes and forms a part of this specification.

### BACKGROUND

#### Field

In general, features related to systems and methods of delivering implantable medical devices are described. For example, delivery and positioning systems and methods for implanting various devices in a heart valve, for example to treat cardiac valve insufficiency, are described.

#### Description of the Related Art

Heart valve incompetency is a serious problem. For example, heart disease can cause the chambers of the heart to expand and weaken. With specific reference to the mitral valve, as a result of aging or disease, the left ventricle dilates and the papillary muscles are displaced. Consequently, the annulus of the mitral heart valve dilates excessively. In this state of dilation, valve leaflets no longer effectively close, or coapt, during systolic contraction. Consequently, regurgitation (i.e. retrograde flow back across the valve that should be closed) of blood occurs during ventricular contraction. Cardiac output is thus decreased.

This condition is typically addressed by the surgical implantation of an annuloplasty ring. A surgeon positions the annuloplasty ring proximate the valve annulus and sutures it in place thereby restoring the valve annulus to approximately its native configuration. The valve leaflets can now function normally again.

This procedure is invasive as it is performed open chest and is also time consuming. In open heart surgery, the patient is put on cardiopulmonary bypass with its associated risks of morbidity and mortality due to stroke, thrombosis, heart attack and extended recovery time.

There is, therefore, a need for less invasive and more efficient solutions to these problems that avoid the aforementioned drawbacks.

### SUMMARY

The embodiments disclosed herein each have several aspects no single one of which is solely responsible for the disclosure's desirable attributes. Without limiting the scope of this disclosure, its more prominent features will now be briefly discussed. After considering this discussion, and particularly after reading the section entitled "Detailed Description," one will understand how the features of the

embodiments described herein provide advantages over existing systems, devices and methods.

The following disclosure describes non-limiting examples of some embodiments. For instance, other embodiments of the disclosed systems and methods may or may not include the features described herein. Moreover, disclosed advantages and benefits can apply only to certain embodiments of the invention and should not be used to limit the disclosure.

Systems and methods of delivering a heart valve implant using ultrasound imaging are described. The implant is intended to be delivered in a minimally invasive percutaneous manner, such as transfemorally, transeptally, or transapically. The implant may instead be implanted surgically, in that it should reduce the duration of the procedure and, more particularly, the duration that the patient is on bypass. Furthermore, it should be recognized that the development can be directed to mitral valve or tricuspid valve procedures.

The development relates to the implant and delivery systems, and associated methods of use of each. The implant is a device capable of extending out to the dilated annulus of a heart valve, engaging the tissue of the heart valve annulus, and gathering or cinching it in to a smaller diameter. The implant includes a tubular frame with moveable struts, where pairs of adjacent struts form apexes. The apexes have collars at least partially surrounded the apex. After engaging heart valve annulus tissue with the implant, the collars can be moved down the apex to decrease the angle between the adjacent struts, causing the tubular frame to contract in width. This pulls the tissue of the heart valve annulus closer together. In some embodiments, the device has a ring-like member formed of a shape memory material that can be expanded, e.g. forcibly expanded, to engage and penetrate the tissue of the heart valve annulus. When the force is removed, the device moves, e.g. pulls, the tissue of the heart valve annulus tissue closer together. The implant thus reconfigures. the valve annulus down to a smaller diameter, reducing and/or eliminating problems associate with the valve, such as regurgitation.

A delivery system and associated methods are also disclosed that comprise a catheter and imaging and positioning features to maneuver the distal end of the catheter and the device into the desired position above and proximate the heart valve annulus. Additionally, the catheter can have modified distal and intermediate sections to facilitate the bending requirements encountered during intravascular or transeptal delivery of the device. Transeptal delivery may be used, for example, with procedures involving the mitral valve. The delivery system can be used with the implant described herein as well as other implantable devices.

Moreover, the development also provides an artificial heart valve with a modified ring-like structure that not only provides for reduction of the heart valve annulus, but also displaces one or more defective heart valve leaflets. The artificial valve may include the various implant devices described herein having the one or more leaflets attached thereto.

In one aspect, a method of anchoring an implant in the heart is described. The method comprises advancing a deployment catheter to a deployment site in a heart, the deployment catheter releasably carrying an implant having at least one tissue anchor, positioning an imaging element in the heart adjacent the implant, visualizing a relationship between the tissue anchor and an anatomical landmark in the heart, and attaching the implant by driving the tissue anchor into tissue in the heart.

In some embodiments, the positioning an imaging element step comprises advancing the imaging element trans-

vascularly along a same access path followed by the deployment catheter. In some embodiments, the positioning an imaging element step comprises advancing the imaging element through a lumen in the deployment catheter.

In some embodiments, the positioning an imaging element step comprises advancing the imaging element transvascularly along an access path that is different from an access path followed by the deployment catheter.

In some embodiments, the positioning an imaging element step comprises directing the imaging element to a predetermined relationship with the deployment catheter using an alignment structure. In some embodiments, the imaging element is carried by an imaging catheter and the positioning step comprises centering the imaging catheter within the implant using the alignment structure. In some

embodiments, the centering step comprises inclining at least one alignment arm with respect to a longitudinal axis of the deployment catheter.

In some embodiments, the visualizing step comprises capturing at least one radial image. In some embodiments, the visualizing step comprises capturing at least one circumferential image. In some embodiments, the visualizing step comprises visualizing a heart valve annulus.

In some embodiments, the visualizing step comprises visualizing a Mitral valve annulus. In some embodiments, the attaching an implant step comprises attaching a Mitral valve annulus reshaping device. In some embodiments, the attaching an implant step comprises attaching a Mitral valve leaflet repair device. In some embodiments, the attaching an implant step comprises attaching a replacement Mitral

valve.

In some embodiments, the attaching step comprises driving at least two anchors into tissue in the heart. In some embodiments, the attaching step comprises driving at least six anchors into tissue in the heart.

In some embodiments, the attaching step comprises rotating the anchor.

In some embodiments, the method further comprises the step of capturing a circumferential image following the attaching step. In some embodiments, the method further comprises the step of releasing the implant from the deployment catheter following the capturing a circumferential image step. In some embodiments, the method further comprises the step of manipulating at least one anchor following the capturing a circumferential image step.

In some embodiments, the visualizing step comprises capturing a field of view that includes at least a portion of the implant and of a Mitral valve leaflet.

In some embodiments, the deployment catheter has a central longitudinal axis and further comprising the step of deflecting the imaging element away from the central longitudinal axis. In some embodiments, the method comprises deflecting the imaging element in the direction of a tissue anchor.

In some embodiments, the method comprises capturing a first image of a first anchor, repositioning the imaging element, and capturing a second image of a second anchor. In some embodiments, the repositioning step comprises rotating the imaging element about an axis. In some embodiments, the repositioning step comprises rotating the imaging element about an axis using a rotational drive mechanism. In some embodiments, the repositioning step comprises manually rotating the imaging element about the axis.

In some embodiments, the imaging element is carried by an imaging catheter, further comprising locking a proximal engagement structure on the imaging catheter to a complementary engagement structure on the deployment catheter.

In another aspect, a method of delivering an implant proximate a cardiac valve annulus is described. The method comprises advancing a distal end of a delivery catheter proximate the cardiac valve annulus, advancing the implant through the distal end of the delivery catheter proximate the cardiac valve annulus, advancing a distal end of an ultrasound catheter proximate the cardiac valve annulus, the distal end of the ultrasound catheter including one or more ultrasonic transducers, capturing an ultrasound image of the implant and the cardiac valve annulus with the one or more ultrasonic transducers, and anchoring the implant to the cardiac valve annulus.

In some embodiments, the method further comprises rotating the distal end of the ultrasound catheter proximate the cardiac valve annulus to a plurality of rotational positions; and capturing a series of ultrasound images of the implant and the cardiac valve annulus with the one or more ultrasonic transducers at the plurality of rotational positions.

In some embodiments, the one or more ultrasonic transducers includes a radial ultrasonic transducer, and wherein capturing the series of ultrasound images comprises capturing one or more radial images of the implant and the cardiac valve annulus to properly position anchors of the implant for insertion into the cardiac valve annulus. In some embodiments, the one or more ultrasonic transducers includes a circumferential ultrasonic transducer, and wherein capturing the series of ultrasound images further comprises capturing one or more circumferential images of the implant and the cardiac valve annulus before anchoring the implant to the cardiac valve annulus. In some embodiments, the one or more ultrasonic transducers includes a circumferential ultrasonic transducer, and wherein capturing the series of ultrasound images further comprises capturing one or more circumferential images of the implant and the cardiac valve annulus after anchoring the implant to the cardiac valve annulus.

In some embodiments, the method comprises advancing the distal end of the delivery catheter proximate the cardiac valve annulus via the femoral vein or the iliac vein. In some embodiments, the method comprises advancing the distal end of the ultrasound catheter proximate the cardiac valve annulus through the delivery catheter. In some embodiments, the method comprises advancing the distal end of the ultrasound catheter proximate the cardiac valve annulus separately from the delivery catheter. In some embodiments, the method comprises advancing the distal end of the ultrasound catheter proximate the cardiac valve annulus through the aortic valve.

In some embodiments, the ultrasound catheter comprises a proximal end having a guidewire entry port, a distal end having a guidewire exit port, and a guidewire extending through the entry and exit ports.

In some embodiments, the ultrasound catheter is an intravascular cardiac echography (ICE) catheter.

In some embodiments, the method comprises centering the ultrasound catheter relative to the implant before capturing the ultrasound image and anchoring the implant. In some embodiments, the method comprises the ultrasound catheter is centered relative to the implant by coupling the implant with the ultrasound catheter via a plurality of radial arms of a centering frame that extend from the implant to the ultrasound catheter.

In some embodiments, the implant comprises a series of struts defining a tubular frame and an axis and forming a plurality of upper and lower crowns, a plurality of anchors coupled with the lower crowns of the frame and configured to translate axially relative to the frame to engage cardiac

tissue proximate the cardiac valve annulus, and a plurality of collars at least partially surrounding the upper crowns and configured to translate axially relative to the frame to adjust a width of the implant. In some embodiments, anchoring the implant to the cardiac valve annulus comprises rotating the plurality of anchors into the cardiac tissue. In some embodiments, the method comprises translating the plurality of collars axially relative to the frame to decrease the width of the implant.

In some embodiments, the implant is a cardiac valve replacement and comprises a series of struts defining a tubular frame and an axis and forming a plurality of lower crowns, a plurality of anchors coupled with the lower crowns of the frame and configured to translate axially relative to the frame to engage cardiac tissue proximate the cardiac valve annulus, and a plurality of valve leaflets coupled with the frame. In some embodiments, anchoring the implant to the cardiac valve annulus comprises rotating the plurality of anchors into the cardiac tissue. In some embodiments, the implant further comprises a housing coupled with the frame, and wherein the leaflets are coupled with the frame via the housing. In some embodiments, the implant further comprises a plurality of upper crowns defined by the series of struts, and a plurality of collars at least partially surrounding the upper crowns and configured to translate axially relative to the frame to adjust a width of the implant. In some embodiments, the implant further comprises an atrial flange.

In some embodiments, the cardiac valve annulus is a mitral valve annulus. In some embodiments, the cardiac valve annulus is a tricuspid valve annulus.

#### BRIEF DESCRIPTION OF THE DRAWINGS

The foregoing and other features of the present disclosure will become more fully apparent from the following description and appended claims, taken in conjunction with the accompanying drawings. Understanding that these drawings depict only several embodiments in accordance with the disclosure and are not to be considered limiting of its scope, the disclosure will be described with additional specificity and detail through use of the accompanying drawings. In the following detailed description, reference is made to the accompanying drawings, which form a part hereof. In the drawings, similar symbols typically identify similar components, unless context dictates otherwise. The illustrative embodiments described in the detailed description, drawings, and claims are not meant to be limiting. Other embodiments may be utilized, and other changes may be made, without departing from the spirit or scope of the subject matter presented here. It will be readily understood that the aspects of the present disclosure, as generally described herein, and illustrated in the drawing, can be arranged, substituted, combined, and designed in a wide variety of different configurations, all of which are explicitly contemplated and make part of this disclosure.

FIGS. 1A through 1E are perspective views of various embodiments of delivery catheters having positioning and imaging capabilities and delivering various embodiments of heart valve implants for resizing the native valve annulus.

FIG. 2 is a side view of an embodiment of a modified intravascular cardiac echography (ICE) catheter for delivering, e.g. aligning and positioning, an implant and having a guidewire entering and exiting the catheter.

FIGS. 3A-3D are perspective views of another embodiment of an ICE catheter and delivery system for delivering, e.g. aligning and positioning, an implant and having a

circular array of sensors at the tip of the catheter, e.g. for radial and/or circumferential echo views.

FIGS. 4A through 4E are sequential perspective views of an embodiment of a delivery system with imaging capability showing an embodiment of a method for the delivery, positioning and anchoring of an embodiment of an implant for resizing the native valve annulus.

FIGS. 5A-5C are sequential perspective views of an embodiment of a delivery system with imaging capability showing an embodiment of a method for the delivery, positioning and anchoring of an embodiment of a replacement heart valve implant.

FIGS. 6A and 6B are side views of an embodiment of a steerable catheter shown in straight and flexed states, respectively, that may be used in the various systems and methods described herein.

FIGS. 7A and 7B are side views of an embodiment of a distal section of a steerable catheter having a spine that may be used in the various systems and methods described herein.

FIGS. 8A and 8B are side views of another embodiment of a distal section of a steerable catheter having a thin film that may be used in the various systems and methods described herein.

FIG. 9 is a side view of another embodiment of a distal section of a steerable catheter having nesting elements that may be used in the various systems and methods described herein.

#### DETAILED DESCRIPTION

The following detailed description is directed to certain specific embodiments of the development. In this description, reference is made to the drawings wherein like parts or steps may be designated with like numerals throughout for clarity. Reference in this specification to “one embodiment,” “an embodiment,” or “in some embodiments” means that a particular feature, structure, or characteristic described in connection with the embodiment is included in at least one embodiment of the invention. The appearances of the phrases “one embodiment,” “an embodiment,” or “in some embodiments” in various places in the specification are not necessarily all referring to the same embodiment, nor are separate or alternative embodiments necessarily mutually exclusive of other embodiments. Moreover, various features are described which may be exhibited by some embodiments and not by others. Similarly, various requirements are described which may be requirements for some embodiments but may not be requirements for other embodiments.

Various heart valve implants may be delivered proximate to, above and/or within, the cardiac valve annulus. Unless otherwise stated, “valve” as used herein may refer to either the tricuspid or mitral valve of the heart. The implant may be subsequently implanted in the annular cardiac tissue just above the plane of the valve orifice. In some embodiments, the implant may be a heart valve replacement including valve leaflets, which can be implanted in annular cardiac tissue and extend into the valve annulus.

Particular features for various embodiments of an implant, of a delivery system, and of related systems and methods of use of the delivery system (either together or separately), are described herein. The implant, delivery system, and related systems and methods of use may have the same or similar features and/or functionalities as other implants, delivery systems, and related systems and methods of use as described, for example, in U.S. patent application Ser. No. 14/861,877 entitled “ADJUSTABLE ENDOLU-

MENAL IMPLANT FOR RESHAPING MITRAL VALVE ANNULUS and filed on Sep. 22, 2015, and as described, for example, in U.S. Provisional Application No. 62/234,592 entitled "HEART VALVE DELIVERY SYSTEM WITH INTRAVASCULAR ULTRASOUND IMAGING CAPABILITY" and filed on Sep. 29, 2015, the entire disclosure of each of which is incorporated herein by reference for all purposes and forms a part of this specification. Thus, the description of particular features and functionalities herein is not meant to exclude other features and functionalities, such as those described in the references incorporated herein by reference or others within the scope of the development.

FIGS. 1A and 1B are perspective views of an embodiment of a distal end of a delivery catheter 40 that may be used to deliver various implants. The delivery catheter 40 has various positioning and imaging capabilities. The distal end of the delivery catheter 40 is maneuvered into position above the heart valve annulus. An implant 1A shown being delivered in FIGS. 1A-1B is for resizing the heart valve annulus. It is understood that a variety of different implants may be delivered with the delivery system and methods described herein. As shown, this particular implant includes a frame 250. The frame 250 has anchors 20 attached to a lower or distal portion of the frame 250 and extending distally therefrom. The frame 250 has an upper or proximal portion with collars 252 extending over upper crowns 251 of the frame 250. Only some of the collars 252, upper crowns 251 and anchors 20 are labelled for clarity. The collars 252 may be moved, e.g. distally, along the frame 250 by driver tubes 260 to resize the frame 250.

The frame 250, driver tubes 260, and an intravascular cardiac echography (or "ICE") catheter 270 may be extended from the distal end of the delivery catheter 40. The drive tubes 260 are shown engaging corresponding upper crowns 252 of the frame 250. A centering frame 280 maintains concentric positioning of the ICE catheter 270 relative to the frame 250 during deployment, alignment and positioning of the frame 250 above and proximate to the target heart valve annulus tissue. The centering frame 280 maintains a generally centered position of the catheter 270 relative to the frame 250. By centering the ICE catheter within the frame 250, the operator need only rotate the ICE catheter 270 to view each anchor 20 and placement of the anchors 20. Further, the ICE catheter 270 could be used to view various other individual features of the implant 1A, such as the collars 252, for instance to view the extent to which each collar 252 is advanced down and over upper crowns 251 of the frame 250, to more precisely adjust the size of the frame 250. The ICE catheter 270 could also provide significant benefit to an embodiment where a singular cinching mechanism or driver tube needs to be landed on each crown 251 of the frame 250 to adjust the sizing of the frame 250. An indexing feature (not shown) may also be provided on the ICE catheter 270, for example, such that actuation of the indexing feature by the operator causes the ICE catheter 270 to automatically move, or rotate, to the next anchor 20 position.

FIGS. 1C and 1D are perspective views of an embodiment of an implant 1B being delivered and implanted by the delivery catheter 40. The implant 1B may be analogous to the implant 1A. By "analogous" it is meant the two features may have the same or similar features and/or functionalities. As shown in FIGS. 1C and 1D, the implant 1B includes a frame 10 with struts 12 forming upper apexes or crowns 14 and lower apexes or crowns 16. The lower crowns 16 have openings 18, such as holes, aligned to receive the anchors 20 there through. For clarity, only some of the upper crowns 14,

lower crowns 16, struts 12 and anchors 20 are labelled in FIGS. 1C and 1D. The anchors 20 may be rotated to move distally through the openings 18. The implant 1B is intended to be delivered proximate to and above a cardiac valve (tricuspid, mitral) annulus, and subsequently implanted in the annular cardiac tissue just above the plane of the valve orifice.

Driver tubes 22, having proximal portions 22' extending out of the delivery catheter 40, are provided for rotationally engaging the anchors 20. Manipulation, for example rotation, of the driver tubes 22 by the operator causes the anchors 20 to advance towards, engage with and penetrate cardiac tissue to secure frame 10 into the annulus approximate and above the valve. The anchors 20 may be advanced individually one at a time, some advanced together, or all advanced together. In some embodiments, the driver tube 22 may rotate relative to the proximal portion 22'. In some embodiments, the driver tube 22 and proximal portion 22' are part of the same, continuous driver tube and/or the entire tube 22 and 22' may rotate together.

An embodiment of an ultrasound catheter 30, such as the Acuson IPX8 AcuNav catheter, is shown contained within and advanced down a central lumen of the delivery catheter 40. The ultrasound catheter 30 may be analogous to the ICE catheter 270. In some embodiments, by rotating the ultrasound catheter 30 around the inside of the valve annulus, the relative position of the frame 10, and of any valve leaflets, will be seen for accurate positioning of the anchors 20 around and above the valve annulus.

In some embodiments, the ultrasound catheter 30 is contained within and advanced down an offset, non-central lumen of the delivery catheter 40. In this manner, the ultrasound catheter 30 would not interfere with the frame 10, its attachments or other features, and the driver components. In some embodiments, the ultrasound catheter 30 may be located and steered to the side of the annulus to image, allowing for less rotation to more quickly view the anchor points of the frame 10. An offset lumen could exit more proximally with regard to the distal end of the delivery catheter 40. This more proximal exit would reduce the overall profile or diameter of the distal end of the delivery catheter 40. In addition, this more proximal exit port would enable a view of the valve annulus from above. The offset lumen could also be compressible allowing for an even smaller profile until the ultrasound catheter 40 is advanced through the offset lumen.

While the ultrasound catheter 30 is shown integrated into the same delivery system as the delivery catheter 40, in some embodiments the ultrasound catheter 30 could otherwise be introduced secondarily through another entry site, such as through the aortic valve, and placed near or inside the implant for imaging and placement of the anchors 20.

FIG. 1E is a perspective view of an embodiment of a centering frame 32 coupled to the ultrasound catheter 30 and to an implant 1C. The implant 1C may be analogous the implants 1A and 1B. The centering frame 32 has centering arms 34 connected to a centering hub 36 that is mounted on the ultrasound catheter 30. As the distal end of the delivery catheter 40 is maneuvered into position above the heart valve annulus, the centering frame 32 maintains concentric positioning of the ultrasound catheter 30 relative to the frame 10 during deployment, alignment and positioning of the frame 10 above and proximate to the target heart valve annulus tissue. The centering aspect is desirable, for example, because if the ultrasound catheter 30 remains centered within the frame 10, the operator such as a surgeon or technician need only rotate the ultrasound catheter 30 to

view each anchor **20** and placement the of each anchor **20**. There may also be an indexing feature (not shown) on the ultrasound catheter **30** such that actuation of the indexing feature by the operator causes the ultrasound catheter **30** to automatically move, or rotate, to the next anchor position. The centering frame **32** maybe used with delivery of the various implants described herein, such as the annulus resizing implants and/or the heart valve replacement implants.

FIG. **2** is a side view of an embodiment of the ICE catheter **270**. The ICE catheter **270** as shown includes a guidewire entry port **292** and a guidewire exit port **294** which together accept the guidewire **296**. This embodiment allows the ICE catheter **270** to be delivered separately from the frame **10** thereby reducing the overall diameter of the delivery catheter **40** (e.g. as shown in FIGS. **1A** and **1B**). An ICE handle may be located at a proximal end of the catheter **270**. An ICE array may be located at the distal end of the catheter **270**.

In some embodiments, a separately delivered ultrasound catheter **270** could be functionally linked to the distal end of the delivery catheter **40** and to the inside of the frame **10**. The delivery catheter **40** could have mechanical docking and radiopaque features to aid in delivery and stability of the ultrasound catheter **270** relative to the delivery catheter **40**.

FIGS. **3A**, **3B**, **3C** and **3D** depict an embodiment of an ICE catheter **300** that may be used with the various implant and delivery devices, systems and methods described herein. The ICE catheter **300** has radial ultrasonic transducers **302**, circumferential ultrasonic transducers **304** and guidewire **306** passing centrally therethrough. In some embodiments, there may be one or more radial ultrasonic transducer and/or one or more circumferential ultrasonic transducers. A guidewire lumen **303** extends out from a delivery catheter **240**. The delivery catheter **240** may be analogous to the delivery catheter **40**. The ICE catheter **300** extends out through the guidewire lumen **303**. FIGS. **3B** and **3C** show an implant **1** deployed with the ICE catheter **300** tip. The implant **1** may be analogous to the implants **1A**, **1B** or **1C**. FIG. **3C** further shows the relationship of the ICE catheter **300** to the delivery catheter **240** while it is taking a radial echo view to properly position the anchor **20** for insertion into heart valve annulus tissue. FIG. **3D** shows the ICE catheter **300** capturing a circumferential echo image for properly positioning the frame **10** in a plane above the heart valve and its leaflets. The features shown and described in FIGS. **3A-3D** may be used to deliver various other implants, such as other resizing devices or heart valve replacement valves.

In some embodiments, software or electronic controls can be effective to cycle through the radial cross sectional images around the valve annulus perimeter, relieving the need to physically move, via rotation, translation or deflection, the ICE catheter **300**. A larger circumferential transducer array could also be placed distal of the annulus to not interfere with space limitations of the delivery catheter **240**, further decreasing the profile of the delivery catheter **240**. In another embodiment, the transducers of the ICE catheter **300** could generate a three dimensional image of the annulus of frame **10**. The user could then more readily see the relative alignment of the annulus, valve leaflets and the implant **1**.

The implant **1** or other implants may be delivered, positioned and anchored to reshape the valve annulus or replace the entire valve. Particular embodiments of delivery methods are described in detail herein with reference to the figures.

Generally, the method includes advancing a deployment catheter, such as the delivery catheters described herein, to

a deployment site in a heart, with the deployment catheter releasably carrying the implant, such as the implant **1** or other implants including heart valve replacements having valve leaflets. The implant has at least one tissue anchor, such as the anchors described herein. An imaging element, such as the ICE or ultrasound catheters described herein, is positioned in the heart adjacent the implant. A relationship is visualized between the tissue anchor and an anatomical landmark in the heart, and the implant is attached by driving the tissue anchor into tissue in the heart.

In some embodiments, the method generally includes advancing a distal end of a delivery catheter, such as the delivery catheters described herein, proximate the cardiac valve annulus in the heart. The implant, such as the implant **1** or other implants including heart valve replacements having valve leaflets or Mitral valve leaflet repair devices, is advanced through the distal end of the delivery catheter proximate the cardiac valve annulus. A distal end of an ultrasound catheter, such as the ICE or other ultrasound catheters described herein, is advanced proximate the cardiac valve annulus. The distal end of the ultrasound catheter includes one or more ultrasonic transducers. An ultrasound image is captured, the image being of the implant and the cardiac valve annulus, and captured with the one or more ultrasonic transducers, and the implant is anchored to the cardiac valve annulus. The images may be used to verify the position of, and/or re-position, the anchors before driving the anchors into the cardiac tissue.

These are general descriptions of some embodiments of methods that may be performed. Particular embodiments of delivering an annulus re-sizing implant are described with respect to FIGS. **4A-4E**, and of delivering a heart valve replacement implant are described with respect to FIGS. **5A-5C**.

As shown in FIG. **4A**, the implant **1** may be inserted into the heart using a delivery system **401**. The implant **1** may be inserted using the delivery system **401** via access to the vasculature of the leg, in particular the femoral vein or the iliac vein. The system **401** may include the various implants, catheters and other features described herein, for example the implant **1**, a deployment catheter such as the delivery catheter **240**, an imaging element such as the ICE catheter **300** and/or transducers thereon, the guidewire **306**, etc. The system **401** may include any of the implants described herein, for example implants including valve annulus reshaping devices or valve replacements that include valve leaflets. The system **401** is then advanced across the septum separating the upper chambers of the heart.

As shown in FIG. **4B**, the imaging element such as the ICE catheter **300** is advanced to a position above the heart valve annulus, for example, the mitral valve annulus. FIG. **4C** shows the implant **1** expelled, i.e. deployed, from the distal end of the delivery catheter **240** above and proximate to the mitral valve annulus. In some embodiments, the implant **1** may be deployed before the ICE catheter **300**.

The ICE catheter **300** may be positioned by advancing the ICE catheter **300** transvascularily along a same access path followed by the delivery catheter **240**. The ICE catheter **300** may be positioned by advancing the ICE catheter **300** through a lumen in the delivery catheter **240**. In some embodiments, the ICE catheter **300** may be positioned by advancing the ICE catheter **300** transvascularily along a different path than that followed by the delivery catheter **240**. As further shown in FIG. **4B**, the guidewire **306** may extend through the annulus and into the left ventricle.

In some embodiments, the delivery system **401** may be used to treat the tricuspid valve. For example, the delivery

system **401** may be inserted for access through the jugular vein whereby the system **401** is then advanced down the superior vena cava and into the right atrium proximate and above the tricuspid valve annulus.

In some embodiments, the ICE catheter **300** is positioned by directing the ICE catheter **300** to a predetermined relationship with the deployment catheter **240** using an alignment structure, such as the centering frame **32** or **280**. In some embodiments, the ICE catheter **300** is centered within the implant **1** using the alignment structure. In some embodiments, an alignment arm, such as the radial centering arm **34**, of the alignment structure is inclined with respect to a longitudinal axis of the deployment catheter **240**.

In some embodiments, the deployment catheter has a central longitudinal axis and the ICE catheter **300**, for example the distal end and/or a transducer thereon, is deflected away from the central longitudinal axis. In some embodiments, the method comprises deflecting the ICE catheter **300** in the direction of one or more of the tissue anchors **20**. In some embodiments, a first image of a first anchor **20** is captured, the ICE catheter **300** or portion thereof is then repositioned, and then a second image of a second anchor **20** is captured. In some embodiments, the repositioning step comprises rotating the ICE catheter **300** about an axis. In some embodiments, the repositioning step comprises rotating the ICE catheter **300** about an axis using a rotational drive mechanism. In some embodiments, the repositioning step comprises manually rotating the ICE catheter **300** about the axis. In some embodiments, the ICE catheter **300** carries the imaging element such as a transducer, and the imaging element is rotated, deflected, etc. as described. In some embodiments, a proximal engagement structure on the ICE catheter **300** is locked to a complementary engagement structure on the delivery catheter **240**.

As shown in FIG. 4D, at least one radial image is taken with the ICE catheter **300**. A series of radial images may be taken. The radial images are used to properly position the anchors **20** for insertion into the mitral valve annulus tissue. The anchors **20** may be confirmed to be in the proper position, orientation, etc. and driven into the cardiac tissue, for example by rotating the anchors **20**. In some embodiments, the implant is attached by driving at least two anchors into tissue in the heart. In some embodiments, the implant is attached by driving at least six anchors into tissue in the heart. In some embodiments, the implant is attached by driving at least eight anchors into tissue in the heart. Other amounts of the anchors may be used as well.

In some embodiments, the distal end of the ICE catheter **300** is rotated proximate the cardiac valve annulus to a plurality of rotational positions, and a series of ultrasound images are captured of the implant **1** and the cardiac valve annulus at the plurality of rotational positions.

As shown in FIG. 4E, a circumferential image is captured. In some embodiments, multiple circumferential images may be taken. The circumferential image is taken after the one or more radial images. In some embodiments, the circumferential image may be taken prior to the radial imaging. The circumferential image may be used to confirm that all anchors **20** are appropriately placed and anchored in the mitral valve annulus tissue above the mitral valve leaflets. If one or more anchors **20** are not positioned or anchored properly, they can be manipulated, for example rotationally retracted, repositioned and re-anchored, prior to removal of the driver tubes. In addition, a circumferential image can be taken prior to anchoring to confirm location of the lower crowns **16** of the frame **10** of the implant **1**. The radial and/or circumferential images may be used to visualize various

anatomical features of the heart, such as the heart valve annulus, the heart valve, valve leaflets, the Mitral valve, the Tricuspid valve, and/or other features. In addition or alternatively, the radial and/or circumferential images may be used to visualize various features of the delivery system **401**, such as the implant **1**, the anchors **20**, etc. The implant **1** may be released from the delivery catheter **240** following capturing the circumferential image.

FIGS. 5A-5C are sequential perspective views of an embodiment of a delivery system with imaging capability showing an embodiment of a method for the delivery, positioning and anchoring of an artificial or replacement heart valve **700**. The methods described with respect to FIGS. 5A-5C of delivering the replacement heart valve **700** may incorporate any of the features of the delivery method described with respect to FIGS. 4A-4E regarding delivery of the implant **1**.

FIGS. 5A-5C show an ultrasound catheter **600** having a guidewire **660** used to guide or assist in the delivery and positioning of the replacement heart valve **700**. The replacement heart valve **700** may be a variety of suitable heart Mitral or Tricuspid heart valve replacements, such as the Edwards Lifesciences Fortis or the Medtronic Twelve transcatheter mitral valve. In some embodiments, the replacement heart valve **700** with valve leaflets may be delivered with the various ultrasound systems described herein. The delivery system is inserted via access to the vasculature of the leg, in particular the femoral vein or the iliac vein. The system is then advanced across the atrial-septal wall separating the upper chambers of the heart, as shown in FIG. 5A. The ultrasound catheter **600** is advanced to a position above the heart valve annulus, or more specifically, the mitral valve annulus, as shown in FIG. 5B. FIG. 5C shows the valve **700** expelled from the delivery catheter across the mitral valve, excluding and replacing the function of the native valve. The method shown in FIGS. 5A-5C may incorporate other features described herein, such as those described with respect to FIGS. 4A-4E, for example the various imaging features, various other implants, other access points to the heart, etc.

Relatively large diameter catheter shafts are described herein that may be used to deliver the ring-like implants, such as the implant **1**, or valve replacements, such as the valve **700**, described herein. These large diameter catheter shafts may include features that mitigate or eliminate the tendency to kink, wrinkle or tear when attempting a sharp bend radius. FIGS. 6A through 9 show various embodiments of sections of steerable catheters that improve the catheter's ability to maneuver tight bends to a position above and proximate and/or into the mitral valve annulus or tricuspid valve annulus.

FIGS. 6A and 6B show a steerable catheter **602** in somewhat straight and flexed states, respectively. The steerable catheter **602** may be used in the various delivery systems and methods described herein. The steerable catheter **602** has a distal section **604** and intermediate section **606**. The intermediate section **606** may take the form of a shaft section reinforced with a braid or slotted tubing.

FIGS. 7A and 7B depict an embodiment of the distal section **604** that may be used with the steerable catheter **602**, shown in straight and flexed states, respectively. The distal section **604** has a single spine **608** running along its outer curve, and a series of support ribs **610** formed or cut into the inner curve. The distal section **604** may be formed of a flexible metal tube, such as nitinol. The distal section **604** may incorporate pull wires for control of the delivery system. Alternatively, the pull wire may be looped around

the distal section's distal tip and back toward the proximal part of the catheter 602. The support ribs 610, with voids therebetween, allow the distal section 604 to achieve a tight bend radius. This flexed state of the distal section 604 is realized with minimal protrusion of the support ribs 610 into the inner diameter or outer diameter of the distal section 604. Moreover, the spine 608 provides a smooth surface on the outer curve of the distal section 604 minimizing friction or interference with heart tissue during delivery and positioning of the catheter and implant.

FIGS. 8A and 8B illustrate another embodiment of a distal section 614 that may be used with the steerable catheter 602. Here, the distal section 614 may be a flexible metal tube that is wrapped or encased in a thin film 612 or polymeric material such as Teflon, pTfe, nylon or other thin material. This thin film 612 encapsulation does not restrict the flexibility of the distal section 614 but does provide for smoother delivery and transition into and out of a guide catheter. The thin film 612 may be stretchable or designed to fold in on itself, somewhat similar to an accordion, when flexed as shown in FIG. 8B.

FIG. 9 shows another embodiment of a distal section 624 that may be used with the steerable catheter 602. Here, distal section 624 comprises a series of larger elements 626 and smaller elements 628. The smaller elements 628 nest within the larger elements 626. All elements may slide over one another. When the distal section 624 is in a straight state, the metal elements are most overlapped. As the distal section 624 is actuated towards the flexed state, as shown for example in FIG. 9, there may be progressively less overlap of the elements particularly on the outer curve of the distal section 624.

The embodiments of the distal and intermediate sections of the catheter 602 are intended for use in the delivery and implant of both the ring-like embodiments and the replacement valve embodiments described herein. In treating the mitral valve, for example, once the catheter is passed through the septum separating the right and left atria, it is guided slightly upwardly towards the upper reaches of the left atrial chamber. It is then bent significantly in a direction downward towards the mitral annulus, aligning the distal end and the implant with the mitral annulus. The devices, systems and methods described herein allow such bending to occur without kinking or wrinkling which would otherwise impede delivery of the implant.

Various modifications to the implementations described in this disclosure will be readily apparent to those skilled in the art, and the generic principles defined herein can be applied to other implementations without departing from the spirit or scope of this disclosure. Thus, the disclosure is not intended to be limited to the implementations shown herein, but is to be accorded the widest scope consistent with the claims, the principles and the novel features disclosed herein. The word "example" is used exclusively herein to mean "serving as an example, instance, or illustration." Any implementation described herein as "example" is not necessarily to be construed as preferred or advantageous over other implementations, unless otherwise stated.

Certain features that are described in this specification in the context of separate implementations also can be implemented in combination in a single implementation. Conversely, various features that are described in the context of a single implementation also can be implemented in multiple implementations separately or in any suitable sub-combination. Moreover, although features can be described above as acting in certain combinations and even initially claimed as such, one or more features from a claimed combination can

in some cases be excised from the combination, and the claimed combination can be directed to a sub-combination or variation of a sub-combination.

Similarly, while operations are depicted in the drawings in a particular order, this should not be understood as requiring that such operations be performed in the particular order shown or in sequential order, or that all illustrated operations be performed, to achieve desirable results. Additionally, other implementations are within the scope of the following claims. In some cases, the actions recited in the claims can be performed in a different order and still achieve desirable results.

It will be understood by those within the art that, in general, terms used herein are generally intended as "open" terms (e.g., the term "including" should be interpreted as "including but not limited to," the term "having" should be interpreted as "having at least," the term "includes" should be interpreted as "includes but is not limited to," etc.). It will be further understood by those within the art that if a specific number of an introduced claim recitation is intended, such an intent will be explicitly recited in the claim, and in the absence of such recitation no such intent is present. For example, as an aid to understanding, the following appended claims may contain usage of the introductory phrases "at least one" and "one or more" to introduce claim recitations. However, the use of such phrases should not be construed to imply that the introduction of a claim recitation by the indefinite articles "a" or "an" limits any particular claim containing such introduced claim recitation to embodiments containing only one such recitation, even when the same claim includes the introductory phrases "one or more" or "at least one" and indefinite articles such as "a" or "an" (e.g., "a" and/or "an" should typically be interpreted to mean "at least one" or "one or more"); the same holds true for the use of definite articles used to introduce claim recitations. In addition, even if a specific number of an introduced claim recitation is explicitly recited, those skilled in the art will recognize that such recitation should typically be interpreted to mean at least the recited number (e.g., the bare recitation of "two recitations," without other modifiers, typically means at least two recitations, or two or more recitations). Furthermore, in those instances where a convention analogous to "at least one of A, B, and C, etc." is used, in general such a construction is intended in the sense one having skill in the art would understand the convention (e.g., "a system having at least one of A, B, and C" would include but not be limited to systems that have A alone, B alone, C alone, A and B together, A and C together, B and C together, and/or A, B, and C together, etc.). In those instances where a convention analogous to "at least one of A, B, or C, etc." is used, in general such a construction is intended in the sense one having skill in the art would understand the convention (e.g., "a system having at least one of A, B, or C" would include but not be limited to systems that have A alone, B alone, C alone, A and B together, A and C together, B and C together, and/or A, B, and C together, etc.). It will be further understood by those within the art that virtually any disjunctive word and/or phrase presenting two or more alternative terms, whether in the description, claims, or drawings, should be understood to contemplate the possibilities of including one of the terms, either of the terms, or both terms. For example, the phrase "A or B" will be understood to include the possibilities of "A" or "B" or "A and B."

What is claimed is:

1. A method of anchoring an implant having a replacement mitral valve in the heart, comprising:

15

advancing a deployment catheter to a deployment site in a heart, the deployment catheter releasably carrying the implant having at least one tissue anchor;  
 positioning an imaging element in the heart adjacent the implant;  
 visualizing a relationship between the tissue anchor and a mitral valve annulus; and  
 attaching the replacement mitral valve by driving the tissue anchor into tissue in the heart wherein the imaging element is carried by an imaging catheter, and the positioning step comprises centering the imaging catheter within the implant.

2. The method of claim 1, wherein the positioning an imaging element step comprises advancing the imaging element transvascularily along a same access path followed by the deployment catheter.

3. The method of claim 1, wherein the positioning an imaging element step comprises advancing the imaging element transvascularily along an access path that is different from an access path followed by the deployment catheter.

4. The method of claim 1, wherein the positioning an imaging element step comprises directing the imaging element to a predetermined relationship with the deployment catheter using an alignment structure.

5. The method of claim 4, wherein the positioning step comprises centering the imaging catheter within the implant using the alignment structure.

6. The method of claim 5, wherein the centering step comprises inclining at least one alignment arm with respect to a longitudinal axis of the deployment catheter.

7. The method of claim 1, wherein the visualizing step comprises capturing at least one radial image.

8. The method of claim 1, wherein the visualizing step comprises capturing at least one circumferential image.

9. The method of claim 1, wherein the attaching the replacement mitral valve step comprises driving at least two anchors into tissue in the heart.

10. The method of claim 9, further comprising the step of capturing a circumferential image following the attaching step.

11. The method of claim 10, further comprising the step of releasing the implant from the deployment catheter following the capturing a circumferential image step.

12. The method of claim 10, further comprising the step of manipulating at least one anchor following the capturing a circumferential image step.

13. The method of claim 9, comprising capturing a first image of a first anchor, repositioning the imaging element, and capturing a second image of a second anchor.

14. The method of claim 1, wherein the attaching step comprises rotating the anchor.

15. The method of claim 1, wherein the deployment catheter has a central longitudinal axis and further comprising the step of deflecting the imaging element away from the central longitudinal axis.

16. A method of delivering an implant proximate a cardiac valve annulus, the method comprising:  
 advancing a distal end of a delivery catheter proximate the cardiac valve annulus;  
 advancing the implant through the distal end of the delivery catheter proximate the cardiac valve annulus;  
 advancing a distal end of an ultrasound catheter proximate the cardiac valve annulus, the distal end of the ultrasound catheter including one or more ultrasonic transducers;

16

capturing an ultrasound image of the implant and the cardiac valve annulus with the one or more ultrasonic transducers; and  
 anchoring the implant to the cardiac valve annulus,  
 wherein the implant comprises:  
 a series of struts defining a tubular frame and an axis and forming a plurality of upper and lower crowns;  
 a plurality of anchors coupled with the lower crowns of the frame and configured to translate axially relative to the frame to engage cardiac tissue proximate the cardiac valve annulus; and  
 a plurality of collars at least partially surrounding the upper crowns and configured to translate axially relative to the frame to adjust a width of the implant.

17. The method of claim 16, further comprising:  
 rotating the distal end of the ultrasound catheter proximate the cardiac valve annulus to a plurality of rotational positions; and  
 capturing a series of ultrasound images of the implant and the cardiac valve annulus with the one or more ultrasonic transducers at the plurality of rotational positions.

18. The method of claim 16, wherein the one or more ultrasonic transducers includes a radial ultrasonic transducer, and wherein capturing the series of ultrasound images comprises capturing one or more radial images of the implant and the cardiac valve annulus to properly position anchors of the implant for insertion into the cardiac valve annulus.

19. The method of claim 18, wherein the one or more ultrasonic transducers includes a circumferential ultrasonic transducer, and wherein capturing the series of ultrasound images further comprises capturing one or more circumferential images of the implant and the cardiac valve annulus.

20. The method of claim 16, comprising advancing the distal end of the ultrasound catheter proximate the cardiac valve annulus separately from the delivery catheter.

21. The method of claim 20, comprising advancing the distal end of the ultrasound catheter proximate the cardiac valve annulus through the aortic valve.

22. The method of claim 20, wherein the ultrasound catheter comprises:  
 a proximal end having a guidewire entry port;  
 a distal end having a guidewire exit port; and  
 a guidewire extending through the entry and exit ports.

23. The method of claim 16, further comprising centering the ultrasound catheter relative to the implant before capturing the ultrasound image and anchoring the implant.

24. A method of delivering an implant proximate a cardiac valve annulus, the method comprising:  
 advancing a distal end of a delivery catheter proximate the cardiac valve annulus;  
 advancing the implant through the distal end of the delivery catheter proximate the cardiac valve annulus;  
 advancing a distal end of an ultrasound catheter proximate the cardiac valve annulus, the distal end of the ultrasound catheter including one or more ultrasonic transducers;  
 capturing an ultrasound image of the implant and the cardiac valve annulus with the one or more ultrasonic transducers; and  
 anchoring the implant to the cardiac valve annulus, wherein the implant is a cardiac valve replacement and comprises:  
 a series of struts defining a tubular frame and an axis and forming a plurality of lower crowns;  
 a plurality of anchors coupled with the lower crowns of the frame and configured to translate axially relative

17

to the frame to engage cardiac tissue proximate the cardiac valve annulus; and a plurality of valve leaflets coupled with the frame.

25. The method of claim 24, further comprising: rotating the distal end of the ultrasound catheter proximate the cardiac valve annulus to a plurality of rotational positions; and

capturing a series of ultrasound images of the implant and the cardiac valve annulus with the one or more ultrasonic transducers at the plurality of rotational positions.

26. The method of claim 24, wherein the one or more ultrasonic transducers includes a radial ultrasonic transducer, and wherein capturing the series of ultrasound images comprises capturing one or more radial images of the implant and the cardiac valve annulus to properly position anchors of the implant for insertion into the cardiac valve annulus.

27. The method of claim 26, wherein the one or more ultrasonic transducers includes a circumferential ultrasonic

18

transducer, and wherein capturing the series of ultrasound images further comprises capturing one or more circumferential images of the implant and the cardiac valve annulus.

28. The method of claim 24, comprising advancing the distal end of the ultrasound catheter proximate the cardiac valve annulus separately from the delivery catheter.

29. The method of claim 28, comprising advancing the distal end of the ultrasound catheter proximate the cardiac valve annulus through the aortic valve.

30. The method of claim 28, wherein the ultrasound catheter comprises:

- a proximal end having a guidewire entry port;
- a distal end having a guidewire exit port; and
- a guidewire extending through the entry and exit ports.

31. The method of claim 24, further comprising centering the ultrasound catheter relative to the implant before capturing the ultrasound image and anchoring the implant.

\* \* \* \* \*

专利名称(译)	使用血管内超声成像输送心脏瓣膜装置的方法		
公开(公告)号	<a href="#">US10335275</a>	公开(公告)日	2019-07-02
申请号	US15/280004	申请日	2016-09-29
[标]申请(专利权)人(译)	米利佩德有限责任公司		
申请(专利权)人(译)	千足虫, INC.		
当前申请(专利权)人(译)	千足虫, INC.		
[标]发明人	LASHINSKI RANDALL KRISTOFFERSEN KRISTIAN RUST MATTHEW GLENN RICHARD LEE MICHAEL MACAULAY PATRICK		
发明人	LASHINSKI, RANDALL KRISTOFFERSEN, KRISTIAN RUST, MATTHEW GLENN, RICHARD LEE, MICHAEL MACAULAY, PATRICK		
IPC分类号	A61F2/24 A61B17/064 A61B8/08 A61B8/12 A61B8/00		
CPC分类号	A61F2/2427 A61B8/085 A61B8/0841 A61B8/0883 A61B8/12 A61B17/064 A61F2/2412 A61F2/2466 A61B8/445 A61B2017/0649 A61B2017/0647		
其他公开文献	US20170086974A1		
外部链接	<a href="#">Espacenet</a>		

摘要(译)

描述了与各种心脏瓣膜植入物的输送相关的方法。可以使用超声成像递送系统递送植入物。超声成像输送系统可用于输送各种不同的装置,包括二尖瓣再成形装置,二尖瓣置换瓣膜等。携带具有组织锚的植入物的展开导管前进到心脏中的展开部位。成像元件定位在植入物附近,并且组织锚和心脏中的解剖学界标之间的关系可视化。然后将组织锚固件驱动到心脏组织中来附接植入物。

